



## Operating Instructions & Parts Manual

Please read and save these instructions. Read carefully before attempting to assemble, install, operate or maintain the product described. Protect yourself and others by observing all safety information. Failure to comply could result in personal injury and/or property damage. Retain instructions for future reference.

# MODULE-AIR AF-36xxVT SERIES AIR CLEANER

(AF-3643VT, AF-3623VT VERTICAL AND AF-3643VT, AF-3623VT HORIZONTAL)

### Description

This 14,000 CFM Air Cleaner was designed for use as ambient air filtration where airborne particles are prevalent. The air cleaner consists of 6 intakes and one exhaust, one motor, one blower, electrical components and a riveted sheet metal housing.

These units are about 750 pounds, and cannot be handled or transported without the help of lifting tools.

It is recommended that you consult a professional electrician prior to installing this product. If this Air Cleaner is to be used in an application that presents a potential fire hazard, a fire protection expert should be consulted.

### Unpacking

The machine should be unpacked carefully. Check if the machine and components are consistent with those indicated in the Parts List. If any doubt arises or if parts appear to be missing, contact your dealer.

MOTOR OPTIONS:				
MODEL NUMBER	VOLTAGE	HP	Hz	AMP DRAW
AF-36xxVT230	230V THREE PHASE	10 HP	60/50	27-25
AF-36xxVT480	480V THREE PHASE	10 HP	60/50	12.5
AF-36xxVT575	575V THREE PHASE	10 HP	60	11.2
BLOWER:				
MODEL NUMBER	TYPE:	CFM:		
(ALL)	FORWARD INCLINE	14000		

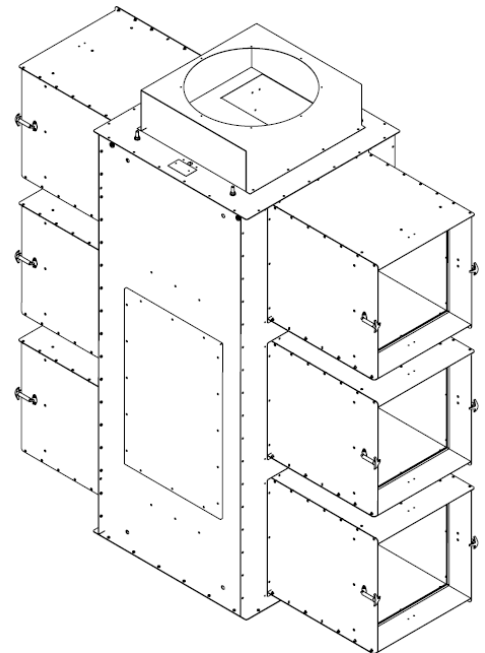

Seen above: AF-3623VT with Transition

**SOUND LEVEL:** 68 Db(A)

APPROXIMATE WIEGHT	
AF-36xxVT	750 lbs

## Operation

Once installed using the above instructions, your AF-36xxVT air cleaner(s) can be operated with the flip of a switch. Because the AF-36xxVT series is designed as an "Air quality Maintenance" system, it is important that the units are turned on in the beginning of the shift and left on until the end of the shift. The reason the units need to remain on is because Air Cleaners train the air current throughout the entire area in order to ensure that all of the air is cycling through the filters. The process of training the air can take a while, but is usually about 30 minutes.

## Maintenance

Follow these precautions when performing maintenance on the motor or blower.

Turn off motor, and LOCK OUT electrical service to the unit.

LOCK OUT even when changing filters.

Change filters regularly to maintain optimum performance. If the performance of your air cleaners appears to be declining, try replacing the filters.

Be sure that replacement filters are always rated for the correct CFM and air flow.

### NOTE FOR INSTALLING BAG FILTERS:

**When installing fiberglass bag filters, MAKE SURE THAT NO FABRIC IS PINCHED BETWEEN THE HEADER AND FILTER FRAME.** Performance will decrease dramatically if bag filters are not properly installed. To ensure no fabric is pinched, place your fingers inside each cell, and gently move each bag cell side to side, freeing any fabric sandwiched between the header and filter frame.

### If the system requires maintenance exceeding filter change, read below...

Take the unit down and place it on a level surface that allows access to the back panel of the Main Housing.

**To access the motor, pulleys and belt:** Remove the door panel by removing (16) ¼-20x1-1/4" bolts with a 3/8 socket.

Symptom	Possible Cause(s)	Corrective Action
Excessive belt noise	1. Belt is loose	1. Remove door panel, loosen nuts that fasten motor, turn adjustment screw until optimum belt tension is achieved
	2. Belt needs to be flipped.	2. Follow step (1) to loosen belt, then remove belt and turn it around. Replace belt, and then reverse step (1) to tighten belt and re-assemble.
	3. Belt is worn out or glazed.	2. Follow step (1) to loosen belt, put new one on, and then reverse step (1) to tighten belt and re-assemble
Air cleaner has poor performance.	<b>1. It's possible that the air cleaner may have been wired backwards upon installation. Air will blow out the exhaust either way, but if wired correctly it should blow at about 58 mph.</b>	<b>1. If the motor is wired to run the wrong direction, disconnect power supply, &amp; switch the necessary wires around to reverse the motors rotation with the voltage you are using.</b>
	<b>2. The bag filter may not be seated properly</b>	<b>2. Reach in each pocket to make sure fabric is not between filter stop and filter frame.</b>
Air is not staying as clear as usual	1. Prefilters may be loaded with debris	1. Turn unit off, lock out power to unit, then replace the prefilter by pushing clips out of the way and then sliding it out and sliding a new one in.
	2. Bag filter(s) may be spent	2. Follow step (1) to remove the prefilter, then if unit is equipped with clips, push them out and away from the bag filter, slide out the old bag filter and slide in new one until clips snap around it.

## Troubleshooting Chart

## General Safety information SAFETY GUIDELINES- DEFINITIONS

This manual contains information that important for you to know and understand. This information relates to protecting YOUR SAFETY and PREVENTING EQUIPMENT PROBLEMS.

### GENERAL SAFETY RULES

#### !WARNING!

This machine was designed for certain applications only. Tanis Technologies strongly recommends that this machine not be modified and/or used for any application other than that for which it was designed. If you have any questions relative to a particular application, DO NOT use the machine until you have first contacted Tanis Technologies and confirmed that the product is suited for your application.

#### !WARNING!

Failure to follow these rules may result in serious personal injury.

#### 1. For your safety, read and understand the instruction manual before operating the unit.

Learn the unit's application and limitations as well as the specific hazards, related to it.

#### 2. Don't use in dangerous environment.

Don't use this unit in damp or wet locations or expose to rain.

#### 3. Disconnect unit before servicing.

4. Check damaged parts before future use of the unit, properly repair or replace any part that is damaged.

### ADDITIONAL SAFETY RULES FOR AIR CLEANERS

1. Install Module-Air AF-36xxVT

series air cleaners according to all electrical and safety codes as well as the National Electrical Code (NEC) National Fire Protection Association (NFPA) and the Occupational Safety and Health Act (OSHA). Only someone who is qualified to do electrical work should wire the units in.

2. These air cleaners are intended to be installed at least **8.2 feet (2.5 meters) above the floor.**

3. Specific duct design and dust collector configurations are required under standards set forth by the National Fire Protection Association (NFPA). These are applicable when collecting potentially reactive metal dusts (like aluminum, magnesium and other materials). NFPA also has standards that cover other dusts like grain and plastics, ect. For guidelines on determining which precautions should be taken, please refer to NFPA 497. There may be other specifications that apply for your particular application, so please consult current NFPA standards that may be acquired at:

NFPA  
1 Batterymarch Park  
Quincy, MA 02269  
1-800-344-3555

This information may contain safeguards that are required for the installation, operation and service of AF-24xx series products.

#### !WARNING!

4. Avoid mixing combustible materials like (but not limited to) the following: buffing lint, paper/wood dust, aluminum or magnesium with dust generated from the grinding of ferrous materials. This creates a potential

for fires due to the mixing of sparks and combustible materials.

5. A machine operator should NEVER be allowed to put lit cigarettes or any burning object into this or any dust control system.

6. If there is a chance for heated and/or flammable materials to enter the unit, installation of the unit should be evaluated to determine if a fire protection/exhaustion systems should be installed. Federal, State or local codes, as required by organizations such as NFPA and Factory Mutual Insurance or your insurance carrier may require such a system. **Module-Air can offer basic guidelines for such an installation: however, final installation design is the responsibility of the purchaser.**

7. Securely anchor unit to a permanent or fixed supporting structure, be sure the structure is rated to hold the weight of the unit.

8. Support this unit or clamp it to the work surface when using it in a portable application to eliminate potential injury or damage to the unit

9. Ensure that the intake and exhaust areas are clear prior to starting the unit. Clogged intakes or exhaust can cause explosion and/or fire.

10. Keep arms and fingers away from fan. Avoid all exposure to rotating parts to prevent injury.

11. Do not attempt to remove/replace filters while unit is running. Fan blades can cause severe cuts. Be sure the unit is disconnected from power source

12. Maintain the unit in top condition. Clogged filters can increase potential for fire or explosion. Follow instructions for changing filters.

13. Turn the unit “off” and disconnect power source before installing or removing accessories, before adjusting or changing set-ups or when making repairs. An accidental start up can cause serious injury.

14. Explosion relief vents are required for some applications. Consult with an insurance underwriter or an NFPA manual to determine proper vent size and ratio. **Module-Air LLC DOES NOT CONTAIN EXPLOSION RELIEF VENTS** as shipped from the factory and must be field installed per NFPA standards.

15. The AF-36xxVT series units are made to run continuously, check the filters regularly for built-up debris. Frequency of filter changes will depend upon the environment in which the unit is running.

16. To maintain warranty, be sure to use only filters that are approved by the manufacturer.

## **INSTALLATION AND PREPARATION BEFORE OPERATING:**

### **Disclaimer:**

Although instructions and recommendations are included for installation of your Module-Air air filtration system, the manufacturer does not assume responsibility for the installation of this equipment nor shall be held liable for direct or consequential damages resulting from improper methods, structural failure or inadequate supports.

### **Installation: (Diagram on PG. 5)**

Installation methods will depend upon the style of intake options that were selected when your system was ordered. The following is a basic guide line and only a suggestion. A professional installer should be consulted.

One option is to mount Uni-Strut to the building structure, dangle threaded rod through the holes in the strut with a nut and washer 6” down and under the strut. Lift the unit up until the top of the unit taps the threaded rod. Thread the connector nuts onto the ½” studs provided in the top of the unit. Start a ½” nut on the

threaded rod to be used as a jam nut.

Now screw the threaded rod into the connector nuts and tighten up the jam nuts.

The unit can now be lowered and the nuts under the strut can be tightened up to finish the suspension.

The unit can also be mounted on the wall with a simple angle frame, as shown in fig 1. on page 5.

The uni-strut rails, nuts, and threaded rods are not provided with the units. (Uni-strut is available through several places, such as Grainger). .

Again, mounting instructions are only a suggestion. Module-Air is indemnified from any liability related to improper installation. Improper installation could result in person injury and/or damage to the unit.

### **Noise Declaration**

The figures shown are emissions levels and are not necessarily safe working levels. While there is a correlation between the emission and exposure levels, this cannot be used reliably to determine whether or not further precautions are required.

**½"-13 connector nuts**

**Example: Model 3643VT**

The unit is mountable with ½-13 Bolt and nut hardware top and bottom, this ties in to the units main frame and is very secure.

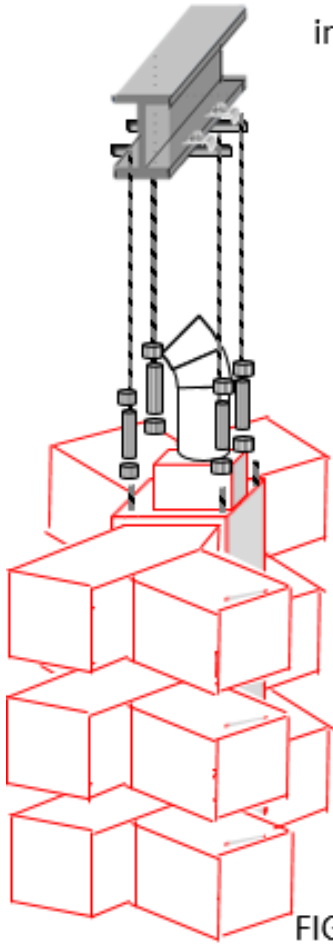

FIG. 2

Figure 2 shows a unit mounted by UNI-STRUT under a hoist beam or building structure.

Connector nuts are used on the provided ½" studs of the unit with a jam nut. Threaded rod is dangled loosely from UNI-STRUT with nuts and washers above and below to allow some vertical movement to ease assembly. Raise the unit up and simply thread into the connector nuts and tighten the jam nut, lower the unit until suspended, then tighten the nuts under the UNI-STRUT to finish.

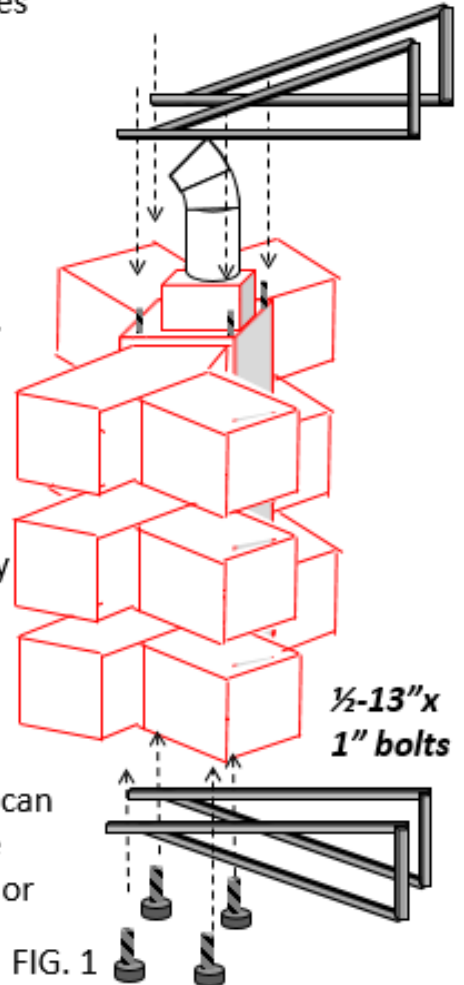
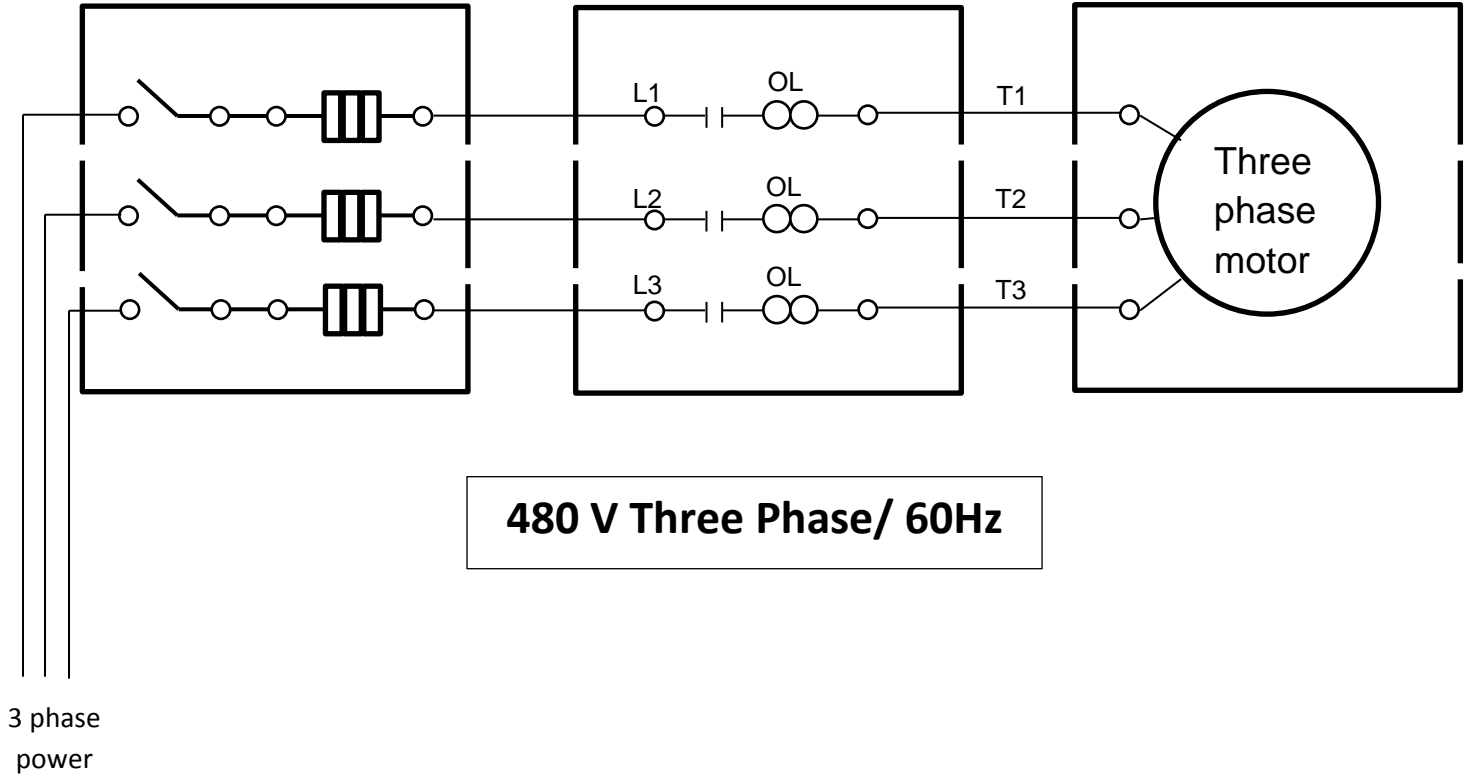
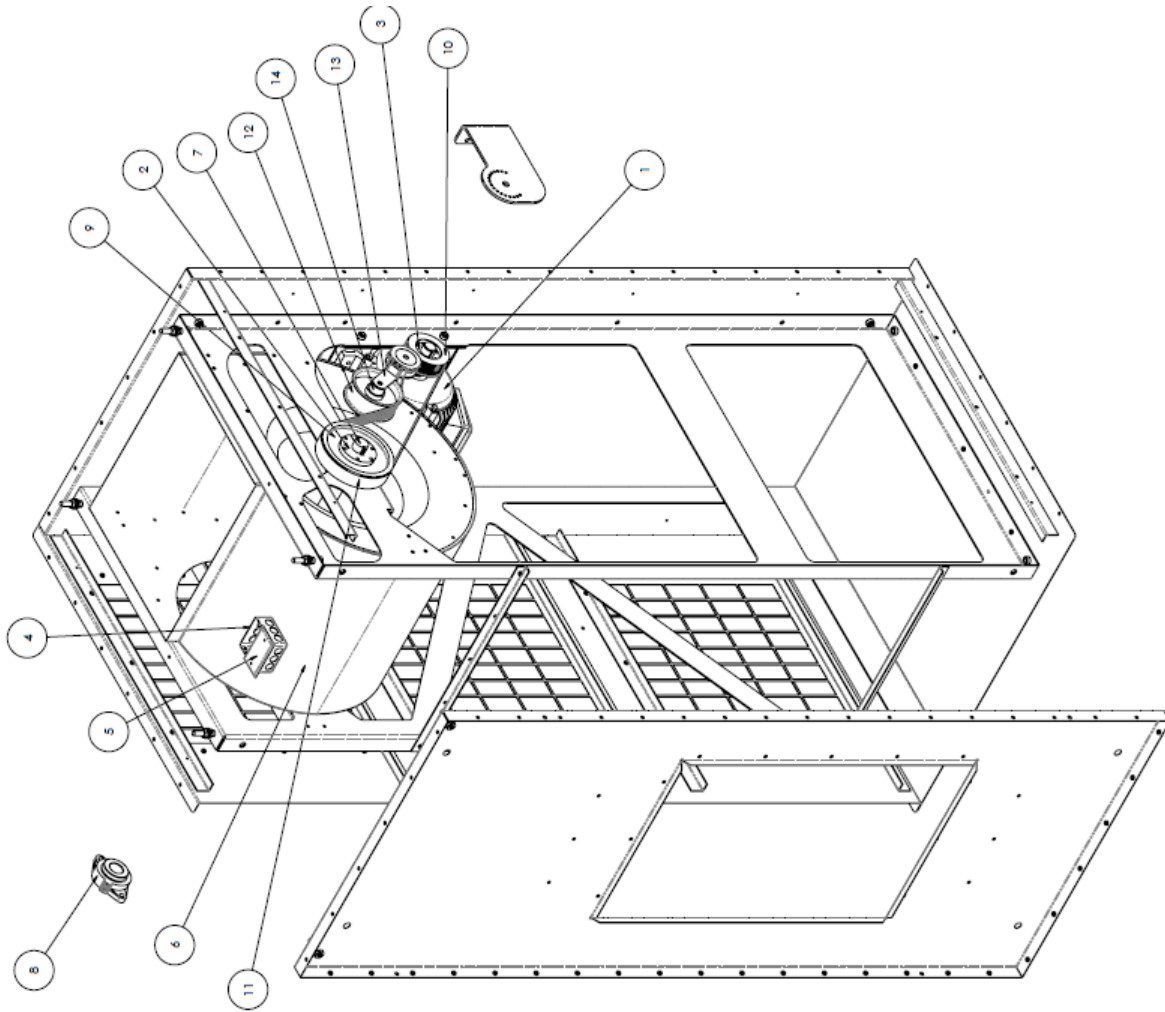

FIG. 1

Figure 1 shows a wall mount, it can be mounted with a simple angle frame on the bottom or the top or both.







ITEM NO.	PART NO.	QTY	DESCRIPTION
1	MAM-10HR-230-480V [215T]	1	10HP 230/480V MOTOR, LEESON
2	MAM-5K1716	1	SK 1-7/16" BUSHING, TB WOODS
3	MAM-SH138	1	SH 1-3/8" BUSHING, TB WOODS
4	MAE-BOX-ASSY	1	ELECTRICAL HANDY BOX ASSEMBLY
5	MAE-COVER	1	ELECTRICAL BOX COVER, GRANGER
6	MAB-18BLOWER	1	18" LAU BLOWER ASSEMBLY (BELT DRIVE)
7	MAB-18SHAFT	1	1.75" DIA. SHAFT FOR 18" LAU BLOWER
8	MAB-1-7/16-DODGE	2	DODGE 1-7/16" BEARING
9	MAB-1.6J775	1	POLY-V SHEAVE, 7.75" DIAMETER
10	MAB-1.6J450	1	POLY-V SHEAVE, 4.5" DIAMETER
11	MAB-330J16 [A330V1]	1	16-RIB POLY-V BELT, 33" LENGTH
12	MAB-F26280	1	AETNA FLAT BELT IDLER
13	MAB-R13001	1	EPSON ROTARY TENSIONER
14	MAM-36SPACER	1	PULLEY SPACER

genuine  

[Module-Air.com](http://Module-Air.com)



## Limited One (1) Year Parts Warranty

MODULE-AIR warrants all MODULE-AIR filtration products to be free from defects in materials or workmanship. This warranty is valid for the original purchaser and for a period of one (1) year from the date of shipment or installation sign off. The liability of MODULE-AIR is limited expressly to the replacement or rebuilding of any article, or part thereof, proven defective, when returned by authorized approval to MODULE-AIR, transportation prepaid, within a reasonable time after the termination of the 365-day warranty. Customer must be able to provide proof of purchase in order to submit a claim.

NOTE: In order to maintain the one year warranty on MODULE-AIR products replacement filters must be purchased from MODULE-AIR for that first year. Proof of filter orders must be kept on file and be readily available upon request by MODULE-AIR.

This warranty is void if the product is installed or assembled in any manner that contradicts the instructions specified by MODULE-AIR, or if the product is dismantled, modified, altered or damaged from improper maintenance, excessive temperature, excessively dirty filters, or other abuse. This warranty does include standard warranties from purchased parts such as motors, blowers, ect. Any part which is determined to be defective in material or workmanship can be shipped, prepaid, to MODULE-AIR or authorized service facility in which case a determination will be made whether to repair or replace the component.

MODULE-AIR is not responsible for shipping costs related to sending replacement parts to customer or customer returning parts to MODULE-AIR for inspection. All freight costs incurred by warranty claims are the responsibility of the customer.

MODULE-AIR is not responsible for any damages to buildings or equipment nor is liable for any injuries caused by filter fires. Customers are responsible for choosing necessary spark arrestor accessories and equipment.

No representative, agent or employee of MODULE-AIR has any authority to modify the terms of this warranty. MODULE-AIR will not be responsible for any consequential or resulting damage which may be claimed to have occurred though the sale or use of such products or parts thereof, which might be defective.

There are no warranties which extend beyond the description contained under this heading, express or implied, including warranties of fitness for a particular purpose.

Any damages incurred while parts are in transit from customer to MODULE-AIR or authorized service facilities are the responsibility of the sender. MODULE-AIR and distributors reserve the right to freeze the warranty claim process if parts are damaged in shipping until customer can be contacted and informed.

Module-Air, L.L.C.  
645 Commerce Court, Suite 10  
Holland, MI 49423  
Phone: 616-990-8005 Fax: 616-796-1213