

LEXUS V8 ENGINES LLC

Client Plug Connection Guide

11-Pin 80 Series Transfer Case Client Plug

80 Series Land Cruiser Transfer Case Control Reference

Prepared for customer installation and workshop technical reference

www.lexusv8.com

Important

This guide covers the 11-pin transfer case client plug used to connect a Lexus V8 Engines LLC standalone harness into the existing 80 Series Land Cruiser transfer case / center differential lock vehicle-side circuit. This plug is a transfer case control interface only; it does not replace the full Toyota chassis harness, dash indicator wiring, fuse circuits, or factory vehicle-side control circuit.

Build-Specific Confirmation

Always confirm wire colors, terminal locations, transfer case actuator/control motor wiring, detection switch operation, L4 circuit operation, speed signal source, and the exact 80 Series Land Cruiser vehicle-side circuit before final customer installation.

Overview

The 11-pin transfer case client plug provides the main customer-side wiring points used to interface with the existing 80 Series Land Cruiser transfer case control circuit. This includes the transfer case actuator/control motor wiring, transfer neutral detection, center differential lock detection, transfer L / L4 status, and the SPD signal where required by the control strategy.

The purpose of this plug is to keep the 80 Series transfer case wiring separate from the main engine, transmission, and cruise control client plugs so the vehicle-side wiring remains clean, serviceable, and easy to test.

Standalone System Note

This is not a full plug-and-play 80 Series Land Cruiser chassis harness. The installer must verify the existing Toyota transfer case actuator/control motor circuit, transfer case position switches, center differential lock switch, speed signal source, dash indicator wiring, fuses, grounds, and any factory vehicle-side control circuits used in the vehicle.

Quick Start: Critical Connections Required

For an 80 Series Land Cruiser vehicle-side transfer case connection, confirm the following circuits before attempting transfer case operation:

Function Group	Circuit	Pin(s)	Wire Color(s)	Connection
Transfer Actuator	Actuator control circuits	Pins 1-4	Green / Red; Green / Black; Green / Yellow; Green	Connect into the existing 80 Series transfer case actuator/control motor circuits exactly as configured for the harness and vehicle-side circuit.
Transfer Neutral Detection	Transfer neutral position switch	Pin 5	Yellow / Green	Connect to the transfer neutral position detection switch circuit.
Center Diff Lock Detection	Center differential lock switch	Pin 6	Pink / Blue	Connect to the center differential lock detection switch circuit.
Transfer L Detection	Transfer low position switch	Pin 7	Blue / Orange	Connect to the transfer L / low-range position detection switch circuit.
L4 Circuit	L4	Pin 8	Blue / Black	Connect to the existing vehicle-side L4 circuit as configured for the supplied transfer case control system.
Vehicle Speed	SPD	Pin 11	Blue	Provide the speed signal required by the transfer case control logic, where applicable.

Transfer Case Wiring Warning

Do not wire by color alone. Confirm function, pin location, signal direction, actuator strategy, and required polarity before connecting into the 80 Series Land Cruiser vehicle-side circuit. Incorrect actuator/control motor or detection switch wiring can cause no 4WD operation, incorrect range indication, unwanted transfer case movement, stuck transfer neutral, diagnostic trouble codes, or transfer case damage.

11-Pin 80 Series Transfer Case Client Plug Pinout

Pin / Terminal	Wire Color	Circuit	Connects To	Notes
Pin 1	Green / Red	To Actuator	Transfer actuator circuit	Actuator/control motor interface wire. Connect only to the correct 80 Series vehicle-side actuator/control motor circuit for the supplied harness.
Pin 2	Green / Black	To Actuator	Transfer actuator circuit	Actuator/control motor interface wire. Do not use as a general power or ground wire.
Pin 3	Green / Yellow	To Actuator	Transfer actuator circuit	Actuator/control motor interface wire. Wire color corrected from supplied typo "Tellow" to Yellow.
Pin 4	Green	To Actuator	Transfer actuator circuit	Actuator/control motor interface wire. Confirm 80 Series vehicle-side actuator/control motor pin location before final connection.
Pin 5	Yellow / Green	Detection SW	Transfer neutral position	Transfer neutral detection switch input/status circuit.
Pin 6	Pink / Blue	Detection SW	Center diff. lock	Center differential lock detection switch input/status circuit.
Pin 7	Blue / Orange	Detection SW	Transfer L position	Transfer low-range position detection switch input/status circuit. Wire color corrected from supplied typo "Orange" to Orange.
Pin 8	Blue / Black	L4	Transfer L4 circuit	L4 circuit connection. Confirm exact signal direction and polarity for the supplied harness before connecting.
Pin 9	N/A	Not Used	N/A	No customer connection shown in the supplied pin list.
Pin 10	N/A	Not Used	N/A	No customer connection shown in the supplied pin list.
Pin 11	Blue	SPD	Vehicle speed signal	Vehicle speed signal used by transfer case control logic where applicable. Confirm speed source and signal type.

Detailed Circuit Descriptions

Pins 1-4 - Transfer Case Actuator Circuits

Actuator Control / Interface Wiring

- Pins 1 through 4 are supplied as the transfer case actuator interface circuits.
- These wires must be connected only to the correct actuator terminals for the supplied transfer case and harness build.
- Do not assume the actuator wires are interchangeable. Incorrect wiring can make the actuator move in the wrong direction, fail to move, or damage the actuator/control system.
- Do not apply direct battery power or ground to these wires unless a build-specific test procedure specifically calls for it.
- Verify the actuator connector, pin location, and transfer case type before operating the system.

Pin 5 - Transfer Neutral Position Detection

Transfer Neutral Detection Switch

- Pin 5 connects to the transfer neutral position detection switch circuit.
- This circuit allows the control system to recognize when the transfer case is in the neutral position.
- Transfer neutral status must be correct before operating or road testing the vehicle.
- Incorrect neutral detection can cause transfer shifting faults, wrong indicator operation, or a vehicle that appears to be in gear but does not drive.
- Verify switch operation with a multimeter or scan data where available.

Pin 6 - Center Differential Lock Detection

Center Diff. Lock Detection Switch

- Pin 6 connects to the center differential lock detection switch circuit.
- This circuit is used to confirm center differential lock status where the transfer case and control system support center diff lock operation.
- Incorrect wiring can cause a flashing or incorrect center diff lock indicator, no lock confirmation, or control logic faults.
- Confirm whether the switch is ground-switched, voltage-switched, or status-only for the exact build.
- Verify the center diff lock indication before road testing on high-traction surfaces.

Pin 7 - Transfer L Position Detection

Transfer Low Range Detection Switch

- Pin 7 connects to the transfer L / low-range position detection switch circuit.
- This circuit tells the transfer case control system when low range has been selected or confirmed.
- Incorrect low-range detection can cause wrong range indication, shift logic issues, or 4WD control faults.
- Confirm switch state in high range and low range before road testing.
- Verify that the vehicle is safely stationary and the transmission is in the correct state before testing low-range shifting.

Pin 8 - L4

L4 Transfer Case Circuit

- Pin 8 is the L4 circuit and uses the Blue / Black wire.
- Connect this wire only to the correct 80 Series vehicle-side L4 circuit for the supplied transfer case control system.
- Confirm whether the L4 circuit is a switched input, indicator/status line, ground-switched circuit, or voltage-switched circuit for the exact build before final connection.
- Do not tie this circuit into other detection switch wires unless the build-specific wiring diagram specifically shows that arrangement.
- Verify L4 status or indicator operation during the first transfer case function test.

Pin 11 - SPD

Vehicle Speed Signal

- Pin 11 provides the SPD / vehicle speed signal connection where required by the transfer case control logic.
- Correct speed signal input can be important for transfer case shifting, range confirmation, warning logic, and diagnostic operation depending on the control strategy.
- Confirm the source of the speed signal: 80 Series transfer case sensor, transmission sensor, factory cluster output, GPS/speed converter, or signal conditioner.
- The control system must receive a compatible signal type and pulse rate for the calibration being used.
- Incorrect or missing speed signal can cause shift complaints, indicator issues, or speed-related DTCs.

Transfer Case Actuator Notes

Transfer case actuator wiring should be treated carefully. The actuator can move the transfer case range or lock mechanism depending on the transfer case design and control strategy. Always confirm the transfer case type and actuator connector before applying power or running tests.

- Do not bench-power the actuator through the client plug unless a specific test procedure has been supplied.
- Make sure the vehicle is secure, wheels are chocked, and the transmission is in a safe state before transfer case operation.
- If the drivetrain is on jack stands, confirm all stands are stable and the tires are clear before testing 4WD or low-range operation.
- Confirm all actuator connector seals, terminals, and locks are in good condition before final installation.
- Route actuator wiring away from exhaust heat, driveshafts, linkages, skid plates, and sharp transfer case edges.

Detection Switch Testing Notes

The detection switch circuits are used so the control system can confirm the actual transfer case position. These should be tested with a multimeter before final connection and, where possible, verified with scan data after wiring.

Detection Function	Pin	Wire Color	Test / Confirmation
Transfer Neutral	Pin 5	Yellow / Green	Verify the switch changes state only when the transfer case is in transfer neutral.
Center Diff. Lock	Pin 6	Pink / Blue	Verify the switch changes state when center differential lock is engaged/confirmed.
Transfer L	Pin 7	Blue / Orange	Verify the switch changes state when low range is engaged/confirmed.
L4	Pin 8	Blue / Black	Verify L4 status or indicator operation according to the supplied transfer case control strategy.

Detection Switch Warning

Do not tie detection switch wires together to force a status signal. False transfer case status can cause the system to believe the transfer case is in a position that it has not actually reached.

Vehicle Speed Signal Notes

The SPD circuit should be connected only to the speed signal source required for the transfer case control strategy. A noisy, missing, or incompatible speed signal can prevent correct transfer case operation on some systems.

- Confirm whether the speed signal comes from the transfer case, transmission, factory cluster, ABS system, GPS converter, or signal conditioner.
- Route speed signal wiring away from ignition coils, alternator wiring, starter wiring, and other high-noise circuits where possible.
- If the system requires a conditioned signal, do not connect a raw or incompatible sensor signal directly.
- Use scan data, an oscilloscope, or a suitable meter to confirm speed signal operation before road testing.

First Test Checklist

Item	Check
Pinout	Confirm all 11 terminal positions match the supplied harness before making final connections.
Actuator Wiring	Pins 1-4 are connected to the correct transfer case actuator terminals and are not swapped.
Transfer Neutral	Transfer neutral detection changes state only when transfer neutral is selected/confirmed.
Center Diff Lock	Center differential lock detection changes state correctly when lock is engaged/confirmed.
Transfer L	Low-range detection changes state correctly when low range is engaged/confirmed.
L4 / Pin 8	Confirm the Blue / Black L4 circuit is connected to the correct vehicle-side L4 wiring and operates correctly during transfer case testing.
SPD	Speed signal source is correct and compatible with the control system.
Indicators	Transfer case, low range, neutral, and center diff lock indicators operate correctly where connected.
DTC Check	Check for transfer case, actuator, speed signal, or position switch fault codes after testing.

Troubleshooting Quick Reference

Symptom	Items to Check
Transfer case will not shift	Check actuator wiring, transfer case control power/ground, brake/neutral prerequisites where applicable, and detection switch feedback.

Symptom	Items to Check
Indicator flashes or never confirms	Check the relevant detection switch circuit, actuator travel, transfer case mechanical movement, and switch ground/reference.
Stuck in transfer neutral	Check transfer neutral detection, actuator movement, linkage/shift rail condition, and whether the control system is receiving conflicting status signals.
Center diff lock will not confirm	Check Pin 6 center diff lock detection switch wiring and confirm the lock mechanism is physically engaging.
Low range does not confirm	Check Pin 7 Transfer L detection wiring, Pin 8 L4 wiring where applicable, and confirm the transfer case has fully shifted into low range.
Speed-related fault or no operation above/below speed	Check Pin 11 SPD source, pulse rate, signal quality, and whether a signal conditioner is required.

Unused Pins

Pin	Wire Color	Note
Pin 9	N/A	No customer connection shown in the supplied pin list.
Pin 10	N/A	No customer connection shown in the supplied pin list.

Included With System

- Standalone harness transfer case control interface wiring where applicable.
- 11-pin transfer case client plug.
- Transfer case actuator interface circuits.
- Transfer neutral, center differential lock, and transfer L detection switch circuits.
- Vehicle speed signal circuit where applicable.

Final Installation Note

When wired correctly, the transfer case client plug allows the 80 Series Land Cruiser transfer case actuator/control motor, position detection switches, L4 circuit, and speed signal wiring to remain organized and separate from the main engine, transmission, and cruise control wiring. This makes the system easier to install, diagnose, and service.

Best Practice

For best results, all transfer case client plug wiring should be soldered or professionally crimped, insulated correctly, strain-relieved, labeled, and routed away from exhaust heat, sharp edges, driveshafts, linkages, skid plates, pedals, steering shafts, and moving suspension components.

80 Series Land Cruiser Vehicle-Side Circuit Reference

This transfer case client plug document is intended for connecting the supplied transfer case interface wiring into the existing 80 Series Land Cruiser center differential lock / transfer case vehicle-side circuit. The customer should retain and verify the factory Toyota circuit where applicable, including the gauge and diff fuses, center diff lock control relay, center diff lock control motor, transfer neutral switch, transfer L4 position switch, center diff lock indicator switch, dash indicators, grounds, and related vehicle-side wiring.

Important 80 Series Note

The client plug is an interface point, not a replacement for the complete Land Cruiser chassis wiring. Use the Toyota wiring diagram below as a reference to identify the existing vehicle-side circuit, then confirm the exact year, market, model, and customer vehicle wiring before final connection.

Client Plug Pin(s)	Client Plug Wire Color(s)	Function	80 Series Vehicle-Side Reference
Pins 1-4	Green / Red; Green / Black; Green / Yellow; Green	Actuator / control motor interface	Existing 80 Series center diff lock control motor / actuator circuit shown in the Toyota diagram.
Pin 5	Yellow / Green	Transfer neutral position detection	Connects to the transfer neutral position switch circuit.
Pin 6	Pink / Blue	Center diff lock detection	Connects to the center differential lock detection / indicator switch circuit where applicable.
Pin 7	Blue / Orange	Transfer L position detection	Connects to the transfer low / L4 position switch circuit.
Pin 8	Blue / Black	L4	Connects to the vehicle-side L4 circuit as configured for the supplied harness.
Pin 11	Blue	SPD	Connects to the required speed signal source for the transfer case control strategy.

Factory Wiring Diagram Reference

The following Toyota center differential lock wiring diagram is included for customer reference when tying the Lexus V8 Engines transfer case client plug into the existing 80 Series Land Cruiser vehicle-side circuit. The diagram shows the power source, fuse block, center diff lock control relay, center diff lock control motor, transfer neutral position switch, transfer L4 position switch, center diff lock indicator switch, dash indicators, grounds, and related vehicle-side connectors.

Diagram Use

Use this diagram as a reference only. The client plug wire colors do not necessarily match the Toyota vehicle-side wire colors shown in the factory diagram. Always connect by circuit function and confirmed pin location, not by color alone.

Toyota Reference Diagram - Center Differential Lock Circuit

CENTER DIFFERENTIAL LOCK

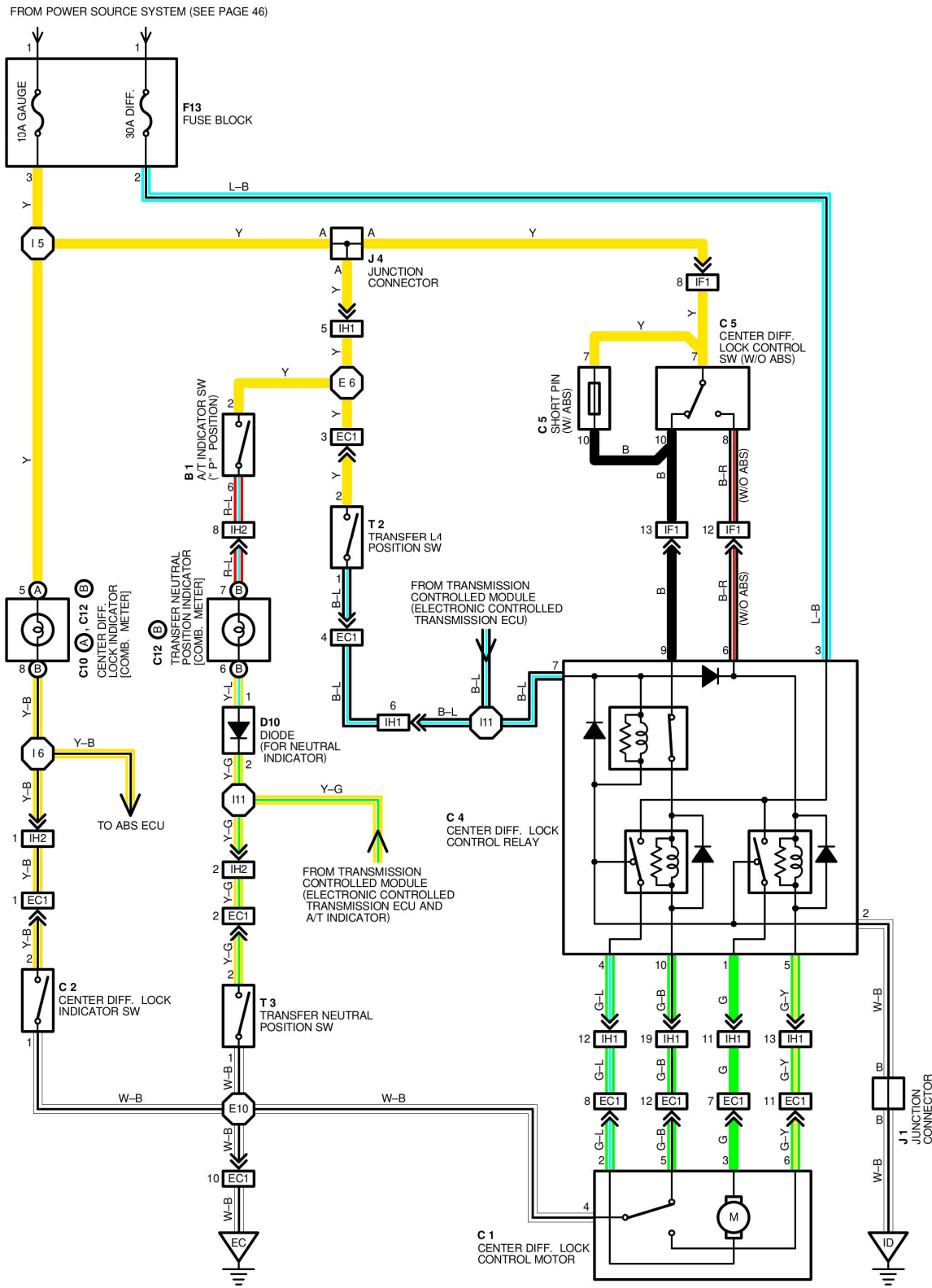

134

Customer reference wiring diagram: Center Differential Lock circuit / 80 Series Land Cruiser vehicle-side transfer case circuit.

Toyota Reference - Service Hints and Connector Views

The factory service-hints page is included to help identify connector views, ground points, splice points, and relay test references when checking the existing 80 Series Land Cruiser vehicle-side transfer case circuit.

Factory Service Hint	Expected Check
C4 Center Diff. Lock Control Relay: terminal 3 to ground	Approx. 12 volts with ignition switch ON.
C4 Center Diff. Lock Control Relay: terminal 2 to ground	Continuity.
C4 Center Diff. Lock Control Relay: terminal 7 to ground	Approx. 12 volts with ignition switch ON and four-wheel drive control lever at L position.

SERVICE HINTS

C 4 CENTER DIFF. LOCK CONTROL RELAY

- 3-GROUND: APPROX. 12 VOLTS WITH IGNITION SW AT **ON** POSITION
- 2-GROUND: ALWAYS CONTINUITY
- 7-GROUND: APPROX. 12 VOLTS WITH IGNITION SW AT **ON** POSITION AND FOUR-WHEEL DRIVE CONTROL LEVER AT **L** POSITION

○ : PARTS LOCATION

CODE	SEE PAGE	CODE	SEE PAGE	CODE	SEE PAGE
B 1	22	C10	A 23	J 4	23
C 1	22	C12	B 23	T 2	22
C 2	22	D10	23	T 3	22
C 4	23	F13	23		
C 5	23	J 1	23		

□ : CONNECTOR JOINING WIRE HARNESS AND WIRE HARNESS

CODE	SEE PAGE	JOINING WIRE HARNESS AND WIRE HARNESS (CONNECTOR LOCATION)
EC1	26	ENGINE WIRE AND TRANSMISSION WIRE (NEAR THE STARTER)
IF1	28	INSTRUMENT PANEL WIRE AND COWL WIRE (INSTRUMENT PANEL CENTER)
IH1	28	ENGINE WIRE AND COWL WIRE (BEHIND GLOVE BOX)
IH2		

▽ : GROUND POINTS

CODE	SEE PAGE	GROUND POINTS LOCATION
EC	26	AIR INTAKE CHAMBER
ID	28	LEFT KICK PANEL

○ : SPLICE POINTS

CODE	SEE PAGE	WIRE HARNESS WITH SPLICE POINTS	CODE	SEE PAGE	WIRE HARNESS WITH SPLICE POINTS
E 6	26	ENGINE ROOM MAIN WIRE	I 6	28	COWL WIRE
E10	26	TRANSMISSION WIRE	I11		
I 5	28	COWL WIRE			

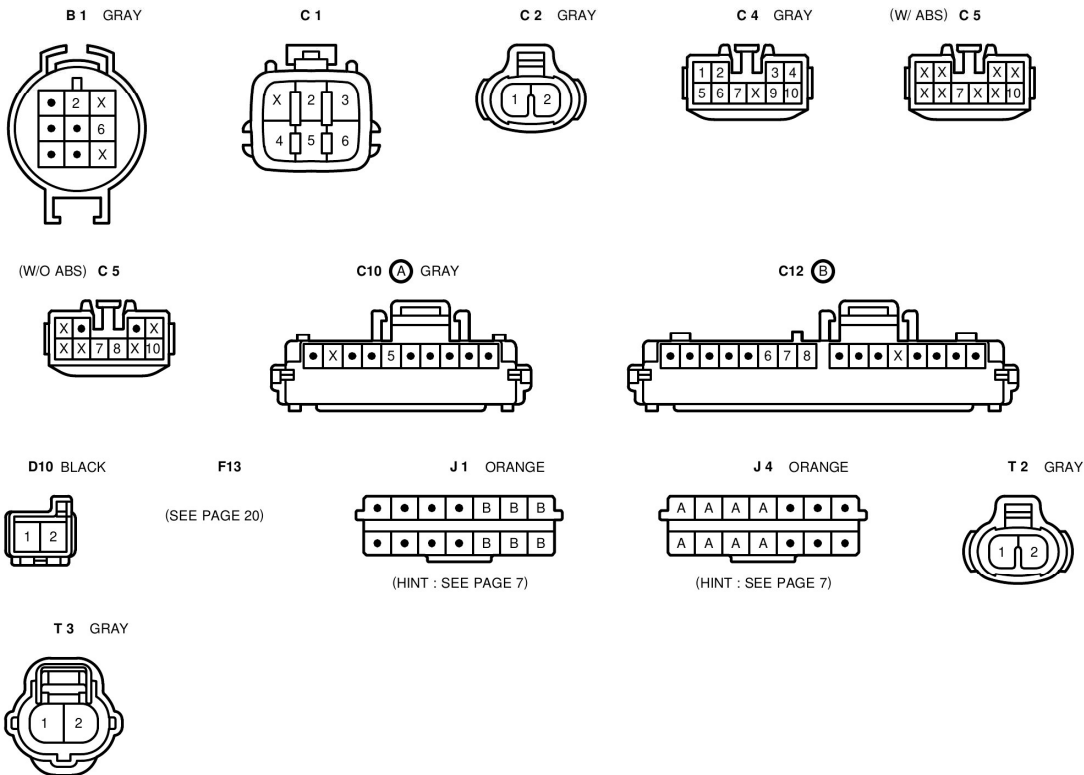

Customer reference: service hints, connector views, joining connectors, ground points, and splice points for the factory center differential lock circuit.

Lexus V8 Engines LLC
 Website: www.lexusv8.com
 Technical support and build-specific wiring requirements should be confirmed during the harness build process or through the client form.