

# SAUTER North America Inc.

1116 Centre Rd., Auburn Hills, MI 48326 USA

Phone: 734.207.0900

Fax: 734.207.0901

Mobile: 734 395 1137

www.sauter-group.com

For exceptional support and service please call our Toll-Free number at 1-844-44SAUTER (or 1.844.447.2883) and visit <http://www.sauter-group.com> to learn more about our line of direct drive indexing turrets and live tooling products.



# SAUTER

Mit uns dreht die Welt!

## SAUTER Crown-Turret used for robotic milling application.

Crown-type tool turret used for this presentation: **0.5.170.112**

Turret shown with a belt drive-unit. Cables, Hydraulic/Pneumatic connections/lines and Lubrication lines not shown within this presentation.

Tools shown (reference only):

1. Drill bit for an 8-mm...
2. Tap tool for M8 thread...
3. Face-Mill-Tool at 3in-Dia.
4. End-Mill-Tool at 24mm-OD

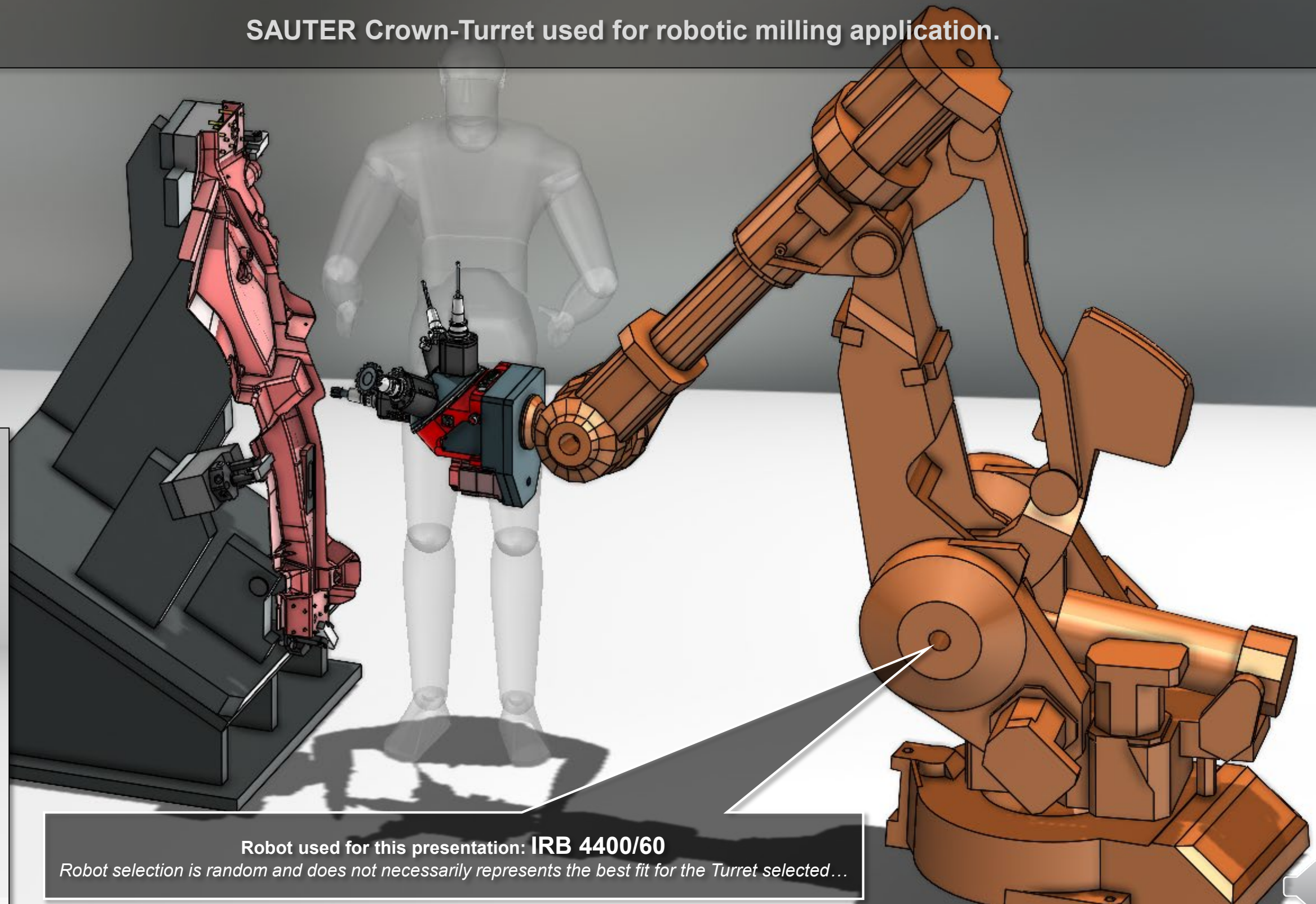
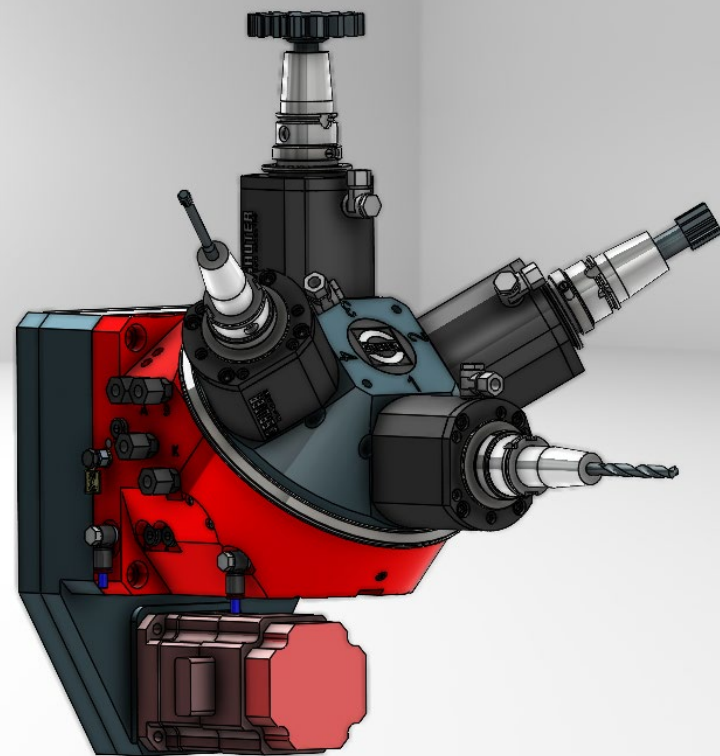

Robot used for this presentation: **IRB 4400/60**

Robot selection is random and does not necessarily represents the best fit for the Turret selected...

# SAUTER North America Inc.

1116 Centre Rd., Auburn Hills, MI 48326 USA  
Phone: 734.207.0900  
Fax: 734.207.0901  
Mobile: 734 395 1137  
www.sauter-group.com

For exceptional support and service please call our Toll-Free number at 1-844-44SAUTER (or 1.844.447.2883) and visit <http://www.sauter-group.com> to learn more about our line of direct drive indexing turrets and live tooling products.

Crown-type tool turret : 0.5.170.112

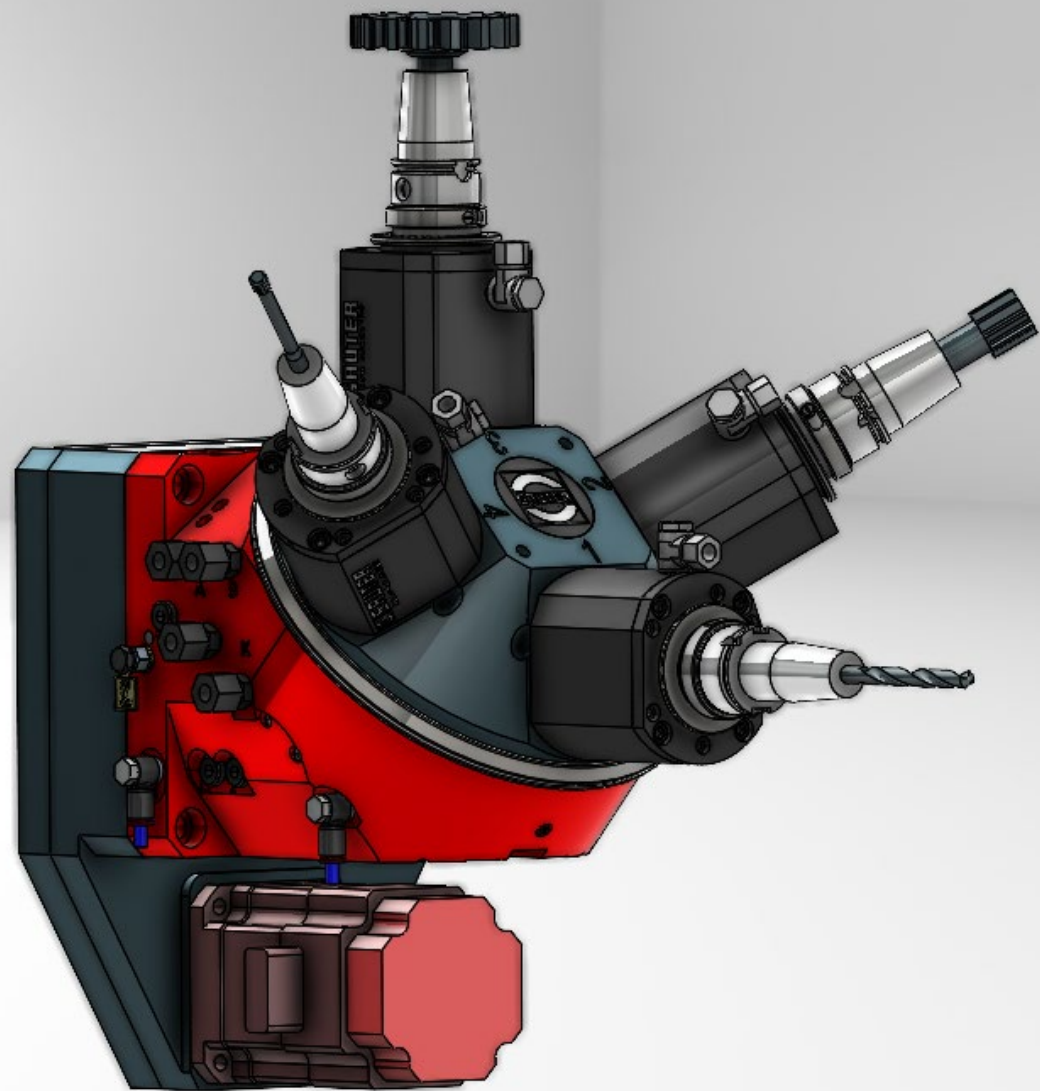

Visit: [www.sauter-group.com](http://www.sauter-group.com) to explore all Crown-type Tool Turret styles & sizes available.

