

Produktinformation PI 55.3

GILDEMEISTER

CTX Gamma

Trifix

2010-12-21



Inhaltsverzeichnis

– Werkzeuganordnung	5
– CTX gamma 1250 V10 - 12fach - VDI 40	6
– CTX gamma 1250/2000 V6 - 12fach - VDI 50	12

Werkzeugzuordnung Bearbeitung Vor- und Rückwärts

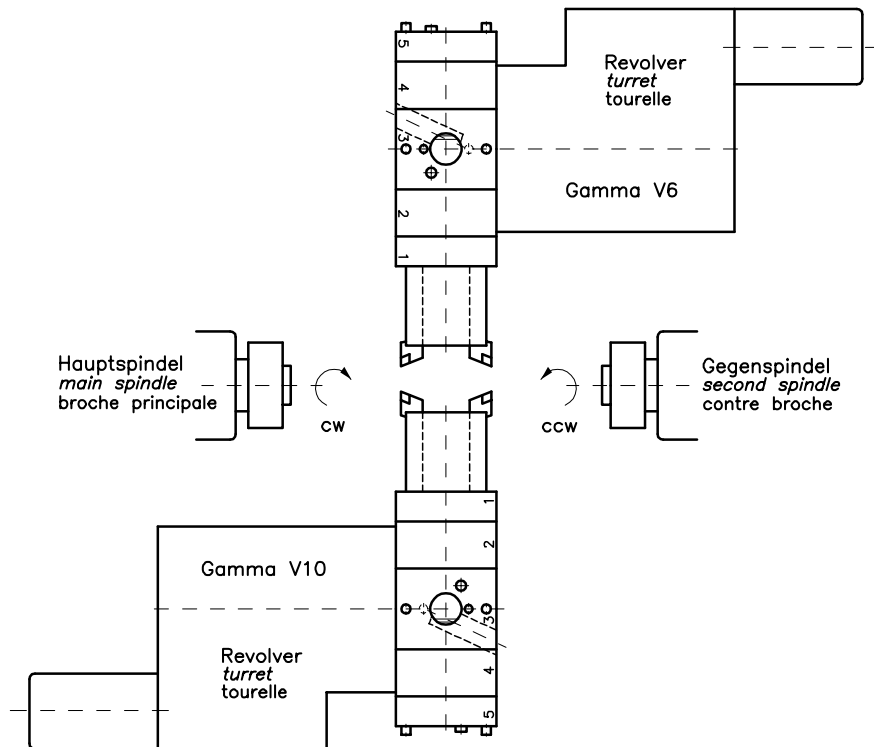

Werkzeugrevolver	Ausführung	‘Rechts‘
Werkzeugscheibe	Ausführung	‘Links‘
	Stützstifte	‘vorn, hinten‘

Präzisionsschnittstelle vorbereitet für VDI Hochgenau SAUTER Trifix

Werkzeughalter / Spindelköpfe

90°-Adapter-Duo-Rechts

Werkzeughalter DIN 69880-Form E2

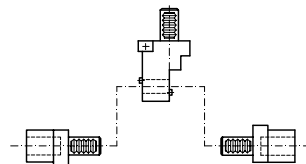

Werkzeughalter DIN 69880-Form E2

Bohrstangenhalter

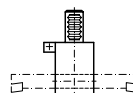

90°-Spindelkopf-Duo-Rechts

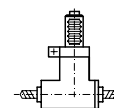

90°-Spindelkopf-Links oder Universal

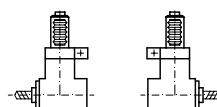

90°-Spindelkopf-Rechts oder Universal

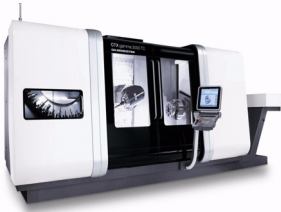

Statische Werkzeughalter, Spindelköpfe

VDI 40

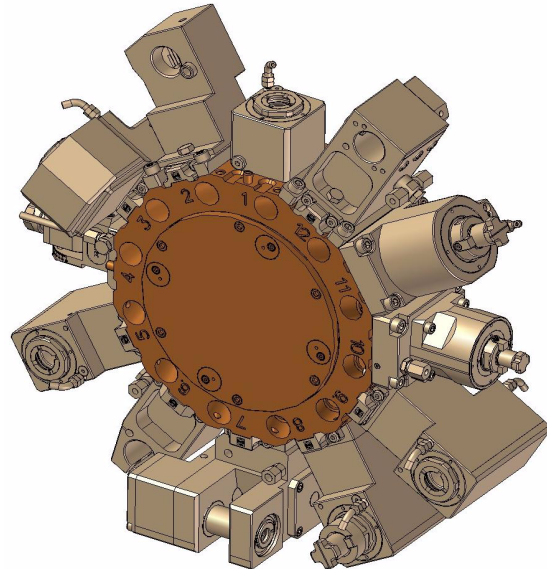
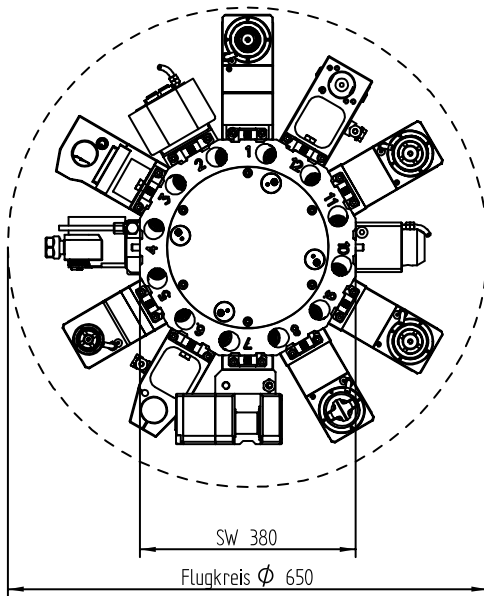

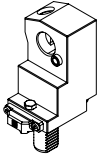
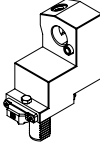
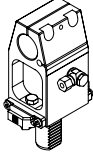
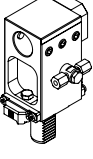
Model	Nennlänge, Nennhöhe	KSS-Zufuhr	Übersetzung	Werkzeugaufnahme	Bestell-Nr.	
	90° - Adapter mit beidseitiger Aufnahme DIN 69 880	100	extern	Ø 40	Links 133433	Rechts 133434
	90° - Adapter zurückgesetzt Aufnahme DIN 69 880	100	extern	Ø 40	Links 133440	Rechts 133444
	Bohrstangenhalter mit Klemmung	100	extern	Ø 32	133445	
	Bohrstangenhalter	100	intern / extern*	Ø 40	133385	

*Kühlschmierstoffdruck 5-25 bar - Filterung 50µm

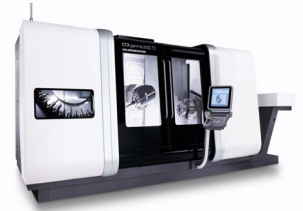

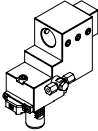
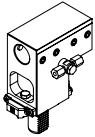
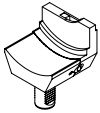
Model	Nennlänge,Nennhöhe	KSS-Zufuhr	Übersetzung	Werkzeugaufnahme	Bestell-Nr.	
	Bohrstangenhalter zurückgesetzt	100	intern / extern*	Ø 40	133447	
	Doppel - Bohrstangenhalter	120	intern / extern*	Ø 40	Universal 133448	
	Abstechhalter für Stechklingen ISCAR	85,5	extern	26	Universal 111627	Universal Überkopf 111628
		85,5	extern	32	Universal 111629	Universal Überkopf 111630

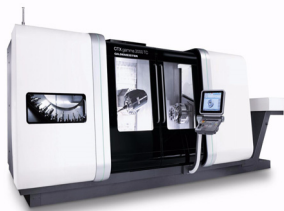

Statische Werkzeughalter, Spindelköpfe

VDI 40

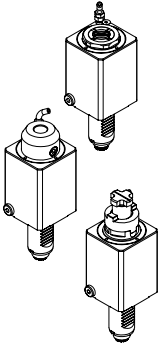
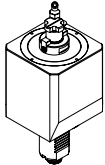
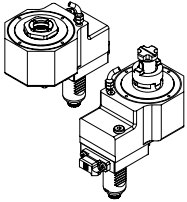

Model	Nennlänge,Nennhöhe	KSS-Zufuhr	Übersetzung	Werkzeugaufnahme	Bestell-Nr.		
 Spindelkopf 0°	95	extern	1,0 (1:1)	DIN 6499 - ER 32	101714		
	117	extern	1,0 (1:1)	DIN 6499 - ER 32	113179		
	103	intern / extern*	1,0 (1:1)	DIN 6499 - ER 32	111384		
	123	intern / extern*	1,0 (1:1)	DIN 6499 - ER 32	109240		
	112,5	extern	0,25 (1:4)	DIN 6499 - ER 20	109737		
	111	extern	1,0 (1:1)	DIN 1835 - B 20	113186		
	133	extern	1,0 (1:1)	DIN 1835 - B 20	113187		
	111	intern / extern*	1,0 (1:1)	DIN 1835 - B 20	113183		
	130	intern / extern*	1,0 (1:1)	DIN 1835 - B 20	113184		
	102	extern	1,0 (1:1)	DIN 6358 - 22	102181		
 Spindelkopf 0°	125	extern	1,0 (1:1)	DIN 6358 - 22	131944		
 Spindelkopf 0° mit Achsversatz	99	extern	2,0 (2:1)	DIN 6499 - ER 32	Links 133424	Rechts 133425	Universal 133426
	108	intern / extern*	2,0 (2:1)	DIN 6499 - ER 32	Links 133427	Rechts 133428	Universal 133429
	117	extern	2,0 (2:1)	DIN 6358 - 22	Links 133430	Rechts 133431	Universal 133432

*Kühlschmierstoffdruck 5-25 bar - Filterung 50µm

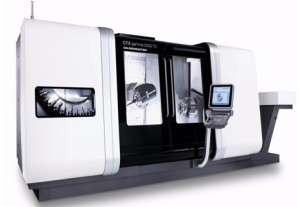

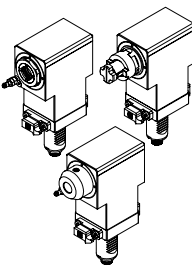
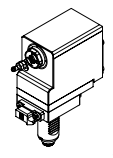
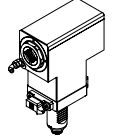
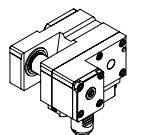
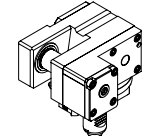
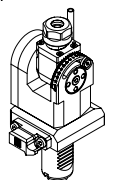
Model	Nennlänge, Nennhöhe	KSS-Zufuhr	Übersetzung	Werkzeugaufnahme	Bestell-Nr.			
	100	extern	1,0 (1:1)	DIN 6499 - ER 32	Links 133405	Rechts 133406	Universal 133407	
	100	intern / extern*	1,0 (1:1)	DIN 6499 - ER 32	Links 133411	Rechts 133412	Universal 133382	
	100	extern	2,0 (2:1)	DIN 6499 - ER 32	Links 133408	Rechts 133409	Universal 133410	
	100	extern	1,0 (1:1)	DIN 1835 - B 20	Links 133413	Rechts 133414	Universal 133415	
	100	intern / extern*	1,0 (1:1)	DIN 1835 - B 20	Links 133416	Rechts 133417	Universal 133418	
	100	extern	2,0 (2:1)	DIN 6358 - 22	Links 133419	Rechts 133420	Universal 133421	
	Spindelkopf 90° zurückgesetzt	125	extern	0,25 (1:4)	DIN 6499 - ER 20	Links 133402	Rechts 133403	Universal 133404
	2-fach Spindelkopf 90°	100	extern	1,0 (1:1)	DIN 6499 - ER 32	Links 133399	Rechts 133400	Universal 133401
	Spindelkopf 90° mit Sägeblattaufnahme	100	extern	3,0 (3:1)	Ø100 - 22/27	Links 133396	Rechts 133397	
	Spindelkopf 90° mit Sägeblattaufnahme ±25° Schwenkbar	100	extern	3,0 (3:1)	Ø100 - 22/27	133395		
	Spindelkopf ±90°	81	extern	1,0 (1:1)	DIN 6499 - ER 25	133423		
		81	intern / extern*	1,0 (1:1)	DIN 6499 - ER 25	133422		

*Kühlschmierstoffdruck 5-25 bar - Filterung 50µm

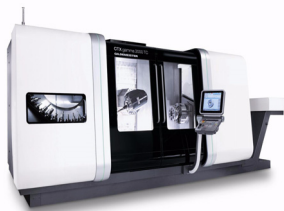

Statische Werkzeughalter, Spindelköpfe
für Schwerlastbearbeitung

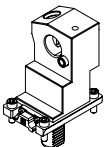
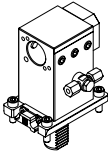
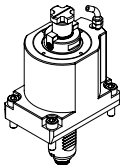
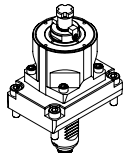

VDI 40

Model	Nennlänge,Nennhöhe	KSS-Zufuhr	Übersetzung	Werkzeugaufnahme	Bestell-Nr.
 <p>90° - Adapter mit Flanschbefestigung, mit beidseitiger Aufnahme DIN 69 880</p>	100	extern		Ø 40	Links 133435 Rechts 133436
 <p>Bohrstangenhalter mit Flanschbefestigung</p>	100	intern / extern*		Ø 40	133446
 <p>Spindelkopf 0° mit Flanschbefestigung</p>	125	extern	1,0 (1:1)	DIN 6358 - 22	132067
 <p>Spindelkopf 0° mit Flanschbefestigung</p>	125	extern	4,0 (4:1)	DIN 6358 - 22	132358

*Kühlschmierstoffdruck 5-25 bar - Filterung 50µm

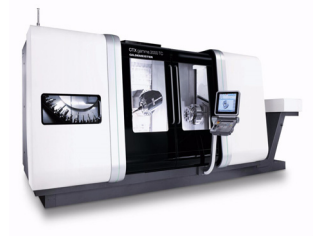



Model	Nennlänge,Nennhöhe	KSS-Zufuhr	Übersetzung	Werkzeugaufnahme	Bestell-Nr.
-------	--------------------	------------	-------------	------------------	-------------

SAUTER Schnellwechselsystem MODIFIX

	Auf Anfrage				PI56
---	-------------	--	--	--	------

Zubehör

	Spannzangenaufnahme für Bohrstangenhalter Kühlschmierstoff intern		DIN 6499 - ER 32		112698
---	--	--	------------------	--	--------

	Verschlussstopfen aus Stahl mit O-Ring				114575
---	--	--	--	--	--------

Erforderliche Schlüssel, Spannzangen und Dichtscheiben sind nicht im Lieferumfang enthalten

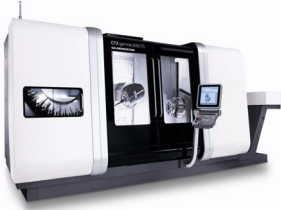

Statische Werkzeughalter, Spindelköpfe



VDI 50

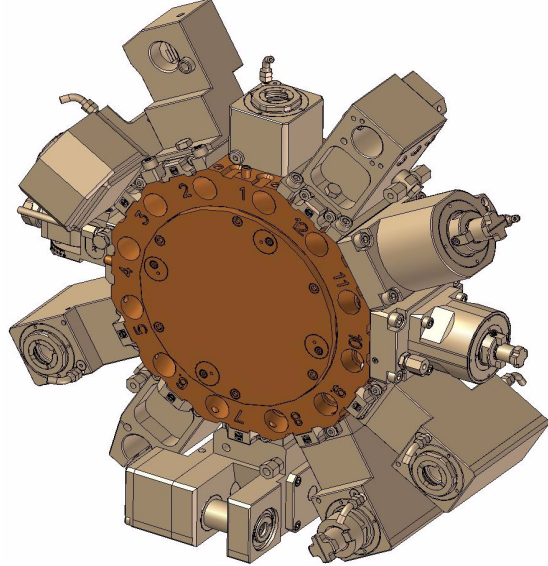
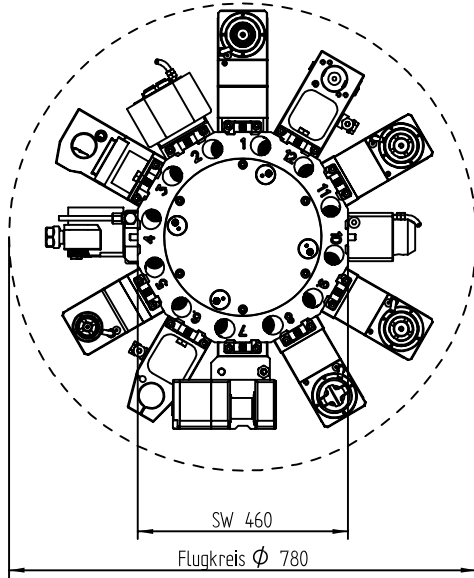

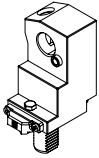
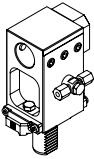
Model	Nennlänge,Nennhöhe	KSS-Zufuhr	Übersetzung	Werkzeugaufnahme	Bestell-Nr.	
 <p>90° - Adapter mit beidseitiger Aufnahme DIN 69 880</p>	120	extern		Ø 50	Links 137371	Rechts 137372
 <p>Bohrstangenhalter</p>	120	intern / extern*		Ø 50	137374	

*Kühlschmierstoffdruck 5-25 bar - Filterung 50µm

GILDEMEISTER - CTX gamma 1250/2000 V6 - SAUTER Trifix

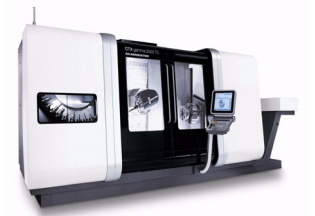

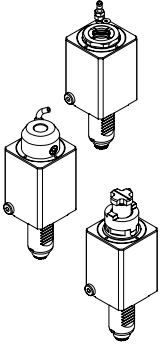
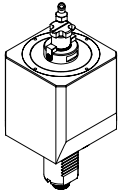
Model	Nennlänge,Nennhöhe	KSS-Zufuhr	Übersetzung	Werkzeugaufnahme	Bestell-Nr.
	120	extern	1,0 (1:1)	DIN 6499 - ER 40 I	106164
	155	extern	1,0 (1:1)	DIN 6499 - ER 40 A	121998
	133	intern / extern*	1,0 (1:1)	DIN 6499 - ER 40 I	109420
	155	intern / extern*	1,0 (1:1)	DIN 6499 - ER 40 A	121992
	128,5	extern	0,25 (1:4)	DIN 6499 - ER 20	109748
	172	extern	1,0 (1:1)	DIN 1835 - B 25	119803
	135	extern	1,0 (1:1)	DIN 6358 - 22	123213
	138	extern	1,0 (1:1)	DIN 6358 - 27	107611
	Spindelkopf 0°	extern	1,0 (1:1)	DIN 6358 - 27	137493



Statische Werkzeughalter, Spindelköpfe VDI 50

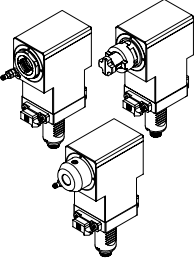
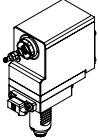
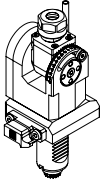

Model	Nennlänge,Nennhöhe	KSS-Zufuhr	Übersetzung	Werkzeugaufnahme	Bestell-Nr.		
 Spindelkopf 90°	110	extern	1,0 (1:1)	DIN 6499 - ER 40 I	links 137376	rechts 137377	Universal 137378
	110	extern	1,0 (1:1)	DIN 6499 - ER 40 A	Links 137379	Rechts 137380	Universal 137382
	110	intern / extern*	1,0 (1:1)	DIN 6499 - ER 40 I	Links 137394	Rechts 137395	Universal 137396
	110	intern / extern*	1,0 (1:1)	DIN 6499 - ER 40 A	Links 137397	Rechts 137398	Universal 137399
	110	extern	2,0 (2:1)	DIN 6499 - ER 40 I	Links 137385	Rechts 137386	Universal 137387
	110	extern	2,0 (2:1)	DIN 6499 - ER 40 A	Links 137388	Rechts 137389	Universal 137390
	110	extern	2,0 (2:1)	DIN 6358 - 27	Links 137400	Rechts 137402	Universal 137403
 Spindelkopf 90° zurückgesetzt	113	extern	0,25 (1:4)	DIN 6499 - ER 20	Links 137391	Rechts 137392	Universal 137393
 Spindelkopf ±90°	123	extern	1,0 (1:1)	DIN 6499 - ER 40	Links 137416	Rechts 137417	

*Kühlschmierstoffdruck 5-25 bar - Filterung 50µm

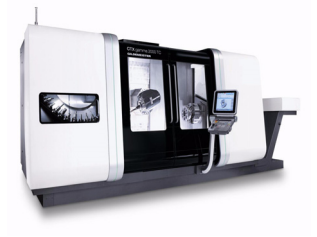

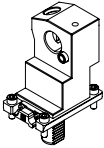
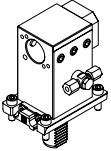
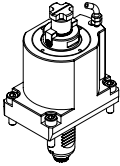
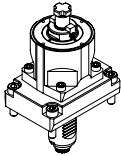
Model	Nennlänge,Nennhöhe	KSS-Zufuhr	Übersetzung	Werkzeugaufnahme	Bestell-Nr.
 <p>90° - Adapter mit Flanschbefestigung, mit beidseitiger Aufnahme DIN 69 880</p>	120	extern		Ø 50	Links 137494 Rechts 137502
 <p>Bohrstangenhalter mit Flanschbefestigung</p>	120	intern / extern*		Ø 50	137503
 <p>Spindelkopf 0° mit Flanschbefestigung</p>		extern	1,0 (1:1)	DIN 6358 - 27	137505
 <p>Spindelkopf 0° mit Flanschbefestigung</p>		extern	4,0 (4:1)	DIN 6358 - 27	137507



Statische Werkzeughalter, Spindelköpfe



VDI 50

Model	Nennlänge,Nennhöhe	KSS-Zufuhr	Übersetzung	Werkzeugaufnahme	Bestell-Nr.
-------	--------------------	------------	-------------	------------------	-------------

SAUTER Schnellwechselsystem MODIFIX



Auf Anfrage

PI56

Zubehör



Verschlussstopfen aus Stahl mit O-Ring

114573

Erforderliche Schlüssel, Spannzangen und Dichtscheiben sind nicht im Lieferumfang enthalten

*Kühlschmierstoffdruck 5-25 bar - Filterung 50µm

GILDEMEISTER - CTX gamma 1250/2000 V6 - SAUTER Trifix