



SAUTER





Mit uns dreht die Welt!

Angetriebene Werkzeuge und statische Werkzeughalter

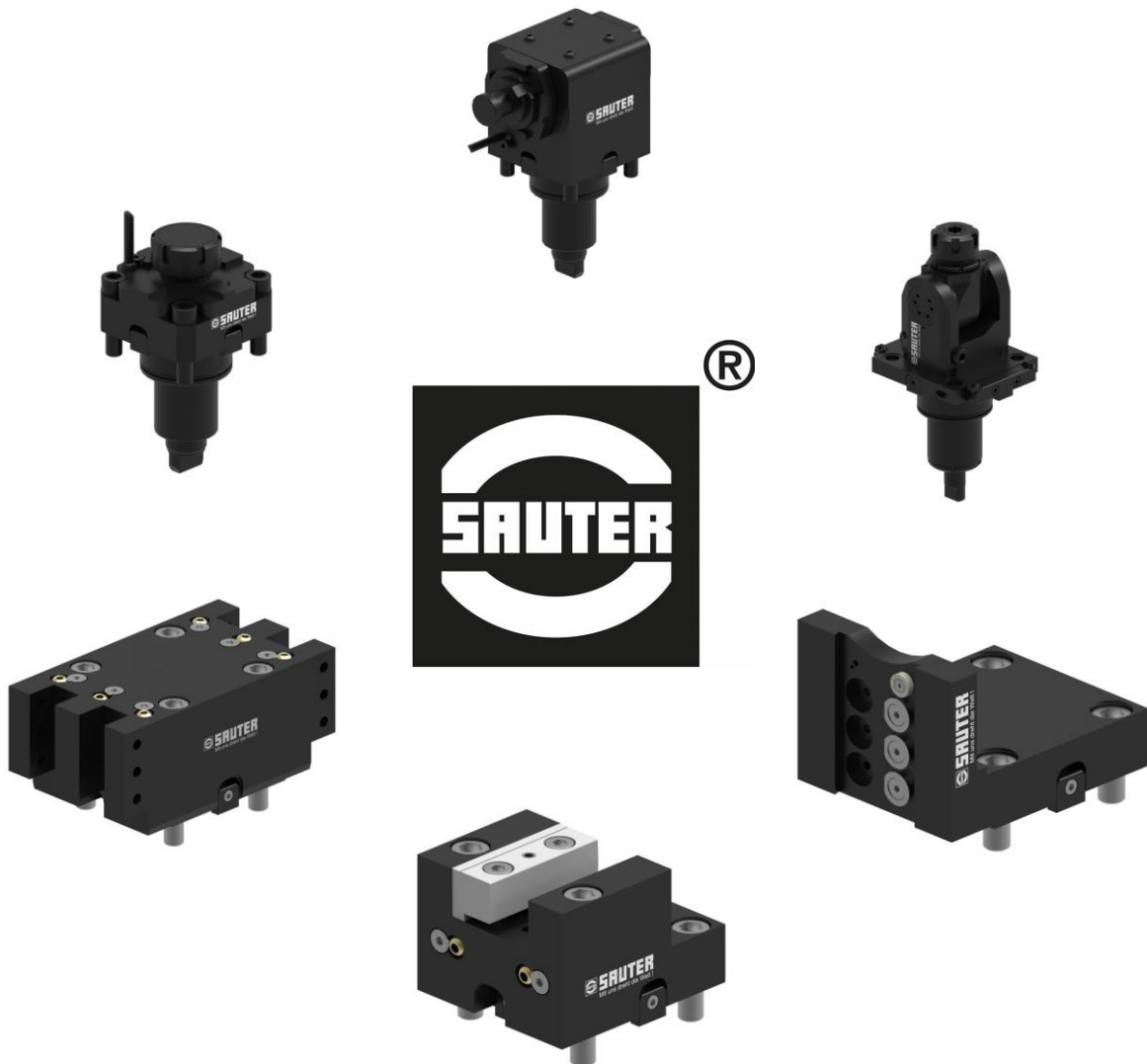
Driven tools and static tool holders

BMT-65



BMT-65	Werkzeugspanner Tools Clamping	Mittelhöhe [mm] Center Height [mm]	Max. Geschwindigkeit [1/min] Max. Speed [1/min]	Übersetzung Ratio	Extern External	Intern Internal
	ER 32 - DIN ISO 15488 *		8000	i=1:1	178036	
	ER 32 - DIN ISO 15488 *		6000	i=1:1		178039
	ER 32 - DIN ISO 15488 *	72	8000	i=1:1	178042	
	ER 32 - DIN ISO 15488 *	72	12000	i=1:1		178045
	ER 32 - DIN ISO 15488 *	100	8000	i=1:1	178048	178051
	Ø22	72	6000	i=1:1	178053	
	Ø22	100	6000	i=1:1	178055	
	ER 32 - DIN ISO 15488 *	72	8000	i=1:1	178057	
	ER 32 - DIN ISO 15488 *	100	8000	i=1:1	178060	
	ER 25 - DIN ISO 15488 *	75	6000	i=1:1	178062	178071

*DIN ISO 15488 alt DIN 6499

BMT-65	Werkzeugspanner Tools Clamping	Mittelhöhe [mm] Center Height [mm]	Kühlmittel Coolant	Sauter Teil Nr. Sauter Part No.
	□ 25mm	80	Extern	178558
	□ 1"	80	Extern	178559
	□ 25mm	80	Extern	178560
	□ 1"	80	Extern	178561
	□ 20mm	75	Extern	178454
	□ 25mm	70	Extern	178457
	□ 1"	70	Extern	178562
	□ 32mm	80	Extern	178459
	∅ 40mm	72	Intern/Extern	178461
	∅ 50mm	72	Intern/Extern	178563
	∅ 1.5"	72	Intern/Extern	178564
	∅ 2"	72	Intern/Extern	178565
	∅ 40mm	100	Intern/Extern	178566
	∅ 1.5"	100	Intern/Extern	178567
	∅ 40mm	115	Intern/Extern	178568
	∅ 1.5"	115	Intern/Extern	178569
	∅ 40mm	100	Intern/Extern	151239

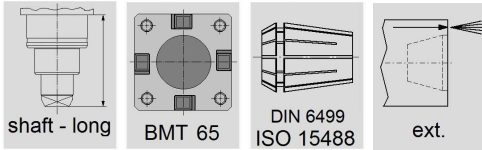

ext. 80 bar

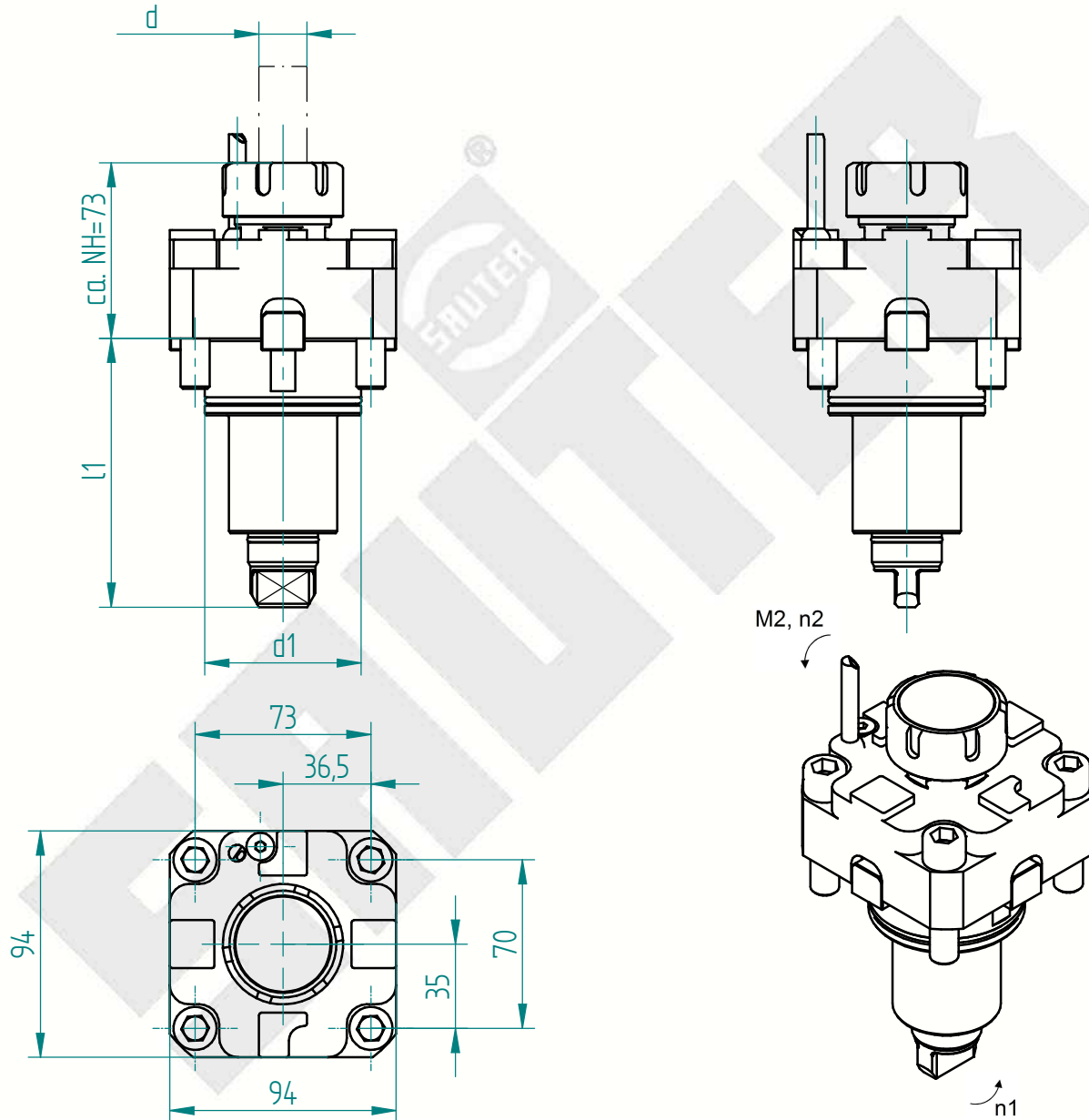

Schnittstelle Revolver <i>interface tool turret</i>		Kupplung <i>coupling</i>	Drehmoment <i>torque</i>	Drehzahl <i>tool speed</i>	Leistung <i>output</i>	Übersetzung <i>gear ratio</i>	Wkzg.Aufnahme Spannbereich <i>tool holding fixture clamping range</i>	Ausführung <i>version</i>	Bestell-Nr. <i>order N°</i>
Schaft / BG <i>shank / size</i>									
d1 mm	l1 mm		M2 max Nm	n2 max 1/min	P max KW	i = n1: n2	Spannbereich d <i>chucking capacity d</i>		
65	112.0	BMT BMT 65	50.0	8000	0.0	1.000	ISO 15488 - 32 - A 2-20	gerade <i>straight</i>	178036

Erforderliche(r) Schlüssel zur Werkzeugspannung / *necessary key(s) for tool clamping*
(nicht im Lieferumfang enthalten / *not included in delivery*)

178629



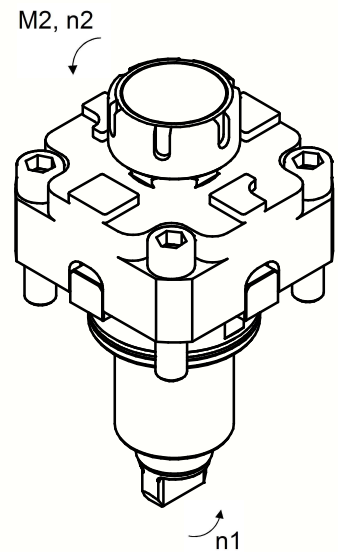
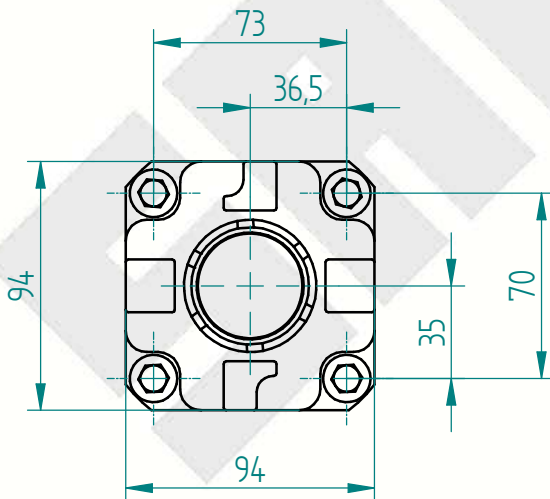
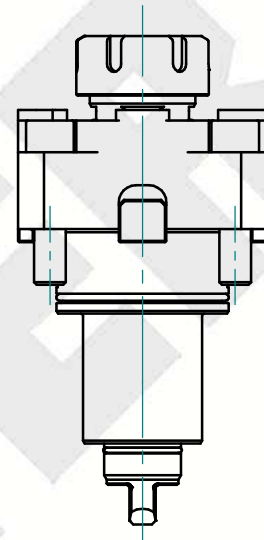
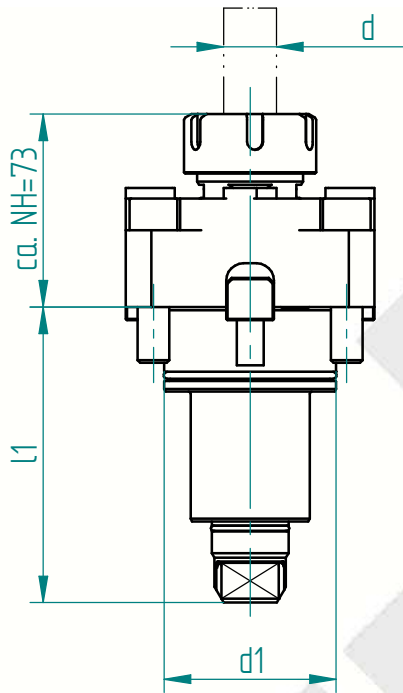
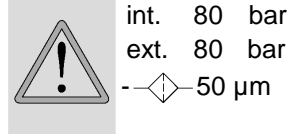
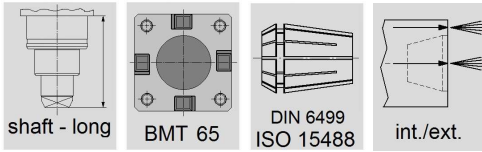

Schnittstelle Revolver <i>interface tool turret</i>		Kupplung <i>coupling</i>	Drehmoment <i>torque</i>	Drehzahl <i>tool speed</i>	Leistung <i>output</i>	Übersetzung <i>gear ratio</i>	Wkzg.Aufnahme Spannbereich <i>tool holding fixture clamping range</i>	Ausführung <i>version</i>	Bestell-Nr. <i>order N°</i>
Schaft / BG <i>shank / size</i>									
d1 mm	l1 mm		M2 max Nm	n2 max 1/min	P max KW	i = n1: n2	Spannbereich d <i>chucking capacity d</i>		
65	112.0	BMT BMT 65	50.0	6000	0.0	1.000	ISO 15488 - 32 - A 2-20	gerade <i>straight</i>	178039

Erforderliche(r) Schlüssel zur Werkzeugspannung / *necessary key(s) for tool clamping*
(nicht im Lieferumfang enthalten / *not included in delivery*)

178629



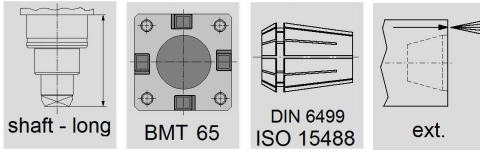

ext. 80 bar

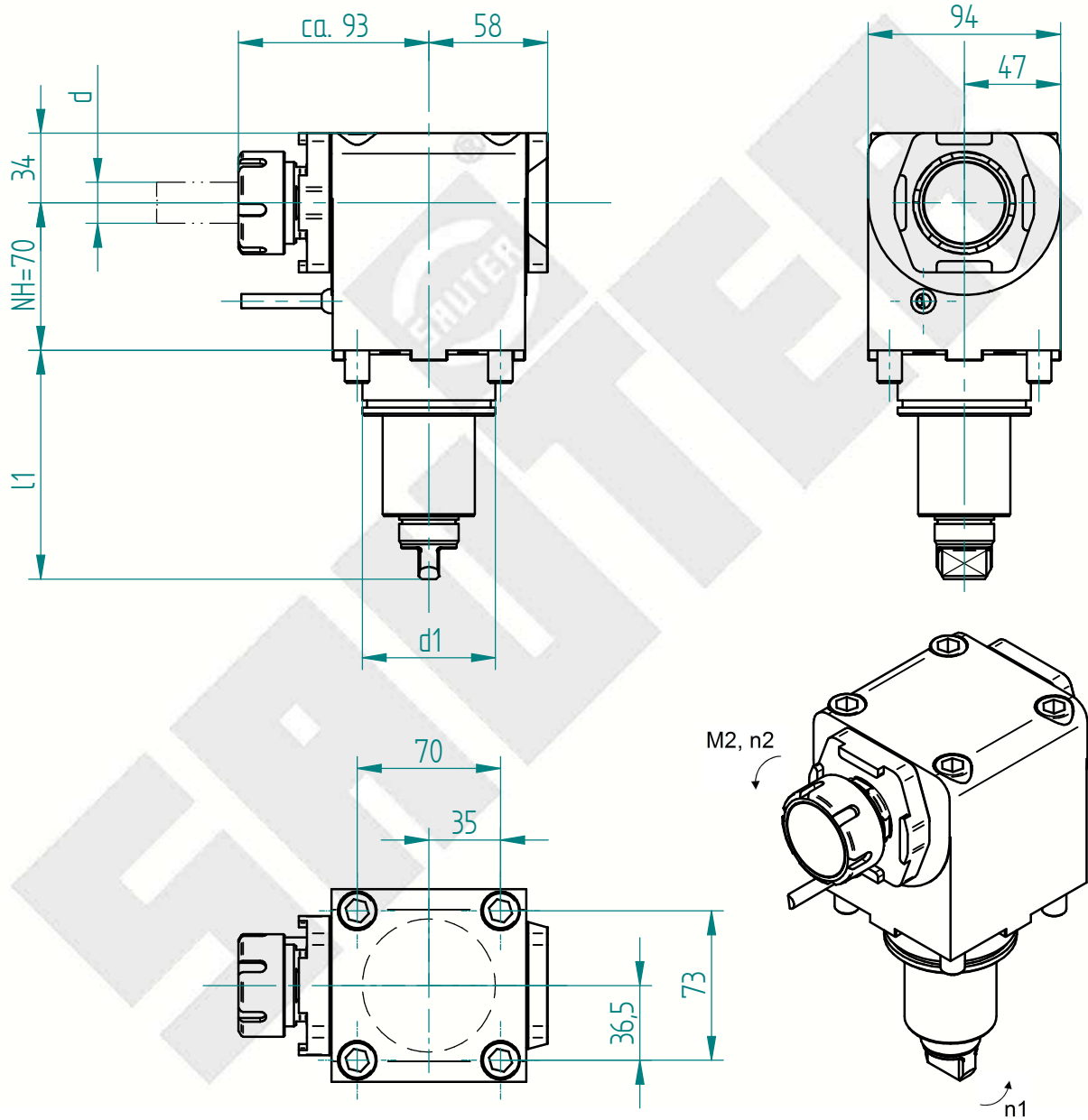

Schnittstelle Revolver <i>interface tool turret</i>		Kupplung <i>coupling</i>	Drehmoment <i>torque</i>	Drehzahl <i>tool speed</i>	Leistung <i>output</i>	Übersetzung <i>gear ratio</i>	Wkzg.Aufnahme Spannbereich <i>tool holding fixture clamping range</i>	Ausführung <i>version</i>	Bestell-Nr. <i>order N°</i>
Schaft / BG <i>shank / size</i>									
d1 mm	l1 mm		M2 max Nm	n2 max 1/min	P max KW	i = n1: n2	Spannbereich d <i>chucking capacity d</i>		
65	112.0	BMT BMT 65	50.0	8000	0.0	1.000	ISO 15488 - 32 - A 2-20	universal universal	178042

Erforderliche(r) Schlüssel zur Werkzeugspannung / *necessary key(s) for tool clamping*
(nicht im Lieferumfang enthalten / *not included in delivery*)

178629



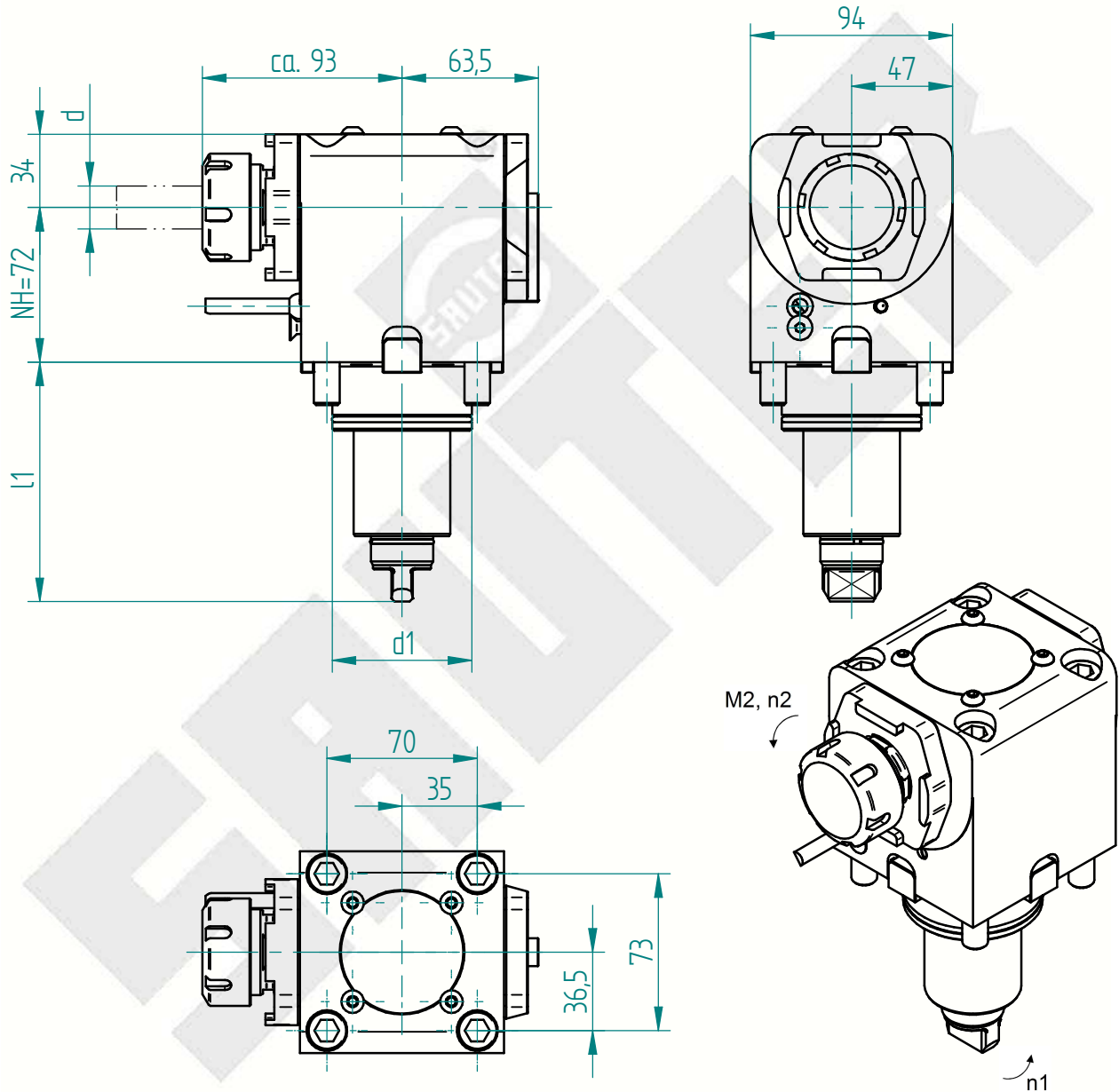
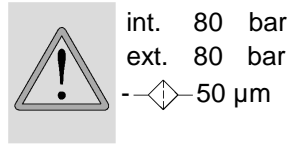
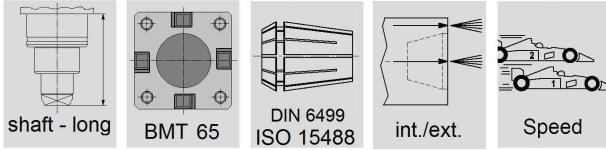

Schnittstelle Revolver <i>interface tool turret</i>		Drehmoment <i>torque</i>	Drehzahl <i>tool speed</i>	Leistung <i>output</i>	Übersetzung <i>gear ratio</i>	Wkzg.Aufnahme Spannbereich <i>tool holding fixture clamping range</i>	Ausführung <i>version</i>	Bestell-Nr. <i>order N°</i>	
Schaft / BG <i>shank / size</i>	Kupplung <i>coupling</i>								
d1 mm	l1 mm	M2 max Nm	n2 max 1/min	P max KW	i = n1 : n2	Spannbereich d <i>chucking capacity d</i>			
65	112.0	BMT BMT 65	70.0	12000	0.0	1.000	ISO 15488 - 32 - A 2-20	universal universal	178045

Erforderliche(r) Schlüssel zur Werkzeugspannung / *necessary key(s) for tool clamping*
(nicht im Lieferumfang enthalten / *not included in delivery*)

178629



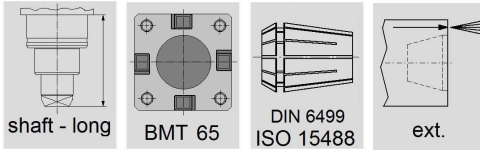

ext. 80 bar

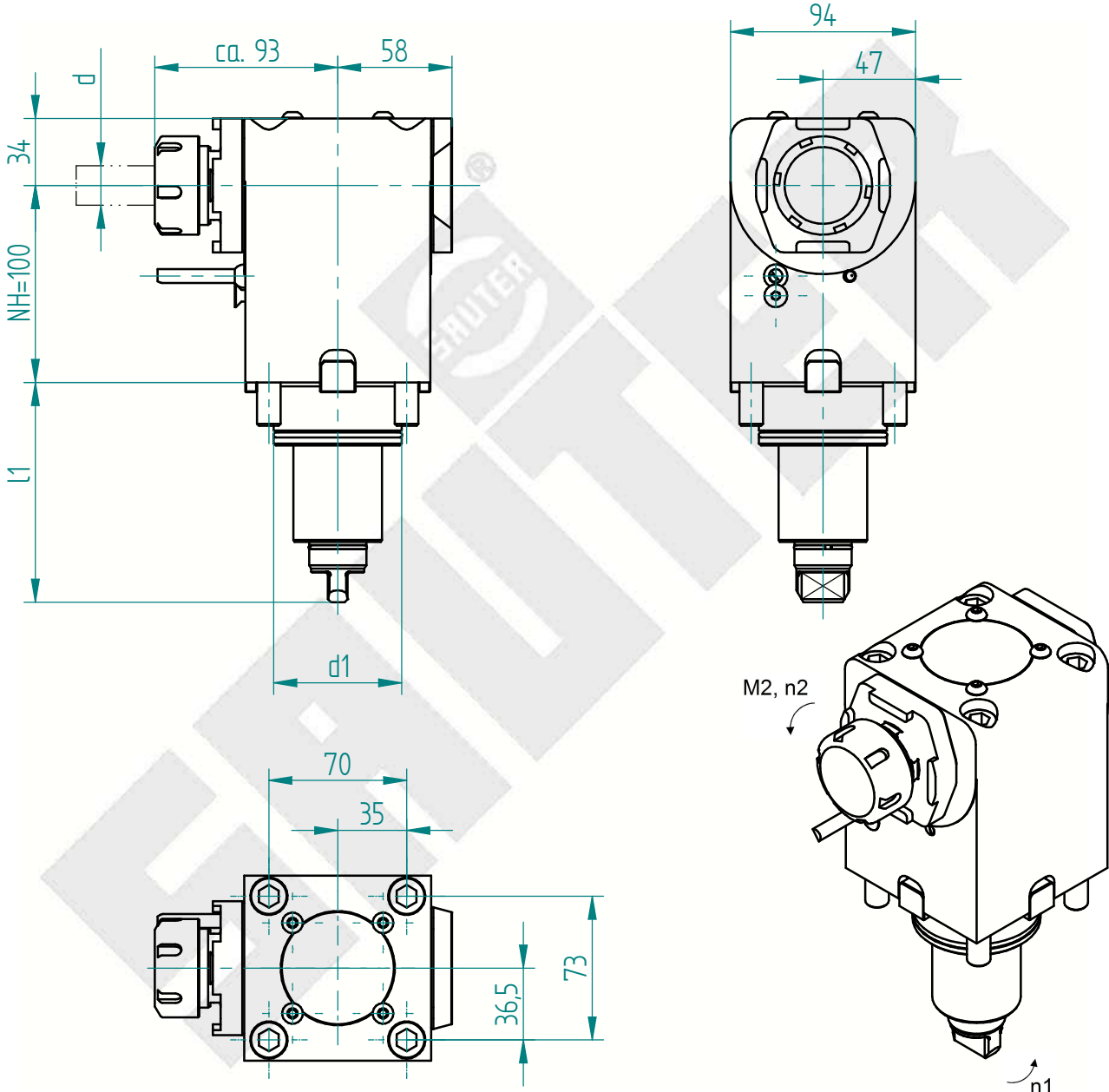

Änderungen vorbehalten. Subject to modification

Schnittstelle Revolver <i>interface tool turret</i>		Kupplung <i>coupling</i>	Drehmoment <i>torque</i>	Drehzahl <i>tool speed</i>	Leistung <i>output</i>	Übersetzung <i>gear ratio</i>	Wkzg.Aufnahme Spannbereich <i>tool holding fixture clamping range</i>	Ausführung <i>version</i>	Bestell-Nr. <i>order N°</i>
Schaft / BG <i>shank / size</i>									
d1 mm	l1 mm		M2 max Nm	n2 max 1/min	P max KW	i = n1: n2	Spannbereich d <i>chucking capacity d</i>		
65	112.0	BMT BMT 65	50.0	8000	0.0	1.000	ISO 15488 - 32 - A 2-20	universal universal	178048

Erforderliche(r) Schlüssel zur Werkzeugspannung / *necessary key(s) for tool clamping*
(nicht im Lieferumfang enthalten / *not included in delivery*) 178629

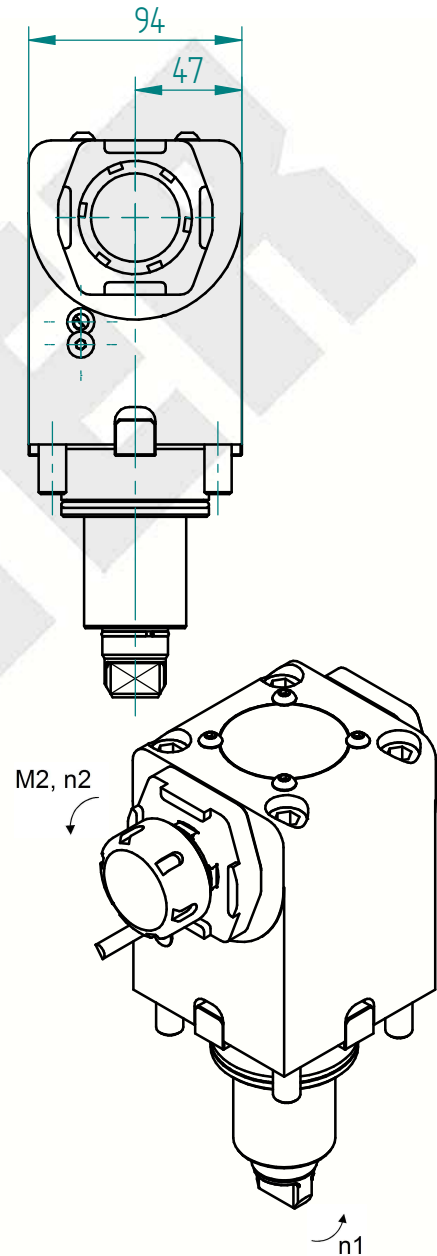
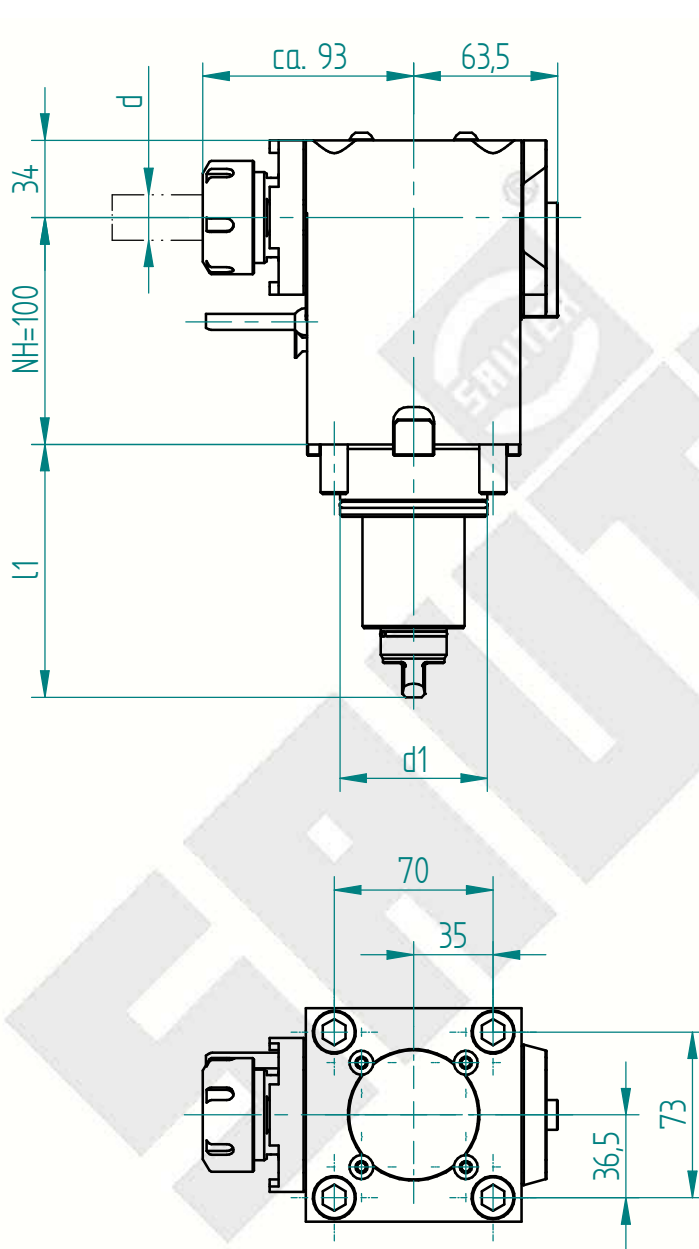
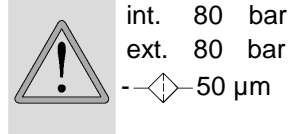
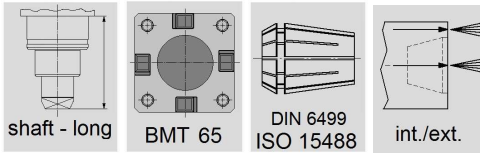

Schnittstelle Revolver <i>interface tool turret</i>		Kupplung <i>coupling</i>	Drehmoment <i>torque</i>	Drehzahl <i>tool speed</i>	Leistung <i>output</i>	Übersetzung <i>gear ratio</i>	Wkzg.Aufnahme Spannbereich <i>tool holding fixture clamping range</i>	Ausführung <i>version</i>	Bestell-Nr. <i>order N°</i>
Schaft / BG <i>shank / size</i>									
d1 mm	l1 mm		M2 max Nm	n2 max 1/min	P max KW	i = n1 : n2	Spannbereich d <i>chucking capacity d</i>		
65	112.0	BMT BMT 65	50.0	8000	0.0	1.000	ISO 15488 - 32 - A 2-20	universal universal	178051

Erforderliche(r) Schlüssel zur Werkzeugspannung / *necessary key(s) for tool clamping*
(nicht im Lieferumfang enthalten / *not included in delivery*)

178629



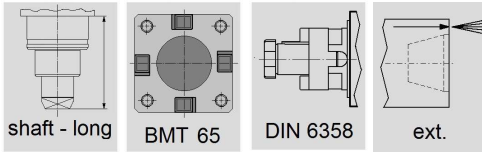

ext. 80 bar

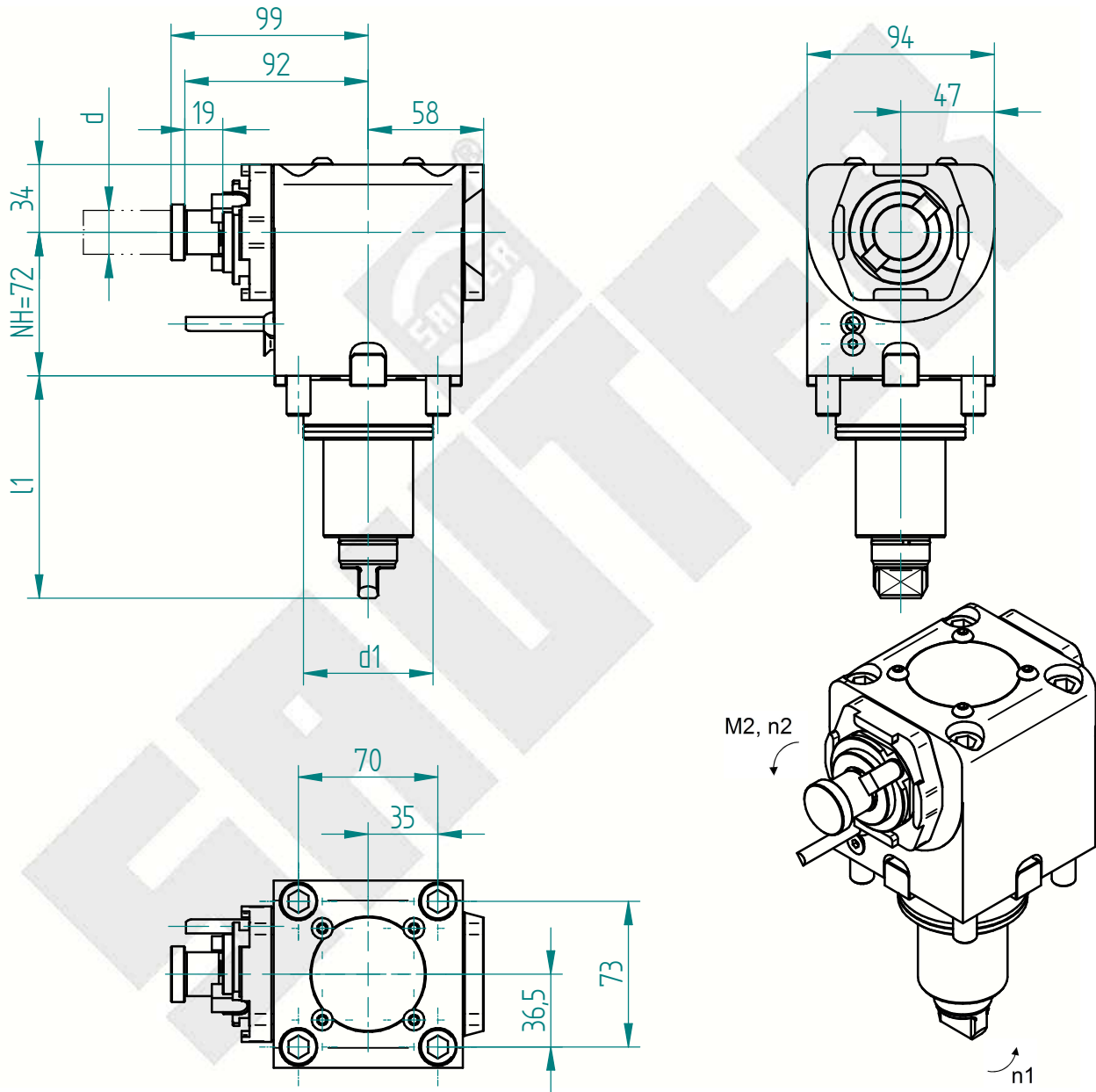

Änderungen vorbehalten. Subject to modification

Schnittstelle Revolver interface tool turret		Drehmoment torque	Drehzahl tool speed	Leistung output	Übersetzung gear ratio	Wkzg.Aufnahme Spannbereich tool holding fixture clamping range	Ausführung version	Bestell-Nr. order N°	
Schaft / BG shank / size	Kupplung coupling								
d1 mm	l1 mm	M2 max Nm	n2 max 1/min	P max KW	i = n1: n2	Spannbereich d chucking capacity d			
65	112.0	BMT BMT 65	50.0	6000	0.0	1.000	DIN 6358 - 22 22	universal universal	178053

Erforderliche(r) Schlüssel zur Werkzeugspannung / necessary key(s) for tool clamping
(nicht im Lieferumfang enthalten / not included in delivery)

178629



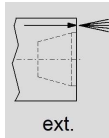
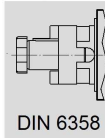
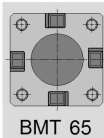
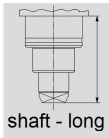

ext. 80 bar

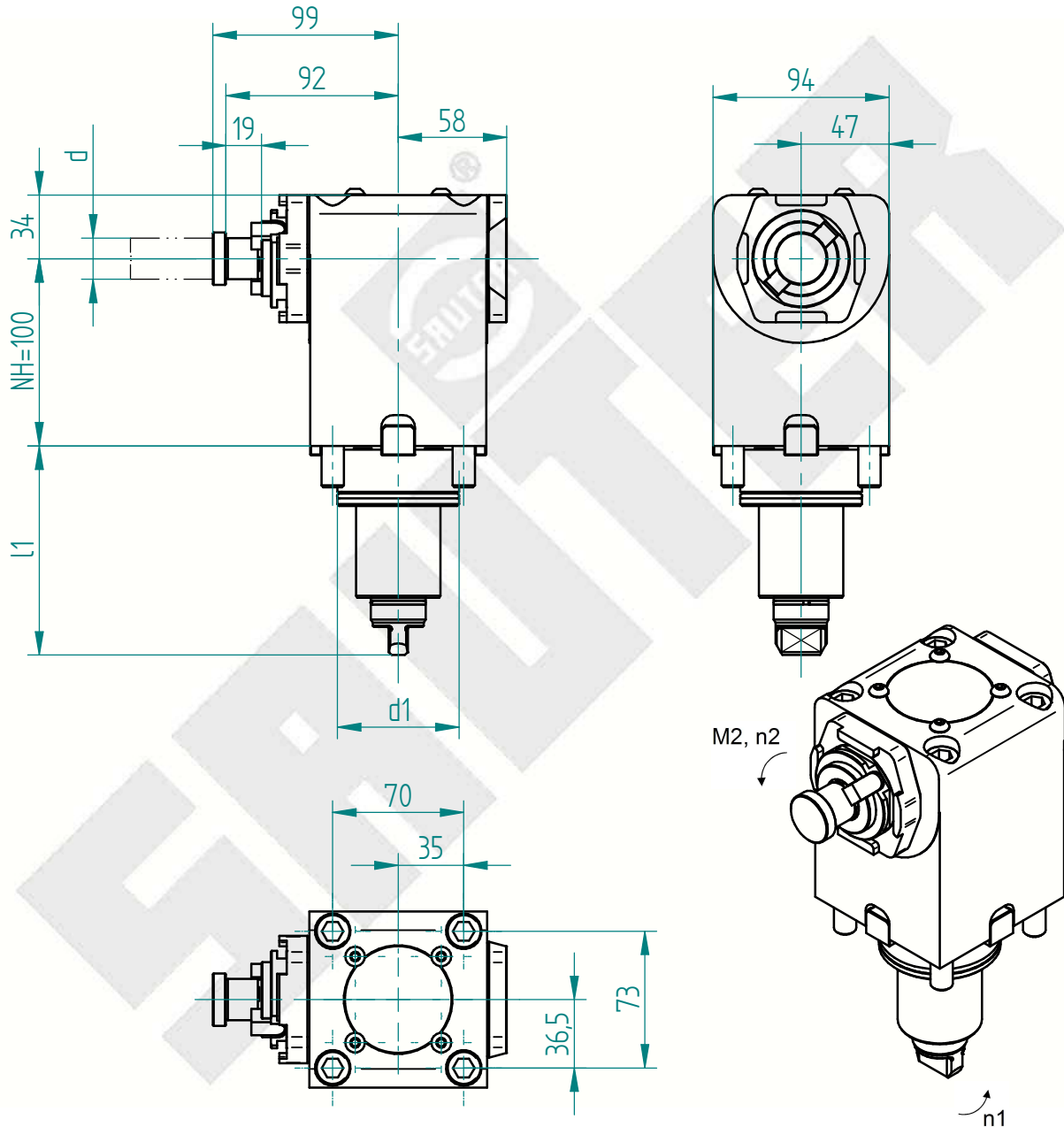

Änderungen vorbehalten. Subject to modification

Schnittstelle Revolver interface tool turret		Drehmoment torque	Drehzahl tool speed	Leistung output	Übersetzung gear ratio	Wkzg.Aufnahme Spannbereich tool holding fixture clamping range	Ausführung version	Bestell-Nr. order N°	
Schaft / BG shank / size	Kupplung coupling								
d1 mm	l1 mm	M2 max Nm	n2 max 1/min	P max KW	i = n1 : n2	Spannbereich d chucking capacity d			
65	81.0	BMT BMT 65	50.0	6000	0.0	1.000	DIN 6358 - 22 22	universal universal	178055

Erforderliche(r) Schlüssel zur Werkzeugspannung / necessary key(s) for tool clamping
(nicht im Lieferumfang enthalten / not included in delivery)

178629



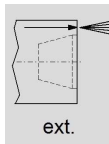
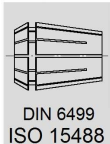
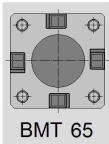
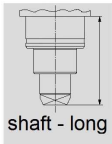

ext. 80 bar

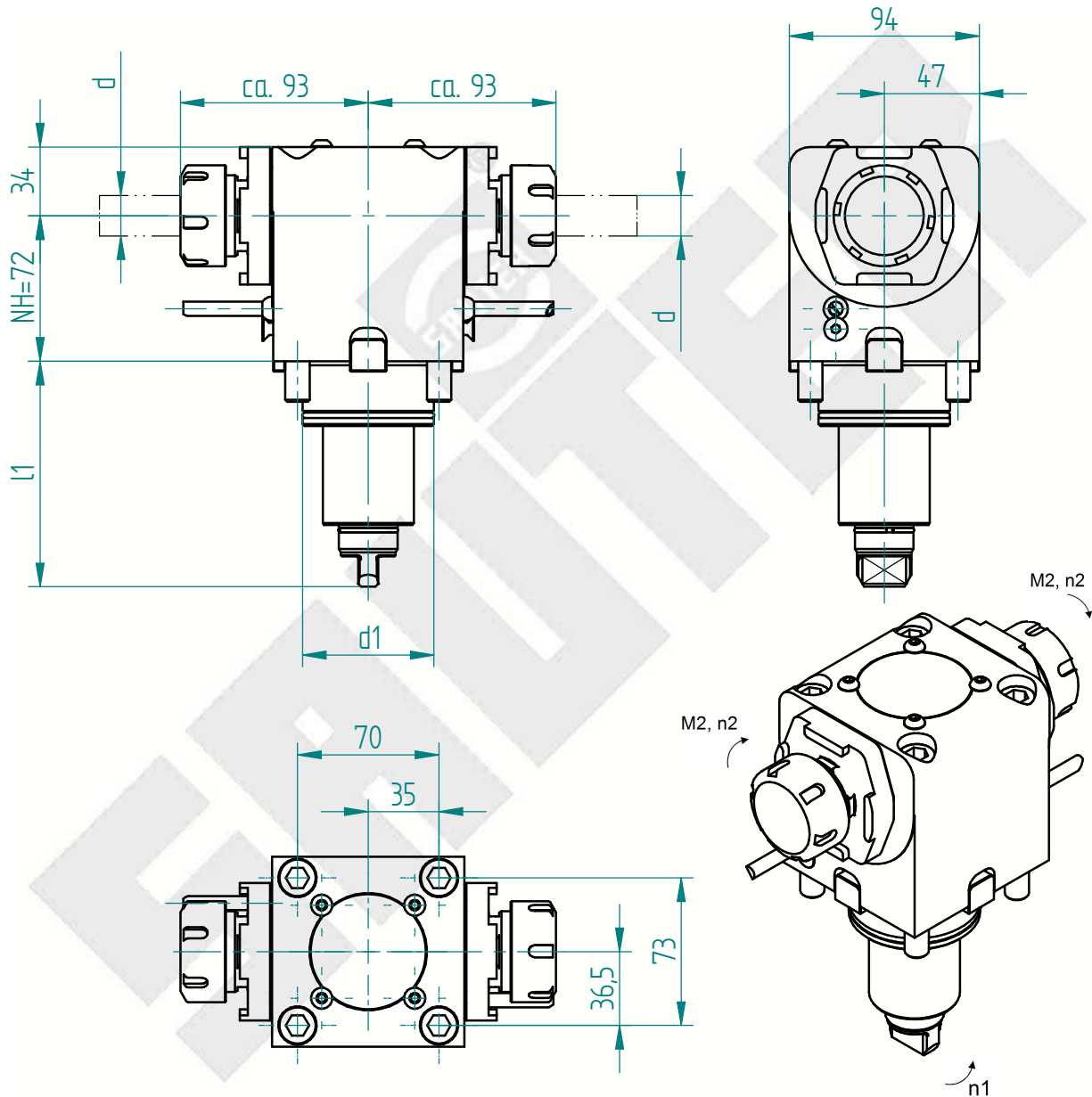

Änderungen vorbehalten. Subject to modification

Schnittstelle Revolver interface tool turret		Kupplung coupling	Drehmoment torque	Drehzahl tool speed	Leistung output	Übersetzung gear ratio	Wkzg.Aufnahme Spannbereich tool holding fixture clamping range	Ausführung version	Bestell-Nr. order N°
Schaft / BG shank / size									
d1 mm	l1 mm		M2 max Nm	n2 max 1/min	P max KW	i = n1: n2	Spannbereich d chucking capacity d		
65	112.0	BMT BMT 65	50.0	8000	0.0	1.000	ISO 15488 - 32 - A 2-20	universal universal	178057

Erforderliche(r) Schlüssel zur Werkzeugspannung / necessary key(s) for tool clamping
(nicht im Lieferumfang enthalten / not included in delivery)

178629



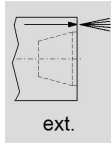
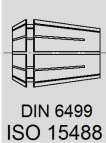
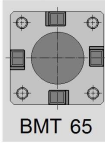
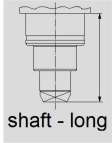

ext. 80 bar

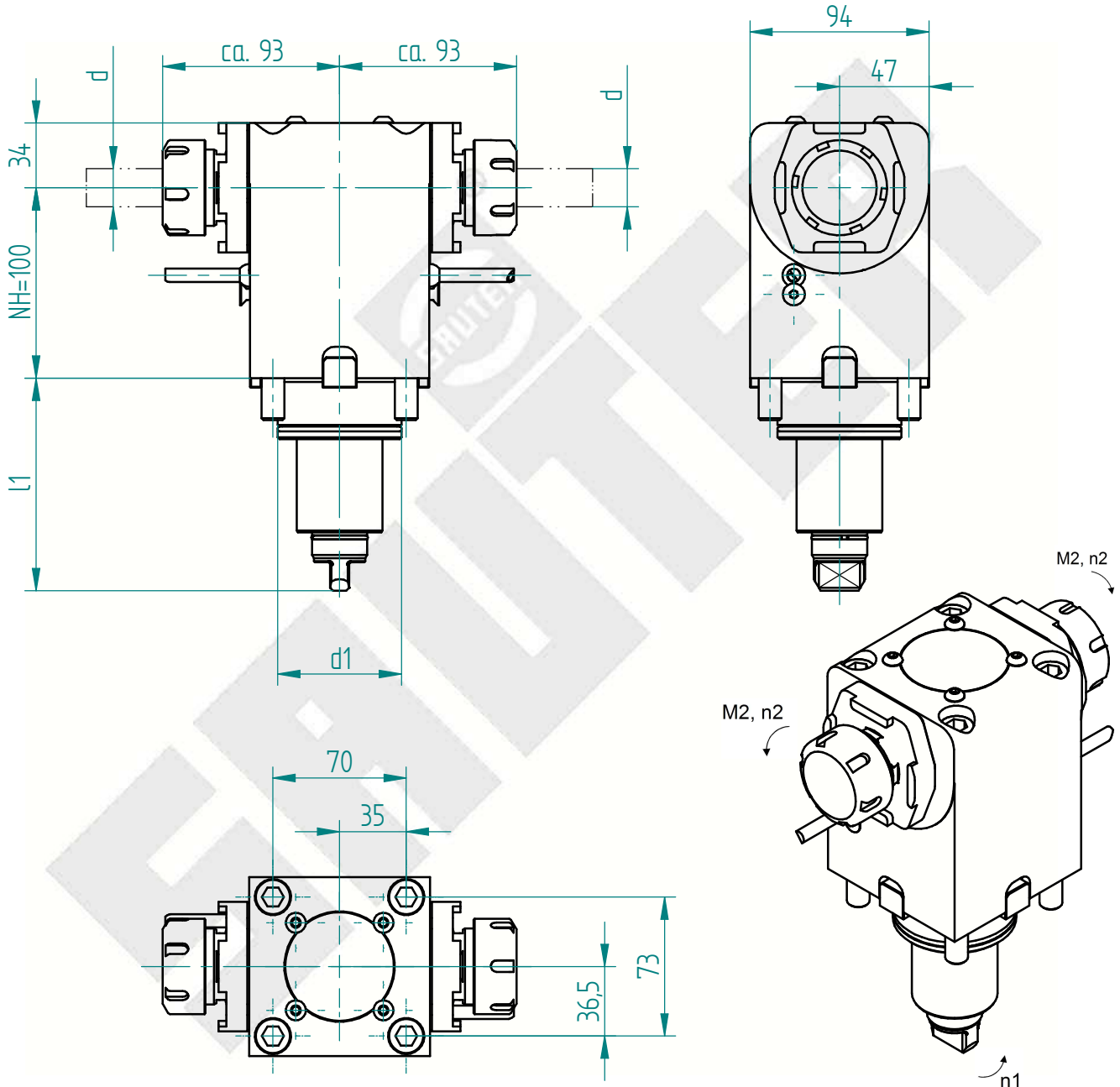

Änderungen vorbehalten. Subject to modification

Schnittstelle Revolver interface tool turret		Drehmoment torque	Drehzahl tool speed	Leistung output	Übersetzung gear ratio	Wkzg.Aufnahme Spannbereich tool holding fixture clamping range	Ausführung version	Bestell-Nr. order N°	
Schaft / BG shank / size	Kupplung coupling								
d1 mm	l1 mm	M2 max Nm	n2 max 1/min	P max KW	i = n1: n2	Spannbereich d chucking capacity d			
65	112.0	BMT BMT 65	50.0	8000	0.0	1.000	ISO 15488 - 32 - A 2-20	universal universal	178060

Erforderliche(r) Schlüssel zur Werkzeugspannung / necessary key(s) for tool clamping
(nicht im Lieferumfang enthalten / not included in delivery) 178629

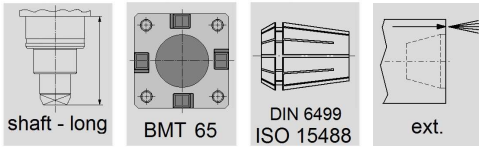

ext. 80 bar

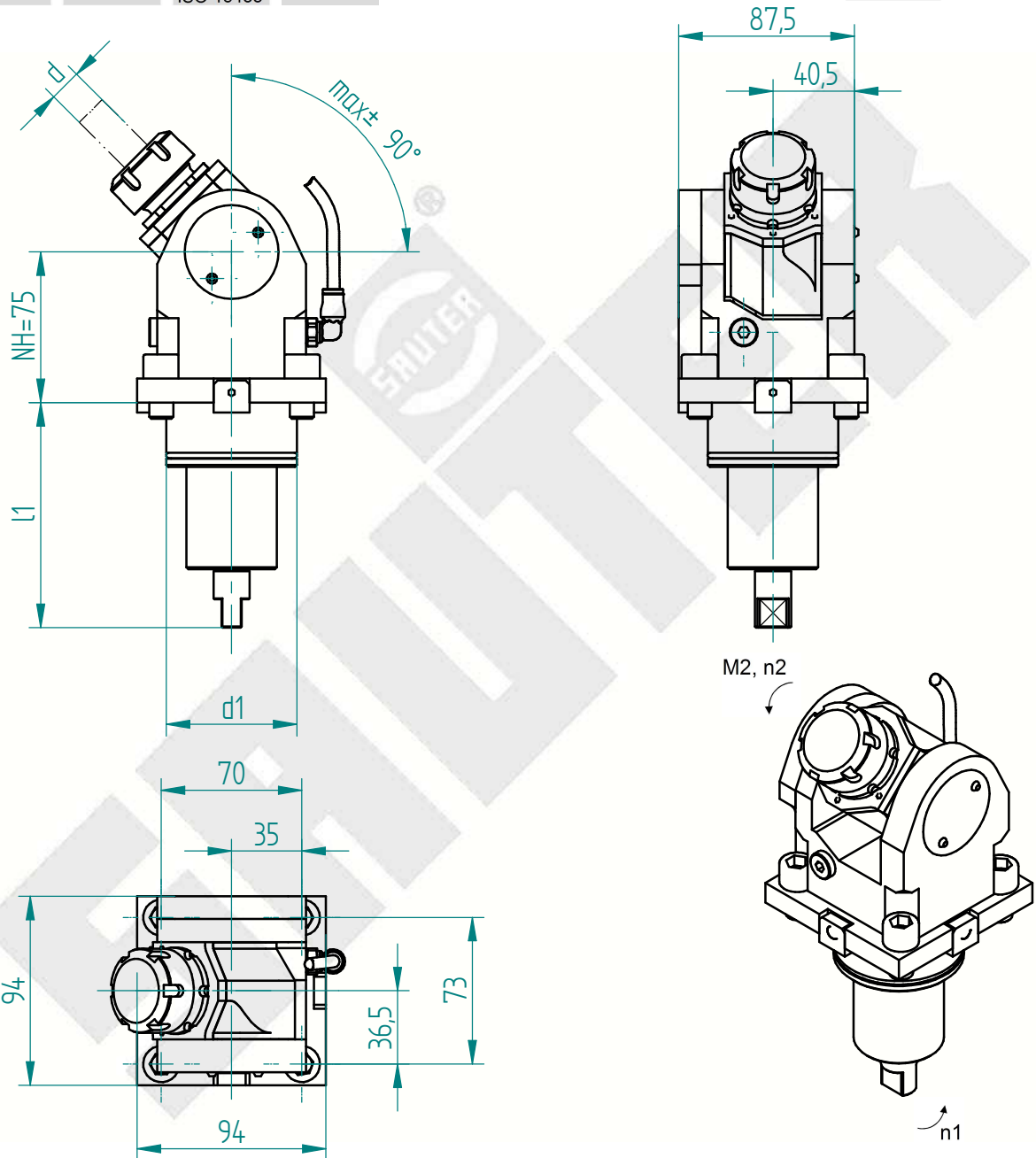

Änderungen vorbehalten. Subject to modification

Schnittstelle Revolver <i>interface tool turret</i>		Kupplung <i>coupling</i>	Drehmoment <i>torque</i>	Drehzahl <i>tool speed</i>	Leistung <i>output</i>	Übersetzung <i>gear ratio</i>	Wkzg.Aufnahme Spannbereich <i>tool holding fixture clamping range</i>	Ausführung <i>version</i>	Bestell-Nr. <i>order N°</i>
Schaft / BG <i>shank / size</i>									
d1 mm	l1 mm		M2 max Nm	n2 max 1/min	P max KW	i = n1 : n2	Spannbereich d <i>chucking capacity d</i>		
65	112.0	BMT BMT 65	25.0	6000	4.0	1.000	ISO 15488 - 25 - A 1-16	universal universal	178062

Erforderliche(r) Schlüssel zur Werkzeugspannung / *necessary key(s) for tool clamping*
(nicht im Lieferumfang enthalten / *not included in delivery*)

178651+178652



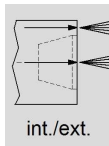
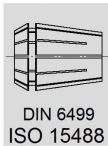
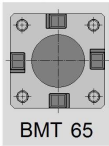
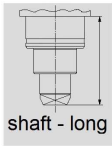

int. 80 bar
ext. 80 bar
- 50 µm

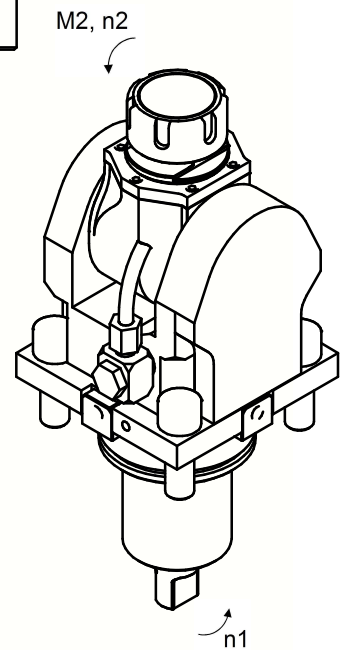
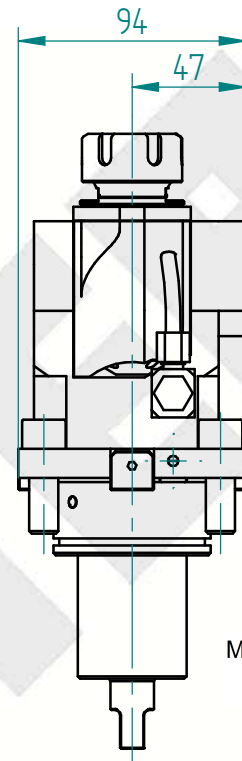
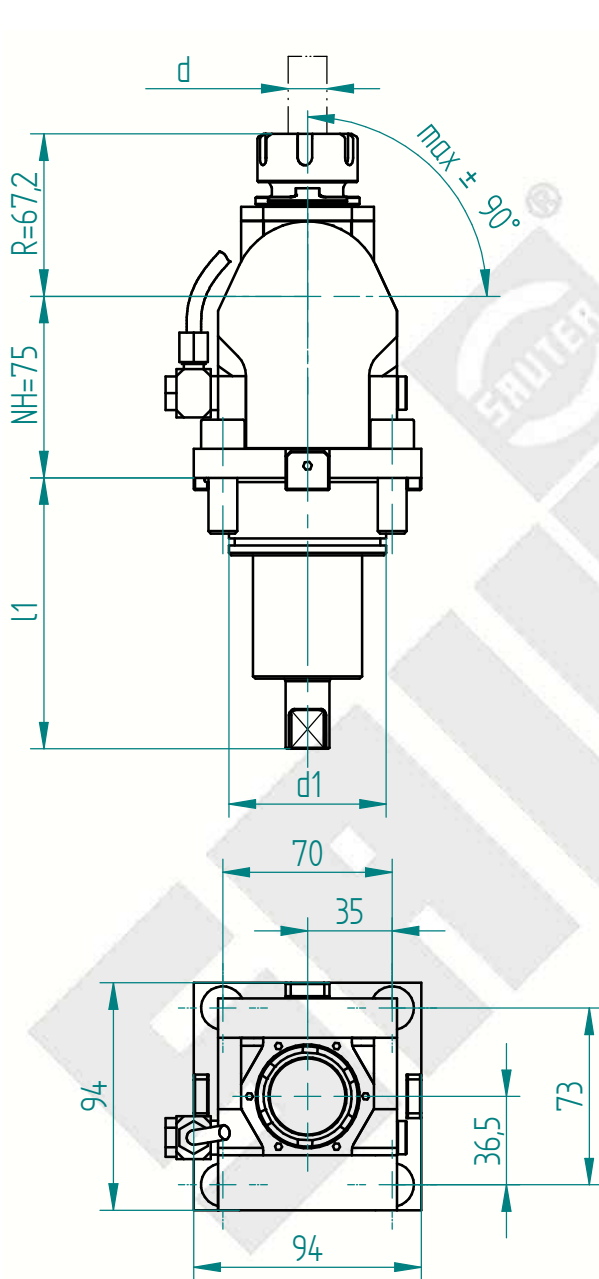

Schnittstelle Revolver <i>interface tool turret</i>		Drehmoment <i>torque</i>	Drehzahl <i>tool speed</i>	Leistung <i>output</i>	Übersetzung <i>gear ratio</i>	Wkzg.Aufnahme Spannbereich <i>tool holding fixture clamping range</i>	Ausführung <i>version</i>	Bestell-Nr. <i>order N°</i>	
Schaft / BG <i>shank / size</i>	Kupplung <i>coupling</i>								
d1 mm	l1 mm	M2 max Nm	n2 max 1/min	P max KW	i = n1 : n2	Spannbereich d <i>chucking capacity d</i>			
65	112.0	BMT BMT 65	25.0	6000	4.0	1.000	ISO 15488 - 25 - A 1-16	universal universal	178071

Erforderliche(r) Schlüssel zur Werkzeugspannung / *necessary key(s) for tool clamping*
(nicht im Lieferumfang enthalten / *not included in delivery*)

178651+178652



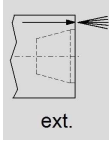
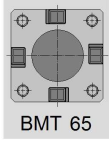

int. bar
ext. 80 bar

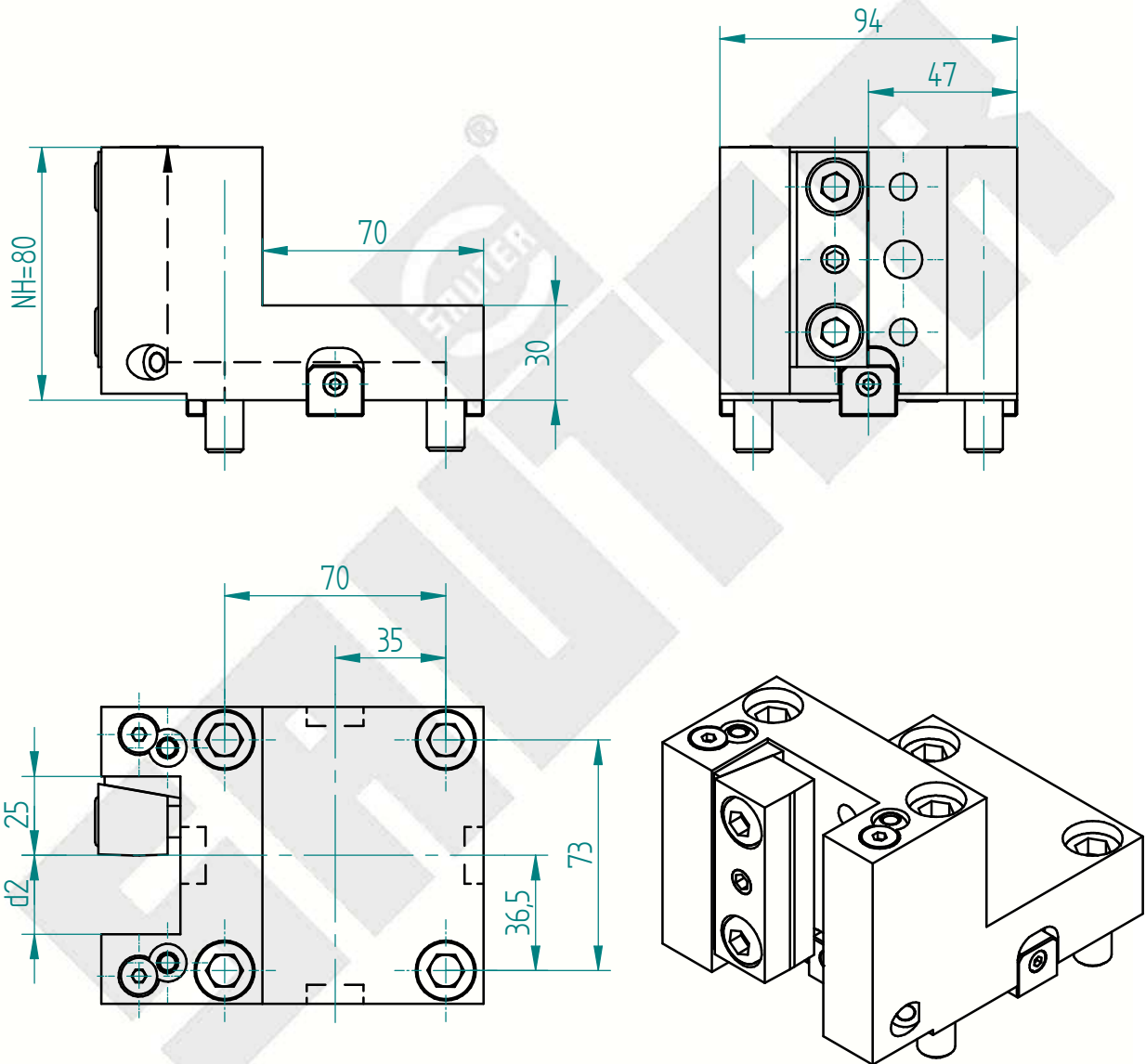

Schaft / BG shank / size		Werkzeugaufnahme tool location	Ausführung version	Bestell-Nr. order N°
d1 mm	l1 mm	Aufnahme d2 location d2		
65.0		Werkzeughalter mit Vierkantaufnahme-25	gerade straight	178558

Erforderliche(r) Schlüssel zur Werkzeugspannung / necessary key(s) for tool clamping
(nicht im Lieferumfang enthalten / not included in delivery)

Inbusschlüssel / Allen head wrench



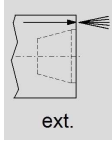
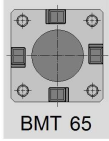

int. bar
ext. 80 bar

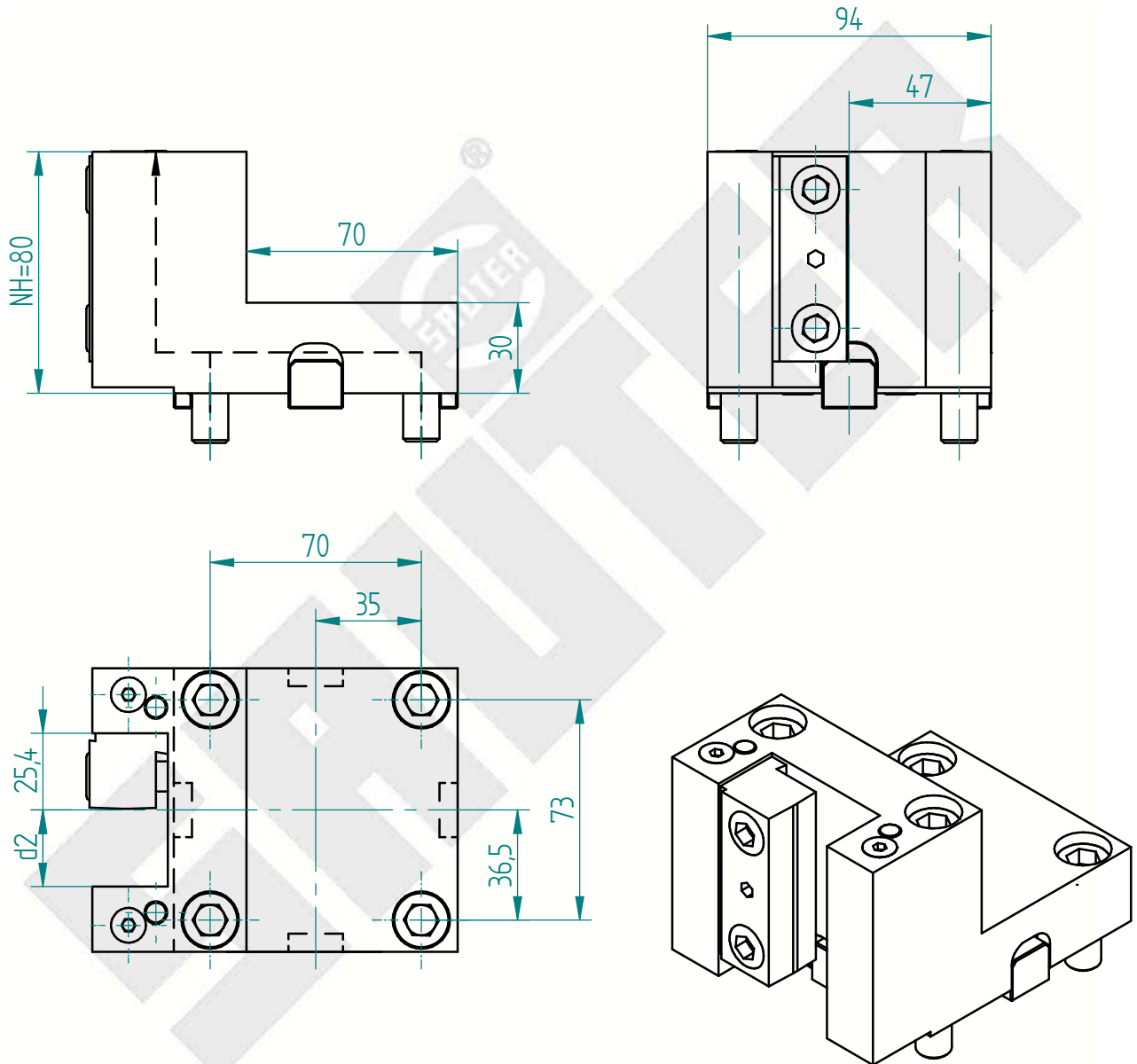

Schaft / BG shank / size		Werkzeugaufnahme tool location	Ausführung version	Bestell-Nr. order N°
d1 mm	l1 mm	Aufnahme d2 location d2		
65.0		Werkzeughalter mit Vierkantaufn.-1"	gerade straight	178559

Erforderliche(r) Schlüssel zur Werkzeugspannung / necessary key(s) for tool clamping
(nicht im Lieferumfang enthalten / not included in delivery)

Inbusschlüssel / Allen head wrench



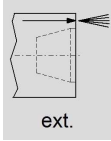
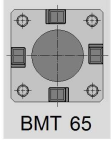

int. bar
ext. 80 bar

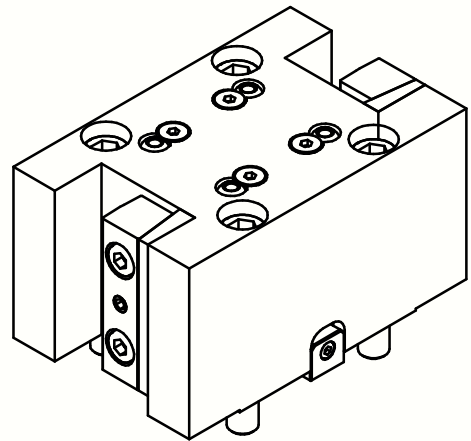
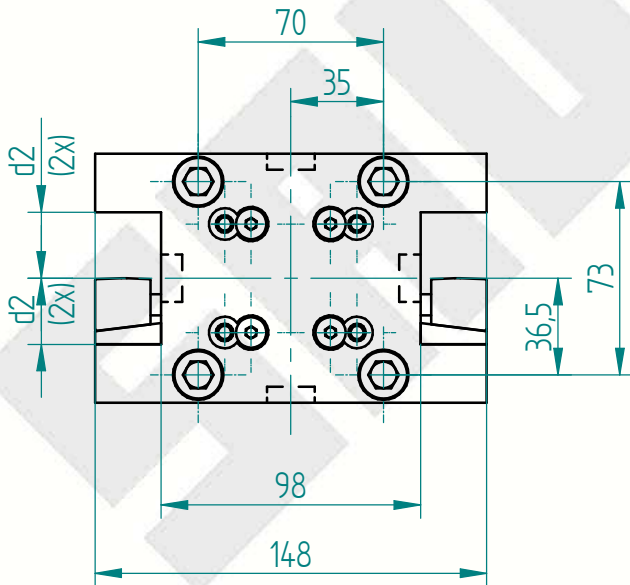
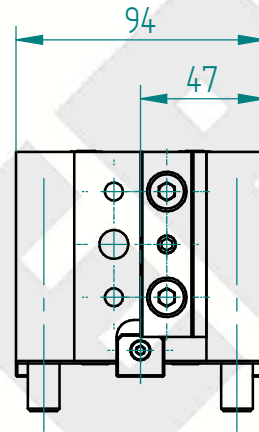
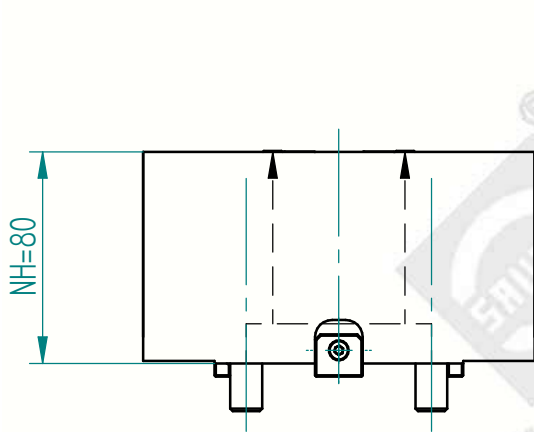

Schaft / BG shank / size		Werkzeugaufnahme tool location	Ausführung version	Bestell-Nr. order N°
d1 mm	l1 mm	Aufnahme d2 location d2		
65.0		Werkzeughalter mit Vierkantaufnahme-25	gerade straight	178560

Erforderliche(r) Schlüssel zur Werkzeugspannung / necessary key(s) for tool clamping
(nicht im Lieferumfang enthalten / not included in delivery)

Inbusschlüssel / Allen head wrench



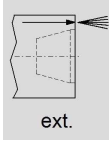
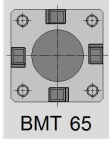

int. bar
ext. 80 bar

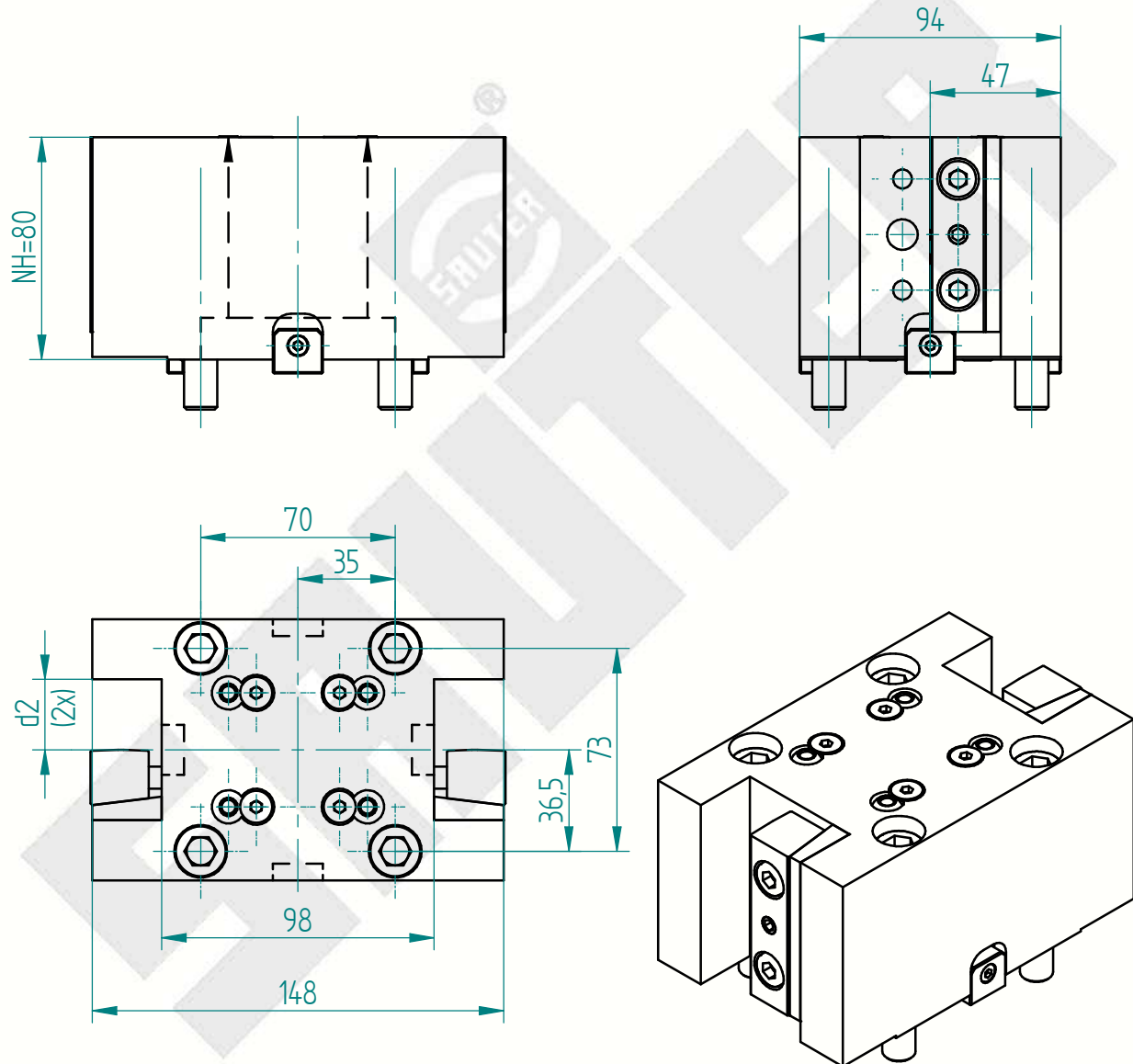

Schaft / BG shank / size		Werkzeugaufnahme tool location	Ausführung version	Bestell-Nr. order N°
d1 mm	l1 mm	Aufnahme d2 location d2		
65.0		Werkzeughalter + Vierkantaufnahme-1"	gerade straight	178561

Erforderliche(r) Schlüssel zur Werkzeugspannung / necessary key(s) for tool clamping
(nicht im Lieferumfang enthalten / not included in delivery)

Inbusschlüssel / Allen head wrench



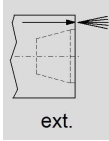
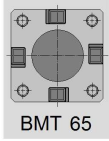

int. bar
ext. 80 bar

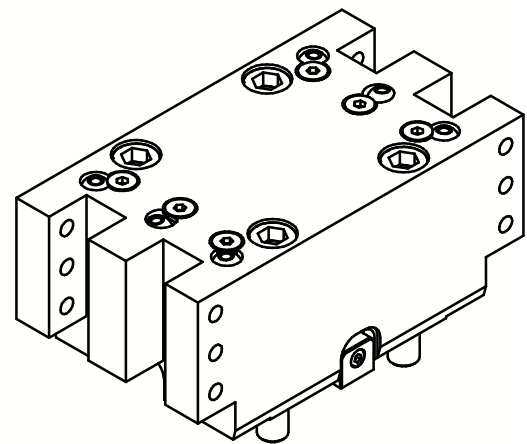
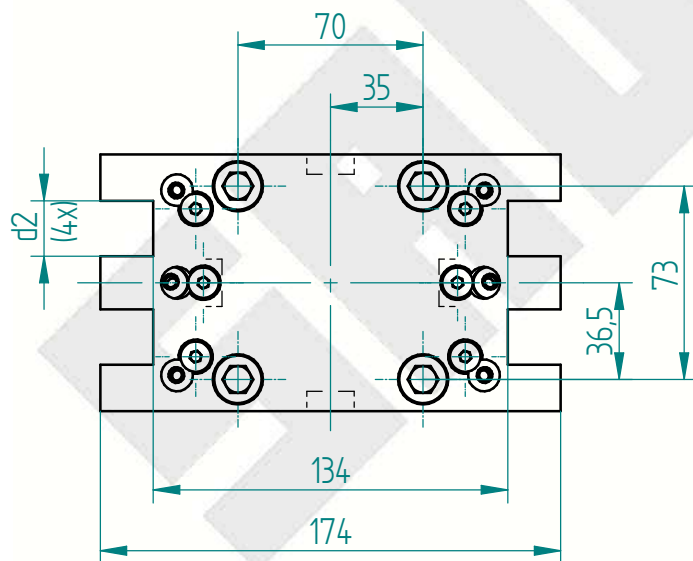
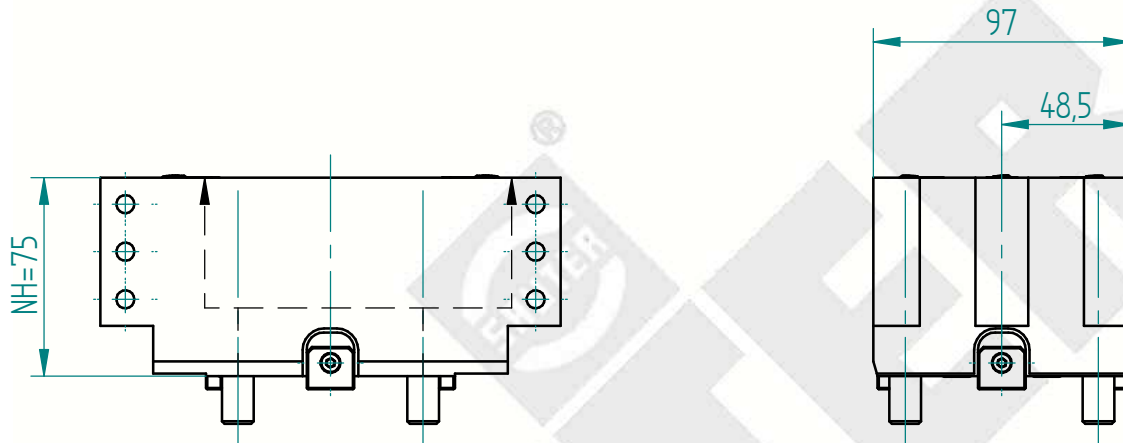

Schaft / BG shank / size		Werkzeugaufnahme tool location	Ausführung version	Bestell-Nr. order N°
d1 mm	l1 mm	Aufnahme d2 location d2		
65.0		Werkzeughalter mit Vierkantaufnahme-20	gerade straight	178454

Erforderliche(r) Schlüssel zur Werkzeugspannung / necessary key(s) for tool clamping
(nicht im Lieferumfang enthalten / not included in delivery)

Inbusschlüssel / Allen head wrench



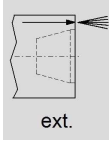
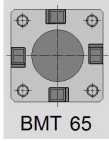

int. bar
ext. 80 bar

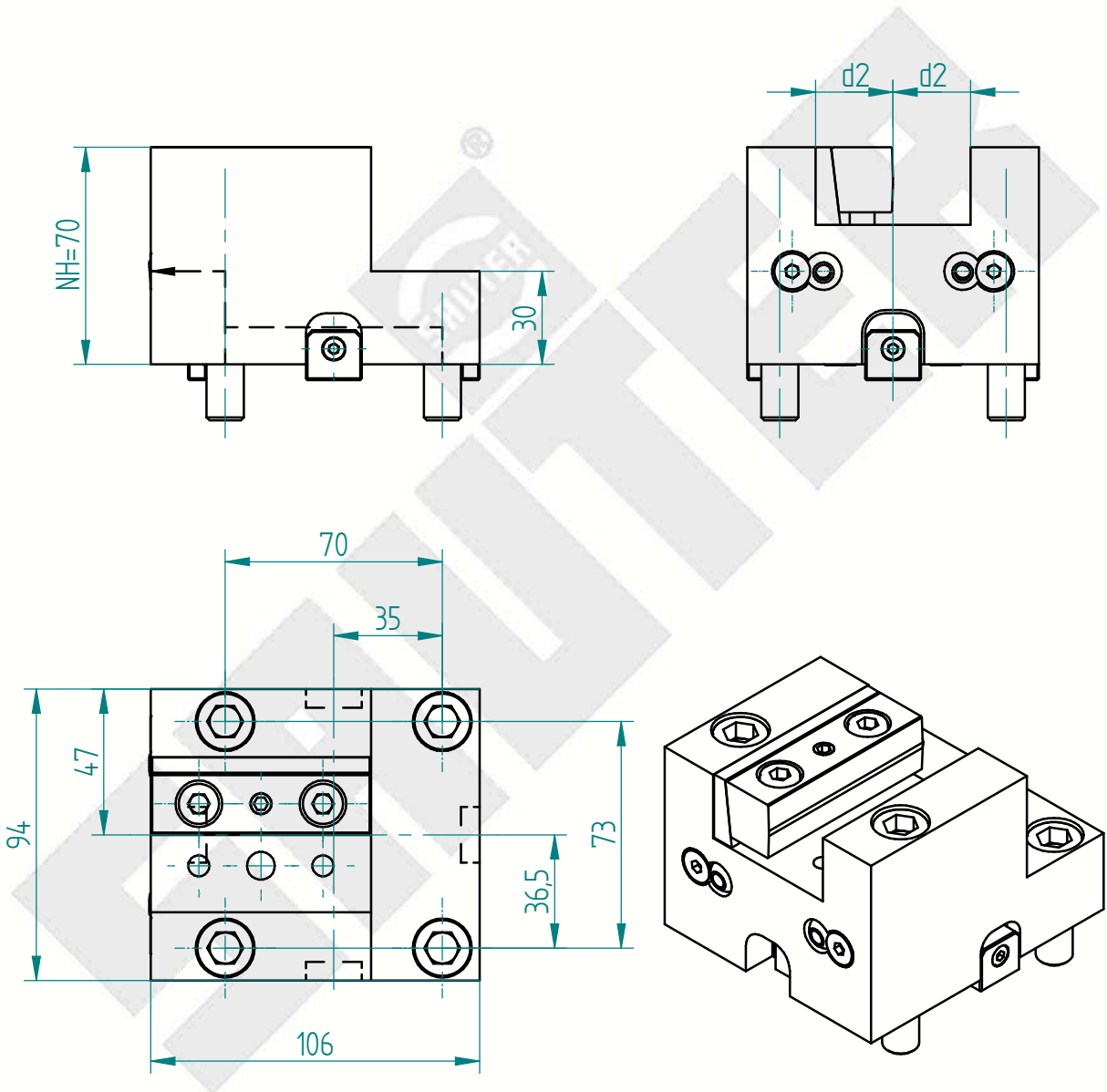

Schaft / BG shank / size		Werkzeugaufnahme tool location	Ausführung version	Bestell-Nr. order N°
d1 mm	l1 mm	Aufnahme d2 location d2		
65.0		Werkzeughalter mit Vierkantaufnahme-25	gerade straight	178457

Erforderliche(r) Schlüssel zur Werkzeugspannung / necessary key(s) for tool clamping
(nicht im Lieferumfang enthalten / not included in delivery)

Inbusschlüssel / Allen head wrench



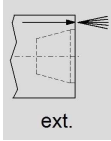
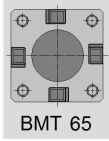

int. bar
ext. 80 bar

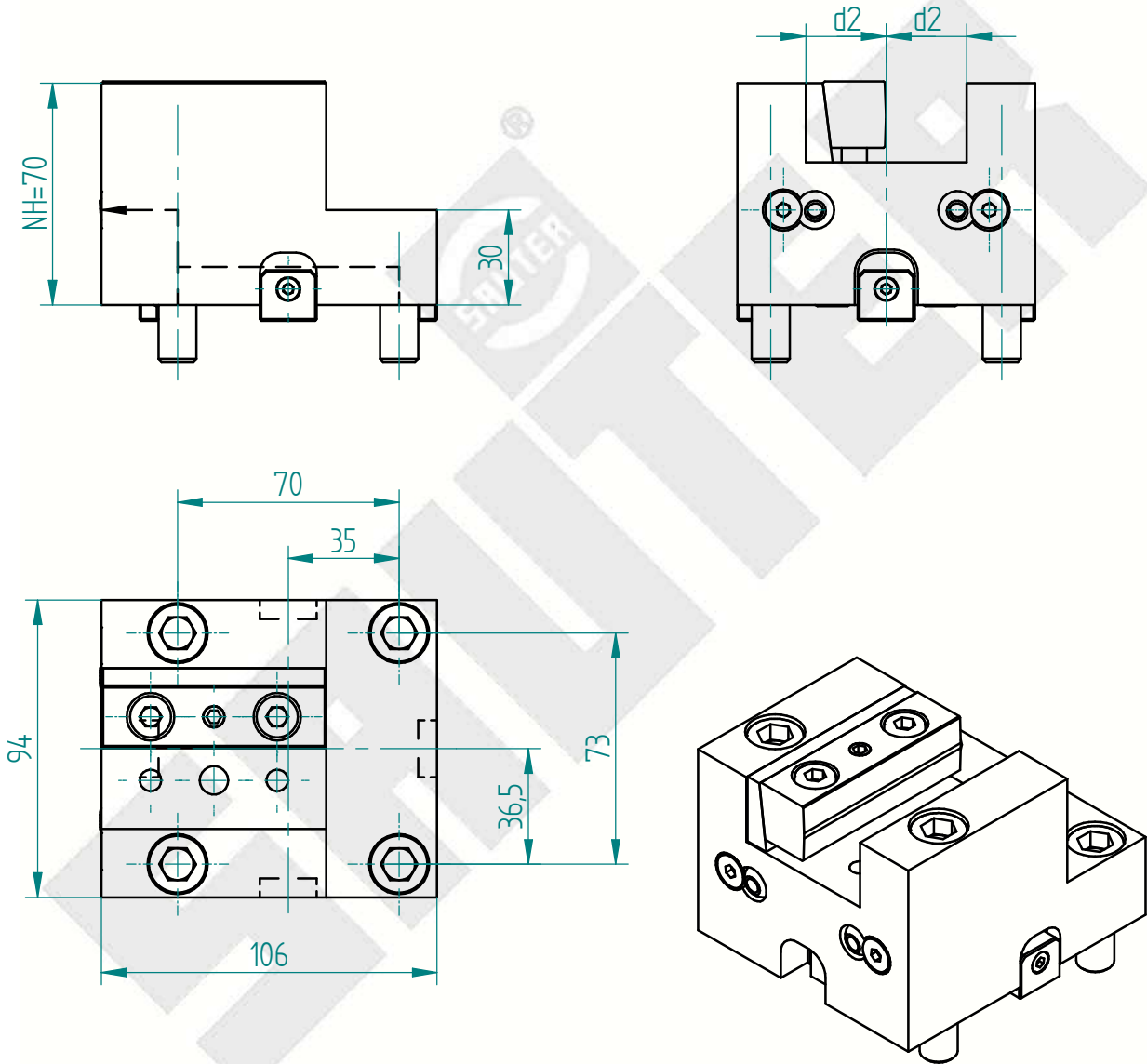

Schaft / BG shank / size		Werkzeugaufnahme tool location	Ausführung version	Bestell-Nr. order N°
d1 mm	l1 mm	Aufnahme d2 location d2		
65.0		Werkzeughalter + Vierkantaufnahme-1"	gerade straight	178562

Erforderliche(r) Schlüssel zur Werkzeugspannung / necessary key(s) for tool clamping
(nicht im Lieferumfang enthalten / not included in delivery)

Inbusschlüssel / Allen head wrench



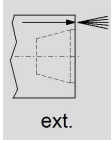
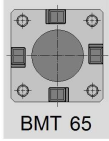

int. bar
ext. 80 bar

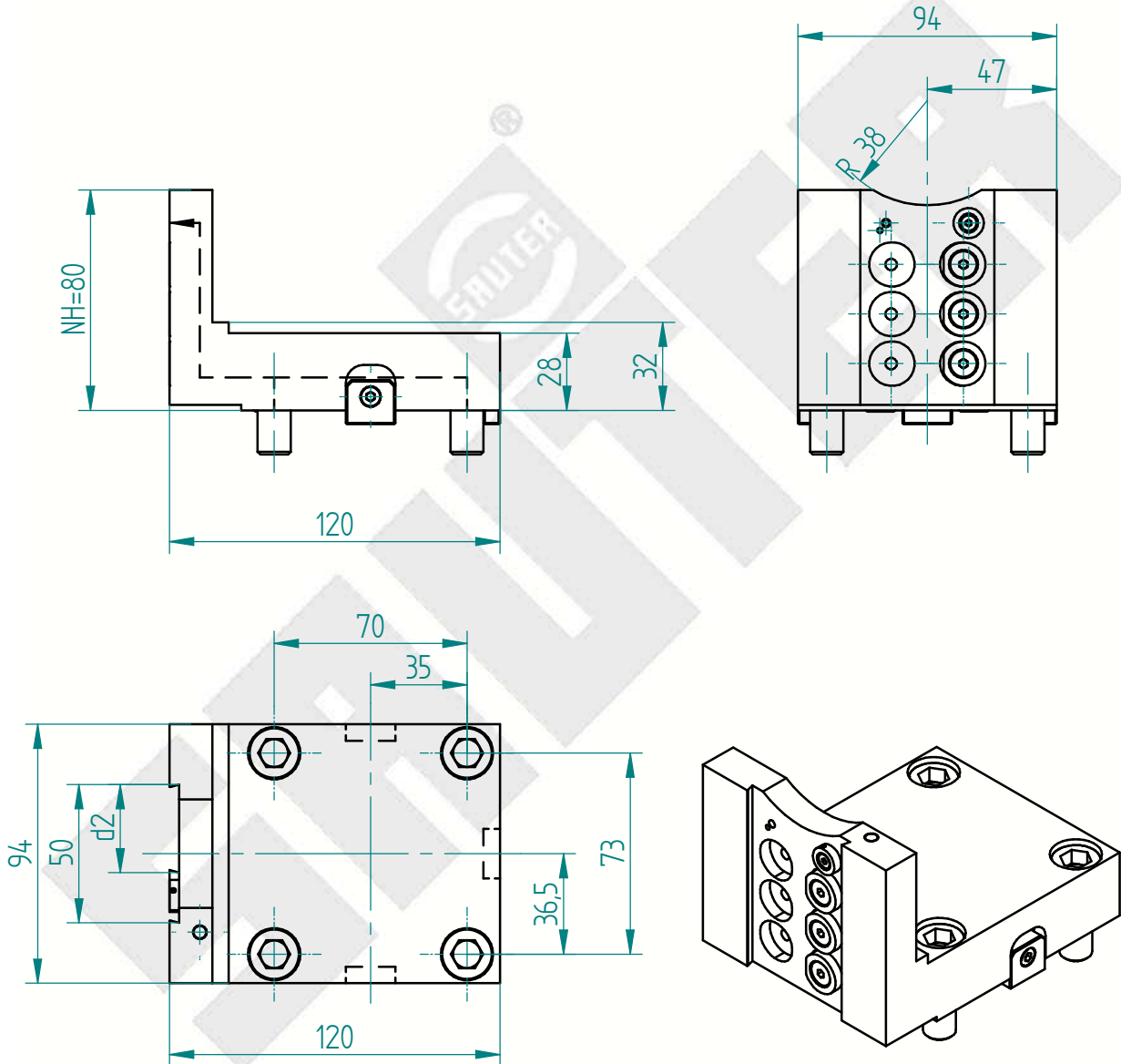

Schaft / BG shank / size		Werkzeugaufnahme tool location	Ausführung version	Bestell-Nr. order N°
d1 mm	l1 mm	Aufnahme d2 location d2		
65.0		Abstechhalter fuer Stechklingen-32	gerade straight	178459

Erforderliche(r) Schlüssel zur Werkzeugspannung / necessary key(s) for tool clamping
(nicht im Lieferumfang enthalten / not included in delivery)

Inbusschlüssel / Allen head wrench



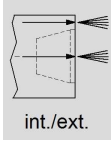
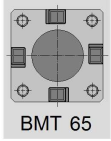

int. 80 bar
ext. 80 bar

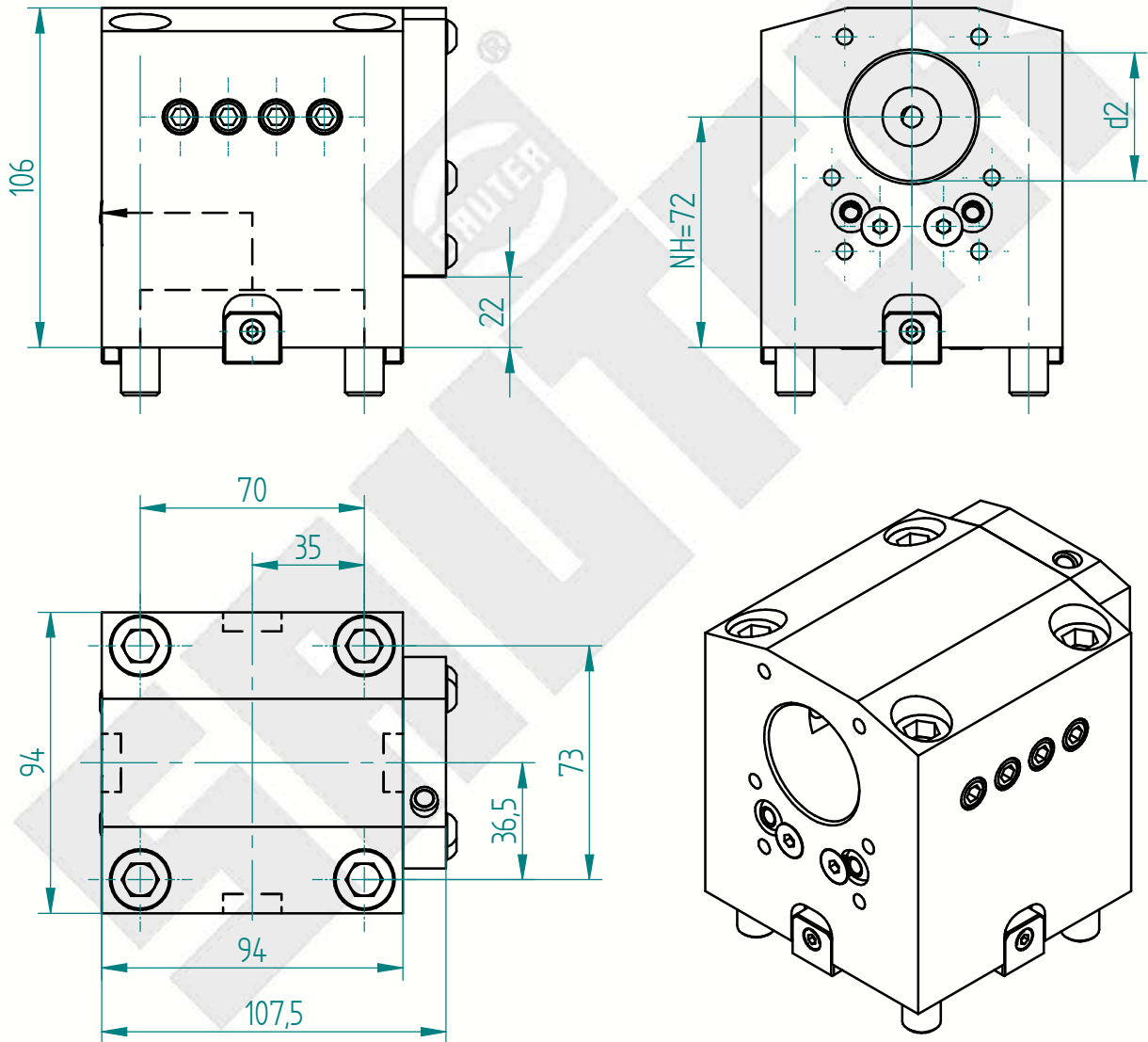

Schaft / BG shank / size		Werkzeugaufnahme tool location	Ausführung version	Bestell-Nr. order N°
d1 mm	l1 mm	Aufnahme d2 location d2		
65.0		Bohrstangenhalter mit Gewindestift-40	gerade straight	178461

Erforderliche(r) Schlüssel zur Werkzeugspannung / necessary key(s) for tool clamping
(nicht im Lieferumfang enthalten / not included in delivery)

Inbusschlüssel / Allen head wrench



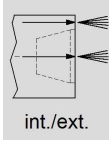
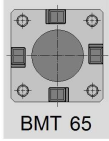

int. 80 bar
ext. 80 bar

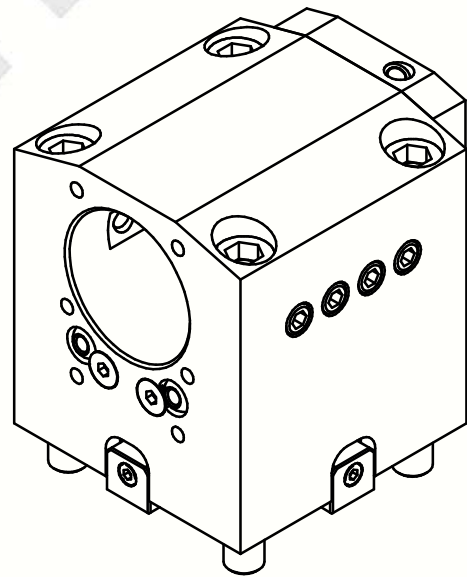
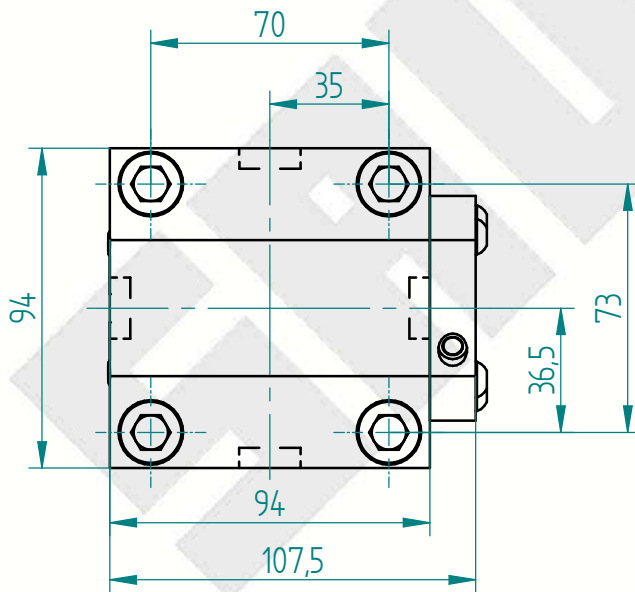
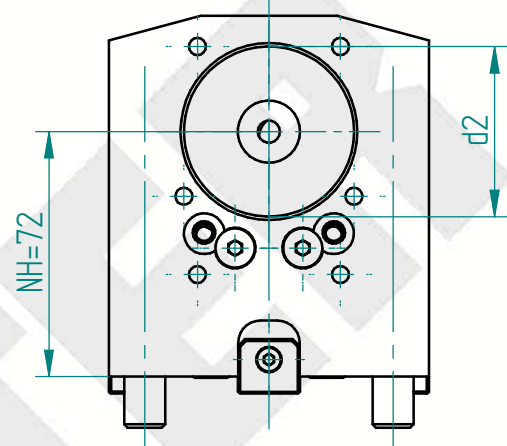
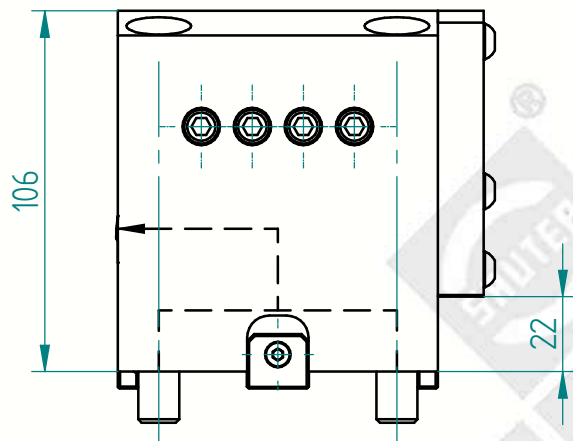

Schaft / BG shank / size		Werkzeugaufnahme tool location	Ausführung version	Bestell-Nr. order N°
d1 mm	l1 mm	Aufnahme d2 location d2		
65.0		Bohrstangenhalter mit Gewindestift-50	gerade straight	178563

Erforderliche(r) Schlüssel zur Werkzeugspannung / necessary key(s) for tool clamping
(nicht im Lieferumfang enthalten / not included in delivery)

Inbusschlüssel / Allen head wrench



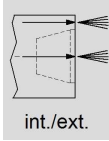
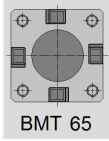

int. 80 bar
ext. 80 bar

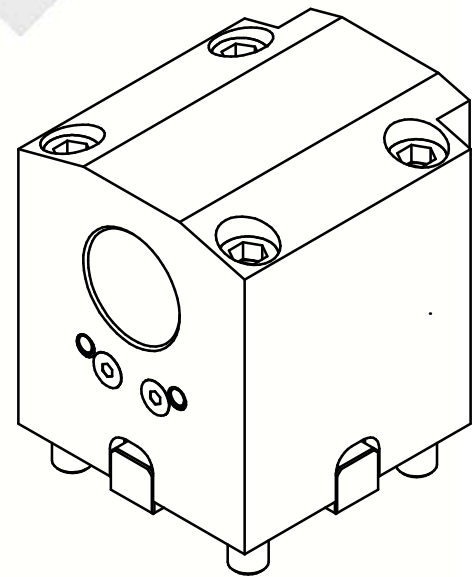
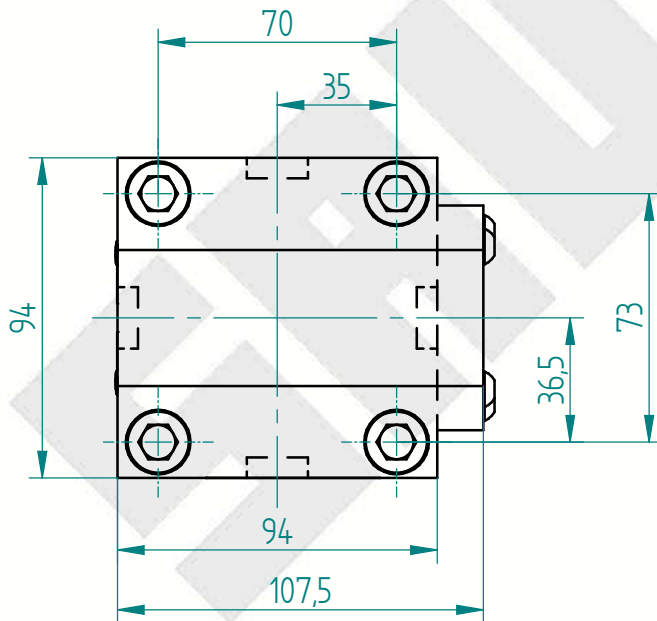
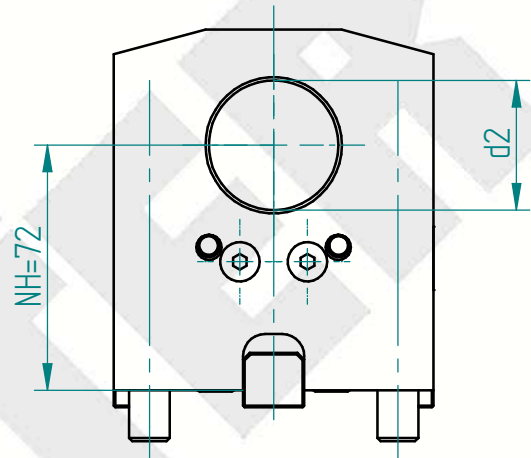
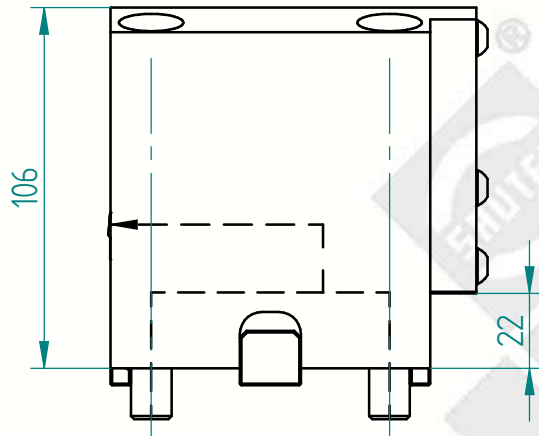

Schaft / BG shank / size		Werkzeugaufnahme tool location	Ausführung version	Bestell-Nr. order N°
d1 mm	l1 mm	Aufnahme d2 location d2		
65.0		Bohrstangenhalter mit Gewindest.-1.5"	gerade straight	178564

Erforderliche(r) Schlüssel zur Werkzeugspannung / necessary key(s) for tool clamping
(nicht im Lieferumfang enthalten / not included in delivery)

Inbusschlüssel / Allen head wrench



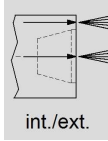
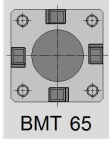

int. 80 bar
ext. 80 bar

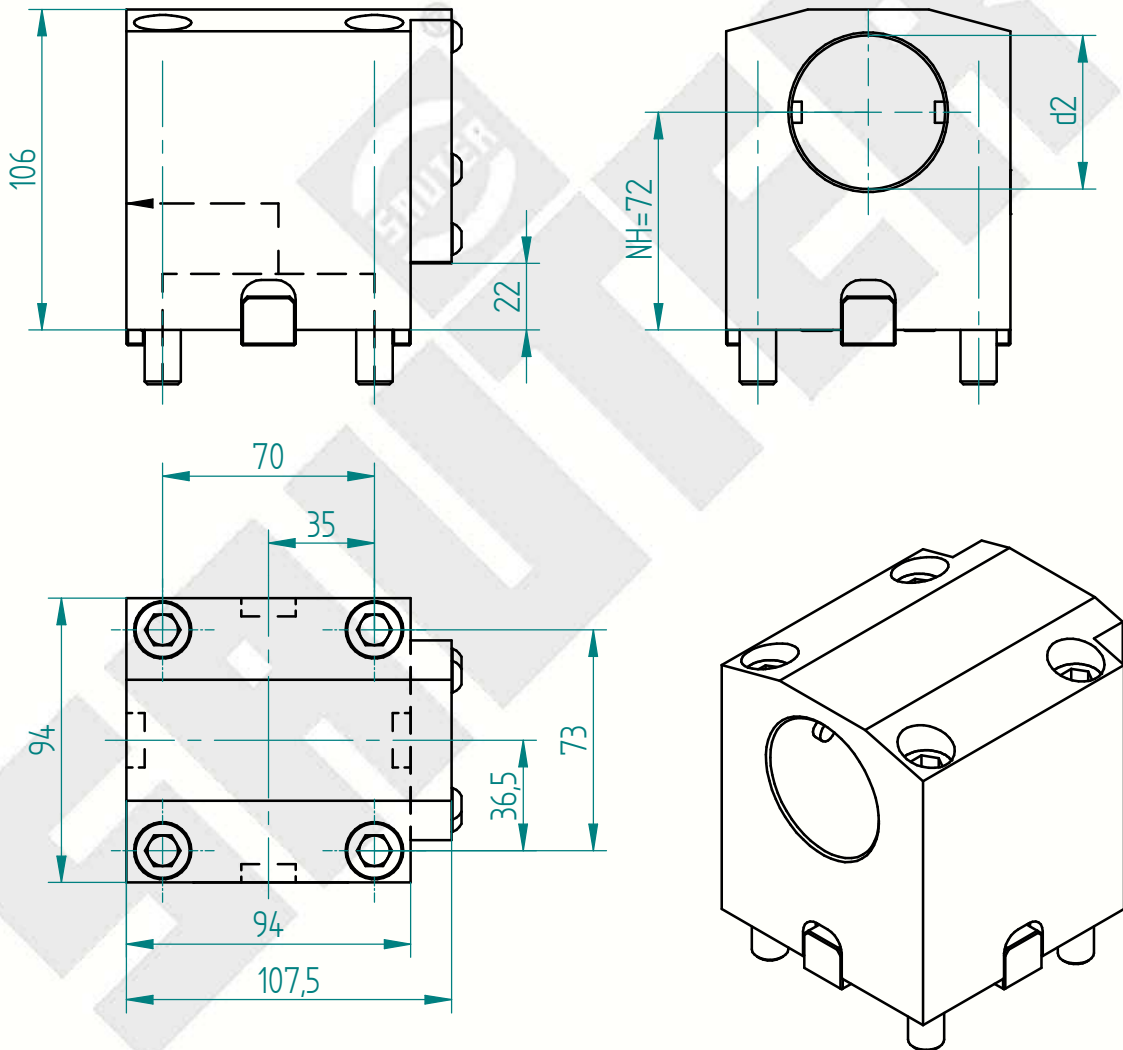

Schaft / BG shank / size		Werkzeugaufnahme tool location	Ausführung version	Bestell-Nr. order N°
d1 mm	l1 mm	Aufnahme d2 location d2		
65.0		Bohrstangenhalter mit Gewindest.-2.0"	gerade straight	178565

Erforderliche(r) Schlüssel zur Werkzeugspannung / necessary key(s) for tool clamping
(nicht im Lieferumfang enthalten / not included in delivery)

Inbusschlüssel / Allen head wrench



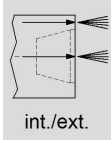
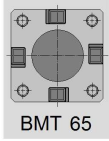

int. 80 bar
ext. 80 bar

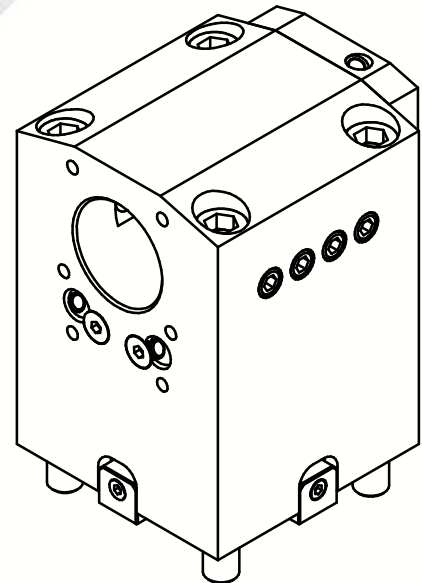
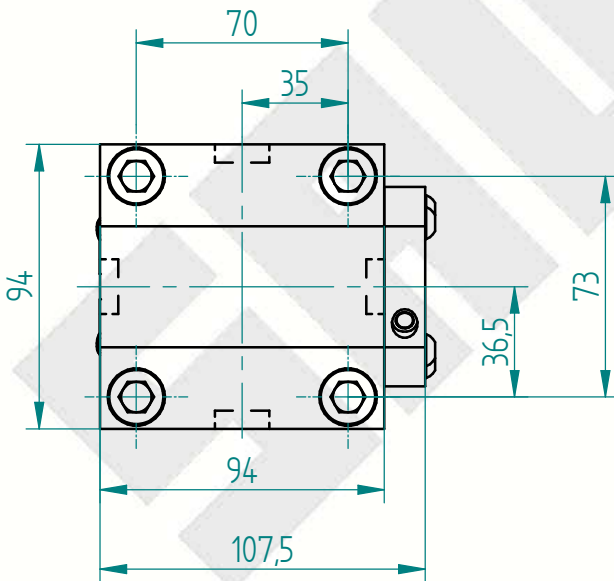
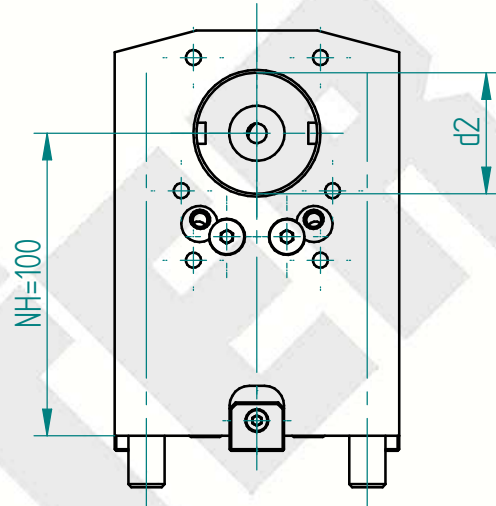
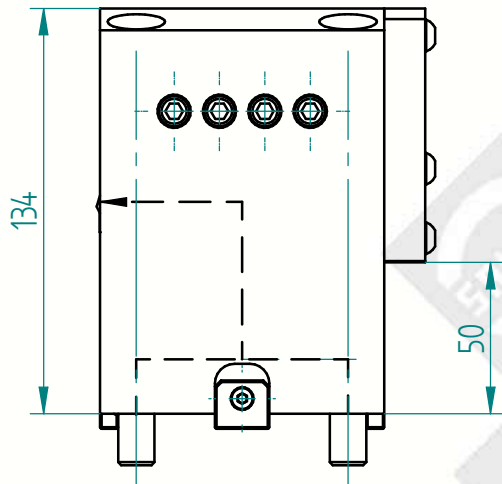

Änderungen vorbehalten. Subject to modification

Schaft / BG shank / size		Werkzeugaufnahme tool location	Ausführung version	Bestell-Nr. order N°
d1 mm	l1 mm	Aufnahme d2 location d2		
65.0		Bohrstangenhalter mit Gewindestift-40	gerade straight	178566

Erforderliche(r) Schlüssel zur Werkzeugspannung / necessary key(s) for tool clamping
(nicht im Lieferumfang enthalten / not included in delivery)

Inbusschlüssel / Allen head wrench



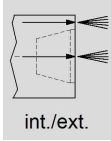
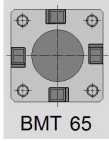

int. 80 bar
ext. 80 bar

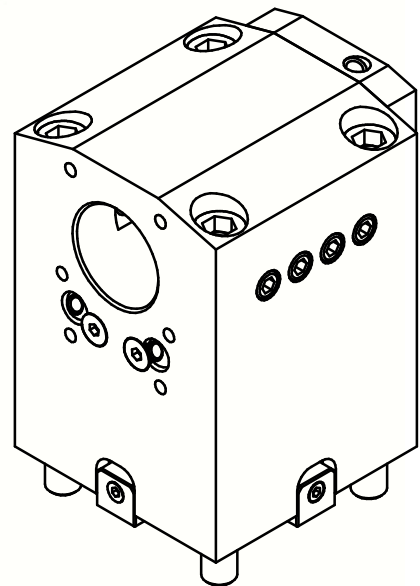
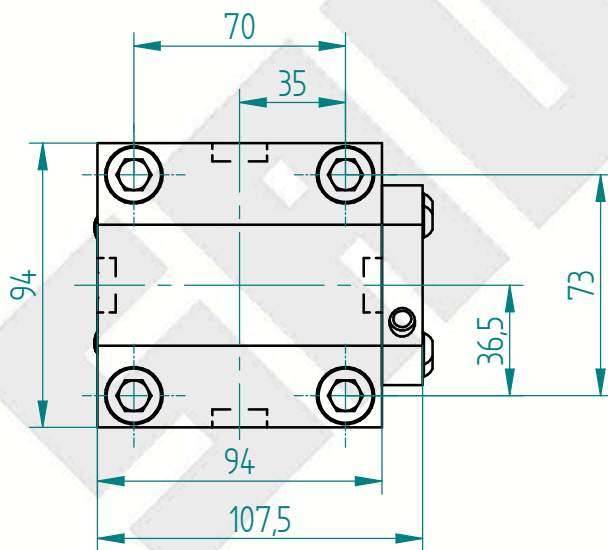
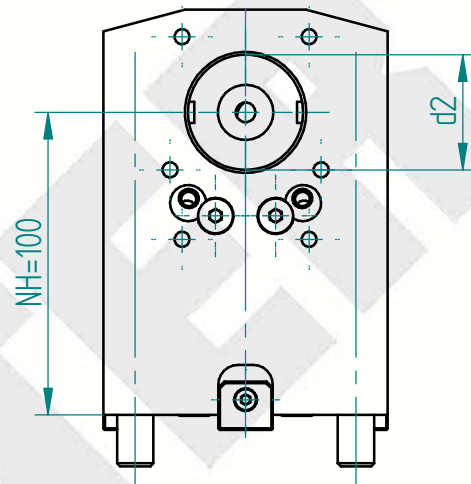
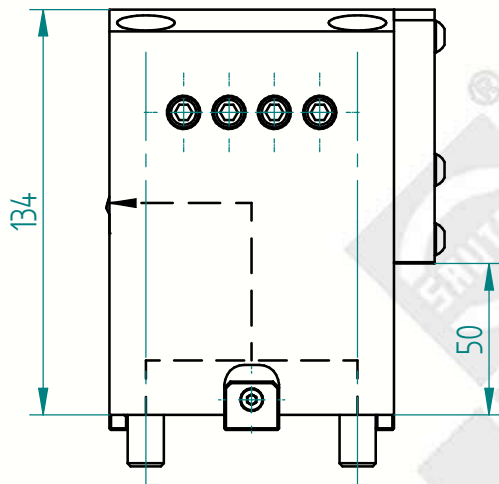

Schaft / BG shank / size		Werkzeugaufnahme tool location	Ausführung version	Bestell-Nr. order N°
d1 mm	l1 mm	Aufnahme d2 location d2		
65.0		Bohrstangenhalter mit Gewindest.-1.5"	gerade straight	178567

Erforderliche(r) Schlüssel zur Werkzeugspannung / necessary key(s) for tool clamping
(nicht im Lieferumfang enthalten / not included in delivery)

Inbusschlüssel / Allen head wrench



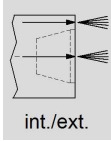
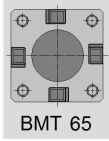

int. 80 bar
ext. 80 bar

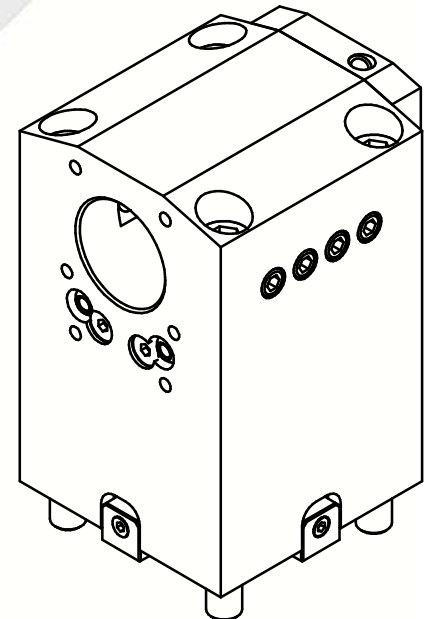
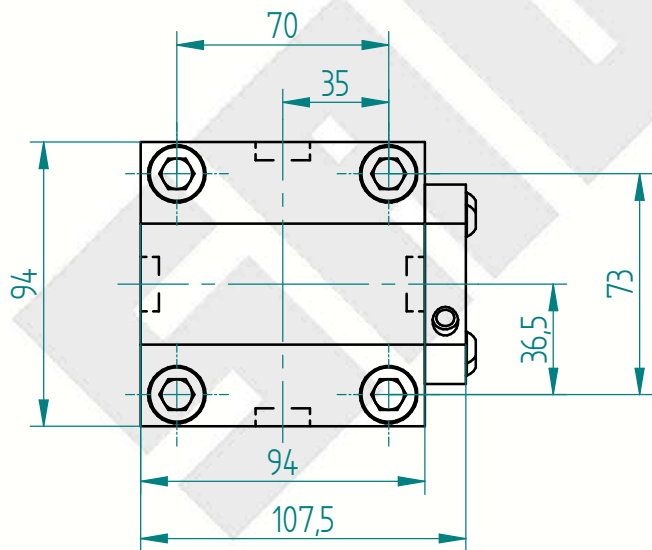
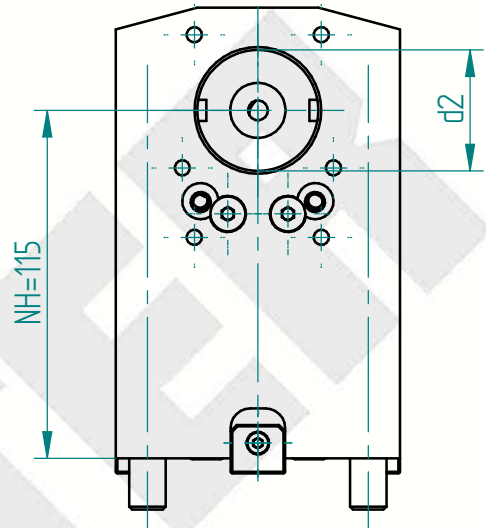
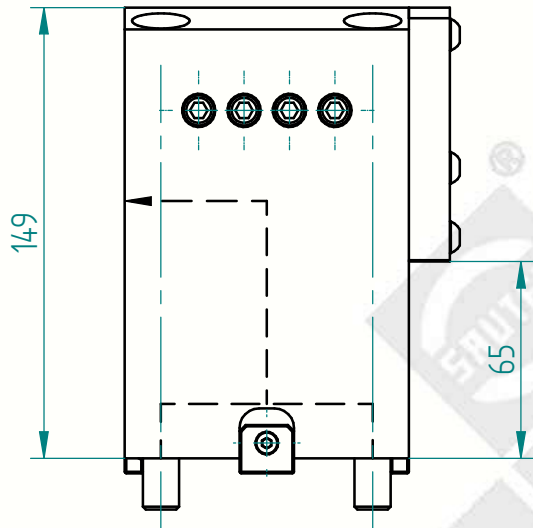

Schaft / BG shank / size		Werkzeugaufnahme tool location	Ausführung version	Bestell-Nr. order N°
d1 mm	l1 mm	Aufnahme d2 location d2		
65.0		Bohrstangenhalter mit Gewindestift-40	gerade straight	178568

Erforderliche(r) Schlüssel zur Werkzeugspannung / necessary key(s) for tool clamping
(nicht im Lieferumfang enthalten / not included in delivery)

Inbusschlüssel / Allen head wrench



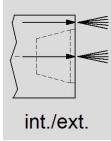
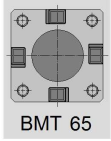

int. 80 bar
ext. 80 bar

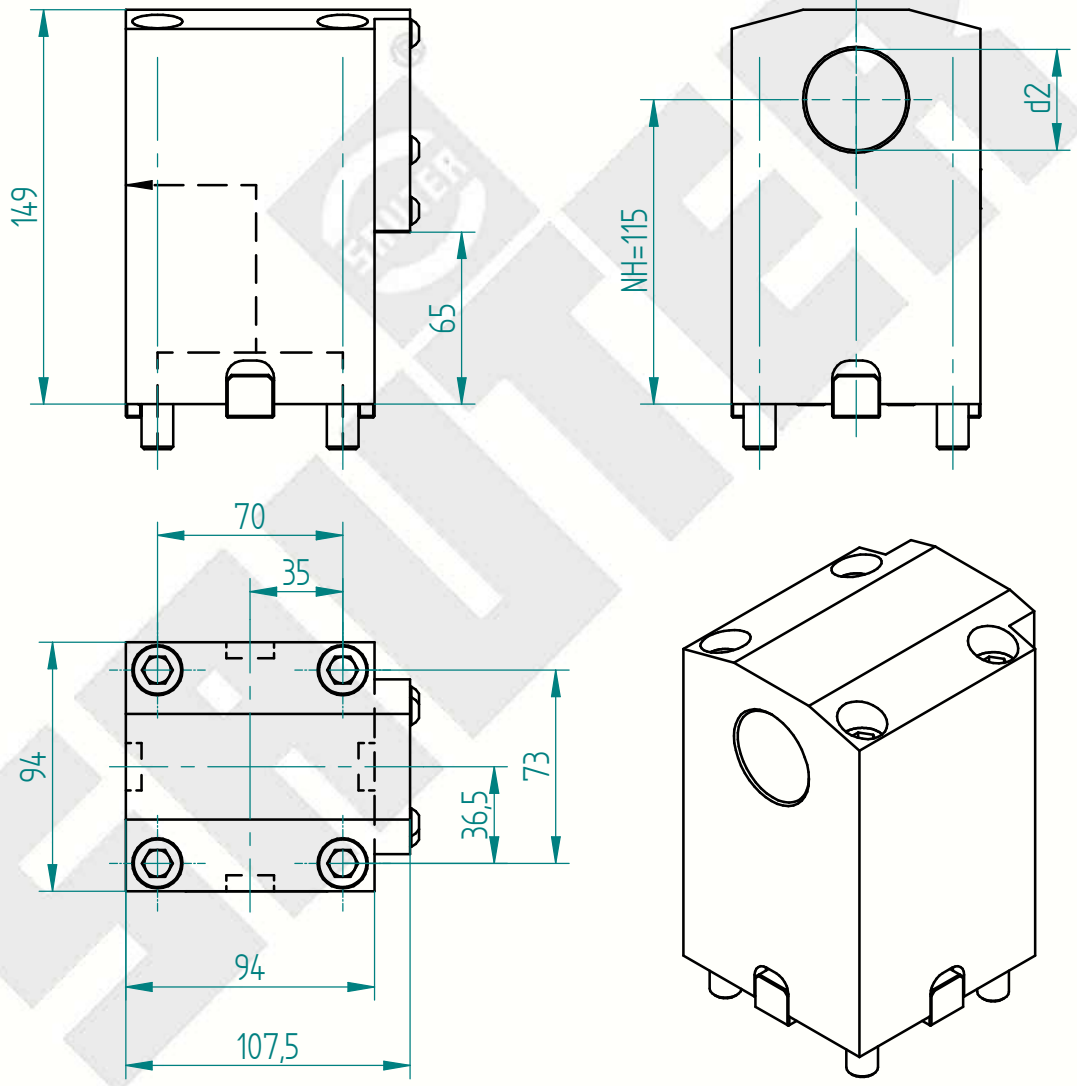

Schaft / BG shank / size		Werkzeugaufnahme tool location	Ausführung version	Bestell-Nr. order N°
d1 mm	l1 mm	Aufnahme d2 location d2		
65.0		Bohrstangenhalter mit Gewindest.-1.5"	gerade straight	178569

Erforderliche(r) Schlüssel zur Werkzeugspannung / necessary key(s) for tool clamping
(nicht im Lieferumfang enthalten / not included in delivery)

Inbusschlüssel / Allen head wrench



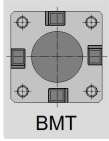

int. bar
ext. bar

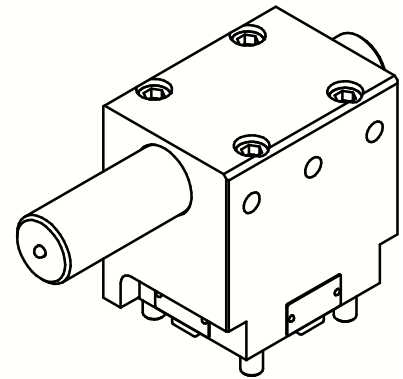
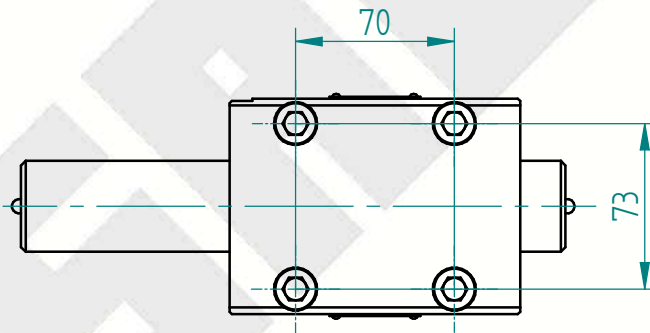
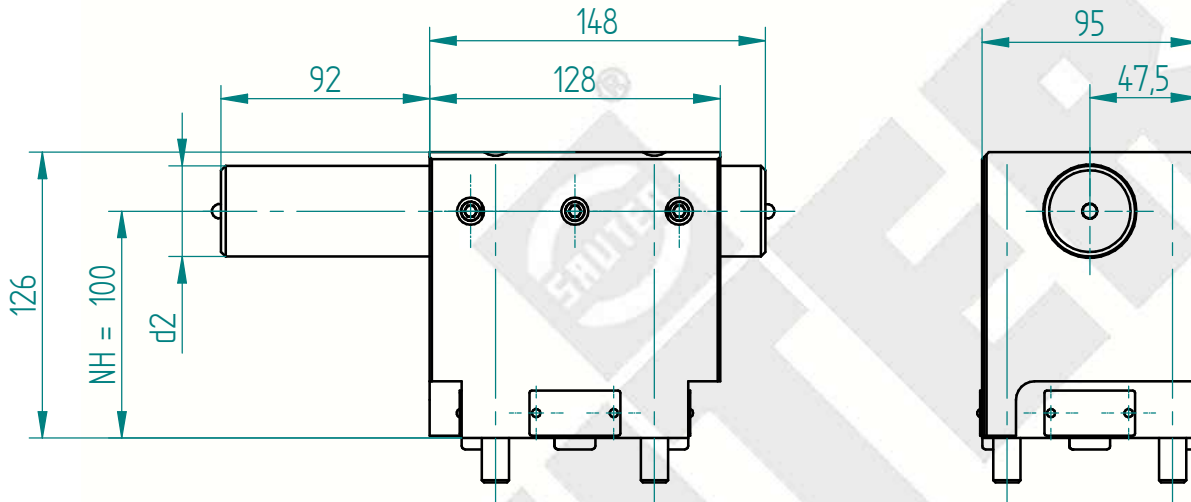

Schnittstelle Revolver interface tool turret	Werkzeugaufnahme tool location	Ausführung version	Bestell-Nr. order N°
BMT 65	Aufnahme d2 location d2 Pruefdorn-40	universal universal	151239

Erforderliche(r) Schlüssel zur Werkzeugspannung / necessary key(s) for tool clamping

Inbusschlüssel / Allen head wrench

