

Produktinformation PI 07.2
product information PI 07.2

Werkzeughalter mit Zylinderschaft
gem. DIN 69 880

Tool holders with parallel shank
acc. to DIN 69 880

2015-06-26

HINWEIS:

Die in dieser Produktinformation enthaltenen Informationen beruhen auf den zum Zeitpunkt der Drucklegung vorhandenen Erkenntnissen. Änderungen, die sich im Rahmen der ständigen Weiterentwicklung ergeben, behalten wir uns ausdrücklich vor.

Note

The information contained in this Product Information is in conformity with the knowledge at the point of printing. Subject to modification which occur within the framework of continuous further development.

Hierzu Preisliste P 31

see price list P 31



Inhaltsverzeichnis

Table of contents

	Form <i>form</i>	Seite <i>page</i>
Werkzeughalter vorgearbeitet, rechteckig <i>Tool Holder Blank, rectangular</i>	A1	7
Werkzeughalter vorgearbeitet, rund <i>Tool holder Blank, round</i>	A2	7
Werkzeugaufnahme quer, rechts, kurz <i>Tool Holder Blank, right hand, short</i>	B1	8
Werkzeugaufnahme quer, links, kurz <i>Tool Holder Blank, left hand, short</i>	B2	8
Werkzeugaufnahme quer Überkopf, rechts, kurz <i>Tool Holder Blank, Overhead, right hand, short</i>	B3	9
Werkzeugaufnahme quer Überkopf, links, kurz <i>Tool Holder Blank Overhead, left hand, short</i>	B4	9
Werkzeugaufnahme quer rechts, lang <i>Tool Holder Blank, right hand, long</i>	B5	10
Werkzeugaufnahme quer, links, lang <i>Tool Holder Blank, left hand, long</i>	B6	10
Werkzeugaufnahme Überkopf, rechts, lang <i>Tool Holder Blank Overhead, right hand, long</i>	B7	11
Werkzeugaufnahme Überkopf, links, lang <i>Tool Holder Blank Overhead, left hand, long</i>	B8	11
Werkzeughalter-Längsaufnahme, rechts <i>Turning Tool Holder for Square Tool, right hand</i>	C1	12
Werkzeughalter-Längsaufnahme, links <i>Turning Tool Holder for Square Tool, left hand</i>	C2	12
Werkzeughalter-Längsaufnahme, Überkopf, rechts <i>Turning Tool Holder for Square Tool, Overhead, right hand</i>	C3	13
Werkzeughalter-Längsaufnahme, Überkopf, links <i>Turning Tool Holder for Square Tool, Overhead, left hand</i>	C4	13
Werkzeugaufnahme-Mehrfachaufnahme, <i>Multi Purpose Square Tool Holder</i>	D1	14
Werkzeughalter-Längsaufnahme, Überkopf, <i>Multi Purpose Square Tool Holder, Overhead</i>	D2	14
Zylinderaufnahme für Drehwerkzeuge mit Zylinderschaft <i>Side Lock Adaptor for Turning-Tools with Cylindrical Shaft</i>	E2	15
Werkzeughalter mit Zylinderschaft für Werkzeuge mit innerer Kühlschmierstoffzuführung <i>Toolholder with Cylindrical Shaft for Tools with Inner Cooling System</i>	E1	16

	Form <i>Form</i>	Seite/ <i>Page</i>
Reduzierhülsen für Werkzeuge mit Zylinderschaft <i>Reducing Sleeve for Tools with Cylindrical Shaft</i>		17
Werkzeughalter mit Zylinderschaft mit Zylinderaufnahme durch Spannzange <i>Collet Chuck with cylindrical adaption by collet</i>	E3/E4	18
Spannzange Bezeichnung nach DIN 6499 <i>Collets acc. to DIN 6499</i>	B	20
Präzisions-Spannzange nach DIN 6499 Typ GER-HP <i>Precision Collet acc. to DIN 6499 Type GER-HP</i>		22
Spannzange mit Abdichtung für IK Typ CER-D <i>Collet with Sealing for IK Type CER-D</i>		24
Spannzange für Gewindebohrer mit Längenausgleich nach DIN 6499 <i>Collet for Tapping for Compentation acc. to DIN 6499</i>		26
Dichtscheibe für Spannmutter Typ ERZR...A mit Bohrung <i>Sealing Washer for Clamping Nuts Type ERZR...A with Bore</i>		28
Spannzange Bezeichnung nach DIN 6388 <i>Collet acc. to DIN 6388</i>	B	30
Spannschlüssel <i>Key</i>		32
Werkstoffanschlag mitlaufend, Länge verstellbar mit Schaft <i>Stock Stop Revolving, adjustable length</i>		32
Kegelaufnahme für Kegelschäfte mit Austreiblappen <i>Morse Taper Adaptor for Shanks with Teng</i>	F	33
Bohrstangenaufnahme mit Schaft <i>Boring Bar Adaptor with Shaft</i>		34
Reduzierbuchse für Werkzeuge mit Zylinderschaft <i>Reducing Sleeve for Tools with Cylindrical Shaft</i>		35
Reduzierhülse für DIN 69 880 <i>Reducing Sleeve for DIN 69 880</i>		36
Klemmring <i>Clamping Ring</i>	Z1	36
NC Kurzbohrfutter, mit Schaft <i>NC-Short Drill Chuck with Shaft</i>		37
NC Kurzbohrfutter mit Schaft <i>NC-Short Drill Chuck with Shaft</i>		38
Reduktion und Hinterlegscheiben für Schneideisen <i>Reduction and Deposit-Sheet Cutting Iron</i>		39

	Form Form	Seite/ Page
Gewindeschneidfutter mit Längenausgleich nach DIN 69 880 <i>Tapping Head acc. to DIN 69 880</i>		40
Stangengreifer mit Schaft nach DIN 69 880 <i>Bar Pick Up with Shaft acc. to DIN 69 880</i>		42
Stangengreifer mit Schaft nach DIN 69 880 rechts <i>Bar Pick Up with Shaft acc. to DIN 69 880 right hand</i>		42
Stangengreifer mit Schaft nach DIN 69 880 links <i>Bar Pick Up with Shaft acc. to DIN 69 880 left hand</i>		43
Verschlußstopfen, wahlweise aus Stahl oder Kunststoff DIN 69 880 <i>Plug, made either from Steel or Plastic DIN 69 880</i>	Z2	44
Einrichtehalter mit Schaft nach DIN 69 880 <i>Setting-Holder with Shaft to DIN 69 880</i>		45
Prüfdorn mit Schaft nach DIN 69 880 <i>Test Mandrel with Shaft to DIN 69 880</i>		45
Blockwerkzeughalter <i>Block Tool Holder</i>		46
Blockwerkzeughalter für Bohrstangen, Kühlschmierstoffzuführung extern / intern <i>Block Tool Holder for Boring Bar, coolant supply external / internal</i>		47
Blockwerkzeughalter für Werkzeughalter, DIN 69 880 <i>Block Tool Holder for Tool Holder, DIN 69 880</i>		48

Hinweis:

O-Ring

Bei Werkzeug-Scheibenrevolvern, die eine zusätzliche Abdichtung am Zylinderschaft der Werkzeuge benötigen, muss separat ein O-Ring bestellt werden.

O-Ring entsprechend dem Zylinderschaft auswählen, siehe Tabelle.

Note:

O-ring

For disk-type tool turrets which need an additional seal at the cylindrical shaft of the tools you have to order an o-ring separately.

Select the o-ring in accordance with the cylindrical shafts, see table.

Ø - Zylinderschaft <i>Ø - Cylindrical shaft</i>	O-Ring Ident-Nr. <i>Ident-No.</i>	O-Ring Größe <i>Size</i>
16	059149	15 x 1,5
20	067359	19 x 1,8
25	088198	23,6 x 1,8
30	075521	28,3 x 1,78
40	078596	38,7 x 2,65
50	083562	47,5 x 2,65

Werkzeughalter vorgearbeitet DIN 69 880 Teil 2 Form A1 rechteckig

Tool holder blank DIN 69 880 Part 2 Form A1 rectangular

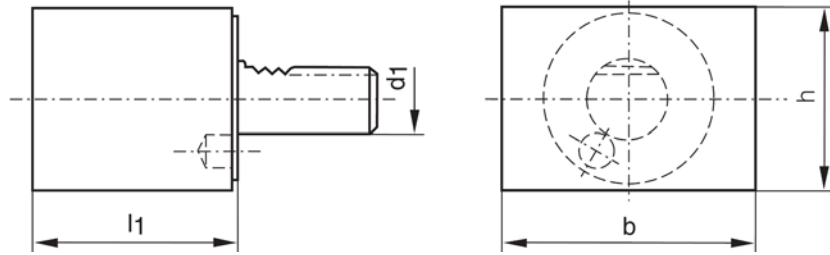

Bezeichnung <i>name</i>	Ident-Nr. <i>Ident-No.</i>	d ₁	l ₁	b	h
A1 - 16 x 44	114489	16	44	78	44
A1 - 20 x 50	114490	20	50	60	60
A1 - 20 x 65	114491	20	65	100	60
A1 - 25 x 75	114492	25	75	100	60
A1 - 30 x 85	114493	30	85	130	76
A1 - 40 x 100	114494	40	100	151	96
A1 - 50 x 125	114495	50	125	160	120
A1 - 60 x 160	114496	60	160	165	125

Werkzeughalter vorgearbeitet DIN 69 880 Teil 2 Form A2 rund

Tool holder blank DIN 69 880 Part 2 Form A2 round

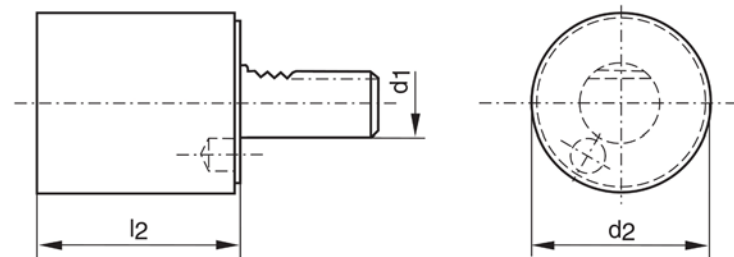

Bezeichnung / <i>name</i>	Ident-Nr. / <i>Ident-No.</i>	d ₁	d ₂	l ₂
A2 - 16 x 60	114497	16	40	60
A2 - 20 x 70	114498	20	50	70
A2 - 20 x 160	114499	20	52	160
A2 - 25 x 80	114500	25	58	80
A2 - 25 x 200	114501	25	58	200
A2 - 30 x 100	114502	30	68	100
A2 - 30 x 150	114503	30	68	150
A2 - 30 x 200	114504	30	70	200
A2 - 30 x 240	114505	30	68	240
A2 - 40 x 120	114506	40	83	120
A2 - 40 x 150	114507	40	83	150
A2 - 40 x 200	114508	40	83	200
A2 - 40 x 320	114509	40	83	320
A2 - 50 x 135	114510	50	98	135
A2 - 50 x 220	114511	50	98	220
A2 - 50 x 400	114512	50	98	400
A2 - 60 x 150	114513	60	123	150
A2 - 60 x 250	114514	60	123	250
A2 - 60 x 480	114515	60	123	480

Werkzeugaufnahme quer DIN 69 880 Teil 3 Form B1 rechts, kurz

Turning Tool DIN 69 880 Part 3 Form B1 right hand, short

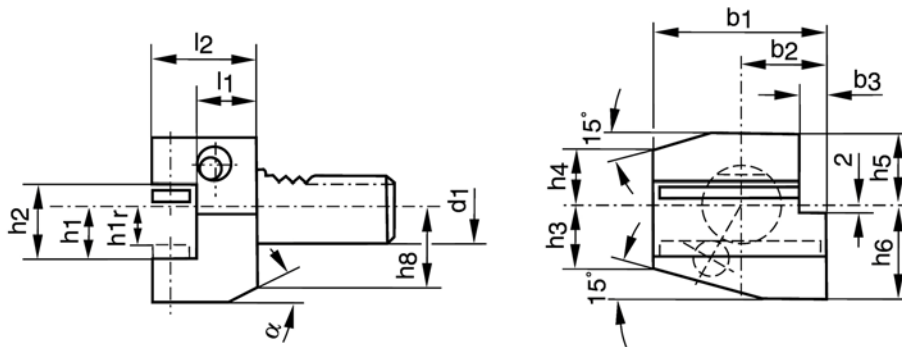

Bezeichnung designation	Ident-Nr. Ident-No.	d ₁	b ₁	b ₂	b ₃	h ₁ /h _{1r}	h ₂	h ₃	h ₄	h ₅	h ₆	h ₈	l ₁ +0,5	l ₂	α
B1 - 16 x 12	113638	16	42	23	5	12	17	15	15	20	22	19	13	24	30°
B1 - 16 x 12	113888	16	42	23	5	12	17	15	15	20	22	19	23	34	30°
B1 - 20 x 16	113889	20	55	30	7	16/12	22	19	19	25	30	23	16	30	30°
B1 - 20 x 16	113890	20	55	30	7	16/12	22	19	19	25	30	23	26	40	40°
B1 - 25 x 16	113891	25	55	30	7	16/12	22	22,5	22,5	25	30	25	16	30	30°
B1 - 25 x 16	113892	25	55	30	7	16/12	22	22,5	22,5	25	30	25	26	40	40°
B1 - 30 x 20	113893	30	70	35	10	20/16	29	26	22	28	38	30	22	40	25°
B1 - 30 x 20	113894	30	70	35	10	20/16	29	26	22	28	38	30	42	60	25°
B1 - 40 x 25	113895	40	85	42,5	12,5	25/20	34	35	30	32,5	48		22	44	
B1 - 50 x 32	113896	50	100	50	16	32/25	41	42	35	35	60		30	55	
B1 - 60 x 32	113897	60	125	62,5	16	32/25	41	46	42,5	42,5	62,5		30	60	

Werkzeugaufnahme quer DIN 69 880 Teil 3 Form B2 links, kurz

Turning Tool DIN 69 880 Part 3 Form B2 left hand, short

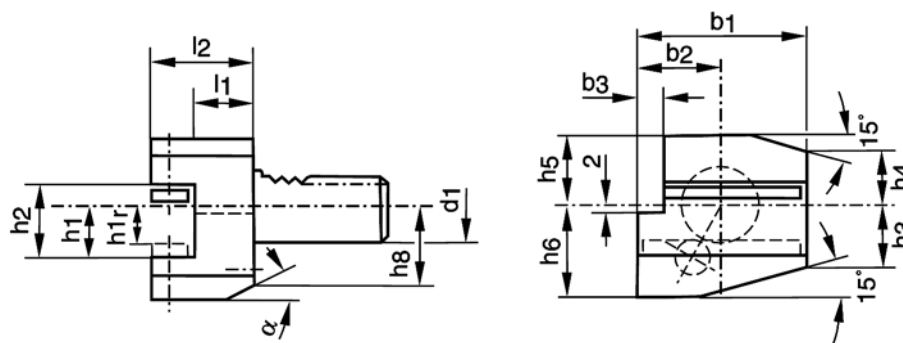

Bezeichnung designation	Ident-Nr. Ident-No.	d ₁	b ₁	b ₂	b ₃	h ₁ /h _{1r}	h ₂	h ₃	h ₄	h ₅	h ₆	h ₈	l ₁ +0,5	l ₂	α
B2 - 16 x 12	113898	16	42	23	5	12	17	15	15	20	22	19	13	24	30°
B2 - 16 x 12	113899	16	42	23	5	12	17	15	15	20	22	19	23	34	30°
B2 - 20 x 16	113900	20	55	30	7	16/12	22	19	19	25	30	23	16	30	30°
B2 - 20 x 16	113901	20	55	30	7	16/12	22	19	19	25	30	23	26	40	30°
B2 - 25 x 16	113902	25	55	30	7	16/12	22	22,5	22,5	25	30	25	16	30	30°
B2 - 25 x 16	113903	25	55	30	7	16/12	22	22,5	22,5	25	30	25	26	40	30°
B2 - 30 x 20	113904	30	70	35	10	20/16	29	26	22	28	38	30	22	40	25°
B2 - 30 x 20	113905	30	70	35	10	20/16	29	26	22	28	38	30	42	60	25°
B2 - 40 x 25	113906	40	85	42,5	12,5	25/20	34	35	30	32,5	48		22	44	
B2 - 50 x 32	113907	50	100	50	16	32/25	41	42	35	35	60		30	55	
B2 - 60 x 32	113908	60	125	62,5	16	32/25	41	46	42,5	42,5	62,5		30	60	

Werkzeugaufnahme quer Überkopf DIN 69 880 Teil 3 Form B3 rechts, kurz

Turning Tool Overhead DIN 69 880 Part 3 Form B3 right hand, short

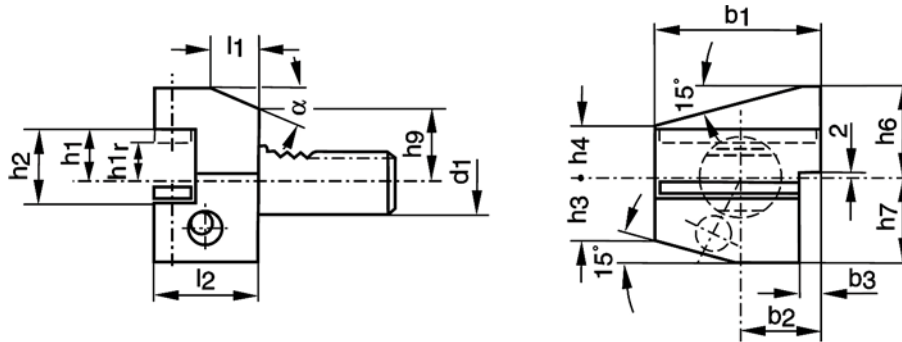

Bezeichnung designation	Ident-Nr. Ident-No.	d ₁	b ₁	b ₂	b ₃	h ₁ /h _{1r}	h ₂	h ₃	h ₄	h ₆	h ₇	h ₉	l ₁ ^{+0,5}	l ₂	α
B3 - 16 x 12	113909	16	42	23	5	12	17	15	15	22	20	19	13	24	30°
B3 - 16 x 12	113910	16	42	23	5	12	17	15	15	22	20	19	23	34	30°
B3 - 20 x 16	113911	20	55	30	7	16/12	22	19	19	30	25	23	16	30	30°
B3 - 20 x 16	113912	20	55	30	7	16/12	22	19	19	30	25	23	26	40	30°
B3 - 25 x 16	113913	25	55	30	7	16/12	22	22,5	22,5	30	25	25	16	30	30°
B3 - 25 x 16	113914	25	55	30	7	16/12	22	22,5	22,5	30	25	25	26	40	30°
B3 - 30 x 20	113915	30	70	35	10	20/16	29	26	22	38	35	28	22	40	25°
B3 - 30 x 20	113916	30	70	35	10	20/16	29	26	22	38	35	28	42	60	25°
B3 - 40 x 25	113917	40	85	42,5	12,5	25/20	34	35	30	48	42,5		22	44	
B3 - 50 x 32	113918	50	100	50	16	32/25	41	42	35	60	50		30	55	
B3 - 60 x 32	113919	60	125	62,5	16	32/25	41	46	42,5	62,5	62,5		30	60	

Werkzeugaufnahme quer Überkopf DIN 69 880 Teil 3 Form B4 links, kurz

Turning Tool Overhead DIN 69 880 Part 3 Form B4 left hand, short

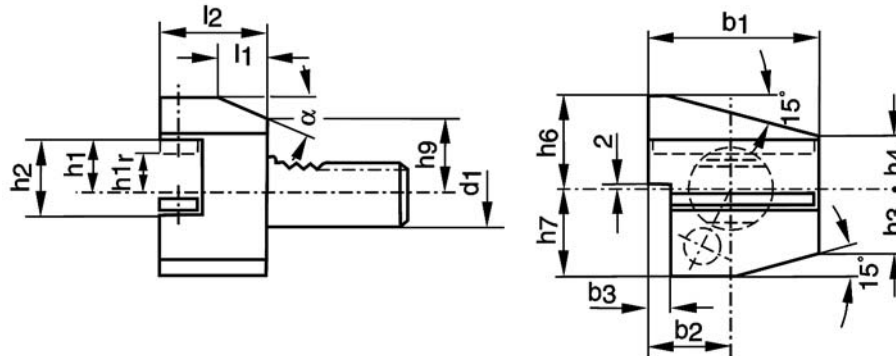

Bezeichnung designation	Ident-Nr. Ident-No.	d ₁	b ₁	b ₂	b ₃	h ₁ /h _{1r}	h ₂	h ₃	h ₄	h ₆	h ₇	h ₉	l ₁ ^{+0,5}	l ₂	α
B4 - 16 x 12	113920	16	42	23	5	12	17	15	15	22	20	19	13	24	30°
B4 - 16 x 12	113921	16	42	23	5	12	17	15	15	22	20	19	23	34	30°
B4 - 20 x 16	113922	20	55	30	7	16/12	22	19	19	30	25	23	16	30	30°
B4 - 20 x 16	113923	20	55	30	7	16/12	22	19	19	30	25	23	26	40	30°
B4 - 25 x 16	113924	25	55	30	7	16/12	22	22,5	22,5	30	25	25	16	30	30°
B4 - 25 x 16	113925	25	55	30	7	16/12	22	22,5	22,5	30	25	25	26	40	30°
B4 - 30 x 20	113926	30	70	35	10	20/16	29	26	22	38	35	28	22	40	25°
B4 - 30 x 20	113927	30	70	35	10	20/16	29	26	22	38	35	28	42	60	25°
B4 - 40 x 25	113928	40	85	42,5	12,5	25/20	34	35	30	48	42,5		22	44	
B4 - 50 x 32	113929	50	100	50	16	32/25	41	42	35	60	50		30	55	
B4 - 60 x 32	113930	60	125	62,5	16	32/25	41	46	42,5	62,5	62,5		30	60	

Werkzeugaufnahme quer DIN 69 880 Teil 3 Form B5 rechts, lang

Turning Tool DIN 69 880 Part 3 Form B5 right hand, long

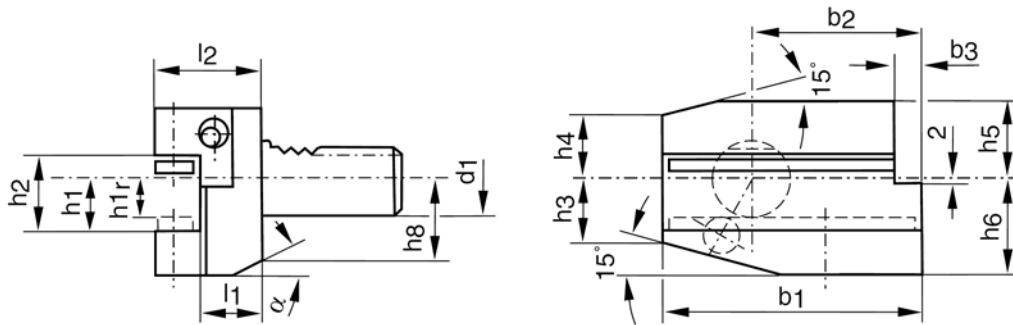

Bezeichnung designation	Ident-Nr. Ident-No.	d ₁	b ₁	b ₂	b ₃	h ₁ /h _{1r}	h ₂	h ₃	h ₄	h ₅	h ₆	h ₈	l ₁ +0,5	l ₂	α
B5 - 16 x 12	113931	16	58	39	5	12	17	15	15	20	22	19	13	24	30°
B5 - 16 x 12	113932	16	58	39	5	12	17	15	15	20	22	19	23	34	30°
B5 - 20 x 16	113933	20	75	50	7	16/12	22	19	19	25	30	23	16	30	30°
B5 - 20 x 16	113934	20	75	50	7	16/12	22	19	19	25	30	23	26	40	30°
B5 - 25 x 16	113935	25	75	50	7	16/12	22	22,5	22,5	25	30	25	16	30	30°
B5 - 25 x 16	113936	25	75	50	7	16/12	22	22,5	22,5	25	30	25	26	40	30°
B5 - 30 x 20	113941	30	100	65	10	20/16	29	26	22	28	38	30	22	40	25°
B5 - 30 x 20	113937	30	100	65	10	20/16	29	26	22	28	38	30	42	60	25°
B5 - 40 x 25	113938	40	118	75,5	12,5	25/20	34	35	30	32,5	48		22	44	
B5 - 50 x 32	113939	50	130	80	16	32/25	41	42	35	35	60		30	55	
B5 - 60 x 32	113940	60	145	82,5	16	32/25	41	46	42,5	42,5	62,5		30	60	

Werkzeugaufnahme quer DIN 69 880 Teil 3 Form B6 links, lang

Turning Tool DIN 69 880 Part 3 Form B6 left hand, long

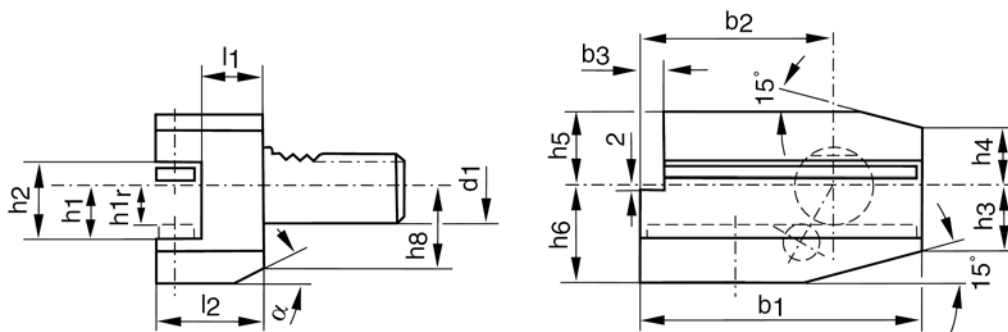

Bezeichnung designation	Ident-Nr. Ident-No.	d ₁	b ₁	b ₂	b ₃	h ₁ /h _{1r}	h ₂	h ₃	h ₄	h ₅	h ₆	h ₈	l ₁ +0,5	l ₂	α
B6 - 16 x 12	113942	16	58	39	5	12	17	15	15	20	22	19	13	24	30°
B6 - 16 x 12	113943	16	58	39	5	12	17	15	15	20	22	19	23	34	30°
B6 - 20 x 16	113944	20	75	50	7	16/12	22	19	19	25	30	23	16	30	30°
B6 - 20 x 16	113945	20	75	50	7	16/12	22	19	19	25	30	23	26	40	30°
B6 - 25 x 16	113946	25	75	50	7	16/12	22	22,5	22,5	25	30	25	16	30	30°
B6 - 25 x 16	113947	25	75	50	7	16/12	22	22,5	22,5	25	30	25	26	40	30°
B6 - 30 x 20	113948	30	100	65	10	20/16	29	26	22	28	38	30	22	40	25°
B6 - 30 x 20	113949	30	100	65	10	20/16	29	26	22	28	38	30	42	60	25°
B6 - 40 x 25	113950	40	118	75,5	12,5	25/20	34	35	30	32,5	48		22	44	
B6 - 50 x 32	113951	50	130	80	16	32/25	41	42	35	35	60		30	55	
B6 - 60 x 32	113952	60	145	82,5	16	32/25	41	46	42,5	42,5	62,5		30	60	

Werkzeugaufnahme Überkopf DIN 69 880 Teil 3 Form **B7** rechts, lang

Turning Tool Overhead DIN 69 880 Part 3 Form **B7** right hand, long

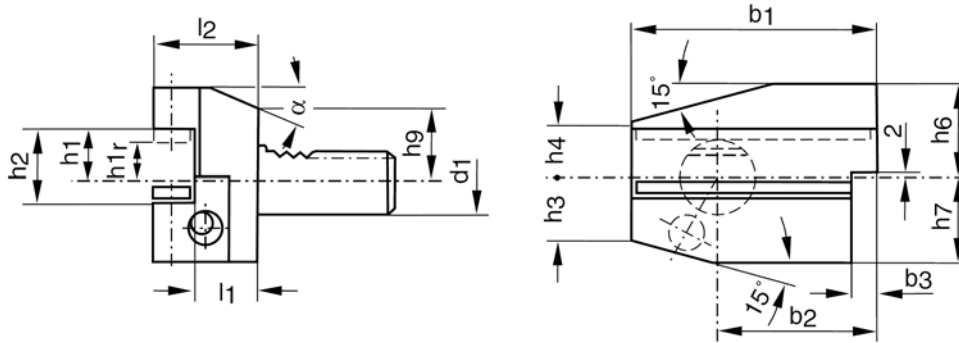

Bezeichnung <i>designation</i>	Ident-Nr. <i>Ident-No.</i>	d ₁	b ₁	b ₂	b ₃	h ₁ /h _{1r}	h ₂	h ₃	h ₄	h ₆	h ₇	h ₉	l ₁ ^{+0,5}	l ₂	α
B7 - 16 x 12	114066	16	58	39	5	12	17	15	15	22	20	19	13	24	30°
B7 - 16 x 12	114065	16	58	39	5	12	17	15	15	22	20	19	23	34	30°
B7 - 20 x 16	114064	20	75	50	7	16/12	22	19	19	30	25	23	16	30	30°
B7 - 20 x 16	114063	20	75	50	7	16/12	22	19	19	30	25	23	26	40	30°
B7 - 25 x 16	114062	25	75	50	7	16/12	22	22,5	22,5	30	25	25	16	30	30°
B7 - 25 x 16	114061	25	75	50	7	16/12	22	22,5	22,5	30	25	25	26	40	30°
B7 - 30 x 20	114060	30	100	65	10	20/16	29	26	22	38	35	28	22	40	25°
B7 - 30 x 20	114059	30	100	65	10	20/16	29	26	22	38	35	28	42	60	25°
B7 - 40 x 25	114058	40	118	75,5	12,5	25/20	34	35	30	48	42,5		22	44	
B7 - 50 x 32	114057	50	130	80	16	32/25	41	42	35	60	50		30	55	
B7 - 60 x 32	114056	60	145	82,5	16	32/25	41	46	42,5	62,5	62,5		30	60	

Werkzeugaufnahme Überkopf DIN 69 880 Teil 3 Form **B8** links, lang

Turning Tool Overhead DIN 69 880 Part 3 Form **B8** left hand, long

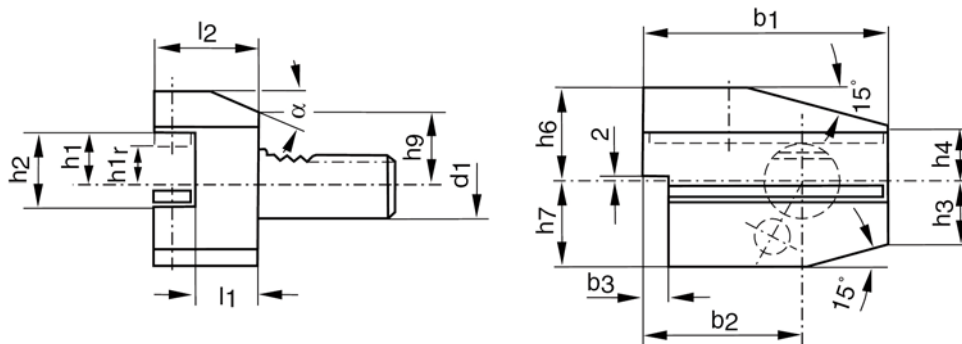

Bezeichnung <i>designation</i>	Ident-Nr. <i>Ident-No.</i>	d ₁	b ₁	b ₂	b ₃	h ₁ /h _{1r}	h ₂	h ₃	h ₄	h ₆	h ₇	h ₉	l ₁ ^{+0,5}	l ₂	α
B8 - 16 x 12	114055	16	58	39	5	12	17	15	15	22	20	19	13	24	30°
B8 - 16 x 12	114054	16	58	39	5	12	17	15	15	22	20	19	23	34	30°
B8 - 20 x 16	114053	20	75	50	7	16/12	22	19	19	30	25	23	16	30	30°
B8 - 20 x 16	114052	20	75	50	7	16/12	22	19	19	30	25	23	26	40	30°
B8 - 25 x 16	114051	25	75	50	7	16/12	22	22,5	22,5	30	25	25	16	30	30°
B8 - 25 x 16	114050	25	75	50	7	16/12	22	22,5	22,5	30	25	25	26	40	30°
B8 - 30 x 20	114049	30	100	65	10	20/16	29	26	22	38	35	28	22	40	25°
B8 - 30 x 20	114048	30	100	65	10	20/16	29	26	22	38	35	28	42	60	25°
B8 - 40 x 25	114047	40	118	75,5	12,5	25/20	34	35	30	48	42,5		22	44	
B8 - 50 x 32	114046	50	130	80	16	32/25	41	42	35	60	50		30	55	
B8 - 60 x 32	114045	60	145	82,5	16	32/25	41	46	42,5	62,5	62,5		30	60	

Werkzeughalter-Längsaufnahme DIN 69 880 Teil 4 Form C1 rechts

Turning Tool Holder for Square Tool DIN 69 880 Part 4 Form C1 right hand

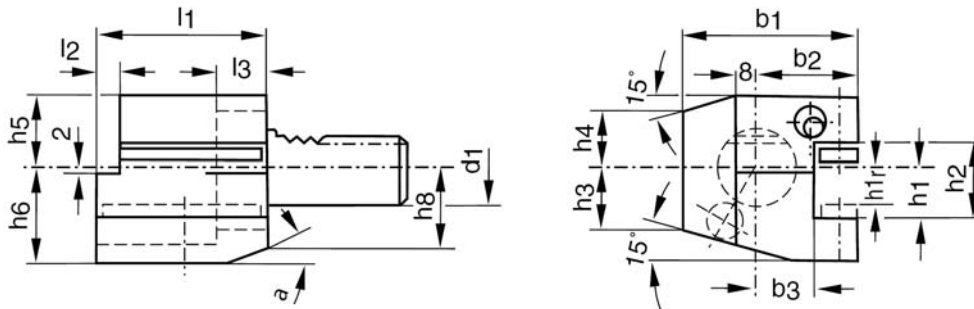

Bezeichnung designation	Ident-Nr. Ident-No.	d ₁	b ₁	b ₂	b ₃ ^{+0,5}	h ₁ /h _{1r}	h ₂	h ₃	h ₄	h ₅	h ₆	h ₈	l ₁	l ₂	l ₃	α
C1 - 16 x 12	114044	16	43	24	13	12	17	15	15	20	22	19	44	5	20	30°
C1 - 20 x 16	114043	20	52	27	13	16/12	22	19	19	25	30	23	55	7	30	30°
C1 - 25 x 16	114041	25	58	33	19	16/12	22	22,5	22,5	25	30	25	55	7	20	30°
C1 - 30 x 20	114040	30	70	35	17	20/16	29	26	22	28	38	30	70	10	30	25°
C1 - 40 x 25	114039	40	85	42,5	20,5	25/20	34	35	30	32,5	48		85	12,5	30	
C1 - 50 x 32	114038	50	100	50	25,5	32/25	41	42	35	35	60		100	16	40	
C1 - 60 x 32	114037	60	125	62,5	32,5	32/25	41	46	42,5	42,5	62,5		125	16	40	

Werkzeughalter-Längsaufnahme DIN 69 880 Teil 4 Form C2 links

Turning Tool Holder for Square Tool DIN 69 880 Part 4 Form C2 left hand

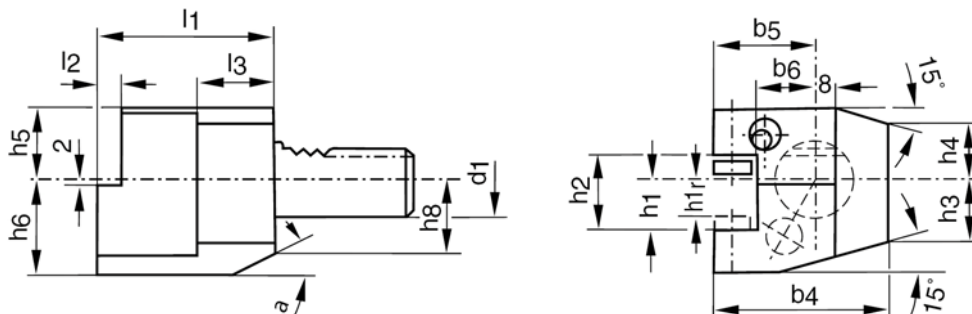

Bezeichnung designation	Ident-Nr. Ident-No.	d ₁	b ₄	b ₅	b ₆ ^{+0,5}	h ₁ /h _{1r}	h ₂	h ₃	h ₄	h ₅	h ₆	h ₈	l ₁	l ₂	l ₃	α
C2 - 16 x 12	114036	16	43	24	13	12	17	15	15	20	22	19	44	5	20	30°
C2 - 20 x 16	114035	20	65	40	26	16/12	22	19	19	25	30	23	50		30	30°
C2 - 25 x 16	114034	25	58	33	19	16/12	22	22,5	22,5	25	30	25	55	7	20	30°
C2 - 30 x 20	114033	30	76	41	23	20/16	29	26	22	28	38	30	70	10	30	25°
C2 - 40 x 25	114032	40	90	47,5	25,5	25/20	34	35	30	32,5	48		85	12,5	30	
C2 - 50 x 32	114031	50	105	55	30,5	32/25	41	42	35	35	60		100	16	40	
C2 - 60 x 32	114030	60	125	62,5	32,5	32/25	41	46	42,5	42,5	62,5		125	16	40	

Werkzeughalter-Längsaufnahme Überkopf DIN 69 880 Teil 4 Form C3 rechts

Turning Tool Holder for Square Tool Overhead DIN 69 880 Part 4 Form C3 right hand

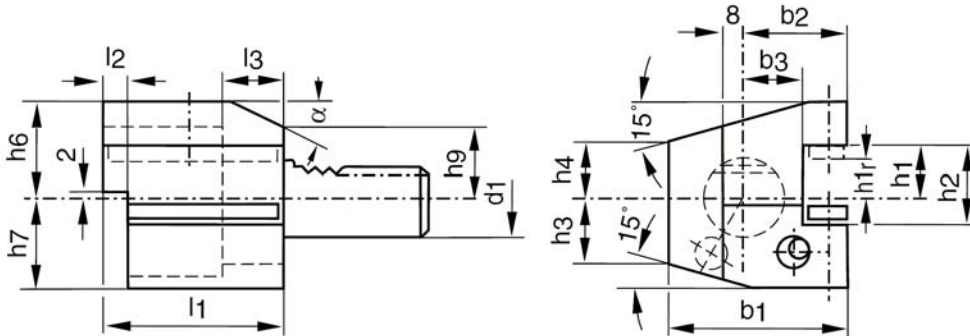

Bezeichnung <i>designation</i>	Ident-Nr. <i>Ident-No.</i>	d ₁	b ₁	b ₂	b ₃ ^{+0,5}	h ₁ /h _{1r}	h ₂	h ₃	h ₄	h ₆	h ₇	h ₉	l ₁	l ₂	l ₃	α
C3 - 16 x 12	114029	16	43	24	13	12	17	15	15	22	20		44	5	20	30°
C3 - 20 x 16	114028	20	52	27	13	16/12	22	19	19	30	25	23	55	7	30	30°
C3 - 25 x 16	114026	25	58	33	19	16/12	22	22,5	22,5	30	25	25	55	7	30	30°
C3 - 30 x 20	114025	30	70	35	17	20/16	29	26	22	38	35	28	70	10	30	25°
C3 - 40 x 25	114024	40	85	42,5	20,5	25/20	34	35	30	48	42,5		85	12,5	30	
C3 - 50 x 32	114023	50	100	50	25,5	32/25	41	42	35	60	50		100	16	40	
C3 - 60 x 32	114022	60	125	62,5	32,5	32/25	41	46	42,5	62,5	62,5		125	16	40	

Werkzeughalter-Längsaufnahme, Überkopf DIN 69 880 Teil 4 Form C4 links

Turning Tool Holder for Square Tool, Overhead DIN 69 880 Part 4 Form C4 left hand

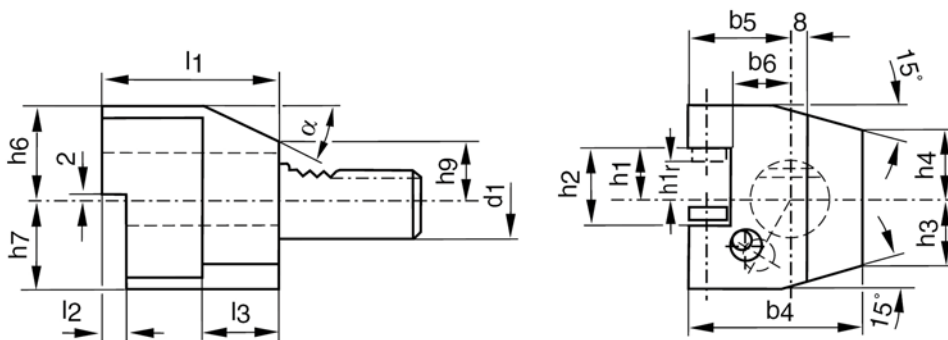

Bezeichnung <i>designation</i>	Ident-Nr. <i>Ident-No.</i>	d ₁	b ₄	b ₅	b ₆ ^{+0,5}	h ₁ /h _{1r}	h ₂	h ₃	h ₄	h ₆	h ₇	h ₉	l ₁	l ₂	l ₃	α
C4 - 16 x 12	114021	16	43	24	13	12	17	15	15	22	20		44	5	20	30°
C4 - 20 x 16	114020	20	65	40	26	16/12	22	19	19	30	25	23	50		30	30°
C4 - 25 x 16	114019	25	58	33	19	16/12	22	22,5	22,5	30	25	25	55	7	20	30°
C4 - 30 x 20	114018	30	76	41	23	20/16	29	26	22	38	35	28	70	10	30	25°
C4 - 40 x 25	114017	40	90	47,5	25,5	25/20	34	35	30	48	42,5		85	12,5	30	
C4 - 50 x 32	114016	50	105	55	30,5	32/25	41	42	35	60	50		100	16	40	
C4 - 60 x 32	114015	60	125	62,5	32,5	32/25	41	46	42,5	62,5	62,5		125	16	40	

Werkzeugaufnahme-Mehrfachaufnahme DIN 69 880 Teil 5 Form D1

Multi Purpose Square Tool Holder DIN 69 880 Part 5 Form D1

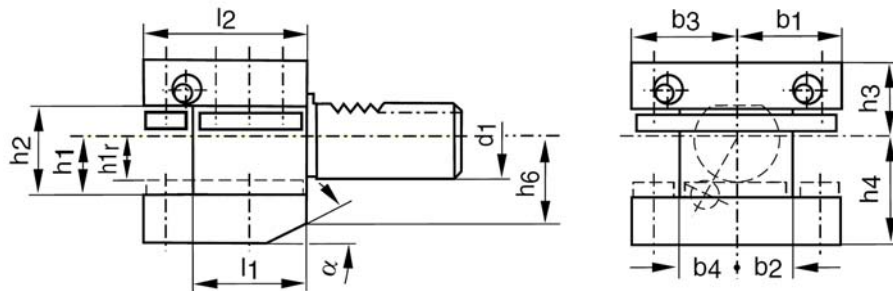

Bezeichnung designation	Ident-Nr. Ident-No.	d ₁	h ₁ /h _{1r}	b ₁	b ₂ ^{+0,5}	b ₃	b ₄ ^{+0,5}	h ₂	h ₃	h ₄	h ₆	l ₁ ^{+0,5}	l ₂	α
D1 - 25 x 16	114014	25	16/12	33	19	33	19	22	25	30	25	34	48	30°
D1 - 30 x 20	114013	30	20/16	35	17	41	23	29	28	38	30	42	60	25°
D1 - 40 x 25	114012	40	25/20	42,5	20,5	47,5	25,5	34	32,5	48		50	72	
D1 - 50 x 32	114011	50	32/25	50	25,5	55	30,5	41	35	60		60	85	
D1 - 60 x 32	114010	60	32/25	57,5	32,5	57,5	32,5	41	42,5	62,5		85	110	

Werkzeugaufnahme-Mehrfachaufnahme Überkopf DIN 69 880 Teil 5 Form D2

Multi Purpose Square Tool Holder Overhead DIN 69 880 Part 5 Form D2

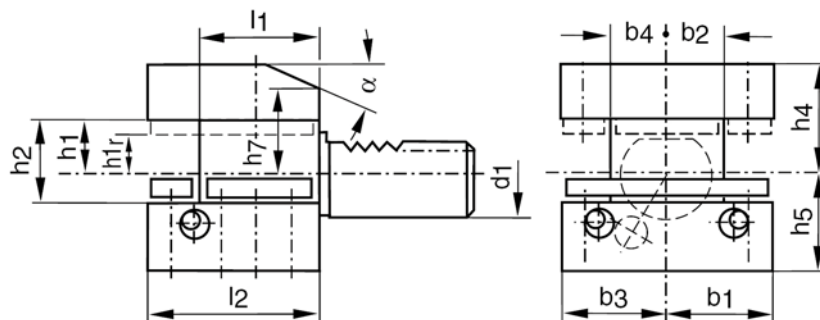

Bezeichnung designation	Ident-Nr. Ident-No.	d ₁	h ₁ /h _{1r}	b ₁	b ₂ ^{+0,5}	b ₃	b ₄ ^{+0,5}	h ₂	h ₄	h ₅	h ₇	l ₁ ^{+0,5}	l ₂	α
D2 - 25 x 16	114009	25	16/12	33	19	33	19	22	30	25	25	34	48	30°
D2 - 30 x 20	114008	30	20/16	35	17	41	23	29	38	35	28	42	60	30°
D2 - 40 x 25	114007	40	25/20	42,5	20,5	47,5	25,5	34	48	42,5		50	72	
D2 - 50 x 32	114006	50	32/25	50	25,5	55	30,5	41	60	50		60	85	
D2 - 60 x 32	114005	60	32/25	57,5	32,5	57,5	32,5	41	62,5	62,5		85	110	

Zylinderaufnahme DIN 69 880 Teil 6 Form E2 für Drehwerkzeuge mit Zylinderschaft

Side Lock Adaptor DIN 69 880 Part 6 Form E2 for turning-tools with cylindrical shaft

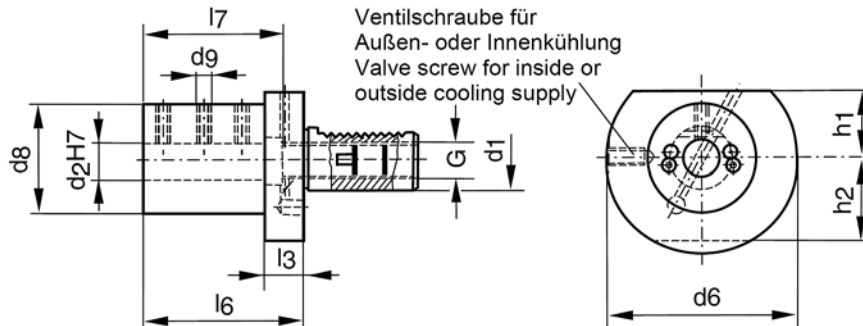

Bezeichnung designation	Ident-Nr. Ident-No.	d ₁	d ₂ ¹⁾	d ₆	d ₈	d ₉	h ₁	h ₂	l ₃	l ₆	l ₇	G
E2 - 16 x 6	114625	16	6	40	32	M6	18	18	13	44	34	M8x1
E2 - 16 x 8	114004	16	8	40	32	M6	18	18	13	44	34	M8x1
E2 - 16 x 10	114003	16	10	40	32	M6	18	18	13	44	34	M8x1
E2 - 16 x 12	114002	16	12	40	40	M8	18	18		44	34	M8x1
E2 - 16 x 16	114001	16	16	40	40	M8	18	18		44	34	M8x1
E2 - 20 x 8	114000	20	8	50	40	M8	23	23	18	50	41	M10x1
E2 - 20 x 10	113999	20	10	50	40	M8	23	23	18	50	41	M10x1
E2 - 20 x 12	113998	20	12	50	40	M8	23	23	18	50	41	M10x1
E2 - 20 x 16	113997	20	16	50	40	M8	23	23	18	50	41	M10x1
E2 - 20 x 20	113996	20	20	50	50	M8	23	23		50	41	M10x1
E2 - 20 x 25	113995	20	25	50	50	M8	23	23		60	51	M10x1
E2 - 25 x 8	113994	25	8	58	40	M8	25	25	18	50	41	M14x1,5
E2 - 25 x 10	113993	25	10	58	40	M8	25	25	18	50	41	M14x1,5
E2 - 25 x 12	113992	25	12	58	40	M8	25	25	18	50	41	M14x1,5
E2 - 25 x 16	113991	25	16	58	40	M8	25	25	18	50	41	M14x1,5
E2 - 25 x 20	113990	25	20	58	58	M8	25	25		50	41	M14x1,5
E2 - 25 x 25	113989	25	25	58	58	M8	25	25		60	51	M14x1,5
E2 - 30 x 8	113988	30	8	68	55	M8	28	30	22	60	51	M18x1,5
E2 - 30 x 10	113987	30	10	68	55	M8	28	30	22	60	51	M18x1,5
E2 - 30 x 12	113986	30	12	68	55	M8	28	30	22	60	51	M18x1,5
E2 - 30 x 16	113985	30	16	68	55	M8	28	30	22	60	51	M18x1,5
E2 - 30 x 20	113984	30	20	68	55	M8	28	30	22	60	51	M18x1,5
E2 - 30 x 25	113983	30	25	68	55	M8	28	30	22	60	51	M18x1,5
E2 - 30 x 32	113982	30	32	68	68	M8	28	30		75	61	M18x1,5
E2 - 40 x 8	113981	40	8	83	55	M8	32,5		22	75	61	M22x1,5
E2 - 40 x 10	113980	40	10	83	55	M8	32,5		22	75	61	M22x1,5
E2 - 40 x 12	113979	40	12	83	55	M8	32,5		22	75	61	M22x1,5
E2 - 40 x 16	113978	40	16	83	55	M10	32,5		22	75	61	M22x1,5
E2 - 40 x 20	113977	40	20	83	55	M10	32,5		22	75	61	M22x1,5
E2 - 40 x 25	113976	40	25	83	55	M10	32,5		22	75	61	M22x1,5
E2 - 40 x 32	113975	40	32	83	83	M10	32,5			75	61	M22x1,5
E2 - 40 x 40	113974	40	40	83	83	M10	32,5			90	76	M22x1,5
E2 - 50 x 12	113973	50	12	98	68	M12	35		30	90	76	M28x1,5
E2 - 50 x 16	113972	50	16	98	68	M12	35		30	90	76	M28x1,5
E2 - 50 x 20	113971	50	20	98	68	M12	35		30	90	76	M28x1,5
E2 - 50 x 25	113970	50	25	98	68	M12	35		30	90	76	M28x1,5
E2 - 50 x 32	113969	50	32	98	68	M12	35		30	90	76	M28x1,5
E2 - 50 x 40	113968	50	40	98	98	M12	35			90	76	M28x1,5
E2 - 50 x 50	113967	50	50	98	98	M12	35			100	86	M28x1,5
E2 - 60 x 16	113966	60	16	123	68	M12	42,5		30	90	76	M42x1,5
E2 - 60 x 20	113965	60	20	123	68	M12	42,5		30	90	76	M42x1,5
E2 - 60 x 25	113964	60	25	123	68	M12	42,5		30	90	76	M42x1,5
E2 - 60 x 32	113963	60	32	123	68	M12	42,5		30	90	76	M42x1,5
E2 - 60 x 40	113962	60	40	123	98	M12	42,5		30	90	76	M42x1,5
E2 - 60 x 50	113961	60	50	123	98	M12	42,5		30	100	86	M42x1,5

1) Zylinderaufnahmen mit weiteren d² Maßen auf Anfrage / Side Lock Adaptors with further d² measurements on request.

Werkzeughalter mit Zylinderschaft

DIN 69 880 Form E1 für Werkzeuge mit innerer Kühlschmierstoffzuführung

Toolholder with Cylindrical Shaft DIN 69 880 Form E1 for tools with inner cooling systems

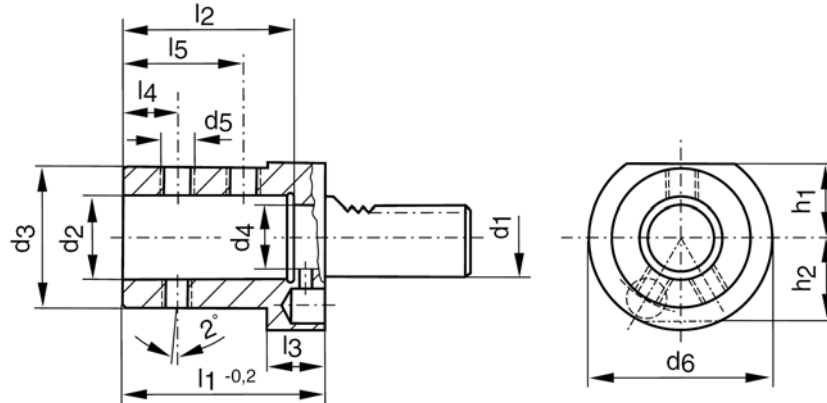

Bezeichnung <i>designation</i>	Ident-Nr. <i>Ident-No.</i>	d ₁	d ₂	d ₃	d ₄	d ₅	d ₆	h ₁	h ₂	l ₁	l ₂	l ₃	l ₄	l ₅
			H6							0-0,2				
E1 - 20 x 16	113641	20	16	36	12	M10x1	50	23	23	67	54	18	15	35
E1 - 20 x 20	114120	20	20	40	12	M10x1	50	23	23	67	54	18	15	35
E1 - 20 x 25	114122	20	25	45	17	M12x1	50	23	23	71	59	18	17	40
E1 - 25 x 16	114124	25	16	36	12	M10x1	58	25	25	67	54	18	15	35
E1 - 25 x 20	114126	25	20	40	12	M10x1	58	25	25	67	54	18	15	35
E1 - 25 x 25	114128	25	25	45	17	M12x1	58	25	25	71	59	18	17	40
E1 - 30 x 16	114130	30	16	36	12	M10x1	68	28	30	67	54	22	15	35
E1 - 30 x 20	114132	30	20	40	12	M10x1	68	28	30	67	54	22	15	35
E1 - 30 x 25	114133	30	25	45	17	M12x1	68	28	30	71	59	22	17	40
E1 - 30 x 32	114135	30	32	52	24	M12x1	68	28	30	75	63	22	20	44
E1 - 30 x 40	114137	30	40	65	32	M16x1	68	28	30	90	73	22	22	50
E1 - 40 x 16	114139	40	16	36	12	M10x1	83	32,5		67	54	22	15	35
E1 - 40 x 20	114141	40	20	40	12	M10x1	83	32,5		67	54	22	15	35
E1 - 40 x 25	114143	40	25	45	17	M12x1	83	32,5		75	59	22	17	40
E1 - 40 x 32	114145	40	32	52	24	M12x1	83	32,5		75	63	22	20	44
E1 - 40 x 40	114147	40	40	64,5	32	M16x1	83	32,5		90	73	22	22	50
E1 - 40 x 50	114149	40	50	75	32	M16x1	83	32,5		100	83	30	24	60
E1 - 50 x 20	114151	50	20	40	12	M10x1	98	35		67	54	30	15	35
E1 - 50 x 25	114153	50	25	45	17	M12x1	98	35		80	59	30	17	40
E1 - 50 x 32	114155	50	32	52	24	M12x1	98	35		80	63	30	20	44
E1 - 50 x 40	114157	50	40	65	32	M16x1	98	35		90	73	30	22	50
E1 - 50 x 50	114159	50	50	75	42	M16x1	98	35		100	83	30	24	60
E1 - 60 x 20	114117	60	20	40	12	M10x1	123	42,5		80	54	30	15	35
E1 - 60 x 25	114160	60	25	45	17	M12x1	123	42,5		80	59	30	17	40
E1 - 60 x 32	114161	60	32	52	24	M12x1	123	42,5		80	63	30	20	44
E1 - 60 x 40	114162	60	40	65	32	M16x1	123	42,5		90	73	30	22	50
E1 - 60 x 50	114163	60	50	75	42	M16x1	123	42,5		100	83	30	24	60

Reduzierhülse für Werkzeuge mit Zylinderschaft

Reducing Sleeve for tools with cylindrical shaft

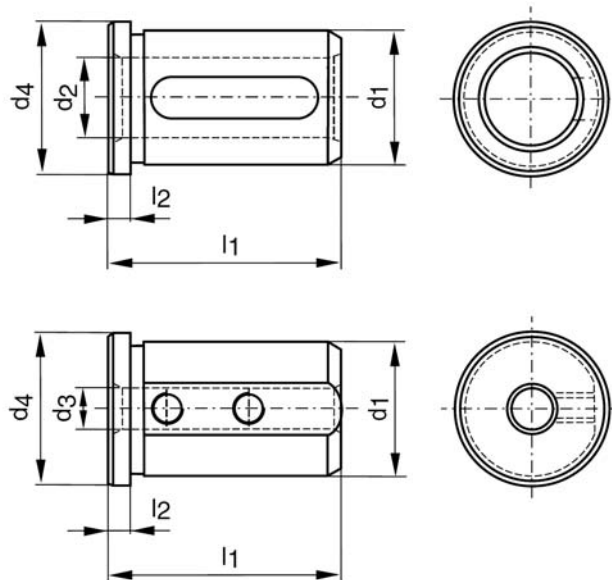

Ident-Nr. <i>Ident-No.</i>	d ₁	d ₂ ¹⁾	d ₃	d ₄	l ₁	l ₂
100237	25		6	29	50	4
100238	25		8	29	50	4
100239	25		10	29	50	4
100240	25		12	29	50	4
100241	25	16		29	50	4
100242	25	20		29	50	4
100243	32		6	36	58	5
100244	32		8	36	58	5
100245	32		10	36	58	5
100246	32		12	36	58	5
100247	32	16		36	58	5
100248	32	20		36	58	5
100249	32	25		36	58	5
107650	40		8	44	58	5
107651	40		10	44	58	5
107652	40		12	44	58	5
107653	40	16		44	58	5
107654	40	20		44	58	5
107655	40	25		44	58	5
107656	40	32		44	58	5
107657	50		12	54	75	5
107658	50	16		54	75	5
107659	50	20		54	75	5
107660	50	25		54	75	5
107661	50	32		54	75	5
107662	50	40		54	75	5

1) Reduzierhülse mit weiteren d₂ Maßen auf Anfrage
Reducing sleeve d₂ measurement on request

Werkzeughalter mit Zylinderschaft DIN 69 880 Form E3/E4 mit Zylinderaufnahme durch Spannzange
Collet Chuck DIN 69 880 Form E3/E4 with cylindrical adaption by collet

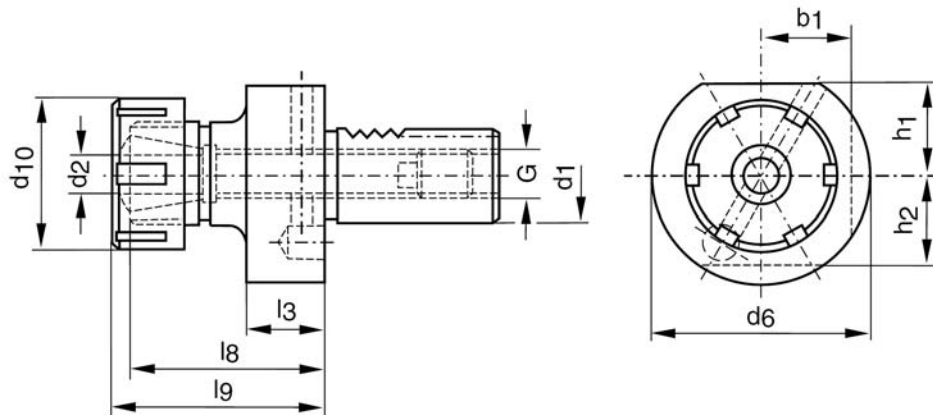

Bezeichnung													passende Spannzange Collet type
designation	Ident-Nr. Ident-No.	d ₁	d ₂	d ₆	d ₁₀	b ₁	l ₃	l ₈	l ₉	h ₁	h ₂	G	
Form E4													
E4 - 16 x 16	113872	16	0,5 - 10	40	28		13	30	40	18	18	M8x1	426E
E4 - 16 x 20	113873	16	1 - 13	40	35		13	32,5	44	18	18	M8x1	428E
E4 - 20 x 16	113874	20	0,5 - 10	50	28		18	30	40	23	23	M10x1	426E
E4 - 20 x 25	113875	20	1 - 16	50	42		18	38	50	23	23	M10x1	430E
E4 - 20 x 32	113876	20	2 - 20	50	50		18	49	62	23	23	M10x1	470E
E4 - 20 x 40	113877	20	3 - 26	50	63		22	52	66	23	23	M10x1	472E
E4 - 25 x 25	113878	25	1 - 16	58	42		18	45	57	25	25	M14x1,5	430E
E4 - 25 x 32	113879	25	2 - 20	58	50		18	49	62	25	25	M14x1,5	470E
E4 - 30 x 25	113880	30	1 - 16	68	42	30	22	45	57	28	30	M18x1,5	430E
E4 - 30 x 32	113881	30	2 - 20	68	50	30	22	49	62	28	30	M18x1,5	470E
E4 - 30 x 40	113882	30	3 - 26	68	63	30	22	56	70	28	30	M18x1,5	472E
E4 - 40 x 25	113883	40	1 - 16	83	42		22	50	62	32,5		M22x1,5	430E
E4 - 40 x 32	113884	40	2 - 20	83	50		22	49	62	32,5		M22x1,5	470E
E4 - 40 x 40	113885	40	3 - 26	83	63		22	61	75	32,5		M22x1,5	472E
E4 - 50 x 40	113886	50	3 - 26	98	63	30	61	75	35			M28x1,5	472E
E4 - 60 x 40	113887	60	3 - 26	123	63	30	61	75	42,5			M42x1,5	472E
Form E3													
E3 - 20 x 16	113861	20	1,5 - 16	50	43		18	42	57	23	23	M10x1	415E
E3 - 25 x 16	113862	25	1,5 - 16	58	43		18	42	57	25	25	M14x1,5	415E
E3 - 30 x 16	113863	30	1,5 - 16	68	43	30	22	42	57	28	30	M18x1,5	415E
E3 - 30 x 25	113864	30	1,5 - 25	68	60	30	22	59	75	28	30	M18x1,5	462E
E3 - 40 x 25	113866	40	1,5 - 25	83	60		22	59	75	32,5		M22x1,5	462E
E3 - 40 x 32	113867	40	3,5 - 32	83	72		22	73	90	32,5		M22x1,5	467E
E3 - 50 x 25	113868	50	1,5 - 25	98	60	30	59	75	35			M28x1,5	462E
E3 - 50 x 32	113869	50	3,5 - 32	98	72	30	73	90	35			M28x1,5	467E
E3 - 60 x 32	113870	60	3,5 - 32	123	72	30	73	90	42,5			M42x1,5	467E
E3 - 60 x 40	113871	60	9,5 - 40	123	85	30	82	100	42,5			M42x1,5	468E

Spannzange Bezeichnung nach DIN 6499 Form **B** (Rundlauf-toleranz Klasse 2)

Collet acc. to DIN 6499 Form **B** (run out tolerance class 2)

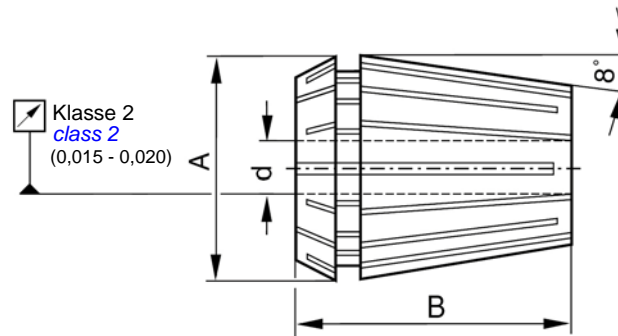

Größe/Size	4008E Form B 11	424E Form B 12	426E Form B 16	428E Form B 20	430E Form B 25	470E Form B 32	472E Form B 40	477E Form B 50
	A=11,5; B=18	A=11,8; B=19,5	A=17; B=27,5	A=21; B=31,5	A=26; B=34	A=33; B=40	A=41; B=46	A=52; B=60
Satz-/Set Ident-Nr.	118254	118255	118256	118257	118244	118258	118259	118260
Ø d	Ident-Nr.	Ident-Nr.	Ident-Nr.	Ident-Nr.	Ident-Nr.	Ident-Nr.	Ident-Nr.	Ident-Nr.
1,0	115019	114177	115033					
1,5	115020	114178						
2,0	115021	114179	115034	115043	115055			
2,5	115022	114180						
3,0	115023	114181	115035	115044	115056	115070		
3,5	115024							
4,0	115025	114182	115036	115045	115057	115071	115088	
4,5	115026							
5,0	115027	114186	115037	115046	115058	115072	115089	
5,5	115028							
6,0	115029	114187	115038	115047	115059	115073	115090	
6,5	115030							
7,0	115031	114188	115039	115048	115060	115074	115091	
7,5								
8,0			115040	115049	115061	115075	115092	
8,5								
9,0			115041	115050	115062	115076	115093	
9,5								
10,0			115042	115051	115063	115077	115094	
10,5								
11,0				115052	115064	115078	115095	
11,5								
12,0				115053	115065	115079	115096	115111
12,5								
13,0				115054	115066	115080	115097	
13,5								
14,0					115067	115081	115098	115112
14,5								

Größe/Size	4008E Form B 11	424E Form B 12	426E Form B 16	428E Form B 20	430E Form B 25	470E Form B 32	472E Form B 40	477E Form B 50
	A=11,5; B=18	A=11,8; B=19,5	A=17; B=27,5	A=21; B=31,5	A=26; B=34	A=33; B=40	A=41; B=46	A=52; B=60
Satz-/Set Ident-Nr.	118254	118255	118256	118257	118244	118258	118259	118260
\emptyset d ¹	Ident-Nr.	Ident-Nr.	Ident-Nr.	Ident-Nr.	Ident-Nr.	Ident-Nr.	Ident-Nr.	Ident-Nr.
15,0					115068	115082	115099	
15,5								
16,0					115069	115083	115100	115113
16,5								
17,0						115084	115101	
17,5								
18,0						115085	115102	115114
18,5								
19,0						115086	115103	
19,5								
20,0						115087	115104	115115
20,5								
21,0							115105	
21,5								
22,0							115106	115116
22,5								
23,0							115107	
23,5								
24,0							115108	115117
24,5								
25,0							115109	
25,5								
26,0							115110	115118
26,5								
27,0								
27,5								
28,0								115119
28,5								
29,0								
29,5								
30,0								115120
30,5								
31,0								
31,5								
32,0								115121
32,5								
33,0								
34,0								115122

Präzisions-Spannzange Bezeichnung nach DIN 6499 Typ GER - HP Form B (Rundlauf toleranz < 5µ)

Precision Collet acc. to DIN 6499 Typ GER - HP Form B runout tolerance < 5µ

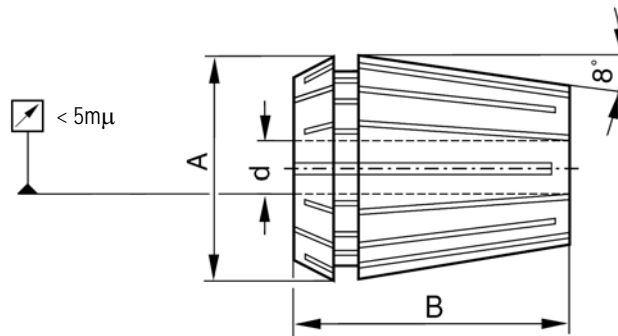

Größe/Size	16	20	25	32	40
	A=17; B=27,5	A=21; B=31,5	A=26; B=34	A=33; B=40	A=41; B=46
Ø d	Ident-Nr.	Ident-Nr.	Ident-Nr.	Ident-Nr.	Ident-Nr.
1,0	141529				
1,5					
2,0	141530	141543	141555		
2,5					
3,0	141531	141544	141556	141570	
3,5					
4,0	141532	141545	141557	141571	141588
4,5					
5,0	141533	141546	141558	141572	141589
5,5					
6,0	141534	141547	141559	141573	141590
6,5					
7,0	141535	141548	141560	141574	141591
7,5					
8,0	141536	141549	141561	141575	141592
8,5					
9,0	141537	141550	141562	141576	141593
9,5					
10,0	141538	141551	141563	141577	141594
10,5					
11,0		141552	141564	141578	141595
11,5					
12,0		141553	141565	141579	141596
12,5					
13,0		141554	141566	141580	141597
13,5					
14,0			141567	141581	141598
14,5					

Größe/Size	16	20	25	32	40
	A=17; B=27,5	A=21; B=31,5	A=26; B=34	A=33; B=40	A=41; B=46
Ø d ¹	Ident-Nr.	Ident-Nr.	Ident-Nr.	Ident-Nr.	Ident-Nr.
15,0			141568	141582	141599
15,5					
16,0			141569	141583	141600
16,5					
17,0				141584	141601
17,5					
18,0				141585	141602
18,5					
19,0				141586	141603
19,5					
20,0				141587	141604
20,5					
21,0					141605
21,5					
22,0					141606
22,5					
23,0					141607
23,5					
24,0					141608
24,5					
25,0					141609
25,5					
26,0					141610
26,5					
27,0					
27,5					
28,0					
28,5					
29,0					
29,5					
30,0					
30,5					
31,0					
31,5					
32,0					
32,5					
33,0					
34,0					

Spannzange mit Abdichtung für IK Bezeichnung nach DIN 6499 Typ GER-D ähnlich Form A (6-8 Schlitz)
 außen Geometrie nach Form B

Shink Collet with Sealing for IC acc. to DIN 6499 Typ GER-D similar Form A(6-8 slots)
 outside geometry after Form B

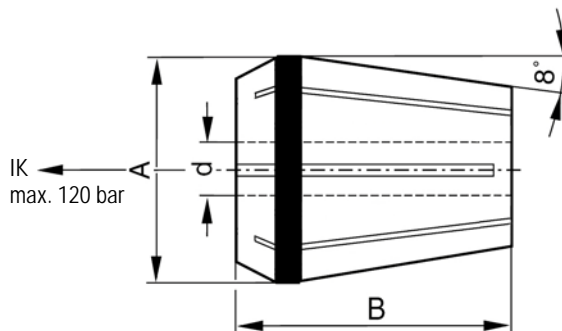

Größe/Size	16	20	25	32	40
	A=17; B=27,5	A=21; B=31,5	A=26; B=34	A=33; B=40	A=41; B=46
Ø d	Ident-Nr.	Ident-Nr.	Ident-Nr.	Ident-Nr.	Ident-Nr.
1,0					
1,5					
2,0		141442	141454		
2,5					
3,0	141433	141443	141455	141469	
3,5					
4,0	141435	141444	141456	141470	
4,5					
5,0	141436	141445	141457	141471	
5,5					
6,0	141437	141446	141458	141472	141489
6,5					
7,0	141438	141447	141459	141473	141490
7,5					
8,0	141439	141448	141460	141474	141491
8,5					
9,0	141440	141449	141461	141475	141492
9,5					
10,0	146950	141450	141462	141476	141493
10,5					
11,0		141451	141463	141477	141495
11,5					
12,0		141452	141464	141478	141496
12,5					
13,0		141453	141465	141479	141497
13,5					
14,0			141466	141480	141498
14,5					

Größe/Size	16	20	25	32	40
	A=17; B=27,5	A=21; B=31,5	A=26; B=34	A=33; B=40	A=41; B=46
Ø d ¹	Ident-Nr.	Ident-Nr.	Ident-Nr.	Ident-Nr.	Ident-Nr.
15,0			141467	141481	141499
15,5					
16,0			141468	141482	141500
16,5					
17,0				141483	141501
17,5					
18,0				141484	141502
18,5					
19,0				141485	141503
19,5					
20,0				141486	141504
20,5					
21,0					141505
21,5					
22,0					141506
22,5					
23,0					141507
23,5					
24,0					141508
24,5					
25,0					141509
25,5					
26,0					141511
26,5					
27,0					
27,5					
28,0					
28,5					
29,0					
29,5					
30,0					
30,5					
31,0					
31,5					
32,0					
32,5					
33,0					
34,0					

Spannzange für Gewindebohrer mit Längenausgleich, nach DIN 6499

Collet for Tapping for compensation acc. to DIN 6499

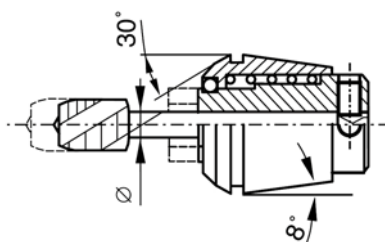

Ø	ET1-16 Ident-Nr.	ET1-20 Ident-Nr.	ET1-25 Ident-Nr.	ET1-32 Ident-Nr.	ET1-40 Ident-Nr.
1,00	ET1-16100AL 118061				
1,40	ET1-16140 118062				
1,50	ET1-16150AL 118063				
1,60	ET1-16160 118064				
1,80	ET1-16180 118065				
2,00	ET1-16200 118066				
2,20	ET1-16221 118067	ET1-20221 117628			
2,24	ET1-16224 118068	ET1-20224 117629			
2,50	ET1-16250 118069	ET1-20250 117630	ET1-25250 117646		
2,80	ET1-16280 118070	ET1-20280 117631	ET1-25280 117647		
3,00	ET1-16300 118071	ET1-20300 117632	ET1-25300 117648		
3,15	ET1-16315 118072	ET1-20315 117633	ET1-25315 117649		
3,50	ET1-16350 118073	ET1-20350 117634	ET1-25350 117650		
3,55	ET1-16355 118074	ET1-20355 117635	ET1-25355 117651		
4,00	ET1-16400 118075	ET1-20400 117636	ET1-25400 117652		
4,50	ET1-16450 118076	ET1-20450 117637	ET1-25450 117653	ET1-32450 117666	
5,00	ET1-16500 118077	ET1-20500 117638	ET1-25500 117654	ET1-32500 117667	

Ø	ET1-16	ET1-20	ET1-25	ET1-32	ET1-40
	Ident-Nr.	Ident-Nr.	Ident-Nr.	Ident-Nr.	Ident-Nr.
5,50	ET1-16550 118078	ET1-20550 117639	ET1-25550 117655	ET1-321550 117668	
5,60	ET1-16560 118079	ET1-20560 117640	ET1-25560 117656	ET1-32560 117669	
6,00	ET1-161600 118080	ET1-20600 117642	ET1-25600 117657	ET1-32600 117670	ET1-40600 117685
6,20	ET1-16620 118081	ET1-20620 117643	ET1-25620 117658	ET1-32620 117671	ET1-40620 117686
6,30	ET1-16630 118082	ET1-20630 117644	ET1-25630 117659	ET1-32630 117672	ET1-40630 117687
7,00		ET1-20700 117645	ET1-25700 117660	ET1-32700 117673	ET1-40700 117688
7,10			ET1-25710 117661	ET1-32710 117674	ET1-40710 117689
8,00			ET1-25800 117662	ET1-32800 117676	ET1-40800 117690
8,50			ET1-25850 117663	ET1-32850 117677	ET1-40850 117691
9,00			ET1-25900 117664	ET1-32900 117678	ET1-40900 117692
10,0			ET1-25100 117665	ET1-32100 117679	ET1-40100 117693
10,50				ET1-32105 117680	ET1-40105 117694
11,00				ET1-32110 117681	ET1-40110 117695
11,20				ET1-32112 117682	ET1-40112 117696
12,00				ET1-32120 117683	ET1-40120 117697
12,50				ET1-32125 117684	ET1-40125 117698
14,00					ET1-40140 117699
15,00					ET1-40150 117700
16,00					ET1-40160 117701
17,00					ET1-40170 117702
18,00					
20,00					
22,00					

Dichtscheiben für Spannmutter-System Typ Zeta mit Bohrung
Sealing Washer for Clamping Nuts System typ Zeta with bore

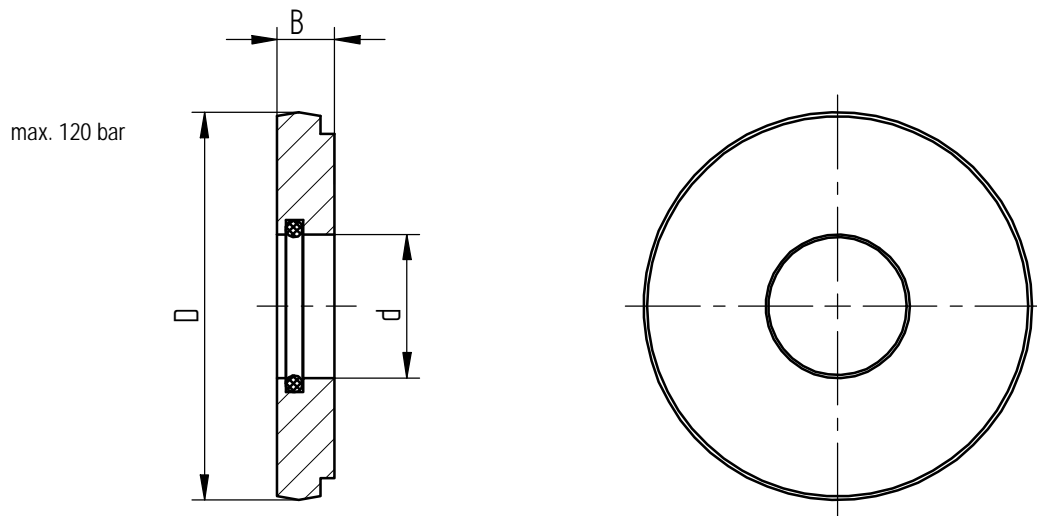

Größe/Size	16	20	25	32	40
	D=13; B=4	D=16; B=4	D=21; B=4	D=27; B=4	D=33,5; B=4
Ø d	Ident-Nr.	Ident-Nr.	Ident-Nr.	Ident-Nr.	Ident-Nr.
3,0	146931	141639	141662	141691	145310
3,5	146932	141640	141663	141692	145311
4,0	146933	141642	141664	141693	145312
4,5	146934	141643	141665	141694	145313
5,0	146935	141644	141666	141695	145314
5,5	146936	141645	141667	114696	145315
6,0	146937	141647	141668	141697	145316
6,5	146938	141648	141669	141698	145317
7,0	146939	141649	141670	141699	145318
7,5	146940	141650	141671	141700	145319
8,0	146941	141651	141672	141701	145320
8,5	146942	141652	141673	141702	145321
9,0	146943	141653	141674	141703	145322
9,5	146944	141654	141675	141704	145323
10,0	146945	141655	141676	141705	145324
10,5		141656	141677	141706	145325
11,0		141657	141678	141707	145326
11,5		141658	141679	141708	145327
12,0		141659	141680	141709	145328
12,5		141660	141682	141710	145329
13,0		141661	141683	141711	145330
13,5			141684	141712	145331
14,0			141685	141713	145332
14,5			141687	141714	145333

Größe/Size	16	20	25	32	40
	D=13; B=4	D=16; B=4	D=21; B=4	D=27; B=4	D=33,5; B=4
Ø d	Ident-Nr.	Ident-Nr.	Ident-Nr.	Ident-Nr.	Ident-Nr.
15,0			141688	141715	145334
15,5			141689	141716	145335
16,0			141690	141717	145336
16,5				141718	145337
17,0				141719	145338
17,5				141720	145339
18,0				141721	145340
18,5				141722	145341
19,0				141723	145342
19,5				145304	145343
20,0				145309	145344
20,5					145345
21,0					145346
21,5					145347
22,0					145348
22,5					145349
23,0					145350
23,5					145351
24,0					145352
24,5					145353
25,0					145354
25,5					145355
26,0					145356
26,5					
27,0					
27,5					
28,0					
28,5					
29,0					
29,5					
30,0					
30,5					
31,0					
31,5					
32,0					
32,5					
33,0					
34,0					

Spannzange Bezeichnung nach DIN 6388 Form B

Collet acc. to DIN 6388 Form B

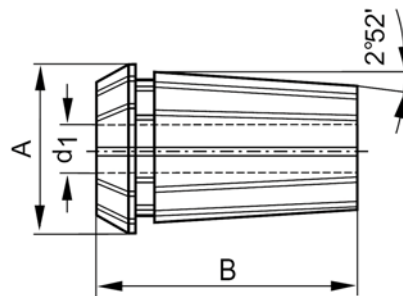

Größe/Size	025 415E	035 462E	044 467E	052 468E
	Form B 16	Form B 25	Form B 32	Form B 40
	A=25,5; B=40	A=35,5; B=52	A=44; B=60	A=52,7; B=68
Satz-/Set Ident-Nr.	118263	118264	118265	118266
Ø d ₁	Ident-Nr.	Ident-Nr.	Ident-Nr.	Ident-Nr.
2,0	115018	115150		
2,5	115032	115151		
3,0	115123	115152		
3,5	115124	115153		
4,0	115125	115154	115197	
4,5	115126	115155	115198	
5,0	115127	115156	115199	
5,5	115128	115157	115200	
6,0	115129	115158	115201	
6,5	115130	115159	115202	
7,0	115131	115160	115203	
7,5	115132	115161	115204	
8,0	115133	115162	115205	
8,5	115134	115163	115206	
9,0	115135	115164	115207	
9,5	115136	115165	115208	
10,0	115137	115166	115209	115254
10,5	115138	115167	115210	115255
11,0	115139	115168	115211	115256
11,5	115140	115169	115212	115257
12,0	115141	115170	115213	115258
12,5	115142	115171	115214	115259
13,0	115143	115172	115215	115260
13,5	115144	115173	115216	
14,0	115145	115174	115217	115262
14,5	115146	115175	115218	115263
15,0	115147	115176	115219	115264
15,5	115148	115177	115220	115265
16,0	115149	115178	115221	115266
16,5		115179	115222	115267
17,0		115180	115223	115268
17,5		115181	115224	115269
18,0		115182	115225	115270

Größe/Size	025 415E	035 462E	044 467E	052 468E
	Form B 16	Form B 25	Form B 32	Form B 40
	A=25,5; B=40	A=35,5; B=52	A=44; B=60	A=52,7; B=68
Satz-/Set Ident-Nr.	118263	118264	118265	118266
Ø d ₁	Ident-Nr.	Ident-Nr.	Ident-Nr.	Ident-Nr.
18,5		115183	115226	115271
19,0		115184	115227	115272
19,5		115185	115228	115273
20,0		115186	115229	115274
20,5		115187	115230	115275
21,0		115188	115231	115276
21,5		115189	115232	115277
22,0		115190	115233	115278
22,5		115191	115234	115279
23,0		115192	115235	115280
23,5		115193	115236	115281
24,0		115194	115237	115282
24,5		115195	115238	115283
25,0		115196	115239	115284
25,5			115240	115285
26,0			115241	115286
26,5			115242	115287
27,0			115243	115288
27,5			115244	115289
28,0			115245	115290
28,5			115246	115291
29,0			115247	115292
29,5			115248	115293
30,0			115249	115294
30,5			115250	115295
31,0			115251	115296
31,5			115252	115297
32,0			115253	115298
32,5				115299
33,0				115300
33,5				115301
34,0				115302
34,5				115303
35,0				115304
35,5				
36,0				115305
36,5				115306
37,0				115307
37,5				115308
38,0				115309
38,5				115310
39,0				115311
39,5				115312
40,0				115313

Spannschlüssel

Key

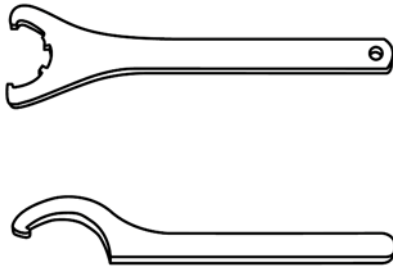

Bezeichnung <i>designation</i>	Für Spannzange <i>for Collets</i>	Ident-Nr. <i>Ident-No.</i>
225	430E	038778
232	470E	037869
240	472E	059409
250	474E	100061
416	415E	038224
425	462E	028245
432	467E	044424
440	468E	056056

Werkstoffanschlag mitlaufend, Länge verstellbar mit Schaft nach DIN 69 880

Stock Stop *revolving, adjustable length DIN 69 880*

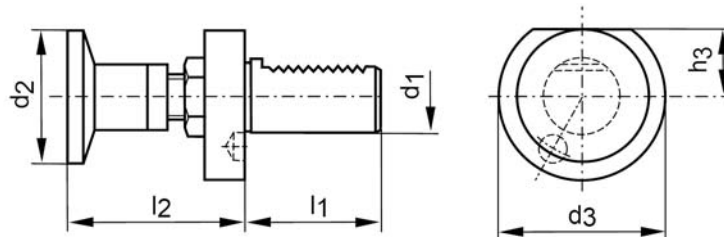

Ident-Nr. <i>Ident-No.</i>	d ₁	d ₂	d ₃	h ₃	l ₁	l ₂
116271	16	28	40	18	32	64
114214 ¹⁾	20	26	50	23	40	50-70
114215 ¹⁾	20	32	50	23	40	50-70
114216 ¹⁾	20	42	50	23	40	50-70
114217	25	26	58	25	48	50-70
114218	25	32	58	25	48	50-70
114219	25	42	58	25	48	50-70
114211	30	32	68	28	55	62-95
114212	30	42	68	28	55	62-95
114213	30	58	68	28	55	62-95
114220	40	32	83	32,5	63	62-95
114221	40	42	83	32,5	63	62-95
114222	40	58	83	32,5	63	62-95

1) Diese Abmessungen ohne Verzahnung, da technisch nicht möglich // These measurements are without serrations as this technically not possible

Kegelaufnahme DIN 69 880 Teil 7 Form **F** für Kegelschäfte mit Austreibklappen

Morse Taper Adaptor DIN 69 880 part 7 form **F** for shanks with tang

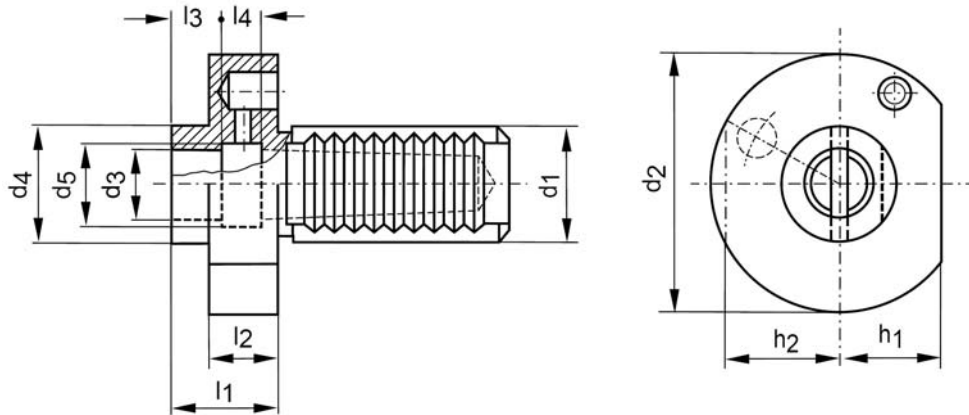

Bezeichnung <i>designation</i>	Ident-Nr. <i>Ident-No.</i>	d ₁	MK	d ₂	d ₃	d ₄	d ₅	h ₁	h ₂	l ₁	l ₂	l ₃	l ₄
F16 - MK - DK1	114600	16	1	40			13,5	18	18	43		16	12
F20 - MK - DK1	114601	20	1	50	12,065		13,5	23	23	23		16	12
F20 - MK - DK2	114602 ¹⁾	20	2	50	17,780		19,5	23	23	55		20	12
F25 - MK - DK1	114603	25	1	58	12,065		3	25	25	23		16	12
F25 - MK - DK2	114604	25	2	58	17,780		5	25	25	27		20	12
F30 - MK - DK1	114605	30	1	68	12,065		13,5	28	30	27		16	12
F30 - MK - DK2	114606	30	2	68	17,780		19,5	28	30	27		20	12
F30 - MK - DK3	114607	30	3	68	23,825		24,5	28	30	45		30	12
F40 - MK - DK1	114608	40	1	83	31,267	55	13,5	32,5		36	22	16	12
F40 - MK - DK2	114609	40	2	83	17,780	55	19,5	32,5		36	22	20	12
F40 - MK - DK3	114610	40	3	83	23,825	58	24,5	32,5		36	22	30	12
F40 - MK - DK4	114611	40	4	83	31,267	68	32	32,5		80	22	40	14
F50 - MK - DK2	114612	50	2	98	17,780	55	19,5	35		36	30	20	12
F50 - MK - DK3	114613	50	3	98	23,825	58	24,5	35		36	30	30	12
F50 - MK - DK4	114614	50	4	98	31,267	68	32	35		50	30	40	14
F60 - MK - DK2	114615	60	2	123	17,780	58	19,5	42,5		36	30	20	12
F60 - MK - DK3	114616	60	3	123	23,825	58	24,5	42,5		36	30	30	12
F60 - MK - DK4	114617	60	4	123	31,267	68	32	42,5		50	30	40	14
F60 - MK - DK5	114618	60	5	123	44,399	98	44	42,5		63	30	52	16

1) Diese Abmessungen ohne Verzahnung, da technisch nicht möglich // These measurements are without serrations as this technically not possible

Bohrstangenaufnahme mit Schaft nach DIN 69 880

Boring Bar Adaptor with shaft acc. to DIN 69 880

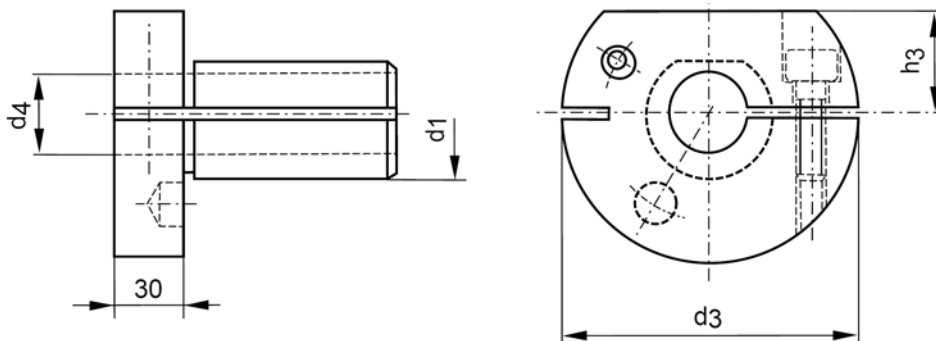

Ident-Nr. <i>Ident-No.</i>	d ₁	d ₃	d ₄	h ₃
114637	30	68	12	28
114638	30	68	16	28
114639 ¹⁾	30	68	20	28
114640	40	83	12	32,5
114935	40	83	16	32,5
114641	40	83	20	32,5
114642	40	83	25	32,5
114643 ¹⁾	40	83	32	32,5
116261	50	98	12	35
116262	50	98	16	35
116263	50	98	20	35
116264	50	98	25	35
116265	50	98	32	35
116266	60	123	16	42,5
116267	60	123	20	42,5
116268	60	123	25	42,5
116269	60	123	32	42,5
116270 ¹⁾	60	123	40	42,5

1) Diese Abmessungen ohne Verzahnung, da technisch nicht möglich. Bohrstangenaufnahme mit weitem d₄ Maßen auf Anfrage.
 These measurements are without serrations as this technically not possible.
 Further d₄ measurements on request.

Reduzierbuchse für Werkzeuge mit Zylinderschaft

Reducing Sleeve for tools with cylindrical shaft

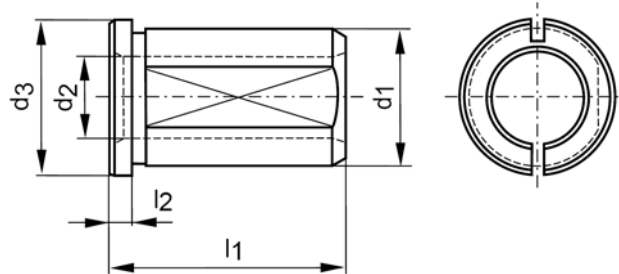

Ident-Nr. <i>Ident-No.</i>	d ₁	d ₂ 1)	d ₃	l ₁	l ₂
100223	25	6	29	40	4
100224	25	8	29	40	4
100225	25	10	29	40	4
100226	25	12	29	40	4
100227	25	15	29	40	4
100228	25	16	29	40	4
100229	25	20	29	40	4
100230	32	8	36	50	4
100231	32	10	36	50	4
100232	32	12	36	50	4
100233	32	15	36	50	4
100234	36	16	36	50	4
100235	32	20	36	50	4
100236	32	25	36	50	4
107643	40	10	44	78	4
107644	40	12	44	78	4
107645	40	15	44	78	4
107646	40	16	44	78	4
107647	40	20	44	78	4
107648	40	25	44	78	4
107649	40	32	44	78	4
107638	50	20	54	88	4
107639	50	25	54	88	4
107640	50	32	54	88	4
107641	50	40	54	88	4

1) Reduzierbuchsen mit weiteren d₂ Maßen auf Anfrage.
Reducing sleeves d₂ measurements on request.

Reduzierhülse für DIN 69 880

Reducing Sleeve for DIN 69 880

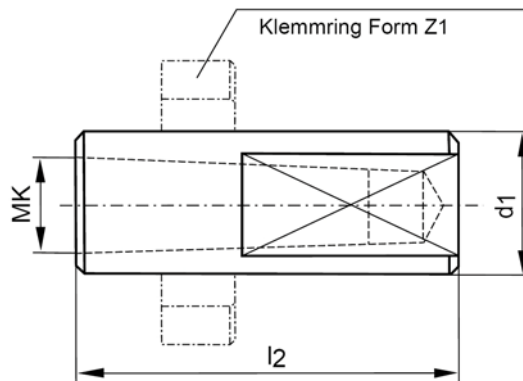

Ident-Nr. <i>Ident-No.</i>	d ₁	MK	l ₂
114192	20	1	76
114193	30	1	76
114194	30	2	71
114195	30	3	90
114196	40	1	95
114197	40	2	95
114198	40	3	95
114199	40	4	114
114200	50	2	114
114201	50	3	114
114202	50	4	114
114203	60	3	150
114204	60	4	150
114205	60	5	150

Klemmring DIN 69 880 Form Z1

Clamping Ring DIN 69 880 Form Z1

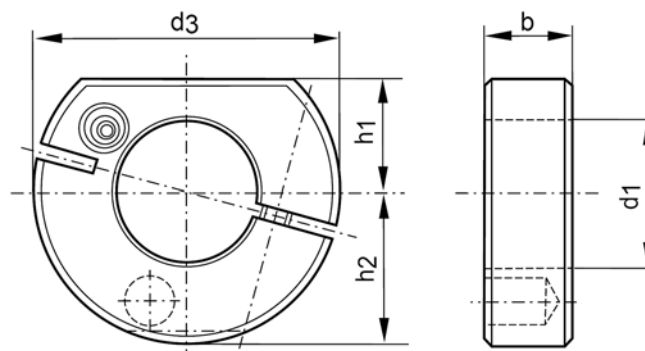

Bezeichnung <i>designation</i>	Ident-Nr. <i>Ident-No.</i>	d ₁	d ₃	b	h ₁	h ₂
Z1 - 20	114620	20	50	15	23	23
Z1 - 25	114621	25	58	16	25	25
Z1 - 30	114619	30	68	20	28	30
Z1 - 40	114622	40	83	22	32,5	
Z1 - 50	114623	50	98	30	35	
Z1 - 60	114624	60	123	30	42,5	

NC Kurzbohrfutter mit Schaft nach DIN 69 880

NC-Short Drill Chuck with shaft acc. to DIN 69 880

Typ A Spannen zentral durch Schaft	Chucking by shaft
Typ B Spannen seitlich von außen	Chucking from outside
Kühlmittelzuführung über Spritzdüsen	External cooling system

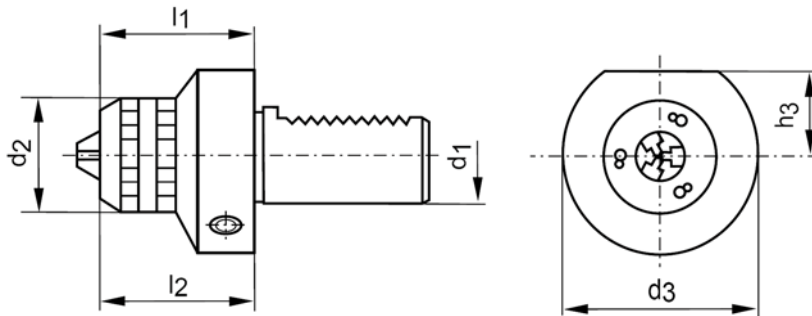

Typ Type	Ident-Nr. Ident-No.	Spannbereich Chucking Capacity	d_1	d_2	d_3	h_3	l_1	l_{2max}
A	114230	0,5 - 10	20	50	50		38	45
B	114206	0,5 - 8	16	40			60	63
B	114207	0,5 - 8	20	40		23	60	63
B	114208	0,5 - 8	25	40	28	25	60	63
B	114209	0,5 - 8	30	40	32,5	28	60	63
B	114210	0,5 - 8	40	40	32,5	32,5	65	68
B	114224	1 - 13	20	57	56		82	88
B	114225	1 - 13	25	57	58		82	88
B	114232	1 - 13	30	57	68	28	82	88
B	114237	1 - 13	40	57	83	32,5	82	91
B	114242	1 - 13	50	57	98	35	86	92
B	114231	3 - 16	30	57	68	28	82	93
B	114236	3 - 16	40	57	83	32,5	85	96
B	114241	3 - 16	50	57	98	35	86	97
B	114245	3 - 16	60	57	123	42,5	95,5	106,5

NC Kurzbohrfutter mit Schaft nach DIN 69 880

NC-Short Drill Chuck with shaft acc. to DIN 69 880

Kühlmittelezufuhr zentral
 durch das Futter und Werkzeug

Internal cooling system

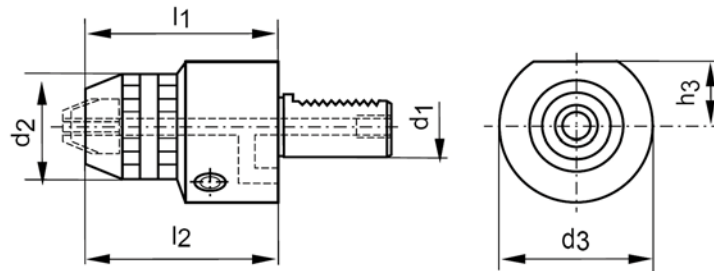

Ident-Nr. <i>Ident-No.</i>	Spannbereich Chucking Capacity	d_1	d_2	d_3	h_3	l_1	l_{2max}
114223	0,5 - 8	16	36	40	16	68	71
114226	0,5 - 8	20	36	50	23	68	71
114228	0,5 - 8	25	36	58	25	68	71
114233	0,5 - 8	30	36	68	28	68	71
114238	0,5 - 8	40	36	83	32,5	68	71
114227	1 - 13	20	50	50		90	96
114229	1 - 13	25	50	58		90	96
114235	1 - 13	30	50	68	28	90	96
114240	1 - 13	40	50	83	32,5	90	96
114244	1 - 13	50	50	98	35	90	96
114234	3 - 16	30	57	68	28	90	101
114239	3 - 16	40	57	83	32,5	90	101
114243	3 - 16	50	57	98	35	90	101
114246	3 - 16	60	57	123	42,5	93	104

Reduktion und Hinterlegscheiben für Schneideisen

Reduction and Deposit-Sheet for Cutting iron

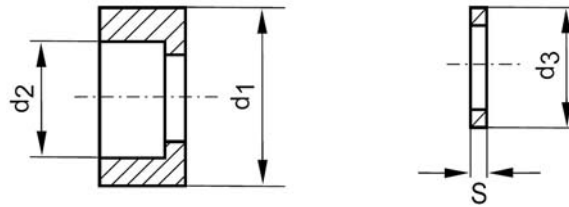

Größe/Size Maß/Dimension M Ø	R1 Ident-Nr. <i>Ident-No.</i>	R2 Ident-Nr. <i>Ident-No.</i>	R3 Ident-Nr. <i>Ident-No.</i>	R4 Ident-Nr. <i>Ident-No.</i>	H1 Ident-Nr. <i>Ident-No.</i>	H2 Ident-Nr. <i>Ident-No.</i>	H3 Ident-Nr. <i>Ident-No.</i>	H4 Ident-Nr. <i>Ident-No.</i>
Ø 25 - 20	114367							
Ø 25 - 16	114366							
Ø 38 - 30		114370						
Ø 38 - 25		114369						
Ø 38 - 20		114368						
Ø 45 - 38			114373					
Ø 45 - 30			114372					
Ø 45 - 25			114371					
Ø 55 - 45				114376				
Ø 55 - 38				114375				
Ø 55 - 30				114374				
Ø 20 x 1					114306			
Ø 38 x 2						114307		
Ø 45 x 2							114308	
Ø 55 x 3								114309

Gewindeschneidfutter mit Längenausgleich auf Druck und Zug mit Schaft nach DIN 69 880
Tapping Head with Tension and CSompression with shaft acc. to DIN 69 880

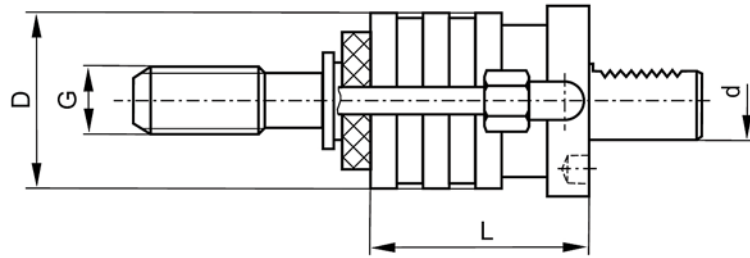

Ident-Nr. <i>Ident-No.</i>	Größe <i>Size</i>	d	D	L	G
114377	1	16	36	52	3-12
114378	1	20	36	58	3-12
114379	1	25	36	50	3-12
114380	1	30	36	62,5	3-12
114381	1	40	36	62,5	3-12
114382	1	50	36	70,5	3-12
114383	2	30	53	87	8-20
114384	2	40	53	87	8-20
114385	2	50	53	104	8-20
114386	2	60	53	104	8-20
114387	3	40	78	122	14-33
114388	3	50	78	108	14-33
114389	3	60	78	108	14-33

Schnellwechsel-
Einsätze IG
ohne Sicherheitskupplung
zur Aufnahme von
Gewindebohrer

*Quick change inserts
IG for taper*

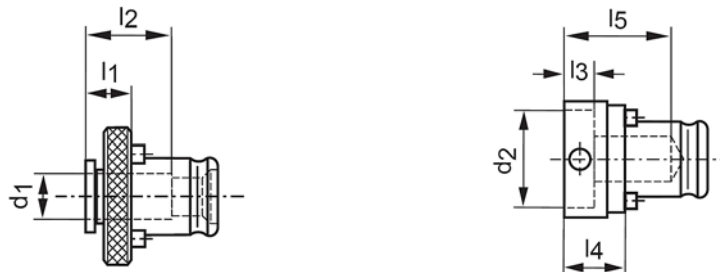

Ident-Nr. <i>Ident-No.</i>	Größe <i>Size</i>	d ₁	□	l ₁	l ₂
114390	1	2,5	2,1	7	17
114391	1	2,8	2,1	7	17
114392	1	3,15	2,5	7	17
114393	1	3,5	2,7	7	17
114394	1	3,55	2,8	7	17
114395	1	4	3	7	17
114396	1	4	3,1	7	17
114397	1	4,5	3,4	7	17
114398	1	5	4	7	17
114399	1	6	4,9	7	17
114400	1	6,3	5	7	17
114401	1	7	5,5	7	17
114402	1	8	6,2	7	17
114403	1	9	7	7	17
114404	1	10	8	7	17
114405	1	11	9	7	17

Ident-Nr.	Größe/Size	d ₁	□	l ₁	l ₂
114406	1	11,2	9	7	17
114407	2	6	4,9	11	30
114408	2	6,3	5	11	30
114409	2	7	5,5	11	30
114410	2	8	6,2	11	30
114411	2	9	7	11	30
114412	2	10	8	11	30
114413	2	11	9	11	30
114414	2	11,2	9	11	30
114415	2	12	9	11	30
114416	2	12,5	10	11	30
114417	2	14	11	11	30
114418	2	14	11,2	11	30
114419	2	16	12	11	30
114420	2	16	12,5	11	30
114421	2	18	14	11	30
114422	2	18	14,5	11	30
114423	3	11	9	14	44
114424	3	11,2	9	14	44
114425	3	12	9	14	44
114426	3	12,5	10	14	44
114427	3	14	11	14	44
114428	3	14	11,2	14	44
114429	3	16	12	14	44
114430	3	16	12,5	14	44
114431	3	18	14	14	44
114432	3	18	14,5	14	44
114433	3	20	16	14	44
114434	3	22	18	14	44
114435	3	22,4	18	14	44
114436	3	25	20	14	44
114437	3	28	22	14	44

Ident-Nr.	Größe/Size	d ₂	l ₃	l ₄	l ₅
114438	1	16	4,8	14	28
114439	1	20	4,8	14	28
114440	1	20	6,5	16	30
114441	1	25	8,5	19	33
114442	1	30	10	21	35
114443	1	38	9	20	34
114444	1	38	13	24	38
114445	2	20	4,8	20	55
114446	2	20	6,5	21,5	56
114447	2	25	8,5	23,5	55
114448	2	30	10	22	57
114449	2	38	9	21	56
114450	2	38	13	25	60
114451	2	45	13	25	60
114452	2	45	17	35	64
114453	3	30	10	30	85
114454	3	38	9	28	83
114455	3	38	13	32	87
114456	3	45	13	32	87
114457	3	45	17	36	91
114458	3	55	15	30	85
114459	3	55	20	35	90
114460	3	65	17	32	87
114461	3	65	23	38	93

Stangengreifer mit Schaft nach DIN 69 880

Bar Pick Up with shaft acc. to DIN 69 880

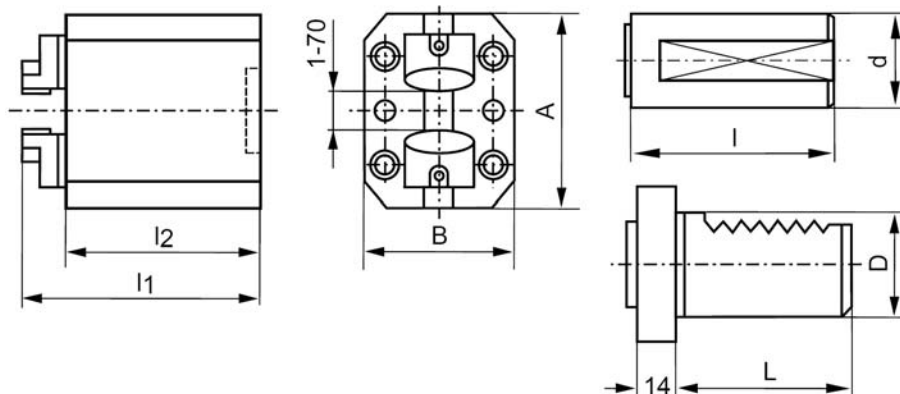

Hinweis: Stangengreifer nur in Verbindung mit Schaft bestellen

Note: Order bar up only in combination with shaft

Ident-Nr. Stangengreifer/ bar pick up	A	B	L ₁	L ₂	Ident-Nr. Schaft/ shaft	d	l	D	L
114941	50	42	54	40	114462	16	32		
					114463	20	40		
					114464	25	48		
114942	70	50	58	41	114465			30	55
					114466			40	63
					114467			50	63

Stangengreifer mit Schaft nach DIN 69 880 rechts

Bar Pick Up with shaft acc. to DIN 69 880 right hand

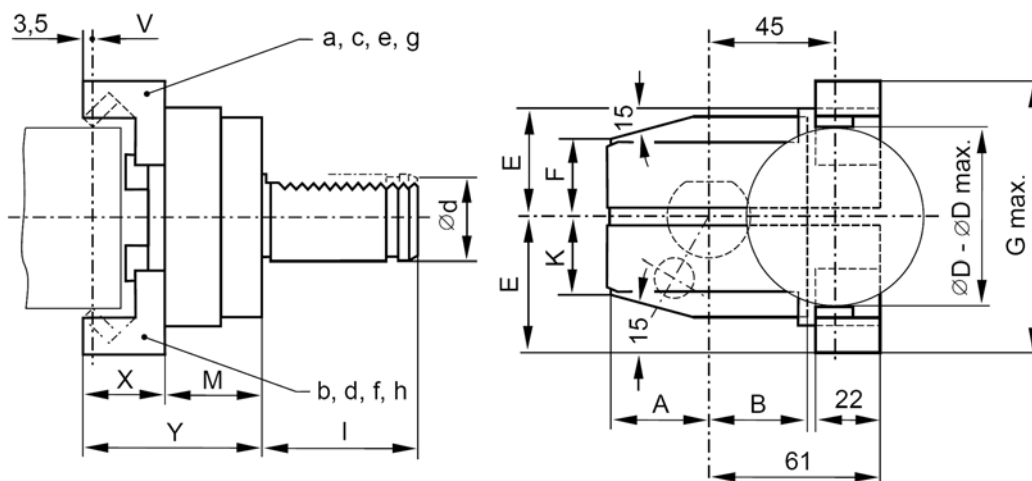

Bezeichnung designation	Ident-Nr.	d	l	A	B	E	F	K	M	D	Sonderzubehör special accessories	G	V	X	Y
41 - 0013	114468	16	32				12,5	12,5	2-22		16-32	59	20		53
41 - 1014	114469	20	40	31,5	31,	38	17	17	34	2-42		74	15	25	59
41 - 2015	114470	30	55	35	35	38	27	27	34	2-42	42-65	96	15/10	25/29	59/63
41 - 3016	114471	40	63	40	35	38	27	27	40	2-65	62-85	122	15/10	25/29	59/63
41 - 4017	114472	50	78	35	35	45	32	40	40	2-65	62-85	122	15/10	25/29	59/63

Stangengreifer mit Schaft nach DIN 69 880 links

Bar Pick Up with shaft acc. to DIN 69 880 left hand

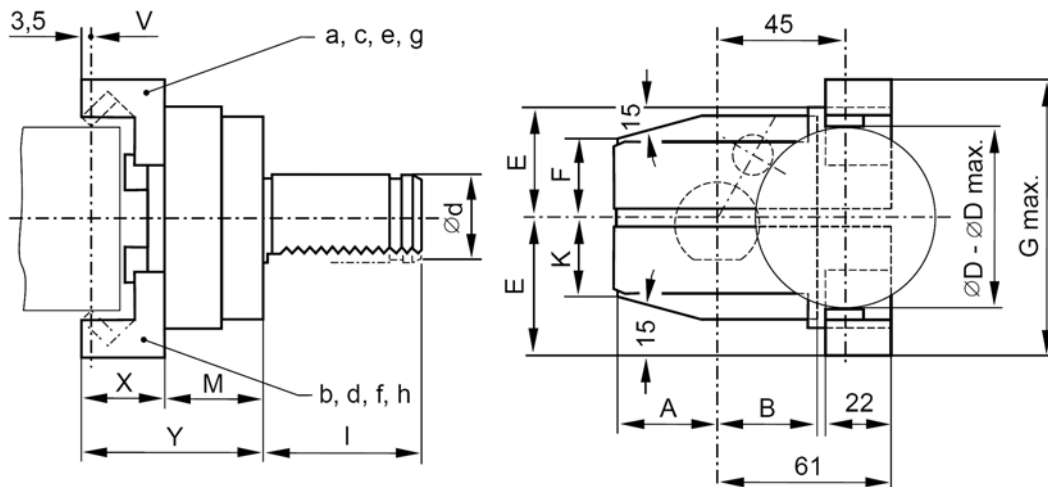

Bezeichnung <i>designation</i>	Ident-Nr. <i>Ident-No.</i>	Größe <i>Size</i>	I	A	B	E	F	K	M	D	Sonder- zubehör special accesss	G	V	X	Y
41 - 2215	114473	1	55	35	35	38	27	27	34	2-42	42-65	96	15/10	25/29	59/63
41 - 3216	114474	40	63	40	35	38	27	27	40	2-65	62-85	122	15/10	25/29	59/63

Sonderzubehör und Ersatzteile
Greifer-Aufsätze

*Special accessories and spare
parts
Pick up attachment*

Hartmetall-Platte

Hard-metal plate

Bezeichnung <i>designation</i>	Ident-Nr. <i>Ident-No.</i>	D	G	V	X	Nr.
41 - 0051	117616	16 - 36				
41 - 1150	117617	2 - 22	60	15	25	4091184
41 - 1151	117618	20 - 42	74	15	25	4091184
41 - 1152	117619	42 - 65	96	10	29	4091184
41 - 1153	117621	62 - 85	122	10	29	4091184

Verschlussstopfen wahlweise aus Stahl oder Kunststoff DIN 69 880 Form **Z2**

Plug made either from steel or plastic DIN 69 880 Form **Z2**

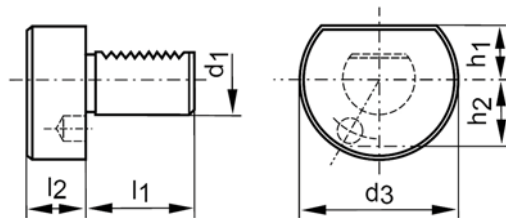

Ausführung Kunststoff / *Version plastic*

Bezeichnung <i>designation</i>	Ident-Nr. <i>Ident-No.</i>	d_1	d_3	h_1	h_2	l_1 max	l_2 max
16 K	077033	16	40	18	23	32	13
20 K/V	100097	20	50	23	23	40	16
25 K/V	088701	25	58	25	25	48	16
30 K/V	086191	30	68	28	30	55	16
40 K/V	086192	40	83	32,5		63	20
50 K/V	086193	50	98	35		78	20

Ausführung Stahl mit O-Ring / *Version steel with O-ring*

Bezeichnung <i>designation</i>	Ident-Nr. <i>Ident-No.</i>	d_1	d_3	h_1	h_2	l_1 max	l_2 max
16 S m.O-Ring	086196	16	40	18	23	32	13
20 S m.O-Ring	086197	20	50	23	23	40	16
25 S m.O-Ring	114579	25	58	25	25	48	16
30 S m.O-Ring	114577	30	68	28	30	55	16
40 S m.O-Ring	114575	40	83	32,5		63	20
50 S m.O-Ring	114573	50	98	35		78	20
60 S m.O-Ring	114571	60	123	42,5		94	20
80 S m.O-Ring	114569	80	158	55		124	20

Einrichtehalter mit Schaft nach DIN 69 880

Setting-Holder with shaft acc. to DIN 69 880

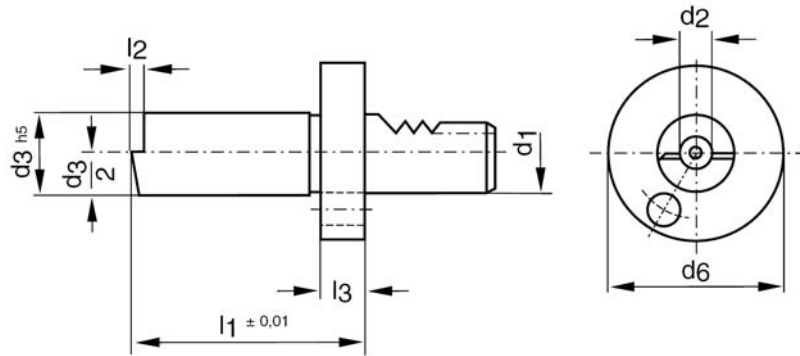

Ident-Nr.	d ₁	d ₂	d ₃	d ₆	l ₁	l ₂	l ₃
114475	16	20	30	40	100	8	15
114476	20	20	40	50	100	8	15
114477	25	20	40	58	100	8	15
114478	30	20	40	68	100	8	15
114479	40	20	40	83	100	8	15
114480	50	20	40	98	100	8	15
114481	60	20	40	123	100	8	15

Prüfdorn mit Schaft nach DIN 69 880 **und Transport / Aufbewahrungsbox**

Test Mandrel with shaft acc. to DIN 69 880 and Transport / Safe Keeping Box

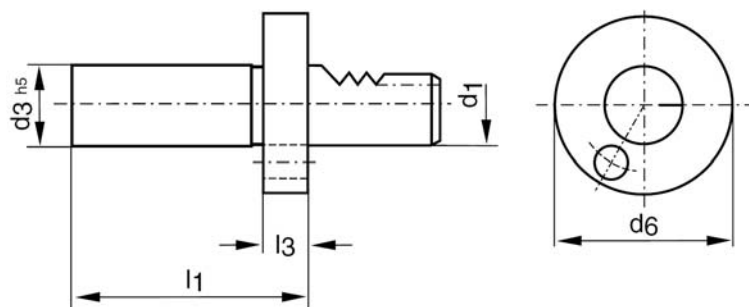

Prüfdorn <i>Test Mandrel</i>	Aufbewahrungsbox <i>Safe Keeping Box</i>	d ₁	d ₃	d ₆	l ₁	l ₃
Ident-Nr. <i>Ident-No.</i>	Ident-Nr. <i>Ident-No.</i>					
114482	147819	16	30	40	120	15
114483	147820	20	40	50	150	15
114484	147821	25	40	58	150	15
114485	147822	30	40	68	200	15
114486	147823	40	40	83	200	15
114487	147824	50	40	98	200	15
114488	147825	60	40	123	200	15
131640		80	40	158	200	30

Blockwerkzeughalter
Block Tool Holder

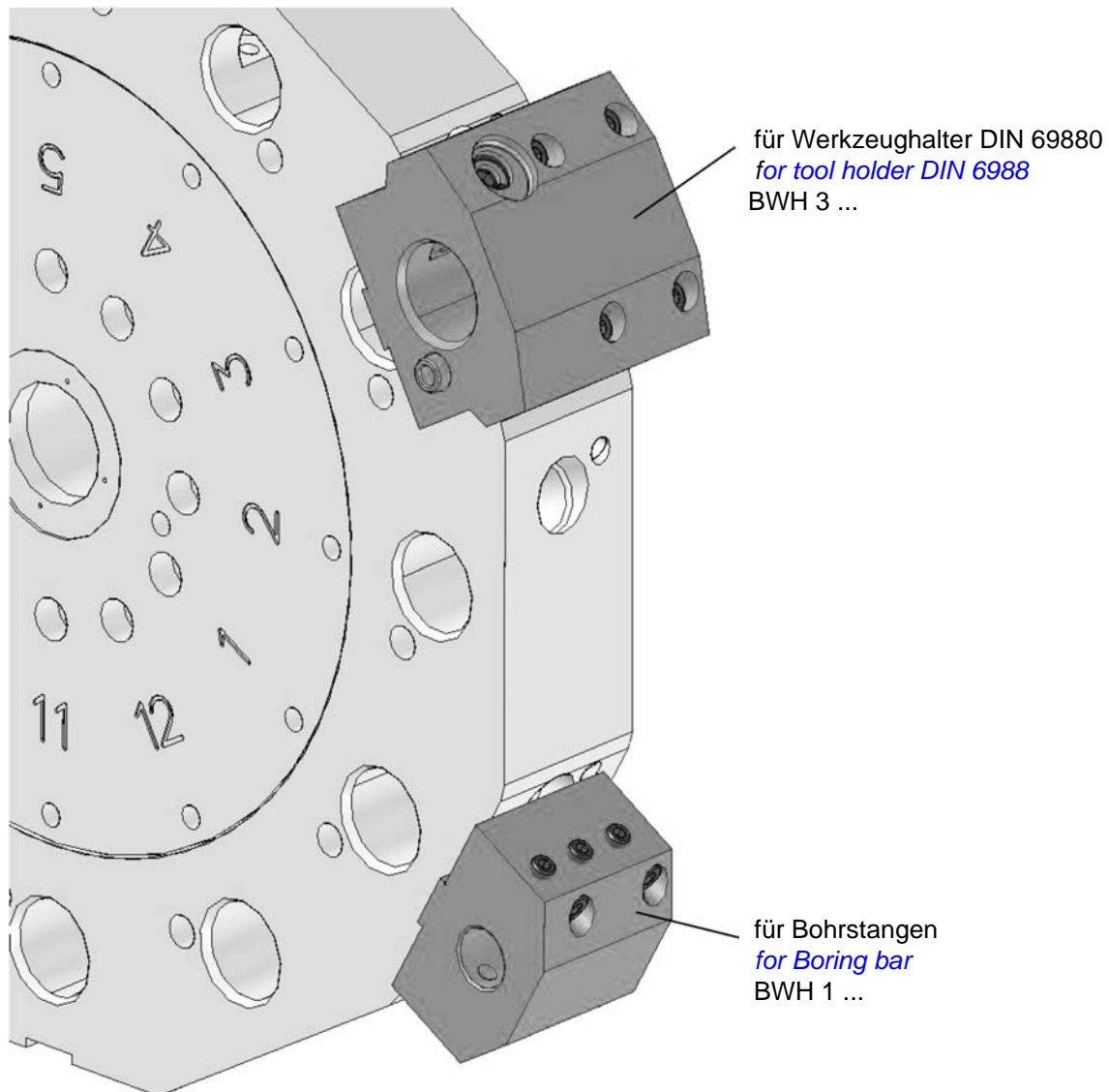

Blockwerkzeughalter für Bohrstangen Kühlschmierstoffzuführung extern / intern

Block Tool Holder for Boring Bar coolant supply external / internal

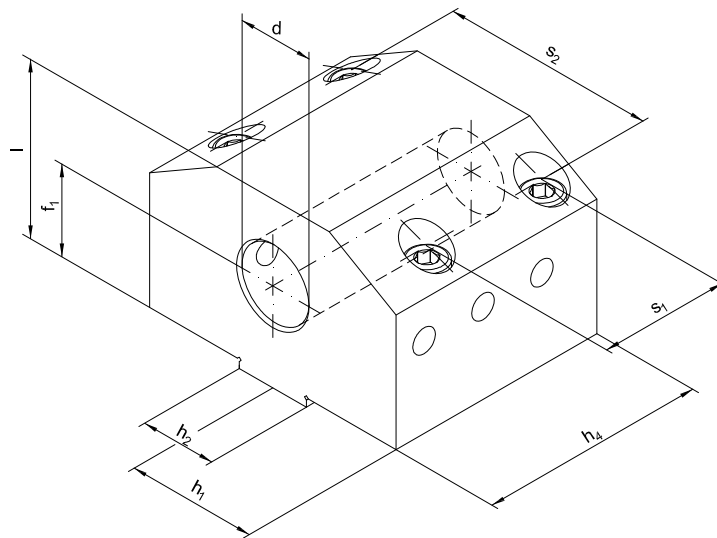

Kühlschmierstoffdruck intern 10 bar, extern 80 bar. *)intern/extern 80 bar
 coolant pressure internal 10 bar, external 80 bar. *)internal/external 80 bar

Bezeichnung <i>designation</i>	Ident-Nr. <i>Ident-No.</i>	h_2	d	f_1	l	h_1	h_4	s_1	s_2
BWH 1 20-20	131659	20	20	25	45	37	60	34	57
BWH 1 20-25	131660	20	25	25	45	37	60	34	57
BWH 1 20-32	131661	20	32	25	45	37	60	34	57
BWH 1 20-40	131663	20	40	32	57	37	60	34	57
BWH 1 25-20 *)	131664	25	20	30	55	46	75	43	71
BWH 1 25-25 *)	131665	25	25	30	55	46	75	43	71
BWH 1 25-32 *)	131666	25	32	30	55	46	75	43	71
BWH 1 25-40 *)	131667	25	40	30	55	46	75	43	71
BWH 1 25-50 *)	131668	25	50	38	70	46	75	43	71
BWH 1 32-25 *)	131669	32	25	35	70	57,5	95	57	90
BWH 1 32-32 *)	131670	32	32	35	70	57,5	95	57	90
BWH 1 32-40 *)	131671	32	40	35	70	57,5	95	57	90
BWH 1 32-50 *)	131672	32	50	35	70	57,5	95	57	90
BWH 1 32-60 *)	131673	32	60	40	80	57,5	95	57	90
BWH 1 40-32	145056	40	32	40	82	71	125	77	111
BWH 1 40-40	145058	40	40	40	82	71	125	77	111
BWH 1 40-50	145059	40	50	40	82	71	125	77	111
BWH 1 40-60	145060	40	60	40	82	71	125	77	111
BWH 1 40-80	145061	40	80	50	102	71	125	77	111

Blockwerkzeughalter für Werkzeughalter DIN 69 880

Block Tool Holder for Tool Holder DIN 69 880

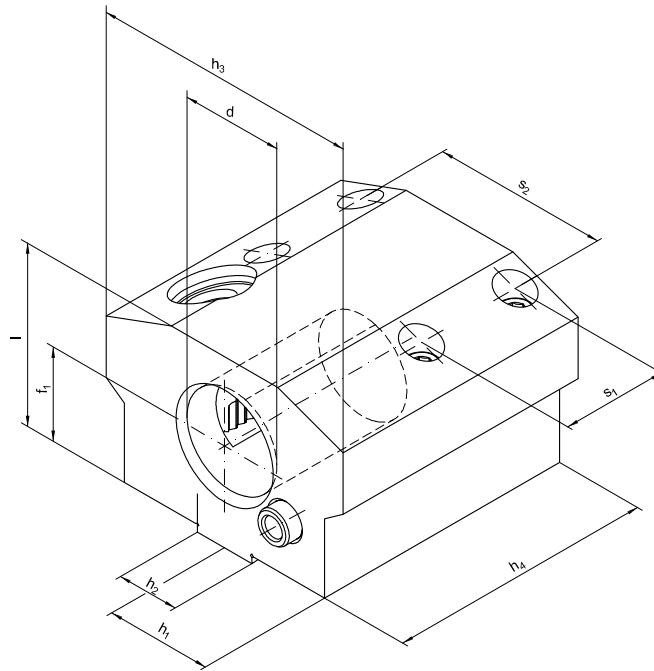

Kühlschmierstoffdruck max. 80 bar
coolant pressure max. 80 bar

Bezeichnung <i>designation</i>	Ident-Nr. <i>Ident-No.</i>	h_2	d	f_1	l	h_1	h_4	h_3	s_1	s_2
BWH 3 25-30	131649	25	30	27,5	55	46	97	97	43	71
BWH 3 25-40	131650	25	40	37,5	70	54,5	108	108	43	71
BWH 3 32-30	131651	32	30	35	67	57,5	113	113	57	90
BWH 3 32-40	131652	32	40	35	67	57,5	124	124	57	90
BWH 3 32-50	131653	32	50	35	70	57,5	126	126	57	90