

MOBILE SHELVING ASSEMBLY INSTRUCTIONS AND PACKING LIST

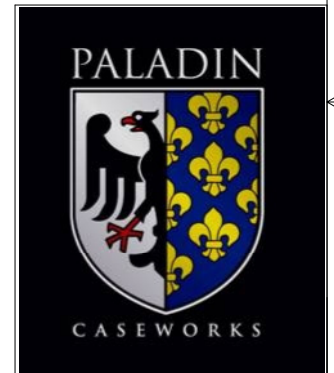
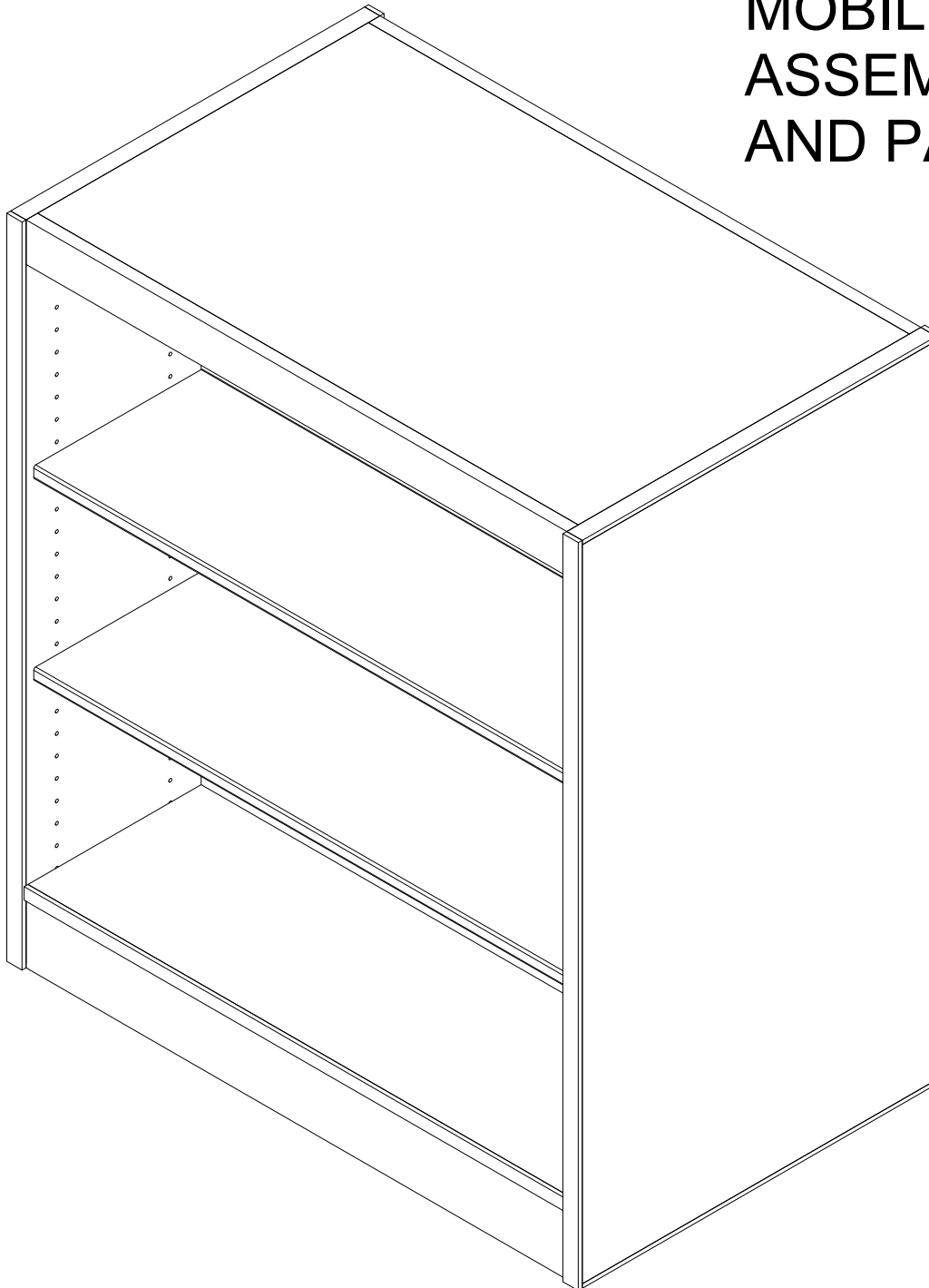
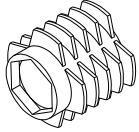
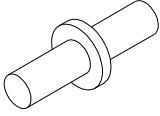
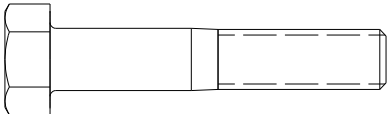
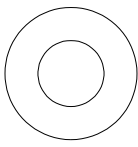
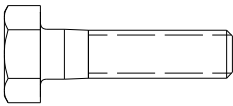
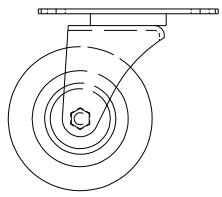

ORDER NO:	
DEALER	
PROJECT	
SIZE	SCALE
A	
DRAWN	DATE
DG	9/10/2013
DWG NO CSHF4224SMOB.iam	REV
SHEET 1 OF 3	

2
HARDWARE LIST MOBILE SHELVING

ITEM	QTY	DESCRIPTION	
1	8	INSERT 5/16-18 FACTORY INSTALLED	
2	16	SHELF PIN	
3	8	5/16-18 x 1 3/4 HEX HEAD UNC	
4	8	5/16 FLAT WASHER	
5	16	1/4-20 x 1 HEX HEAD UNC	
6	4	3" CASTER	

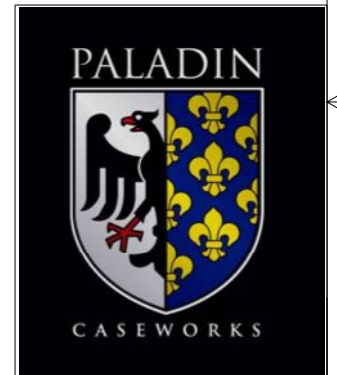

ORDER NO:	
DEALER	
PROJECT	
SIZE A	SCALE
DRAWN DG	DATE 9/10/2013
DWG NO UPRIGHT INSERT.ipt	REV
SHEET 2 OF 3	

Step One: Place left end panel on floor with groove for back facing up.

Step Two: Attach base to left hand end panel. Align grooves for back panel with grooved rail on base. Secure with hand tightened 1-3/4" hex bolt and washer through each hole in the base into the threaded insert in the end panel.

Step Three: Attach soffit to left end panel. Secure with hand tightened 1-3/4" hex bolt and washer through each hole in the base into the threaded insert in the end panel.

Step Four: Slide back into the grooves on soffit and the base rail.

Step Five: Repeat steps 2 & 3 for right hand end panel

Step Six: Attach 3" casters (qty 4) to base using 1/4-20 x 1 hex bolt into factory installed 16GA steel bracket. see figure A

Step Seven: Tighten all hex bolts with socket or wrench. Adjust base, top and end panels to straighten the units.

Step Eighth: Stand shelving unit

Step Nine: Set each adjustable shelf with four shelf pins in notches on the shelves.

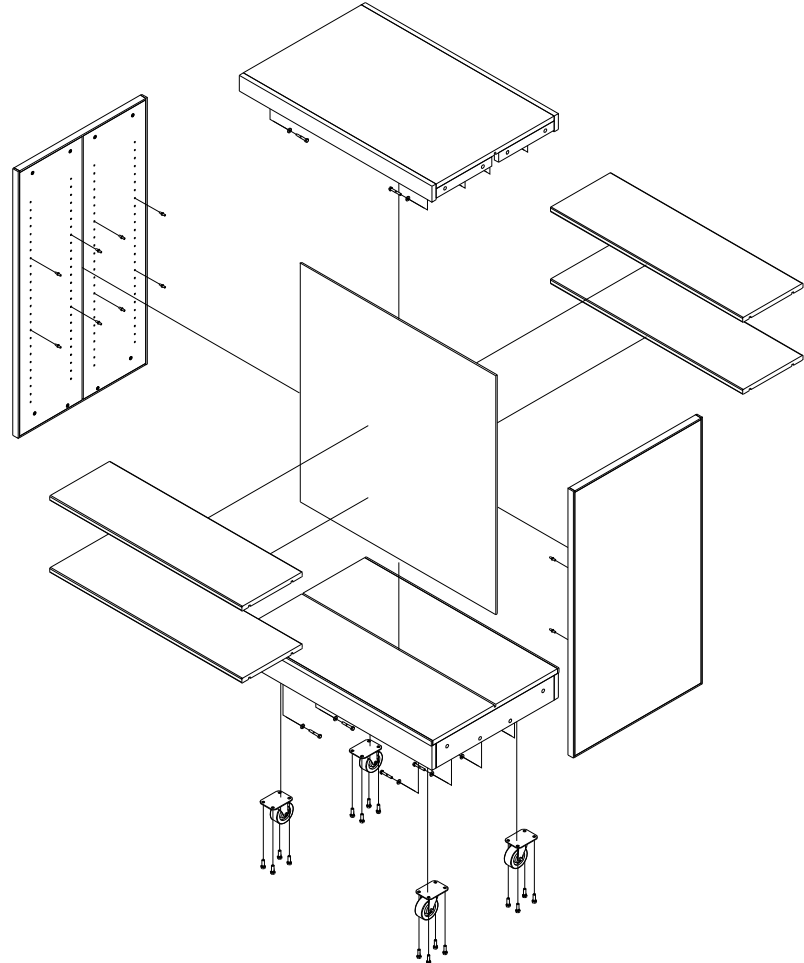
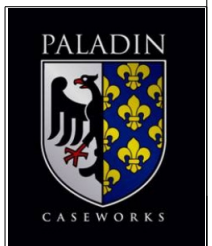
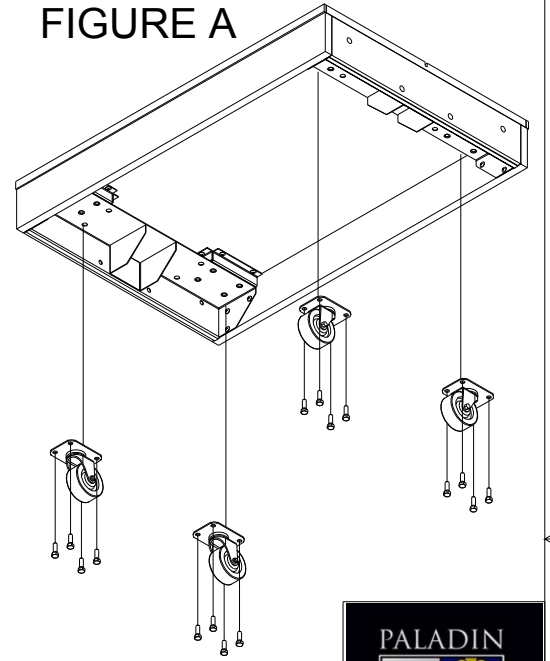

FIGURE A



ORDER NO:	
DEALER	
PROJECT	
SIZE B	SCALE
DRAWN DG	DATE 9/10/2013
DWG NO CSHF4224SMOB.lam	
SHEET 3 OF 3	