

**PRESHENT**

**SKYSTREAM 3.7**

Battery Charging Guide

3-CMLT-1385-01 REV C

For Grid-Connected and Off-Grid Systems

Installation  
Operation

## **PRESHENT Wind**

### **Congratulations on your purchase and welcome to our family!**

If you have any questions or comments, we would like to hear from you. Please call during working hours (Monday-Friday 8:00 am to 5:00 pm - Eastern Time Zone).

Our phone number is **Toll Free: 1-888-575-4880**.

For technical support, contact **Support@Preshent.com**

### **Building a Battery Charging / Battery Backup System**

Using the Skystream 3.7® wind generator, you can easily build a battery charging system or connect to an existing renewable energy system. With Skystream's AC output power design, the Skystream will install in your home's circuit breaker just as any other large home appliance, supplying your home's electrical loads. In battery based systems your home host inverter and battery will balance electrical demand. While there may be many ways to configure a system, PRESHENT Wind recommends the following most common options.

#### **Scope**

This manual provides the specialized information needed to incorporate Skystream 3.7 in either grid-connected or "off-grid" battery charging systems. As battery charging systems are often much more complex than systems using Skystream to supplement grid power, this manual does not attempt to provide detailed instructions for every possible combination of battery bank, solar panel array, diversion load, inverter, auxiliary generators, and transformers.

This manual does not contain detailed assembly and installation instructions for Skystream 3.7; refer to your Skystream Owner's Manual for that information.

#### **Introduction**

The most common application for Skystream 3.7 is as a supplement to the AC power provided by the utility grid. However, Skystream may also be successfully utilized in battery charging applications, including grid connected systems with battery backup and completely off-grid battery systems.

In addition to the basic system elements of the host inverter, Skystream and battery bank, a battery charging system may also incorporate many more elements such as diversion loads, an auxiliary generator, photovoltaic panels and charge regulators and may or may not be connected to the electrical utility grid. Battery charging systems must also be safe and may be subject to the same building code and zoning regulations as a typical Skystream grid-connected installation. As such, battery charging systems may be quite complex and must be carefully planned, taking into account immediate needs, regulations and requirements as well as future needs.

A block diagram of battery charging system incorporating many typical elements is shown in Figure 1.

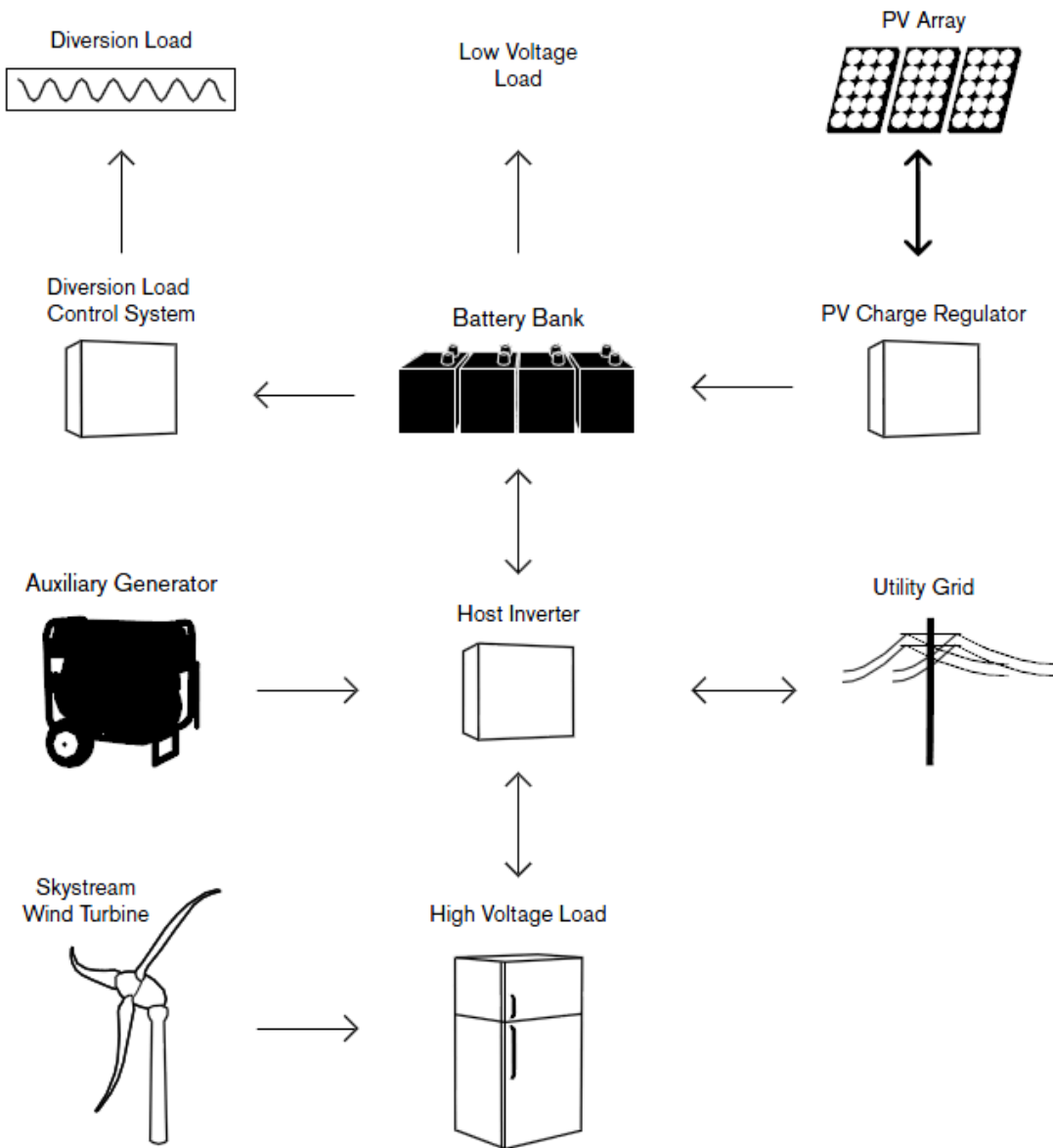

**Figure 1: Typical elements of a battery charging system**

### Theory of Operation

The integration of Skystream into a battery charging system has requirements very similar to those of grid-connected systems without batteries. In either case, Skystream supplements high voltage (AC) power supplied by another source. With grid-connected systems, Skystream supplements the utility grid while with a battery system Skystream may be supplementing power supplied to an inverter from a battery bank, an array of photovoltaic panels, an auxiliary generator or the utility grid.

As shown in Figure 1, in battery charging systems, Skystream is typically connected in parallel with what are often called the “AC Out” terminals of the host inverter along with the high voltage AC loads the inverter supports. Since the Skystream produces high voltage AC, it will directly provide electricity (as long as the wind is blowing) for the high voltage loads and thereby lessen demand from the host inverter. The inverter acts as a hub for host energy throughputs, managing DC power, high voltage loads and energy input such as from photovoltaic panels. In battery charging systems the host inverter creates a “grid-like” environment to which Skystream can synchronize and provide power.

Most inverters sold today have a form of H-bridge converter that allow flow of DC current in two directions and AC coupling that can use excess power on the AC bus for battery charging purposes. It is imperative that the “host” inverter be of a sufficient capacity to safely manage the maximum output from Skystream in the event that there is no load operating in parallel with the turbine. A regular 240 VAC split phase version of the Skystream can produce 2.5 kW continuously with peak momentary outputs over 3 kW; therefore, an inverter (or multiple inverters) with a rating over 3 kW is required. A single phase 120 VAC “battery charging” version of the Skystream 3.7 is limited to 1500 watts continuous power but can produce peak outputs of 2 kW; therefore, an inverter with a rating of 2 kW is sufficient for those applications.

**Several inverter manufacturers have provided PRESIDENT Wind with specific recommendations for which their inverters are appropriate for battery charging in connection with a Skystream 3.7. This is a partial list of compatible inverters as there may be others that will work equally well that are not listed here. Check with the manufacturer of your inverter to be certain it can support this type of operation (See Table 1).**

### **System Configurations**

The following sections present four of the most common Skystream battery charging system configurations. The best configuration for your particular application depends on many factors including: availability of existing equipment such as inverters, need for 240 volt power, wire run distance and cost.

Schematics for a number of the battery charging system configurations are presented at the end of this booklet. These schematics are provided as a guide for typical installations – they are not intended to be comprehensive installation drawings.



**IMPORTANT:** Note that the 120 volt, single phase model of Skystream MUST NOT be connected to the utility grid as it is not UL approved for this application.

Refer to Table 1 for specific inverter recommendations for each configuration.

**Table 1: Configurations and suitable inverters**

Option		A	A (Grid)	B	B (Grid)	C	C (Grid)	D
<b>Skystream 3.7 Configuration</b>		<b>120/240 Split Phase</b>	<b>120/240 Split Phase</b>	<b>120/240 Split Phase</b>	<b>120/240 Split Phase</b>	<b>120/240 Split Phase</b>	<b>120/240 Split Phase</b>	<b>120 Single Phase</b>
Grid		Not Connected	Grid-Connected	Grid-Connected	Not Connected	Not Connected	Grid-Connected	Not Connected
Transformer		Not Required	Not Required	Not Required	Not Required	120/240 Transformer	120/240 Transformer	Not Required
Inverter Type		120/240 VAC Split Phase	120/240 VAC Split Phase	(2) 120 VAC Single Phase	(2) 120 VAC Single Phase	120 VAC Single Phase	120 VAC Single Phase	120 VAC Single Phase
Inverter Manufacturer	Model							
Magnum Energy Inc.								
	MS2812				•			•
	MS4024			•	•	•	•	•
	MS4024AE	•	•					
	MS4448AE	•	•					
Outback Power Products Inc.								
	FX2012T				•			•
	FX2524T				•			•
	FX3048T				•	•		•
	VFX2812				•			•
	VFX3524				•	•		•
	VFX3648				•	•		•
	VFX3024E							
	VFX3048E							
	VFX3024W							
	VFX3048W							
	GTFX3048			•			•	
	GVFX3524			•			•	
	GVFX3648			•			•	
SMA, America Inc.								
	5048U				•	•		•
	4248U					•		•
Xantrex								
	XW	•	•					

**Option A 120/240 volt (US residential voltage) Skystream with a SINGLE 120/240 VAC inverter**

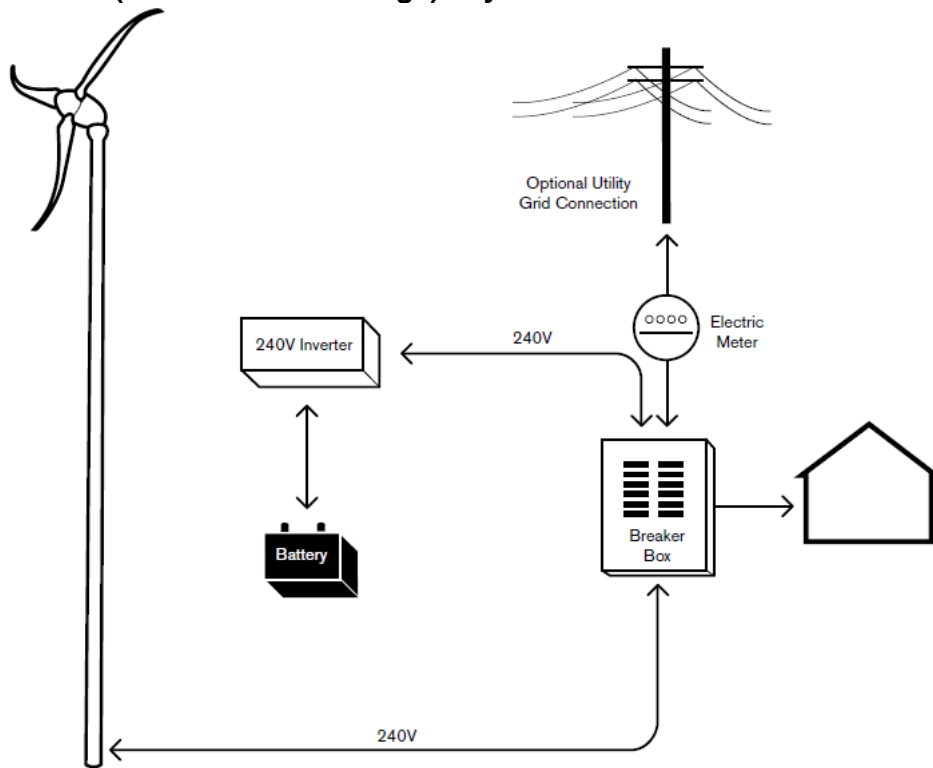

**Figure 2: Simplified depiction of Option A**

This configuration is a good choice for grid connected homes with a need for battery backup and 240 volts. The single 120/240 VAC inverter provides for a compact and neat installation.

**Option B 120/240 volt (US residential voltage) Skystream with two 120 VAC inverters**

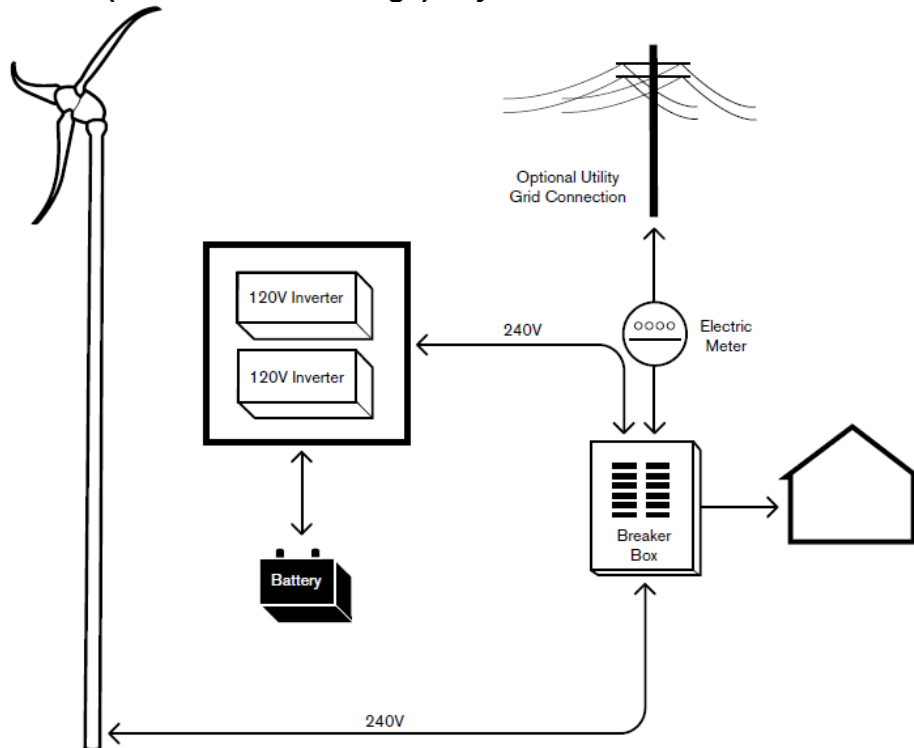

**Figure 3: Simplified depiction of Option B**

This configuration is a good choice for grid connected homes with a need for battery backup and 240 volts. The system requires two 120 VAC inverters wired in parallel. A detailed wiring schematics are contained in Appendix A, Figure 1.

**Option C 120/240 volt (US residential voltage) Skystream with 120 VAC inverter and transformer**

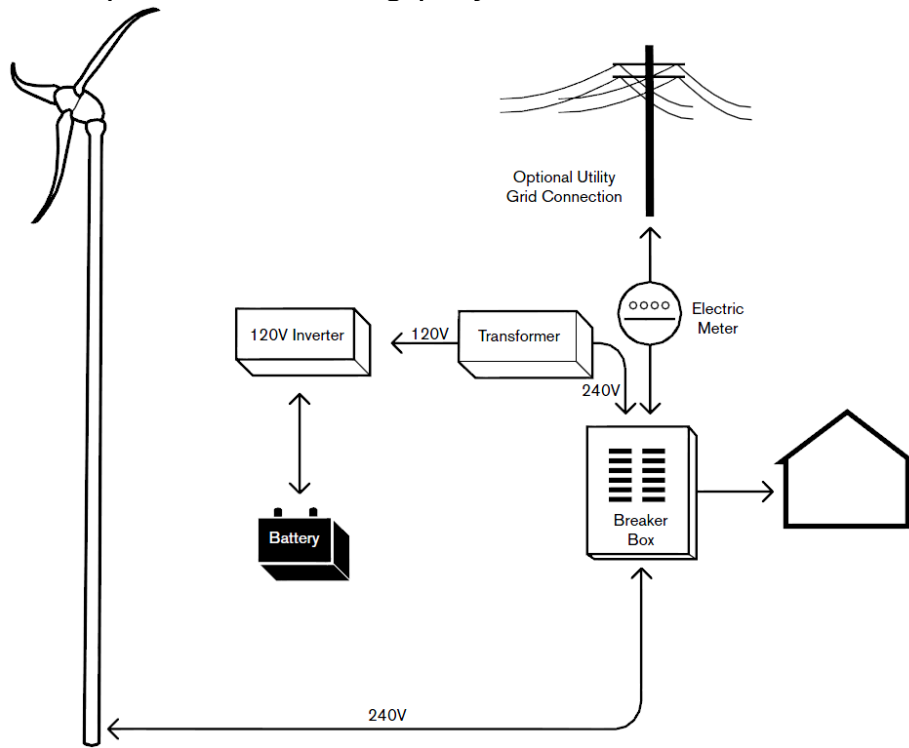

**Figure 4: Simplified depiction of Option C**

This configuration is a good choice for systems with an existing inverter. It supports 240 volt loads and utilizes a transformer to adapt the voltage between 240V and 120V. There is an inefficiency of approximately 20 watts associated with the transformer; however this inefficiency may be acceptable in high wind areas and based on the cost of the transformer compared to a second inverter. Detailed wiring schematics are contained in Appendix A, Figure 2.

**Option D 120 volt Skystream with a single 120 VAC inverter**

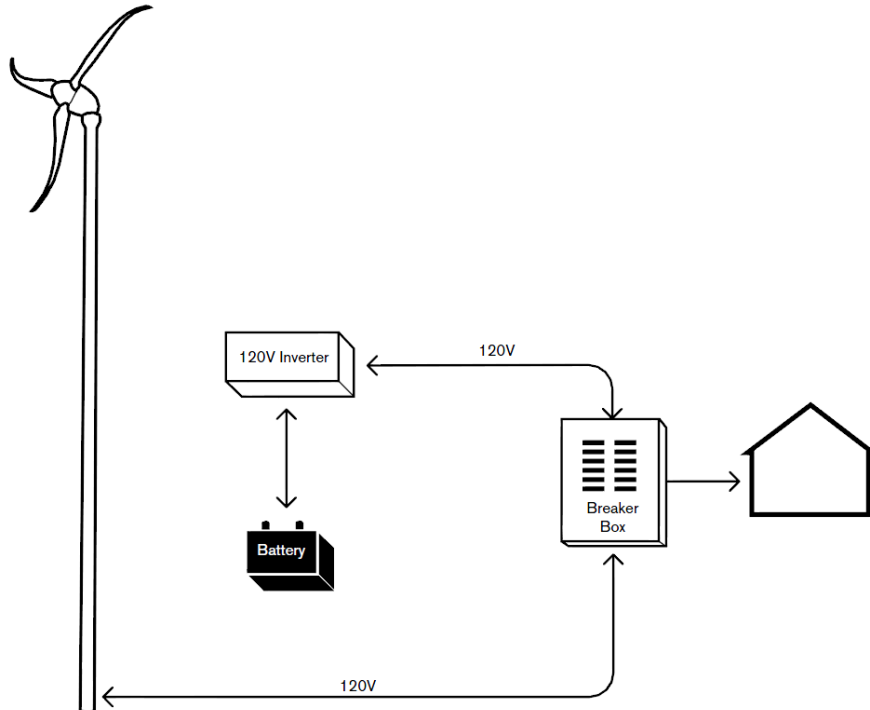

**Figure 5: Simplified depiction of Option D**

This option may be a good choice in applications that do not require 240 volt service. It is an economical system as only a single inverter is required.

However, because it is a 120 VAC system:

- The system may not be connected to the grid. 120 volt Skystream is not UL approved.
- The peak power available from the turbine is reduced which may make a 120/240 volt system a better choice in high wind areas.
- Wire is expensive if long wire runs are required – 120 volt systems require larger wire compared to 120/240 volt systems.
- In these scenarios a 120 volt system may not be the best choice.

Detailed wiring schematics are contained in Appendix A, Figure 3.

### **Battery Voltage Regulation and Diversion Loads**

In the event that the batteries become fully charged, it will be necessary to displace power that may otherwise overcharge and damage the batteries. In most cases, a grid-connected system can utilize the grid itself as an outlet for surplus energy (check with your local authorities for Net Metering requirements in your area).

Regardless, all battery charging systems must provide protective measures for circumstances of standalone operation (whether it is a stand-alone system or a grid connected system operating as a backup power supply).

In most cases, the host inverter will serve to protect the batteries from becoming overcharged if by no other means than that the host inverter will suspend operation with a high DC voltage disconnect function. Unfortunately, that will also interrupt power to both the loads and the Skystream (which will cause the Skystream to shut down). The SMA Sunny Island inverter is an exception as is any inverter that has load shedding capability. If the batteries reach full charge, the host inverter creates a phase shift which will cause the Skystream to shut down but continue to support high voltage loads.

It is preferable, however, to avoid shutting down the Skystream. Not only does it result in lower productivity, cyclical shut downs of the Skystream will increase the wear and tear on the turbine itself.

A common form of regulation that has been used throughout the history of small wind turbine battery charging systems is equally effective with the Skystream. A secondary diversion load and diversion load control on the DC bus can both allow the turbine to ride through the full charge condition, regardless of duration, and maintain availability. It also provides an outlet for useful energy that is otherwise lost if the turbine stops operating. The most common form of diversion load is a simple resistive heater for either air or water, and although a basic voltage-dependent switch can serve to “regulate” the flow of electricity to the battery, a pulse width modulating (PWM) style of switch is much more effective at maintaining battery state of charge and diverting only an amount of energy that would cause the batteries to exceed full charge voltage.

Special care should be given to the selection of diversion load and diversion load controller. The capacity of the load and controller must be matched to the maximum continuous output of the turbine and the resistance of the load must be appropriate for the operating voltage of the batteries.

PRESHENT Wind makes a suitably-sized load that is ordinarily used in conjunction with the Whisper 500 battery charging turbine. That and a high capacity diversion load controller such as a Morningstar TriStar60, a Xantrex C40 or C60 can complete the diversion control system. Various combinations of load and controllers can be combined in parallel depending on component capacity and operating voltage to achieve the net diversion capacity required, but for simplicity a single PWM controller and load is desirable.



## Wire Sizing

These wire sizing directions are for SINGLE Skysteam turbine installations which are home-run to a main service panel. DO NOT attempt to use these wire sizing instructions for a Skysteam connected to a sub-panel or for multiple Skystreams together.

Note that the largest wire size that may be connected to the Skystream yaw terminals is #8 AWG (6 mm<sup>2</sup>). For installations requiring a larger wire size (because of distance), PRESHENT Wind recommends using a disconnect switch box installed between the tower and utility panel to transition to a larger wire size.

To determine the appropriate wire size, measure the total distance from the turbine to the electrical utility panel, including the tower height, and refer to the tables below.

Table 2 includes maximum wire length information for wire sizes #8 AWG (10 mm<sup>2</sup>) and smaller without transitioning to a larger wire size. Select the appropriate wire size based on the total wire length and Skystream voltage configuration (240 VAC, split phase or 120 VAC, 1 phase).

**Table 2**

Wire Size	120/240 VAC, Split Phase	120 VAC, 1 Phase
4 AWG (25 mm <sup>2</sup> )	See Table 2	See Table 3
6 AWG (16 mm <sup>2</sup> )	See Table 2	See Table 3
8 AWG (10 mm <sup>2</sup> )	303 ft (92 m)	245 ft (75 m)
10 AWG (6 mm <sup>2</sup> )	190 ft (58 m)	155 ft (47 m)
12 AWG (4 mm <sup>2</sup> )	120 ft (37 m)	95 ft (29 m)
14 AWG (2.5 mm <sup>2</sup> )	75 ft (23 m)	60 ft (18 m)

Use copper conductors only - Minimum wire temperature rating is 75° C (167° F). Distance and wire size for 120/240 VAC, split phase systems based on 2400 watt power production and 2% (L-L) line loss. Distance and wire size for 120 VAC systems based on 1500 watt power production and 4% (L-L) line loss.

**Table 3**

System Voltage	Maximum Wire Length	# 8 AWG	# 6 AWG	# 4 AWG
120/240 VAC, Split Phase	650 ft (198 m)	75 ft (22.9 m)	-----	575 ft (175 m)
120/240 VAC, Split Phase	435 ft (133 m)	75 ft (22.9 m)	360 ft (110 m)	-----
120 VAC, 1 Phase	600 ft (180 m)	75 ft (22.9 m)	-----	525 ft (160 m)
120 VAC, 1 Phase	405 ft (123 m)	75 ft (22.9 m)	330 ft (100 m)	-----



**Warning:** For your safety, make sure power is turned off before working on any and all electrical connections.

If the required wire length is greater than can be accomplished with #8 AWG (10 mm<sup>2</sup>) wire, refer to Table 3. This table includes wire size information for installations requiring a transition to a wire size larger than #8 AWG.

Table 3 provides for a 75 ft (23 m) length of # 8 AWG (10 mm<sup>2</sup>) wire to be run from the Skystream yaw to a disconnect switch box and a length of #4 or # 6 AWG (25 or 16 mm<sup>2</sup>) wire to be run from the disconnect switch box to the utility panel. Select the appropriate wire size combination based on the wire run length and Skystream voltage configuration.

**Note:** If needed, the 75 ft (23 m) length of #8 AWG (10 mm<sup>2</sup>) wire may be shortened and the larger gauge wire lengthened a corresponding amount. However, DO NOT lengthen the #8 AWG (10 mm<sup>2</sup>) wire and lengthen the larger gauge wire.

**Skystream 3.7**  
**APPENDIX A: ELECTRICAL DIAGRAMS**

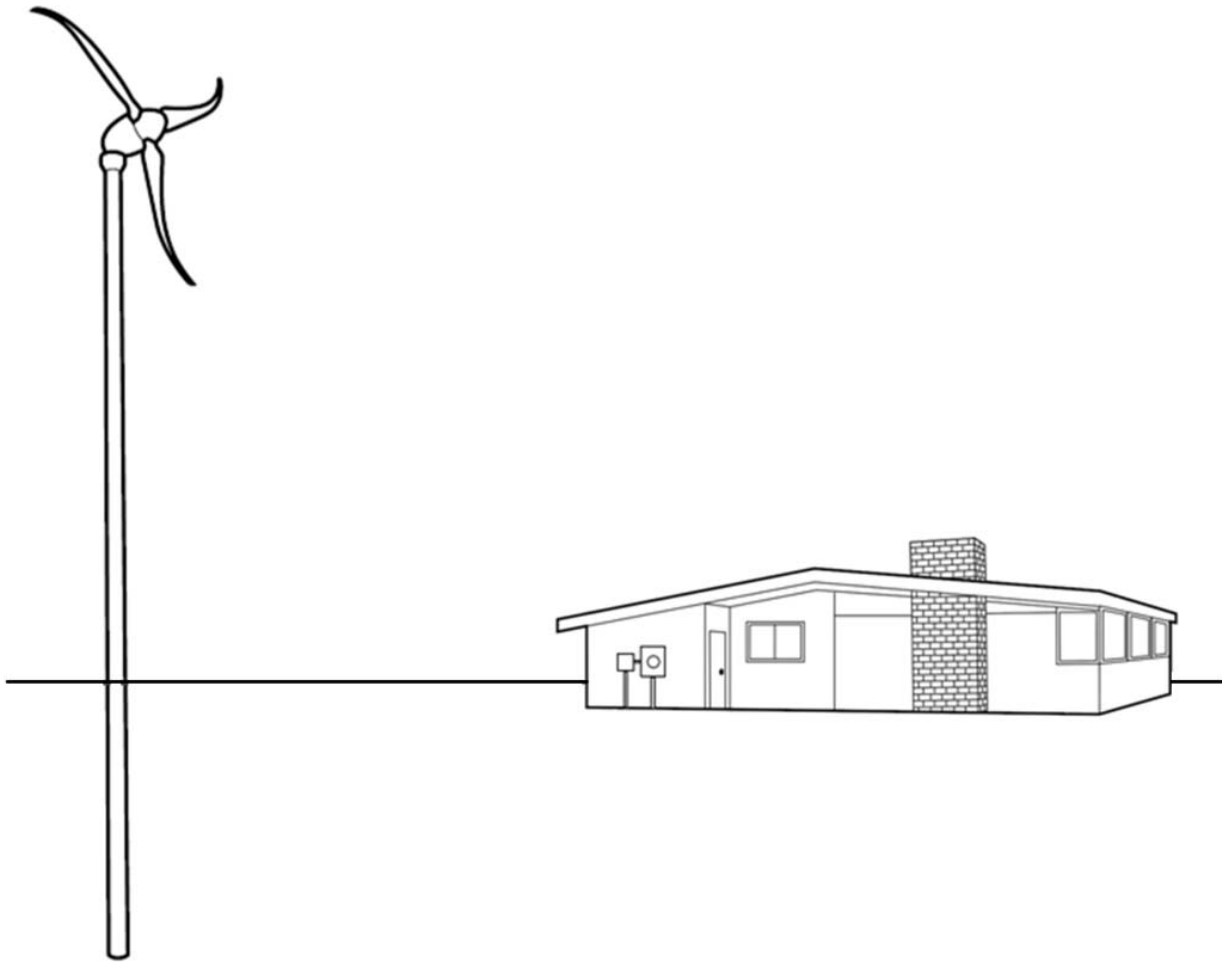

**Figure 1 Option B**  
120/240 volt (US residential voltage) Skystream with two 120 VAC inverters ..... 11

**Figure 2 Option C**  
120/240 volt (US residential voltage) Skystream with 120 VAC inverter and transformer ..... 12

**Figure 3 Option D**  
120 volt Skystream with single 120 VAC inverter ..... 13

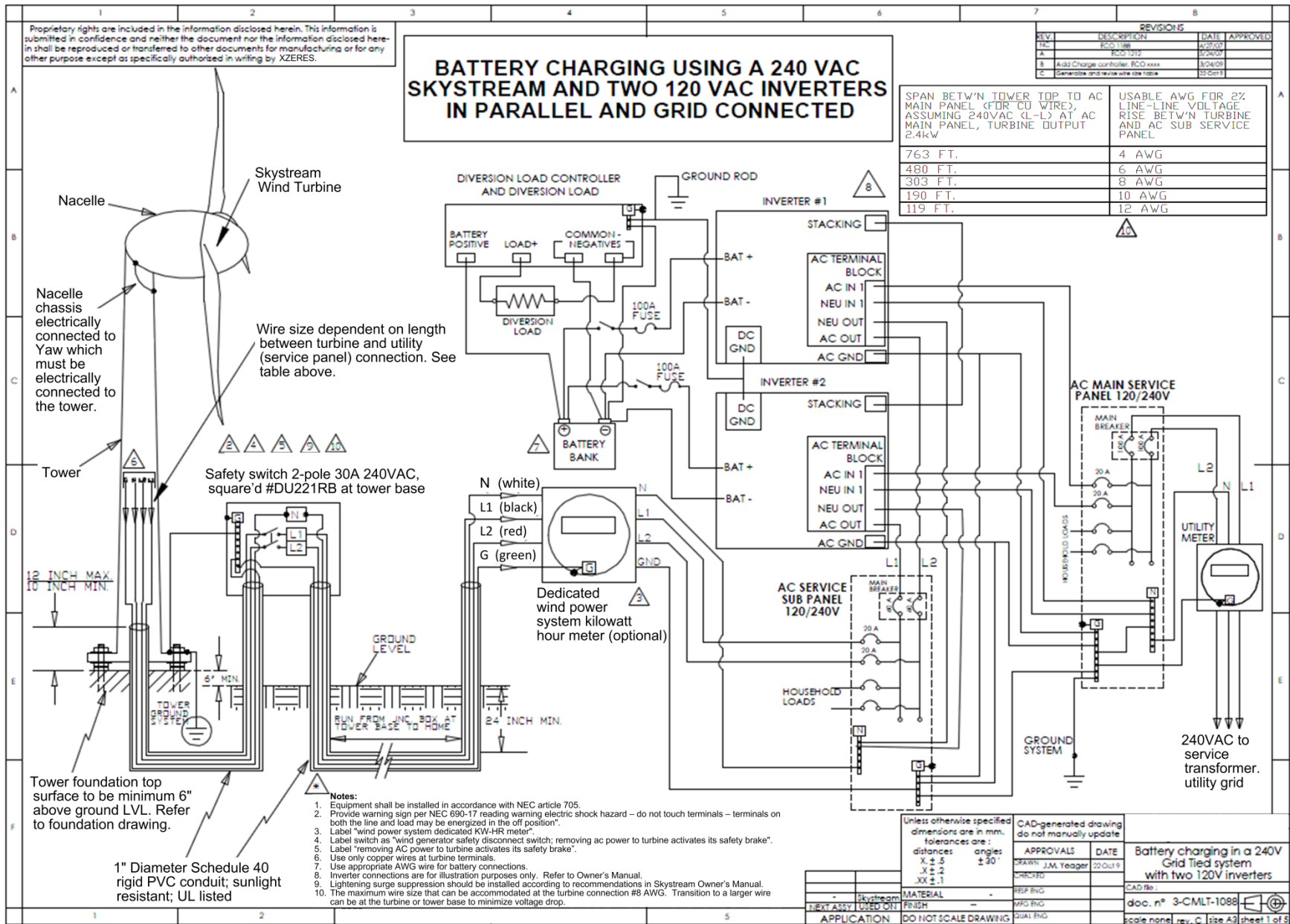

**Figure 1: Option B - 120/240 volt (US residential voltage) Skystream with two 120 VAC inverters**

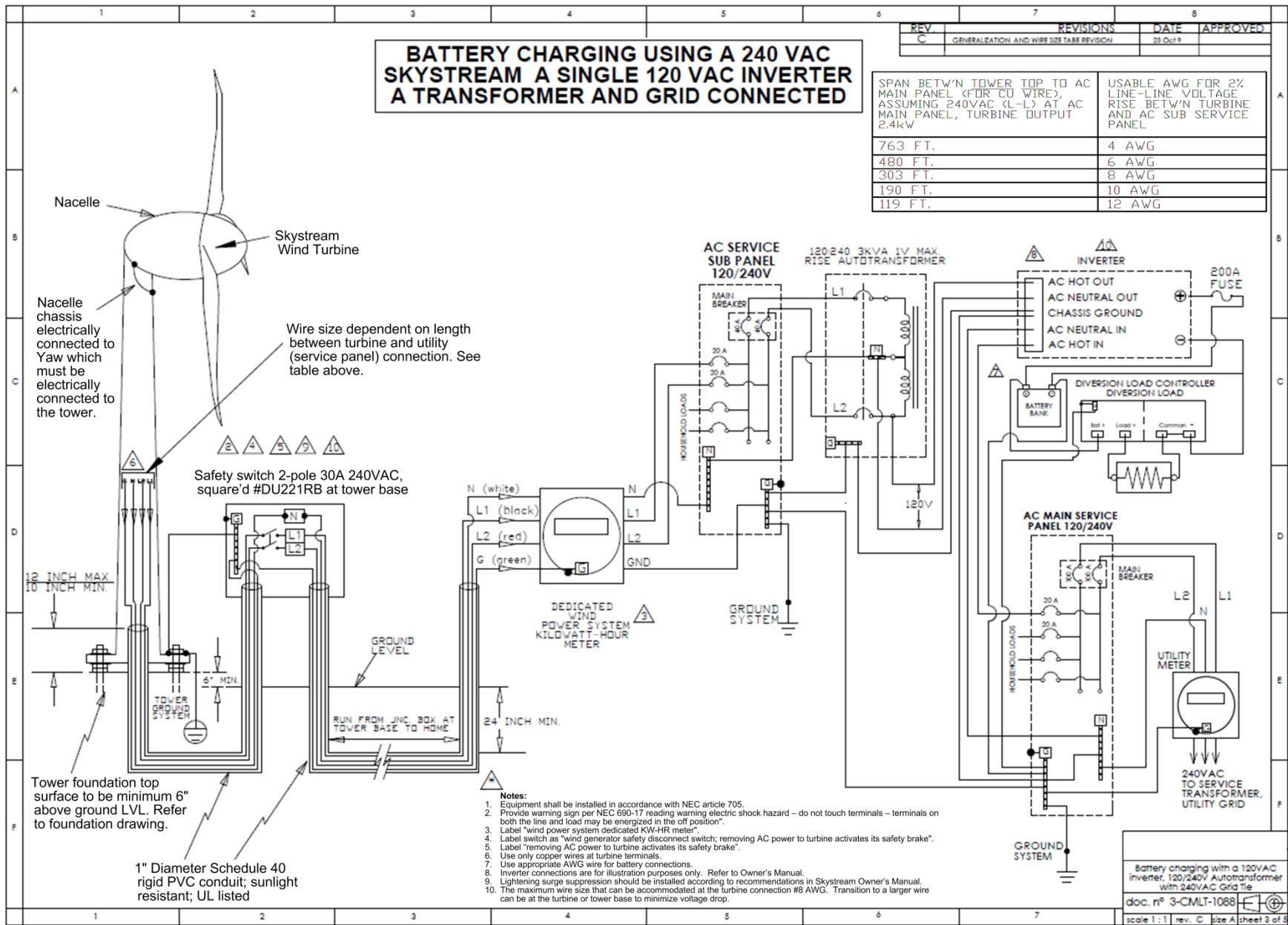

**Figure 2: Option C - 120/240 volt (US residential voltage) Skystream with 120 VAC inverter and transformer**

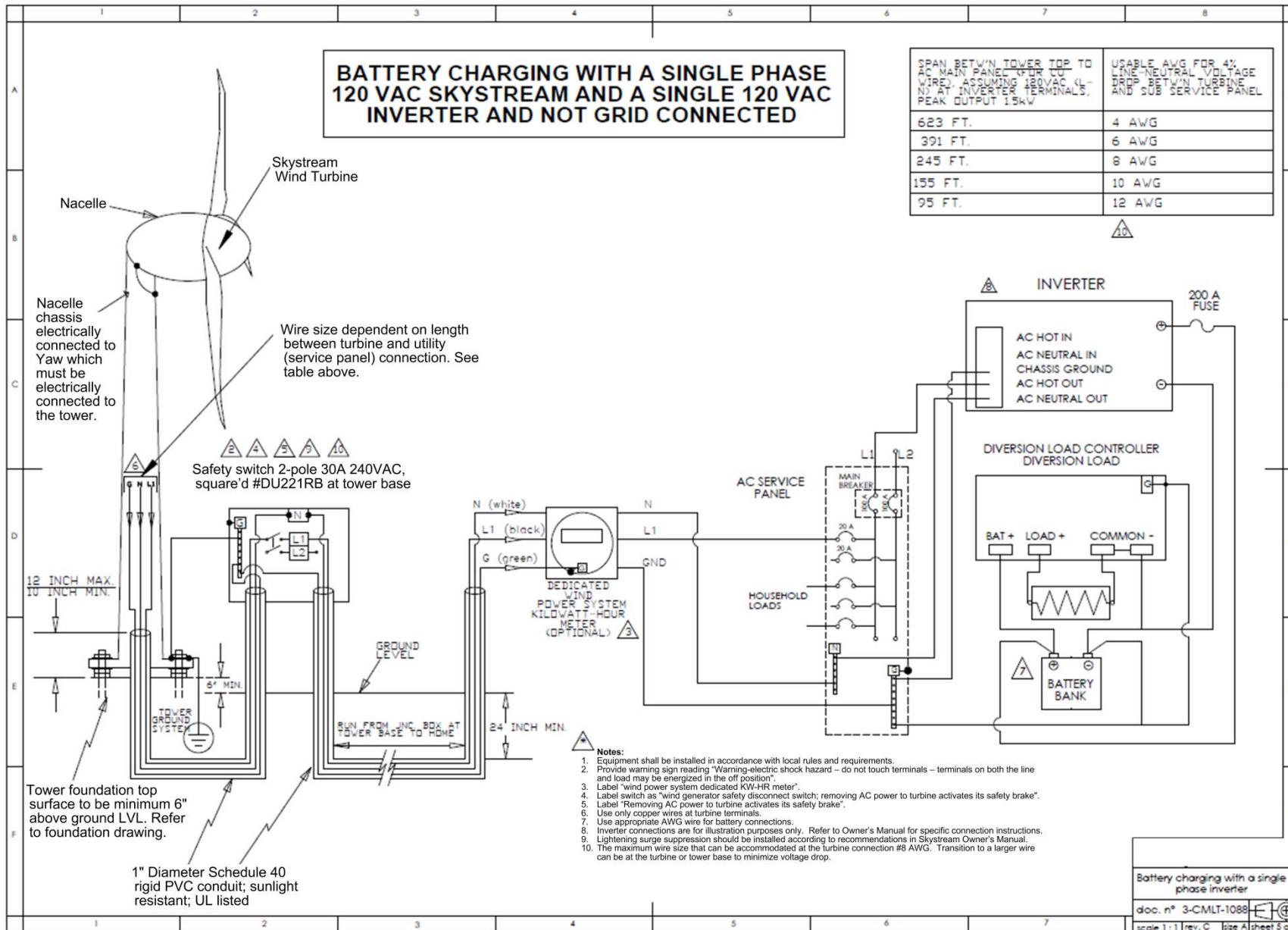

**Figure 3: Option D - 120 volt Skystream with single 120 VAC inverter**

# PRESHENT

Toll Free:1-888-575-4880  
[www.preshent.com](http://www.preshent.com)