

Cameron

Micro Drill Presses

a division of Treat Enterprises, Inc.

19401 Rawhide Road • Sonora, CA 95370 • Phone: 209-532-7201 • Fax: 209-532-1211

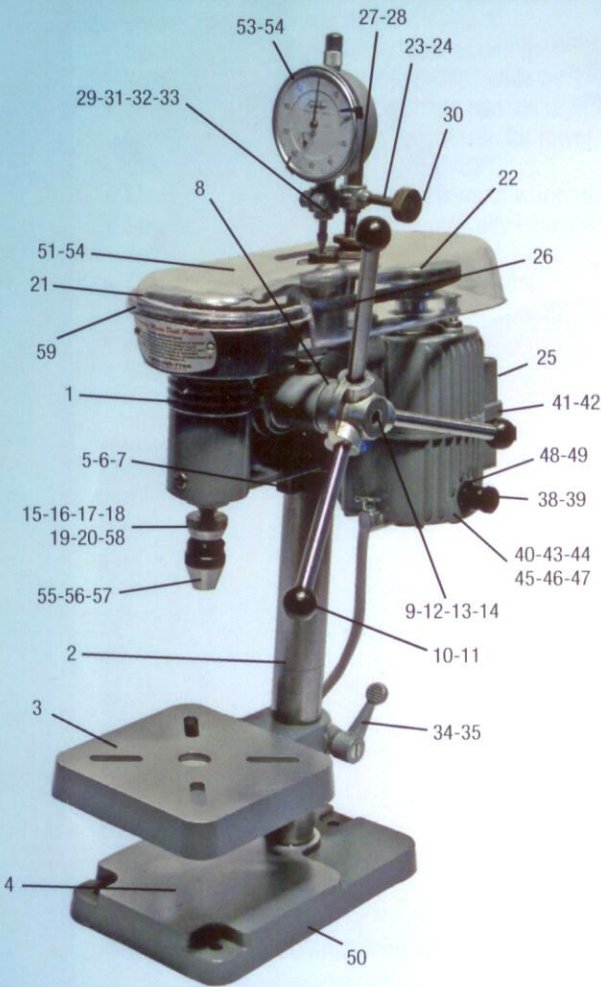

**Cameron Series 164
Micro Drill Press**

**Cameron
MD-90 Micro
Max with
Precision
Ground Base**

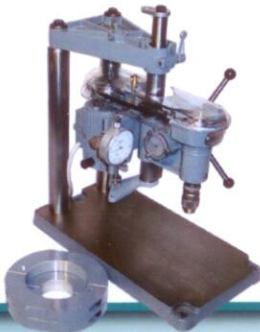

Micro Drill Press Parts List

- | | | | |
|--------------|---|---------------|--|
| 1. MD-101-7 | Head (complete with bearings) | 33. MD-133-7 | Column Lock Screw Lever |
| 2. MD-102-7 | Column | 34. MD-134-7 | Table Lock Screw |
| 3. MD-103-7 | Table | 35. MD-135-7 | Table Lock Screw Thumb Lever |
| 4. MD-104-7 | Base | 36. MD-136-7 | Motor Mount |
| 5. MD-105-7 | Rack | 37. MD-137-7 | Knurled Lock Screw |
| 6. MD-106-7 | Pinion | 38. MD-138-7 | Motor Brushes with springs (set of 2) |
| 7. MD-107-7 | Pinion Shaft | 39. MD-139-7 | Brush Holders with caps and connectors (set of 2) |
| 8. MD-108-7 | Oil Hole Fitting (Pinion Shaft) | 40. MD-140-7 | Motor Bearings with retainers and oil felts |
| 9. MD-109-7 | Spoked Feed Wheel Hub | 41. MD-141-7 | Motor Case Section (pulley end) |
| 10. MD-110-7 | Feed Wheel Lever (threaded) | 42. MD-142-7 | Motor Case Section (brush holder end) |
| 11. MD-111-7 | Feed Wheel Lever (grooved) | 43. MD-143-7 | Armature |
| 12. MD-112-7 | Return Spring | 44. MD-144-7 | Field Assembly |
| 13. MD-113-7 | Return Spring Clamp Ring | 45. MD-145-1 | Switch for single speed motor |
| 14. MD-114-7 | Slotted Spring Tension Adjuster | 46. MD-145-2 | Switch for two speed motor |
| 15. MD-115-7 | Spindle | 47. MD-146-7 | Electric Cord |
| 16. MD-116-7 | Set of Spindle Bearings factory installed (send drill press head only to factory where new spindle bearings will be installed and head returned promptly to sender) | 48. MD-147-1 | Motor (single speed with switch and cord) |
| 17. MD-117-7 | Half Rings for Spindle (set of 2) | 49. MD-147-2 | Motor (two speed with switch and cord) |
| 18. MD-118-7 | Half Ring Retainer for above Hal Rings | 50. MD-148-7 | Screws (complete set for drill press and motor) |
| 19. MD-119-7 | Thrust Bearing Assembly (spindle upper) | 51. MD-149-7 | Oil hole plugs for drill press Head (set) |
| 20. MD-120-7 | Thrust Bearing Assembly (spindle lower) | 52. MD-150-7 | V-Belt |
| 21. MD-121-7 | Pulley (spindle) | 53. MD-151-7 | Dial Indicator |
| 22. MD-122-7 | Pulley (motor) | 54. MD-152-7 | Attachments for Mounting Dial Indicator on Drill Press |
| 23. MD-123-7 | Knurled Depth Stop Nuts (set of 2) | 55. MD-153-7 | Jacobs Geared Chuck with Key (5/32" capacity) |
| 24. MD-124-7 | Depth Stop (column end nut abutment casting) | 56. MD-154-7 | Albrecht Keyless Chuck (0 to 1/16" capacity) |
| 25. MD-125-7 | Motor resistor for low speed switch position of two speed motor | 57. MD-155-7 | Albrecht Keyless Chuck (0 to 1/8" capacity) |
| 26. MD-126-7 | Head Raising Stop Bumper (resilient plastic) | 58. MD-156-7 | Spindle with Spindle Pulley as a Matched and Balanced Assembly |
| 27. MD-127-7 | Depth Stop Stem (for machine without indicator) | 59. MD-157-7 | Guard |
| 28. MD-128-7 | Depth Stop Stem and Indicator Post | 60. MD-158-7 | Chuck Wedges |
| 29. MD-129-7 | Indicator Adjustment Bracket | 61. MD-159-2A | Cameron International VSC 240/120 V.AC |
| 30. MD-130-7 | Knurled Clamp Screw for Indicator Adjustment Bracket | 62. MD-159-FS | Foot Switch (international) for Cameron VSC Unit |
| 31. MD-131-7 | Column Lock Screw | 63. MD-160-7 | Jacobs 1/4" Keytype Chuck |
| 32. MD-132-7 | Column Lock Screw Pad | 64. MD-161-7 | Precision Table Column Stop |
| | | 65. MD-162-7 | Reservoir Base for Series 164 |
| | | 66. MD-163-7 | ChuckGuard |