

U-TUBE BUNDLE (in tank/service)

BAFFLE CUT ORIENTATION

(circle one)



Horizontal Vertical Full

NUMBER OF BAFFLES:

NUMBER OF PASSES

(circle one)



2-Pass 4-Pass 8-Pass

BOLTING INFORMATION:

(circle one)

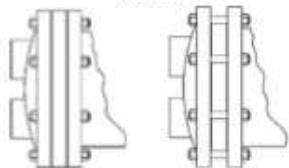

Full Face Boltless Tube Sheet

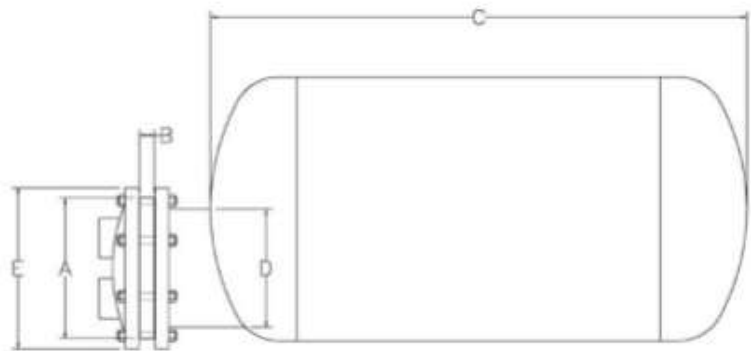

DIMENSIONAL INFORMATION:				
A:	B:	C:	D:	E:

MATERIALS OF CONSTRUCTION:			
TUBE SHEET:	U-TUBES (MATERIAL):	TUBE OD & THICKNESS:	BAFFLES:

BOLTING INFORMATION: (if applicable)	
NUMBER OF BOLTS:	
BOLT HOLE DIAMETER:	
BOLTING MATERIAL:	
BOLT CIRCLE DIAMETER:	

ADDITIONAL NOTES:

(Check Appropriate Boxes)	<u>Tubeside</u>	<u>Shellside</u>	CURRENT UNIT:	Contact Information:	
				Company:	
Water			Manufacturer:	Name:	
Domestic Water				Phone:	
High-Temp. Water			Model Number:	Email:	
Low-Pressure Steam				Date:	
High-Pressure Steam					

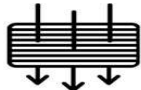

HICO
COILS, LLC

www.hico-coils.com
918-530-9353
elh@hico-coils.com