



Impressive Block™ User Instruction Manual

Contents

Components of the Impressive Block™ System.....	1
Materials of Construction	3
Allowable Conditions	4
Running the Impressive Block™ System	4
Assembly of the Coil Tubing Impressive Block™ System.....	5
Disassembly of the Coil Tubing Impressive Block™ System	6
Assembly of the Slickline Impressive Block™ System	7
Disassembly of Slickline Impressive Block™ System	10
Field Customization of Slickline Adapters	13
Maximum Allowable Tension for Slickline Adapters	15
Ordering Standard Sizes, Part Numbers and Accessories.....	16
Slickline Only – Parts Selection for Custom Sizes	17
Warranty:.....	25

Components of the Impressive Block™ System

**All dimensions shown in this manual are in inches unless called out otherwise.*

Slickline Cup (also called a carrier - reusable indefinitely):

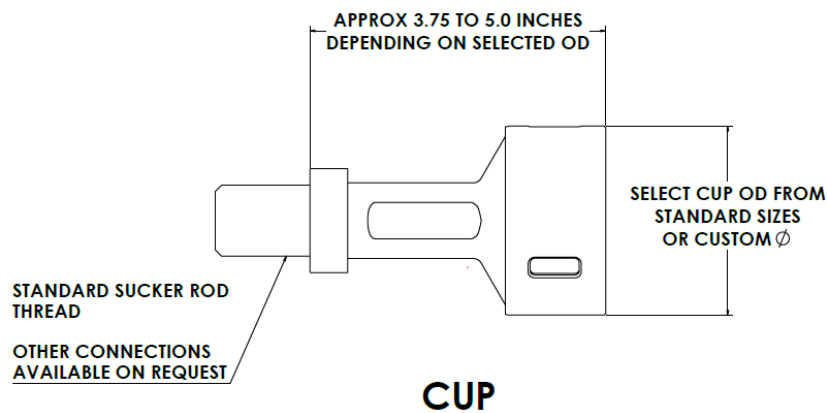

Puck adapters, for Slickline version only (single use retention ring not shown – adapters reusable indefinitely):

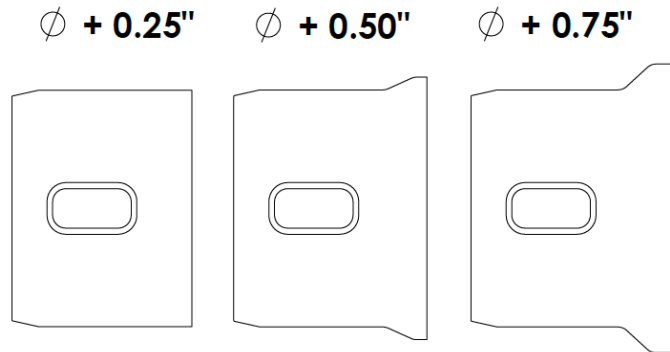

Coil Tubing cup (also called a carrier - reusable indefinitely)

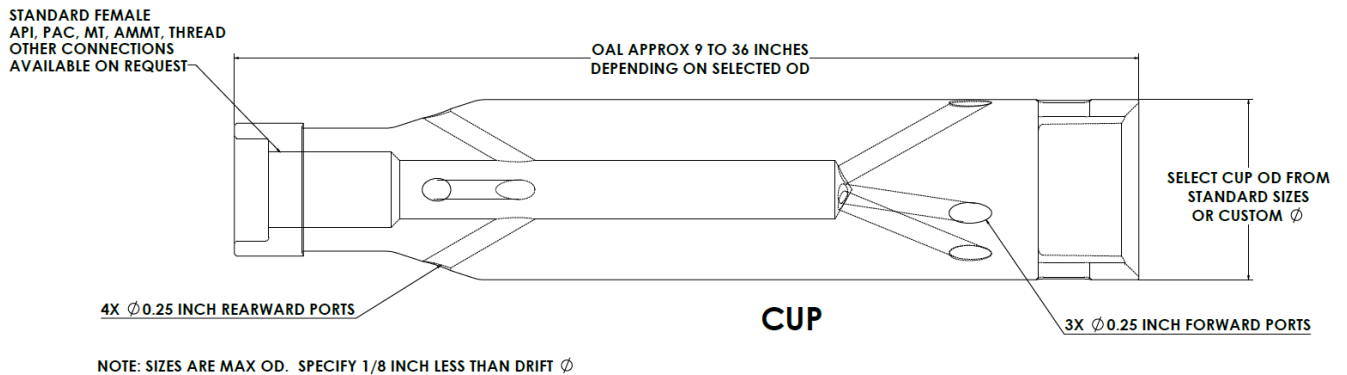

Puck (single use only):

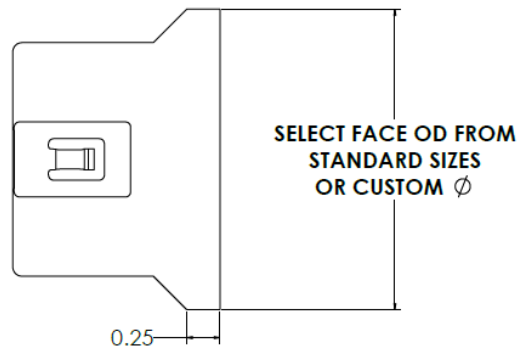

Puck Removal Tool – aka “Pick Tool” (reusable indefinitely):

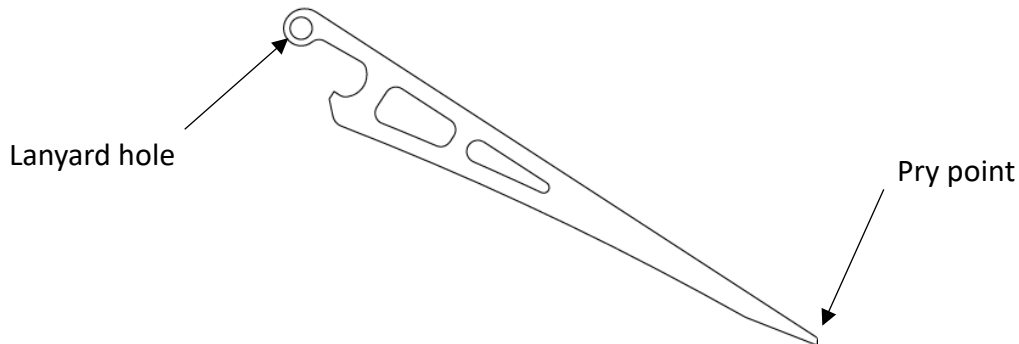

Materials of Construction

The Slickline and Tubing Conveyed cups, and their adapters, are all made from 4140 steel. The pick tool is made from 1018 steel. The Slickline adapter retaining rings are made from 302 stainless steel.

The Impressive Block™ puck is made of aluminum and a fully cured polymer resin to form a composite. Neither of these materials present any chemical hazards to the user or environment, thus no Safety Data Sheet is required. However, after the puck has been run in a well it may contain residue of wellbore fluids and the user should determine handling procedures after a run based on conditions.

A used puck may be gently washed with a water-based degreasing agent followed by soapy water to remove wellbore residue, as necessary, without damage. Direct application of strong solvents, such as acetone, on the puck is not recommended.

If the used puck is to be provided to another party for analysis, enclose the puck appropriately, such as in a zipper sealed plastic bag (solvent resistant is necessary), to prevent any wellbore fluids absorbed by the puck from effecting packaging. Also provide adequate packing material and impact protection, such as a cardboard box, to preserve the impression details.

The cups, retention rings, adapters and pick tool are all of steel construction of alloys chosen to meet cost and performance requirements.



Allowable Conditions

Storage conditions – The puck should be stored in its original packaging, protected from rough handling, out of sunlight and rain, and at temperatures not exceeding 165 F (74 C) for full storage life.

Assembly conditions – The cup, adapter and puck system should be assembled under good lighting conditions to verify that the retention ring (*if required*) and puck retention snaps are fully seated and engaged before use. The integrity of the retention snaps is particularly important to verify when assembling the puck in extremely cold conditions. Snap flexibility has been tested down to -10 F (-23 C).

Wellbore operating conditions – The puck is rated for use at temperatures up to +450 F (232 C). Higher temperatures are available by special order only – contact manufacturer. The puck and cup assembly may be used at any wellbore pressure.

Wellbore fluid conditions – The puck is rated for use in H₂S, gas and oil fluids, brines, as well as aqueous solutions between 4-10 pH. Pucks for use in highly reactive fluids, or pH conditions lower than 4 or higher than 10, are available by special order only – contact manufacturer. The cup assembly itself is rated for use in all conditions.

Running the Impressive Block™ System

The Impressive Block™ tool is run using the same toolstring configuration and procedures as a standard Lead impression block (LIB).

- ! Inspect the Impressive Block™ tool before use for damage to threads, the cup and adapter rim, as well as corrosion at the joint between the adapter and the retaining ring (Slickline only). Replace damaged or corroded components to prevent failures.

The Impressive Block™ is more sensitive to the impact of a single jar-down than an LIB, and will provide deeper indentations for easier fish identification. This will be especially helpful in getting good results in highly deviated wells when using Slickline conveyance. Do NOT use multiple jar-down impacts to make an impression.

The impressions in the puck are permanent; therefore, the puck cannot be re-dressed. After an impression has been made on a puck, a new puck must then be used for the next run.



Assembly of the Coil Tubing Impressive Block™ System

- ! Ensure the correct size is chosen for the cup and puck for the fishing run. Each puck size will only fit in its intended cup size. Modifying a tubing conveyed puck or cup to attempt to use differently invalidates the warranty and is likely to create a failure.

Inspect the puck to ensure it is intact and undamaged. If the puck is damaged but has not been run in a well, it may be recycled with aluminum waste or disposed of in a common trash can.

Ensure the inside of the cup is free of debris. To prevent inadvertent indents or marks on the puck, it may be best to wait until the toolstring is fully assembled before installing the puck.

See assembly instruction illustrations below.

1. Remove puck from its protective packaging.
2. Align puck snaps with cup grooves.
3. Push puck straight in until the puck bottoms out in the cup.
4. Visually verify retention snaps are fully seated in slots.

There are at least two robust snaps that hold the puck in the cup, depending on cup size. Even if one snap were damaged during fish impact the remaining snap(s) will be sufficient to retain the puck. After impact with a fish downhole, the puck expands into the cup and will require the pick tool to remove. These redundant design features assure the puck stays in the cup when returning to the surface.

ASSEMBLY STEPS

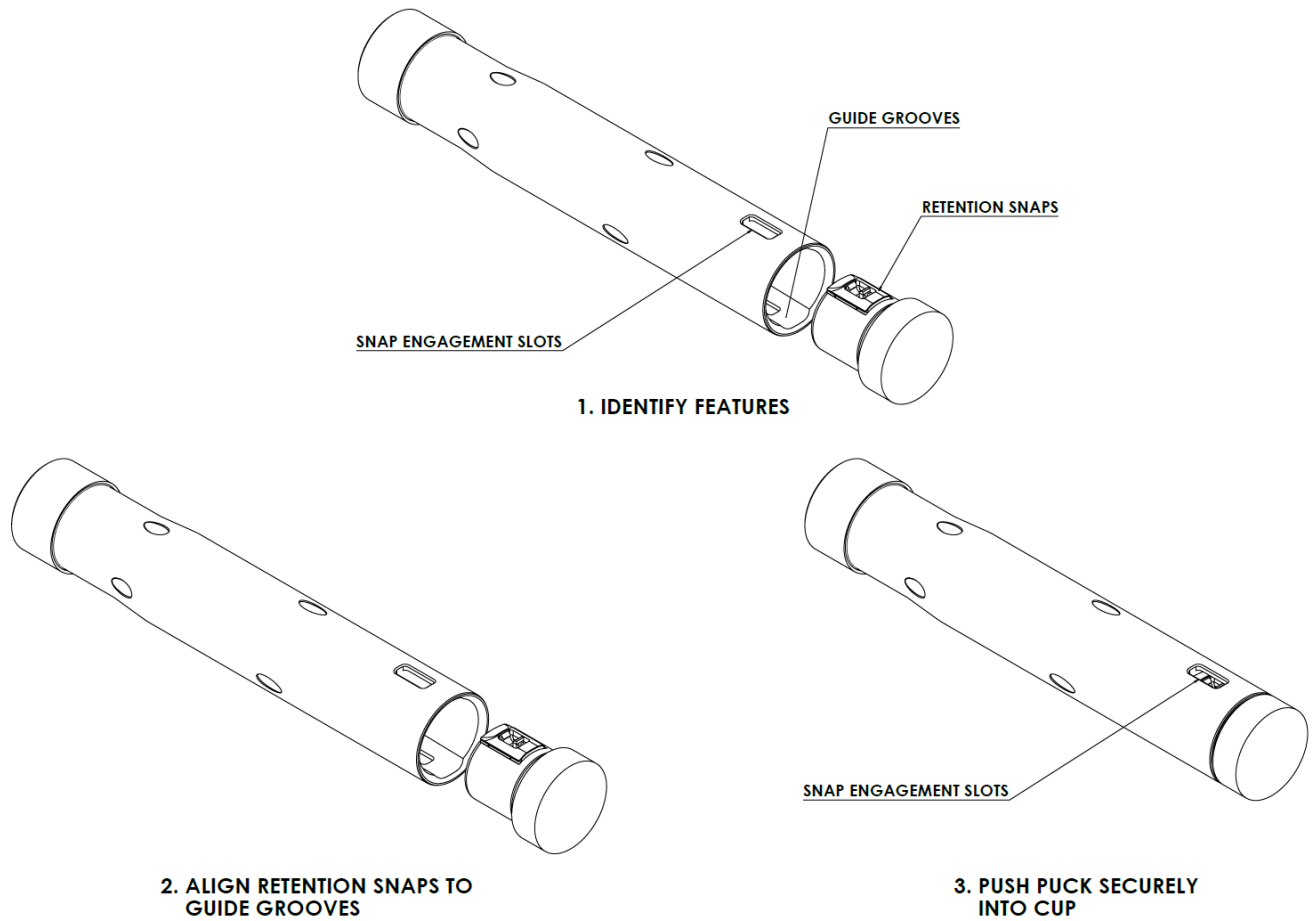

Disassembly of the Coil Tubing Impressive Block™ System

WARNING: It is recommended practice to wear puncture resistant gloves during this procedure.

See the disassembly instruction illustrations shown below.

1. Remove the cup assembly from over the wellbore opening.
2. Use the Pick Tool to break off snaps by prying.
3. Then insert the Pick Tool between the cup and puck, and pry up to release it as necessary.

A small, flat-bladed screw driver may also be used as an alternate puck removal tool.



BREAK RETENTION SNAPS

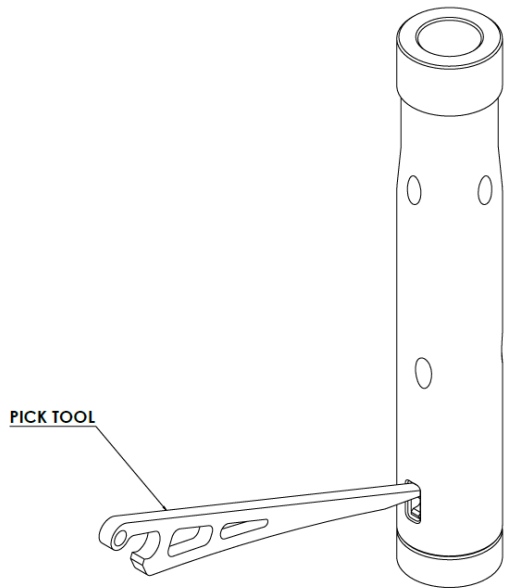

TIP: BREAK SNAP AT TOP OF RETENTION CLIPS

PRY PUCK FROM CUP

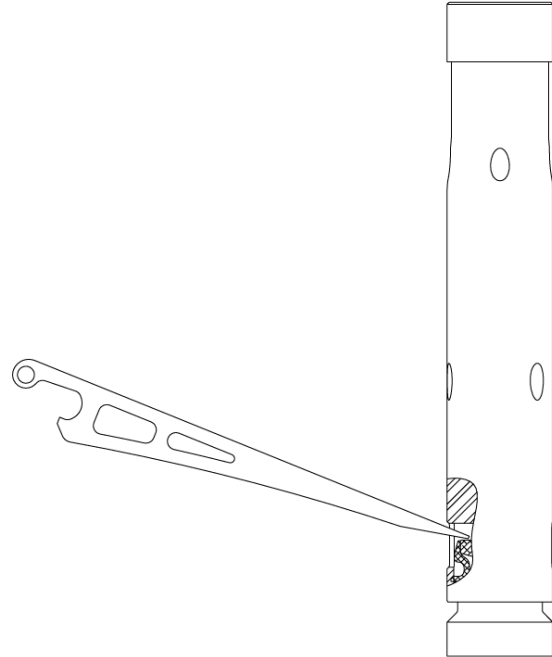

Assembly of the Slickline Impressive Block™ System

The SL version is designed such that each cup has a core size that can accommodate four sizes of pucks for increased flexibility and reduced system cost.

To assemble the Slickline system, first identify the size of impact face you need, consult the parts chart (Table 3 of this manual) to identify the cup you need to use along with its core size, and the appropriate adaptor, if required.

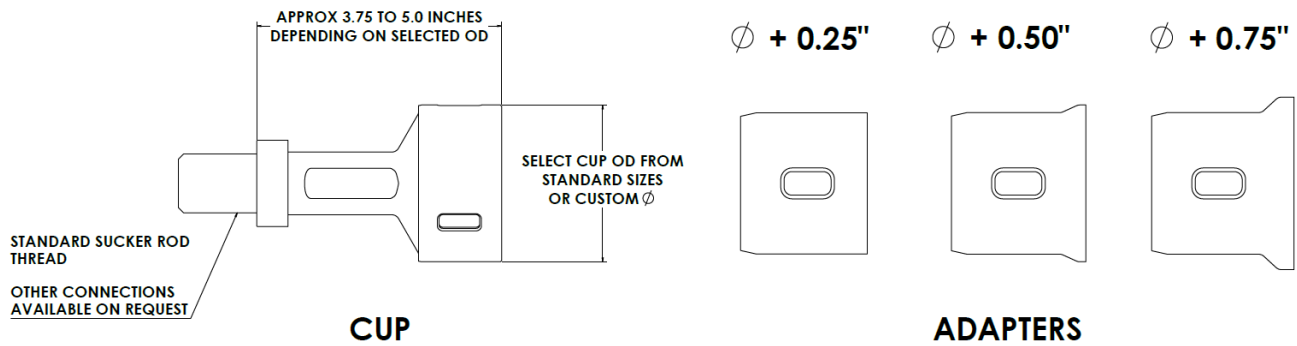

NOTE: ADAPTORS ARE FOR SELECTED CUP OD + ADAPTOR SIZE
 SOME CUP AND PUCK SIZE COMBINATIONS DO NOT
 REQUIRE AN ADAPTOR



- ! Inspect the Impressive Block™ tool before use for damage to threads, the cup and adapter rim, as well as corrosion at the joint between the adapter and the retaining ring. Replace damaged or corroded components to prevent failures.

Inspect the puck to ensure it is intact and undamaged. If the puck is damaged and has not been run in a well, it may be recycled with aluminum waste or disposed of in common trash.

Ensure the inside of the cup is free of debris. To prevent inadvertent indents or marks on the puck, it may be best to wait until the toolstring is fully assembled before installing the puck into the cup.

See assembly instructions and illustrations below.

1. Install the adapter, if required. Secure it by fully installing the provided retention ring.
 - a. *Note: A new retention ring is provided with every box of pucks. When opening a new box, ensure that the old ring is discarded and replaced with the new ring. Additional retention rings may be purchased separately, if desired.*
2. Remove puck from its protective packaging.
3. Align puck snaps with cup grooves.
4. Push puck straight in until the puck bottoms out in the cup. Pucks are designed to fit tightly. If the puck does not go in easily, first verify that you have the right sized puck. Then place the face of the puck against the smooth, flat surface of a sturdy work table and push down with the cup in your hand to insert the puck until it clicks into place.
5. Visually verify retention snaps are fully seated in slots.
6. Rotate adapter, if required, so that snap slots are no longer visible.

There are at least two robust snaps that hold the puck in the cup. Larger pucks have more snaps. Rotating the adapter provides an additional mechanism of puck retention. Even if a snap were damaged during fish impact the remaining snap(s) would be sufficient to retain the puck. During impact with the fish the puck expands inside the cup, further locking it into the cup. These redundant design features assure the puck stays in the cup when returning to the surface.

ASSEMBLY STEPS

NOTE: SKIP STEPS 2, 3, AND 6 IF ADAPTER IS NOT REQUIRED

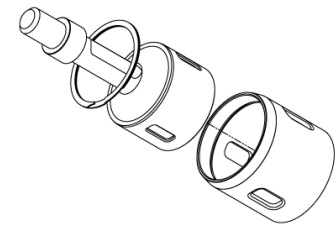
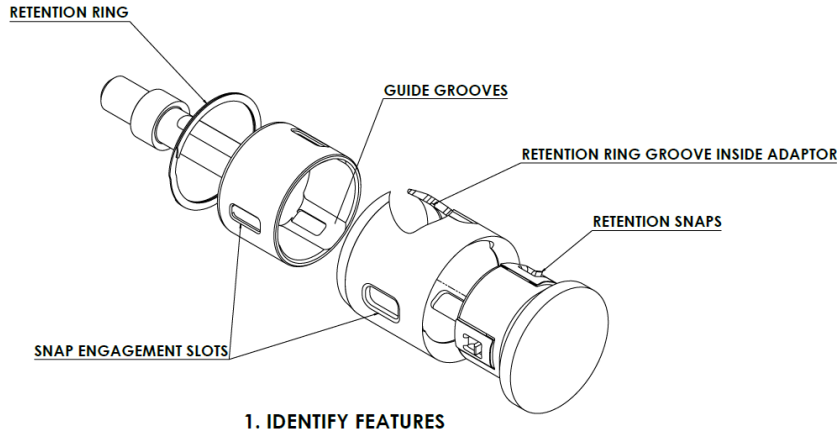

2. PUSH ADAPTER OVER CUP AND
INSTALL RETENTION RING INTO
RETENTION RING GROOVE INSIDE
ADAPTER

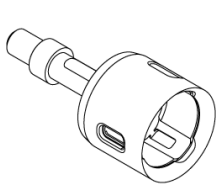

3. ALIGN ADAPTER SLOTS
WITH CUP SLOTS

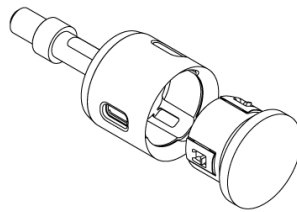

4. ALIGN RETENTION SNAPS TO
GUIDE GROOVES

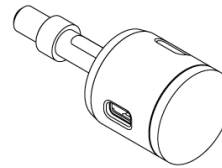

5. PUSH PUCK SECURELY
INTO CUP

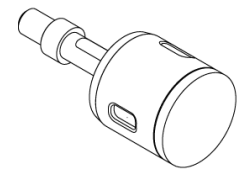

6. ROTATE ADAPTER UNTIL
GUIDE GROOVES NOT
VISIBLE

This is what the fully assembled system should look like:

2.00" CUP WITH 2.00" PUCK

2.00" CUP WITH 2.25" PUCK

2.00" CUP WITH 2.50" PUCK

2.00" CUP WITH 2.75" PUCK

NOTE: THERE ARE MULTIPLE CUP SIZES. PLEASE SEE INSTRUCTION OVERVIEW FOR CUP, ADAPTOR, AND PUCK SELECTION

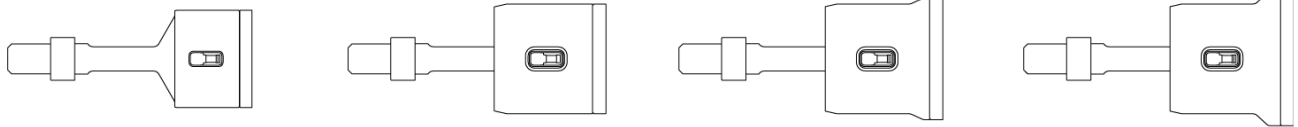

NOTE: THE COMBINATION OF 2.00" CUP AND 2.00" PUCK DOES NOT REQUIRE AN ADAPTOR

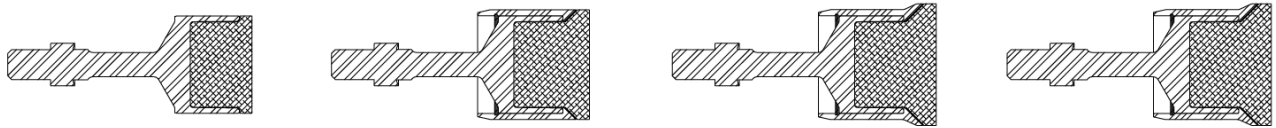

Disassembly of Slickline Impressive Block™ System

WARNING: It is recommended practice to wear puncture resistant gloves during this procedure.

See the disassembly instructions and illustrations shown below.

1. Remove the cup assembly away from the wellbore opening.
2. Use supplied pick tool to break off snaps by gently prying under them.
3. Then insert the pick tool between the cup and puck and pry up to release the puck as necessary.
4. Remove and discard retention ring after each run.

When necessary, a small, flat-bladed screw driver may also be used as an alternate for the pick tool.

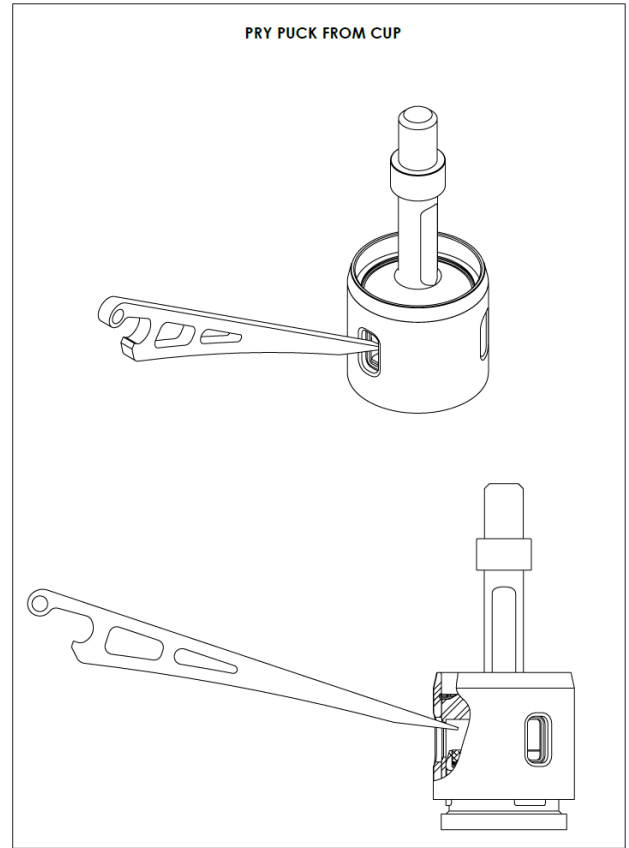
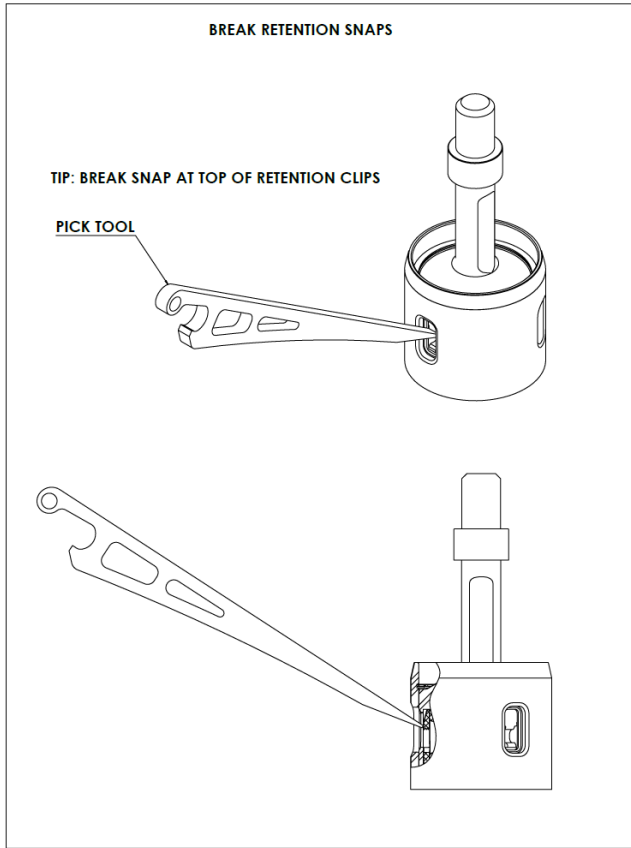

NOTE: SKIP THESE STEPS IF ADAPTOR IS NOT REQUIRED

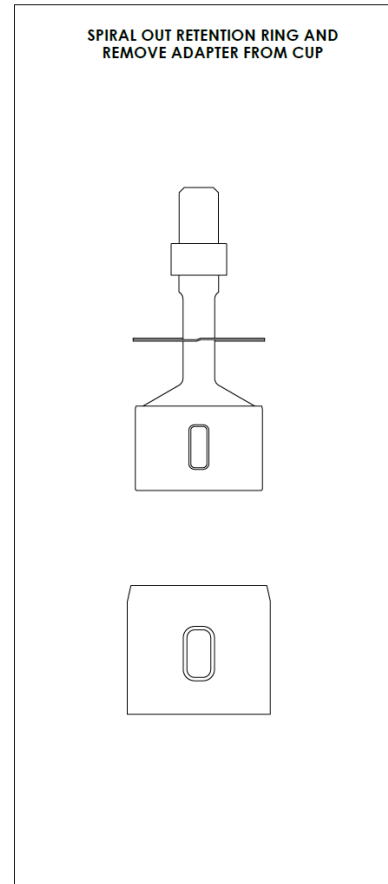
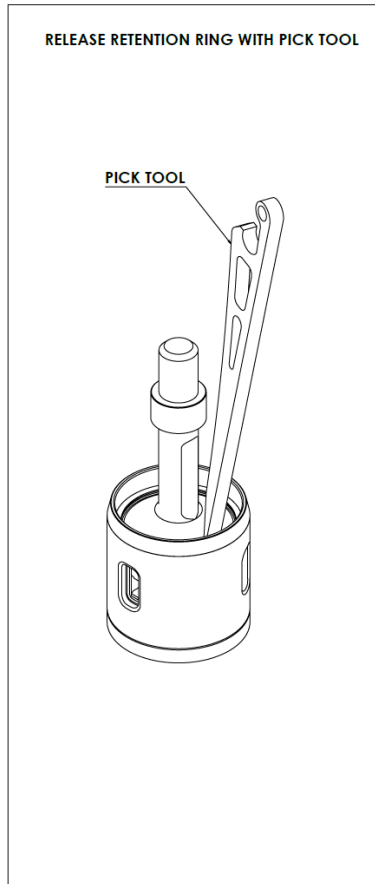
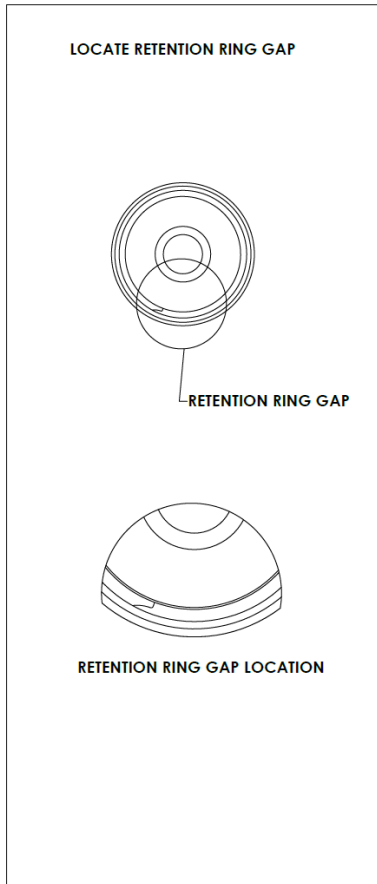

Field Customization of Slickline Adapters

The Slickline pucks and puck adapters are designed to be customized by the user if necessary to obtain a custom impact face diameter that is smaller than the adapter and puck size. Consult Table 3 of this manual to select the cup and adapter to start with to achieve a custom size.

The adapter diameter may be reduced by machining the flange of the adapter, and the puck diameter may be reduced by sanding only. 120-220 grit sandpaper on a belt sander is the recommended method to reduce the puck diameter.

! *CAUTION*** Only the flange of the adapter may be machined down (see figure below). NEVER machine the side wall of either an adapter or the cup as this will cause failure of the tool.**

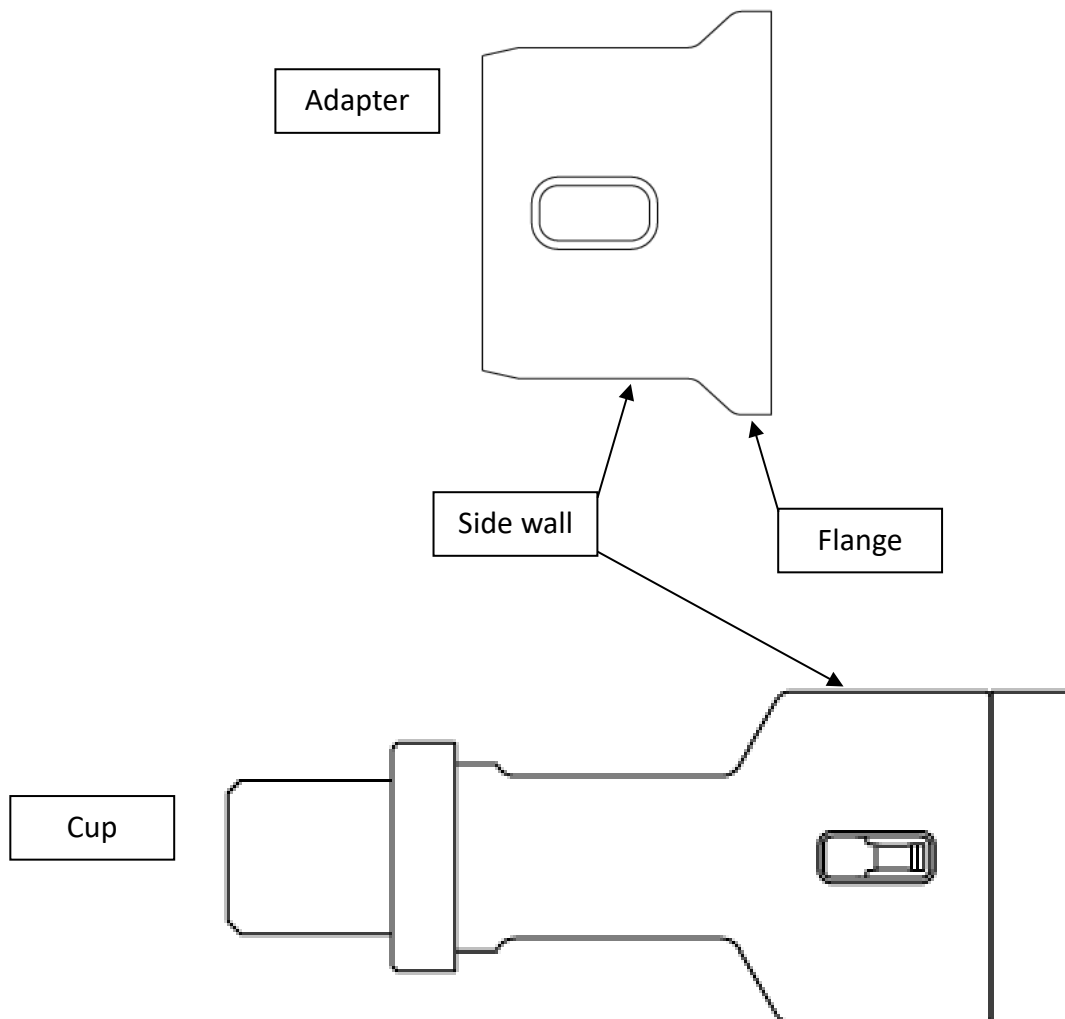

Also, a unique Slickline cup was designed to cover the smallest OD size range of 1.50" to 1.75" (SKU #000002 – see below). It is the only cup that also has a flange on the cup itself, rather than on an adapter. This flange can be machined back, just like the adapter flange, to provide a custom size, as needed.

! **Just as with the other cups and adapters, the side wall cannot be machined, only the flange portion of the cup. Machining of the side wall will cause the cup to fail.**

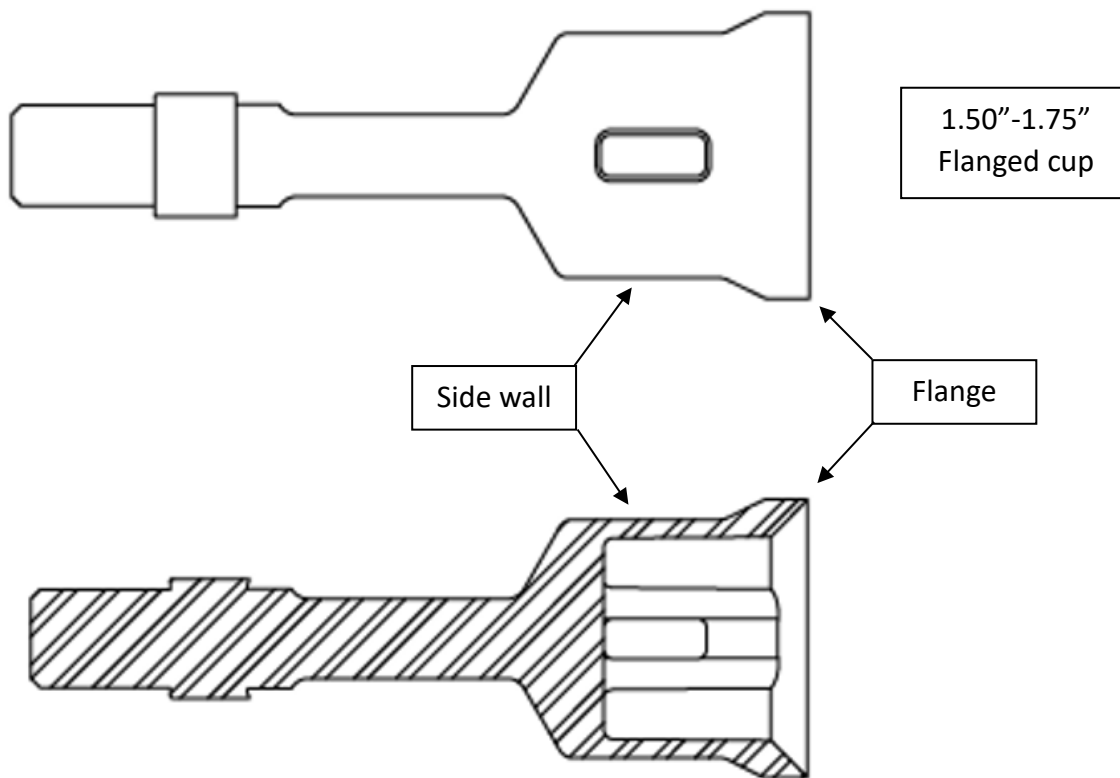

Maximum Allowable Tension for Slickline Adapters

When an adapter is used on a Slickline cup, the cup assembly is then subject to a maximum allowable tension (pull-back) force. For example, if the cup assembly becomes stuck in the tubing due to scale, application of cable pull, or jarring may be required to dislodge it.

The retention ring connection is the weak point in the cup assembly and care must be used to not exceed its pull load. Corrosion of the adapter groove or the ring may reduce the maximum allowable pull. Corroded adapters or rings should be replaced to prevent failure.

See Table 1 below for the maximum pull force that may be applied to each cup size and note the associated 2X to 3X safety factor for these values. For further information on allowable pull forces, contact the manufacturer.

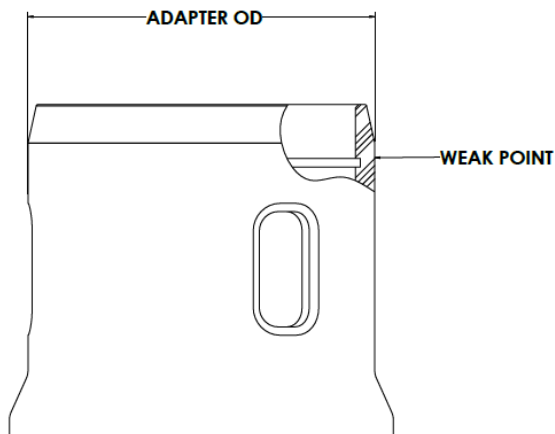

CORE SIZE	ADAPTER OD RANGE	MAX PULL LOAD
INCHES	INCHES	SAFETY FACTOR 2X-3X
1.25"	1.75" to 2.25"	10,000 LBS
1.75"	2.25" to 2.75"	12,000 LBS
2.25"	2.75" to 3.25"	16,000 LBS
2.75"	3.25" to 3.75"	24,000 LBS
3.25"	3.75" to 4.25"	18,000 LBS
3.75"	4.25" to 4.75"	20,000 LBS
4.25"	4.75" to 5.25"	26,000 LBS
4.75"	5.25" to 5.75"	28,000 LBS
5.25"	5.75" to 6.25"	42,000 LBS
ALL OTHER SIZES CONTACT MANUFACTURER		

Table 1 Max pull load table for Slickline cup and adapter assemblies

Ordering Standard Sizes, Part Numbers and Accessories

One functional unit of the Impressive Block™ system is considered a cup, a matching-sized puck, an adapter with retention ring if needed (*Slickline only*), and a pick tool with leather sheath and tool tether. These can either be purchased separately, or as a kit (see Table 2).

When an adapter is purchased, one new stainless steel retaining ring is provided. Also, when a set of Slickline pucks that require an adapter are purchased, one new retaining ring is included with the pucks (adapter retaining rings are recommended to be replaced when starting a new box of pucks). Additional retaining rings may be purchased separately for each adapter size, as desired.

The Impressive Block™ system is offered in standard sizes from 1.50” to 5.25” (see Tables 2, 3 and 4 below).

Standard sizes for cups begin at 1.50” and step up in 0.50” increments for Slickline (SL), and are custom engineered sizes for Tubing Conveyed beginning from 1.56”. Each cup has a corresponding “core size” which is the internal diameter (ID) of the cup where the puck is inserted.

Custom impact face sizes within this range are available, as well as different connections – provide the desired impact face diameter and connection size/type with your order and a detailed quote will be returned. However, for lower cost and faster availability, the Slickline adapters and pucks are designed to be custom sized in the field as discussed in an earlier section.

The impact face is normally full OD of the tool. If the impact face diameter is desired to be different, please communicate that in your order.

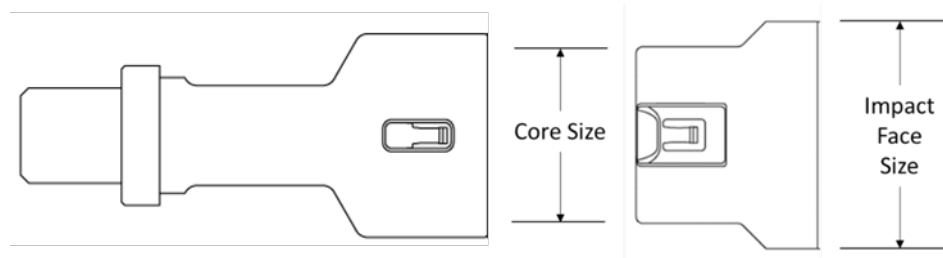

See the examples below to understand how to order the cups and adapters to achieve a desired size of impact face OD.



Slickline Only – Parts Selection for Custom Sizes

For enhanced flexibility and reduced system cost, one cup has the ability to fit multiple puck impact face sizes, with matching core diameters by the use of adapters.

! To order the correct parts, it is critical to match the desired impact face OD with the cup and adapter that can provide that size.

The examples below show how to select parts for standard sizes and also for custom sized impact faces.

In the first example below, for a 2.00” impact face OD, only the 1.75” core size cup (SKU-000003) and the 2.00” puck (SKU-000108) are required.

Desired Impact Face OD or Range (in)	Cup or Adapter Ring	Cup/ Adapter SKU #	Standard Connection	Fish Neck Diameter (in)	Overall Length (in)	Makeup Length (in)	Impression Puck Pack SKU #	Puck Count per Pack
1.50"	Cup - SL - 01.25" Core	000001	5/8"-11 UNC-2A	1.000	4.89	3.51	000104	6
1.50-1.75"	Cup - SL - 01.25" Core-01.75" Face-Flanged	000002	5/8"-11 UNC-2A	1.000	5.17	3.79	000105	6
1.75"	Adapter Ring - 01.25" Core - 01.75" Face	000017	-	-	5.17	3.79	000105	6
1.75-2.00"	Adapter Ring - 01.25" Core - 02.00" Face	000018	-	-	5.29	3.91	000106	6
1.75-2.25"	Adapter Ring - 01.25" Core - 02.25" Face	000019	-	-	5.42	4.04	000107	6
2.00"	Cup - SL - 01.75" Core	000003	5/8"-11 UNC-2A	1.187	5.03	3.65	000108	6
2.25"	Adapter Ring - 01.75" Core - 02.25" Face	000020	-	-	5.31	3.93	000109	6
2.25-2.50"	Adapter Ring - 01.75" Core - 02.50" Face	000021	-	-	5.44	4.06	000110	4
2.25-2.75"	Adapter Ring - 01.75" Core - 02.75" Face	000022	-	-	5.56	4.18	000111	4
2.50"	Cup - SL - 02.25" Core	000004	15/16"-10 UNS (5/8" SR)	1.375	5.44	3.69	000112	4





In the next example shown below, three SKUs are required for an assembly to run a 2.25" impact face puck in a 1.75" core cup.

Desired Impact Face OD or Range (in)	Cup or Adapter Ring	Cup/ Adapter SKU #	Standard Connection	Fish Neck Diameter (in)	Overall Length (in)	Makeup Length (in)	Impression Puck Pack SKU #	Puck Count per Pack
1.50"	Cup - SL - 01.25" Core	000001	5/8"-11 UNC-2A	1.000	4.89	3.51	000104	6
1.50-1.75"	Cup - SL - 01.25" Core-01.75" Face-Flanged	000002	5/8"-11 UNC-2A	1.000	5.17	3.79	000105	6
1.75"	Adapter Ring - 01.25" Core - 01.75" Face	000017	-	-	5.17	3.79	000105	6
1.75-2.00"	Adapter Ring - 01.25" Core - 02.00" Face	000018	-	-	5.29	3.91	000106	6
1.75-2.25"	Adapter Ring - 01.25" Core - 02.25" Face	000019	-	-	5.42	4.04	000107	6
2.00"	Cup - SL - 01.75" Core	000003	5/8"-11 UNC-2A	1.187	5.03	3.65	000108	6
2.25"	Adapter Ring - 01.75" Core - 02.25" Face	000020	-	-	5.31	3.93	000109	6
2.25-2.50"	Adapter Ring - 01.75" Core - 02.50" Face	000021	-	-	5.44	4.06	000110	4
2.25-2.75"	Adapter Ring - 01.75" Core - 02.75" Face	000022	-	-	5.56	4.18	000111	4
2.50"	Cup - SL - 02.25" Core	000004	15/16"-10 UNS (5/8" SR)	1.375	5.44	3.69	000112	4





However, in the example shown below, to run a custom impact face size that is 2.10”, you must order the 1.50” core cup, its largest adapter of 2.25” and the corresponding puck. The 2.25” adapter and the puck can then be modified by the recommended process to result in the 2.10” impact face OD.

Desired Impact Face OD or Range (in)	Cup or Adapter Ring	Cup/ Adapter SKU #	Standard Connection	Fish Neck Diameter (in)	Overall Length (in)	Makeup Length (in)	Impression Puck Pack SKU #	Puck Count per Pack
1.50"	Cup - SL - 01.25" Core	000001	5/8"-11 UNC-2A	1.000	4.89	3.51	000104	6
1.50-1.75"	Cup - SL - 01.25" Core - 01.75" Face-Flanged	000002	5/8"-11 UNC-2A	1.000	5.17	3.79	000105	6
1.75"	Adapter Ring - 01.25" Core - 01.75" Face	000017	-	-	5.17	3.79	000105	6
1.75-2.00"	Adapter Ring - 01.25" Core - 02.00" Face	000018	-	-	5.29	3.91	000106	6
1.75-2.25"	Adapter Ring - 01.25" Core - 02.25" Face	000019	-	-	5.42	4.04	000107	6
2.00"	Cup - SL - 01.75" Core	000003	5/8"-11 UNC-2A	1.187	5.03	3.65	000108	6
2.25"	Adapter Ring - 01.75" Core - 02.25" Face	000020	-	-	5.31	3.93	000109	6
2.25-2.50"	Adapter Ring - 01.75" Core - 02.50" Face	000021	-	-	5.44	4.06	000110	4
2.25-2.75"	Adapter Ring - 01.75" Core - 02.75" Face	000022	-	-	5.56	4.18	000111	4
2.50"	Cup - SL - 02.25" Core	000004	15/16"-10 UNS (5/8" SR)	1.375	5.44	3.69	000112	4

If you have questions or are unclear how to order the impact face size desired, please submit your desired impact face size and a connection type and a full quote will be returned for your review.



Slickline Cup ordering info:

These Slickline kits are an economical way to cover all the standard sizes within your tubing range.

Table 2. Slickline Starter Kits – Lower Cost to Get Started.

Slickline Kit Description	Kit SKU	Kit Contents
Slickline Kit - 1.50"-2.25"	000210	1.50" SL Cup, 1.75" SL cup, adapters (1.75", 2.00" and 2.25"), Pick Tool, 1 box each size of pucks w/rings
Slickline Kit - 2.00"-2.75"	000211	2.00" SL Cup, Adapters (2.25", 2.50" and 2.75"), Pick Tool, 1 box each size of pucks w/rings
Slickline Kit - 2.50"-3.25"	000212	2.50" SL Cup, Adapters (2.75", 3.00" and 3.25"), Pick Tool, 1 box each size of pucks w/rings
Slickline Kit - 3.00"-3.75"	000213	3.00" SL Cup, Adapters (3.25", 3.50" and 3.75"), Pick Tool, 1 box each size of pucks w/rings
Slickline Kit - 3.50"-4.25"	000214	3.50" SL Cup, Adapters (3.75", 4.00" and 4.25"), Pick Tool, 1 box each size of pucks w/rings
Slickline Kit - 4.00"-4.75"	000215	4.00" SL Cup, Adapters (4.25", 4.50" and 4.75"), Pick Tool, 1 box each size of pucks w/rings
Slickline Kit - 4.50"-5.25"	000216	4.50" SL Cup, Adapters (4.75", 5.00" and 5.25"), Pick Tool, 1 box each size of pucks w/rings



Table 3. Slickline standard size part chart. Other sizes and connections available as custom.

Desired Impact Face OD or Range (in)	Cup or Adapter Ring	Cup/ Adapter SKU #	Standard Connection	Fish Neck Diameter (in)	Overall Length (in)	Makeup Length (in)	Impression Puck Pack SKU #	Puck Count per Pack
1.50"	Cup - SL - 01.25" Core	000001	5/8"-11 UNC-2A	1.000	4.89	3.51	000104	6
1.50-1.75"	Cup - SL - 01.25" Core - 01.75" Face-Flanged	000002	5/8"-11 UNC-2A	1.000	5.17	3.79	000105	6
1.75"	Adapter Ring - 01.25" Core - 01.75" Face	000017	-	-	5.17	3.79	000105	6
1.75-2.00"	Adapter Ring - 01.25" Core - 02.00" Face	000018	-	-	5.29	3.91	000106	6
1.75-2.25"	Adapter Ring - 01.25" Core - 02.25" Face	000019	-	-	5.42	4.04	000107	6
2.00"	Cup - SL - 01.75" Core	000003	5/8"-11 UNC-2A	1.187	5.03	3.65	000108	6
2.25"	Adapter Ring - 01.75" Core - 02.25" Face	000020	-	-	5.31	3.93	000109	6
2.25-2.50"	Adapter Ring - 01.75" Core - 02.50" Face	000021	-	-	5.44	4.06	000110	4
2.25-2.75"	Adapter Ring - 01.75" Core - 02.75" Face	000022	-	-	5.56	4.18	000111	4
2.50"	Cup - SL - 02.25" Core	000004	15/16"-10 UNS (5/8" SR)	1.375	5.44	3.69	000112	4
2.75"	Adapter Ring - 02.25" Core - 02.75" Face	000023	-	-	5.72	3.97	000113	4
2.75-3.00"	Adapter Ring - 02.25" Core - 03.00" Face	000024	-	-	5.84	4.09	000114	4
2.75-3.25"	Adapter Ring - 02.25" Core - 03.25" Face	000025	-	-	5.97	4.22	000115	4
3.00"	Cup - SL - 02.75" Core	000005	1-1/16"-10 UNS (3/4" SR)	1.75	5.92	3.79	000116	4
3.25"	Adapter Ring - 02.75" Core - 03.25" Face	000026	-	-	6.20	4.08	000117	4
3.25-3.50"	Adapter Ring - 02.75" Core - 03.50" Face	000027	-	-	6.33	4.20	000118	4
3.25-3.75"	Adapter Ring - 02.75" Core - 03.75" Face	000028	-	-	6.45	4.33	000119	4
3.50"	Cup - SL - 03.25" Core	000006	1-1/16"-10 UNS (3/4" SR)	2.312	6.06	3.94	000120	4
3.75"	Adapter Ring - 03.25" Core - 03.75" Face	000029	-	-	6.35	4.22	000121	4
3.75-4.00"	Adapter Ring - 03.25" Core - 04.00" Face	000030	-	-	6.47	4.35	000122	2
3.75-4.25"	Adapter Ring - 03.25" Core - 04.25" Face	000031	-	-	6.60	4.47	000123	2
4.00"	Cup - SL - 03.75" Core	000007	1-9/16"-10 UNS (1-1/8" SR)	2.312	6.21	4.08	000124	2
4.25"	Adapter Ring - 03.75" Core - 04.25" Face	000032	-	-	6.49	4.37	000125	2
4.25-4.50"	Adapter Ring - 03.75" Core - 04.50" Face	000033	-	-	6.62	4.49	000126	2
4.25-4.75"	Adapter Ring - 03.75" Core - 04.75" Face	000034	-	-	6.74	4.62	000127	2



Table 3 (cont). Slickline standard size part chart. Other sizes and connections available as custom.

Desired Impact Face OD or Range (in)	Cup and Adapter (cups come w/ 1 pick tool each)	Cup/ Adapter SKU #	Standard Connection	Fish Neck Diameter (in)	Overall Length (in)	Makeup Length (in)	Impression Puck Pack SKU #	Puck Count per Pack
4.50"	Cup - SL - 04.25" Core	000008	1-9/16"-10 UNS (1-1/8" SR)	3.125	6.35	4.23	000128	2
4.75"	Adapter Ring - 04.25" Core - 04.75" Face	000035	-	-	6.64	4.51	000129	2
4.75-5.00"	Adapter Ring - 04.25" Core - 05.00" Face	000036	-	-	6.76	4.64	000130	2
4.75-5.25"	Adapter Ring - 04.25" Core - 05.25" Face	000037	-	-	6.89	4.76	000131	2

Table 4. Retaining ring sizing and ordering chart*.

Desired Impact Face OD or Range (in)	Cup or Adapter Ring	Retaining Ring SKU	Retaining Ring Description	Count of Rings per Pack
1.50"	Cup - SL - 01.25" Core	-	-	-
1.50-1.75"	Cup - SL - 01.25" Core-01.75" Face-Flanged	-	-	-
1.75"	Adapter Ring - 01.25" Core - 01.75" Face	000225	Retaining Ring - Internal - 01.50" OD - Medium Heavy Duty	10
1.75-2.00"	Adapter Ring - 01.25" Core - 02.00" Face			
1.75-2.25"	Adapter Ring - 01.25" Core - 02.25" Face			
2.00"	Cup - SL - 01.75" Core	-	-	-
2.25"	Adapter Ring - 01.75" Core - 02.25" Face	000226	Retaining Ring - Internal - 02.00" OD - Medium Duty	10
2.25-2.50"	Adapter Ring - 01.75" Core - 02.50" Face			
2.25-2.75"	Adapter Ring - 01.75" Core - 02.75" Face			
2.50"	Cup - SL - 02.25" Core	-	-	-
2.75"	Adapter Ring - 02.25" Core - 02.75" Face	000227	Retaining Ring - Internal - 02.50" OD - Medium Duty	10
2.75-3.00"	Adapter Ring - 02.25" Core - 03.00" Face			
2.75-3.25"	Adapter Ring - 02.25" Core - 03.25" Face			
3.00"	Cup - SL - 02.75" Core	-	-	-
3.25"	Adapter Ring - 02.75" Core - 03.25" Face	000228	Retaining Ring - Internal - 03.00" OD - Medium Duty	10
3.25-3.50"	Adapter Ring - 02.75" Core - 03.50" Face			
3.25-3.75"	Adapter Ring - 02.75" Core - 03.75" Face			
3.50"	Cup - SL - 03.25" Core	-	-	-
3.75"	Adapter Ring - 03.25" Core - 03.75" Face	000229	Retaining Ring - Internal - 03.50" OD - Light Duty	10
3.75-4.00"	Adapter Ring - 03.25" Core - 04.00" Face			
3.75-4.25"	Adapter Ring - 03.25" Core - 04.25" Face			
4.00"	Cup - SL - 03.75" Core	-	-	-
4.25"	Adapter Ring - 03.75" Core - 04.25" Face	000230	Retaining Ring - Internal - 04.00" OD - Light Duty	10
4.25-4.50"	Adapter Ring - 03.75" Core - 04.50" Face			
4.25-4.75"	Adapter Ring - 03.75" Core - 04.75" Face			
4.50"	Cup - SL - 04.25" Core	-	-	-
4.75"	Adapter Ring - 04.25" Core - 04.75" Face	000231	Retaining Ring - Internal - 04.50" OD - Light Duty	10
4.75-5.00"	Adapter Ring - 04.25" Core - 05.00" Face			
4.75-5.25"	Adapter Ring - 04.25" Core - 05.25" Face			

*One retaining ring is provided with each new adapter and each new box of pucks.



Coil Tubing cup ordering info

Table 5. Coil Tubing standard size part chart. Other sizes and connections available as custom.

Coil Tubing cups are sold with the standard connection being a blank so that a user may machine to their requirements. To order with threads, see the standard connections available by the manufacturer. Pump-thru cup body is standard configuration.

Impact Face Dia (in)	Cup Description	Cup SKU	Standard Connection	Fish Neck Diameter	Overall Length (in)	Makeup Length (in)	Impression Puck SKU	Puck Count Per Pack
1.56"	Cup - TC - Blank - 1.56" OD Pump Thru	000062	Blank/1" AMT	1.53"	9.40	8.96	000164	6
1.64"	Cup - TC - Blank - 1.64" OD Pump Thru	000063	Blank/1" AMT	1.53"	9.68	9.24	000165	6
1.82"	Cup - TC - Blank - 1.82" OD Pump Thru	000064	Blank/1" AMT	1.63"	10.32	9.88	000166	6
1.97"	Cup - TC - Blank - 1.97" OD Pump Thru	000065	Blank/1" AMT	1.69"	10.86	10.42	000167	6
2.02"	Cup - TC - Blank - 2.02" OD Pump Thru	000066	Blank/1" AMT	1.69"	11.05	10.61	000168	6
2.10"	Cup - TC - Blank - 2.10" OD Pump Thru	000067	Blank/1" AMT	1.69"	11.10	10.66	000169	6
2.29"	Cup - TC - Blank - 2.29" OD Pump Thru	000068	Blank/1" AMT	1.69"	11.81	11.37	000170	6
2.67"	Cup - TC - Blank - 2.67" OD Pump Thru	000069	Blank/1"AMT/1-1/2" AMT	2.13"	13.50	13.06	000171	4
2.81"	Cup - TC - Blank - 2.81" OD Pump Thru	000070	Blank/1"AMT/1-1/2" AMT	2.13"	14.03	13.59	000172	4
2.99"	Cup - TC - Blank - 2.99" OD Pump Thru	000071	Blank/1"AMT/1-1/2" AMT	2.13"	14.72	14.28	000173	4
3.09"	Cup - TC - Blank - 3.09" OD Pump Thru	000072	Blank/1"AMT/1-1/2" AMT	2.13"	14.98	14.54	000174	4
3.17"	Cup - TC - Blank - 3.17" OD Pump Thru	000073	Blank/1"AMT/1-1/2" AMT	2.13"	15.29	14.85	000175	4
3.29"	Cup - TC - Blank - 3.29" OD Pump Thru	000074	Blank/1"AMT/1-1/2" AMT/ 2-3/8" PAC	3.00"	15.55	15.17	000176	4
3.39"	Cup - TC - Blank - 3.39" OD Pump Thru	000075	Blank/1"AMT/1-1/2" AMT/ 2-3/8" PAC	3.00"	15.79	15.41	000177	4



Table 5 (cont). Tubing Conveyed standard size part chart. Other sizes and connections available as custom.

Impact Face Dia (in)	Cup Description	Cup SKU	Standard Connection	Fish Neck Diameter	Overall Length (in)	Makeup Length (in)	Impression Puck SKU	Puck Count Per Pack
3.49"	Cup - TC - Blank - 3.49" OD Pump Thru	000076	Blank/1"AMT/1-1/2" AMT/ 2-3/8" PAC	3.00"	16.17	15.79	000178	4
3.57"	Cup - TC - Blank - 3.57" OD Pump Thru	000077	Blank/1"AMT/1-1/2" AMT/ 2-3/8" PAC/ 2-3/8" REG	3.25"	17.16	16.53	000179	4
3.67"	Cup - TC - Blank - 3.67" OD Pump Thru	000078	Blank/1"AMT/1-1/2" AMT/ 2-3/8" PAC/ 2-3/8" REG	3.25"	17.53	16.90	000180	4
3.75"	Cup - TC - Blank - 3.75" OD Pump Thru	000079	Blank/1"AMT/1-1/2" AMT/ 2-3/8" PAC/ 2-3/8" REG	3.25"	17.83	17.20	000181	4
3.80"	Cup - TC - Blank - 3.80" OD Pump Thru	000080	Blank/1"AMT/1-1/2" AMT/ 2-3/8" PAC/ 2-3/8" REG	3.25"	18.02	17.39	000182	4
3.84"	Cup - TC - Blank - 3.84" OD Pump Thru	000081	Blank/1"AMT/1-1/2" AMT/ 2-3/8" PAC/ 2-3/8" REG	3.25"	18.17	17.54	000183	4
4.02"	Cup - TC - Blank - 4.02" OD Pump Thru	000082	Blank/1"AMT/1-1/2" AMT/ 2-3/8" PAC/ 2-3/8" REG	3.25"	18.73	18.10	000184	2
4.15"	Cup - TC - Blank - 4.15" OD Pump Thru	000083	Blank/1"AMT/1-1/2" AMT/ 2-3/8" PAC/ 2-3/8" REG	3.25"	19.23	18.60	000185	2
4.31"	Cup - TC - Blank - 4.31" OD Pump Thru	000084	Blank/1"AMT/1-1/2" AMT/ 2-3/8" PAC/ 2-3/8" REG	3.25"	19.72	19.09	000186	2
4.42"	Cup - TC - Blank - 4.42" OD Pump Thru	000085	Blank/1"AMT/1-1/2" AMT/ 2-3/8" PAC/ 2-3/8" REG	3.25"	20.15	19.52	000187	2
4.64"	Cup - TC - Blank - 4.64" OD Pump Thru	000086	Blank/1"AMT/1-1/2" AMT/ 2-3/8" PAC/ 2-3/8" REG	3.25"	20.89	20.26	000188	2
4.70"	Cup - TC - Blank - 4.70" OD Pump Thru	000087	Blank/1"AMT/1-1/2" AMT/ 2-3/8" PAC/ 2-3/8" REG	3.25"	21.00	20.37	000189	2



Table 5. Pick Tool ordering options.

Description	SKU
Pick Tool with leather sheath and tool tether	000207
Pick Tool	000206
Leather Sheath	000208
Tool tether	000209

Warranty:

The manufacturer warranty’s the Impressive Block™ pucks to be free of defects of material and workmanship for 3 years. Check date code on original puck shipping box for puck age. Date code is “XXYYZZ” where XX equals the year of production, YY equals the month, ZZ equals the day.

This warranty does not cover damage due to shipping, handling, damage from improper storage or stacking as well as extended storage outside of the prescribed temperature conditions noted above. The conditions of this warranty are valid for all States, nations and territories except where it is not allowed by law.

---ENDS