



BUILT TO WORK. BUILT TO LAST.

CM
TRUCK BEDS®

STEEL AND ALUMINUM TRUCK BEDS AND SERVICE BODIES

WWW.CMTRUCKBEDS.COM



BUILT TO WORK. BUILT TO LAST.

CM Truck Beds offers the industry's most rugged, durable and best-looking truck beds and service bodies. We're proud to be the product of choice for commercial fleets and work truck users. Whether you're looking for a steel flat bed, a specialty bed, a heavy-duty aluminum bed, or a versatile service body, CM Truck Beds has a product to meet your needs and exceed your expectations. Our diverse lineup will fit almost any cab and chassis or take-off body unit.



MOST OF OUR TRUCK BEDS AND SERVICE BODIES INCLUDE:

- Best-In-Class Rated B&W Trailer Hitches
- Premium TexArmor Powdercoat Finish (Steel Models)
- T-Handle Compression Toolbox Latches
- 3/8" Rubrail & Stake Pockets on Many Models
- Optronics LED Lighting with Lifetime Warranty
- Plug & Play Modular Sealed Wiring Harness
- 1/8" Steel Treadplate Decking
- 3" Steel Crossmembers
- Service Bodies Feature Component-Style Configuration
 - Easier to Customize, Maintain and Repair

With the best on-hand inventory, exceptional lead times and industry-leading quality, count on CM Truck Beds as the platform for your success, now and long into the future.

THE DIFFERENCE IS CLEAR

OUR ENGINEERS WORK HARD TO ADAPT TO THE EVER-CHANGING STYLES OF OEM CHASSIS MANUFACTURERS, SO YOU'RE NOT JUST GETTING DURABILITY, BUT ALSO OPTIMUM USABILITY. QUITE SIMPLY, WE'RE COMMITTED TO PROVIDING A LEVEL OF QUALITY YOU CAN FEEL GREAT ABOUT, AT A VALUE THAT'S UNSURPASSED.

BEST-IN-CLASS RATED B&W HITCHES

While some manufacturers install hitches that are untested, CM Truck Beds come standard with B&W hitches that are proven to withstand the heavy loads our beds tow. Each attachment point comes with quality electrical connections, ensuring that you tow with safety first.



EXTRUDED ALUMINUM FLOORS (ALUMINUM MODELS)

How's this for tough: Our extruded aluminum floors have a weight rating of 800 pounds per square foot. Some say aluminum is weaker; we say they're just doing it wrong. (Not standard on AL ER Models.)



WARRANTY-PROTECTED LED LIGHTING

When safety counts, count on CM Truck Beds. We utilize the safest, easiest-to-maintain lights on the market. LED lights are brighter, light up instantaneously, make for easier maintenance, and come with a standard lifetime warranty.



SINGLE-PIECE SQUARE TUBE HEADACHE RACKS

Clearly the toughest, heaviest square tube headache racks in the business. You won't see breaks, cuts or pieced-together parts in our racks; built from a single piece, they're indestructible. When the unexpected occurs, count on our headache racks to keep you safe.



TEXARMOR POWDERCOAT FINISH (STEEL MODELS)

While other companies stick to paint, CM coats every steel product with a super-durable powdercoat primer followed by a high-gloss TexArmor powdercoat finish. We go under every edge and cover every crevice to ensure your truck bed is protected. This superior finish adds a shine that will last for many years.



3-PIECE PLUG & PLAY MODULAR SEALED WIRING HARNESS

We understand that our beds are exposed to harsh conditions that oftentimes cause wiring to corrode, pull apart or deteriorate. CM Truck Beds wiring harnesses are designed for durability in even the most challenging conditions.





SS

The sleek SS—CM's price-leading model—comes equipped with a best-in-class tubular steel headache rack, smooth side rails, and a solid one-piece rear skirt.

FEATURES AND OPTIONS

LENGTHS	84", 8'6", 9'4", 11'4"
HEADACHE RACK	Steel Tube
HEADACHE RACK LIGHTING	Clear LED Oval
DECK	1/8" Treadplate
FRAME RAILS	4" Structural Channel Steel
CROSSMEMBERS	3" x 3/16" Channel
REAR SKIRT	Solid One Piece with Tapered Corners
GN HITCH	30K B&W Hitch with Welded Ball
BP HITCH	18,500 lb. B&W Hitch with Receiver Tube
SIDE RAILS	Integrated Side Rails with Internal Stake Pockets

FUEL FILL	Angled
12V TRAILER PLUG	Round 7 Pin in GN Box, Round 7 Pin/4 Way Flat on Rear
REAR LIGHTING	Clear LED Oval
LIGHT BOX (REAR SKIRT)	Steel
MARKER LIGHTING	Bullet DOT Approved LED
TOOLBOX	Optional Underbody
TOOLBOX HANDLE	N/A
FENDERS	N/A
SIDESTEPS	N/A
TIE DOWNS	N/A

NOTABLE OPTIONS INCLUDE: 3/16" Heavy-Duty Deck; 30K B&W Hitch with Turnover Ball (required for 5th Wheel capability); Cargo Light; Drop-In or Fold-Down Side Rails; Gooseneck Trough; Rolling Tailboard Wood; Rubber or Blackwood Flooring; Underbody Toolbox



STEEL AND ALUMINUM TRUCK BEDS



Shown with Optional Underbody Toolbox

RD / AL RD

ALUMINUM

Tough enough to haul the big loads, the popular RD models are expertly designed, professional-grade workhorses that are sized to fit almost any unit.

	STEEL	ALUMINUM
LENGTHS	84", 8'6", 9'4", 11'4"	84", 8'6", 9'4", 11'4"
HEADACHE RACK	Steel Tube	Aluminum Tube
HEADACHE RACK LIGHTING	Clear LED Oval	Clear LED Oval
DECK	1/8" Treadplate	Extruded Aluminum Floor
FRAME RAILS	4" Structural Channel Steel	4" Structural Channel Steel
CROSSMEMBERS	3" x 3/16" Channel	3" x 3/16" Channel
REAR SKIRT	Solid One Piece with Tapered Corners	Solid One Piece with Tapered Corners
GN HITCH	30K B&W Hitch with Welded Ball	30K B&W Hitch with Welded Ball
BP HITCH	18,500 lb. B&W Hitch with Receiver Tube	18,500 lb. B&W Hitch with Receiver Tube
SIDE RAILS	3/8" x 2" Side Rails with Stake Pockets	3/8" x 2" Side Rails with Stake Pockets
FUEL FILL	Angled	Angled (Cast Aluminum)
12V TRAILER PLUG	Round 7 Pin in GN Box, Round 7 Pin/4 Way Flat on Rear	Round 7 Pin in GN Box, Round 7 Pin/4 Way Flat on Rear
REAR LIGHTING	Clear LED Oval	Clear LED Oval
LIGHT BOX (REAR SKIRT)	Steel	Aluminum
MARKER LIGHTING	Bullet DOT Approved LED	Bullet DOT Approved LED
TOOLBOX	Optional Underbody	Optional Underbody

FEATURES AND OPTIONS



NOTABLE OPTIONS INCLUDE: 3/16" Heavy-Duty Deck; 30K B&W Hitch with Turnover Ball (required for 5th Wheel capability); Cargo Light; Drop-In or Fold-Down Side Rails; Gooseneck Trough; Rolling Tailboard; Wood, Rubber or Blackwood Flooring; Underbody Toolbox; Aluminum Underbody Toolboxes (AL RD model)



SK / ALUMINUM

Top-notch features and hardware on the SK models include a best-in-class tubular headache rack, LED lighting, top-rated B&W hitches, and integrated toolboxes.



FEATURES AND OPTIONS

	STEEL	ALUMINUM
LENGTHS	84", 8'6", 9'4", 11'4"	84", 8'6", 9'4", 11'4"
HEADACHE RACK	Steel Tube	Aluminum Tube
HEADACHE RACK LIGHTING	Clear LED Oval	Clear LED Oval
DECK	1/8" Treadplate	Extruded Aluminum Floor
FRAME RAILS	4" Structural Channel Steel	4" Structural Channel Steel
CROSSMEMBERS	3" x 3/16" Channel	3" x 3/16" Channel
REAR SKIRT	Solid One Piece with Rear Step	Solid One Piece with Rear Step
GN HITCH	30K B&W Hitch with Welded Ball	30K B&W Hitch with Welded Ball
BP HITCH	18,500 lb. B&W Hitch with Receiver Tube	18,500 lb. B&W Hitch with Receiver Tube
SIDE RAILS	3/8" x 2" Side Rails with Stake Pockets	3/8" x 2" Side Rails with Stake Pockets
FUEL FILL	Angled	Angled (Cast Aluminum)
12V TRAILER PLUG	Round 7 Pin in GN Box, Round 7 Pin/4 Way Flat on Rear	Round 7 Pin in GN Box, Round 7 Pin/4 Way Flat on Rear
REAR LIGHTING	Clear LED Oval	Clear LED Oval
LIGHT BOX (REAR SKIRT)	Steel	Aluminum
MARKER LIGHTING	Bullet DOT Approved LED	Bullet DOT Approved LED
TOOLBOX	(4) Standard Integrated	(4) Standard Integrated
TOOLBOX HANDLE	Chrome T Handle Compression	Black T Handle Compression
FENDERS	Steel Radius	Aluminum Radius
SIDESTEPS	Integrated Front to Rear	Aluminum Steps Integrated Front to Rear

NOTABLE OPTIONS INCLUDE: 3/16" Heavy-Duty Deck; 30K B&W Hitch with Turnover Ball (required for 5th Wheel capability); Color Primer Only (SK model); Dovetail Deck; Drop-In or Fold-Down Side Rails; Gooseneck Trough; Rear Rubrail; Stainless Fenders (SK model); Wood, Rubber or Blackwood Flooring



STEEL AND ALUMINUM TRUCK BEDS



ER ALUMINUM

For impressive durability, great functionality and eye-catching design with zero tradeoffs, the stylish ER models are the smart choice for your hauling needs.

	STEEL	ALUMINUM
LENGTHS	84", 8'6", 9'4", 11'4"	84", 8'6", 9'4", 11'4"
HEADACHE RACK	Steel Tube	One-Piece Aluminum Square Tube
HEADACHE RACK LIGHTING	Clear LED Oval w/Chrome Housing	Clear LED Oval w/Chrome Housing
DECK	1/8" Treadplate	1/8" Aluminum Treadplate
FRAME RAILS	4" Structural Channel Steel	4" Structural Channel Steel
CROSSMEMBERS	3" x 3/16" Channel	3" x 3/16" Channel
REAR SKIRT	Solid One Piece with Rear Step	Solid One Piece with Rear Step
GN HITCH	30K B&W Hitch with Welded Ball in Trough	30K B&W Hitch with Welded Ball in Trough
BP HITCH	18,500 lb. B&W Hitch with Receiver Tube	18,500 lb. B&W Hitch with Receiver Tube
SIDE RAILS	Raised Side Rail with Aluminum Cap	Raised Side Rail with Aluminum Cap
FUEL FILL	Angled (Cast Aluminum)	Angled (Cast Aluminum)
12V TRAILER PLUG	Round 7 Pin in GN Box, Round 7 Pin/4 Way Flat on Rear	Round 7 Pin in GN Box, Round 7 Pin/4 Way Flat on Rear
REAR LIGHTING	Clear LED Oval with Chrome Housing	Clear LED Oval with Chrome Housing
LIGHT BOX (REAR SKIRT)	Cast Aluminum	Cast Aluminum
MARKER LIGHTING	Bullet DOT Approved LED	Bullet DOT Approved LED
TOOLBOX	(4) Standard Integrated	(4) Standard Integrated
TOOLBOX HANDLE	Chrome T Handle Compression	Black T Handle Compression
FENDERS	Chrome Radius	Chrome Radius
SIDESTEPS	Integrated Front to Rear	Aluminum Steps Integrated Front to Rear
TIE DOWNS	(4) 18" Airline Track Tiedowns (4) Attachment Rings	(4) 18" Airline Track Tiedowns (4) Attachment Rings

FEATURES AND OPTIONS



NOTABLE OPTIONS INCLUDE: 3/16" Heavy-Duty Deck; 30K B&W Hitch with Turnover Ball (required for 5th Wheel capability); Bale Spikes (ER model); Cargo Lights; Color Primer Only (ER model)



PL / PLS

The PL and PLS models are platform bodies with an edge, featuring the strongest, most durable materials on the market with best-in-class features to get the job done.



FEATURES AND OPTIONS

	PL	PLS
LENGTHS	10'-18' = Standard Duty 20'-24' = Heavy Duty	10'-18'
HEADACHE RACK	Formed Bulkhead with Punched Grill	Bolt-On Headache Rack and Ship-Through Corners
DECK	10'-18' = 1/8" Treadplate 20'-24' = 3/16" Treadplate	1/8" Treadplate
FRAME RAILS	10'-18' = 4" Structural Channel Steel 20'-24' = 8" Channel Steel	4" Structural Channel Steel
CROSSMEMBERS	10'-18' = 3" x 3/16" Channel 20'-24' = 4" Channel Steel	3" x 3/16" Channel
BP HITCH	ICC Optional	ICC Optional
SIDE RAILS	3/8" x 2" Side Rails with Stake Pockets	Smooth Sides w/ Internal Stake Pockets
MARKER LIGHTING	Bullet DOT Approved LED	Bullet DOT Approved LED
TOOLBOX	Optional Underbody	Optional Underbody

NOTABLE OPTIONS INCLUDE: 3/16" Heavy-Duty Deck; 30K B&W Hitch with Turnover Ball (required for 5th Wheel capability); Bale Spikes, Cargo Light; Color Primer Only; Front Underbody Toolbox; Stake Sides; Wood, Rumber or Blackwood Flooring



AL PL
ALUMINUM

Take uncertainty out of the equation with CM's AL PL model: Strong and durable yet lightweight and efficient, this aluminum platform body is reliable through-and-through.

LENGTHS	10'-18' = Standard Duty
HEADACHE RACK	Aluminum Tube
DECK	Extruded Aluminum Floor
FRAME RAILS	4" Aluminum Channel
CROSSMEMBERS	3" Aluminum Channel

REAR SKIRT	One Piece Aluminum
BP HITCH	ICC Optional
SIDE RAILS	3/8" x 2" Side Rails with Stake Pockets
MARKER LIGHTING	Bullet DOT Approved LED
TOOLBOX	Optional Underbody

FEATURES AND OPTIONS

NOTABLE OPTIONS INCLUDE: Aluminum Underbody Toolboxes; Wood, Rumber or Blackwood Flooring



TM

The TM is America's ultimate Towing-Style utility body, with smart, ready-to-work features including a full-width tailgate and full-length shovel box.

Photo shows optional work lights

FEATURES AND OPTIONS

LENGTHS	84", 8'6", 9'4", 11'4"
HEADACHE RACK	Steel Tube
HEADACHE RACK LIGHTING	Clear LED Oval
DECK	1/8" Treadplate
FRAME RAILS	4" Structural Channel Steel
CROSSMEMBERS	3" x 3/16" Channel
REAR SKIRT	Solid One Piece with Rear Step
GN HITCH	30K B&W Hitch with Welded Ball
BP HITCH	18,500 lb. B&W Hitch with Receiver Tube
SIDE RAILS	N/A

FUEL FILL	Angled
12V TRAILER PLUG	Round 7 Pin in GN Box, Round 7 Pin/4 Way Flat on Rear
REAR LIGHTING	Clear LED Oval
LIGHT BOX (REAR SKIRT)	Steel
MARKER LIGHTING	Bullet DOT Approved LED
TOOLBOX	Utility Box in Front, Top-Open 3/4 Length Shovel Box; Low-Profile Chain Bx in Rear
TOOLBOX HANDLE	Chrome T Handle Compression
FENDERS	Steel Welded-In
SIDESTEPS	Integrated Front to Rear
TIE DOWNS	18" Airline Track Tiedowns, (4) Attachment Rings

NOTABLE TM OPTIONS INCLUDE: 3/16" Heavy-Duty Deck; 30K B&W Hitch with Turnover Ball (required for 5th Wheel capability); Bale Spikes; Color Primer Only; Stainless Fenders; Work Lights (pictured)



STEEL AND ALUMINUM TRUCK BEDS



TM / TMX

DELUXE

The TM Deluxe is designed to haul trailers from bumper or gooseneck positions and features an opossum belly, work lights and a tall rear toolbox. And with its 48"-wide deck, the TMX is the best solution for single-wheel chassis.

	TM DELUXE	TMX
LENGTHS	84", 8'6", 9'4", 11'4"	84", 8'6", 9'4", 11'4"
HEADACHE RACK	Steel Tube	Steel Tube
HEADACHE RACK LIGHTING	Clear LED Oval	Clear LED Oval
DECK	1/8" Treadplate	1/8" Treadplate
FRAME RAILS	4" Structural Channel Steel	4" Structural Channel Steel
CROSSMEMBERS	3" x 3/16" Channel	3" x 3/16" Channel
REAR SKIRT	Solid One Piece with Rear Step	Solid One Piece with Rear Step
GN HITCH	30K B&W Hitch with Welded Ball	30K B&W Hitch with Welded Ball
BP HITCH	18,500 lb. B&W Hitch with Receiver Tube	18,500 lb. B&W Hitch with Receiver Tube
SIDE RAILS	N/A	N/A
FUEL FILL	Angled	Angled
12V TRAILER PLUG	Round 7 Pin in GN Box, Round 7 Pin/4 Way Flat on Rear	Round 7 Pin in GN Box, Round 7 Pin/4 Way Flat on Rear
REAR LIGHTING	Clear LED Oval	Clear LED Oval
LIGHT BOX (REAR SKIRT)	Steel	Steel
MARKER LIGHTING	Bullet DOT Approved LED	Bullet DOT Approved LED
TOOLBOX	Utility Box in front; Top-Open 1/2 Length Shovel Box; Tall Chain Box in rear; Opossum Belly	Utility Box in front; Top-Open 3/4 Length Shovel Box; Low-Profile Chain Box in Rear
TOOLBOX HANDLE	Chrome T Handle Compression	Chrome T Handle Compression
FENDERS	Steel Radius	Steel Radius
SIDESTEPS	Integrated Front to Rear	Integrated Front to Rear
TIE DOWNS	18" Airline Track Tiedowns, (4) Attachment Rings	18" Airline Track Tiedowns, (4) Attachment Rings

FEATURES AND OPTIONS



NOTABLE OPTIONS INCLUDE: 3/16" Heavy-Duty Deck; 30K B&W Hitch with Turnover Ball (required for 5th Wheel capability); Bale Spikes; Color Primer Only; Stainless Fenders; Work Lights (standard on TM Deluxe)



ALRS

ALUMINUM

Light on price, heavy on performance: The all-aluminum ALRS truck bed delivers maximized fuel economy, payload and corrosion resistance at an incredible value.

FEATURES AND OPTIONS

LENGTHS	84", 8'6", 9'4"
HEADACHE RACK	Aluminum Tube
HEADACHE RACK LIGHTING	Clear LED Oval
DECK	Extruded Aluminum Floor
FRAME RAILS	4" Aluminum Channel
CROSSMEMBERS	3" Extruded Aluminum
REAR SKIRT	14" Solid One Piece Square Back

SIDE RAILS	3/8 x 2" Aluminum Extrusion with Aluminum Stake Pockets
FUEL FILL	Angled (Cast Aluminum)
REAR LIGHTING	Clear LED Oval
LIGHT BOX (REAR SKIRT)	Aluminum
MARKER LIGHTING	Bullet DOT Approved LED
TOOLBOX	Optional Underbody

NOTABLE OPTIONS INCLUDE: Cargo Light; Underbody Toolbox; Wood, Rubber or Blackwood Flooring



STEEL AND ALUMINUM TRUCK BEDS



WD

Specially designed for a welder's needs, the WD truck bed comes with a smooth deck, no gooseneck hitch and no headache rack, and a recessed welding machine platform.

LENGTHS	84", 8'6", 9'4", 11'4"
HEADACHE RACK	Optional
HEADACHE RACK LIGHTING	None
DECK	1/8" Smooth Steel
FRAME RAILS	4" Structural Channel Steel
CROSSMEMBERS	3" x 3/16" Channel
REAR SKIRT	Solid One Piece with Tapered Corners
GN HITCH	Optional
BP HITCH	18,500 lb. B&W Hitch with Receiver Tube
SIDE RAILS	N/A

FUEL FILL	Angled
12V TRAILER PLUG	Round 7 Pin in GN Box, Round 7 Pin/4 Way Flat on Rear
REAR LIGHTING	Clear LED Oval
LIGHT BOX (REAR SKIRT)	Steel
MARKER LIGHTING	Bullet DOT Approved LED
TOOLBOX	(4) Standard Integrated
TOOLBOX HANDLE	Chrome T Handle Compression
FENDERS	Steel Radius
SIDESTEPS	In front of and behind fender
TIE DOWNS	N/A

FEATURES AND OPTIONS

NOTABLE OPTIONS INCLUDE: 3/16" Heavy-Duty Deck; Color Primer Only; Deck on Front



DB

With its sleek design, ultra-durable hardware and unsurpassed features, including a heavy-duty two-way rear gate, this rugged dump hauling body is the smart choice for professionals in construction, excavation, landscaping and beyond.

FEATURES AND OPTIONS

LENGTHS	9', 11', 14', 16', 20'
HEADACHE RACK	Formed Steel with Cab Protector
DECK	10-Gauge
FRAME RAILS	6" Channel Steel
CROSSMEMBERS	3" Structural

FUEL FILL	Chassis OEM
12V TRAILER PLUG	Completed at Upfit
REAR LIGHTING	Chassis OEM
MARKER LIGHTING	Red
TIE DOWNS	(4) Welded with D-Rings

NOTABLE OPTIONS INCLUDE: Fold Down Sides, Tarp, 4' Tall sides



STEEL AND ALUMINUM TRUCK BEDS



Unique and versatile by design, the GP model thrives on the oilfield; its Cin Pole lifting system makes quick work of loading and unloading equipment.

GP

LENGTHS	8'6", 9'4", 11'4"
HEADACHE RACK	Steel Pipe
HEADACHE RACK LIGHTING	Clear LED Oval
DECK	3/16" Treadplate
FRAME RAILS	6" Structural Channel Steel
CROSSMEMBERS	3" x 3/16" Channel
REAR SKIRT	Solid One Piece Square Tailboard with Rolling Section & 5" Rolling Tailboard
GN HITCH	30K B&W Hitch with Welded Ball
BP HITCH	18,500 lb. Hitch with Receiver Tube
SIDE RAILS	Integrated Side Rails with Internal Stake Pockets

FUEL FILL	Angled
12V TRAILER PLUG	Round 7 Pin in GN Box, Round 7 Pin/4 Way Flat on Rear
REAR LIGHTING	LED Oval
LIGHT BOX (REAR SKIRT)	Steel
MARKER LIGHTING	Bullet DOT Approved LED
TOOLBOX	Two in Front
TOOLBOX HANDLE	T Handle Compression
FENDERS	N/A
PAINT FINISH	Premium Polyurethane
POLES	Schedule 80 Gin Poles with Frame and Pipe Holders

FEATURES AND OPTIONS

NOTABLE OPTIONS INCLUDE: Junk Basket; Water Cooler Rack; Winch Package (12K or 15K)



SZ

Load and unload hay from the comfort of your cab with the SZ's best-in-class dual hydraulic lifting cylinders and 4-directional remote control, plus dual round bale capacity.

FEATURES AND OPTIONS

LENGTHS	8'6", 9'4", 11'4"
HEADACHE RACK	Steel Tube
HEADACHE RACK LIGHTING	Clear LED Oval
DECK	1/8" Treadplate
FRAME RAILS	4" Structural Channel Steel
CROSSMEMBERS	3" x 3/16" Channel
REAR SKIRT	Solid One Piece with Rear Step
GN HITCH	30K B&W Hitch with Welded Ball
BP HITCH	18,500 lb. B&W Hitch with Receiver Tube
SIDE RAILS	Tube

FUEL FILL	Angled
12V TRAILER PLUG	Round 7 Pin in GN Box, Round 7 Pin/4 Way Flat on Rear
REAR LIGHTING	Clear LED Oval
LIGHT BOX (REAR SKIRT)	Steel
MARKER LIGHTING	Bullet DOT Approved LED
TOOLBOX	Two Standard Toolboxes
TOOLBOX HANDLE	Chrome T Handle Compression
FENDERS	N/A
SIDESTEPS	N/A
TIE DOWNS	(4) 18" Airline Track Tiedowns, (4) Attachment Rings

NOTABLE OPTIONS INCLUDE: 3/16" Heavy-Duty Deck; 30K B&W Hitch with Turnover Ball (required for 5th Wheel capability); Cargo Light



STEEL AND ALUMINUM TRUCK BEDS



BL

Heavy-duty integrated bale spikes transport huge loads securely, while top-quality steel construction ensures lasting durability. The BL (Bale Spike) is available as an option on any steel CM Truck Beds model.

LENGTHS	8'6", 9'4", 11'4"
HEADACHE RACK	Steel Tube
HEADACHE RACK LIGHTING	Clear LED Oval
DECK	1/8" Treadplate
FRAME RAILS	4" Structural Channel Steel
CROSSMEMBERS	3"x 3/16" Channel
REAR SKIRT	Solid One Piece with Rear Step
GN HITCH	30K B&W Hitch with Welded Ball
BP HITCH	18,500 lb. B&W Hitch with Receiver Tube
SIDE RAILS	Tube

FUEL FILL	Angled
12V TRAILER PLUG	Round 7 Pin in GN Box, Round 7 Pin/4 Way Flat on Rear
REAR LIGHTING	Clear LED Oval
LIGHT BOX (REAR SKIRT)	Steel
MARKER LIGHTING	Bullet DOT Approved LED
TOOLBOX	One Standard in Front on R/S
TOOLBOX HANDLE	Chrome T Handle Compression
FENDERS	Steel Radius
SIDESTEPS	N/A
TIE DOWNS	(4) 18" Airline Track Tiedowns, (4) Attachment Rings

FEATURES AND OPTIONS

NOTABLE OPTIONS INCLUDE: 3/16" Heavy-Duty Deck; 30K B&W Hitch with Turnover Ball (required for 5th Wheel capability); Cargo Light; Drop-In Side Rails

STEEL

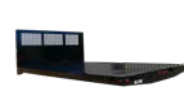

MODEL	SS	RD	SK	ER	TM	TM DELUXE	TMX	PL	PLS
LENGTHS	84", 8'6", 9'4", 11'4"	84", 8'6", 9'4", 11'4"	84", 8'6", 9'4", 11'4"	84", 8'6", 9'4", 11'4"	84", 8'6", 9'4", 11'4"	84", 8'6", 9'4", 11'4"	84", 8'6", 9'4", 11'4"	10'-18" = Standard Duty, 20'-24" = Heavy Duty	10'-18'
HEADACHE RACK	Steel Tube	Steel Tube	Steel Tube	Steel Tube	Steel Tube	Steel Tube	Steel Tube	Formed Bulkhead with Punched Grill	Bolt-On Headache Rack and Ship-Through Corners
HEADACHE RACK LIGHTING	Clear LED Oval	Clear LED Oval	Clear LED Oval	Clear LED Oval w/ chrome housing	Clear LED Oval	Clear LED Oval	Clear LED Oval	N/A	N/A
DECK	1/8" Treadplate	1/8" Treadplate	1/8" Treadplate	1/8" Treadplate	1/8" Treadplate	1/8" Treadplate	1/8" Treadplate	10'-18" = 1/8" Treadplate, 20'-24" = 3/16" Treadplate	1/8" Treadplate
FRAME RAILS	4" Structural Channel Steel	4" Structural Channel Steel	4" Structural Channel Steel	4" Structural Channel Steel	4" Structural Channel Steel	4" Structural Channel Steel	4" Structural Channel Steel	10'-18" = 4" Structural Channel Steel, 20'-24" = 8" Channel	4" Structural Channel Steel
CROSSMEMBERS	3" x 3/16" Channel	3" x 3/16" Channel	3" x 3/16" Channel	3" x 3/16" Channel	3" x 3/16" Channel	3" x 3/16" Channel	3" x 3/16" Channel	10'-18" = 3" x 3/16" Channel, 20'-24" = 4" Channel	3" x 3/16" Channel
REAR SKIRT	Solid One Piece with Tapered Corners	Solid One Piece with Tapered Corners	Solid One Piece with Tapered Corners and Rear Step	Solid One Piece with Tapered Corners and Rear Step	Solid One Piece with Tapered Corners and Rear Step	Solid One Piece with Tapered Corners and Rear Step	Solid One Piece with Tapered Corners and Rear Step	N/A	N/A
GN HITCH	30K B&W Hitch w/ Welded Ball in Recessed Box	30K B&W Hitch w/ Welded Ball in Recessed Box	30K B&W Hitch w/ Welded Ball in Recessed Box	30K B&W Hitch with Welded Ball in Trough	30K B&W Hitch w/ Welded Ball in Recessed Box	30K B&W Hitch w/ Welded Ball in Recessed Box	30K B&W Hitch w/ Welded Ball in Recessed Box	N/A	N/A
BP HITCH	18,500 lb. B&W Hitch with Receiver Tube	18,500 lb. B&W Hitch with Receiver Tube	18,500 lb. B&W Hitch with Receiver Tube	18,500 lb. B&W Hitch with Receiver Tube	18,500 lb. B&W Hitch with Receiver Tube	18,500 lb. B&W Hitch with Receiver Tube	18,500 lb. B&W Hitch with Receiver Tube	ICC optional	ICC Optional
SIDE RAILS	Integrated Side Rails with Internal Stake Pockets	3/8" x 2" Side Rails with Stake Pockets	3/8" x 2" Side Rails with Stake Pockets	Raised Side Rail with Aluminum Cap	N/A	N/A	N/A	3/8" x 2" Side Rails with Stake Pockets	Smooth Side Rails with Internal Stake Pockets
FUEL FILL	Angled	Angled	Angled	Angled (Cast Aluminum)	Angled	Angled	Angled	N/A	N/A
12V TRAILER PLUG	Round 7 Pin in GN Box, Round 7 Pin/4 Way Flat on Rear	Round 7 Pin in GN Box, Round 7 Pin/4 Way Flat on Rear	Round 7 Pin in GN Box, Round 7 Pin/4 Way Flat on Rear	Round 7 Pin in GN Box, Round 7 Pin/4 Way Flat on Rear	Round 7 Pin in GN Box, Round 7 Pin/4 Way Flat on Rear	Round 7 Pin in GN Box, Round 7 Pin/4 Way Flat on Rear	Round 7 Pin GN Box, Round 7 Pin/4 Way Flat on Rear	N/A	N/A
REAR LIGHTING	Clear LED Oval	Clear LED Oval	Clear LED Oval	Clear LED Oval w/ chrome housing	Clear LED Oval	Clear LED Oval	Clear LED Oval	N/A	N/A
LIGHT BOX (REAR SKIRT)	Steel	Steel	Steel	Cast Aluminum	Steel	Steel	Steel	N/A	N/A
MARKER LIGHTING	Bullet DOT Approved Clear LED	Bullet DOT Approved Clear LED	Bullet DOT Approved Clear LED	Bullet DOT Approved Clear LED	Bullet DOT Approved Clear LED	Bullet DOT Approved Clear LED	Bullet DOT Approved Clear LED	Bullet DOT Approved Clear LED	Bullet DOT Approved Clear LED
TOOLBOX	Optional Underbody	Optional Underbody	(4) Standard Integrated	(4) Standard Integrated	Utility Box in Front, Top-Open 3/4 Length Shovel Box; Low-Profile Chain Box in rear	Utility Box in front; Top-Open 1/2 Length Shovel Box; Tall Chain Box in rear; Opossum Belly	Utility Box in front; Top-Open 3/4 Length Shovel Box; Low-Profile Chain Box in rear	Optional Underbody	Optional Underbody
TOOLBOX HANDLE	N/A	N/A	Chrome T Handle Compression	Chrome T Handle Compression	Chrome T Handle Compression	Chrome T Handle Compression	Chrome T Handle Compression	N/A	N/A
FENDERS	N/A	N/A	Steel Radius	Chrome Radius	Steel Radius	Steel Radius	Steel Radius	N/A	N/A
SIDE STEPS	N/A	N/A	Integrated Front to Rear	Integrated Front to Rear	Integrated Front to Rear	Integrated Front to Rear	Integrated Front to Rear	N/A	N/A
TIE DOWNS	N/A	N/A	N/A	(4) 18" Airline Track Tiedowns (4) Attachment Rings	(4) 18" Airline Track Tiedowns (4) Attachment Rings	(4) 24" Airline Track Tiedowns (4) Attachment Rings	(4) 24" Airline Track Tiedowns, (4) Attachment Rings	N/A	N/A
ADDITIONAL FEATURES	Drop-in Side Rails Optional	Drop-in Side Rails Optional	Drop-in Side Rails Optional	Trough in Center for Convenient Hookup	Rear Tailgate with Paddle Latch	Rear Tailgate with Paddle Latch	Rear Tailgate with Paddle Latch	Optional HD Package Optional ICC Bumper	Optional ICC Bumper

ALUMINUM

 WD	 DB	 GP	 SZ	 BL	 AL ER	 AL PL ALL ALUMINUM	 AL RD	 AL RS ALL ALUMINUM	 AL SK
84", 8'6", 9'4", 11'4"	9', 11', 14', 16', 20'	84", 8'6", 9'4", 11'4"	8'6", 9'4", 11'4"	8'6", 9'4", 11'4"	84", 8'6", 9'4", 11'4"	10'-18" = Standard Duty	84", 8'6", 9'4", 11'4"	84", 8'6", 9'4"	84", 8'6", 9'4", 11'4"
Optional	Formed Steel	Steel Pipe	Steel Tube	Steel Tube	Aluminum Tube	Aluminum Tube	Aluminum Tube	Aluminum Tube	Aluminum Tube
None	N/A	Clear LED Oval	Clear LED Oval	Clear LED Oval	Clear LED Oval w/ Chrome Housing	N/A	Clear LED Oval	Clear LED Oval	Clear LED Oval
1/8" Smooth Steel	10-Gauge	3/16" Treadplate	1/8" Treadplate	1/8" Treadplate	1/8" Aluminum Treadplate	Extruded Aluminum Floor	Extruded Aluminum Floor	Extruded Aluminum Floor	Extruded Aluminum Floor
4" Structural Channel Steel	6" Structural Channel Steel	6" Structural Steel	4" Structural Channel Steel	4" Structural Channel Steel	4" Structural Channel Steel	4" Aluminum Channel	4" Structural Channel Steel	4" Aluminum Channel	4" Structural Channel Steel
3"x 3/16" Channel	6" Structural Channel	3"x 3/16" Channel	3"x 3/16" Channel Crossmembers	3"x 3/16" Channel	3"x 3/16" Channel	3" Aluminum Channel	3"x 3/16" Channel	3" Extruded Aluminum Crossmembers	3"x 3/16" Channel Crossmembers
Solid One Piece with Tapered Corners	N/A	Solid One Piece with Straight Corners at Rear & 5" Rolling Tailboard	Solid One Piece with Rear Step	Solid One Piece with Rear Step	Solid One Piece with Rear Step	One Piece Aluminum	Solid One Piece with Tapered Corners	14" Solid One Piece Square Back	Solid One Piece with Rear Step
Optional	N/A	25K in Recessed Box	30K B&W Hitch with Welded Ball	30K B&W Hitch with Welded Ball	30K B&W Hitch with Welded Ball in Trough	N/A	30K B&W Hitch with Welded Ball in Recessed Box	N/A	30K B&W Hitch with Welded Ball in Recessed Box
18,500 lb. B&W Hitch with Receiver Tube	N/A	18,500 lb. Hitch with Receiver Tube	18,500 lb. B&W Hitch with Receiver Tube	18,500 lb. B&W Hitch with Receiver Tube	18,500 lb. B&W Hitch with Receiver Tube	ICC Optional	18,500 Lb. B&W Hitch with Receiver Tube	N/A	18,500 Lb. B&W Hitch with Receiver Tube
N/A	N/A	N/A	Tube	Tube	Raised Side Rail with Aluminum Cap	3/8" X 2" Side Rails with Stake Pockets	3/8" X 2" Side Rails with Stake Pockets	3/8" X 2" Side Rails with Stake Pockets	3/8" X 2" Side Rails with Stake Pockets
Angled	Chassis OEM	N/A	Angled	Angled	Angled (Cast Aluminum)	N/A	Angled (Cast Aluminum)	Angled (Cast Aluminum)	Angled (Cast Aluminum)
Round 7 Pin in GN Box, Round 7 Pin/4 Way Flat on Rear	Completed at Upfit	Round 7 Pin in GN Box, Round 7 Pin	Round 7 Pin GN Box, Round 7 Pin/4 way flat on rear	Round 7 Pin GN Box, Round 7 Pin/4 way flat on rear	Round 7 Pin in GN Box, Round 7 Pin/4 Way Flat on Rear	N/A	Round 7 Pin in GN Box, Round 7 Pin/4 Way Flat on Rear	N/A	Round 7 Pin in GN Box, Round 7 Pin/4 Way Flat on Rear
Clear LED Oval	Chassis OEM	LED Oval	Clear LED Oval	Clear LED Oval	Clear LED Oval w/Chrome Housing	N/A	Clear LED Oval	Clear LED Oval	Clear LED Oval
Steel	N/A	Steel	Steel	Steel	Cast Aluminum	N/A	Aluminum	Aluminum	Aluminum
Bullet DOT Approved Clear LED	2" Red	Bullet DOT Approved LED	Bullet DOT Approved Clear LED	Bullet DOT Approved Clear LED	Bullet DOT Approved Clear LED	Bullet DOT Approved Clear LED	Bullet DOT Approved Clear LED	Bullet DOT Approved Clear LED	Bullet DOT Approved Clear LED
(4) Standard Integrated	N/A	(2) Standard in Front of Fenders	(2) Standard	(1) Standard in Front on R/S	(4) Standard Integrated	Optional Underbody	Optional Underbody	Optional Underbody	(4) Standard Integrated
Black T Handle Compression	N/A	N/A	Black T Handle Compression	Black T Handle Compression	Black T Handle Compression	N/A	N/A	N/A	Black T Handle Compression
Steel Radius	N/A	N/A	N/A	Steel Radius	Chrome Radius	N/A	N/A	N/A	Aluminum Radius
1.66" Pipe Perimeter Bottom Steps	N/A	N/A	N/A	N/A	Aluminum Steps Integrated Front to Rear	N/A	N/A	N/A	Aluminum Steps Integrated Front to Rear
N/A	(4) Welded in D-Rings	N/A	4) 18" Airline Track Tiedowns, (4) Attachment Rings	(4) 18" Airline Track Tiedowns, (4) Attachment Rings	(4) 18" Airline Track Tiedowns (4) Attachment Rings	N/A	N/A	N/A	N/A
Rear Angle V Groove Across Back 3" Drop Deck on Front	Bolt-on Hoist Subframe and Install Kit Rigid or Fold-Down Sides	(2) Schedule 80 Gin Poles with Troughs on Both Sides, Optional Rolling Tailboard on Rear			Trough In Center For Convenient Hookup	Optional ICC Bumper, Aluminum Stake Sides	Drop-In Aluminum Side Rails (Optional)	Drop-In Aluminum Side Rails (Optional)	Drop-In Aluminum Side Rails (Optional)

VERSATILITY FOR EVERY BODY

CM TRUCK BEDS SERVICE BODIES ARE THE MOST VERSATILE ON THE MARKET TODAY. WHATEVER THE APPLICATION, CM HAS THE RIGHT SERVICE BODY AVAILABLE AND READY TO BE DELIVERED FASTER THAN ANY BODY. COMPONENT-STYLE CONFIGURATIONS ALLOW FOR EASY CUSTOMIZATION, AND THE BEST WARRANTY IN THE INDUSTRY ENSURES YEARS OF RELIABLE USE.

COMPONENT-STYLE CONFIGURATION

Go ahead, put our products through the wringer. Unlike many in the industry, our component bodies are bolted together, which makes repair and maintenance far easier. Need a different configuration? Customization is as simple as unbolting the part you want to change.



DURABLE POWDERCOAT FINISH

While other companies stick to paint, CM Truck Beds coats every Service Body we make with powder. Using the highest quality powder-coat finish, we go under every edge and cover every crevice to ensure your service body is protected. This superior finish also adds a shine that will last for many years.



GAS CYLINDER DOOR SHOCKS

We don't use simple springs, we use the finest gas shocks on the market today. Even when your hands are full, our gas shocks allow you to easily open and close our doors.



HEAVY-DUTY REAR TAILGATES

All Service Bodies from CM Truck Beds feature tailgates that are tough enough to keep materials inside the deck where they belong. Need to step to get in a bed? No problem: These tailgates are rated at over 400 pounds, supporting even the largest operators to gain access.



DECKS

Our best-in-class steel decks provide a solid foundation for ensuring our bodies will live up to the rigorous expectations of our customers. We not only start with a strong deck, but also coat it with our super-durable Black Lava deck coating, which enhances the overall performance of our Service Bodies.



AUTOMOTIVE STAINLESS-STEEL ROTARY LATCHES & D-BULB WEATHER-STRIPPING

Toolboxes carry a worker's best friend: his tools. To protect them, our toolbox doors feature heavy-duty rotary latches, and are sealed with D-bulb weather-stripping to ensure that no moisture gains entry. So your tools are not only safe, but also safely out of the elements.



LED REAR LIGHTING WITH WIRING HARNESS

When safety counts, count on CM Truck Beds to take care of you. We utilize the safest, easiest-to-maintain lights available. LED lights are brighter, light up instantaneously, and make for easier maintenance.

4-YEAR / 48,000-MILE WARRANTY

Some companies say they stand behind their products; we put it in writing. While the industry standard is to only warranty a body for a period of 36 months, we're happy to go above and beyond and offer a 48-month warranty. We recognize what an investment a Service Body can be and we want you to know that we're with you for the long haul.



SB STEEL SERVICE BODY

CM Truck Beds' SB model is America's ultimate utility hauling Service Body. Often copied, the SB is unparalleled in quality, with long-lasting hardware and remarkable durability.



Gain added peace of mind from CM Truck Beds' **4-Year / 48,000-mile Warranty and 6-Year No Rust Guarantee** on all Steel Service Bodies



NOTABLE FEATURES INCLUDE:
Bolt-on, drop-in flip-top compartments close securely with automotive stainless steel rotary latches; rear LED lights provide bright, instantaneous light and easy maintenance; toolbox interiors are powdercoated to prevent rust and corrosion

STANDARD FEATURES

- 11-Gauge Galvaneal Deck
- 16-Gauge Galvaneal Body (A60)
- Removable Fender Panel
- Stainless Steel Rod & Socket Door Hinges
- Gas Cylinder Style Door Holders
- LED Rear Lighting with Wiring Harness
- Recessed Rear Bumper
- 1/8" Treadbrite Aluminum Compartment Tops
- Automotive Stainless Steel Rotary Latches
- Vise Socket in Bumper
- Conduit in Understructure
- Bolted Body for Secure Attachment
- Automotive D-Bulb Weather Stripping
- Multi-Panel Doors with Internal Reinforcements
- Toolbox Interior Powdercoated
- Heavy-Duty Rear Tailgate
- Two Shelves in the Front, One Shelf in the Rear



- 100% primer & topcoat
- Super durable powdercoat provides coating for years of protection
- Zinc rich primer is used on all surfaces for unsurpassed corrosion protection
- Individually coated components for maximum coverage
- Black Lava non slip coating on deck, bumper and undercarriage for maximized protection and reduced slip hazard

SBA ALUMINUM SERVICE BODY

Enjoy all the utility of the popular SB model, with the added benefits of CM Truck Beds' heavy-duty, precision-engineered aluminum. The SBA is lighter weight for improved fuel economy, rust- and corrosion-resistant, and yet remarkably strong and long-lasting.



Gain added peace of mind from CM Truck Beds' **4-Year / 48,000-mile Warranty and 10-Year No Rust Guarantee** on all Aluminum Service Bodies

CM
TRUCK BEDS

SERVICE BODIES



STANDARD FEATURES

- .090 Aluminum Body
- .125 Smooth Aluminum Deck
- Removable Fender Panel
- Stainless Steel Rod & Socket Door Hinges
- Gas Cylinder Style Door Holders
- LED Rear Lighting with Wiring Harness
- Recessed Rear Bumper
- 1/8" Treadbrite Aluminum Compartment Tops
- Automotive Stainless Steel Rotary Latches
- Vise Socket in Bumper
- Conduit in Understructure
- Bolted Body for Secure Attachment
- Automotive D-Bulb Weather Stripping
- Multi-Panel Doors with Internal Reinforcements
- Toolbox Interior Powdercoated
- Heavy-Duty Rear Tailgate
- Two Shelves in the Front, One Shelf in the Rear

NOTABLE FEATURES INCLUDE:

(From top) Durable, .125 smooth aluminum deck; available rear bumper vise mount for added versatility; toolboxes with powdercoated interiors; secure, stainless-steel rotary latches to protect valuable tools; bright, safe and hassle-free LED lighting

SERVICE BODY CONFIGURATIONS

**■ DON'T ADJUST TO YOUR BODY.
MAKE YOUR BODY ADJUST TO YOU.**

With an array of sizes and configurations to choose from, there's a CM Truck Beds Service Body designed to meet the specific needs of your industry and your fleet.

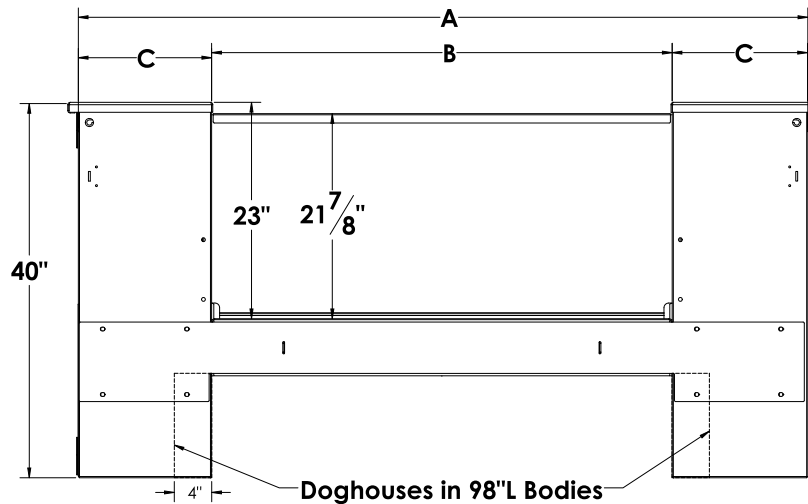

Chassis Style	C.A.	A	B	C
98SW	56"	78"	49"	14 ½"
98DW	56"	94"	49"	22 ½"
110SW	60"	78"	49"	14 ½"
110DW	60"	94"	49"	22 ½"
132DW	84"	94"	49"	22 ½"

SW - Single Wheel | DW - Dual Wheel

Cargo area wheel well boxes may be necessary to accommodate some chassis.

BODIES AVAILABLE IN ANY SIDEPACK COMBINATION

- "W" - Streetside & Curbside : "V" configuration
- "HH" - Streetside & Curbside : "H" configuration
- "VH" - Streetside : "V" configuration; Curbside : "H" configuration
- "HV" - Streetside : "H" configuration; Curbside : "V" configuration

OPTIONAL FLIP TOPS ARE AVAILABLE ON EITHER OR BOTH SIDES.

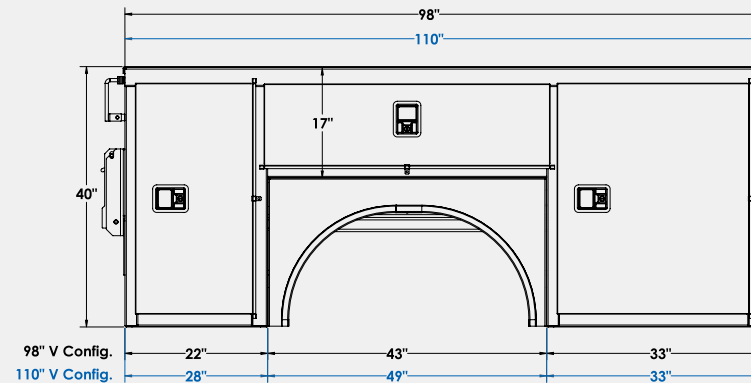

V CONFIGURATION (V98 & V110)

- 1st Vertical: Two adjustable shelves with two adjustable dividers per shelf
- Horizontal: Open with "Pass-Through" to rear vertical
- Rear Vertical: One adjustable shelf with two adjustable dividers

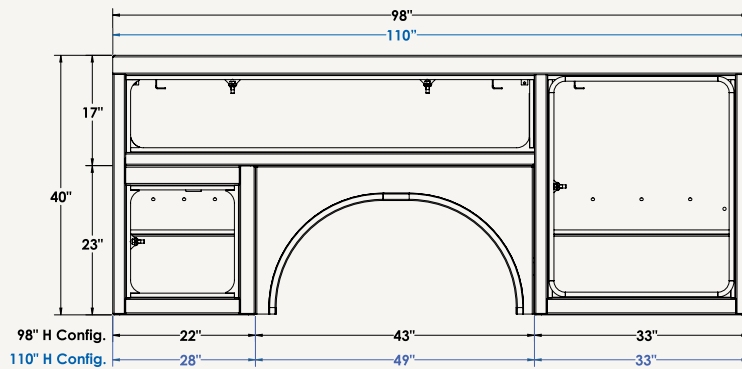

H CONFIGURATION (H98 & H110)

- 1st Vertical: Two adjustable shelves with two adjustable dividers per shelf
- Horizontal: One removable shelf with four adjustable dividers
- Rear Vertical: Open

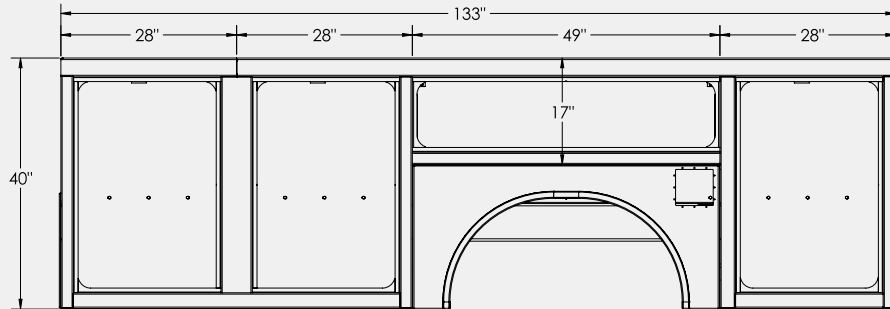

133" Body - Streetside V-Style Shown

V CONFIGURATION (V133)

- 1st Vertical: Two adjustable shelves with two adjustable dividers per shelf
- 2nd Vertical: Two adjustable shelves with two adjustable dividers per shelf
- Horizontal: Open with "Pass-Through" to rear vertical
- Rear Vertical: One adjustable shelf with two adjustable dividers

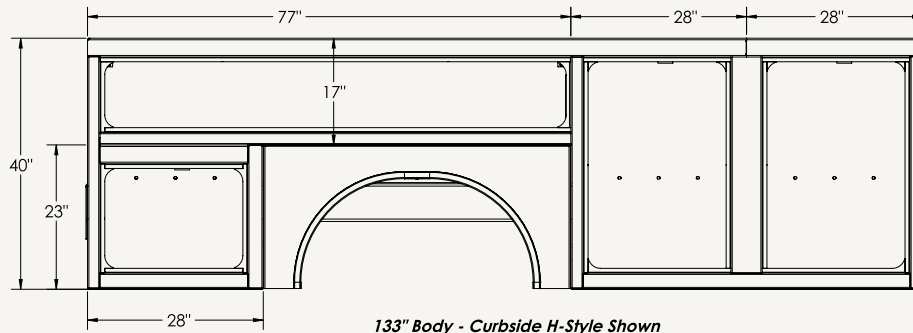

133" Body - Curbside H-Style Shown

H CONFIGURATION (H133)

- 1st Vertical: Two adjustable shelves with two adjustable dividers per shelf
- 2nd Vertical: Two adjustable shelves with two adjustable dividers per shelf
- Horizontal: One removable shelf with four adjustable dividers
- Rear Vertical: Open

CM

TRUCK BEDS®



BUILT FOR YOUR SUCCESS. Since 1990, CM Truck Beds has offered a wide range of feature-rich, work-ready products built to withstand the test of time and deliver the ultimate in value. Headquartered in Kingston, Oklahoma, CM Truck Beds has over 150,000 square feet of manufacturing and employs more than 300 experienced laborers and sales associates. We're proud to be the leader in flat-bed truck bodies, and we're dedicated to providing the solutions you need to get the job done.

When searching for a dependable and good-looking truck body that will help on the job site, down the road, or on the ranch, look no further than CM Truck Beds. Our field-tested products fit not only the vehicles they connect with but also the customers who use them, day in and day out. We utilize category-leading hitches, toolbox latches, and headache racks in addition to offering the toughest steel and aluminum beds and service bodies on the market.

Additionally, our strong network includes more than 200 distributors across North America who specialize in aftermarket upfit and installation. Count on superior product quality, large on hand inventory, and attention to detail throughout the upfitting process. It's this dedication to providing real-world solutions that makes CM Truck Beds the go-to source for hardworking professionals.



833-CMTRUCK | CMTRUCKBEDS.COM