

Osaki

Instruction Manual

OS-Duke XL

Osaki

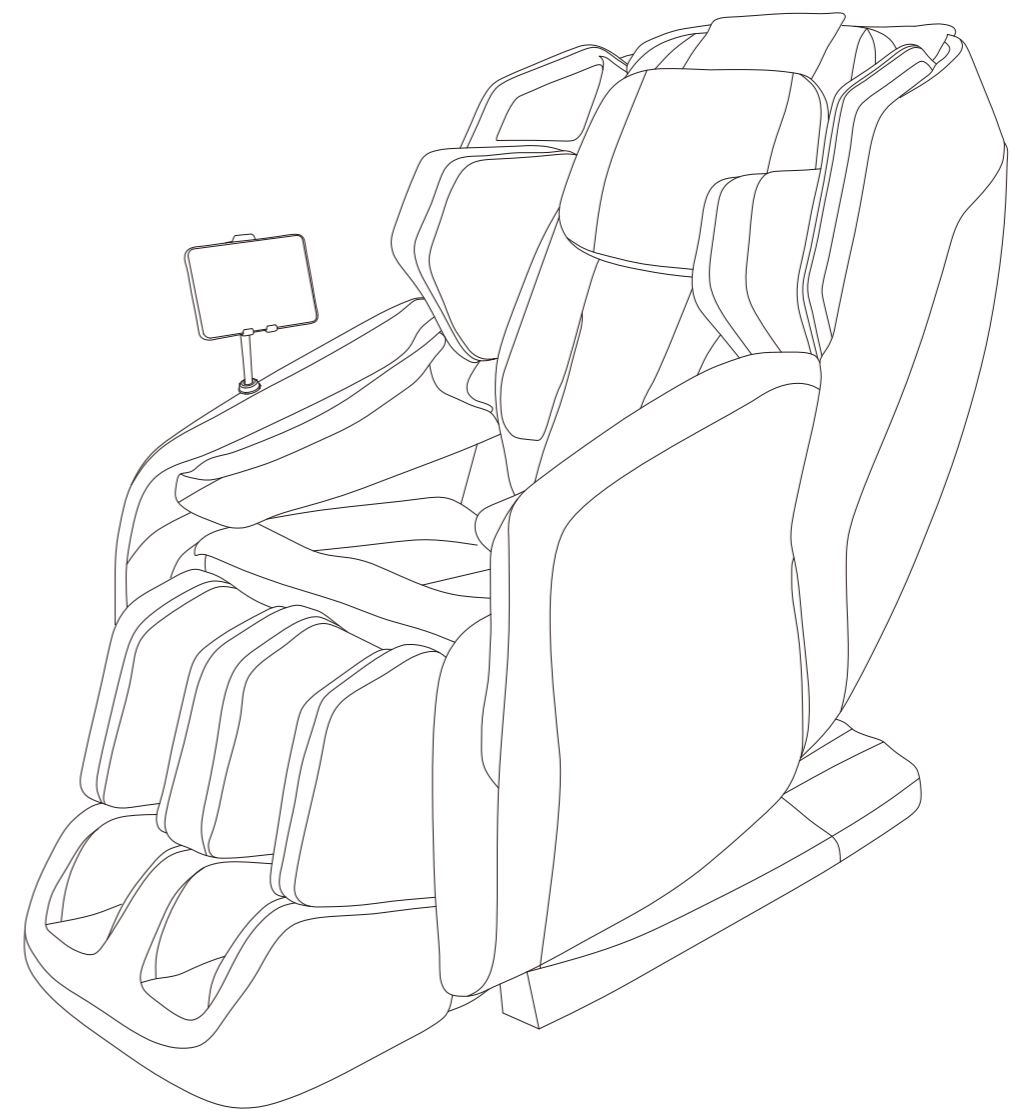

Please read SAFETY INSTRUCTIONS carefully before using the chair.



- ★ 1.Thank you for buying our massage chair
 - 2.Please read the user manual carefully to understand the operation way before operating the chair.
 - 3.Keep the user manual in a good condition for review if needed.
 - 4.Please pay special attention to “safety precautions” section.
- ★ Note: We reserve the rights of design change and explanation on the products, subject to change without prior notice, the pictures in the manual are for reference only, subject to real products.

Contents





Preparation	Safety precautions -----	1
	External structure name -----	5
	Internal structure name -----	6
	Mechanical components diagram -----	7
	Mechanical components list -----	8
Installation	Installation -----	9
Massage Operation	The adjustment before massage -----	14
	Built-in remote instructions -----	16
	Tablet remote control operation -----	18
	After Massage -----	26
Maintenance	Clean and maintenance -----	27
Others	Malfunction guide -----	28
	Technical data -----	29

Please store the user manual in a good place for reading at any time



- ★ ● Please read this manual carefully before use, and install and use it correctly according to the requirements of the manual.
 - ★ ● The safety precautions are to explain the size and severity of the hazard and damage. And divide some situations that may occur due to incorrect use and assumptions into two aspects: [Warning] and [Caution].
- Both are important safety warnings, please pay attention to them.

 Warning	This symbol is a warning that death or injury may occur.
 Caution	This symbol is a warning of possible injury or damage.

The Meaning of Symbols

	This symbol indicates prohibited behavior.		This symbol means that it is forbidden to disassemble by yourself.
	This symbol means that you must follow the instructions.		This symbol indicates the correct operation of the power cord..

- ★ ● After reading the following content, please be sure to keep it at any time.

 Warning	
	<ul style="list-style-type: none"> ● Patients with osteoporosis, spine fractures, and those suffering from acute painful diseases such as sprains or muscle strains. ● Heart disease patients (including those who are equipped with a pacemaker or are using other medical electronic equipment) Malignant tumor patients. ● People who suffer from perceptual impairment due to diabetes and other high-level peripheral circulatory disorders. ● People with abnormal spine or curved spine. ● People with herniated disc. ● Pregnant women and those who have just finished childbirth, and those who are in poor health. ● People suffering from trauma such as thrombosis, acute venous tumor, various skin inflammations, etc. ● People who have been found to have lost the ability to discern temperature. ● People with high fever symptoms (acute inflammation: such as fatigue, chills, changes in blood pressure, physical weakness) ● Seniors over 80 ● People who are mentally handicapped, mentally handicapped, or incapable of operating this machine are prohibited from using this machine. ● People who cannot take care of themselves, infants and drunk persons are prohibited from using this machine. ● It is forbidden to use this machine if it gets wet or people with wet body. ● People who are not sensitive to heat or those who are allergic to heat must be careful when using it, or do not use it. ● Do not fall asleep in this chair. <p>People with the above symptoms are prohibited from using this machine, or must consult a physician before using this machine. If this product is used, close supervision must be carried out.</p>
	For users not suitable, it may cause accidents or physical discomfort.

**Warning**

	<ul style="list-style-type: none"> ● Before sitting, please make sure that there are no foreign objects between the various parts of the machine. ● When using the backrest lift, lower leg lift, and lower leg extension, make sure that there are no people or objects around (behind, under, or in front of the chair). ● If you experience abnormalities or feel abnormalities during use, stop using it immediately and ask your doctor. ● When massaging around the head, pay attention to the movement of the massage head, and don't massage the head too much. ● When massaging the surrounding areas of the neck, be especially careful and avoid massaging the neck too heavily. ● Do not use this machine to massage your abdomen or knees. ● If you want to leave the seat during the massage, you must stop the operation of the massage chair before leaving the seat. ● Do not use it with other equipment at the same time. ● Do not let children or pets play on or around the machine (especially when in use); also do not sit or stand on the backrest, armrests, or legs. ● When used by people with limited mobility or lack of communication skills, strict and continuous care must be provided. ● Before moving the machine, the angle of the backrest and legs must be adjusted back to the original state. 	Accident or injury
	<ul style="list-style-type: none"> ● When installing this machine, please turn off the power switch and unplug the power plug after the chair is reset. ● Only connect the plug of this machine to a suitable power outlet. And be sure to fully insert the plug into the power socket to reduce the risk of short circuit or fire. ● When not in use, be sure to unplug the power plug of the machine. Before unplugging the power plug, turn off all massage actions and switches. 	Fire and electric shock
	<ul style="list-style-type: none"> ● It is forbidden to curl and store the cushions and other accessories of the massage chair. ● It is forbidden to run the machine without load for a long time. ● It is forbidden to leave the appliance unattended after plugging in the power source. 	Accident
	<ul style="list-style-type: none"> ● Do not use it when the power plug or socket is loosely inserted. To prevent electric shock and short circuit. ● Do not use a power supply other than the rated voltage to avoid fire, electric shock or malfunction. ● The power cord must not be broken, reworked, twisted, stretched, knotted, or pressed with heavy objects (pay special attention not to be pressed under the machine), etc. ● If the power cord or plug is damaged, cannot work normally, please do not use this product. ● Keep the power cord away from heat sources. 	Fire and electric shock
	<ul style="list-style-type: none"> ● If the machine is not working properly, has been dropped or damaged, has been splashed or dropped into the water, it must be repaired by professionals or sent to the designated repair center. Do not modify, disassemble and repair by yourself. ● If the power cord is damaged, you must use a special power cord or buy special components from its manufacturer or maintenance department to replace it. ● To avoid electric shock or personal injury, please do not open or disassemble any parts of this machine without authorization. There are no user-serviceable parts in this machine. ● Before use, please lift the back cushion to check whether the fabric of the backrest and other parts is damaged. If there is any damage (no matter how small the damage), please stop using it in time and unplug the power socket. Request for a repair. 	Disassembly and repair

**Caution**

	<ul style="list-style-type: none"> ● Please use it on a flat ground. 	To prevent it from accidental dumping.
	<ul style="list-style-type: none"> ● Please start with a light massage. The recommended use time is 20 minutes, and the same position massage within 5 minutes. 	Long time continuous use will have an adverse effect.
	<ul style="list-style-type: none"> ● Please confirm the correct position of the massage head before sitting down slowly. 	To avoid accidental damage.
	<ul style="list-style-type: none"> ● The tablet hand controller should be placed on the tablet support in time, and do not randomly place it to avoid damage to the tablet hand controller from being squeezed or dropped. 	
	<ul style="list-style-type: none"> ● Before connecting the power plug to the socket, be sure to check that the power switch is in the off position. 	Otherwise, it may cause an accident when the power is restored.
	<ul style="list-style-type: none"> ● When not in use, before unplugging the power plug, turn off all massage actions and switches. 	To reduce the risk of short circuit and fire.
	<ul style="list-style-type: none"> ● Check whether the power cord is damaged, there should be no adherents such as moisture or trash on the power plug. 	If you don't pay attention, you may get an electric shock in case of leakage or malfunction.
<ul style="list-style-type: none"> ● For safety, please install the ground wire accurately. The power plug must be plugged into a socket with a grounding wire. The ground plug cannot be bent or removed. 		
	<ul style="list-style-type: none"> ● Do not press or step on the massage head with hands and feet. ● Do not reach between the active massage heads. ● Do not put your hands and feet into the gaps of the movable mechanism. ● Please do not let objects fall or jam into any slots of the machine. ● Do not stand, sit or put anything on the backrest, armrests, or calves. ● Do not stand, sit or put anything on the backrest, armrests, or calves. ● Do not stand on the machine during use. ● Do not unplug the power plug and turn off the power switch during use. ● Do not put your hands and head into or under the calf massage area. ● Do not use hard hair accessories on the head. ● When massaging the buttocks and thighs, there should be no hard objects in the trouser pockets. ● Do not hit the armrest with hard objects or sharp cones, so as not to affect the appearance of the armrest. ● When the backrest of the massage chair is in an inclined position, do not sit on it or press it heavily. ● Do not use it when the skin is bare or wearing only thin clothes. Although thin clothes can enhance the massage effect, it may cause skin irritation and pain or low-temperature burns. ● Do not use this product immediately after meals, as it may cause physical discomfort. ● Do not use this machine while wearing loose clothes or jewelry. ● Keep long hair away from the massager. 	Keep long hair away from the massager.
	<ul style="list-style-type: none"> ● Keep this machine away from heat, humidity, sharp objects, and corrosive, flammable and explosive environments. ● It is forbidden to put heating items such as electric blankets on the machine. 	Otherwise, the fabric will fade, change color, or harden and deteriorate the synthetic leather.
<ul style="list-style-type: none"> ● Do not approach the stove or place it around heating appliances such as heaters. ● Do not place it under direct sunlight or in an environment where the room temperature is higher than 40°C. ● Do not place it in an environment with severe dust or corrosive gas. ● Do not place it in a small space or use in a place with poor air circulation. ● Do not use this unit outdoors. 		



Caution

	<ul style="list-style-type: none"> Please keep it dry and do not use or store this product in swimming pools, bathrooms and other particularly humid environments. The chair and the controller can not be sprinkled with water. Do not use this product when the body is wet. 	To prevent leakage or electric shock.
	<ul style="list-style-type: none"> Be sure to install the ground wire correctly. (Improper grounding connection may cause electric shock hazard. If you have any doubts about the correctness of the grounding of the machine, please entrust a qualified electrician for inspection.) Please do not use plug adapters. (If the plug attached to the machine does not match your socket, please do not modify the plug, but ask an electrician to install a suitable socket.) 	To reduce the risk of electric shock.
	<ul style="list-style-type: none"> Before cleaning the machine, be sure to unplug the power plug. After using this machine, be sure to unplug the power plug. In the event of a power failure, please unplug it immediately. Please pull out the power plug by holding the plug. Avoid pulling the power cord to unplug the power plug. 	To prevent fire or electric shock.
	<ul style="list-style-type: none"> After each massage, please turn off the power switch and unplug the power plug. 	To prevent accidents.
	<ul style="list-style-type: none"> Unplug the plug immediately when there is a power failure. 	Otherwise, it may cause an accident or injury when the power is restored.

Usage environment	Environment temperature: 0°C~35°C Relative humidity: 20%~80%
Storage environment	Environment temperature: -5°C~35°C Relative humidity: 20%~80%

★ Grounding Instructions

※This machine is equipped with a cable with a grounding plug. The plug must be plugged into a well-installed and grounded socket that meets the requirements of this plug.

★ Replace the Fuse

※When the fuse is blown, please unplug the power plug first, turn off the power switch, then use a screwdriver to open the fuse box cover on the switch box, replace with a new fuse of the same specification, and then reinstall the fuse box cover or entrust an electrician to assist in the replacement.

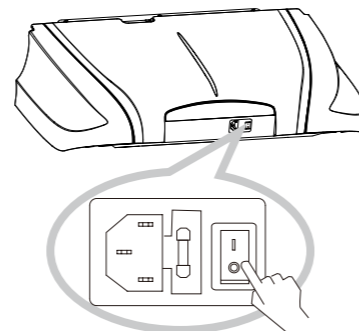

 The place where the ground wire cannot be set.	Gas pipe: may cause explosion and fire. Telephone lines and lightning rods: lightning may cause electric shock and fire. Water pipe: The ground wire does not work where there is plastic in the water pipe.
--	--

External Structure

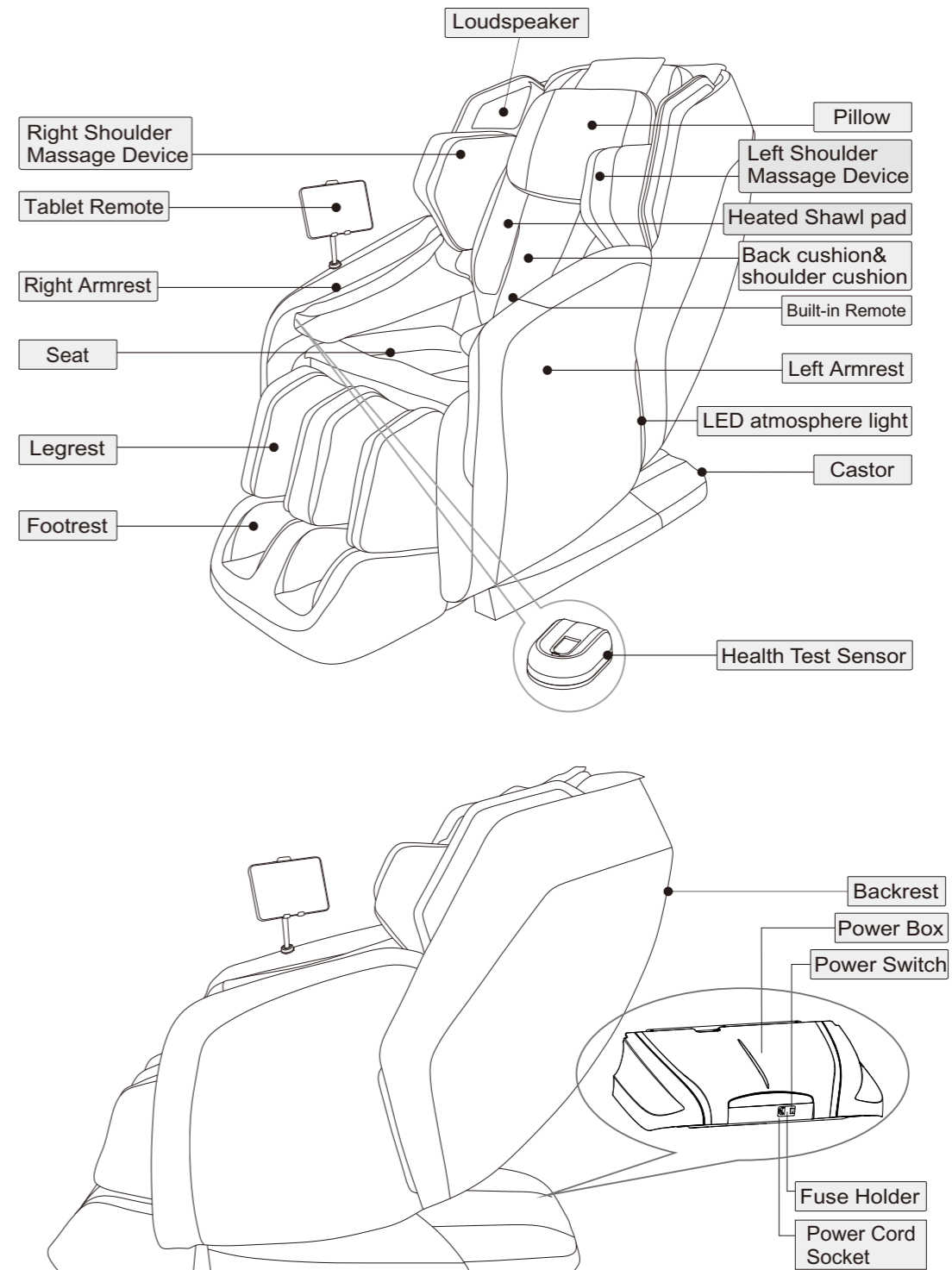

Preparation

Preparation

Internal Structure

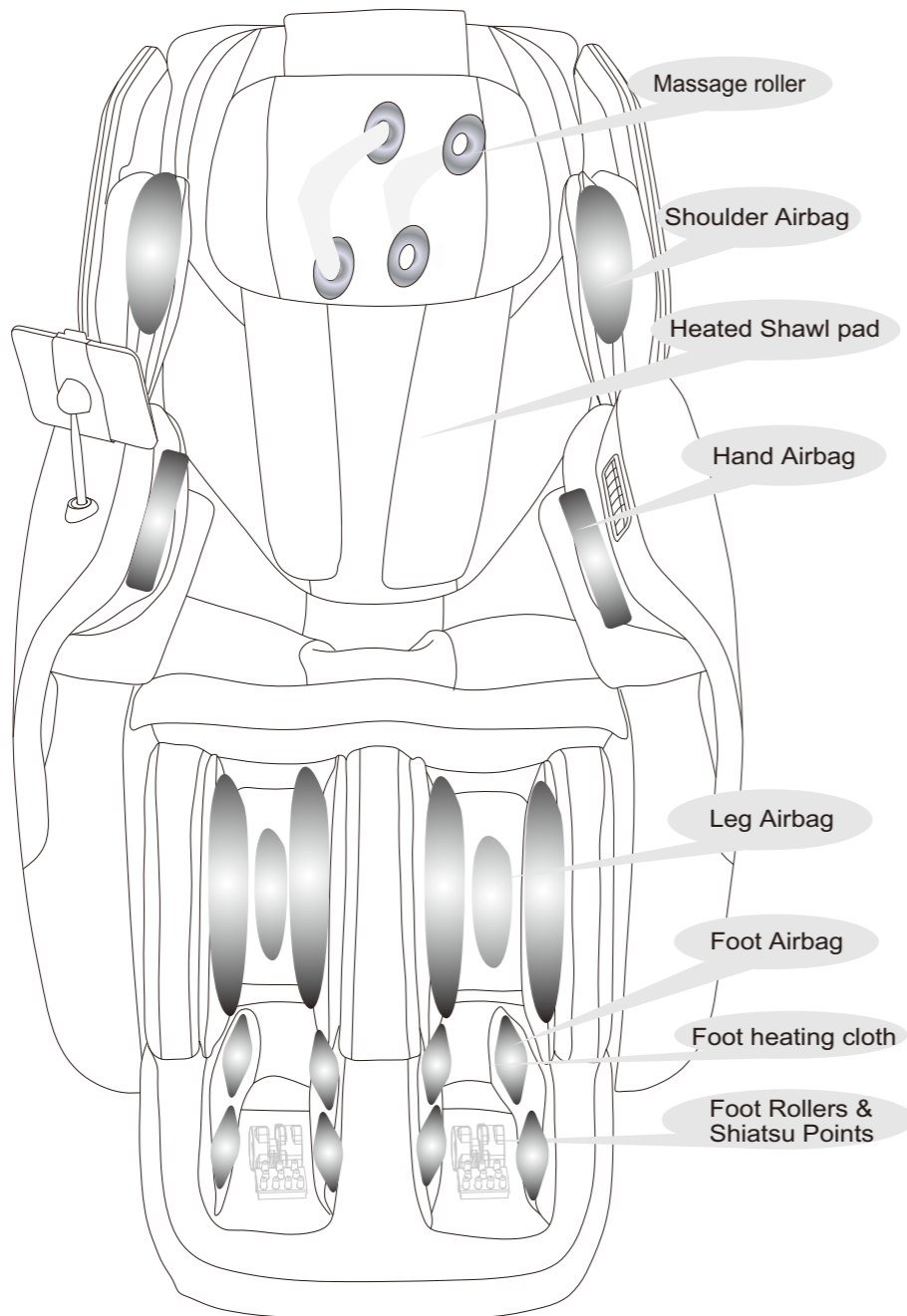

Preparation

Mechanical Explosive View

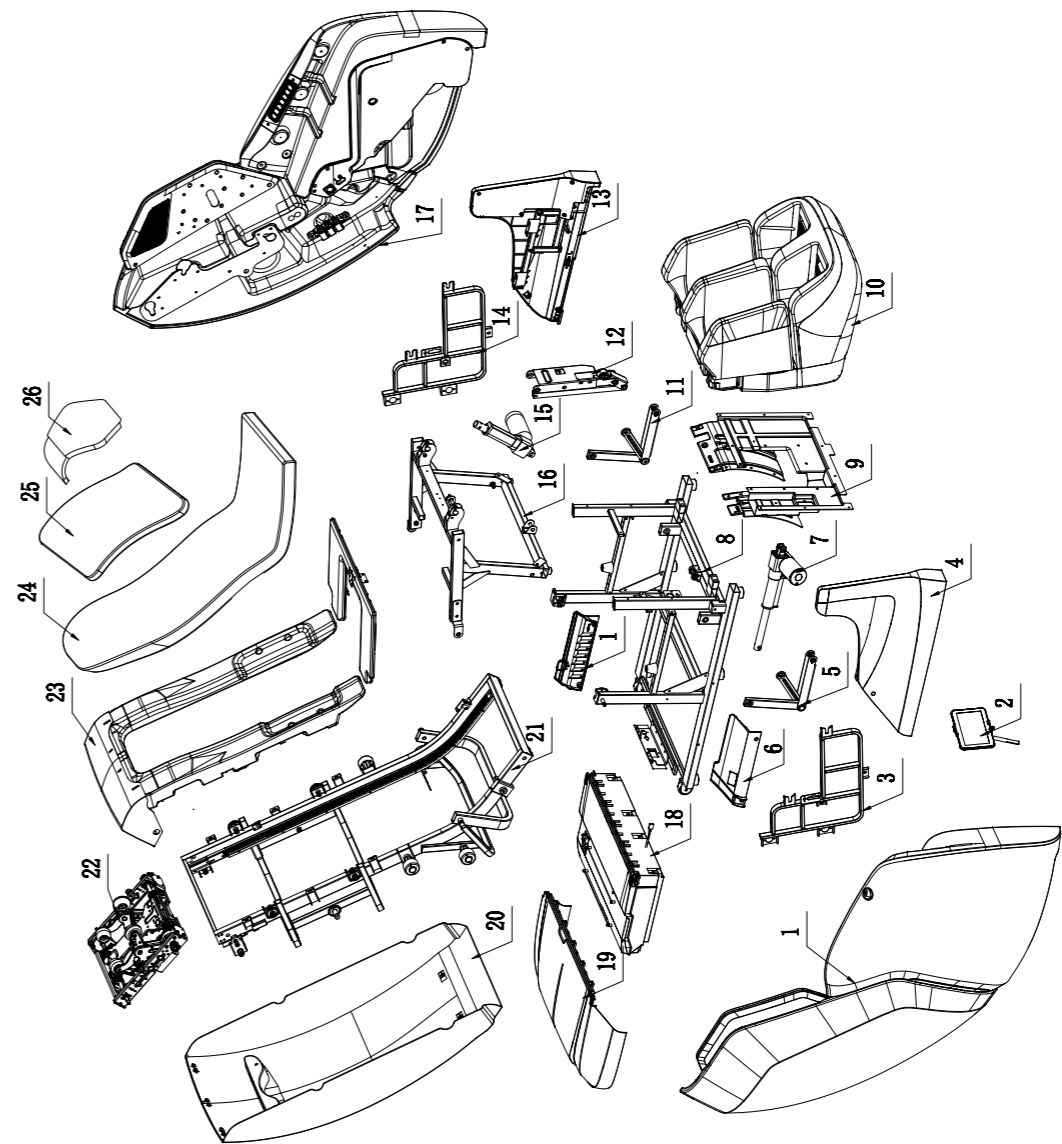

Preparation

Mechanical Components List

NO	NAME	PIECE	NO	NAME	PIECE
1	Right Arm & Shoulder Assembly	1	22	Massage Mech	1
2	CMC Tablet Controller	1	23	Front Cover Assembly	1
3	Armrest Conversion Rack Assembly (Right)	1	24	Back Seat Cushion	1
4	Right Fender	1	25	Shoulder Cushion	1
5	Rod Riveted Assembly (Right)	1	26	Pillow Assembly	1
6	Inner Fender (Right)	1			
7	Backrest Actuator	1			
8	Bottom Seat assembly	1			
9	Front Fender	1			
10	legrest Assembly	1			
11	Rod Riveted Assembly (Left)	1			
12	Leg &foot Connecting Plate Assembly	1			
13	Left Fender	1			
14	Left Armrest Transfer Frame	1			
15	Legrest Actuator	1			
16	Seat Frame Assembly	1			
17	Left Arm & Shoulder Assembly	1			
18	Power Box Assy	1			
19	Rear Cover Assembly	1			
20	Backrest Cover	1			
21	Backrest Frame Assembly	1			

Installation 1

- **Decide the setting place.**

- Please make sure you can tilt the space.

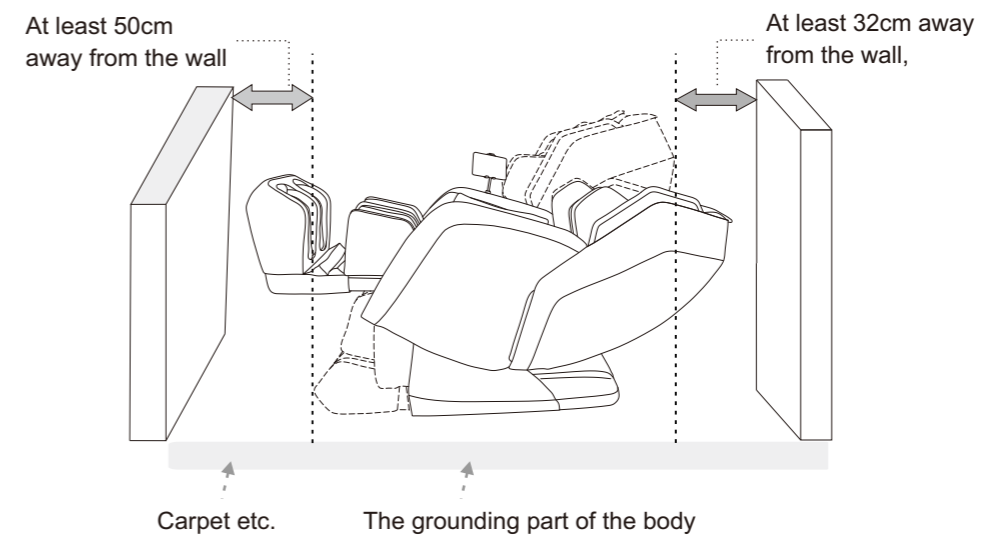
**Hint:**

because sometimes can damage the floor, so it is recommended to put carpet etc under the body, When laying, prepare a rug that can cover the ground part of the body.

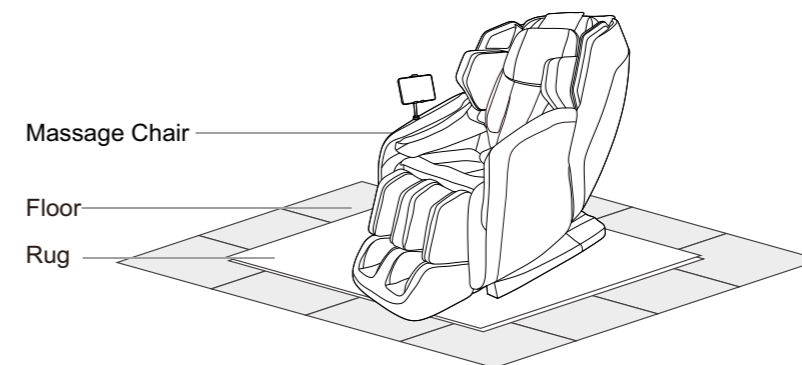
**Attention:**

- Do not use or store the product in swimming pool, bathroom or other particularly humid environment.
 - To prevent leakage, electric shock or failure.
- Please use on a flat field.
 - Prevent accidental dumping of the machine.
- Do not close to the stove or placed around the heating fan and other heating appliances.
 - Can cause fabric fading, discoloration or synthetic leather hardening deterioration, etc.

Installation 2

Step 1 Take the footrest, main body and accessory box out from the box.

- ① Hold the footrest from left and right two sides, take it away from the seat part.
- ② take out the accessories box and other parts, and lift out the body of the massage chair by more than two people.
- ③ Check and confirm whether the attachments are complete (please check one by one against the packing list)

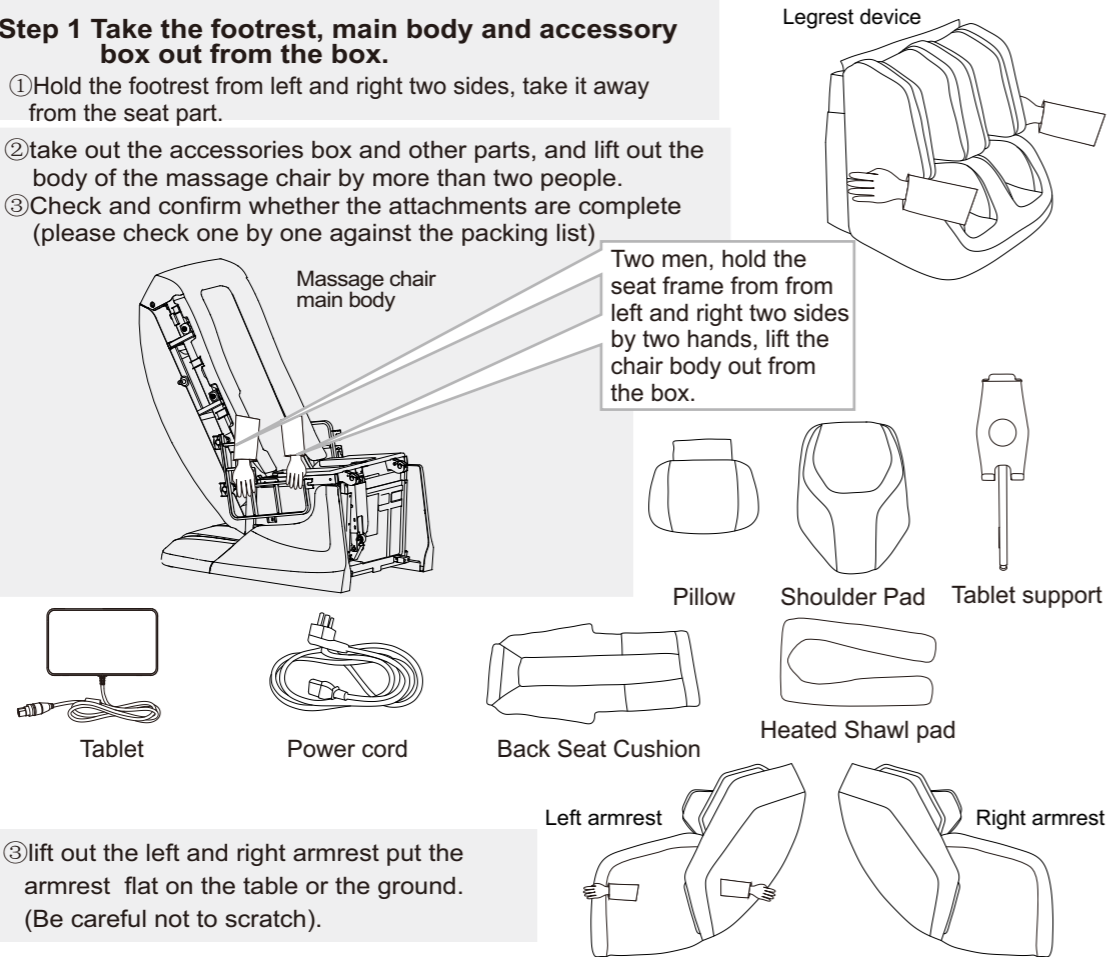

- ③ lift out the left and right armrest put the armrest flat on the table or the ground. (Be careful not to scratch).

Step 2 Put the backrest down.

- ① Align the concave position of the tablet control plug with the convex position of the tablet control wire socket on the right side of the seat, plug them together, and tighten the nut after plugging them in.
- ② Insert one end of the power cord into the power box jack and the other end into the power socket; turn on the switch button on the power box, and the chair is powered on.
- ③ Turn on the power button of the tablet control, click the posture key, and then click the zero gravity button. At this time, the backrest lowers and the seat rises. After the backrest lies down, the tablet control can be temporarily placed on the seat.
- ④ Turn off the power switch after the backrest lies down.

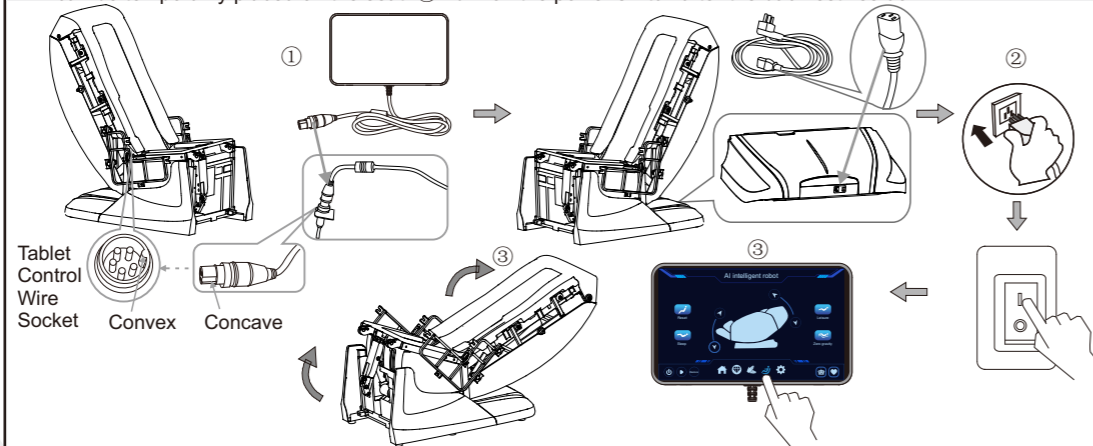

Installation 3

Step 3 Fix the left and right armrest.

- ① Remove the inner baffle on the armrest; ② Place the armrest close to the side of the chair, align the 3 fixing holes on the armrest with the 3 fixing shafts on the side of the chair backrest, and insert them into the fixing holes; ③ Insert the 2 fixing plates at the lower end of the armrest into the fixing frame on the side of the seat frame, and turn the armrest downward until it cannot be turned; ④ Fix the air pipe and wiring harness on the inside of the armrest with the air nozzle and wiring harness socket on the iron frame on the seat side; ⑤ Fix the armrest firmly with 2 M6*16 screws and washers by hex wrench; ⑥ Insert the inner baffle from the inside of the seat side baffle, and install the inner baffle on the inside of the armrest, press the periphery of the inner baffle to make the 3 buckles firmly locked, and use 4 3.9*12.7 screws to fix the baffle firmly; ⑦ And install the left armrest according to the above method. ⑧ After the left and right armrests are installed, turn on the power switch, reset the backrest and turn off the power.

Note: During installation, do not squeeze the air pipe, otherwise it will cause air leakage or airbag failure to inflate. Make sure the fixed shaft and wiring harness are firmly connected, otherwise the armrest will fall off or the convenient hand control and horn will not work.

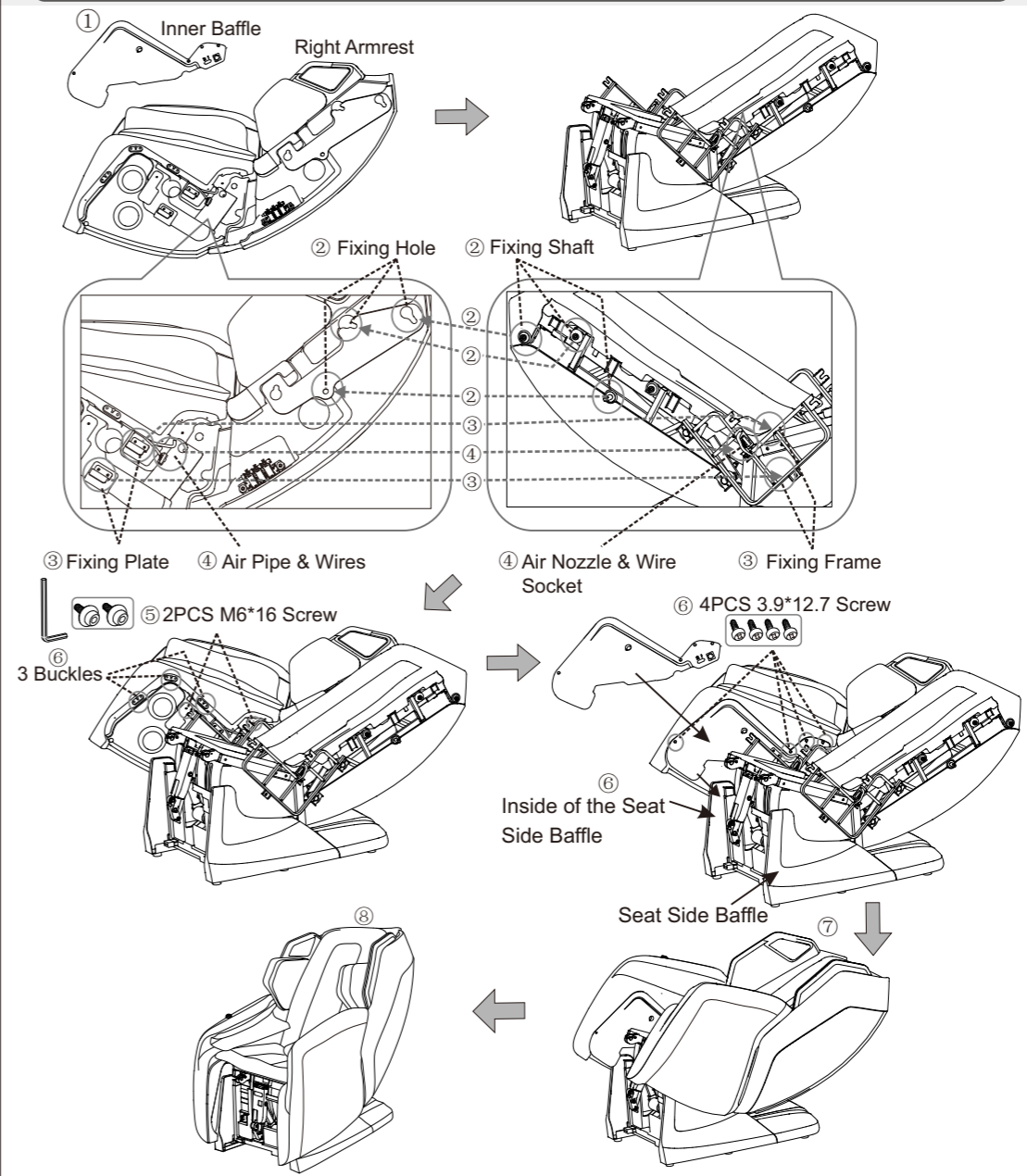

Installation 4

Step 4 Assemble legrest & Footrest

① Twist off the bolt from the metal hanger of the legrest. ② Connect the wire harness joints of the legrest with the corresponding port on the main body. ③ Connect the air tube on the legrest with the corresponding air tube joints on the main body. ④ Open the shaft cover on the metal hanger, Lift the legrest & Footrest, put the shaft into the hanger of the main body, put down the shaft cover. ⑤ Tighten the screw;

⚠ Note: Make sure the air tube and wire harness are not twisted together when plug the air tube and wire harness.

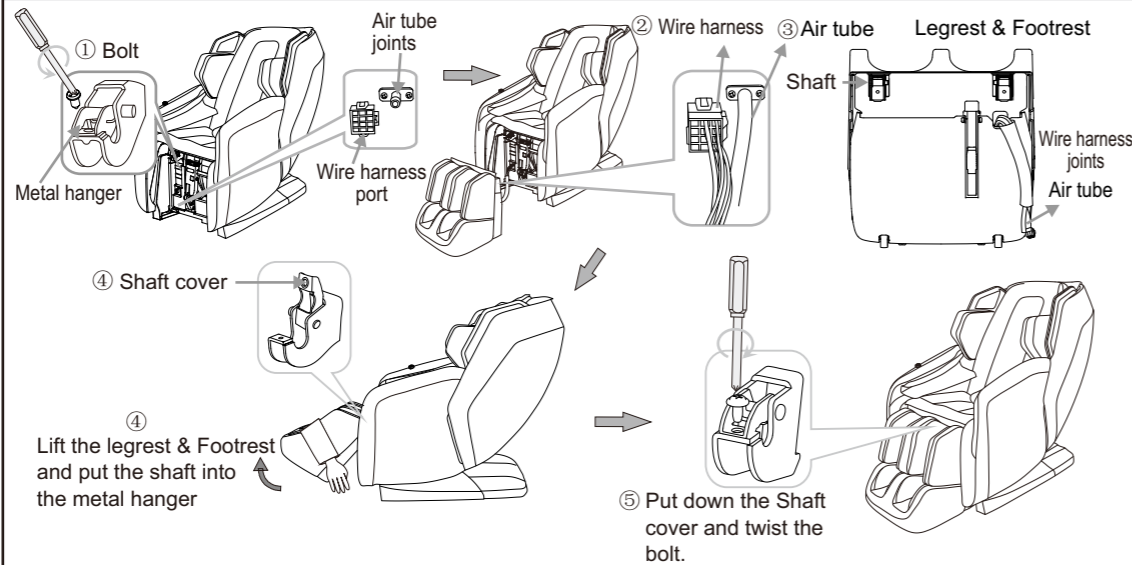

Step 5 Assemble tablet holder

① Follow the holder and base hole's shape to insert the tablet holder into the holder base till the base bolt sits in the place. ② Put the remote control on the holder.

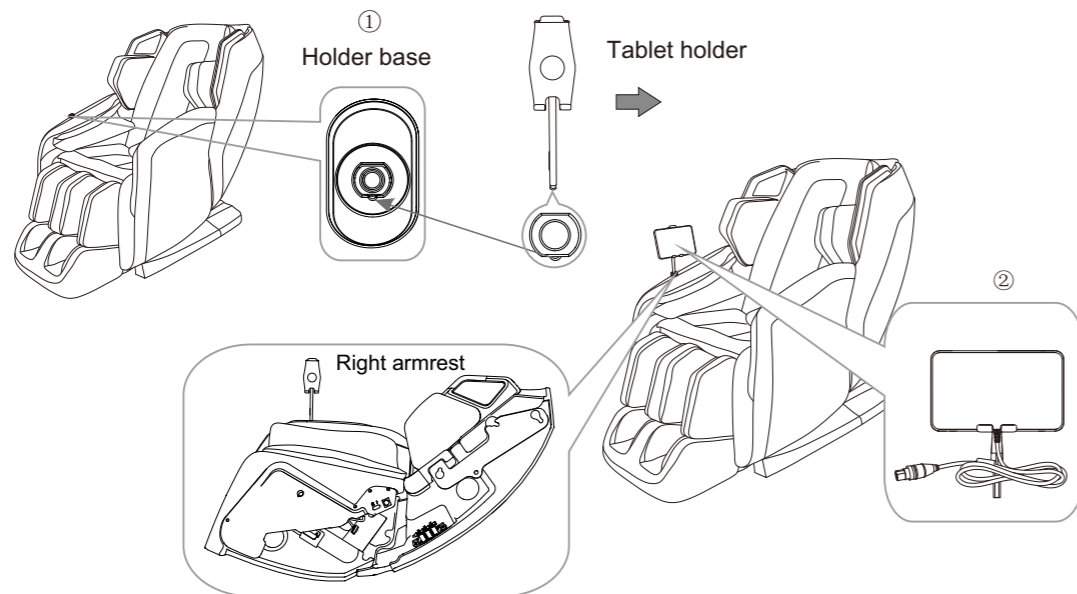

Installation 5

Step 6 Connect wire, assemble back and seat pad

Connect heat wire of the back and seat pad before zip up the back pad and the backrest.

★ Kind tips

In order to get accurate body test data, and to enjoy comfort massage, it's suggested to sit in the chair firstly, make the bottom of the pillow level with the user's ear, connect the pillow onto the backrest.

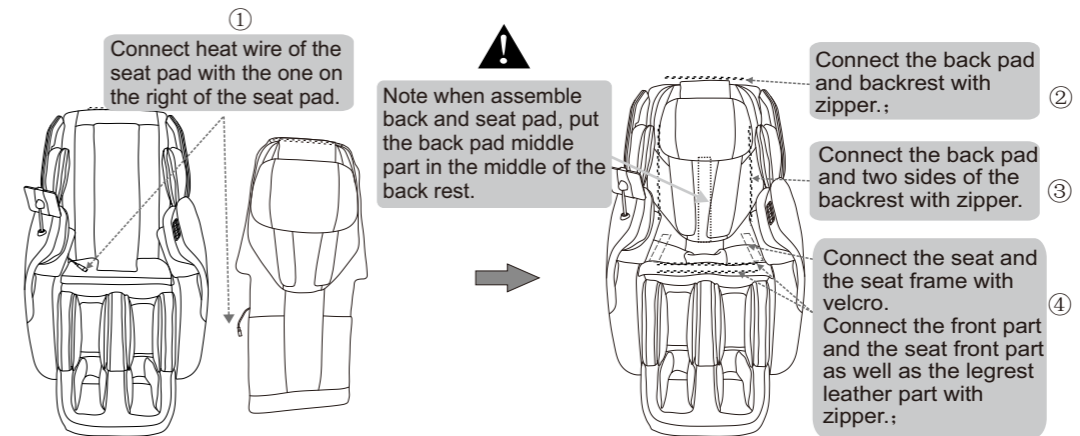

Step 7 Operation after installation

- 1 Plug the power plug into the power box socket under the backrest (Picture):
- 2 Insert the other end of power plug from the power cord into the power socket.
- 3 Turn on the power switch at the back of the power box. (Power switch "O/I", press I to connect.)
- 4 Use the fast access buttons on the armrest or the tablet hand controller to choose the massage function, enjoy this product to bring you relaxed and comfortable massage.

⚠ Before connecting the power plug to the socket, be sure to check that the power switch is in the off position.

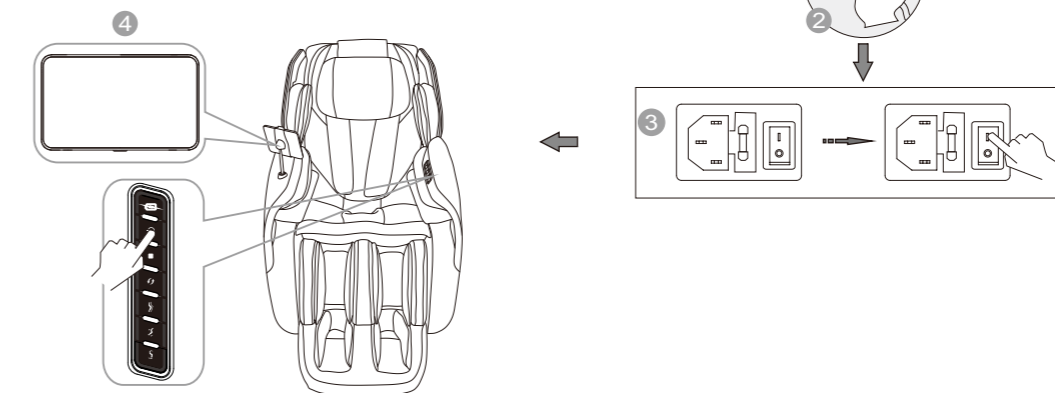

Environment



Caution



Don't use the chair in wet places like near swimming pool, bath room to avoid leakage or electric shock.



Don't use under sunlight or near stove or other heating place to avoid upholstery deteriorated.



Please use chair in flat place to avoid chair falling or noise or other unexpected trouble.

● Check places in front

Check the areas when back and leg extending, make sure no people, pets or other things around.

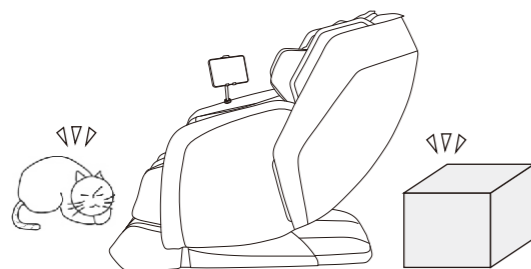

● Check power cable, plug

(1) Clean the dust on plug on time. (using dry cloth).

(2) No damage, re-do, bend, stretch, tie or press with heavy thing (especially can't be pressed by the chair) on power cable.

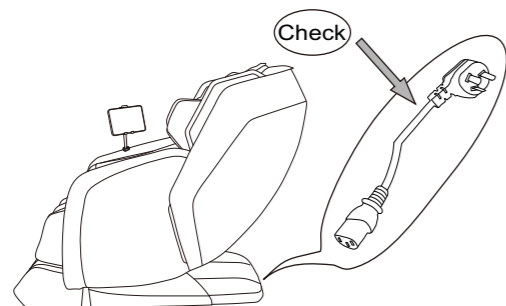

Check environment

● Space size for using the chair

- Zero space from wall.
Tips: at least 32cm from wall.

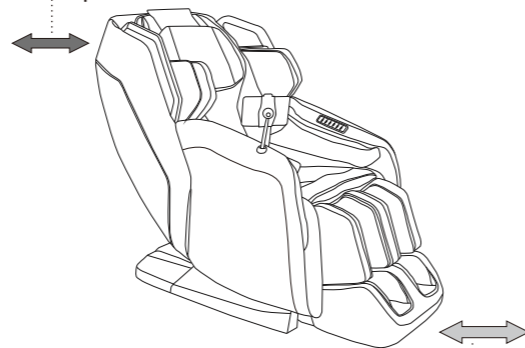

- At least 50cm in front of the leg.

● Check surroundings

When the backrest or legrest reclines or extends, please pay attention to:

- Check any person or things in every direction.
- Check the space size.

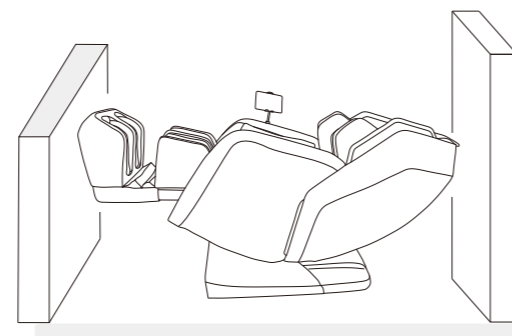
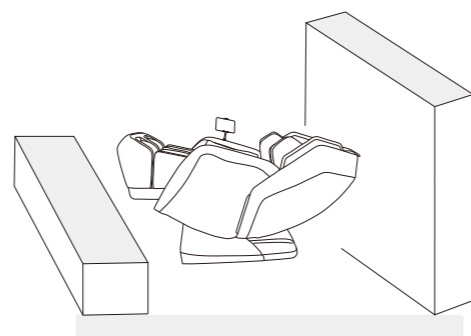

How to move massage chair



Caution

- Don't move chair when it's working in case of accidents or damage

How to move

- Bind the cables and put them in the seat to avoid damage when moving.
- If you plump the chair, it may damage the inner parts of the chair.
- Don't use the castor if the floor is wooden or other easy damaged material. It will need 2 or more persons to lift the chair.
- Make sure the power is off and the plug doesn't touch the floor (It's better to let the chair in standing status to avoid the back crashing the floor)



Normally

- Press down the head part to make the gravity fall on the back castors. Then push the chair to desired destination steadily and set it down slowly.

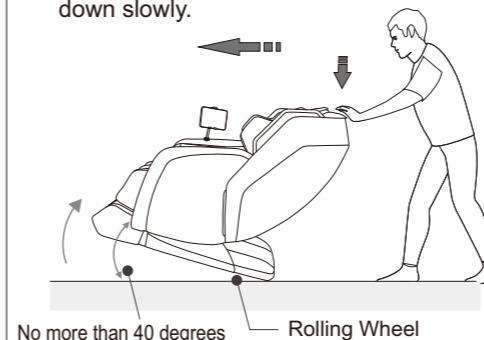

Please hold the footrest to move the chair as shown in the picture in case any scratches on the leatherette

● Kind suggestion

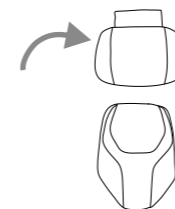

- When you feel that the massage intensity is not strong, please remove the pillow and shoulder pads, and then massage again.

Adjustment before massage

● Before adjustment

- Please make sure the mechanism roller is above the upper backrest and sit down slowly



- Avoid injury caused by improper position of massage head.

◆ Shoulder Height Detection

During the shoulder height detection, if the massage mechanism can't find the shoulder, the default position is the middle back area.

Warm reminder: Pillow pads and shoulder pads can be removed for body testing.

Proper posture: please put your back against the back of the chair and lean your head back on the pillow cushion.



Built-in Remote Instructions

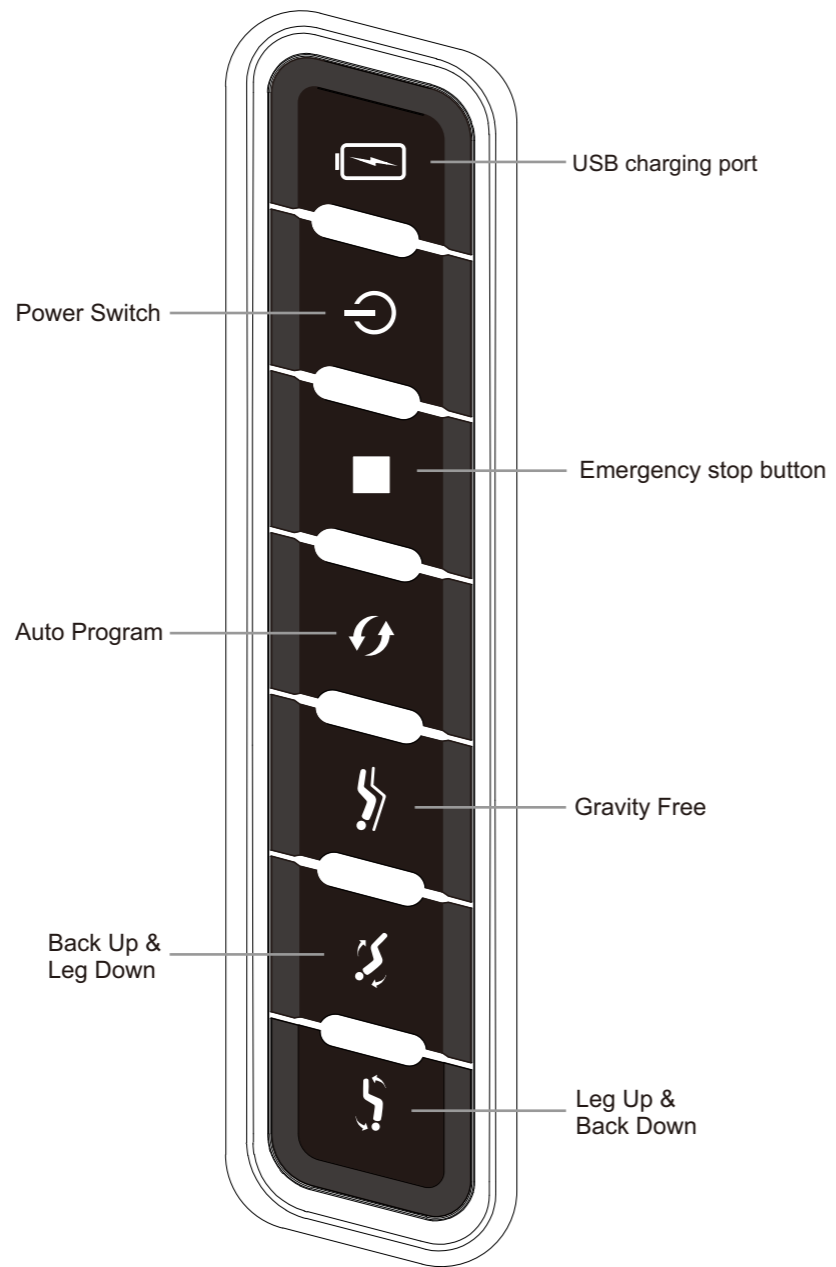

Massage operation

Tips: When the following functions are enabled, the tablet hand controller will display the status synchronously.



1. USB charging port, open the cover to connect to the Type - C charging port for mobile phone charging.



2. In the standby state, the button indicator light flashes. Click to wake up and turn on the chair and the indicator light is always on. Click again to turn off the massage chair. If it is in emergency stop state, press and hold the power button for more than 3 seconds to turn off the massage chair.



3. During the working of the massage chair, if you encounter an emergency and need to stop the massage chair urgently, you can click this button. Press this button and the indicator light will stay on. Pressing this button again will invalidate all other buttons unless you hold down the power button for at least 3 seconds, the massage chair will be closed.



4. In the power-on state, press this button to enter quick relaxation, press this button again to enter traditional Chinese medicine health care, press this button again to enter muscle stretching, and press this button again to enter pain relief. The four automatic programs cycle in sequence, and the indicator light is always on.



5. In the power-on state, press this button to adjust the massage chair to be zero-gravity state; press this button again to reset the massage chair. Such a cycle.



6. In ON status, keep pressing this key to raise the backrest and lower the legrest, release it to stop.



7. In ON status, keep pressing this key to lower the backrest and raise the legrest, release it to stop.

Massage operation

Tablet remote control operation

Tablet Remote Control



LCD Touch Screen

1. Tablet is ON by default after the chair is powering on and will display the ON interface. If no operation over 2mins, the tablet will go dark.

Theme message interface

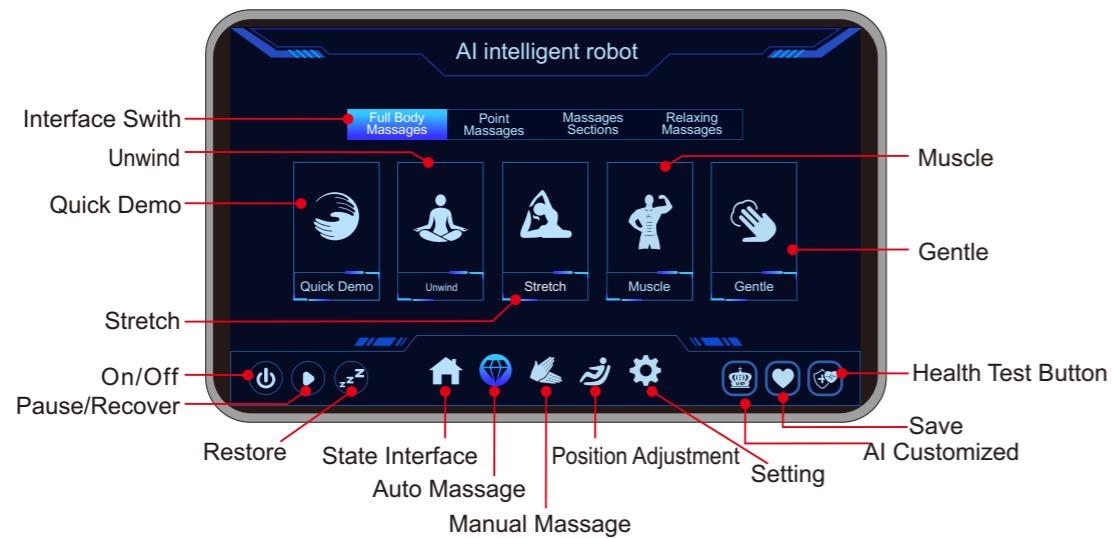

Quick Demo
In the ON status, press this icon to enter Quick Demo mode, default working time for this auto program is 8 minutes.

Unwind
In the ON status, press this icon to enter Chinese Massage mode, default working time for this auto program is 20 minutes.

Massage operation

Tablet remote control operation

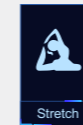

In the ON status, press this icon to enter stretch mode, default working time for this auto program is 20 minutes.

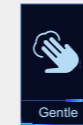

In the ON status, press this icon to enter Gentle mode, default working time for this auto program is 20 minutes.

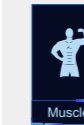

In the ON status, press this icon to enter the Muscle mode, default working time for this auto program is 20 minutes.



On/Off key, click it, it will light up, the chair will start working after powering on.



End & reset Button: during the button in light up state, the message chair will not reset when the countdown ends; after the button light is canceled, the message chair will reset when the countdown ends.



Auto massage key, click it to enter auto message interface.



Position adjustment key, click it to enter position adjustment interface.



AI customized key, click it to enter customized setting interface.



Health Test Button: Click to enter the Health TestInterface.



Pause/Recover key, click it to stop all message functions, click it again to continue all message functions.



Homepage interface key, click it to enter Homepage interface.



Manual message key, click it to enter manual message interface.



Setting key, click it to enter setting interface.



Save to my favorite key, click it to enter my favorite interface to save or delect favorites.

Massage operation

Message Interface

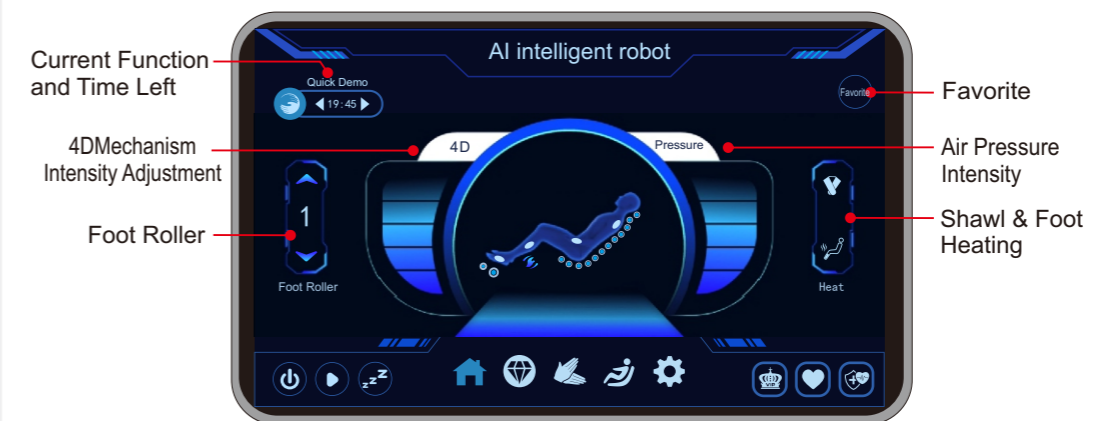

Favorite
Click Favorites icon to save the current running program, you can save up to 8 favorite programs. The screen will display a message indicating the favorites are full if you save 8 favorite programs, and the page automatically switches to the status page after 8 seconds.



Foot roller key, click it to turn on/off foot roller function.



Shawl and Foot Heating Button: Click to light up the button with three heating levels.



Click this button to adjust 4D intensity, Click the upper area to 4D+, Click the lower area to 4D-.



Click this key to adjust the air pressure intensity.



The body icon can display the current heating, massage mech position and roller status.





Massage operation

Massage operation

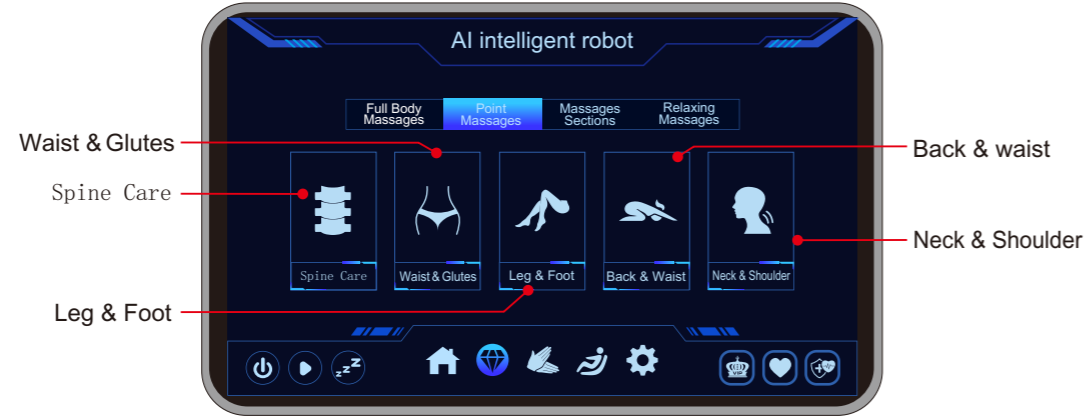
Tablet remote control operation

Partial massage interface

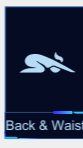

-  In ON status, click and light up the icon to start Spine Care Massage.
-  In ON status, click and light up the icon to start Waist Glutes Massage.
-  In ON status, click and light up the icon to start Leg and Foot Massage.
-  In ON status, click and light up the icon to start Back and Waist Massage.
-  In ON status, click and light up the icon to start Yoga Massage.





Various massage interface



Massage operation



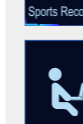

Massage operation

Tablet remote control operation

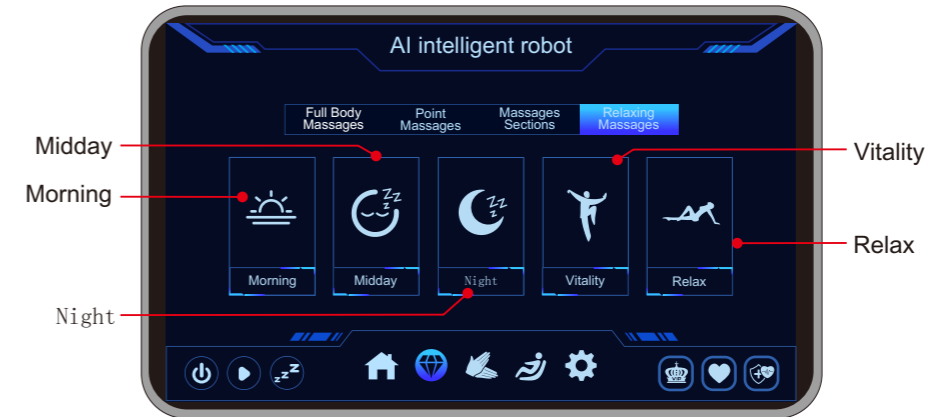
-  In ON status, click and light up the icon to start Upper Body Massage.
-  In ON status, click and light up the icon to start Glutes Massage.
-  In ON status, click and light up the icon to start Sports Recovery Massage.
-  In ON status, click and light up the icon to start Lower Body Relaxation Massage.
-  In ON status, click and light up the icon to start Office Relief Massage.

Leisure massage interface



-  In ON status, click and light up the icon to start Morning Massage.
-  In ON status, click and light up the icon to start Midday Massage.
-  In ON status, click and light up the icon to start Night Massage.
-  In ON status, click and light up the icon to start Vitality Massage.
-  In ON status, click and light up the icon to start Relax Massage.

Massage operation

Tablet remote control operation

Position Adjustment Interface

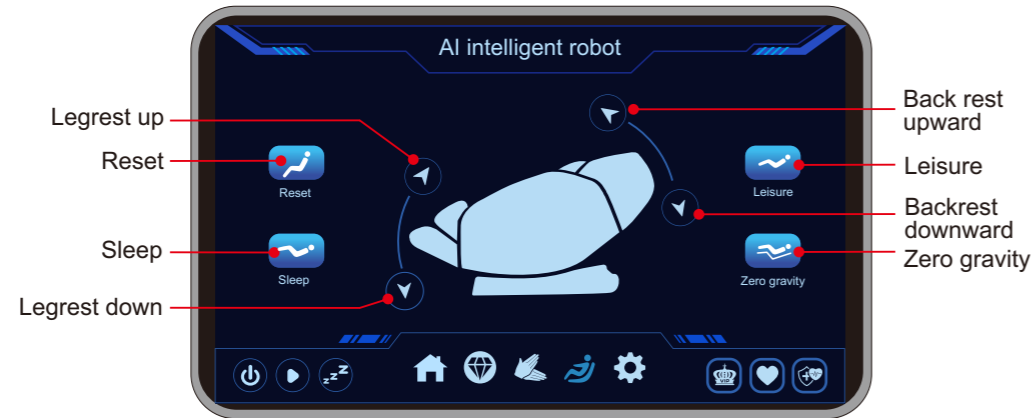

Massage operation

Manual Massage Interface

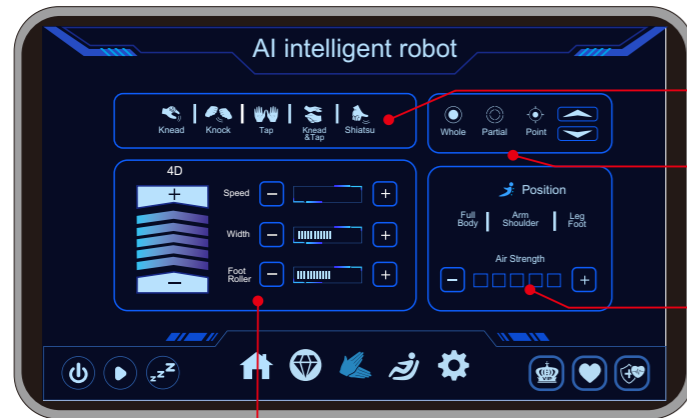

Message Technique: Kneading, Knock, Tapping, Knead+Tap, Shiatsu.

Position: Whole, Partial, Point, Upward, Downward.

Air Massage: Full Body, Arm Shoulder, Leg Foot.

4D Adjustment Menu. Massage speed, width and foot roller adjustment.

Tablet remote control operation

Customized Interface Mechanical Message Interface Display

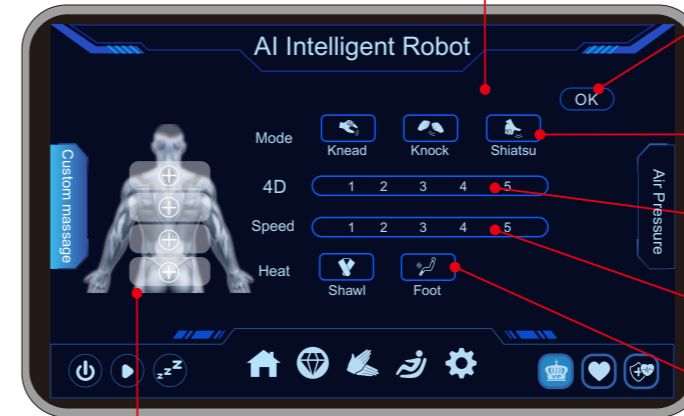

After completing the settings, click the "OK" button to run the customized program.

Mode and Technique Selection Menu: Emphasizing Kneading, Emphasizing Tapping, and Emphasizing Shiatsu are the three techniques.

The 4D intensity setting uses a slider with a default of 3 levels.

The massage mechanism speed setting uses a slider with a default of 3 levels.

Heating Setting: Shawl and foot heating can be turned on.

By AI customized position key, you could choose four position including Neck & Shoulder, Back, Waist and Hips with corresponding display. If enter AI customized from other interface, the original position and state will keep no change.

Massage operation

Customized Interface Air Pressure Message Interface Display

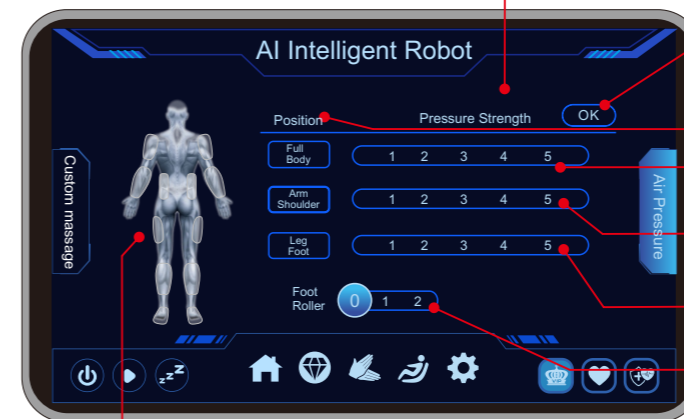

Click the OK key to ensure the customized program .

Airbag position key, can adjust the level after selected.

Whole Air Pressure Intensity Setting Slider, defaulting to level 3.

Arm Shoulder air pressure intensity setting slider , defaulting to level 3 .

Leg Foot air pressure intensity setting slider , defaulting to level 3 .

Foot Roller Setting Slider

Full Body Airbags Display Status, illuminated means selected.

Tablet remote control operation

My Favorite Interface



It can save eight programs at most. Click the program and long press to remove. Manual mode can't be saved. The saved programs will be saved even if out of electricity.

Settings Interface

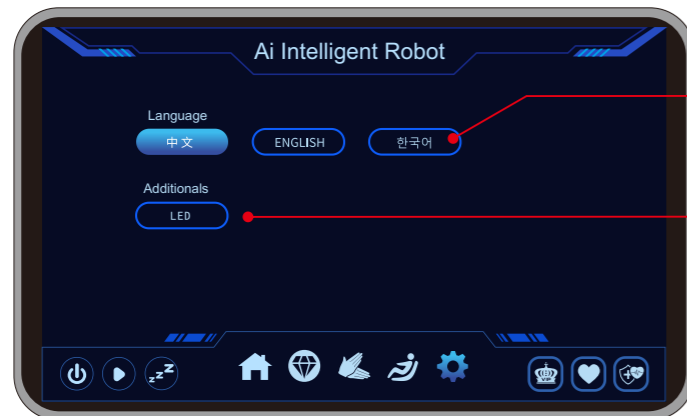

Language setting, Chinese, English and Korean is available.

LED Light : Turn on /off the LED light .

Massage operation

Tablet remote control operation

Health Test Interface

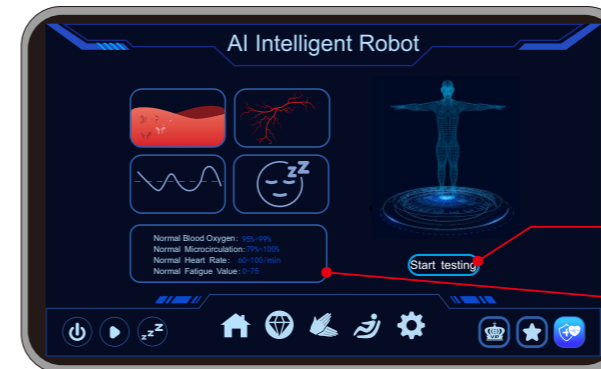

Test Note: Please kindly adjust to the most comfortable position, put index finger on the sensor of right armrest. Be relax and adjust breath, click start testing, enter the test progress interface.

Start testing. Click it to do health test.

Blood oxygen, microcirculation, heart rate and fatigue level data are only for reference.

Health Test Progress Interface

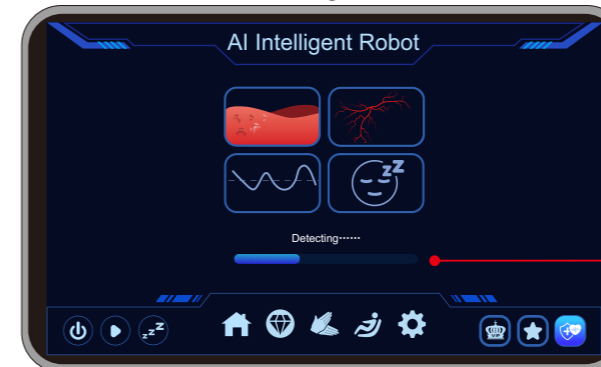

Health Test Progress Bar

Health Test Result Interface

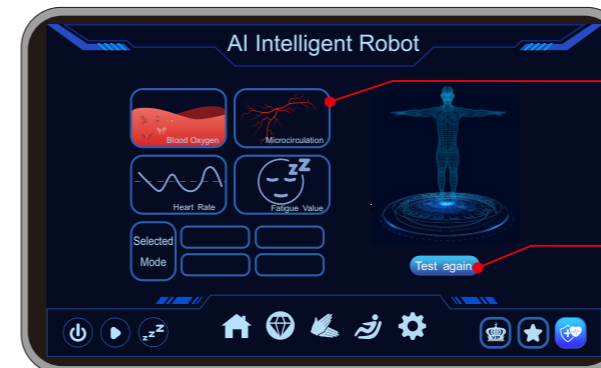

Blood oxygen, microcirculation, heart rate and fatigue level data will come out after detection.

Click it to test again.

Body scanning interface

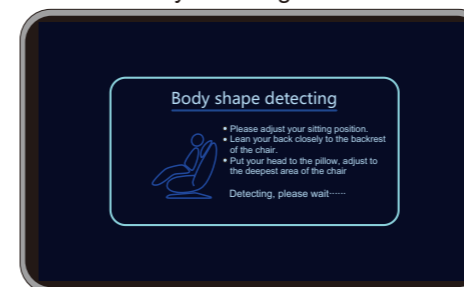

Body scanning finished, enter into manual shoulder height position adjustment interface.

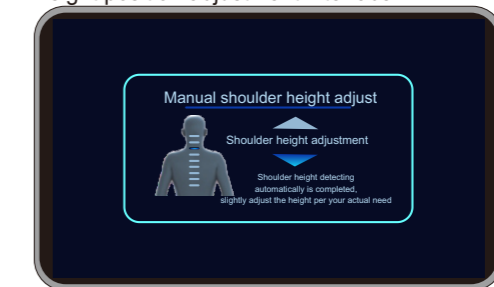

Massage operation

Restoration of the massage chair

- 1 Confirm whether there are people, pets or other items in the movement range of this chair's backrest or leg-rest.

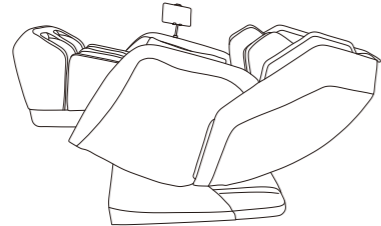

- 2 Use a manual controller to slowly restore the backrest and legs to their original position. (Or to directly press the "switch" button off can also make the backrest and leg-rest slowly return to their original position.)

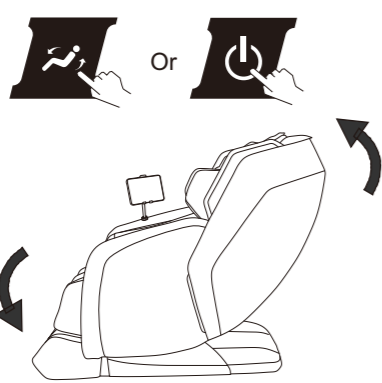

- 3 After being stored, put the hand controller back on the tablet bracket of right armrest.

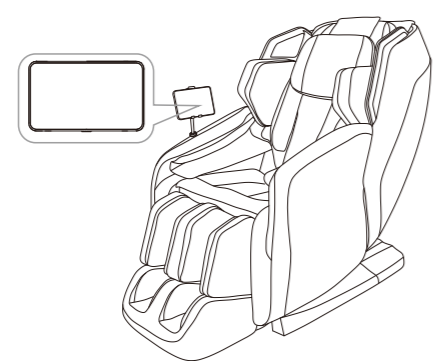

- 5 Turn off the power switch.

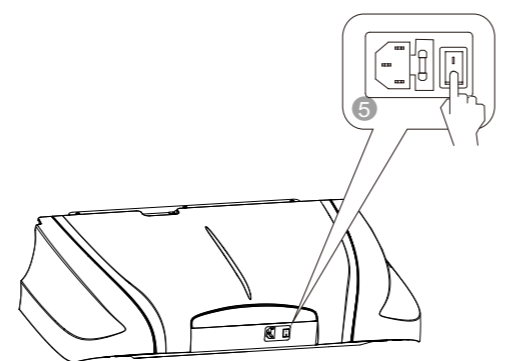

- 6 Unplug the power plug from the power socket. (Attention: hold the right plug position)

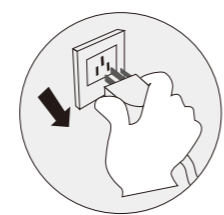

- 7 Do proper tidies and cleaning.

Attention

- After the massage, press the "on/off" button to turn off all the massage movements and wait for the massage rollers to be collected and put in place.
- After use, make sure the power supply is disconnected to avoid accidental injury to children or other pets.
- After use, turn off the power switch, pull out the power cord plug, Environmental protection and energy saving.
- Avoid pulling the power plug by pulling the power cord alone. Avoid damage caused by moisture, dust and degradation of insulation.

Synthetic leather

- **General cleaning**
Clean with tidy, soft and dry cloth slightly.

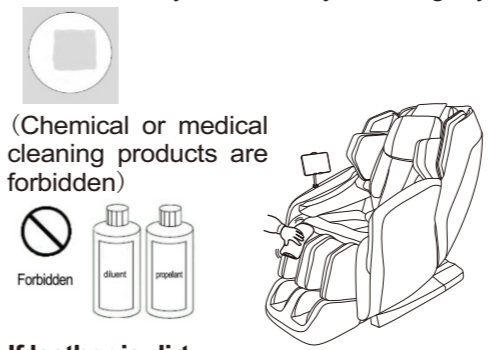

- **If leather is dirty**
 - 1 Dip soft cloth into 3-5% neutral detergent solution, squeeze it then clean the stain on the surface gently.
 - 2 Wash cloth, squeeze it and wipe with detergent.



- 3 Clean it softly with dry cloth.
- 4 Allow to dry (air blower is prohibited)

Cloth material

- 1 Dip cloth into weak neutral detergent, squeeze it and clean the material surface.
- (Diluent, gas, alcohol are prohibited)
Brush the dirty parts with weak neutral detergent. (avoid excessive brushing)
- 2 Excessive cleaning may cause damage to cloth material.
- 3 Wipe with water-dipped but squeezed cloth.
- 4 Allow to dry.

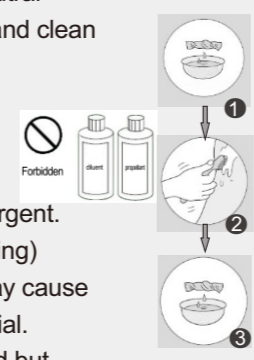

Plastic parts

- 1 Dip cloth into neutral detergent, squeeze it and clean.
- 2 Wipe with water-dipped but squeezed cloth.
- 3 Allow to dry.



Clean the controller

- 1 Wipe with soft cloth after squeezing.
- 2 Allow to dry. Propellant, diluent or alcohol are prohibited.

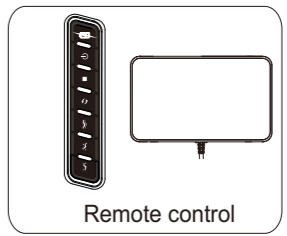

Maintenance

Massage operation



About cleaning

- Before cleaning, unplug the electricity, don't touch plug with wet hands.
- Make sure hands are dry when plugging to the socket.
- If failed to follow the mentioned instruction, user may get electric shock or burned.

FAQ and Troubleshooting

Trouble	Possible reason	Troubleshooting
The massage chair can't work after power is on.	Check if the control is on or not.	Open control switch
	Not choose massage function	Choose massage function
	Check whether the plug and socket in poor contact.	Make sure plug and socket are connected.
	Wire or plug has damaged.	Please ask manufacturer or appointed or authorized maintenance man for checking and replacement.
	The fuse burned out.	Replace fuse of same specification.
	Something wrong with inner circuit	Please ask appointed or authorized maintenance man for checking and repairing.
There is beep sound inside the massager while working.	It is sound of air pump, motor and mechanical parts.	Normal sound, no need to pay attention to it.
Different height of the left roller and right roller.	Massage rollers work on shifts.	Normal, no need to pay attention to it.
Sound suddenly becomes much louder while working.	Check if it is due to long time working.	Turn off the power to have the massager rest for over half an hour before next turn working.
	Inner parts fretted away due to long time work. It's normal	Please ask appointed or authorized maintenance man for checking and repairing.
Massage function suddenly stops while working.	Suddenly power-down	Connect the electricity power again
	Setting time is up.	Turn off the power to have the massager rest for over half an hour before next turn working.
Neither the backrest nor the legrest can be lay down.	Check if there are any obstacles; the chair overloads; for the sake of safety, sometimes the massage machine may automatically stop working. There is heavy things on power box.	Remove the obstacles; turn off the power to have the massager rest for over half an hour before next turn working.
The chair can't return to its original position.	Excessive operation; setting time is up.	Please ask manufacturer or appointed or authorized maintenance man for checking and replacement.
Electric wire or plug give out heat	It may work overload	Turn off the power to have the massager rest for over half an hour before next round working.
	Other abnormal case	Stop using, and ask appointed maintenance man for help.



Note: If the troubles are not caused by above reasons, please turn off the power switch and cut off the power, then contact the manufacturer or service agent to repair your chair.

Others

Technical data

Name	Massage Chair	Power	220W
Model	RK8906A	NW/GW	Main body :108.8/127.8kg Armrest :39.4/47.5 kg
Input voltage	120V~ 60Hz		
Safety design	Class I	Packing size	Main body:1250×820×1300 mm Armrest : 1065×520×820 mm (L×W×H)

Others