

J's ALARMS REMOTE START

THIS IS YOUR IGNITION CYLINDER

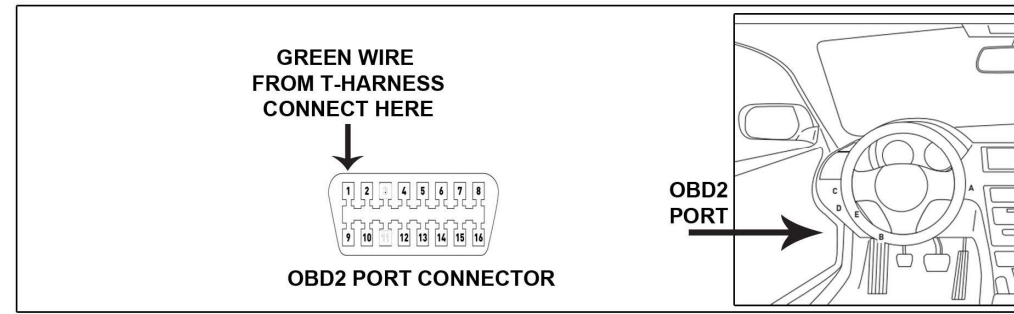
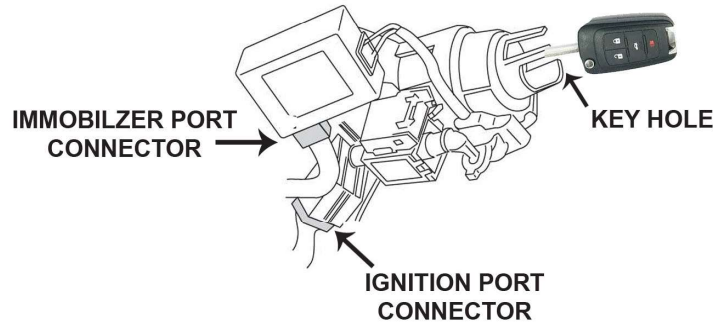

**YOU ARE NOW DONE WITH CONNECTIONS
TIME FOR MODULE PROGRAMING**

1. PRESS AND HOLD BLACK PUSH BUTTON ON MODULE
2. PLUG IN BLACK PLUG TO MODULE, HOLD FOR 3 SECONDS, LIGHT WILL FLASH RED, NOW RELEASE BUTTON
3. NOW CONNECT BLUE CONNECTOR
4. INSERT & TURN KEY TO ON, WAIT LIGHT WILL FLASH GREEN
5. TURN KEY OFF & REMOVE KEY, LED WILL TURN RED
6. INSERT KEY & TURN KEY TO ON, LED WILL TURN OFF
7. TURN KEY OFF AND REMOVE KEY
8. INSERT KEY & TURN TO ON, WAIT LED WILL TURN GREEN FOR 2 SEC
9. TURN KEY OFF & REMOVE KEY

**YOU ARE NOW DONE!
TO START VEHICLE PRESS
LOCK, LOCK, LOCK
ON REMOTE CONTROL**

NOTE: SOME VEHICLES (CARS) THE REMOTE CONTROL WILL GO TO SLEEP WHEN THE VEHICLE IS STARTED. THIS IS A SAFTEY FEATURE CHEVY/GMC ADDED TO THE VEHICLE AND IS NOT OUR UNIT. IF YOUR REMOTE GOES TO SLEEP YOU WILL NEED TO USE YOUR METAL KEY TO UNLOCK THE DOOR AND ENTER VEHICLE ONLY WHEN YOU REMOTE START THE VEHICLE. ALL OTHER TIMES IT WILL WORK JUST LIKE NORMAL. WE DO SELL RF KITS ON BACK PAGE IF YOU WANT TO CONTROL DOOR LOCKS WHEN THE VEHICLE IS RUNNING.

TECH SUPPORT MONDAY-FRIDAY 9AM TO 5PM PST

559-264-9111

STEP 1. UNPLUG VEHICLE SIDE IGNITION PLUG > PLUG INTO VS3 > PLUG IN VS4 TO IGNITION PORT CONNECTOR

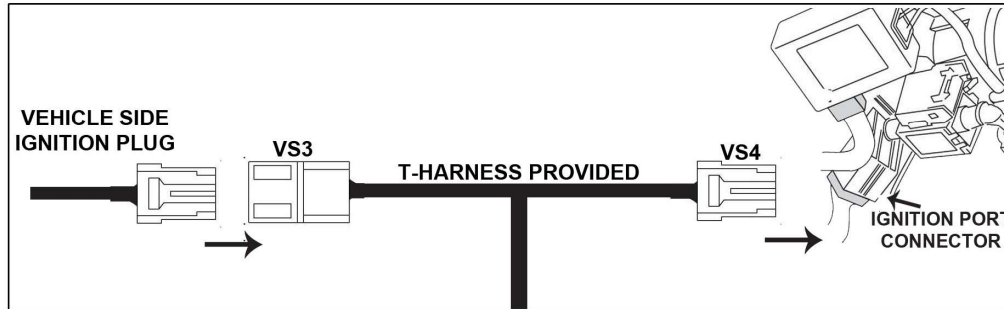

ONLY 2014+ TRUCKS & SUV MUST USE JS1 CONNECTOR

PLUG JS1 TO VS4 (LEAVE VS3 UNPLUGGED) | VS5 TO IGNITION PORT | VS6 TO IGNITION PLUG

STEP 2. UNPLUG VEHICLE SIDE IMMOBILIZER PLUG > PLUG INTO VS1 > PLUG IN VS2 TO IMMOBILIZER PORT CONNECTOR

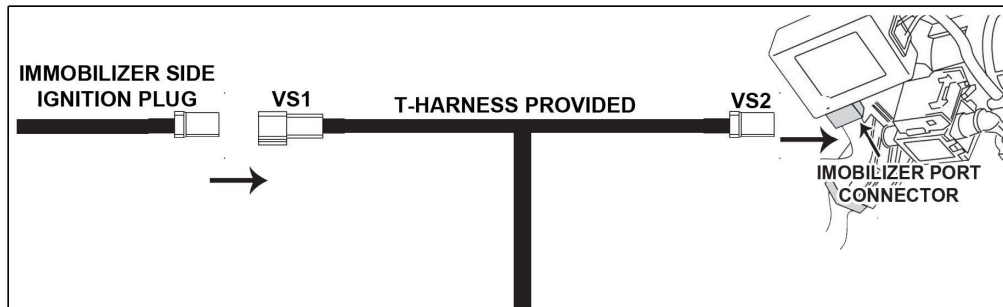

STEP 3. CONNECT GREEN WIRE TO PIN #1 ON OBD2 PORT (MAKE CONNECTION BY PEELING WIRE BACK AND WRAPPING OUR WIRE AROUND)