



Measuring Guides

www.silkandstitch.co.uk

Measuring Guide

Roman Blinds

Inside the Recess

Step 1:

Take three width measurements inside the recess, as your window may not be perfectly square. Use the smallest measurement and subtract 1cm to determine the final width.

Step 2:

Measure the window's length in three different spots and select the smallest measurement as your final length.

Tip:

Ensure there are no obstacles that could interfere with your blind. Need assistance? Reach out to us for expert guidance.

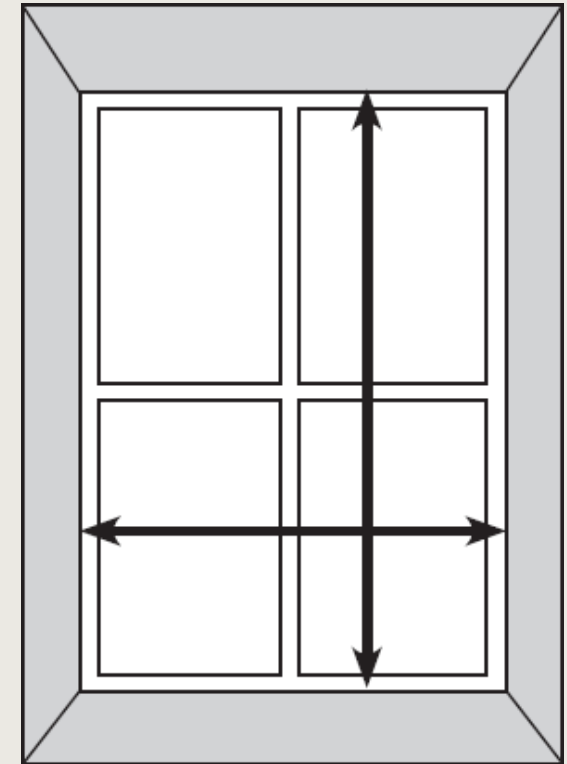

Measuring Guide

Roman Blinds

Outside the Recess

Step 1:

Choose where you want your blind to be positioned. We suggest mounting it about 15cm above the recess. The bottom of the blind should either rest on the sill (if it protrudes) or extend roughly 10cm below it.

Measure from the top of the blind's position to the desired length in three places, then use the smallest measurement as your final length.

Step 2:

Measure the width of the recess and add 5cm on each side. This will be your final width.

Tip:

Ensure there are no obstacles that might obstruct the blind. Need assistance? Get in touch with us for expert advice.

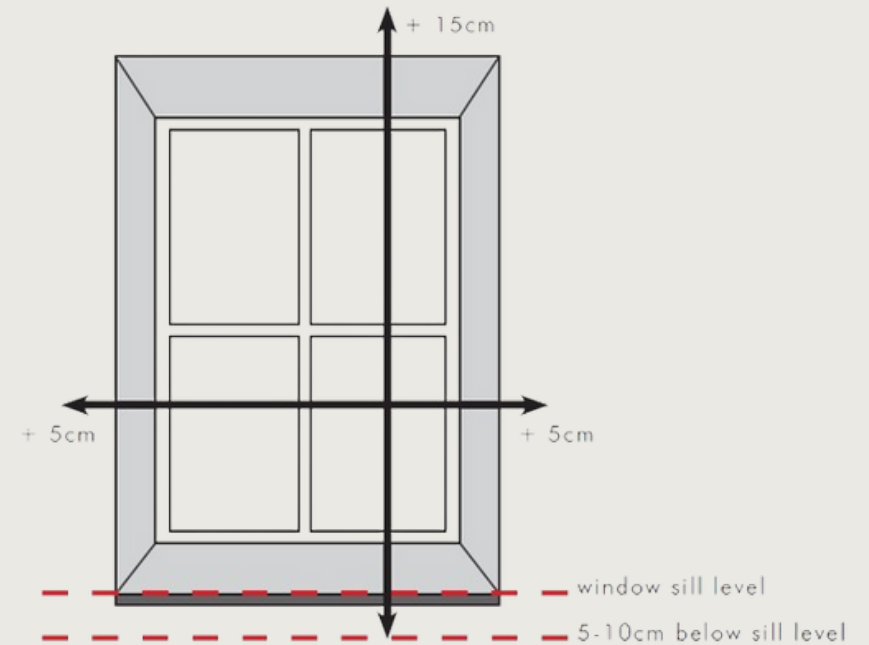

Measuring Guide

Roman Blinds

Bay Windows - Inside the Recess

What you will need:

- 2 pieces of A4 or A5 paper or card
- A metal tape measure
- A pencil
- A ruler

If you have any handles or vents on the windows, measure in millimetres how far out from the window frame they protrude. You'll need to add this measurement to the 'depth' of your roman blind which is 50mm/5cms.

Mark this result as Dimension A.

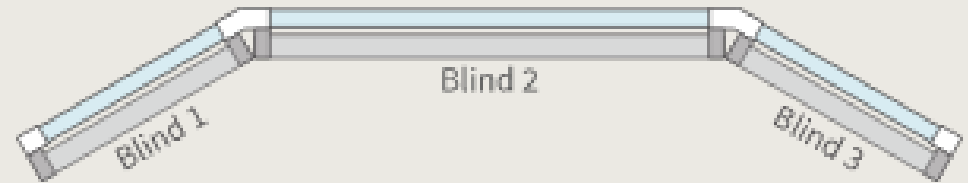

Measuring Guide

Roman Blinds

Bay Windows - Inside the Recess

Step 1:

Place two pieces of paper edge to edge. Using a ruler, measure Dimension 'A' from the back edge and mark this point on both pieces of paper.

Step 2:

Position the papers on the windowsill, one on each side of the bay window corner, ensuring they are flush against the window frame. Slowly slide them toward each other until the two marks align.

Step 3:

Use a pencil to mark the exact spot on the windowsill where the paper meets the window frame. Repeat steps 2 and 3 for each bay window corner.

Step 4:

Measure the distance between each set of marks accurately and record these measurements. These will be the exact widths of the blinds you need to order.

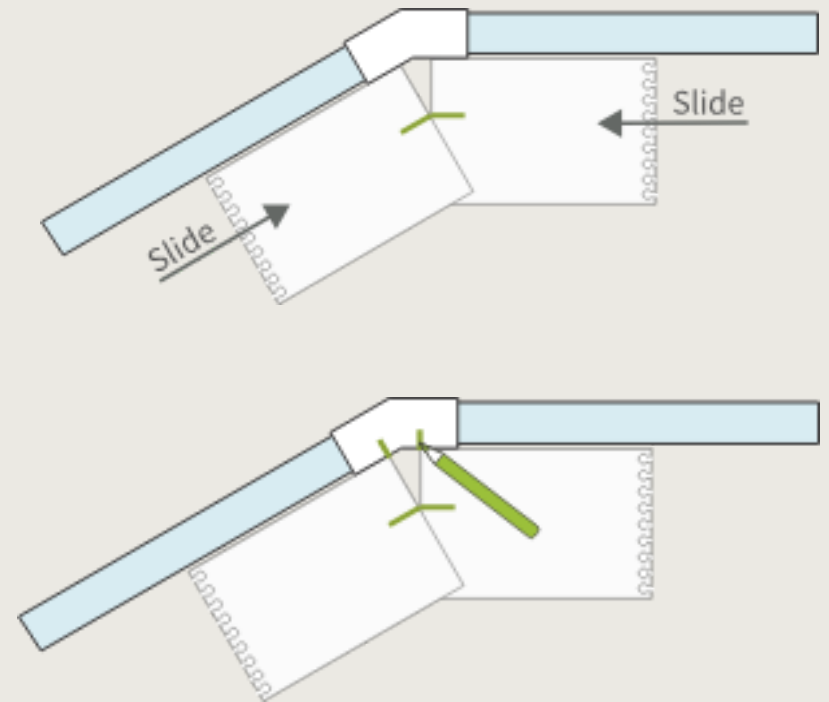

Measuring Guide

Roman Blinds

Bay Windows - Inside the Recess

To determine the drop of your blinds, measure from the top of your desired fitting position down to where you want the blinds to end, typically at the window sill if one is present. Take measurements in at least three different spots across the bay window and use the smallest one.

For Vertical Blinds, subtract 12mm from this measurement to prevent the fabric louvres from touching or dragging on the sill.

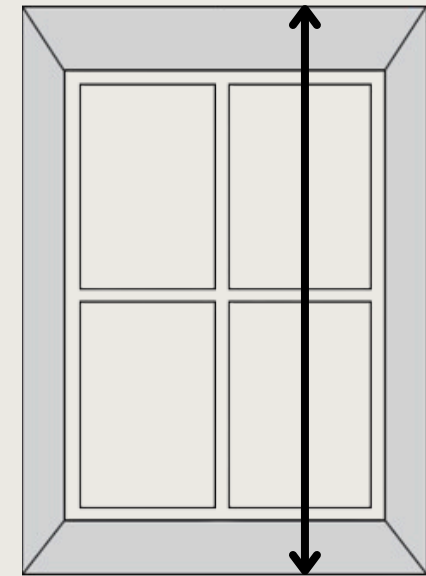

Measuring Guide

Curtains

Step 1:

Determine the width. If using a curtain pole, measure the length between the end finials. If using a curtain track, measure the full width of the track.

Step 2:

Measure the length. For a curtain pole, take the measurement from the small metal ring at the bottom of each curtain ring. For a track, measure from the top of the track—ideally aligning the top of the curtains with it.

For floor-length curtains, measure from your preferred starting point down to the floor or 1cm above.

For "kicked" length curtains, add 3cm to the drop.

Tip:

Install your curtain pole or track before measuring for curtains.

Take measurements in three places and choose the most suitable length.

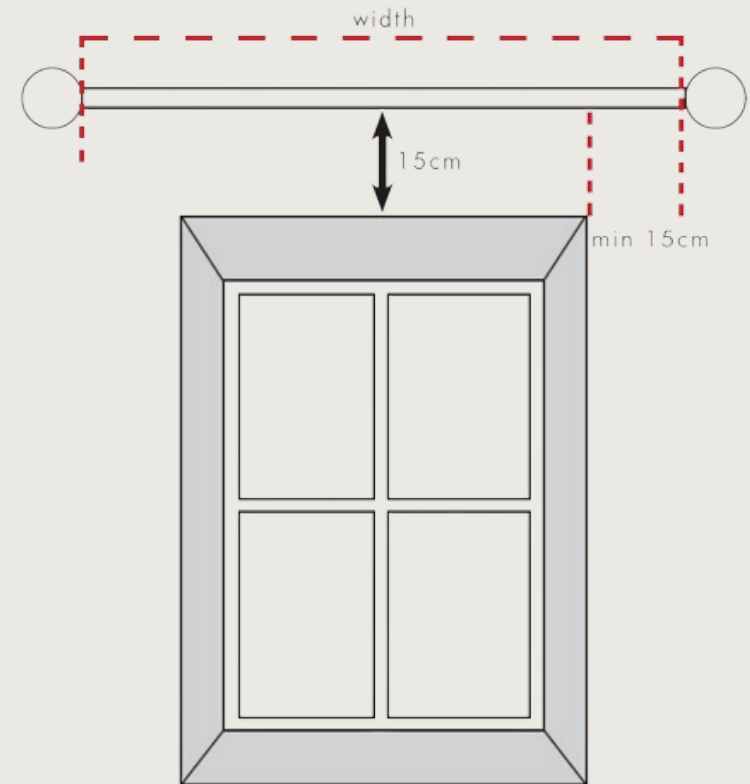

Curtains and Blinds

Hand Sewn

Our Roman blinds and curtains are meticulously hand-sewn using traditional techniques for a durable and refined finish. One of the key benefits of hand-sewn blinds and curtains is the absence of visible stitches on the front, creating a sleek, high-end appearance.

Lining Options:

We offer several types of linings to suit different needs:

- Polycotton Sateen Lining as standard
- Blackout Lining
- Interlining

Additionally, we provide a variety of lining colours and can recommend the best match for your chosen face fabric.

We highly recommend interlining for all blinds and curtains, interlining is a soft, thick layer sewn between the face fabric and lining.

Let us help you choose the perfect combination for a beautifully finished product!

