

Biochar Production Technologies

USDA ARS-AFT-USBI Practical Biochar Implementation

November 29, 2023 <https://bit.ly/47kufav>



Tom Miles
Executive Director
US Biochar Initiative

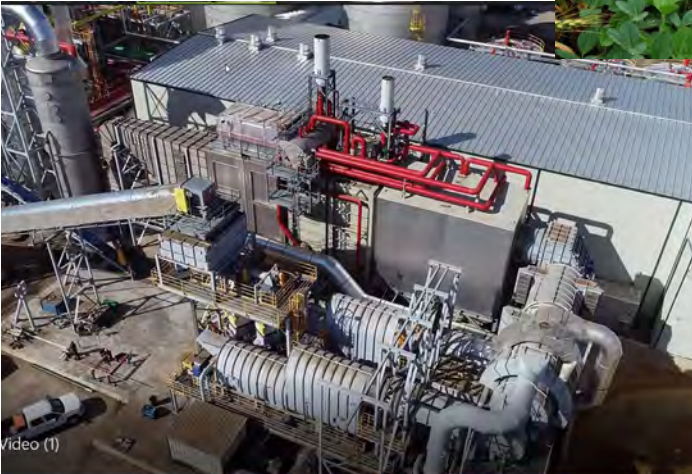
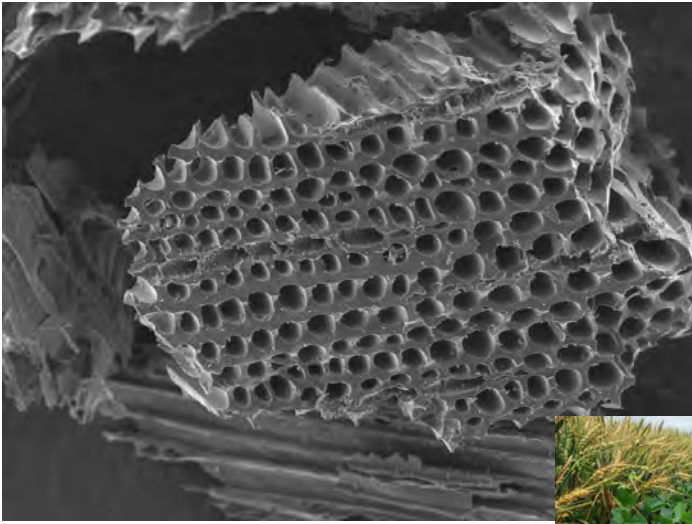

American Farmland Trust
US Biochar Initiative
USDA Agricultural Research Service



ABOUT USBI

Established 2009

USBI is a not-for-profit organization promoting the sustainable production and use of biochar through research, policy, technology & doing it!

Networking – Education - Demonstration

Activities:

North America Conferences, Workshops, Demos, Fact Sheets, Newsletter, Website, Provider Directory, Social Media, Biochar Advocacy, Referrals, Forestry Partner, Technical Advisory Team, Research, Outreach & Education, biochar.groups.io



Concerns about the high cost of growing media, recent supply chain issues, and worries about the environmental impacts of peat have spurred interest in alternative media for the horticulture and turf industries. Biochar offers the potential of a natural, local, and sustainably sourced alternative to peat and other common growing ingredients including:

Economic benefits

- Increase plant survival: Increase plant survival! Certain types of biochar have shown an increase in water holding

Fact Sheets



Online Producers Directory



Equipment & Technology Development



In-field Workshops



Trade shows & Conferences



biochar-us.org/biochar-crop-application-guidelines



Practical Implementation: Biochar Production Technologies

2024 North American Biochar Conference

FEBRUARY 12-15, 2024
SAFE Convention Center
Sacramento, California, USA



REGISTER NOW

<https://www.biocharconference.com/>



Right source

Selecting the best biochar for your crop

Right place

Applying biochar to the soils that need it

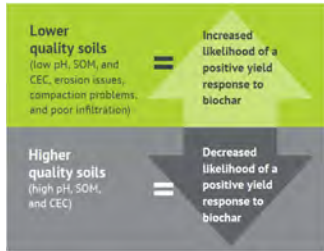

Right rate

Applying the right amount

Right time

Identifying when to apply

US BIOCHAR INITIATIVE BIOCHAR-US.ORG

BIOCHAR GUIDELINES FOR AGRICULTURE APPLICATIONS

Practical insights for applying biochar to annual and perennial crops



Photo by Britt I assum



Photo by David Laird

A sustainable soil amendment that:¹⁻⁴

- builds soil organic carbon and soil health
- increases crop yields and soil moisture
- improves nutrient retention
- boosts microbial activity
- alleviates compaction
- reduces soil acidity
- sequesters carbon



Biochar 2024
Feb 12-15, 2024
Sacramento,
California

Biochar Production Technologies: Topics

Introduction

Feedstocks

Pyrolysis

Biochar

Products

Biochars

Biochar based

Technologies:

Place Based

Mobile, Portable

Stationary Systems

Small

Medium

Large

Transportation and Handling

Small bulk

Bags

Bulk

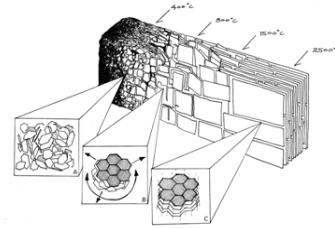
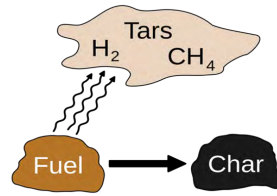



Right Biochar Source

➤ Sources

- Local Biochar/Feedstock
- Available
- Waste

➤ Feedstocks

- Wood
- Ag Pits, Nuts, Shells
- Litters
- Manures
- Straw, Stalks

➤ Quality

- Analysis
- Needs

➤ Process

- Feedstock
- Temperature
- Residence Time

➤ Objectives

- Filtration
- Infiltration, Aggregation
- Water retention
- Nutrient Use
- Organic matter
- pH
- Carbon
- Soil Health

What is biochar?

- Biochar is the solid product from pyrolysis of biomass
- High in C ~ 60-80% C
- Highly porous, low bulk density
- Highly aromatic
- Highly recalcitrant in soil
- **A versatile soil amendment and environmental material**
- ***Produced via pyrolysis: heating without oxygen***



What is **pyrolysis**?

- Pyrolysis is the conversion of biomass through heating at moderate temperatures (350-900°C) and **in the absence of oxygen**
- Pyrolysis of biomass produces
 - Gases: H₂, CH₄, CO, CO₂, etc.
 - Bio-oil
 - **Biochar**

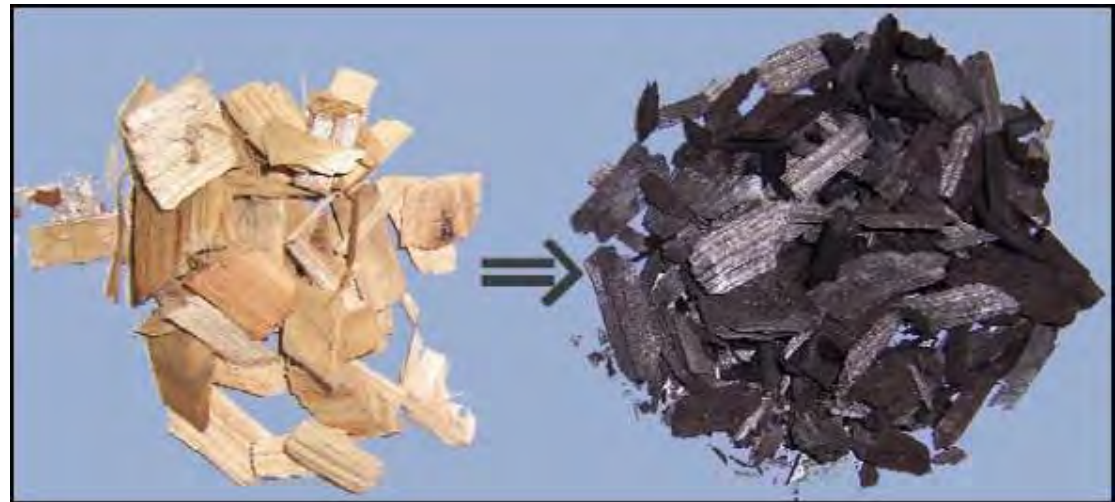

Heat Converts Solids to Gas Leaving Char

Pyro-lysis: from pyro (fire) and lysis (separation)

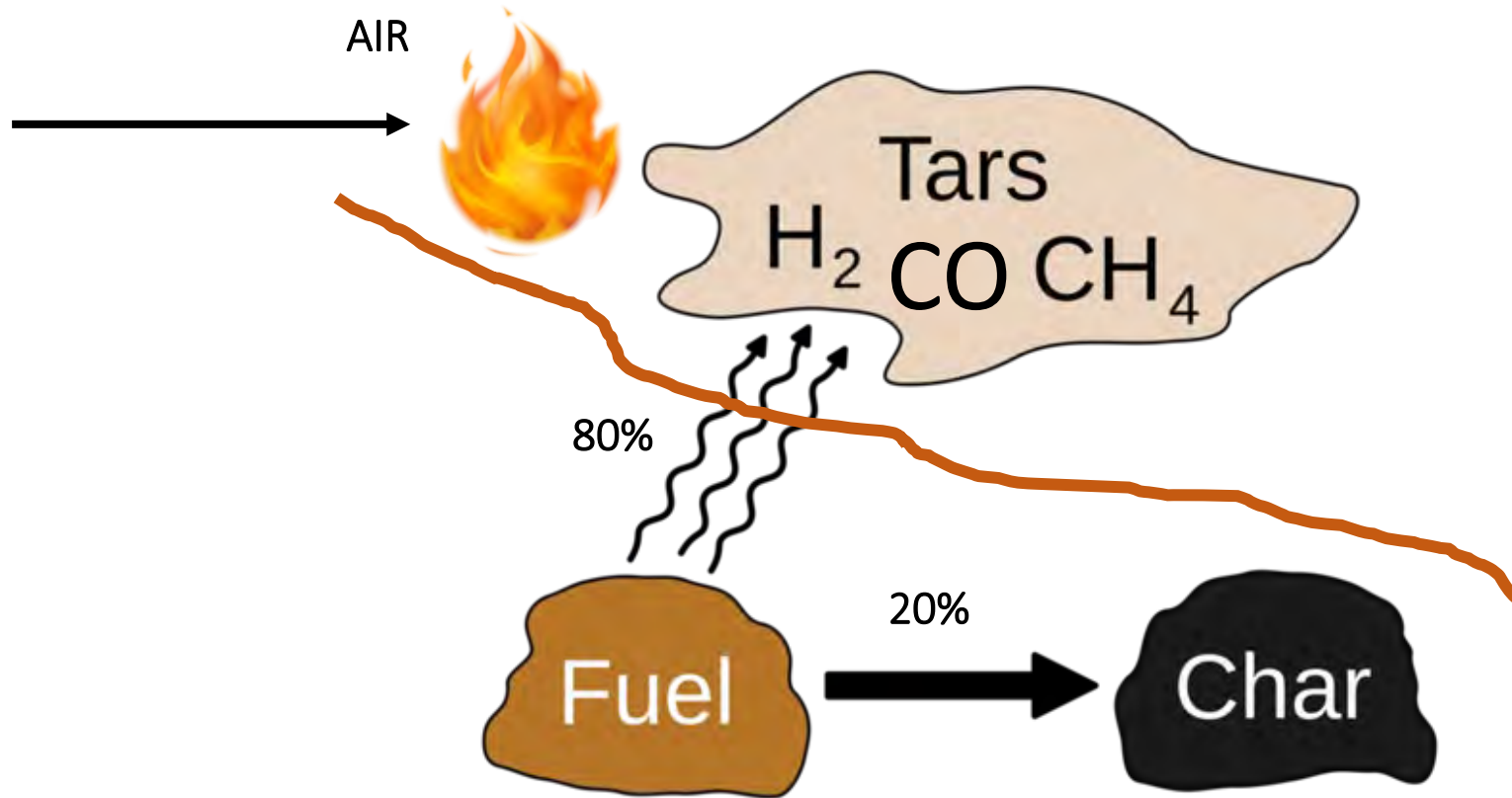

Radiant flames heat solid wood to make gas and char.



Wilsonbiochar.com

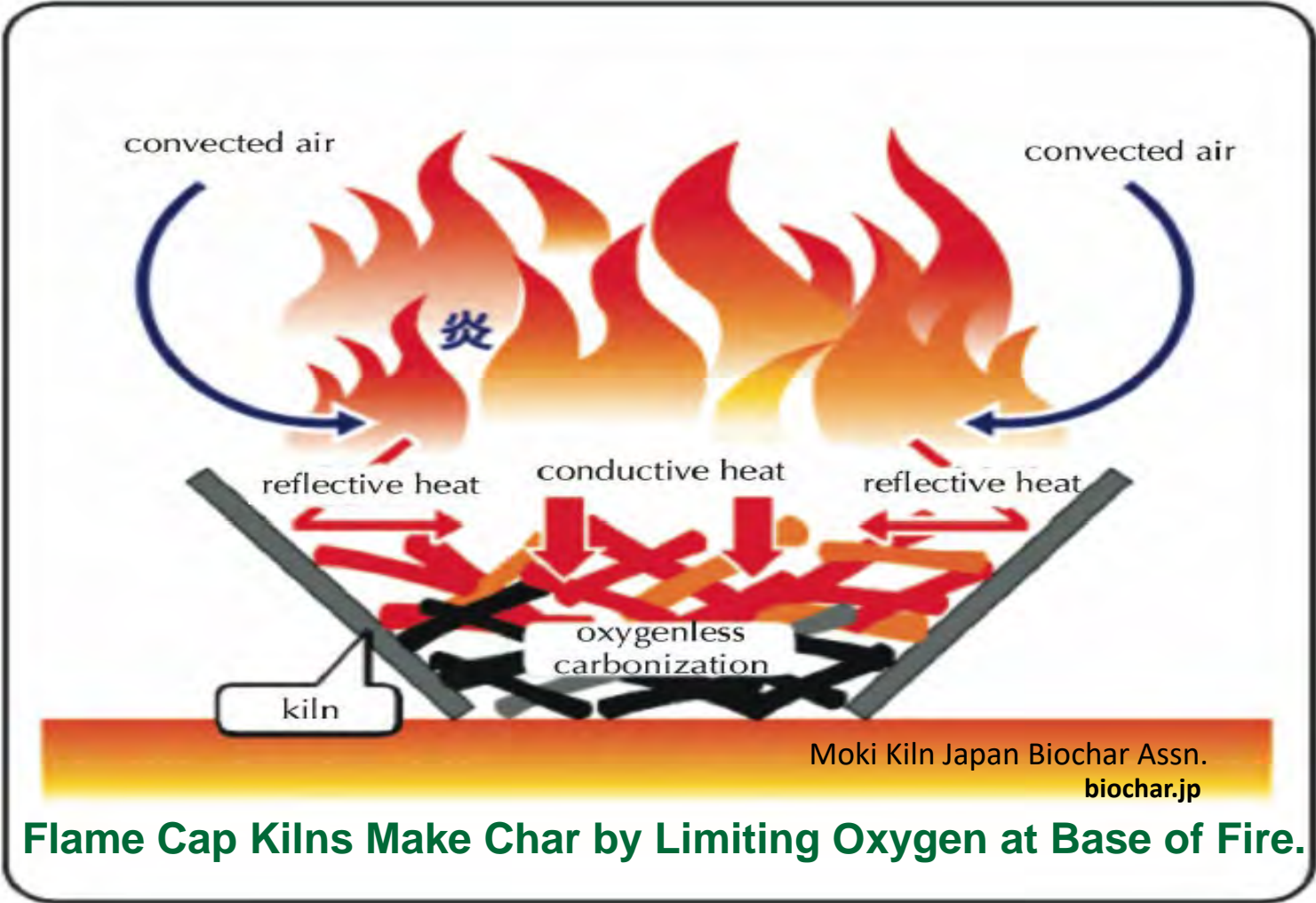

Flame Cap Kilns Make Char by Limiting Oxygen at Base of Fire.



Biochar properties: Process conditions (Peak temperature)

- As temperature increases
 - Biochar yield decreases
 - Fixed carbon increases
 - Surface area increases
 - Ash content increases

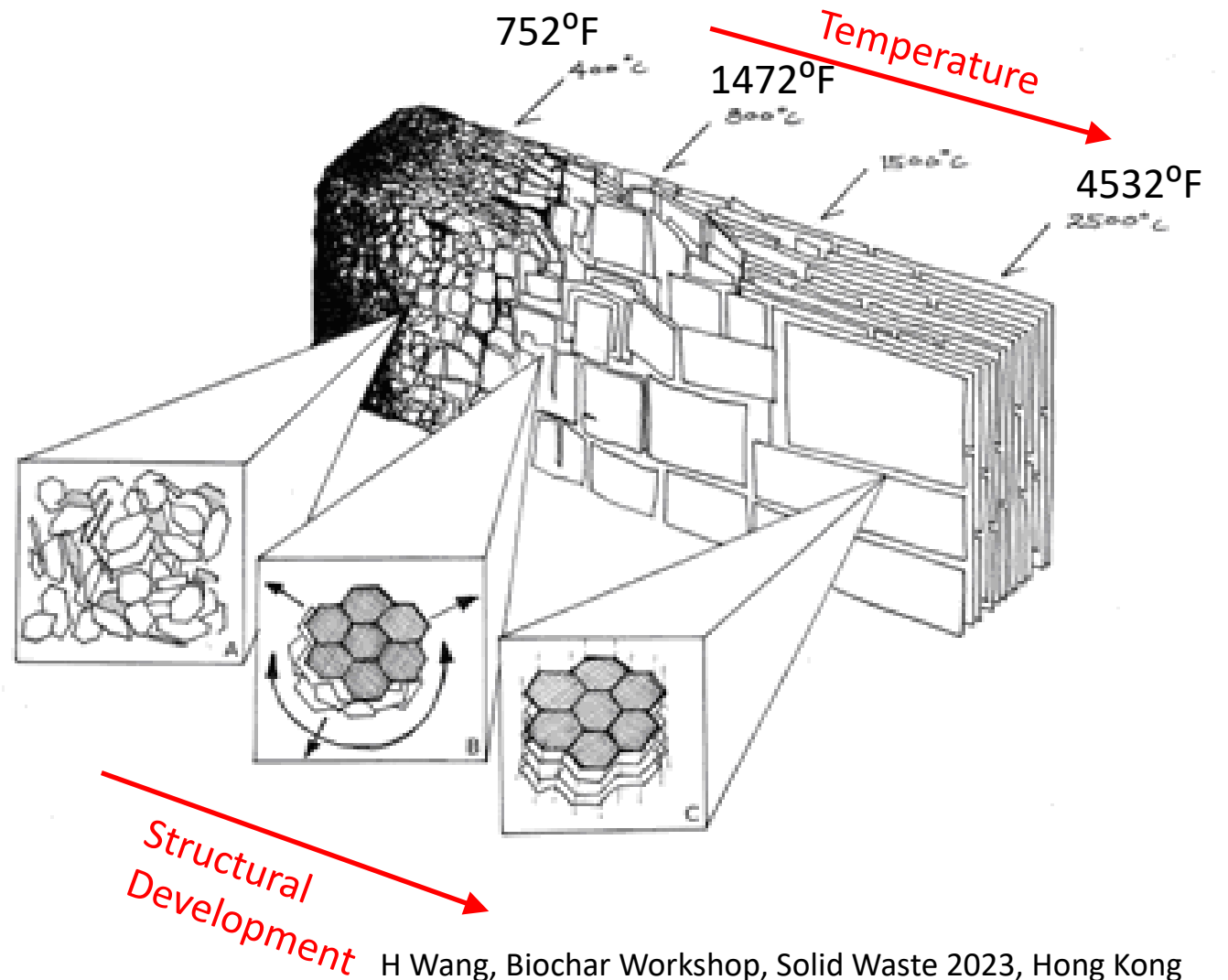

Processes Determine Biochar's Persistence

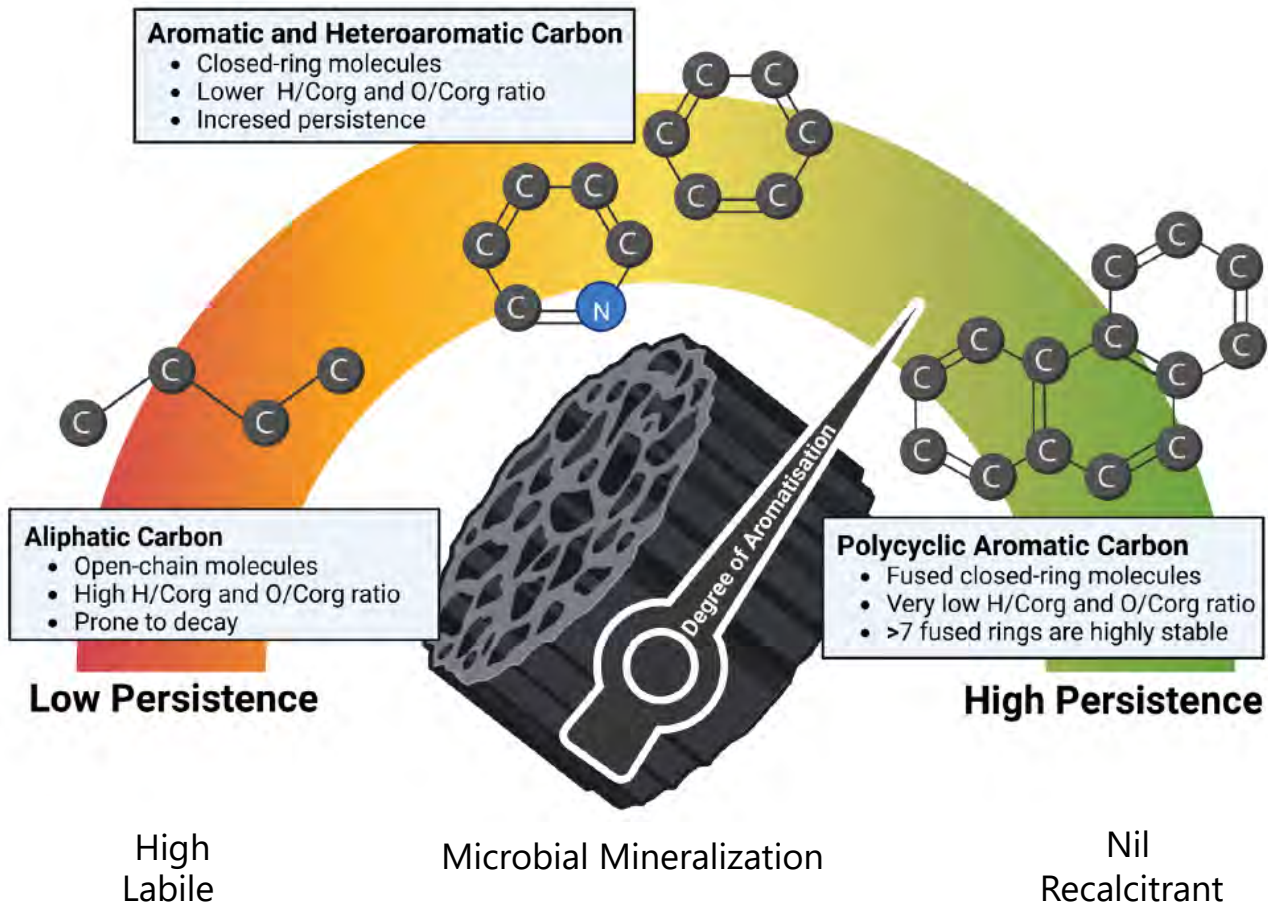

Using Organic geochemistry and petrology methodologies determine that biochar:

- With increasing temp., carbon increase, H/C & O/C decrease
- At 500°C+ 97% TOC is almost infinitely geochemically stable lasting 1000 years or longer
- Limited semi persistent carbon (SPC) has been found to last 50 to 100 years.

(1) Schmidt HP, Abiven S, Hageman N, Meyer zu Drewer J: Permanence of soil applied biochar. An executive summary for Global Biochar Carbon Sink certification, the Biochar Journal 2022, Arbaz, Switzerland, www.biochar-journal.org/en/ct/109, pp 69-74

(2) Peterson, H.I., Lassen, L., Rudra, A., Nguyen, L.X., Do, P.T.M., Sanei, H.: Carbon stability and morphotype composition of biochars from feedstock in the Mekong Delta, Vietnam, International Journal of Coal Geology, April 4, 2023, 104233.



Process Conditions Alter Biochar Properties

To enhance biochar yield:

- Lower temperatures
- Higher pressures
- Longer vapour residence time
- Slower heating rate
- Larger particle size

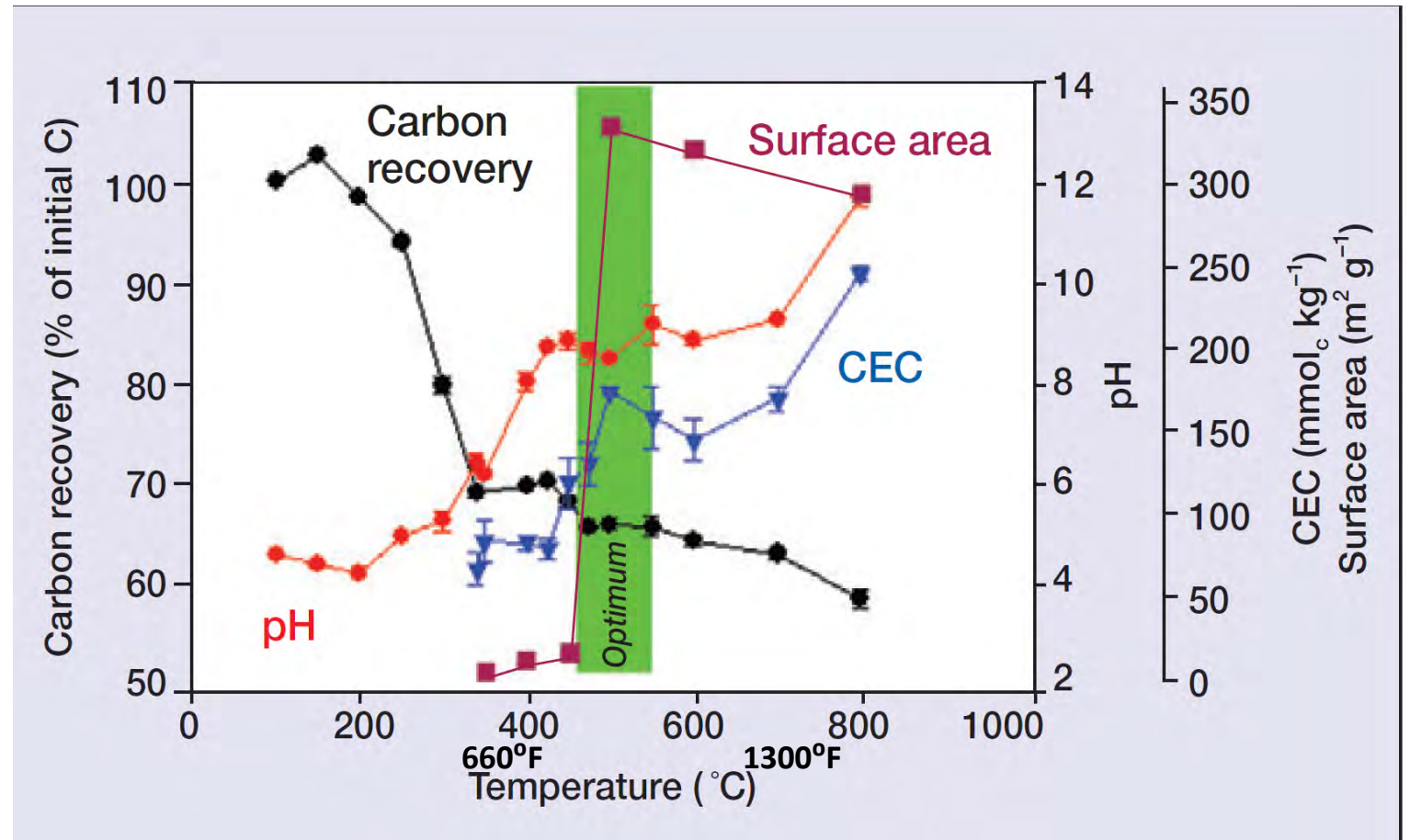

Temperature effects on Black Locust (*Robinia pseudacacia* L)

J. Lehmann *Front Ecol Environ* 2007; 5(7): 381–387

What Biochar Qualities Do You Need?

Biochars are fine-grained, highly porous charcoals that help soils retain nutrients and water. International Biochar Initiative

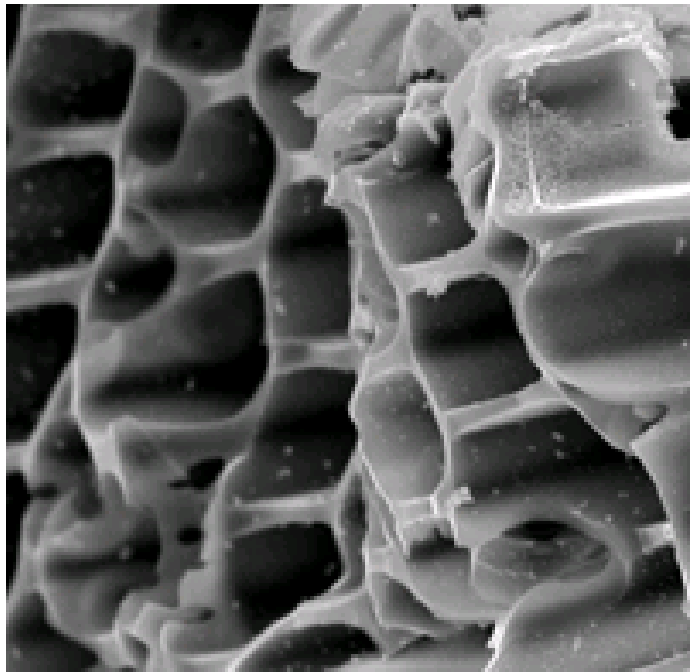

Collins 2009

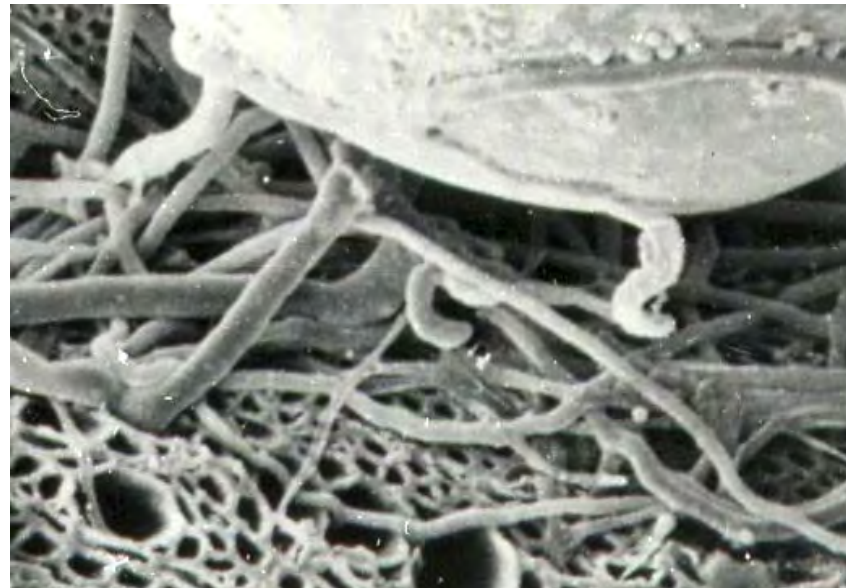

Mycorrhizal fungal hyphae growing from spore base invade large charcoal pores Ogawa 2004

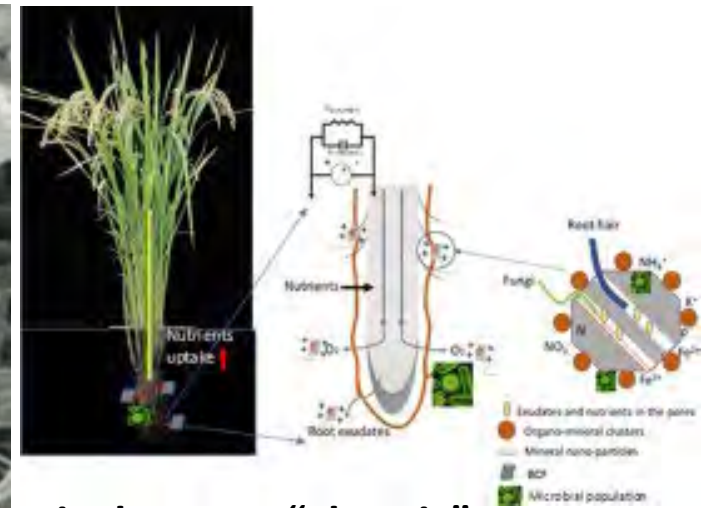

Biochars are “electric”

Biochar-based fertilizer redox potential, eH
Chew et al. 2020 bit.ly/30TQnIB

Biochar Physical Properties

Highly porous; surface area up to 500 m²/g

Three distinct pore types:

External pores: Dependent on particle size

Macropores: Dependent on feedstock

- 10-100 μm range for wood biochars

Micropores: Dependent on production

- 1-10 nm range = 10-100 water molecules!
- Majority of surface area with high potential sorption

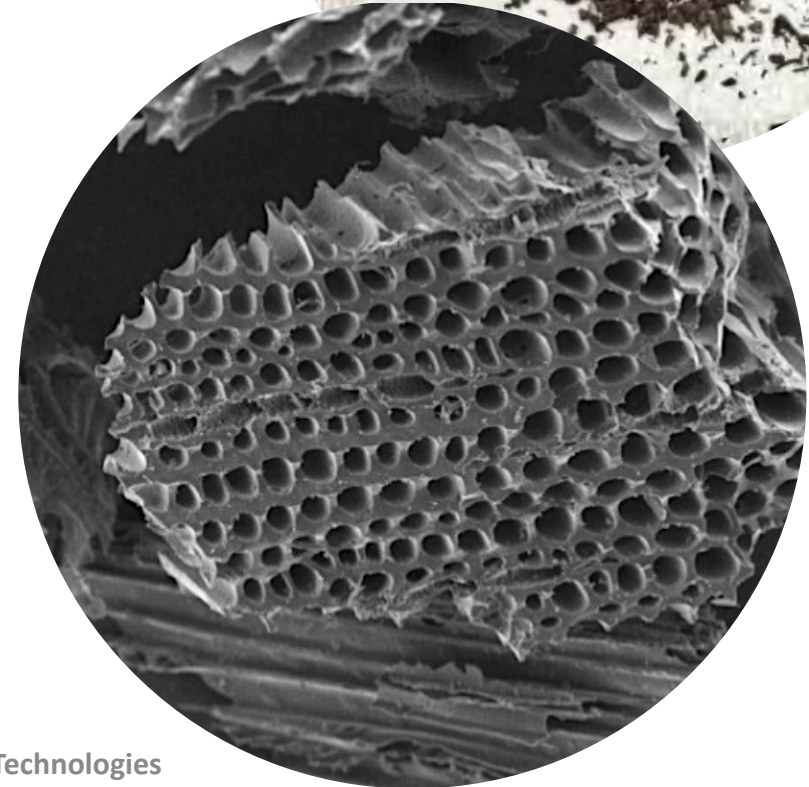

Myles Gray

Biochars Can Have Different Properties

Properties depend on feedstock and production process



Douglas-fir 500 °C

Douglas-fir 650 °C

Hazelnut shells 500 °C

Hazelnut shells 650 °C

Top Row Scale
100 μm

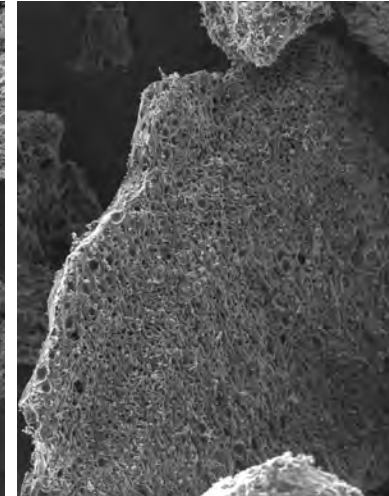
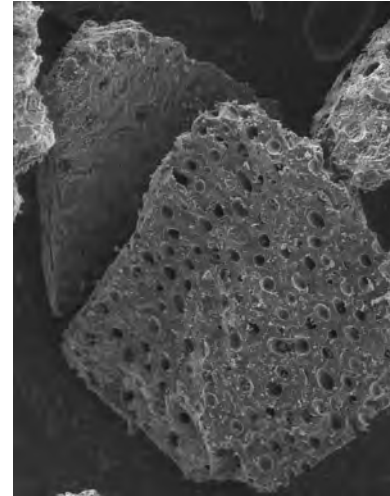
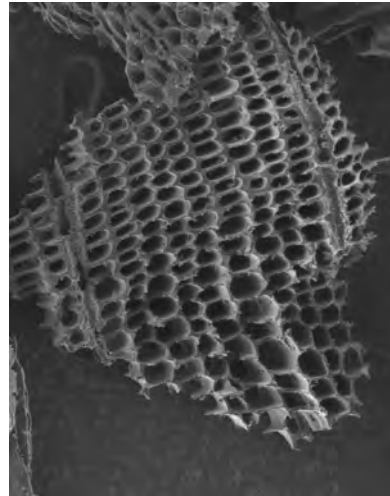
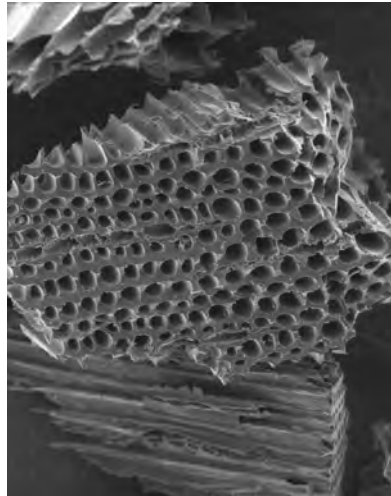

Bottom Row Scale
20 μm

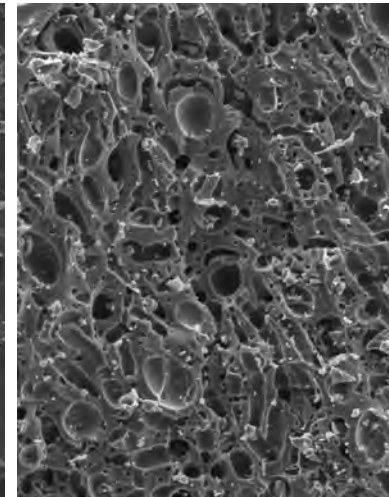
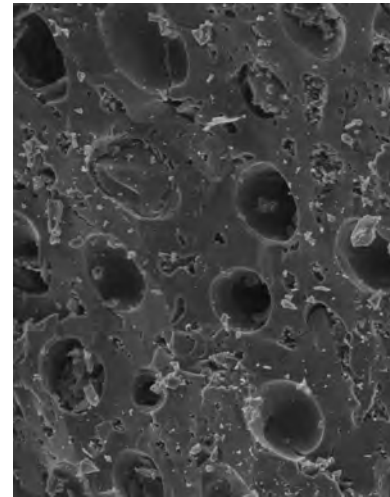
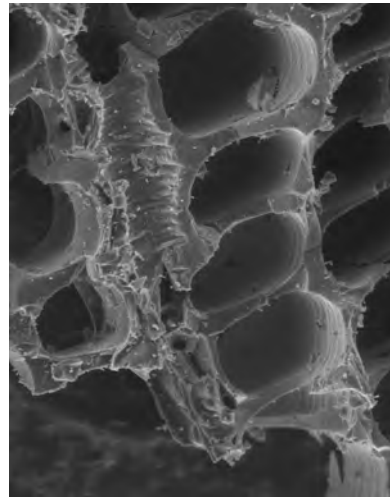
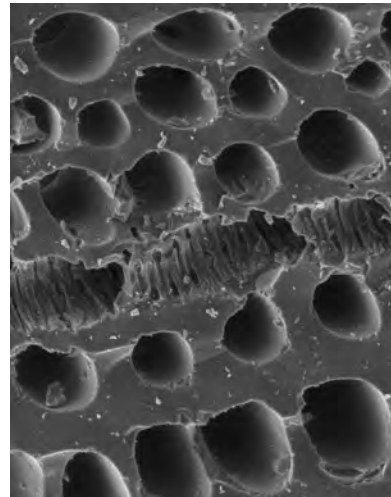

Conceptual scheme for the effects of biochar application on the soil physical, chemical, and microbial properties and greenhouse gas emissions in forest ecosystems

WHC water holding capacity, SOC soil organic carbon, CEC cation exchange capacity

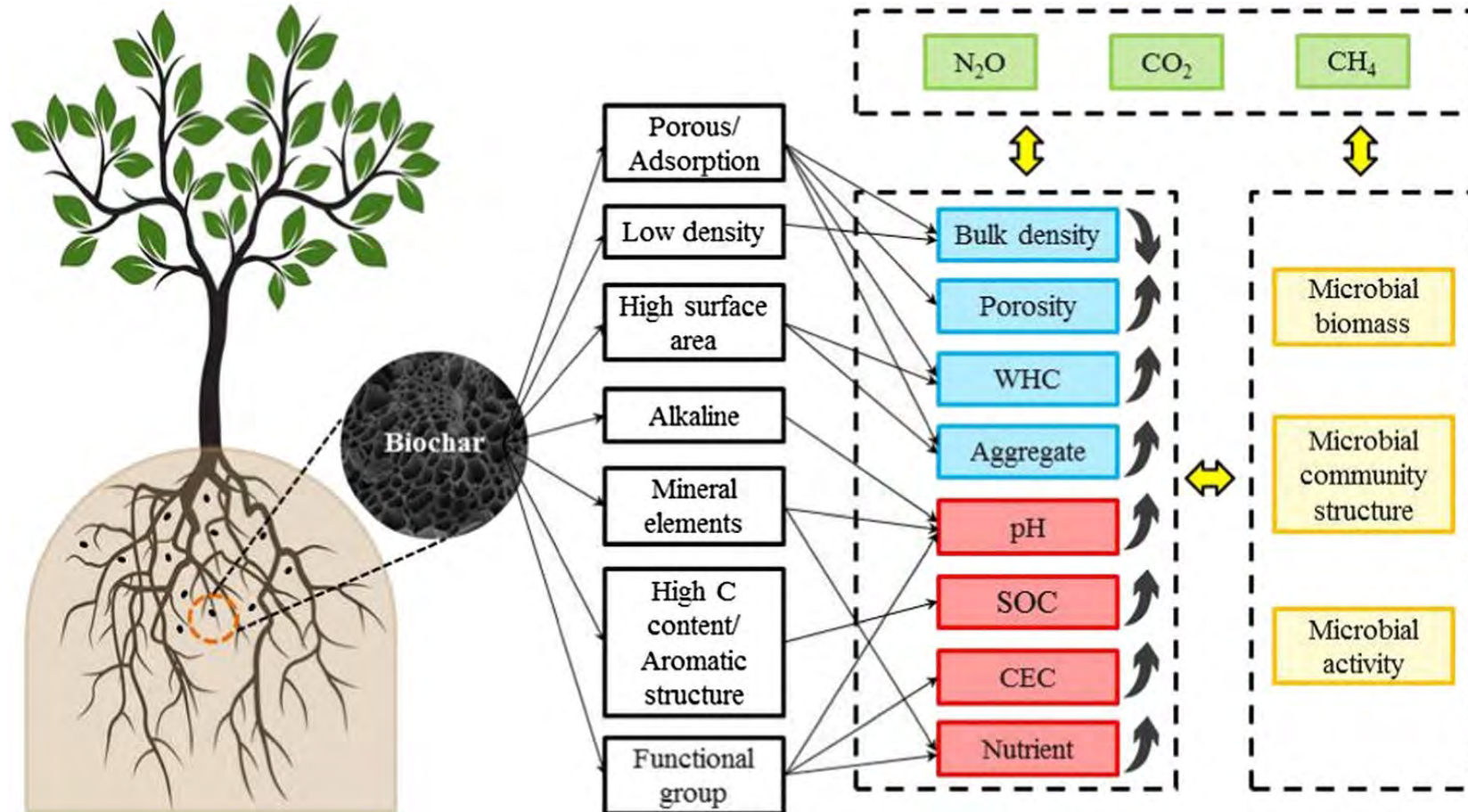

Li et al. 2018. Effects of biochar application in forest ecosystems on soil properties and greenhouse gas emissions: a review. *Journal of Soils and Sediments* 18: 546–563.

Biochar Benefits from 26 Reviewed Meta-Analyses

(Schmidt et al. 2021)

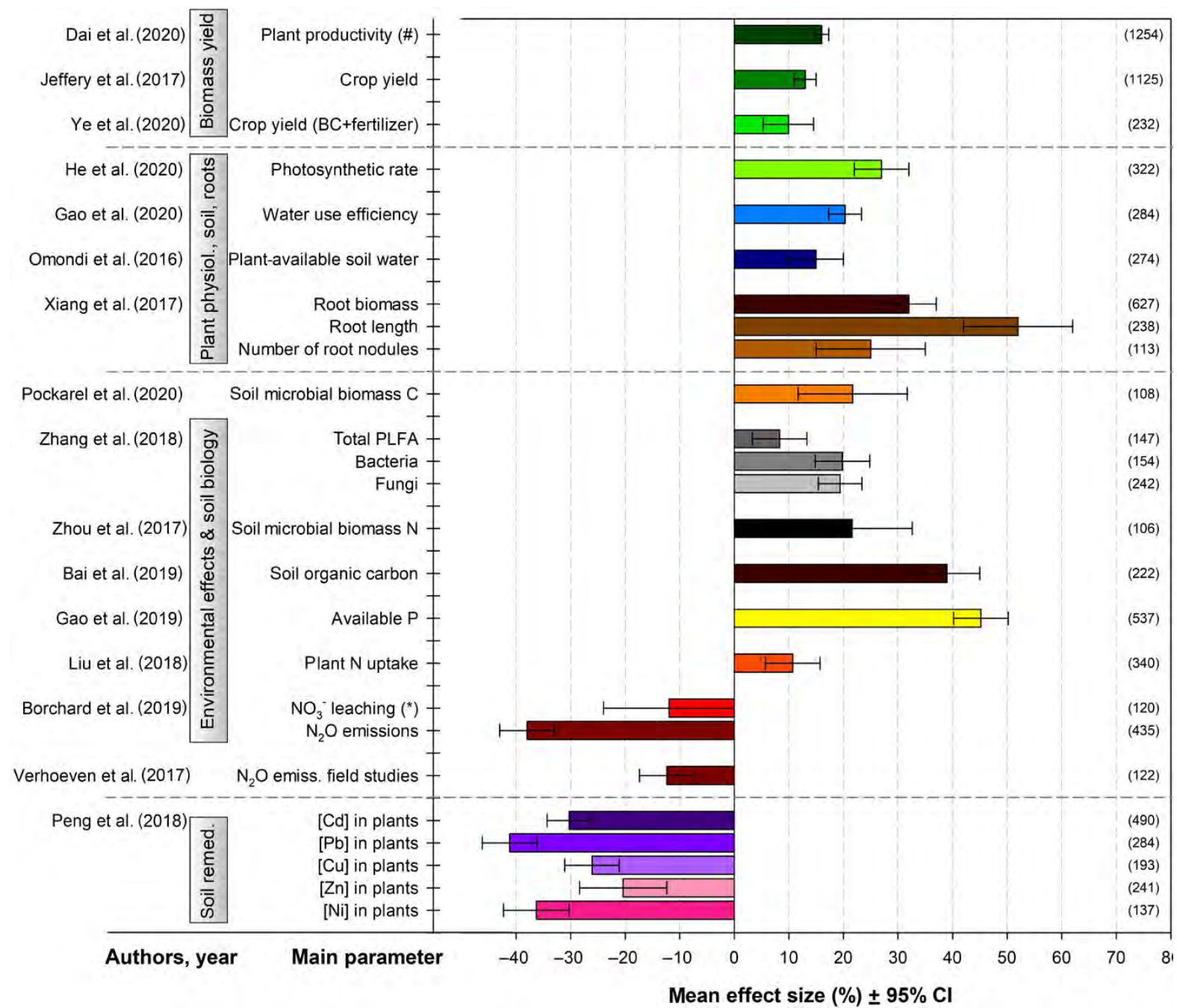

Design Biochars to Fit the Needs

- Increase retention of chemicals, minerals
- Enhance immobilization of contaminants and reduce their bioavailability
- Increase mycorrhizal fungal activity
- Reduce GHG emissions (CH_4 and N_2O)
- Reduce acidity
- Reduce irrigation
-



Biochars Are Made for Different Uses



Soil Health: Agriculture, Retail Garden, Landscape, Turf, Trees, Orchards, Vineyards, Horticulture

Biochar, Compost, Composted biochar (5%-20% biochar)
Animal bedding, litter, feed trials
Biochar-Based Fertilizers (15%-25% biochar)
Biotic Soil Amendments (biochar + organics+ minerals and biologicals)
Granulated and liquid products for seeding, foliar sprays (extracts)
Micro/nano carbons, nanofertilizers



Environment, Remediation, Erosion Control

Revegetation, Biosolids, Urban Soils, Erosion Control, Wetlands, Odor, Waste, Remediation Persistent Herbicides (USCC), PFOS/PFAS



Water quality stormwater filtration, water treatment

- functionalized chars, 3d aerogels, antibiotics



Forestry

Wildfire fuel reduction, Reforestation, Range Improvement
Growing media for nursery and out planting
Revegetation, Reclamation of mines and degraded land



Carbon, Renewable Energy Offsets, and Non-Soil Products

Carbon markets, building products, odor control, batteries



Biochars are Processed for Different Forms and Qualities for Different Uses: Size, Density, Bag, Liquify

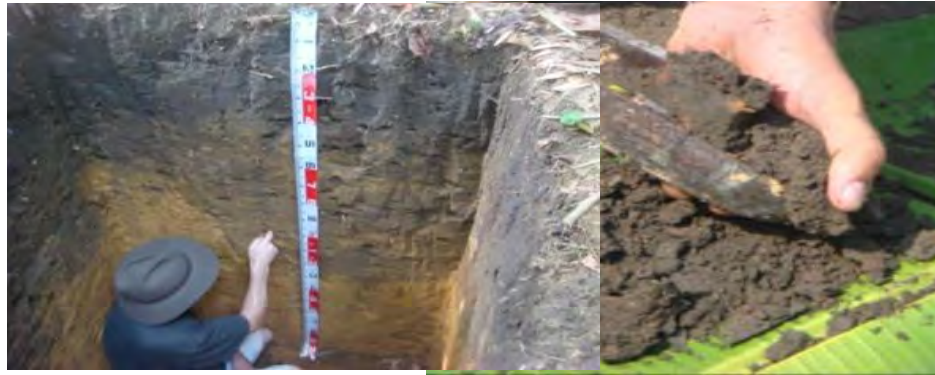

Granulated Biochar Seedballs Aid Aerial Seeding for Green Carbon Cover in Africa, Australia and America



Seedballs Kenya
seedballskenya.com



Airseed Technologies
airseedtech.com

Biochars are Ingredients in Agriculture, Retail Garden, Horticulture, Turf, Tree, and Landscape Applications



Rexius/OpusGrows, US
www.opusgrows.com



Carbon Gold, UK
www.carbongold.com



G&B Organics Eden Valley Blend Potting Soil with **BiocharMax™**
www.kelloggarden.com

Ingredients in Green Frontier Compost

Yard Waste
Food Waste
Biochar*
Loess Clay



Harvest Quest Fungal Inoculant
Azomite Mineral Supplement
Wood Vinegar

***16% biochar by finished volume**

Missouri Organic Recycling
www.missouriorganic.com/compost

Others: America Biochar Company, Biochar Supreme, Sustane Organic + Biochar, Mirimichi Green CarbonizPn Turf Enhancer, Lesco, Wakefield Biochar Soil Conditioner . . .





Adding biochar can enhance the composting process:

- Reduces odor
- Reduces ammonia loss
- Increases nitrogen retention
- Accelerates the composting process
- **Enhances the beneficial biological populations in compost !**



Photo: Chargrow



Biochar + Manure = “Biochar Is A Farmer’s Best Friend” No Smoke. Healthy Crops. Healthy Animals. Happy Farmers.

Sr. Miriam Paulette with biochar from flame cap pit at the Carmelite Monastery in Zomba, Malawi.



Metal cover to quench char.



Training to make biochar in flame cap pit kiln. No smoke.

Kenya: Trainer Everline with bumper sorghum crop.



Biochar + Manure
Everline’s corn with biochar + manure



VS

Her poor harvest with commercial fertilizer.



Warm Heart Worldwide Malawi

warmheartworldwide.org/biochar-africa

Warm Heart Worldwide, Kenya

BiocharLife
An Impact Venture by Warm Heart Worldwide

2021 During pandemic 7500 smallholders trained by other biochar users.



Animals Inoculate, Distribute, and Mix Biochars in Soil, Improve Forage, Animal Health, Soil Health



- Deer, elk, cattle, pigs, chickens, goats, sheep feed on char which improves health and increases egg, milk, and meat production. Enriched biochar is passed out in the dung.
- Dung Beetles mix and inoculate biochars into soil, improving forage quality and production.
- Worms ingest biochar to form inoculated micro and nanocarbons



Photo: Sr. Miriam Paulette



Photo: Kathy Dawson

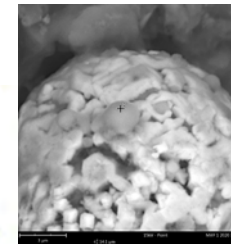

Photo: Stephen Joseph

Analyze Biochar Quality

Comply with Environmental and Soil Requirements

Date Received: 12/8/2022
 Sample ID: SOFTWOOD BIOCHAR 01
 Lab ID. Number: XXXXX-01

Physical

General Properties	Result	Units	Method
Moisture (as received)	65.5	% wet wt.	A
Bulk Density	6.6	lb/cu ft (dry)	
Organic Carbon	87.5	%	B
Hydrogen/Carbon (H:Corg)	0.21	Molar Ratio	B
pH value	8.87	units	C
Electrical Conductivity	0.985	dS/m	C
Liming (as-CaCO3)	7.3	% CaCO3	I
Carbonates (as-CaCO3)	2.2	% CaCO3	J
Butane Act.	10.0	g/100g dry	G
Surface Area Correlation	451	m ² /g	G

Chemical

Particle Size Distribution	Result	Units	Method
< 0.5 mm	13.1	%	F
0.5 - 1 mm	17.4	%	F
1 - 2 mm	32.9	%	F
2 - 4 mm	34.5	%	F
4 - 8 mm	2.0	%	F
8 - 16 mm	0.0	%	F
16 - 25 mm	0.0	%	F
25 - 50 mm	0.0	%	F
> 50 mm	0.0	%	F

Environmental

Primary Nutrients	Result	Units	Method
Nitrogen N	0.72	%	E
Phosphorus P	0.07	%	E
Potassium K	0.74	%	B

Secondary Nutrients	Result	Units	Method
Calcium Ca	7410	mg/kg	E
Magnesium Mg	972	mg/kg	E
Sulfur S	211	mg/kg	E

Proximate Analysis	Result	Units	Method
Carbon C	87.8	%	B
Hydrogen H	1.56	%	B
Nitrogen N	0.72	%	B
Sulfur S	0.02	%	E
Oxygen O	5.3	%	Calc
Ash	4.6	%	A
	100.0	% Total	

EPA 503 Metals	Result	Units	MRL	Method
Arsenic As	0.62	mg/kg	0.45	H
Cadmium Cd	ND	mg/kg	0.18	H
Chromium Cr	39.9	mg/kg	0.45	H
Cobalt Co	1.4	mg/kg	0.45	H
Lead Pb	0.83	mg/kg	0.18	H
Mercury Hg	ND	mg/kg	0.001	K
Molybdenum Mo	0.48	mg/kg	0.45	H
Nickel Ni	19.9	mg/kg	0.45	H
Selenium Se	ND	mg/kg	0.90	H
Zinc Zn	13.6	mg/kg	0.90	H

Other Elements	Result	Units	MRL	Method
Sodium Na	553	mg/kg	451	E
Chlorine Cl	442	mg/kg	20	D
Aluminum Al	901	mg/kg	45.1	E

Trace Nutrients	Result	Units	MRL	Method
Copper Cu	7.8	mg/kg	0.45	H
Zinc Zn	13.6	mg/kg	0.90	H
Iron Fe	1307	mg/kg	22.5	E
Manganese Mn	190	mg/kg	0.45	H
Boron B	18.9	mg/kg	4.5	H

* "ND" stands for "not detected" which means the result is below the Method Reporting Limit (MRL).

Method A ASTM D1762-84
 B Dry Combustion - LECO
 C TMECC (2001) 4.10 & 4.11, 1:20 dilution
 D 1:20 dilution, Ion Chromatography
 E EPA3050B/EPA 6010
 F ASTM D 2862 Granular

G Surface area correlation based on 'Analytical Options for Biochar Adsorption...' (McLaughlin et al, 2012)
 H EPA3050B/EPA 6020
 I AOAC 955.01
 J ASTM D 4373
 K EPA 7471

Analyst: XXXX

Pacific Biochar

USBI Factsheet:

Interpreting Biochar Analysis

Coming Soon!



Biochar Qualities Help Determine Appropriate Use

Carbon Storage Class

H/C_{org}

C_{org} % total mass, dry basis

Fertilizer Class

Total N	%	<input type="text" value="3.77"/>	mass basis	Avail. N	%	<input type="text" value="0.19"/>	mass basis
Total P	%	<input type="text" value="3.32"/>	mass basis	Avail. P	%	<input type="text" value="2.65"/>	mass basis
Total K	%	<input type="text" value="3.35"/>	mass basis	Avail. K	%	<input type="text" value="3.35"/>	mass basis
Total S	%	<input type="text" value="0.48"/>	mass basis	Avail. S	%	<input type="text" value="0.36"/>	mass basis
Total Mg	%	<input type="text" value="0.9"/>	mass basis	Avail. Mg	%	<input type="text" value="0.86"/>	mass basis
Total Ca	%	<input type="text" value="6.36"/>	mass basis	Avail. Ca	%	<input type="text" value="6.3"/>	mass basis

Liming Class

CaCO₃ % equivalent

Particle Size Class

<0.5mm	%	<input type="text" value="42"/>	2 - <4mm	%	<input type="text" value="6"/>	16 - <25mm	%	<input type="text" value="0"/>
0.6 - <1mm	%	<input type="text" value="30"/>	4 - <8mm	%	<input type="text" value="1"/>	26 - <50mm	%	<input type="text" value="0"/>
1 - <2mm	%	<input type="text" value="21"/>	8 - <16mm	%	<input type="text" value="0"/>	≥50mm	%	<input type="text" value="0"/>

[Show Classification](#)

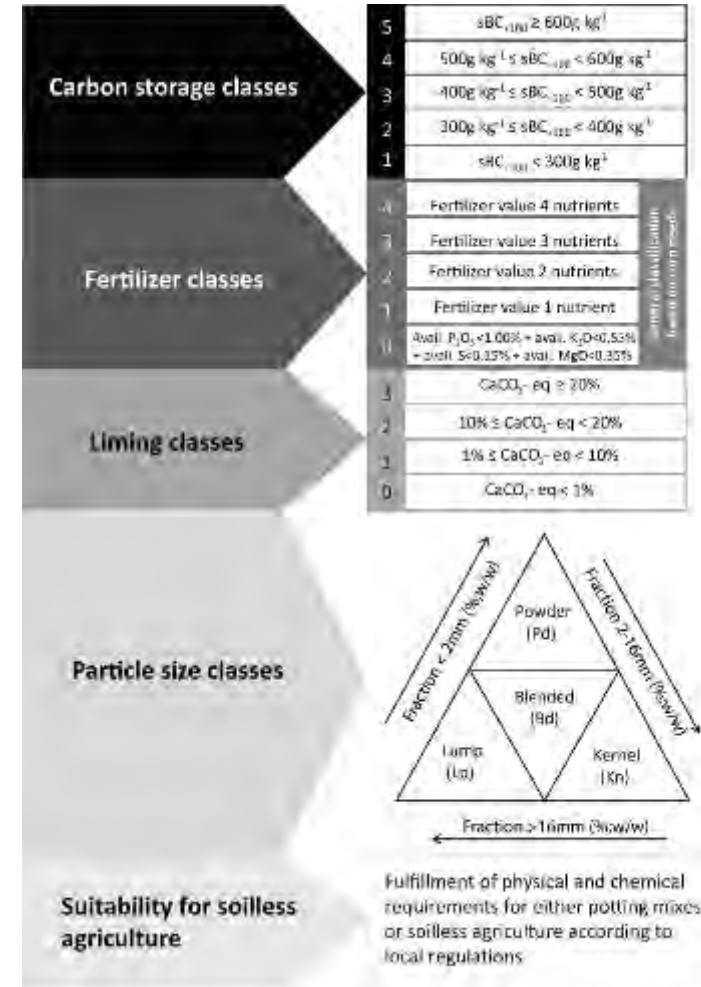

IBI Classification Tool <https://biochar-international.org/resources/biochar-classification-tool/ibi-biochar-classification-tool-main-page/>

Standards, Guidelines, Specifications, Certifications

IBI Certification

Safe for use in soil - Non toxic

Stable (Carbon enriched for lost C)

≥10%, ≥30%, ≥60% Carbon

H:C ratio <0.7 (stability)

Sustainable Carbon smart

European Biochar Standards, Certificate (2015)

World Biochar Certificate (2023)

(Basis for carbon dioxide removal credits, feeding biochar, soil and non soil uses)

Australia New Zealand Biochar Industry Group (ANZBIG)

AAPFCO Association of American Plant Food Control Officials

biochar definition (2016)

OMRI Organic Materials Review Institute

International Biochar Initiative

Std. Ver 2.0

Biochar-international.org



Biochars are Produced in Mobile, Modular, and Industrial Systems



“Ring of Fire”
Wilsonbiochar.com



Carbonator 6050
tigercat.com



ARTIchar
artichar.com



Pyreg 500-6000
Pyreg.de



CharBoss
airburners.com



Biomacon
Biomacon.com



ICM Inc
icminc.com

Place Based Biochar: Simple Kilns for Hand Piles

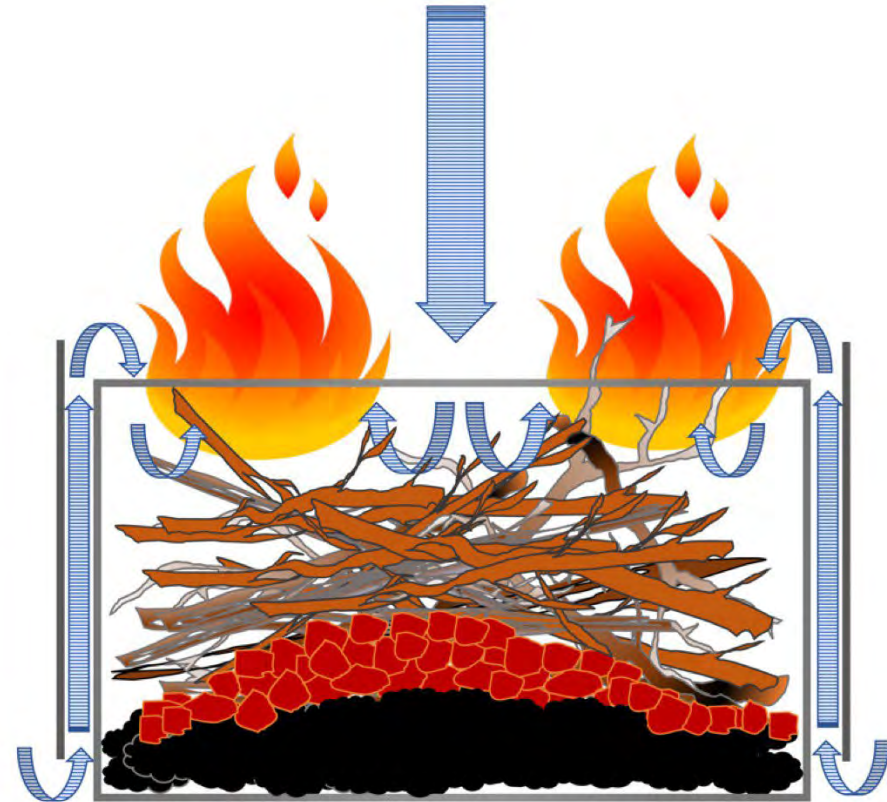
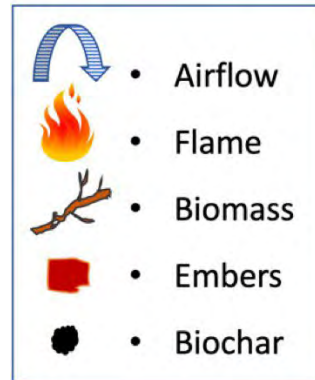

Wood 5.6 CY/kiln
2 CY biochar in 4-5 hours
1-2 people

wilsonbiochar.com

Ring of Fire Kiln®

Place Based Biochar: Portable High Efficiency Kilns



STANDARD" Model:

- Height 4ft 2in
- Volume Top rim 35 ft³
- Filled with char 30 ft³
- Weight empty 1400 lb

1-3 CY/Day

Air assist

Flood quench

Nutrient Rich liquid



KON TIKI TAS

Terra Preta Developments

Tasmania Australia

www.terrapretadevelopments.com.au

Place Based Biochar: Curtain of air burns gases. Biochar withdrawn continuously through a grate.



Air Burners Inc.- USFS Cooperative Research and Development Agreement

Prototype – 1 ton (10-20CY) per hour IN

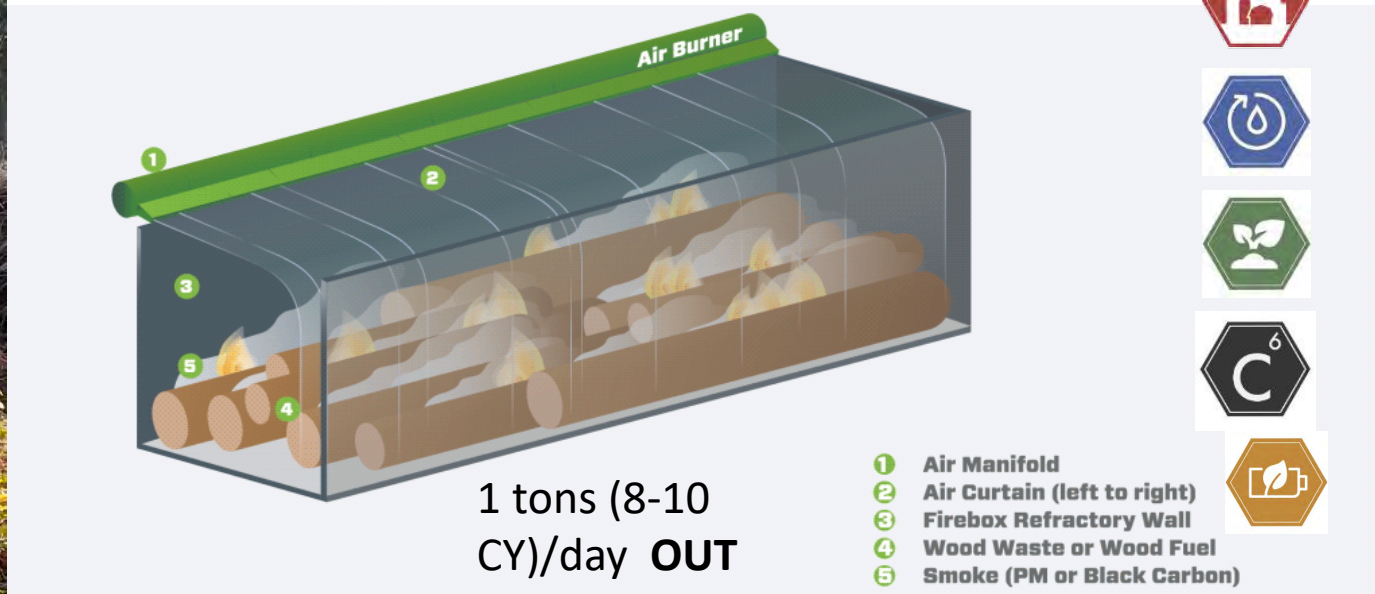

airburners.com



7 CY Chamber
4' x 4' x 12'

Placed Based Biochar: Air Curtain Burners

Recover Biochar and Energy



8 tons biomass/hr 80 t/day
2-4 ton/day biochar (16 CY)



airburners.com



Air Curtain Burner
100-1000 kWe

airburners.com



Mobile Carbonizers Recover Biochar from Forest Fuels and Urban Wood: Biochar Shipped in Bag or Bulk



www.tigercat.com

**Biochar Recovered From Wildfire Debris
Oregon 2020**

Convert forest residues, land clearing wood to biochar for direct use on site or export.



FORESTERS CAN ALSO REMOVE FOREST FUELS USING PORTABLE WOOD GRINDING EQUIPMENT. THESE PRODUCE WOOD CHIPS THAT CAN BE LOADED INTO CHIP VANS FOR TRANSPORT TO NEARBY BIOMASS POWERPLANTS, WHERE THEY ARE CONVERTED INTO ENERGY AND BIOCHAR.



FORESTS AND BIOCHAR
Excess forest fuels can create energy and help build healthy soils



USBI
Building the future from the ground up.™

LEARN MORE AT
www.biochar-us.org

Small Scale Gasifiers: Combined Heat and Biochar



Phoenix Energy
 California
 2 MWe +
 600 lb/hr Biochar 2CY/h
 Eqtec.com gasifier
phoenixenergy.net



Qualterraag.com
 Molecular Plant Testing
 Clean Plant Propagation
 Biomass Processing &
 Carbon Regeneration

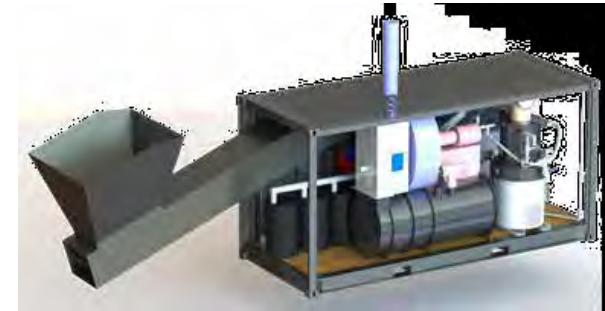

All Power Labs
 Chartainer 150 kWe+biochar
 (Under development)
www.allpowerlabs.com



Charpallet 25

Biomass: 55 lb/hr
 Biochar: 11 lb/hr
 Heat: 170,000 Btuh
 Operation: ~12 hours
 Start-Up Time: 20 – 40min



Turn Biomass into Electricity

Small Stationary Systems: Small Scale Gasification

Low Capacity

- 600-1200 lb/hr feedstock
- 150-300 lb/hr biochar
- 0.5-1 CY/hr

Simple Operation

- Automated control

Heat Recovery

- Hot air or hot water



Integrated Modular Pyrolysis Systems: Heat and Biochar

– BET, ARTiChar



BET

biomassenergytechniques.com



5-train

BIOCHAR PRODUCTION UNIT



PYROLYZES
40 TONS
of BIOMASS PER DAY



PRODUCES
10 TONS
of BIOCHAR PER DAY



SEQUESTERS
20 TONS
of CO₂eq. PER DAY



ARTi.com

Small to Medium Scale European Systems

Examples for industrial equipment producing Biochar



Biomacon

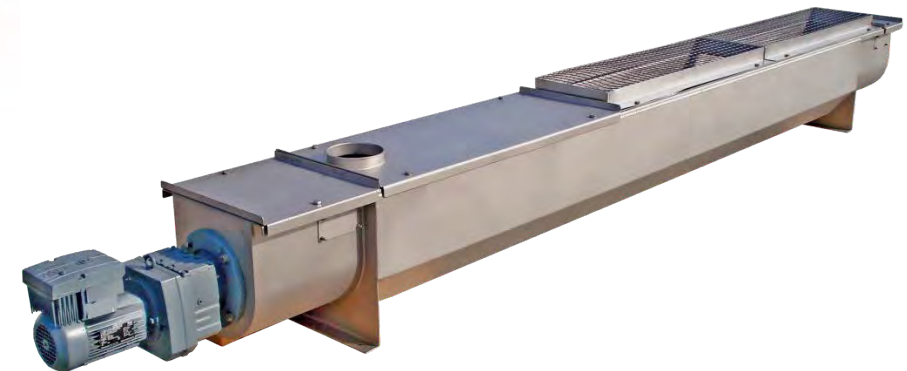

biochar-industry.com



Biochar Boilers: Combined Heat and Biochar

Auen Pflege Dienst – Flaach



Reference Project (“Small”)



- Customer: **Auen Pflege Dienst AG (CH)**
- Equipment: **Biomacon C400-I**
- Commissioning: **2019**
- Feedstock: **Natural wood (forest and landscape management)**
- Energy utilization: **Feeding up to 400 kWth into the local district heating network and an own district heating network for industry**
- Biochar production: up to **360 t/yr of Biochar**

biochar-industry.com

Small Scale Combined Heat and Biochar



Biomacon.com

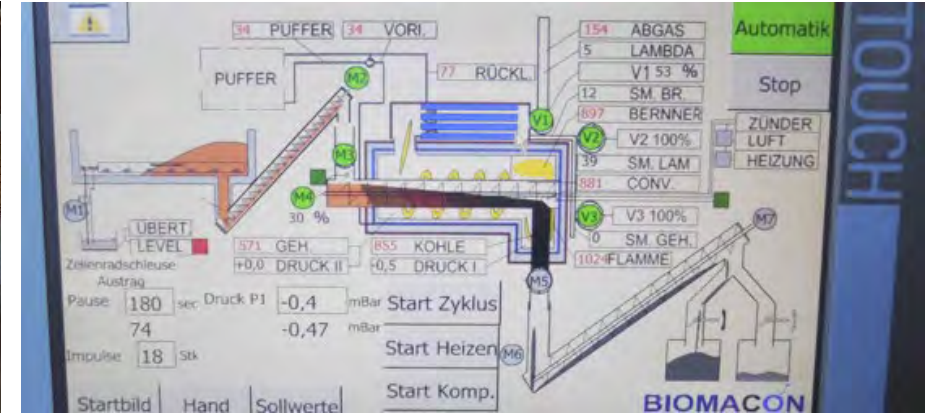
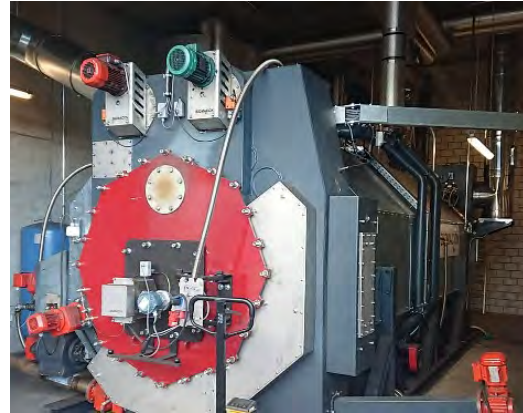

1.7 MMBtuh (500 KW) + 100 lb/hr biochar



Char used in structured soil

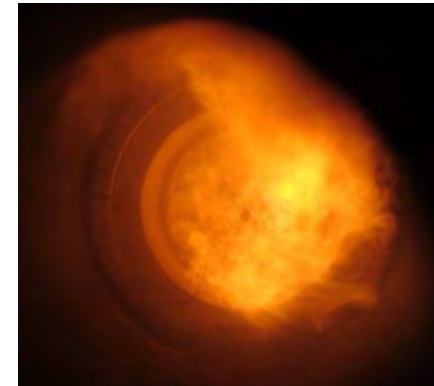

Gasifier-Boiler 4 MMBtuh (1200 kW) + 125 lb/hr biochar

Pyrolyze Chipped Wood to Heat, Biochar, and Oil

– VOW ASA/Biogreen Energy

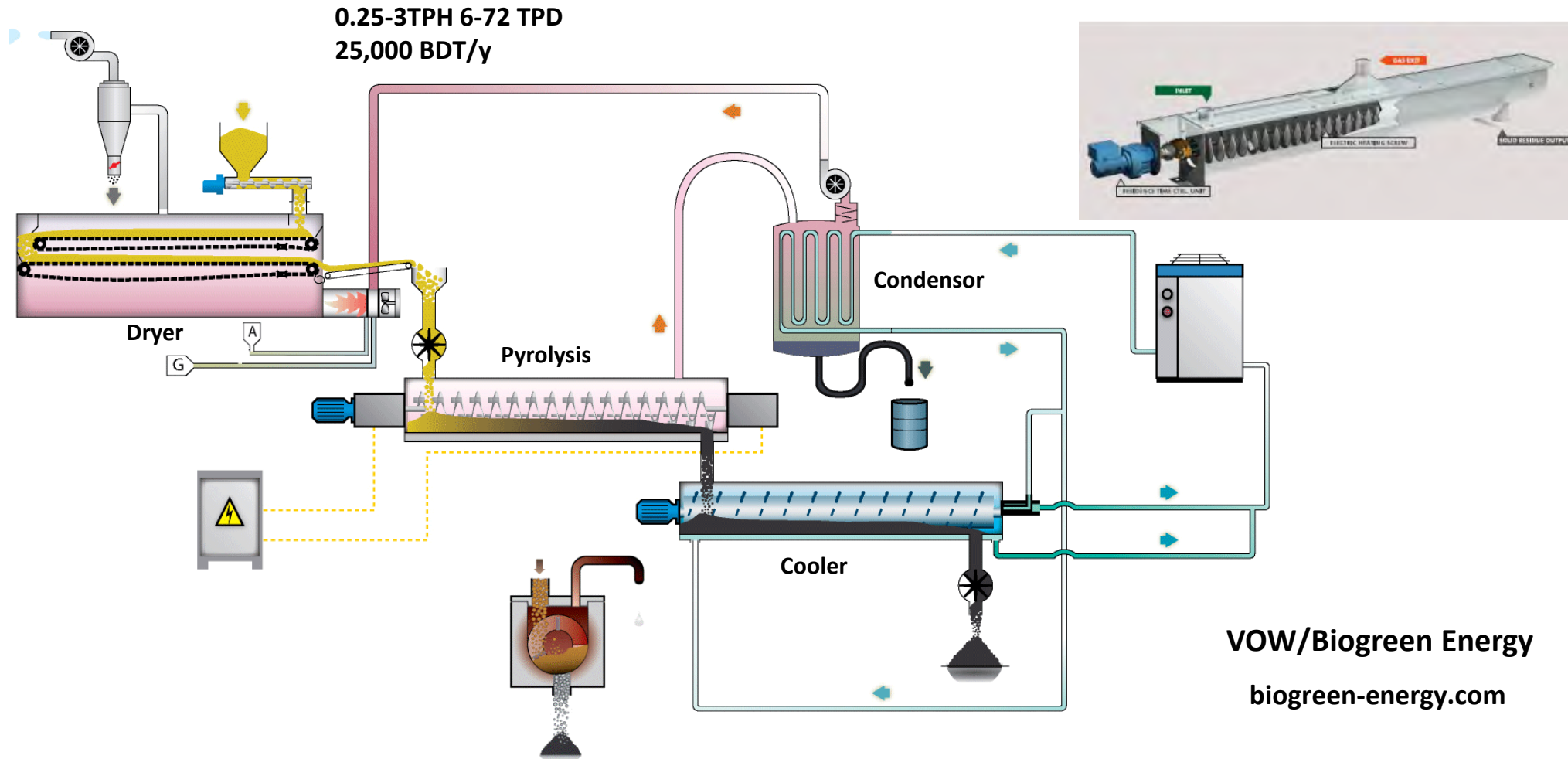

Small Industrial Gasifiers Produce Heat and Biochar



Earthcare LLC

earthcarellc.com

2 tph fuel 50 TPD

12 tpd Biochar

Wood, Manure, Litters, Gasification, Heat



Ecoremedy

Fluid Lift Gasification

ecoremedyllc.com

Wood, Manure, Digestate, Biosolids,
Heat



Greenhouse Heating + Biochar (for Compost)



www.rainbowbeeater.com.au

Green Sawdust Gasifier Chars Enhance Turf and Trees



KDS Systems Green Sawdust Gasifier heats Lumber Dry Kilns www.kdskilns.com
3-5 tph fuel input, .25-0.4 t/hr biochar

Biochar co-product refined for landscaping



Liquid or granular biotic soil amendment for golf and turf (LESCO CarbonPro lesco.com)



CarbonPro
www.lesco.com/products/carbonpro

Deeper stronger roots
Improved greening
Improved Soil and Seed Establishment
Increased Nutrient Uptake and Efficiency
Reduced Water Requirements
Targeted Benefits

Rotary Kiln Heats Biomass in Rotating Drum Using Pyrolysis or Auxiliary Gas 48-144 t/d

INDIRECT-FIRED ROTARY KILN

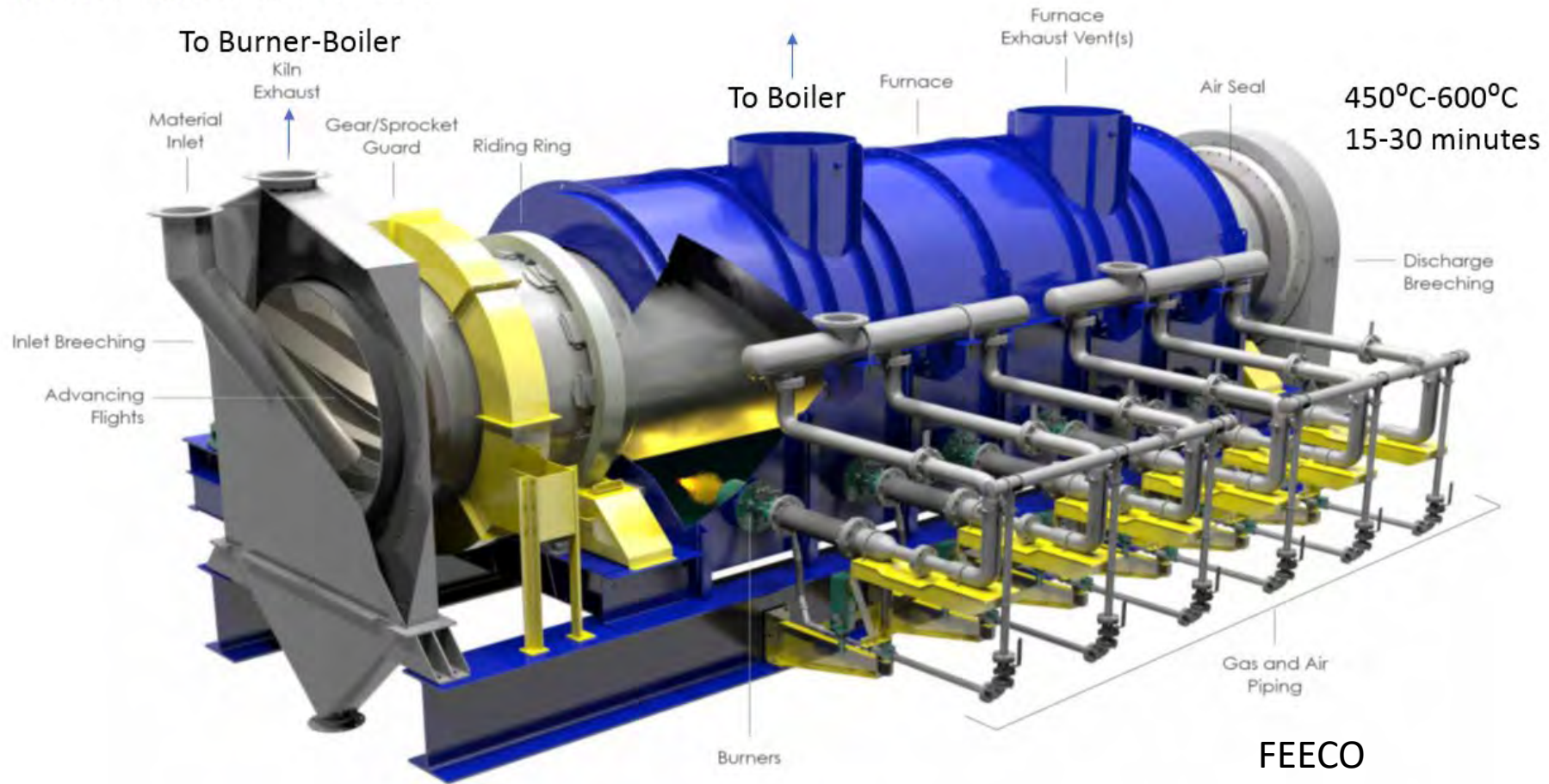

FEECO
Feeco.com

Rotary Kiln Pyrolysis 48-144 t/d



Char Technologies
chartechnologies.com



Sanju Crop Residue to Biochar Fertilizer Production Facility
2.5 mt/hr, gas+pyrogas



Combined Heat, Power and Biochar



biochar-industry.com



Large Scale Projects: Myno Carbon

Washington:

Biochar Carbon Dioxide Credits Generated in EV Fuel Production

Myno Carbon mynocarbon.com



SUSTAINABLY SOURCED FOREST AND AGRICULTURE WASTE BIOMASS
~183,000 DRY TONS PER YEAR

GRINDING



DRYING



GASIFIER



STEAM BOILER



PRODUCER GASES

WASTE HEAT

CARBON REMOVAL CREDITS
~90,000 MT CO2E REMOVED PER YEAR VIA 40,000 TONS ANNUAL BIOCHAR PRODUCTION



CARBON AVOIDANCE CREDITS
~200,000 MT CO2E ANNUAL EMISSIONS REDUCTION VIA NOT BURNING SLASH, LESS FEEDSTOCK ROTTING

GREEN STEAM

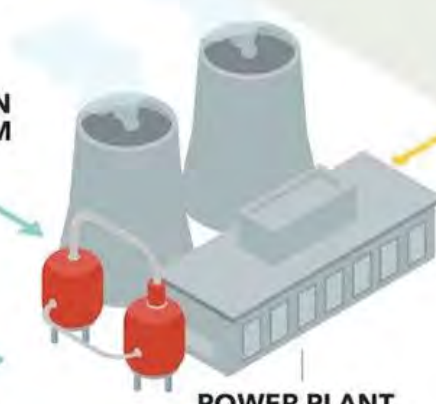

CARBON-NEGATIVE ELECTRICITY
~18 MW RENEWABLE BASELOAD POWER

Wood Gasifier: Biochar, Steam and Power (7 MWe)



Waste Wood Heats Kansas Ethanol Plant ICMinc.com



Biochar From Staged Combustion: KMW

Operational Changes - Heating vs Producing Biochar



Combined Heat and Biochar Operation

Steam Boilers 200-2500 BHP
Hot Water Boiler 100-1500 BHP

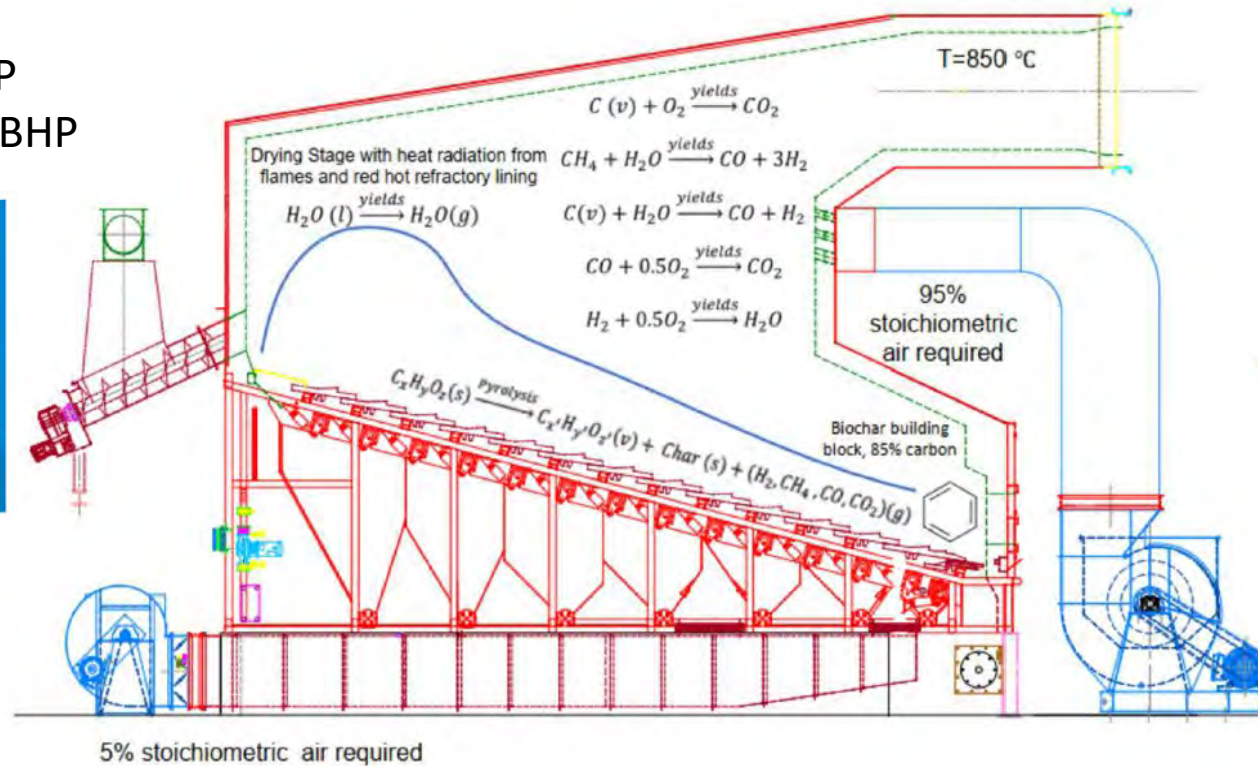

www.kmwenergy.com

Combined Heat and Biochar: KMW



Biochar Systems - Heat and Mass Balance

Heating only Operating Mode:

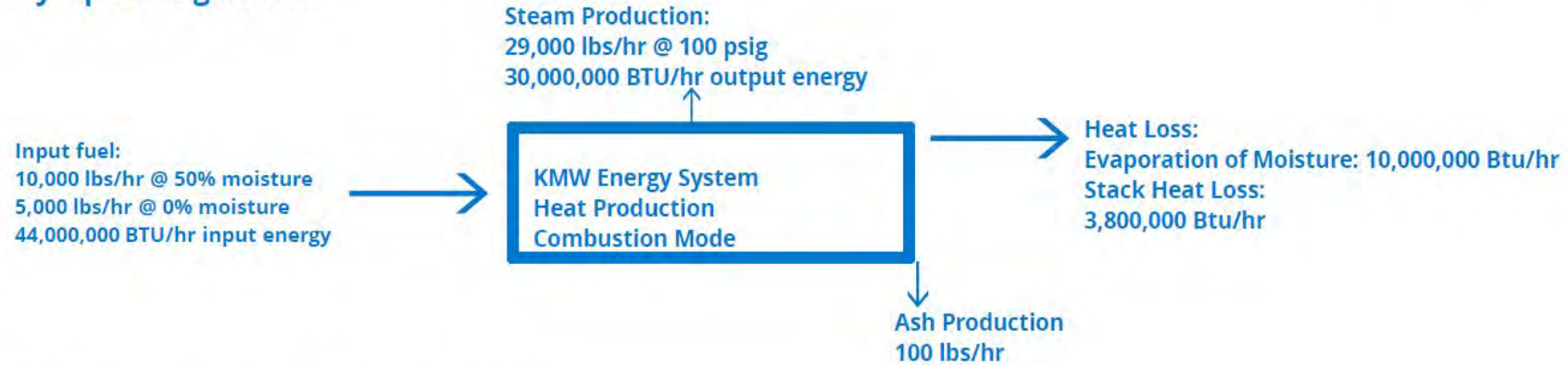

Combined Heat and Biochar Production Mode:

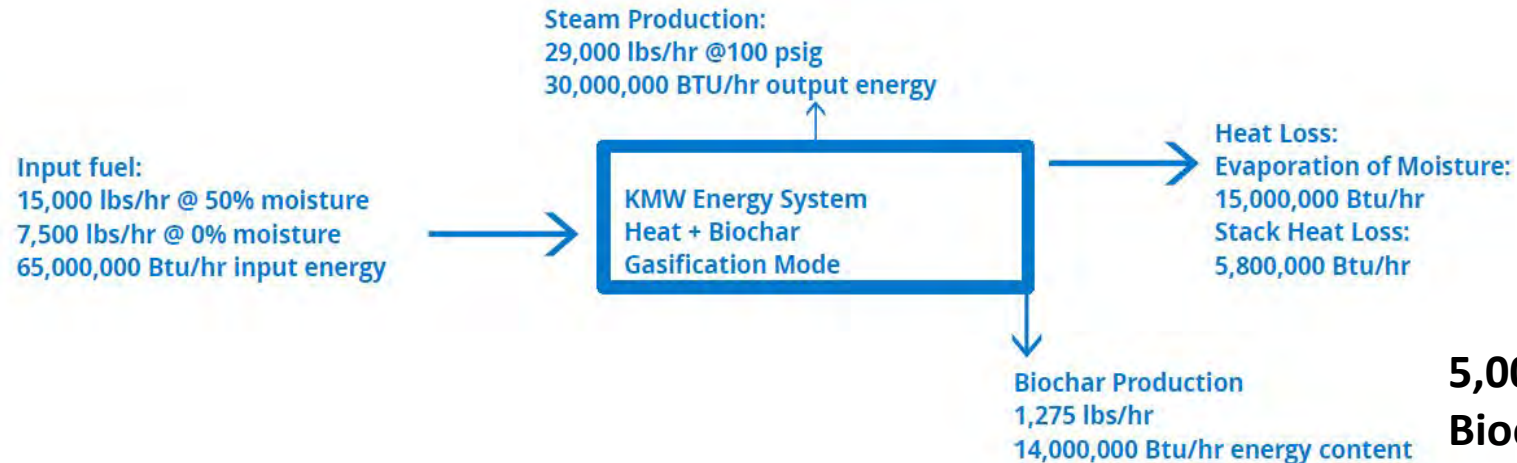

17

**5,000 tph
Biochar**

www.kmwenergy.com

Biomass Boilers Carry Biochars in Exhaust



Photo: Capital Press
Freres Lumber

Source: Wellons, Inc.
www.wellonsusa.com

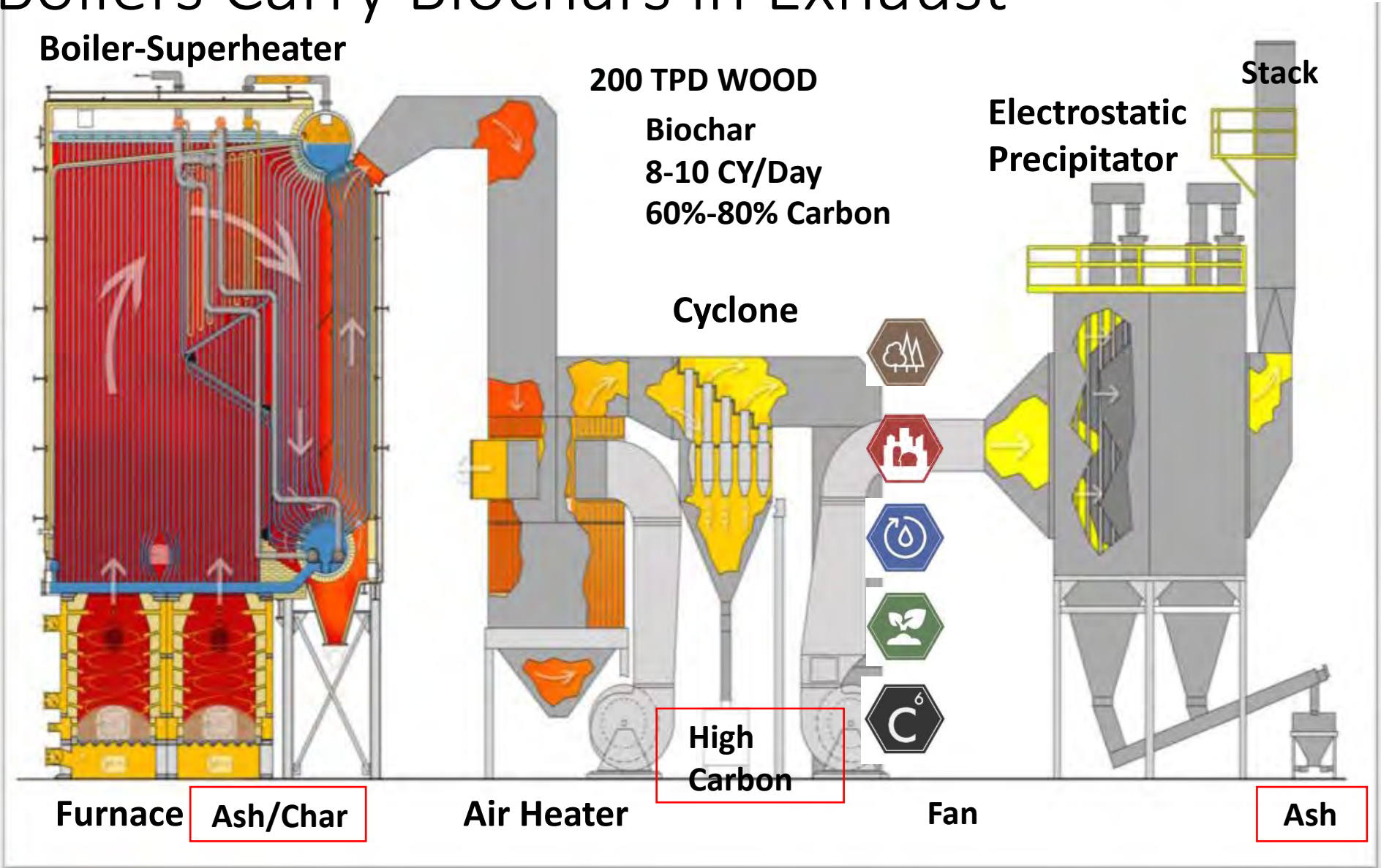

96 Ag and Wood Biomass Plants Could Recover Biochar 27 Million Tons per year -> 3,200 MW

Type	No.	MWe	MMTPY dry
Biomass Plants	159	5,583	45
Ag Waste	6	203	2
Wood	90	3,036	24
MSW	66	2,346	19
Industry			70

[U.S. Biomass Power Plants biomassmagazine.com](http://biomassmagazine.com), EIA

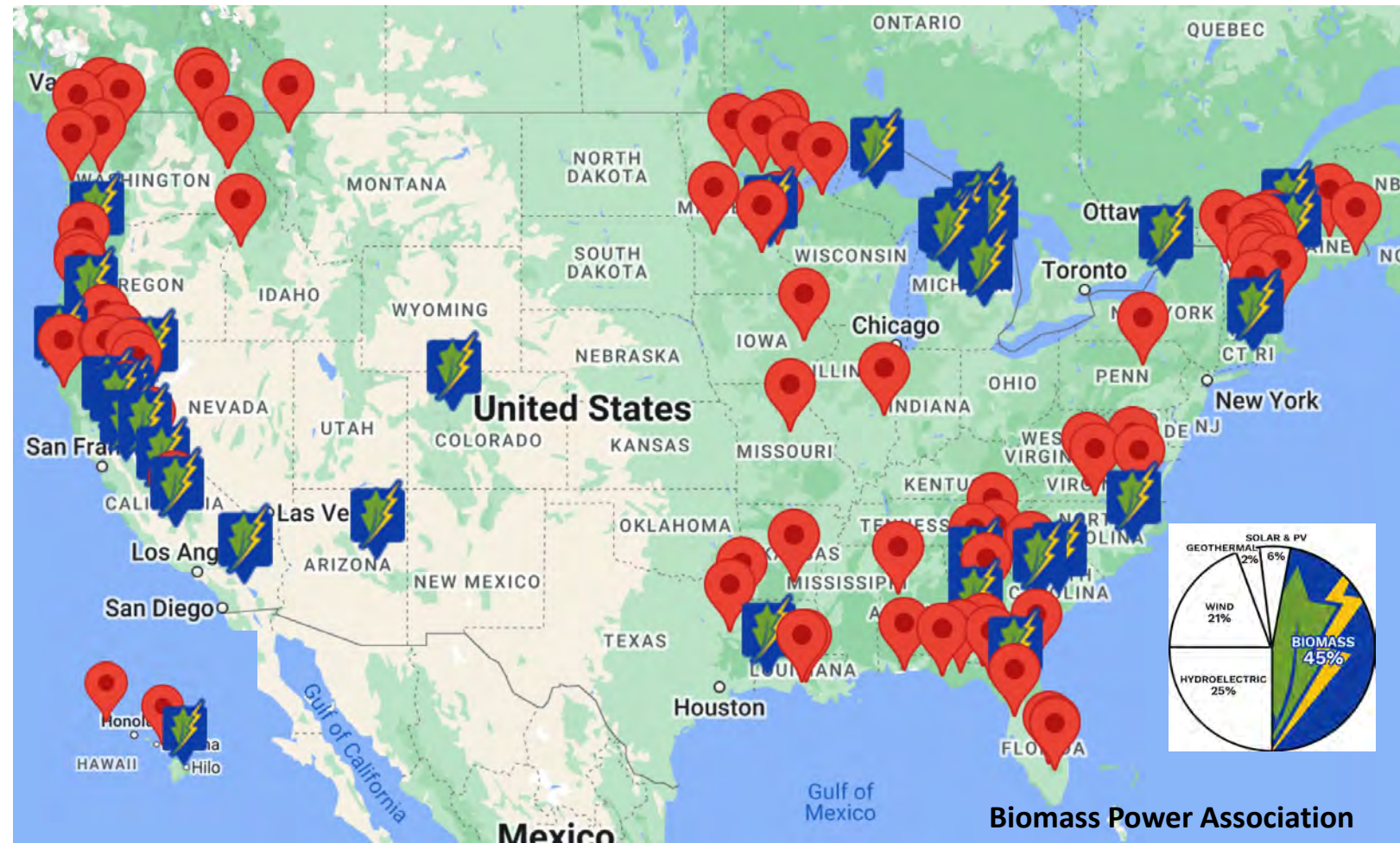

Biomass Power Association
usabiomass.org

US Biochar Production is Growing

135 producer/55 tech suppliers

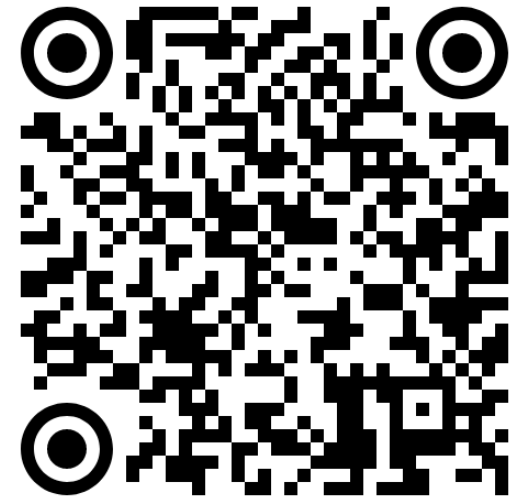
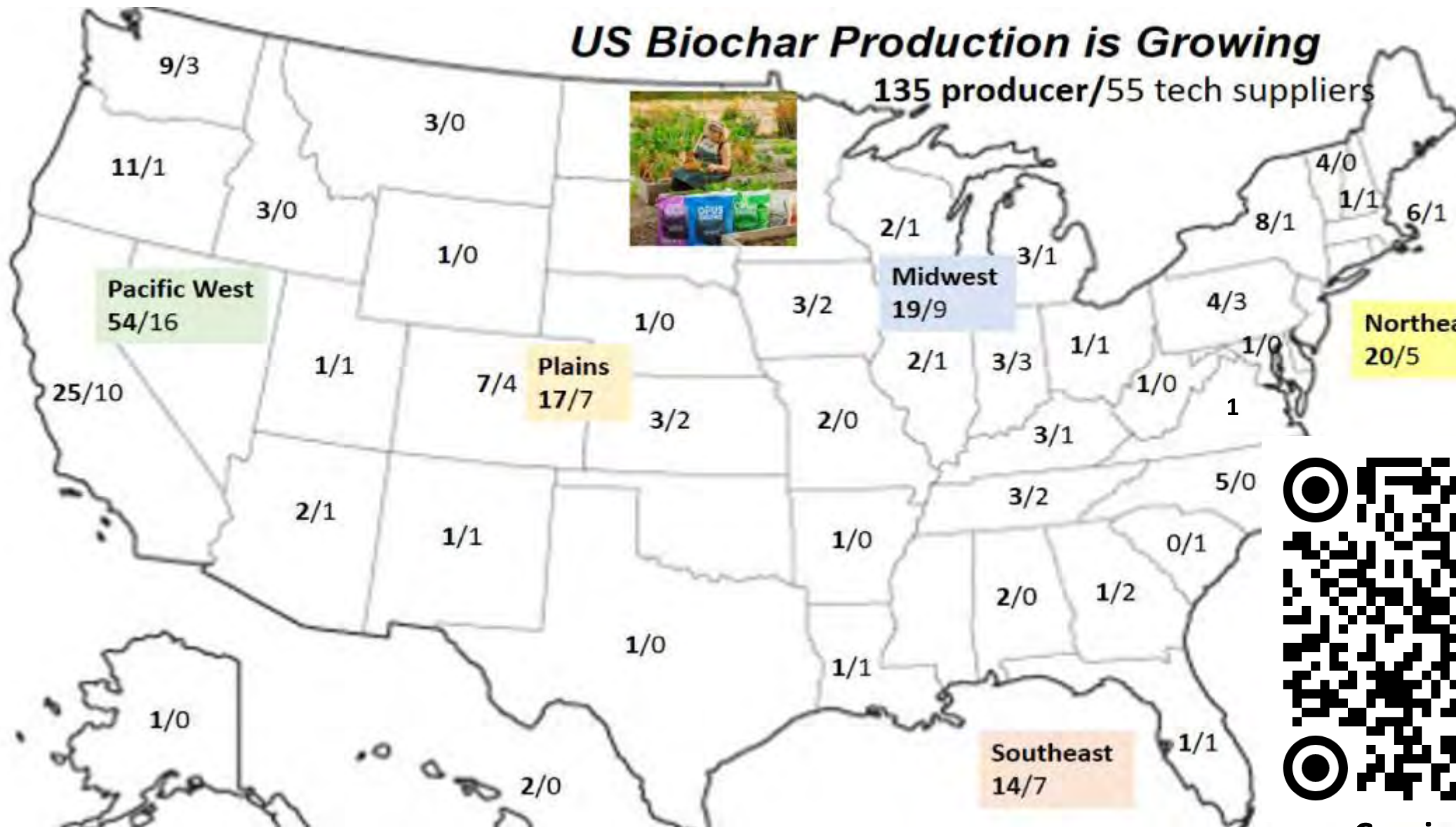

Coming Soon:
USBI – IBI Survey
2023-2024

Using Biochar: Biochars are Delivered in Bulk



2 CY 400 lb dry

- High carbon
- Low Volatiles
- Low Ash
- Low Fines
- Good Flowability

Oregon Biochar Solutions
www.chardirect.com

80 CY 8-10 t



From Factory to Use



 **PACIFIC
BIOCHAR**
Pacificbiochar.com

Biochars are Delivered in Bulk Bags



Bulk bag - spout top and bottom



A step deck flatbed truck loaded with 19 pallets of 4 yards – 76 cubic yards of biochar on board. *Biochar Solutions LTD.*



Bags at Distributor
2 pallets/ton

Technologies for Climate Resilience: Renewable Energy, Increase Soil Carbon, Remove CO₂e

Sustainable Biomass 1 Billion tons 500 Million tons C

GREEN CARBON MARKETS
250 Million tons C

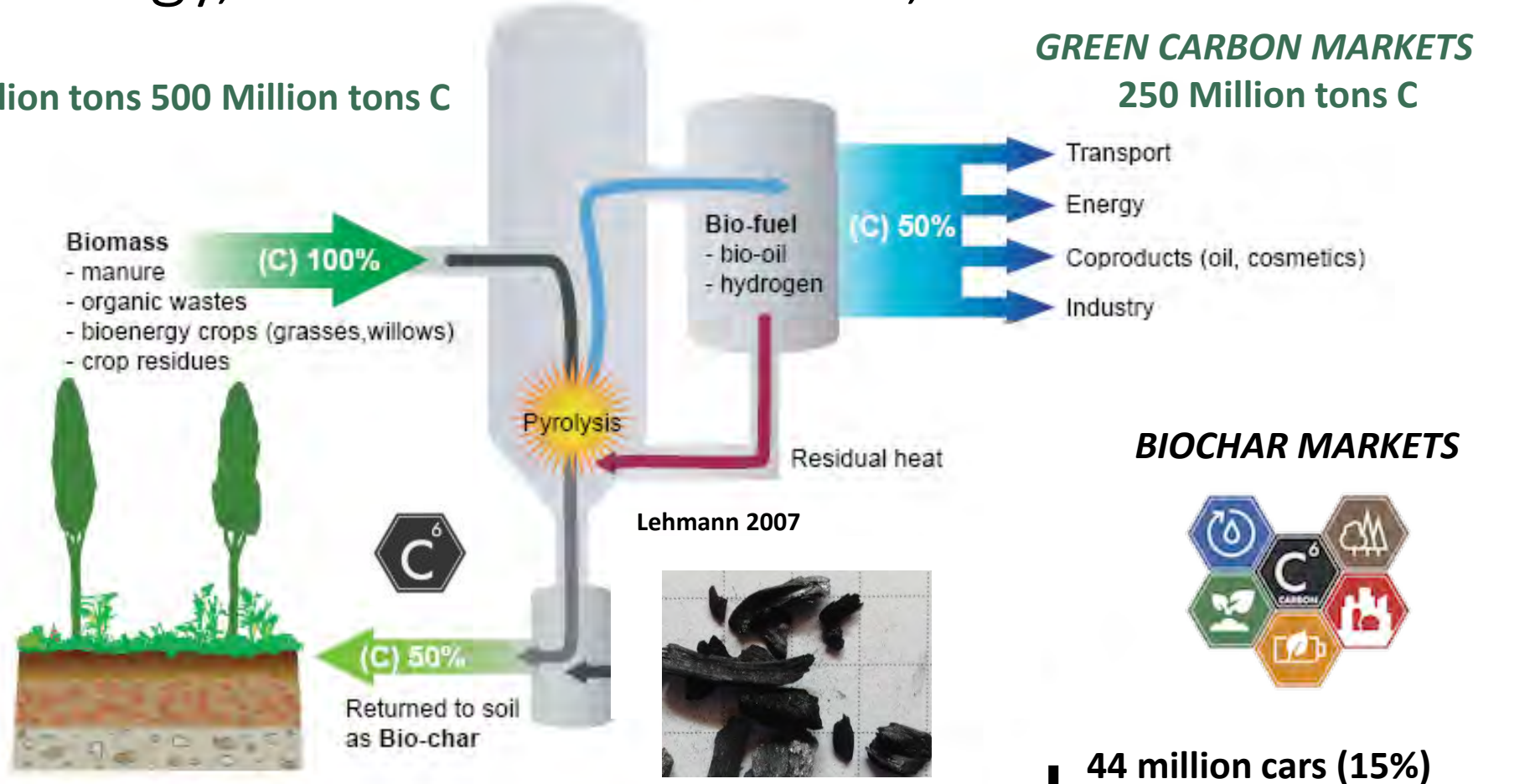
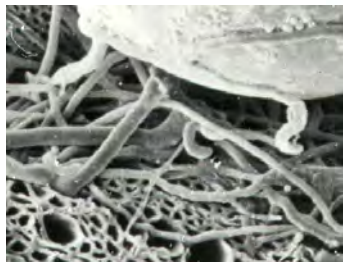
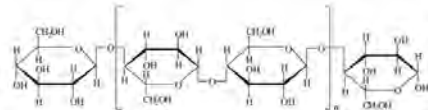

250 million tons C 625 Million tons CO₂e

1 mt CO₂e = 1 Carbon Dioxide Removal Certificate (CDR or CORC™) 2.0-3.2 mtCO₂e/mt

Biochar

Practical Implementation: Biochar Production Technologies

44 million cars (15%)
247 million acres of forest

New climate friendly technologies

convert low-value wood waste to biochar
reduce urban waste, wildfire risk and
facilitate biochar applications.



Carbon Markets fund increased biochar production
reduce costs



USDA and States create tools and opportunities to
increase Soil Carbon and
improve Water Quality and Soil Health



Biochars and biochar amended products from wood residues
help improve food and fiber production and climate resilience.



Just Add Biochar!



Photo: Pacific Biochar

Thank you!

Tom Miles
Executive Director
US Biochar Initiative
tom@biochar-us.org
www.biochar-us.org



Connect

info@biochar-us.org

<https://biochar-us.org> [instagram.com/usbiochar](https://www.instagram.com/usbiochar)

[youtube.com/@USBiocharInitiative](https://www.youtube.com/@USBiocharInitiative)

[linkedin.com/company/us-biochar-initiative](https://www.linkedin.com/company/us-biochar-initiative)

twitter.com/usbiochar

[facebook.com/USbiochar](https://www.facebook.com/USbiochar)

biochar.groups.io



Learning Center
& Fact Sheets