

Dow Performance Silicones

Jet Fuel Resistance Testing

Airfield Applications



As stated in FAA Engineering Brief No. 36 (dated 5/86), “The function of a sealant is to seal the joint between two concrete surfaces. Therefore, the sealant’s strength characteristics are less important than its ability to withstand joint movement and maintain adhesion.” This document goes on further to state that “Silicone sealant is not degraded by contact with jet fuel. Some swelling of the material will normally occur, but it will return to its original shape upon evaporation of the fuel, without loss of bond.”

Generally, for a sealant to be successful in an airfield application, it must meet the following requirements:

- Resistance to ultraviolet light
- Wide temperature flexibility
- Cyclic movement capability (both extension and compression)
- Fuel/oil resistance
- Jet blast resistance

Federal Specifications SS-S-200E, SSS-S-1614A and ASTM Specification D 3569 attempt to test for the above performance requirements. However, when it comes to cyclic movement capability, they all fall short. The best cyclic movement test that closely relates to actual field conditions is ASTM C 719. See Table I for a brief comparison of these specifications.

Since there are few federal or ASTM specifications presently written for silicones, Dow developed a test method to verify that silicone sealants can meet the requirements for airfield applications mentioned above.

A simulated fuel spill test joint (see Figure 1) was chosen along with ASTM C 719 cyclic testing. This test joint in combination with C 719 appeared to be a more accurate depiction of actual field conditions.

The test consists of forming several sealant test joints between two concrete blocks with a dam on top of each block (see Figure 1). The sealant is allowed to cure. The dam is filled with the test

fluid (i.e., jet fuel). The fluid is then allowed to dissipate, as it would in the field. If more than one fluid is to be tested on the same joint, then approximately one week separates each fluid application. At the end of the fluid exposure, these same test joints are then subjected to cyclic testing per the ASTM C 719 specification.

Table I. Specification Comparison

Specification	Sealant Type	Cyclic Movement Capability	
		Extension	Compression
SS-S-200E	Cold Applied	3 cycles @ 0°F (-17°C)	None
SS-S-1614A	Hot Applied	3 cycles @ 0°F (-17°C)	None
ASTM D 3569	Hot Applied	3 cycles @ 0°F (-17°C)	None
ASTM C 719	Cold Applied	10 cycles @ -15°F (-26°C)	10 cycles @ 158°F (70°C)

Figure 1. Simulated Fuel Spill Test Joint

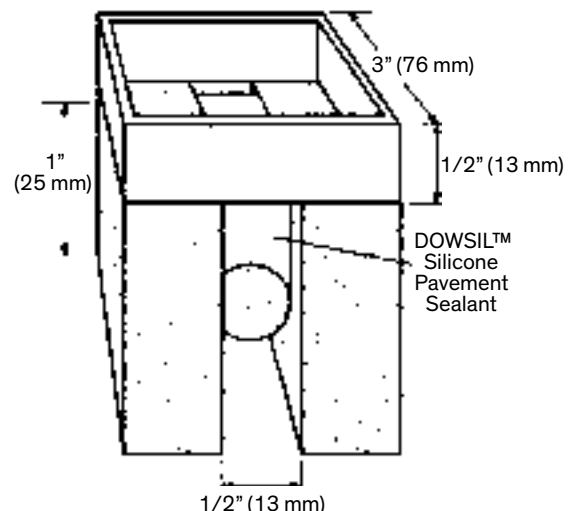

During the initial contact with some fluids, the test joints showed some visual volume increase. However, after dissipation of the fluids, these same test joints did return to their original shape (see Figure 2 and Table II). More importantly, after further subjecting the same test joints to cyclic testing (after fluid dissipation), they showed no signs of bond loss.

The airfield application test method from Dow is a good indication that DOWSIL™ silicone pavement products can provide the necessary airfield performance requirements. But the best indication is Dow's actual field track record, with applications dating back to 1980.

Figure 2. Effect of Fuel Spill on DOWSIL™ Silicone Joint Sealant

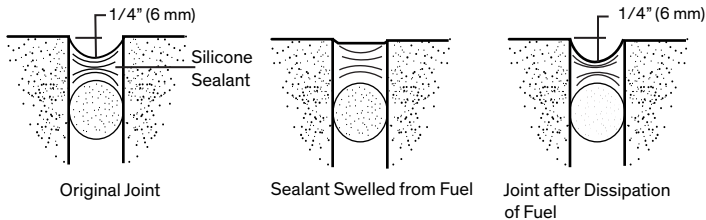

Table II. Approximate Volume Change after Exposure to Fluids

Fluid	Percent Volume Swell – Visual	
	DOWSIL™ 888 Silicone Joint Sealant	DOWSIL™ 890-SL Silicone Joint Sealant
JP-4	5 percent	15-20 percent
Skydrol B	None	None
50/50 Glycol/H2O	None	None
Hydraulic Fluid	None	None

¹After drying, all samples passed +100/-50 percent movement testing.

LIMITED WARRANTY INFORMATION – PLEASE READ CAREFULLY

The information contained herein is offered in good faith and is believed to be accurate. However, because conditions and methods of use of our products are beyond our control, this information should not be used in substitution for customer's tests to ensure that our products are safe, effective and fully satisfactory for the intended end use. Suggestions of use shall not be taken as inducements to infringe any patent.

Dow's sole warranty is that our products will meet the sales specifications in effect at the time of shipment.

Your exclusive remedy for breach of such warranty is limited to refund of purchase price or replacement of any product shown to be other than as warranted.

TO THE FULLEST EXTENT PERMITTED BY APPLICABLE LAW, DOW SPECIFICALLY DISCLAIMS ANY OTHER EXPRESS OR IMPLIED WARRANTY OF FITNESS FOR A PARTICULAR PURPOSE OR MERCHANTABILITY.

DOW DISCLAIMS LIABILITY FOR ANY INCIDENTAL OR CONSEQUENTIAL DAMAGES.

[®]™ Trademark of The Dow Chemical Company ("Dow") or an affiliated company of Dow

© 2018 The Dow Chemical Company. All rights reserved.

30023848

Form No. 62-207-01 D