

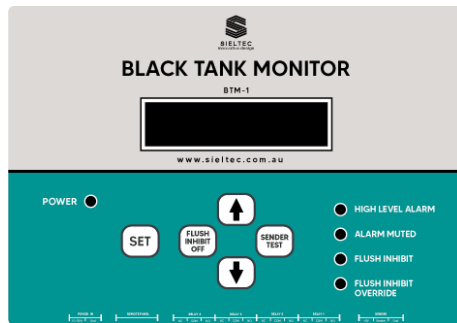

**SIELTEC**  
innovative design



# BTM-1 Black Tank Monitor

## User Manual

Issue 1.0

**Disclaimer of Liability**

Please note that since the installation, operation and maintenance of the Silettec BTM-1 is beyond the control of Sieltec, Sieltec does not responsibility and expressly disclaims liability for damage, loss or expense whether direct or indirect, consequential or incidental arising out of or anyway connected with the installation, operation use or maintenance.

Please also note that while every precaution and effort has been expended to ensure accuracy of this manual, the functionality and specifications may change without notice.

**Copyright Notice Copyright © 2022 by Sieltec Innovative Design.** All rights reserved. Permission to copy, distribute, and/or modify this document is prohibited without express written permission by Sieltec.

**Document Description – BTM-1 Users Manual Rev 1.0**

Date Published – January 2023

This manual is not printed with product distribution for environmental and cost reasons.

Document is available with QR scan of QR code on box or product ensuring latest version of manual is provided. By using this

**Statement of Appreciation**

Thank you for purchasing this BTM-1 from Sieltec. We understand that with this purchase comes a responsibility for Sieltec to ensure the product is fit for purpose and provides many years of trouble free service. If you are not satisfied with this product please contact Sieltec support and we will do all we can to rectify any problem relating to this product.

Hi b be

# BTM-1 Black Tank Monitor

<b>Introduction</b>	<b>5</b>
Typical application	5
Figure 1 BTM-1 Basic Configuration	5
Solution	6
<b>Installation</b>	<b>7</b>
Selecting location	7
Connection to Heads	7
Setting Preset Levels.	7
Figure 2 Input range header	8
Various level standards	8
Setting preset levels	8
Euro or American Standard	9
Muting from Main Unit	9
Connector Configuration	10
Connection to Helm Panel	10
Figure 3 BTM-1 Helm Unit	10
Connection to Heads	10
Connection to Power	10
Table 1 - 2 Pin Wiring Connector (CN1) Power In	11
Connection to Tank Sender	11
Table 2 - 3 Pin Wiring Connector (CN2) Sender In	11
Connection to external devices	12
Table 3 - 12 Pin Wiring Connector (CN3) External connections	12
Table 4 - RJ45 Wiring Connector (RJ1) Remote Panel	13
Typical Remote Solution	13
Technical Specifications	14

# Introduction

## Typical application

Black tanks on large vessels need to be emptied periodically and if that function is not performed expensive repairs can be needed. If an overflow happens on a black tank, the overflow may potentially ruin a filter usually located in the breather system. The filter is designed to allow the black tank to vent to the atmosphere but reduce odour from the tank.

The applications for the Sieltec BTM-1 helps boat owners or skippers know when the black tank needs to be emptied to avoid the overflow problem.

An audio alarm will alert when the black tank reaches a preset level. This audio alert is accompanied by a flashing light on the remote panel indicating attention is required. If that alert is ignored, at a higher black tank level the flushing function of the heads is inhibited. This flush inhibit function also causes an audio alarm and flashing light at the remote panel. Once again these can be acknowledged to silence the alarm and stop the LED from flashing.

In the event the flush inhibit function needs to be overridden, it can be easily controlled by the main BTM-1 unit.

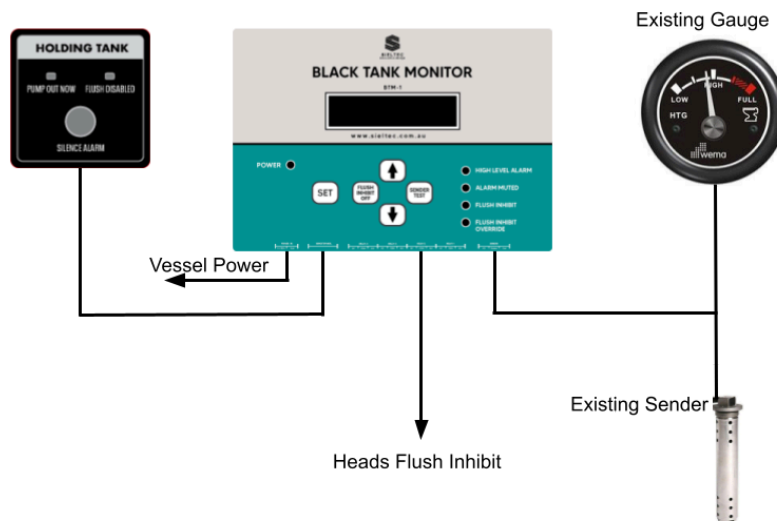

Figure 1 BTM-1 Basic Configuration

## Solution

A main unit is connected to the black tank resistive sensor. When the BTM-1 is installed two levels are set using a simple push button programming method.

Level 1 sets the sender level for the alarm state. When this level is met as the black tank fills, an audio alarm sounds and a small LED flashes at the helm on a 50mm x 50mm remote panel. The alarm can be acknowledged and silenced with a button push at the helm. When the alarm is silenced the light will stop flashing and will simply stay illuminated. The alarm silence will remain latched in a silent state until the level of the black tank reduces below the level set for the alarm activation. When the black tank level reduces below the preset alarm level the alarm silence is disabled and the alarm will work normally next time the Black tank level rises above the alarm level.

Level 2 sets the sensor level where the flush inhibit is enabled. Flush inhibit ensures that the tank cannot overflow and encourages action to empty the tank. When Level 2 is reached, once again the alarm will sound and the corresponding LED at the helm will flash. If the alarm is silenced the alarm will stop and the flashing LED will simply remain illuminated.

In the very rare event that the tank sender unit has failed, it is possible that the gauge may indicate full when the holding tank is in fact empty. In this case, the flush inhibit function will be activated, preventing the heads from being flushed even if the holding tank is empty. In this rare case the Flush inhibit function can be overridden at the main unit by pressing the "Flush Inhibit Off" button. When this button is pressed, the "Flush Inhibit" LED will extinguish and the "Flush Inhibit Override" LED will light. Please be aware that the override function is for a case when some part of the system has failed and a false full signal is preventing the heads from operating. If the holding tank is in fact full and this function is overridden, the holding tank will overflow through the breather system. The flush inhibit override resets to normal operation when the level of the black tank reduces below the flush inhibit (Level 2) level.

The unit can operate on 12 or 24 volt systems, is reverse polarity protected and can be retrofitted to existing installations.

# Installation

## Selecting location

Most boats have the BTM-1 mounted in the engine or equipment room or close to the sender signal. Please select a location that is not subjected to extreme vibration, extreme heat or water ingress. The cable connection is by pluggable phoenix connectors. The cable to the remote readout is a standard Cat 5 cable with no crossover.

## Connection to Heads

The output of the main unit has simple normally open or normally closed contacts. These are dry contacts to ensure galvanic isolation to the vessel electrical system. Breakout to multiple isolated heads may be provided in an external device available from Sieltec if required.

The exact configuration of the flush inhibit will vary for different manufacturers. Assistance will be provided to resolve any interface issues if required. Normally open or normally closed relay contacts are available for this purpose.

## Setting Preset Levels.

The unit has two levels to be set by the installer. Level 1 is the level which causes an audible alarm and a LED to flash at the helm. Level 2 is the level which causes the flush function to be inhibited in the heads. The flush inhibit function is to stop damage being caused by the black tank overflowing. The range of the preset levels available when programming is somewhere between 0 and 1023. Depending upon the range of voltages used on the vessel, typically level 1 may be between 500-700 and level two between 800-1000. These levels are arbitrary and are based on the operational parameters of the vessel. Some skippers may like the alarm to sound early so they have plenty of time prior to the flush inhibit function being set. Others may prefer to have the tank at a higher level before the alarm is triggered. In any case the flush inhibit (level 2) should be set higher than the Alarm level (level 1).

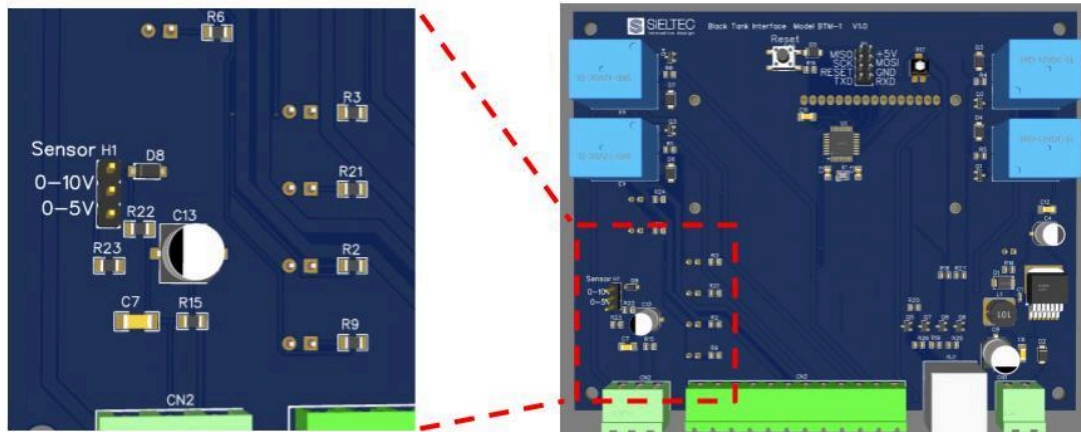

Figure 2 Input range header

### Various level standards

The monitor can handle various standards of sender. Some senders are 0-5 volts and some are 0-10 volts. Either can be accommodated by selecting “Header 1” (H1) on the PC board for the 0-10 volt range.

When in “Sender Test” mode, if “Please Add H1” is shown on the main unit readout when the sender is not at the extreme end of its travel, it means the voltage on the input is too high and H1 should be added. That will increase the voltage range of the unit to handle a 0-10 volt sender. The input to the unit can handle voltages up to 30 volts so the 0-10 volt sender will do no harm even if the Jumper is not in place.

### Setting preset levels

The setting of the preset levels can be achieved with a dummy sender if available. Connect the sender to the main unit, enter programming mode by a long push on the SET button and simply use the push button up and down arrows until the readout shows “Active” or “Inactive”. When the level is “Active” for Level 1 it means the alarm would sound at that level. By varying the preset level the readout will display “Active” and “Inactive” to show what happens when the preset level is varied. Active and Inactive will also show when the sender unit is varied.

The same procedure should be followed for the setting of Level 2, the level that enables “Flush Inhibit”. When the levels are set, simply exit the programming mode (long up arrow push) and the unit is ready for operation.

In the event you want to see the level of the sender unit, simply press and hold the “Sender Test” button and you can see the level of the sender unit. This is also a number between 0 and 1023. This is really a fault finding provision but does allow the installer to know how close to the preset levels the sender unit is. When the number representing the sender is

greater than the number of Level 1 or Level 2 an alarm is enabled or the flush inhibit is enabled.

When you exit programming mode, a small amount of hysteresis is introduced in the system (20%) to stop the alarm or the flush inhibit switching off and on in quick succession. This is so with boat movement, the varying level of the tank will not cause false triggers to occur. This means when the programming mode is exited, if you move the sender level up to where it alarms, it will need to be reduced significantly before the alarm switches off. The same will be seen with the Flush Inhibit function. This hysteresis is removed during Level 1 and Level 2 programming to make setting the level much easier. Also, when in operational mode, the sender output is averaged over 10 samples with 1 second between each sample so that false triggers do not occur as a result of boat movement. Again, this averaging is removed when in level programming or test modes.

## Euro or American Standard

The sender input can handle both Euro style senders or American style senders. The Euro style senders are usually 0-180 ohms and have low resistance for empty and high resistance for full. That means low sender voltage for empty and high sender voltage for full.

The American style senders are the opposite with high voltage for empty and low voltage for full. As the main unit senses the voltage on the sender, the difference in sender response needs to be accounted for.

The main unit is set for Euro style senders as default. If the settings are the reverse of what is expected simply do the following.

1. Remove power
2. Press any button on the main unit and hold the button on.
3. Reapply power to the main unit.
4. Remove button press.

The main unit is now set to the opposite style to before this operation. If it were set to Euro it is now set to American. If it were set to American it is now set to Euro.

This will only ever need to be set once.

## Muting from Main Unit

If an external audio alarm is fitted to the 12 pin Phoenix connector on the main unit and the helm panel has been disconnected, the alarm mute button is disconnected. If an alarm sounds and the helm unit is disconnected, the alarm can be muted by pressing the "down Arrow" button on the main unit. This is a secondary mute function that will rarely be used but is available if required.

## Connector Configuration

The connectors on the main unit interface to vessel power, black tank level sender and the remote panel. The remote panel has a Level 1 indicator light, an audio alarm, a Level 2 indicator light and a mute switch.

A 12 pin connector also provides access to relay contacts for the following,

1. Audio Alarm switch in case another audio alarm is required.
2. Level 1 indicator in case another Level 1 indicator is required.
3. Level 2 switched output to disable the flushing of the heads.
4. Level 2 indicator in case another Level 2 indicator is required.

## Connection to Helm Panel

The connection between the main unit and the helm panel is using a normal Cat5 or Cat6 comms cable with RJ45 connectors. The low voltage (5 Volts) signals in the comms cable are Alert LED, Flush Inhibit LED, voltage for the audio alert and the alarm silence button signal. Please do not use the RJ45 connector for any other purpose than to connect the helm panel. If signals are required for other purposes please use the relay outlets on the 12 pin connector as they have higher current carrying capacity.



Figure 3 BTM-1 Helm Unit

## Connection to Heads

The connection to the heads for flush inhibit is galvanically isolated from the main unit by relays. Connection is on a pluggable screw terminal socket with 5.08mm pitch.

## Connection to Power

The Power is connected through a pluggable screw terminal socket with 5.08mm pitch. The power input is reverse polarity protected and has a range of 10 - 35 Volts. All fusing of circuits should be considered external to the main unit.

Table 1 - 2 Pin Wiring Connector (CN1) Power In

Pin	Identifier	Meaning
1	-ve Ground	Vessel Negative supply
2	+ve DC Power Supply	Vessel Positive Supply 12 or 24 volt

### Connection to Tank Sender

Connection to the black tank sender unit is through a pluggable screw terminal socket with 5.08mm pitch. The sender ground and variable resistor output are required. Power needs to be applied to the original gauge for this to operate. If the unit is to be operated when power to the heads gauge is removed, the Sieltec Analogue Gauge Interface, AGI-1 can be used to allow that function.

Table 2 - 3 Pin Wiring Connector (CN2) Sender In

Pin	Identifier	Meaning
1	-ve Ground	Vessel Negative supply
2	Sender output	Sender output to existing gauge
3	+5 Volt	If required for alternate sender applications

## Connection to external devices

The 12 pin connector provides an interface to external devices in case where other alert systems are required. Each relay has both normally open and normally closed presented at the 12 pin connector. The most commonly used relay output is relay 3 which carries the flush inhibit signal to prevent the heads being flushed when the tank is full.

Table 3 - 12 Pin Wiring Connector (CN3) External connections

<b>Pin</b>	<b>Identifier</b>	<b>Meaning</b>
1	Relay 4 NC contact	Level 2 N/C Flush inhibit indicator
2	Relay 4 Common contact	Level 2 Flush inhibit indicator common
3	Relay 4 NO contact	Level 2 N/O Flush inhibit indicator
4	Relay 3 NC contact	Level 2 N/C Flush inhibit switching contact
5	Relay 3 Common contact	Level 2 Flush inhibit common (to Heads)
6	Relay 3 NO contact	Level 2 N/O Flush inhibit switching contact
7	Relay 2 NC contact	Level 1 N/C switching contact
8	Relay 2 Common contact	Level 1 Alarm common
9	Relay 2 NO contact	Level 1 N/O switching contact
10	Relay 1 NC contact	Audio Alarm N/C switching contact
11	Relay 1 Common contact	Audio Alarm common
12	Relay 1 NO contact	Audio Alarm N/O switching contact

Table 4 - RJ45 Wiring Connector (RJ1) Remote Panel

Pin	Identifier	Meaning
1	-ve Ground	Vessel Negative supply
2	Mute button +ve	Mute button +5v to trigger audio alarm mute
3	Level 2 LED -ve	Switched to ground by main unit to turn on Level 2 LED on remote panel
4	+5 Volt	Supplied by main unit
5	Level 1 LED -ve	Switched to ground by main unit to turn on Level 1 LED on remote panel (flashing)
6	+5 Volt	Supplied by main unit
7	Audio alarm -ve	Switched to ground by the main unit to turn on and off the audio alarm on the remote panel.
8	+5 Volt	Supplied by main unit

## Typical Remote Solution

A typical remote solution used to effectively remotely monitor the boat black tank levels using the Sieltec interface is the Victron CerboGX. This system allows remote monitoring using the Victron Virtual Remote Monitoring (VRM) service. The output from the BTM-1 simply connects to one of the digital inputs on the CerboGX. A Black Tank alarm can be set on the CerboGX so it is obvious what parameter is monitored associated with that digital input. The full setup of the CerboGX can be found on the Victron Website.

## Technical Specifications

Power Supply	
Supply Voltage	9 - 35 Volts DC
Supply Protection	Continuous reverse polarity protection
Supply current	<100mA
Power Supply connector	Phoenix 5.08 Pitch, pluggable screw terminal
Relay connector	Phoenix 5.08 Pitch, pluggable screw terminal 12 pin
Maximum Relay Current	3 Amps, normally open and normally closed contacts
Remote Panel connector	RJ45 Cat 5 Straight through cable
Sensor Connector	Phoenix 5.08 Pitch pluggable screw terminal 3 pin
Mechanical	
Enclosure material	Lid and base high impact flame resistant ABS UL94-V0
Main unit dimensions	L206 x W126 x H45
Enclosure fixing	4 screws on flange base
Protection	IP40
Helm Remote Dimensions	50mm x 50mm