

=====

MARCH MEETING

The March meeting will be held on SATURDAY, MARCH 19, at Daniel Webster College, Nashua Airport Tower Building, at 10:00 AM. At this meeting we will be discussing the 1988 IAC Known Sequences and how they may affect the competitors in various categories and aircraft, contest flying strategies, practice methods, and safety. The emphasis will be on the Basic, Sportsman and Intermediate categories. Details to follow in the February Newsletter.

FINANCIAL NOTES

There are still a few of you out there who have not yet paid your 1988 dues. If the symbol "\$\$\$" appears below and to the left of the mailing label on your copy of this newsletter, you fall into this category. If you have not already done so, please send a check for \$5 to our Treasurer, Ken Voegtlin, at 26 Clark Ave., Walpole, MA 02081

IAC 35 CONTACT LIST

President: Neal Frangesh, 399 North St, Duxbury, MA 02332 617-834-7771
 Vice Pres: Augie Bohn, RFD 1, Box 691, Hancock, NH 03449 603-525-3545
 Treasurer: Ken Voegtlin, 26 Clark Ave, Walpole, MA 02081 617-668-5509

FOR SALE

1979 Pitts S-2A, 750 TTAE, Neal Frangesh, 617-834-7771

CALENDAR OF EVENTS

Feb 13	IAC 35 Annual Banquet, Nashua, NH
Mar 19	IAC 35 March Meeting, Nashua, NH,
May 6-8	IAC 52 Category Contest, Montgomery, NY (TENTATIVE DATE)
May 13-15	IAC 11 Four Category Contest, Warrenton, VA
May/June	IAC 35 Judges School (TO BE SCHEDULED)
Sept 9-11	IAC 35 Three Category Contest, Jaffrey, NH
Oct 7-9	IAC 94 Four Category Contest, Vincentown, NJ

NEW ENGLAND AEROBATIC CLUB
399 NORTH STREET
DUXBURY, MA 02332



MR. VAL BEAUDRAULT
RR 1, BOX 1240
WEARE, NH 03281



NEW ENGLAND AEROBATIC CLUB

INTERNATIONAL AEROBATIC CLUB CHAPTER 35

FEBRUARY 1988 NEWSLETTER

MARCH MEETING -----

The March meeting will be held on SATURDAY, MARCH 19, at Daniel Webster College, Nashua Airport Tower Building, at 10:00 AM. At this meeting we will be discussing the 1988 IAC Known Sequences and how they may affect the competitors in various categories and aircraft, contest flying strategies, practice methods, and safety. Several of our more experienced competition pilots and judges will be there to lead the discussion and try to answer your questions. Time permitting, we will also get into the construction of free sequences and/or any other topics of interest.

The 1988 IAC Known Sequences were published in the January issue of "Sport Aerobatics". If your eyes are good enough, please take a few minutes to look them over before the meeting. If the sequence drawings are too small for you to read, don't worry. Headquarters was kind enough to send a set of large and very legible sequence drawings to all chapter presidents. Copies will be available at the meeting. If you can't make the meeting but would like to have copies mailed to you, please give me a call at 617-834-7771.

1988 ANNUAL AWARDS BANQUET -----

Sixty-seven members and guests attended the 1988 ANNUAL AWARDS BANQUET at the NINETY NINE RESTAURANT in Nashua, NH on Saturday, Feb 13. We are pleased to report that there were no arrests and no fires following this year's banquet.

Following the dinner, our guest speaker, Mr. Chip Collins, former Senior Engineering Test Pilot for MIT and Draper Laboratories, who told us about the highlights of his 54 career in aviation which included combat flying during WWII and experience as a test pilot.

Following Chip's talk, Ward Bryant stepped up to present WARD'S AWARDS for 1987. During this infamous ceremony, Captain Bryant officially recognized those among us whose aeronautical or terrestrial deeds deserved special recognition.

Special thanks are due Joe Benkert, owner of the "Pilot Shop" at Norwood Airport for providing many of the raffle prizes to the chapter at a substantial discount.

1988 CONTEST -----

Chapter 35 will hold a three category contest at Silver Ranch Airpark in JAFFREY, NH on September 9-11. Augie Bohn will be the Contest

NEW ENGLAND AEROBATIC CLUB

INTERNATIONAL AEROBATIC CLUB CHAPTER 35

MARCH 1988 NEWSLETTER

APRIL MEETING

The April meeting will be held on SATURDAY, APRIL 16, at Silver Ranch Airpark (Jaffrey Airport) in Jaffrey, NH at 10:00 AM, rain or shine. If you are planning to fly to the meeting, please taxi down the hill and park your aircraft in the lower parking area. Please do not park around the gas pumps or in front of the hanger at the top of the hill.

Weather permitting, we will have a practice flying and judging session immediately following the business meeting. If you have been waiting to try the 1988 Known Sequences or your new free sequence, this is your chance. We will have several of our chapter's judges there to critique your efforts and answer your questions. Score sheets for the 1988 Known Sequences will be available at the meeting. If you want to have your free sequence judged and critiqued, remember to bring at least 5 copies of the score sheets and filmsies.

IF YOU ARE PLANNING TO FLY IN THE PRACTICE SESSION: (1) you must be a current member of IAC and EAA, (2) you must have a valid pilots licence and a current medical, (3) your aircraft must be properly licensed and insured, and (4) you must have a currently packed parachute. These requirements will remain in effect for the duration of 1988. If you have any questions on these requirements, please give me a call at 617-834-7771.

NOTES ON THE LAST MEETING

The March meeting was held on Saturday, March 19, at Daniel Webster College, Nashua Airport Tower Building. Thirty-three members and guests were in attendance. During the business meeting, there was considerable debate on three items.

First, there was the proposed amendments to the IAC bylaws that would have the officers of IAC elected by the Board of Directors rather than elected by the membership. Several members have already written carefully composed letters to headquarters on this issue. After considerable discussion, a vote was taken. The members of Chapter 35 were overwhelmingly against the proposed change.

Second, there was the issue of IAC's relationship with EAA. EAA seems to feel that IAC is placing too much emphasis on competition and not doing enough to support the parent organization. On the other hand IAC seems to feel that EAA wants too much control over IAC. The positions of both organizations seem a bit fuzzy. The general consensus seemed to be that being part of EAA has a lot of advantages and that we should try to work out our problems with EAA. A vote was

=====

taken. The members of Chapter 35 were overwhelmingly against severing IAC's relationship with EAA.

Finally, there was the question of Chapter 35's support of the U.S. Aerobatic Team. On the table for consideration was a letter from the U.S. Aerobatic Foundation requesting the each IAC chapter donate \$500 to the team. The ensuing debate centered around how much we should donate and whether our donation should come out of the treasury or from special contributions from individual members. Several members spoke persuasively in favor of both methods. A vote was taken. It was decided that special contributions would be solicited from the membership and combined with a modest contribution from the treasury and forwarded to the U.S. Aerobatic Foundation in the name of Chapter 35. Approximately \$100 was collected at the meeting. Additional contributions will be solicited through the newsletter. See the next newsletter item.

Following the business meeting, IAC 35 pilots Mike Goullan, Erik Fleming, Paul Voegtlin and Rick Runnels gave us their views on the 1988 IAC Known Sequences. Their presentations were excellent and there were many questions from the floor on how certain maneuvers should be flown. We will probably have similar "hangar flying" sessions in the future.

SUPPORT FOR THE U.S. AEROBATIC TEAM

The World Aerobatic Championships will be held this late this summer in Red Deer, Alberta in Canada from July 31 through August 12. The United States will be sending both men's and a women's teams to the event. The team has asked for and deserves our support. Please send your contribution to our treasurer, Ken Voegtlin, at 26 Clark Ave, Walpole, MA 02081. Your contribution will be combined with a contribution from the treasury and forwarded to the U.S. Aerobatic Foundation in the name of Chapter 35. Approximately \$100 was collected at the March meeting. Please mail your contribution to Ken as soon as possible.

IS YOUR PRACTICE AREA STILL LEGAL?

Having problems with 727's flying over or through your favorite practice area? Well in case you haven't noticed, the FAA recently implemented their new East Coast Plan which relocated many airways and intersections. THESE CHANGES ARE NOT SHOWN ON THE CURRENT NEW YORK SECTIONAL. The easiest way to see if your practice area is still legal is to check the current Jeppesen Low Altitude Enroute Charts. Remember, airways are 8 nautical miles wide, 4 miles on each side of the centerline. RECHECK YOUR PRACTICE AREA and make sure it's still legal!

=====

ONE LAST TIME.....

If the symbol "\$\$\$" appears below and to the left of the mailing label on your copy of this newsletter, our records show that we have not received your 1988 dues. If you are a potential new member, we will keep you on the mailing list for three months while waiting for your check. If are already a member and have not yet paid your dues, give us a break and pay up before we have to turn the matter over to a collection agency and do further damage to your already questionable credit rating. Please send your check for \$5 to our Treasurer, Ken Voegtlin, at 26 Clark Ave., Walpole, MA 02081.

IAC 35 CONTACT LIST

If you have any questions, suggestions, items for the "FOR SALE" or "CALENDAR OF EVENTS" columns, etc., please feel free to contact any of the chapter officers whose names, addresses and phone numbers are listed below:

President: Neal Frangesh, 399 North St, Duxbury, MA 02332 617-834-7771
 Vice Pres: Augle Bohn, RFD 1, Box 691, Hancock, NH 03449 603-525-3545
 Treasurer: Ken Voegtlin, 26 Clark Ave, Walpole, MA 02081 617-668-5509

FOR SALE

1976 Decathalon, 180 HP, heavy crank, Ken Grant, 603-362-4848

CALENDAR OF EVENTS

Apr 16 IAC 35 April Meeting, Jaffery, NH,
 Apr 29-1 IAC 52 Contest, Montgomery, NY
 May 13-15 IAC 11 Four Category Contest, Warrenton, VA
 Jun 3-5 IAC 58 Four Category Contest, Maytown, PA
 Jul 31-12 World Aerobatic Championships, Red Deer, Alberta
 Aug 8-12 IAC Championships, Fond du Lac, WI
 Sep 9-11 IAC 35 Three Category Contest, Jaffrey, NH
 Oct 7-9 IAC 94 Four Category Contest, Vincentown, NJ

NEW ENGLAND AEROBATIC CLUB
399 NORTH STREET
DUXBURY, MA 02332



MR. VAL BEAUDRAULT
RR 1, BOX 1240
WEARE, NH 03281



NEW ENGLAND AEROBATIC CLUB

INTERNATIONAL AEROBATIC CLUB CHAPTER 35

MAY 1988 NEWSLETTER

JUNE MEETING -----

The June meeting will be held on SATURDAY, JUNE 18, at Silver Ranch Airpark (Jaffrey Airport) in Jaffrey, NH at 10:00 AM, rain or shine. Weather permitting, we will have a practice flying and judging session immediately following the business meeting.

NOTES ON THE LAST MEETING -----

The May meeting was held on Saturday, May 21, at Silver Ranch Airpark (Jaffrey Airport) in Jaffrey. Eighteen members and guests were present. For the second month in a row the weather was terrible and we were unable to do any practice flying. During the business meeting we decided to hold a special practice session next Saturday, May 28, to give our pilots a chance to practice for Chapter 58's upcoming Four Category Contest in Maytown, PA on June 3-5. See next newsletter item and Calendar of Events.

SPECIAL PRACTICE SESSION TO BE HELD MAY 28 -----

Weather permitting, there will be a special practice session on SATURDAY, MAY 28, at Silver Ranch Airpark (Jaffrey Airport) in Jaffrey, NH at 10:00 AM. Several of Chapter 35's judges will be there to critique your efforts and sharpen your skills. If you are planning to fly in any of this summer's contests, you should take advantage of this opportunity. For more information, call Vice President Augie Bohn at 603-525-3545.

FINAL FLIGHT -----

Tragedy struck when 1988 US Aerobatic Team member Harold Chappell was killed on May 24 while flying his new monoplane at Pontiac, Michigan. The crash was apparently caused by structural failure during a low pass over the runway. No additional details on the accident are available at this time.

Harold was a member of the 1984, 1986 and 1988 US Aerobatic Teams and was a candidate for IAC president in 1987. He was one of the few US Team members to compete in contests here in the northeast. His Four Minute flight in Unlimited at the Red Lion, NJ contest several years ago was truly spectacular. He was a warm friendly person who will be missed by all who had the pleasure of knowing him.

=====

ORANGE COUNTY CONTEST RESULTS

The 1988 northeastern contest season opened on the weekend of April 30 when IAC Chapter 52 held their Four Category Contest at the Orange County Airport in Montgomery, NY. Chapter 35 was well represented in the air and on the judging line. Our pilots brought home three trophies. Jerry Bell won first place in Sportsman. Jim Thompson took fourth place in Sportsman and won the trophy for Best First time Competitor. Mike Goullan won third place in Advanced. Val Beaudrault served as Chief Judge while Ward Bryant and Rocky Ammon served as Judges. The contest results were as follows:

SPORTSMAN	INTERMEDIATE	ADVANCED	UNLIMITED
-----	-----	-----	-----
1. Jerry Bell	1. B. Finnigan	1. C. Chanclu	1. R. Gagne
2. K. Schrodtt	2. A. Cillarolo	2. M. Mallet	2. I. Groom
3. Ed Ruhl	3. Earle Swan	3. Mike Goullan	
4. Jim Thompson	6. Tom Teller		
6. Art Spillos			
12. Charlie Ryan			

DONATIONS TO THE U.S. AEROBATIC TEAM

The U.S. Aerobatic Team needs and deserves our support. Chapter 35's support will consist of special contributions from the members combined with a contribution from the treasury. We have already received a total of \$294 in contributions from the members. We are also soliciting corporate contributions from aviation businesses in New England. If you have not already done so, please mail your contribution to our treasurer, Ken Voegtlin, at 413 Highland Street, E. Bridgewater, MA 02333.

Chapter members Erik Fleming and Melissa Zills have volunteered to set up a stand at the EAA 726 Fly-In at Orange, MA on June 25-26 to solicit contributions for the team and sign up new members for Chapter 35. They too will need your support. They need some aerobatic airplanes to put on display and some people to help man the stand. If you can help, please call Erik at 617-371-0748 or Melissa at 203-693-4070.

1988 DUES

If the symbol "\$\$\$" appears below and to the left of the mailing label on your copy of this newsletter, our records show that we have not yet received your 1988 dues. If you are a potential new member, we will keep you on the mailing list for three months while waiting for your check. Please send your check for \$5 to our Treasurer, Ken Voegtlin, at 413 Highland Street, East Bridgewater, MA 02333.

=====
IAC 35 CONTACT LIST

If you have any questions, suggestions, items for the "FOR SALE" or "CALENDAR OF EVENTS" columns, etc., please feel free to contact any of the chapter officers whose names, addresses and phone numbers are listed below:

President: Neal Frangesh, 399 North St, Duxbury, MA 02332 617-834-7771
Vice Pres: Augle Bohn, RFD 1, Box 691, Hancock, NH 03449 603-525-3545
Treasurer: Ken Voegtlin, 413 Highland Street, E. Bridgewater, MA 02333 617-378-3034

FOR SALE

1976 DECATHALON: 180 HP, heavy crank, Ken Grant, 603-362-4848

CALENDAR OF EVENTS

- May 28-29 Blue Angels, Pease AFB, Portsmouth, NH
Jun 3-5 IAC 58 Four Category Contest, Maytown, PA
Jun 4-5 Blue Angels, Westfield, MA
Jun 11-12 Thunderbirds, Warbirds of NE, Hanscom Field, Bedford, MA
Jun 18 IAC 35 June Meeting, Jaffrey, NH
Jun 25-26 EAA 726 Fly-In, Municipal Airport, Orange, MA
Jun 25-26 Concord Airshow, Bob Hoover, Concord, NH
Jul 31-12 World Aerobatic Championships, Red Deer, Alberta
Aug 8-12 IAC Championships, Fond du Lac, WI
Sep 9-11 IAC 35 Three Category Contest, Jaffrey, NH
Oct 7-9 IAC 94 Four Category Contest, Vincentown, NJ

NEW ENGLAND AEROBATIC CLUB
399 NORTH STREET
DUXBURY, MA 02332



MR. VAL BEAUDRAULT
RR 1, BOX 1240
WEARE, NH 03281



=====

CHAPTER 35 DONATES \$600 TO THE U.S. AEROBATIC TEAM

Chapter 35 has donated \$600 to the US Aerobatic team. This donation consisted of approximately \$300 in special contributions from the members, \$200 incorporate contributions from aviation businesses in New England, \$60 in donations collected at the EAA 726 Fly-In at Orange, MA on June 25-26 and a \$40 contribution from the treasury.

Special thanks are due Erik Fleming for his effort in soliciting contributions from aviation businesses. Additional thanks are due Chapter members Erik Fleming, Melissa Zils, Val Beaudraut and Priscilla Beaudraut who volunteered to set up a stand at the Orange Fly-In to solicit contributions for the team.

IAC NATIONAL ELECTIONS

If you are a member of IAC, you recently received your Official Ballot for the 1988 IAC election. Candidates for the offices of President, Vice President, Secretary and Treasurer are running unopposed. However, there are seven candidates for the Board of Directors. You are permitted to vote for no more than three.

One of the candidates for the Board of Directors is Liza Weaver from Chapter 94 in New Jersey. Liza is a Director of Chapter 94, a National Judge and the only candidate from the East Coast. The officers of Chapter 35 have endorsed Liza's candidacy and are soliciting your support on her behalf. We feel that the IAC Chapters on the East Coast need a voice on the board. Your vote for Liza will give us that voice.

MAYTOWN CONTEST RESULTS

On the weekend of June 4-5, IAC Chapter 58 held their Three Category Contest at Donegal Springs Airpark in Maytown, PA. There were a total of 30 competitors including 7 from Chapter 35 (*). The weather was clear and visibility was not a problem. However, on Sunday there was a strong wind down the X-axis that made it very difficult to avoid outs at the downwind end of the box. Jim Thompson took second place in Sportsman. The contest results were as follows:

SPORTSMAN -----	INTERMEDIATE -----	ADVANCED -----
1. Chuck Kuerella	1. Angelo Cillarato	1. Matt Chapman
2. Jim Thompson *	2. Bill Finnigan	2. Chuck Krueger
3. Ron Vecchioni	3. Randy Reinhardt	3. Mike Cutshaw
7. Augle Bohn *	5. John Watkins *	4. Mike Goulian *
10. Ed Morse *	9. Jerry Bell *	
	11. Charlie Ryan *	

NEW ENGLAND AEROBATIC CLUB

INTERNATIONAL AEROBATIC CLUB CHAPTER 35

JUNE/JULY 1988 NEWSLETTER

JULY MEETING -----

The July meeting will be held on SATURDAY, JULY 16, at Silver Ranch Airpark (Jaffrey Airport) in Jaffrey, NH at 10:00 AM, rain or shine. Weather permitting, we will have a practice flying and judging session immediately following the business meeting.

NOTES ON THE LAST MEETING -----

The June meeting was held on Saturday, June 18, at Silver Ranch Airpark (Jaffrey Airport) in Jaffrey. Fourteen members were present. The weather finally cooperated and for the first time this year we were able to do some practice flying following the meeting.

1988 MEMBER SURVEY -----

Enclosed with this newsletter you will find a copy of the 1988 Chapter 35 Member Survey Questionnaire. Please take a few minutes to fill it out and mail it back to us. Unlike FAA exams, there are no trick questions. In accordance with applicable state and federal regulations, we have not asked any questions regarding your age, sex, ethnic background, criminal record, etc.

The first few questions are intended give us the information we need to get in touch with you. Each month, several newsletters are returned because you left town without leaving a forwarding address. The rest of the questions are intended to give us a better idea of your aerobatic experience and how you IAC and Chapter 35 can better serve your interests.

The last question is probably the most important and is the only essay question. Please take a few minutes to give us your comments and suggestions on how we can improve Chapter 35. And yes, we also want to hear your complaints. Please don't interpret the relatively small space as an attempt to limit your creativity or stifle dissent. If you have a lot to say, feel free to write in the margins or enclose a note or a letter. We need your input to serve you better.

1988 CONTEST FLYER -----

Also enclosed with this newsletter is a copy of the flyer for our 1988 Contest. NOTICE TO AIRMEN: MAKE YOUR ROOM RESERVATIONS NOW!

=====

SALEM CONTEST RESULTS

On the weekend of June 11-12, IAC Chapter 61 held their Four Category Contest in Salem, Illinois. Chapter 35 member Erik Fleming was the only competitor from Chapter 35 and took second place in Intermediate.

1988 DUES

If the symbol "\$\$\$" appears below and to the left of the mailing label on your copy of this newsletter, our records show that we have not yet received your 1988 dues. If you are a potential new member, we will keep you on the mailing list for three months while waiting for your check. Please send your check for \$5 to our Treasurer, Ken Voegtlin, at PO Box 479, W. Ossipee, NH 03890.

IAC 35 CONTACT LIST

If you have any questions, suggestions, items for the "FOR SALE" or "CALENDAR OF EVENTS" columns, etc., please feel free to contact any of the chapter officers whose names, addresses and phone numbers are listed below:

President: Neal Frangesh, 399 North St, Duxbury, MA 02332 617-834-7771
 Vice Pres: Augle Bohn, RFD 1, Box 691, Hancock, NH 03449 603-525-3545
 Treasurer: Ken Voegtlin, PO Box 479, W. Ossipee, NH 03890 603-323-7833

FOR SALE

1976 DECATHALON: 180 HP, heavy crank, Ken Grant, 603-362-4848

CALENDAR OF EVENTS

Jul 16	IAC 35 July Meeting, Jaffrey, NH
Jul 29	EAA Convention, Oshkosh, WI (thru Aug 5)
Jul 31	World Championships, Red Deer, Alberta (thru Aug 12)
Aug 8-12	IAC Championships, Fond du Lac, WI
Sep 9-11	IAC 35 Three Category Contest, Jaffrey, NH
Sep 15-18	Reno Air Races, Reno, NV
Oct 7-9	IAC 94 Four Category Contest, Vincentown, NJ

A5

NEW ENGLAND AEROBATIC CLUB
399 NORTH STREET
DUXBURY, MA 02332



MR. VAL BEAUDRAULT
RR 1, BOX 1240
WEARE, NH 03281

NEW ENGLAND AEROBATIC CLUB

INTERNATIONAL AEROBATIC CLUB CHAPTER 35

1988 MEMBER SURVEY QUESTIONNAIRE

NAME:

ADDRESS:

CITY:

STATE:

ZIP:

HOME PHONE:

WORK PHONE:

1. Are you a member of IAC? (IAC No.) Yes No

2. Are you a member of EAA? (EAA No.) Yes No

3. Do you have a pilots license? Yes No

4. if you have a pilots license, please indicate current rating. Student
 Private
 Comercial
 ATP

5. Do you fly aerobatics? Yes No

6. Do you own an aerobatic airplane? (Type:) Yes No

7. Do you rent an aerobatic airplane? (Type:) Yes No

8. Do you own a non-aerobatic airplane? (Type:) Yes No

9. Have you ever flown in an IAC contest? Yes No

10. If you have flown in an IAC contest, please indicate highest category flown. Basic
 Sportsman
 Intermed
 Advanced
 Unlimited

11. If you have not flown in an IAC contest, do you plan to do so in the future? Yes No

12. Do you think IAC and/or Chapter 35 place too much emphasis on competition? Yes No

13. Do you think IAC and/or Chapter 35 is too involved with supporting the US Aerobatic Team? Yes No

14. Do you think IAC and/or Chapter 35 needs to have more activities that are not related to competition flying? Yes No

15. Have you ever attended an IAC Judges School? Yes No

16. If Chapter 35 holds a judges school in the first quarter of 1989, are you interested in attending? Yes No

17. Are you an IAC Judge? Yes No

18. If you are an IAC Judge, please indicate rating. Regional
 National

19. Is the mailing address on your newsletter correct? Yes No

20. Comments, sugestions, complaints?

TAPE OR STAPLE HERE

SECOND FOLD HERE

From:

Place
Stamp
Here

IAC CHAPTER 35
399 NORTH STREET
DUXBURY, MA 02332

FIRST FOLD HERE

NEW ENGLAND AEROBATIC CLUB

INTERNATIONAL AEROBATIC CLUB CHAPTER 35

AUGUST 1988 NEWSLETTER

AUGUST MEETING

The August meeting will be held on SATURDAY, AUGUST 20, at Silver Ranch Airpark (Jaffrey Airport) in Jaffrey, NH at 10:00 AM, rain or shine. Weather permitting, we will have a practice flying and judging session immediately following the business meeting.

In order to reduce the delay in getting the practice flying session underway at the August meeting, we will be implementing a new sign up procedure. If you want to fly in the practice session, please sign up as soon as you arrive at the meeting and fill in your name on 5 score sheets for each flight you intend to make.

NOTES ON THE LAST MEETING

The June meeting was held on Saturday, July 16, at Silver Ranch Airpark (Jaffrey Airport) in Jaffrey. Seventeen members were present. For the second month in a row, we had decent weather and we able to do some practice flying following the meeting. Six of our members flew the 1988 Sportsman and/or Intermediate sequences. Member Jean Hardy earned her Basic Smooth Patch. Congratulations Jean!

CONTEST NEWS (AND WE NEED A LITTLE HELP)

Our 1988 contest will held SEPTEMBER 9, 10 & 11 at Silver Ranch Airpark (Jaffrey Airport) in Jaffrey, NH. A copy of the flyer was enclosed with last month's newsletter. Contest Chairman Augie Bohn is expecting a record number of contestants so please make your room reservations now!

We need a little help with the food for the Friday night cookout. The arrangements for food are being handled by our banquet manager, Ruth Bohn, who tells me that we need volunteers to bring the following items: baked goods, casseroles, vegetables, salads, pickles, cheese and crackers, chips and dips and fruit. If you can help us out with any of these items, please give Ruth Bohn a call at 603-525-3545. Don't let your fellow airmen go hungry. Call today!

If you can't cook, lets hope you can fly because the gauntlet has been thrown. In the midst of what surely must have been a long night in the bar at the Red Lion Inn, the pilots of Chapter 94 in New Jersey challenged the pilots of Chapter 35 to a duel. The field of honor will be the box at Jaffrey. The winner will be the chapter whose pilots earn the highest percentage of the total possible score. All

=====

pilots from both chapters entering Sportsman, Intermediate and Advanced will be included. The loser will be entitled to a rematch at Chapter 94's contest at Red Lion in October. Show no mercy! Start practicing!

CHAPTER 35 HISTORY AVAILABLE SOON

"Through the Years with the New England Aerobatic Club", a history of IAC Chapter 35, has just been completed by our chapter historian, Priscilla Beaudrault. This exciting history includes the contest results and activities of the Chapter since it was founded in 1974. Copies will be available at our contest in September and at our monthly meetings for a \$1 donation to help defray costs of having it printed.

1988 MEMBER SURVEY

Enclosed with this newsletter was a copy of the 1988 Chapter 35 Member Survey Questionnaire. As of this date, 30 members have returned their questionnaires. We have received a lot of helpful comments and suggestions. If you haven't already done so, please take a few minutes to fill out and return your questionnaire. We are listening and your ideas will be acted upon.

1988 DUES

If the symbol "\$\$\$" appears below and to the left of the mailing label on your copy of this newsletter, our records show that we have not yet received your 1988 dues. If you are a potential new member, we will keep you on the mailing list for three months while waiting for your check. Please send your check for \$5 to our Treasurer, Ken Voegtlin, at PO Box 479, W. Ossipee, NH 03890.

IAC 35 CONTACT LIST

If you have any questions, suggestions, items for the "FOR SALE" or "CALENDAR OF EVENTS" columns, etc., please feel free to contact any of the chapter officers whose names, addresses and phone numbers are listed below:

President: Neal Frangesh, 399 North St, Duxbury, MA 02332 617-834-7771
 Vice Pres: Augie Bohn, RFD 1, Box 691, Hancock, NH 03449 603-525-3545
 Treasurer: Ken Voegtlin, PO Box 479, W. Ossipee, NH 03890 603-323-7883

=====

FOR SALE

1976 DECATHALON: 180 HP, heavy crank, Ken Grant, 603-362-4848

CALENDAR OF EVENTS

Aug 20 IAC 35 Meeting, Jaffrey, NH

Aug 20-21 Quonset Airshow, Leo, Ray Ban Gold, F-14, F-18

Sep 4 Airshow, Sanford, ME, Russ Gage

Sep 5 Airshow, Plymouth, MA, Jim Parker

Sep 9-11 IAC 35 Three Category Contest, Jaffrey, NH

Sep 24-30 US National Championships, Denison, TX

Oct 7-9 IAC 94 Four Category Contest, Vincentown, NJ

NEW ENGLAND AEROBATIC CLUB
399 NORTH STREET
DUXBURY, MA 02332



MR. VAL BEAUDRAULT
RR 1, BOX 1240
WEARE, NH 03281



NEW ENGLAND AEROBATIC CLUB

INTERNATIONAL AEROBATIC CLUB CHAPTER 35

SEPTEMBER 1988 NEWSLETTER

SEPTEMBER MEETING

The September meeting will be held on SATURDAY, SEPTEMBER 24, at Silver Ranch Airpark (Jaffrey Airport) in Jaffrey, NH at 10:00 AM, rain or shine. Weather permitting, we will have a practice flying and judging session immediately following the business meeting.

In order to reduce the delay in getting the practice flying session underway, we will be using the new sign up procedure. If you want to fly in the practice session, please sign up as soon as you arrive at the meeting and fill in your name on 5 score sheets for each flight you intend to make.

RECORD TURNOUT FOR THE 1988 NEW ENGLAND AEROBATIC CHAMPIONSHIPS

The 1988 New England Aerobatic Championships, held on September 9, 10 & 11 at Silver Ranch Airpark (Jaffrey Airport) in Jaffrey, NH, was a smashing success. As predicted by Contest Director Augie Bohn, we had a record number of contestants. Thirty four pilots from 8 states and 2 Canadian provinces completed a total of 83 flights making this the largest and most successful contest ever held by Chapter 35.

Chapter 35's pilots swept first place in all four categories. Gene Hardy flew her 150 Aerobat to first place in the Basic category followed by Tyson Sawyer in the same airplane. First place in Sportsman went to Canadian member Royden Heays in an 8KCAB Decathlon followed by Roger Marshall in an S-2A and Arthur Spillos in the world's most beautiful Decathlon. Heavy Iron dominated the Intermediate category as Chapter member Erik Fleming took top honors in his S-2B followed by Earl Swan in another S-2B. Our own Gerry Bell was third in his S-1C. Mike Goulian won the Advanced category flying Mike Cutshaw's S-1T. Cutshaw was a very gracious second. Claude Chanclu flew Mudry Aviation's CAP 10B to third. Complete results are attached.

Thanks to the efforts of Banquet Manager Ruth Bohn, we were able to accommodate over 110 people at the Awards Banquet on Saturday night. This is the largest crowd we have ever had at the banquet and the facilities at the Jaffrey Hilton were at their limit. Ward Bryant and the band provided the music and entertainment. Special thanks are due to our friends from Chapter 52 who braved the Jaffrey night to replenish our smoke oil supply during the banquet. Finally, we are sincerely indebted to all of you who helped to make this year's contest a success. The Crew List for the contest is printed on the back of the results. We apologize in advance to those of you whose names we have inadvertently omitted. Thanks again for helping!

=====

NOTES ON THE LAST MEETING

The August meeting was held on Saturday, August 20, at Silver Ranch Airpark (Jaffrey Airport) in Jaffrey. Twenty members were present. For the third month in a row, we had good weather and we able to do some practice flying following the business meeting. Six of our members flew the 1988 Basic, Sportsman or Intermediate sequences.

U.S. TEAMS WIN WORLD CHAMPIONSHIPS

The U.S. Men's and Women's teams won the 1988 World Aerobatic Championships at Red Deer, Alberta. Individually, Henry Haigh of the United States won the Men's Individual Title, Kermit Weeks (US) was second and Yurgis Kairus (USSR) was third. Catherine Maunory of France captured the Women's Individual Trophy followed by Ellen Dean (US) and Elena Kilmovich (USSR). Complete results will be published in SPORT AEROBATICS.

FOND DU LAC RESULTS

At the IAC Championships in Fond du Lac, Wisconsin, Earle Andrews captured the Unlimited Title, Jerry Spear took top honors in the Advanced Category and Glen Fleischer placed first in Intermediate. Results for the Sportsman Category were not available. Complete results will be published in SPORT AEROBATICS.

CHAPTER 35 HISTORY NOW AVAILABLE

"Through the Years with the New England Aerobatic Club", a history of IAC Chapter 35, by our chapter historian, Priscilla Beaudrault, is now available. This exciting history includes the contest results and activities of the Chapter since it was founded in 1974. Copies can be obtained at our monthly meetings. If you want to receive a copy by mail, contact Priscilla (603-529-7929) or any of the chapter officers. To help defray the printing costs, we are asking for a \$1 donation.

1988 MEMBER SURVEY

Enclosed with the June/July newsletter was a copy of the 1988 Chapter 35 Member Survey Questionnaire. As of this date, 39 members have returned their questionnaires. We have received a lot of good comments and suggestions. If you haven't already done so, please take a few minutes to fill out and return your questionnaire. The officers of Chapter 35 are listening. The results of the survey will be published in the October newsletter.

=====

NOMINATIONS FOR 1989 CHAPTER OFFICERS

Now is the time for all patriots and pilots to come to the aid of their Chapter. Nominations are now open for the 1989 Chapter elections. We are looking for a few good men and women to run for the offices of president, vice president, secretary, treasurer, and newsletter editor.

Candidates for office must be members of the Chapter, IAC and EAA. As usual, we have waived the requirements for good moral character. No background checks will be conducted. Candidates should note that the Chapter will be unable to cover any of your campaign expenses and the use of the Chapter Lear Jet for political gain is specifically prohibited.

Nominations may be made in person at the September meeting or by mail using the nomination form at the bottom of this page. Nomination forms should be mailed to our Treasurer, Ken Voegtlin. All persons nominated for office will be contacted to assure that they agree with having their names placed on the ballot. The slate of candidates for 1989 Chapter offices will be announced at the October meeting.

Balloting will be conducted by mail. Ballots will be sent to all current Chapter members with the October newsletter. Ballots will be opened and counted at the at the November meeting. Winners will not be allowed to ask for a recount. The 1989 officers will take office in January 1989.

(CUT ALONG DOTTED LINE)

NEW ENGLAND AEROBATIC CLUB
IAC CHAPTER 35
NOMINATION FORM FOR 1989 CHAPTER ELECTIONS

President: _____

Vice President: _____

Secretary: _____

Treasurer: _____

Newsletter Editor: _____

MAIL TO: Ken Voegtlin
PO Box 479
W. Ossipee, NH 03890

=====

1988 DUES

If the symbol "\$\$\$" appears below and to the left of the mailing label on your copy of this newsletter, our records show that we have not yet received your 1988 dues. Give us a break. Now that Bob Moxter has finally paid his 1988 dues, the rest of you have no excuse.

If you are a potential new member, we will keep you on the mailing list for three months while waiting for your check. Please send your check for \$5 to our Treasurer, Ken Voegtlin, at PO Box 479, W. Ossipee, NH 03890.

IAC 35 CONTACT LIST

If you have any questions, suggestions, items for the "FOR SALE" or "CALENDAR OF EVENTS" columns, etc., please feel free to contact any of the chapter officers whose names, addresses and phone numbers are listed below:

President: Neal Frangesh, 399 North St, Duxbury, MA 02332 617-834-7771
 Vice Pres: Augle Bohn, RFD 1, Box 691, Hancock, NH 03449 603-525-3545
 Treasurer: Ken Voegtlin, PO Box 479, W. Ossipee, NH 03890 603-323-7883

FOR SALE

1976 DECATHALON: 180 HP, heavy crank, Ken Grant, 603-362-4848

1975 CITABRIA 7ECA: 115 HP, 780 TTSN, KX155 Navcom, KT76A Xponder, Hamilton vertical card compass, 5 point harness, auto fuel STC, \$18,000, Bill Kelley, Home: 401-738-5745, Work: 401-331-1771

CALENDAR OF EVENTS

- Sep 24 IAC 35 meeting, Jaffrey, NH
- Sep 24-30 US National Championships, Denison, TX
- Oct 2 EAA 701 Fall Fly-In, Mansfield, MA
- Oct 7-9 IAC 94 Four Category Contest, Vincentown, NJ

NEW ENGLAND AEROBATIC CLUB

INTERNATIONAL AEROBATIC CLUB CHAPTER 35

THE OFFICERS AND MEMBERS OF THE NEW ENGLAND AEROBATIC CLUB,
IAC CHAPTER 35, INVITE YOU TO PARTICIPATE IN THE

1988 NEW ENGLAND AEROBATIC CHAMPIONSHIPS

3+ CATEGORY CONTEST
(SPORTSMAN THRU ADVANCED + BASIC)
SEPTEMBER 9, 10 & 11, 1988

LOCATION: SILVER RANCH AIRPARK
JAFFREY MUNICIPAL AIRPORT, JAFFREY, NH

BY AIR: 15 NM ON THE 022° RADIAL OF THE GARDNER VOR, 110.6 (GDM)
13 NM ON THE 105° RADIAL OF THE KEENE VOR, 109.4 (EEN)

ARRIVAL: RUNWAY: 16-34, 2970' X 50'. UNICOM: 122.8. LH TRAFFIC.
PREVAILING WINDS WNW. RUNWAY 34 (UPHILL) NORMALLY IN USE.
IF RUNWAY 16 (DOWNHILL) IS IN USE, PLEASE USE EXTREME
CAUTION SINCE THE AEROBATIC BOX IS ON THE EAST SIDE OF THE
RUNWAY AND MAY BE ACTIVE.

BY CAR: 5 SM SOUTH OF JAFFREY CENTER ON ROUTE 124

SCHEDULE: FRIDAY, SEPT 9

0900-1900 REGISTRATION AND PRACTICE
1915-1930 CONTEST BRIEFING
1945 COOKOUT

SATURDAY, SEPT 10

0700-0730 PILOT BRIEFING
0800-1900 CONTEST FLYING
2000 AWARDS BANQUET

SUNDAY, SEPT 11

0900-0930 PILOT BRIEFING (IF NECESSARY)
1000-1400 CONTEST FLYING (IF NECESSARY)
1500 AWARDS (IF NECESSARY)

FEES: BASIC: \$30.00
SPORTSMAN: \$35.00
INTERMEDIATE: \$40.00
ADVANCED: \$45.00

HANGARS: AVAILABLE ON A FIRST COME, FIRST SERVED BASIS AT \$8/NIGHT.

(CONTINUED ON REVERSE SIDE)

JUDGES: WE NEED JUDGES, ASSISTANT JUDGES, BOUNDARY JUDGES AND RECORDERS.

CHECKLIST: IAC & EAA MEMBERSHIP CARD
PILOT CERTIFICATE
MEDICAL CERTIFICATE
INSURANCE PAPERS
AIRCRAFT REGISTRATION
AIRFRAME & ENGINE LOGS
OPERATING LIMITATIONS
WEIGHT AND BALANCE DATA
PACKED PARACHUTE (120 DAYS)

PAPERWORK: FLIMSIES (6 LH & 6 RH) AND SCORESHEETS (6) FOR FREESTYLE. BOTH FLIMSIES AND SCORESHEETS MUST BE SIGNED AND DATED BY A CURRENT (1988) IAC JUDGE PRIOR TO THE CONTEST.

HOTELS: WE RECOMMEND THAT YOU MAKE YOUR RESERVATIONS ASAP SINCE SEPTEMBER IS THE "LEAF PEEPER" (TOURIST) SEASON IN NEW HAMPSHIRE. IF YOU NEED ADVICE ON WHERE TO STAY, PLEASE CALL AUGIE BOHN OR NEAL FRANGESH. TRANSPORTATION TO AND FROM MOTELS, ETC. WILL BE PROVIDED. CAMPING IS PERMITTED ON THE AIRPORT.

MOTELS:

SALZBURG INN	PETERBOROUGH, NH	603-924-3808
RAMADA INN	KEENE, NH	603-357-3038
VALLEY GREEN	KEENE, NH	603-352-7350
WINDON	WINCHENDON, MA	617-297-0677

BED & BREAKFAST:

LILAC HILL FARM	JAFFREY, NH	603-532-7278
GALWAY HOUSE	JAFFREY, NH	603-532-8083
JACK SCHWARTZ	JAFFREY, NH	603-532-6240
BENJAMIN PRESCOTT	JAFFREY, NH	603-532-6637
GRASSY POND	JAFFREY, NH	603-532-5166
WESTWINDS	HANCOCK, NH	603-525-6600

INNS:

MONADNOC INN	JAFFREY, NH	603-532-7001
WOODBOUND INN	JAFFREY, NH	603-532-8341
JAFFREY MANOR	JAFFREY, NH	603-532-8069
FITZWILLIAM INN	FITZWILLIAM, NH	603-585-9000

QUESTIONS: AUGIE BOHN, CONTEST DIRECTOR

PROSPECT HILL ROAD	HOME:	603-525-3545
RFD 1, BOX 691	AIRPORT:	603-532-8870
HANCOCK, NH 03449	HANGAR:	603-532-9390

NEAL FRANGESH, CHAPTER PRESIDENT

399 NORTH STREET	HOME:	617-834-7771
DUXBURY, MA 02332	OFFICE:	617-837-6300

JUDGES: WE NEED JUDGES, ASSISTANT JUDGES, BOUNDARY JUDGES AND RECORDERS.

CHECKLIST: IAC & EAA MEMBERSHIP CARD
PILOT CERTIFICATE
MEDICAL CERTIFICATE
INSURANCE PAPERS
AIRCRAFT REGISTRATION
AIRFRAME & ENGINE LOGS
OPERATING LIMITATIONS
WEIGHT AND BALANCE DATA
PACKED PARACHUTE (120 DAYS)

PAPERWORK: FLIMSIES (6 LH & 6 RH) AND SCORESHEETS (6) FOR FREESTYLE. BOTH FLIMSIES AND SCORESHEETS MUST BE SIGNED AND DATED BY A CURRENT (1988) IAC JUDGE PRIOR TO THE CONTEST.

HOTELS: WE RECOMMEND THAT YOU MAKE YOUR RESERVATIONS ASAP SINCE SEPTEMBER IS THE "LEAF PEEPER" (TOURIST) SEASON IN NEW HAMPSHIRE. IF YOU NEED ADVICE ON WHERE TO STAY, PLEASE CALL AUGIE BOHN OR NEAL FRANGESH. TRANSPORTATION TO AND FROM MOTELS, ETC. WILL BE PROVIDED. CAMPING IS PERMITTED ON THE AIRPORT.

MOTELS:

SALZBURG INN	PETERBOROUGH, NH	603-924-3808
RAMADA INN	KEENE, NH	603-357-3038
VALLEY GREEN	KEENE, NH	603-352-7350
WINDON	WINCHENDON, MA	617-297-0677

BED & BREAKFAST:

LILAC HILL FARM	JAFFREY, NH	603-532-7278
GALWAY HOUSE	JAFFREY, NH	603-532-8083
JACK SCHWARTZ	JAFFREY, NH	603-532-6240
BENJAMIN PRESCOTT	JAFFREY, NH	603-532-6637
GRASSY POND	JAFFREY, NH	603-532-5166
WESTWINDS	HANCOCK, NH	603-525-6600

INNS:

MONADNOC INN	JAFFREY, NH	603-532-7001
WOODBOUND INN	JAFFREY, NH	603-532-8341
JAFFREY MANOR	JAFFREY, NH	603-532-8069
FITZWILLIAM INN	FITZWILLIAM, NH	603-585-9000

QUESTIONS: AUGIE BOHN, CONTEST DIRECTOR

PROSPECT HILL ROAD	HOME:	603-525-3545
RFD 1, BOX 691	AIRPORT:	603-532-8870
HANCOCK, NH 03449	HANGAR:	603-532-9390

NEAL FRANGESH, CHAPTER PRESIDENT

399 NORTH STREET	HOME:	617-834-7771
DUXBURY, MA 02332	OFFICE:	617-837-6300

NEW ENGLAND AEROBATIC CLUB

INTERNATIONAL AEROBATIC CLUB CHAPTER 35

THE OFFICERS AND MEMBERS OF THE NEW ENGLAND AEROBATIC CLUB,
IAC CHAPTER 35, INVITE YOU TO PARTICIPATE IN THE

1988 NEW ENGLAND AEROBATIC CHAMPIONSHIPS

3+ CATEGORY CONTEST
(SPORTSMAN THRU ADVANCED + BASIC)
SEPTEMBER 9, 10 & 11, 1988

LOCATION: SILVER RANCH AIRPARK
JAFFREY MUNICIPAL AIRPORT, JAFFREY, NH

BY AIR: 15 NM ON THE 022° RADIAL OF THE GARDNER VOR, 110.6 (GDM)
13 NM ON THE 105° RADIAL OF THE KEENE VOR, 109.4 (EEN)

ARRIVAL: RUNWAY: 16-34, 2970' X 50'. UNICOM: 122.8. LH TRAFFIC.
PREVAILING WINDS WNW. RUNWAY 34 (UPHILL) NORMALLY IN USE.
IF RUNWAY 16 (DOWNHILL) IS IN USE, PLEASE USE EXTREME
CAUTION SINCE THE AEROBATIC BOX IS ON THE EAST SIDE OF THE
RUNWAY AND MAY BE ACTIVE.

BY CAR: 5 SM SOUTH OF JAFFREY CENTER ON ROUTE 124

SCHEDULE: FRIDAY, SEPT 9

0900-1900 REGISTRATION AND PRACTICE
1915-1930 CONTEST BRIEFING
1945 COOKOUT

SATURDAY, SEPT 10

0700-0730 PILOT BRIEFING
0800-1900 CONTEST FLYING
2000 AWARDS BANQUET

SUNDAY, SEPT 11

0900-0930 PILOT BRIEFING (IF NECESSARY)
1000-1400 CONTEST FLYING (IF NECESSARY)
1500 AWARDS (IF NECESSARY)

FEES: BASIC: \$30.00
SPORTSMAN: \$35.00
INTERMEDIATE: \$40.00
ADVANCED: \$45.00

HANGARS: AVAILABLE ON A FIRST COME, FIRST SERVED BASIS AT \$8/NIGHT.

(CONTINUED ON REVERSE SIDE)

Sept. 9-10-11, 1988
New England Aerobic
Championships

Registration

B 3 @ 30.00	90.00
S 17 @ 35.00	595.00
I 10 @ 40.00	400.00
A 5 @ 45.00	225.00
	<hr/>
	\$ 1,310.00

Friday Cookout

72 @ 4.00	288.00
-----------	--------

Saturday Banquet

3 @ 7.50	22.50
92 @ 15.00	1380.00
	<hr/>
	\$ 1,402.50

Rec'd - Mr Goulian	2.00
--------------------	------

Total	<hr/>
	\$ 3,002.50

Sept. 11-10-11-1988

New England Aerobics
Championships

Registration

20.00
225.00
400.00
335.00

B 3 @ 50.00
S 17 @ 35.00
I 10 @ 40.00
A 5 @ 45.00

\$1,310.00

Friday Cookout
958 @ 4.00

388.00

Saturday Banquet

33.20
1,380.00

35 @ 7.20
43 @ 15.00

\$1,408.20

Rec'd - Mr. Conlan

5.00

Total

\$3,008.20

NEW ENGLAND AEROBATIC CHAMPIONSHIPS
 JAFFREY, NH - IAC CHAPTER 35
 SEPTEMBER 9-11, 1988

***** BASIC *****

NO	PILOT	CITY, STATE	CHAPT	AIRCRAFT	N NUMBER	KNOWN	TOTAL	PERCENT
1	JEAN HARDY	ELLIOT, ME	35	150 AEROBAT	N9898J	709.100	709.100	70.2
2	TYSON SAWYER	JAFFREY, NH	35	150 AEROBAT	N9898J	701.100	701.100	69.4

***** SPORTSMAN *****

NO	PILOT	CITY, STATE	CHAPT	AIRCRAFT	N NUMBER	KNOWN	FREE	TOTAL	PERCENT
1	ROYDEN HEAYS	BEACONSFIELD, QUE	35	8KCAB	C-GDLP	1066.738	1120.149	2186.887	85.4
2	ROGER MARSHALL	ANNAPOLIS, MD	11	PITTS S-2A	N60LG	1039.254	1068.688	2107.942	82.3
3	ARTHUR SPILIOS	NASHUA, NH	35	8KCAB	N345AS	1013.491	1065.781	2079.272	81.2
4	PAUL NUSS	PATTON, PA	--	PITTS S-2A	N1974S	949.542	1107.823	2057.365	80.4
5	RON VECCHIONI	MOORESTOWN, NJ	94	SKYBOLT	N100VV	1027.446	990.596	2018.043	78.8
6	LARRY BASHORE	MECHANICSBURG, PA	58	GREAT LAKES	N87G	1006.478	993.264	1999.742	78.1
7	EDWIN RUHL	WASHINGTON DEPOT, CT	--	BABY LAKES	N762	909.625	1070.131	1979.757	77.3
8	BILL MCMAHON	NEW YORK, NY	52	CAP 10B	N10MU	946.984	1030.655	1977.639	77.3
9	ED STOECKLEIN	TARRYTOWN, NY	52	CAP 10B	N10MU	970.754	988.271	1959.025	76.5
10	PAUL GOYETTE	VALLEYFIELD, QUE	35	7ECA	C-FWEQ	946.141	986.681	1932.822	75.5
11	VINCE LAMONIA	BROOKLYN, NY	52	CAP 10B	N10MU	1024.787	865.628	1890.415	73.8
12	JERRY GERDES	NEWBURGH, NY	35	CAP 10B	N10MU	848.929	936.602	1785.531	69.7
13	DICK BOVEY	MANCHESTER, VT	35	STEARMAN	N65649	813.751	902.778	1716.529	67.1
14	ED MORSE	NORWOOD, MA	35	8KCAB	N5041G	974.915	740.024	1714.939	67.0
15	TED BARNARD	LEE-DURHAN, NH	35	PITTS S-1C	N1760	743.532	903.312	1646.844	64.3
16	JARO SVOBODA	MONTREAL, QUE	--	CHIPMUNK	C-FCXT	766.759	800.844	1567.603	61.2
17	MARY MCGRATH	COLCHESTER, VT	35	8KCAB	N5034W	666.576	783.923	1450.499	56.7

***** INTERMEDIATE *****

NO	PILOT	CITY, STATE	CHAPT	AIRCRAFT	N NUMBER	KNOWN	FREE	UNKNOWN	TOTAL	PERCENT
1	ERIK FLEMING	CONCORD, MA	35	PITTS S-2B	N5327C	1837.630	2173.759	1200.696	5212.085	84.1
2	EARLE SWAN	NEW FAIRFIELD, CT	52	PITTS S-2B	N260EF	1746.685	2204.885	1107.766	5059.336	81.6
3	GERRY BELL	HARVARD, MA	45	PITTS S-1C	N4626C	1681.821	2100.793	1075.510	4858.124	78.4
4	PAUL VOEGTLIN	EAST BRIDGEWATER, MA	35	PITTS S-1	N27PB	1544.401	2104.419	1111.312	4760.132	76.8
5	BIFF HAMILTON	CAMBRIDGE, ONT	--	PITTS S-1T	C-GBKF	1620.796	2025.845	1079.870	4726.511	76.2
6	CHARLIE RYAN	CONCORD, MA	35	PITTS S-1C	N4626C	1656.675	1881.677	1135.173	4673.524	75.4
7	GORDON GRAVES	LEBANON, NH	35	PITTS S-1C	N817KC	1640.260	1971.687	1032.613	4644.560	74.9
8	DREW BROWN	DANBURY, CT	52	PITTS S-1	N70W	1698.767	1903.581	1018.200	4620.548	74.5
9	JOHN CORNWELL	HUNTINGTON, NY	52	CAP 10B	N10MU	1489.679	618.466	964.216	3072.360	49.6
10	DONALD MAJERICIK	JERICHO, VT	35	PITTS S-2S	N31485	0.000	1761.930	645.734	2407.664	38.8

***** ADVANCED *****

NO	PILOT	CITY, STATE	CHAPT	AIRCRAFT	N NUMBER	KNOWN	FREE	UNKNOWN	TOTAL	PERCENT
1	MICHAEL GOULIAN	ARLINGTON, MA	35	PITTS S-1T	N210BT	2805.700	3324.800	2084.500	8215.000	79.0
2	MICHAEL CUTSHAW	NEW HARTFORD, NY	35	PITTS S-1T	N210BT	2454.200	3231.600	2039.700	7725.500	74.3
3	CLAUDE CHANCLU	WAPPINGERS FALLS, NY	52	CAP 10B	N10MU	2685.300	3268.700	1770.100	7724.100	74.3
4	ANGELO CILLAROTO	SUSSEX, NJ	94	PITTS S-1S	N66CT	2637.900	3072.200	1929.400	7639.500	73.5
5	CHARLES KALKO	GREENBROOK, NJ	94	EXTRA 230	N230XX	2722.800	3106.400	1695.800	7525.000	72.4

NEW ENGLAND AEROBATIC CHAMPIONSHIPS
 JAFFREY, NH - IAC CHAPTER 35
 SEPTEMBER 9 - 11, 1988

CONTEST DIRECTOR: AUGIE BOHN

CHIEF JUDGE: VAL BEAUDRAULT

JUDGES:	KIETH BIEHL WARD BRYANT ERIK FLEMING	ED MORSE LOIS ROSE RAY ROSE	RALPH SEBEXEN EARLE SWAN LASZLO SZIJJ	FRED WEAVER LIZA WEAVER
---------	--	-----------------------------------	---	----------------------------

ASSISTANT JUDGES:	TED BARNARD LARRY BASHORE JERRY BELL DREW BROWN CLAUDE CHANCLU JOHN CORNWELL	GERRY GERDES PAUL GOYETTE BIFF HAMILTON ROYDEN HEAYS BILL KELLY ROGER MARSHALL	PAUL NUSS LOIS ROSE RAY ROSE ED RUHL RALPH SEBEXEN LASZLO SZIJJ	RON VECCHIONE FRED WEAVER LIZA WEAVER
-------------------	---	---	--	---

VOLUNTEER COORDINATOR: ED MORSE

REGISTRAR: PRISCILLA BEAUDRAULT

TECH INSPECTOR: RUSS GAGE

SAFETY DIRECTOR: PAUL VOEGTLIN

STARTER: BILL STUART

TROPHIES:	ARTHUR SPILIOS	AUGIE BOHN
-----------	----------------	------------

COMMUNICATIONS: BILL SCONCE

BANQUET MANAGER: RUTH BOHN

FOOD COMMITTEE:	ROCKY AMMON PRISCILLA BEAUDRAULT JERRY BELL WARD BRYANT ERIK FLEMING	NORA BRYANT GLORIA GAGE MIKE GOULIAN RITA GOULIAN JEAN HARDY	LIZ LANGEUELL ART MAYNARD MARY MCGRATH GEORGE MEYERS MADELINE MORSE	BILL KELLY LEE SAWYER KEN VOEGTLIN SHIRLEY VOEGTLIN DEBORAH WOLF
-----------------	--	--	---	--

BEVERAGE MANAGER: ROCKY AMMON

ENTERTAINMENT:	WARD BRYANT	ROY CARROLL	DAVE DELROSSI	ELANA DELROSSI
----------------	-------------	-------------	---------------	----------------

BOX MARKING:	ROCKY AMMON AUGIE BOHN	ERIK FLEMING NEAL FRANGESH	MIKE GOULIAN GEORGE MEYERS	ARTHUR SPILIOS
--------------	---------------------------	-------------------------------	-------------------------------	----------------

HOTEL MANAGEMENT: RUTH BOHN

COMPUTER HARDWARE: ERIK FLEMING

SCORE ROOM:	ROCKY AMMON	GINNY TURGEON	KEN VOEGTLIN
-------------	-------------	---------------	--------------

SYSTEMS ANALYST: ROCKY AMMON

CASH MANAGEMENT: KEN VOEGTLIN

AIRPORT MANAGERS:	HARVEY SAWYER	LEE SAWYER
-------------------	---------------	------------



October 7-9, 1988



Flying W
Motel Holly
Concord Motor Inn
Slumberland Motel
Sandman Motor Lodge
Imperial Motel
Red Lion Motel

609-267-6282 6.5 miles, \$42.00
609-859-2229 1.6 miles, \$26.50
609-267-7900 9.2 miles, \$34.00
609-267-5956 6.9 miles, \$26.00
609-298-3700 15.7 miles \$34.93
609-298-3355/298-3950 14.8 miles, \$45.00
609-859-3488 1.4 miles, \$30.00

MOTELS

Sportsman \$35.00
Intermediate \$40.00

ENTRY FEES

\$45.00 Advanced
\$50.00 Unlimited

CONTESTANT CHECKLIST

EAA Membership Card_____
Pilot Certificate_____
Insurance Papers (1 million liability)_____
Airworthiness Certificate_____
Weight & Balance_____
Parachute Packing Slip_____
Flimsies (7L&R) signed and dated 1988_____
Scoresheets (7) signed and dated 1988_____

IAC Membership Card_____
Medical Certificate_____
Aircraft Registration_____
Aircraft Manual_____
Aircraft & Engine Logs_____

TROPHIES

We are proud to announce that the trophies, which will be awarded to the three highest placing competitors in each category and to the best scoring first time competitor, are again being designed and made by artist, Joan Elste. Samples of her work can be seen on the back cover of the July 1987 and April 1988 editions of Sport Aerobatics.

LOCATION: Red Lion Airport, Vincentown, New Jersey

CONTEST DIRECTORS: Liza Weaver: 609-654-7867
Keith Biehl: 201-349-8513

CHIEF JUDGE: Val Beaudrault of IAC Chapter 35

CONTEST SCHEDULE

Friday 10/7: Arrivals, registration, aircraft inspection and practice.
Informal briefing after welcome buffet at airport.

Saturday 10/8: 7.30 a.m. Briefing for all pilots, judges and helpers.
World Famous Filet Mignon and awards Banquet at airport.

Sunday 10/9: 8.30 a.m. Briefing for all pilots, judges and helpers.

NEW ENGLAND AEROBATIC CLUB
399 NORTH STREET
DUXBURY, MA 02332



MR. VAL BEAUDRAULT
RR 1, BOX 1240
WEARE, NH 03281

NEW ENGLAND AEROBATIC CLUB

INTERNATIONAL AEROBATIC CLUB CHAPTER 35

OCTOBER 1988 NEWSLETTER

OCTOBER MEETING

The October meeting will be held on SATURDAY, OCTOBER 22, at Silver Ranch Airpark (Jaffrey Airport) in Jaffrey, NH at 10:00 AM, rain or shine. Weather permitting, we will have a practice flying and judging session immediately following the business meeting.

In order to reduce the delay in getting the practice flying session underway, we will use the new sign up procedure. If you want to fly in the practice session, please sign up as soon as you arrive at the meeting and fill in your name on 5 score sheets for each flight you intend to make.

NOTES ON THE LAST MEETING

The September meeting was held on Saturday, September 24, at Silver Ranch Airpark (Jaffrey Airport) in Jaffrey. Seventeen members were present. Once again, the weather was excellent and we were able to do some practice flying in preparation for the Red Lion contest. Eight of our members flew the 1988 Basic, Sportsman, Intermediate or Advanced sequences.

RED LION CONTEST RESULTS

On the weekend of October 8-9, IAC Chapter 94 held their Four Category Contest at Red Lion Airport in Vincentown, NJ. There were a total of 45 competitors including 13 from Chapter 35 (*). Clouds and low ceilings delayed the start of flying on Saturday. Fortunately, the weather improved steadily throughout the day. Due to weather delays and the large turnout for this contest, the Sportsman pilots were able to fly only once. The Intermediate, Advanced and Unlimited pilots were able to fly twice. The final standings were as follows:

SPORTSMAN	INTERMEDIATE	ADVANCED	UNLIMITED
1. R. Marshall	1. G. Shaeffer	1. A. Cillarato	1. E. Andrews
2. K. Wicker	2. Jerry Bell *	2. N. Frangesh *	2. M. Cutshaw *
3. C. Kurrella	3. Earle Swan	3. C. Chanclu	3. M. Chapman
5. Art Spillos *	4. C. Ryan *	5. M. Goulian *	
10. Ted Barnard *	7. J. Thompson *		
11. P. Goyette *	9. P. Voegtlin *		
12. Augie Bohn *	12. Roy Heays *		
15. Ed Morse *			

=====

1988 MEMBER SURVEY RESULTS

Forty members responded to the 1988 Member Survey Questionnaire. Complete results are attached. When looking at the results, you may notice anomalies in the total number of answers received for certain questions. This was caused by the fact that some people did not answer all of the questions.

Of the people who responded to the questionnaire, 88% own aerobatic airplanes while only 53% have flown in an IAC contest. Approximately 71% of the people who have not flown in an IAC contest are planning to do so in the future. Although about half of the respondents have attended an IAC Judge's school in the past, three quarters expressed interest in attending the Chapter 35 Judge's school tentatively scheduled for March of 1989.

The officers of the chapter wish to thank all of you who took the time to fill out and return the questionnaire. We received many good comments and suggestions and we are planning to act upon as many of them as possible.

JUDGE'S SCHOOL SCHEDULED FOR MARCH 1989

In response to the interest expressed by those members who responded to the Member Survey, Chapter 35 is planning to hold an IAC Judge's School in March 1989. As you know, IAC will be adopting the revised Aresti Manual for the 1989 contest season and all judge's will be required to attend a judge's school. The figure numbers and K factors for most maneuvers have been revised and several new figures have been added and some old ones have been deleted. As a result, all competition pilots will be required to revise their free sequences in accordance with the new manual. If you are planning to fly competition in any category in 1989, you should attend the judge's school. The exact date and location of the judge's school will be published in the newsletter and in SPORT AEROBATICS as soon as we have the arrangements finalized.

IAC REGIONAL MEETING SCHEDULED FOR 29 OCTOBER 88

IAC plans to hold its first fully organized IAC Regional Meeting on Saturday, 29 October 1988 at 10:00 AM. The meeting will be held at the Day's Inn in Newark, New Jersey.

IAC President Mike Heuer and Vice President John Gardner will be there to talk to all of you in person, answer your questions, discuss important news facing the sport aerobatic world, and to address any controversies or problems that you might like to talk about. For further information, contact any of the chapter officers or Art Bianconi, 983 Madison Avenue, Plainfield, NJ 07060, 201-757-9573.

=====

NOMINATIONS FOR 1989 CHAPTER OFFICERS STILL OPEN

Nominations are still open for the 1989 Chapter elections. We are looking for candidates to run for the offices of president, vice president, secretary, treasurer, and newsletter editor. Nominations may be made in person at the October meeting or by mail using the nomination form at the bottom of this page. Nomination forms should be mailed to our Treasurer, Ken Voegtlin.

Candidates for office must be members of the Chapter, IAC and EAA. Fortunately, there will be no televised debates. Candidates, campaign chairmen and spin merchants wishing to place political advertisements in the monthly newsletter may do so at the rate of \$100 per word. Payment must be made in advance and in cash. We do not accept checks, credit cards or issue receipts.

The nomination period will close at the end of the October meeting. All persons nominated for office will be contacted to assure that they agree with having their names placed on the ballot. The slate of candidates for 1989 Chapter offices will be announced as soon as possible following the October meeting.

Balloting will be conducted by mail. Ballots will be sent to all current Chapter members before the end of October. Ballots will be opened and counted at the at the November meeting. Winners will not be allowed to ask for a recount. The 1989 officers will take office in January 1989.

(CUT ALONG DOTTED LINE)

NEW ENGLAND AEROBATIC CLUB
 IAC CHAPTER 35
 NOMINATION FORM FOR 1989 CHAPTER ELECTIONS

President: _____

Vice President: _____

Secretary: _____

Treasurer: _____

Newsletter Editor: _____

MAIL TO: Ken Voegtlin
 PO Box 479
 W. Ossipee, NH 03890

=====

1988 DUES

If the symbol "\$\$\$" appears below and to the left of the mailing label on your copy of this newsletter, our records show that we have not yet received your 1988 dues.

If you are a potential new member, we will keep you on the mailing list for three months while waiting for your check. Please send your check for \$5 to our Treasurer, Ken Voegtlin, at PO Box 479, W. Ossipee, NH 03890.

IAC 35 CONTACT LIST

If you have any questions, suggestions, items for the "FOR SALE" or "CALENDAR OF EVENTS" columns, etc., please feel free to contact any of the chapter officers whose names, addresses and phone numbers are listed below:

- President: Neal Frangesh, 399 North St, Duxbury, MA 02332 617-834-7771
- Vice Pres: Augle Bohn, RFD 1, Box 691, Hancock, NH 03449 603-525-3545
- Treasurer: Ken Voegtlin, PO Box 479, W. Ossipee, NH 03890 603-323-7883

FOR SALE

- 1976 DECATHALON: 180 HP, heavy crank, Ken Grant, 603-362-4848
- 1975 CITABRIA 7ECA: 115 HP, 780 TTSN, KX155 Navcom, KT76A Xponder, Hamilton vertical card compass, 5 point harness, auto fuel STC, \$18,000, Bill Kelley, Home: 401-738-5745, Work: 401-331-1771

CALENDAR OF EVENTS

- Oct 22 IAC 35 meeting, Jaffrey, NH
- Nov 19 IAC 35 meeting, Nashua, NH
- Feb 1989 Annual Awards Banquet
- Mar 1989 Judge's School
- Sep 1989 New England Aerobatic Championships

NEW ENGLAND AEROBATIC CLUB

INTERNATIONAL AEROBATIC CLUB CHAPTER 35

RESULTS OF 1988 IAC 35 MEMBER SURVEY

NAME:		
ADDRESS:		
CITY:	STATE:	ZIP:
HOME PHONE:	WORK PHONE:	
1. Are you a member of IAC?	38 Yes	1 No
2. Are you a member of EAA?	39 Yes	1 No
3. Do you have a pilots license?	38 Yes	2 No
4. If you have a pilots license, please indicate current rating.	0 Student	16 Private
	15 Comercial	7 ATP
5. Do you fly aerobatics?	35 Yes	5 No
6. Do you own an aerobatic airplane?	29 Yes	11 No
7. Do you rent an aerobatic airplane?	5 Yes	32 No
8. Do you own a non-aerobatic airplane?	13 Yes	25 No
9. Have you ever flown in an IAC contest?	21 Yes	19 No
10. If you have flown in an IAC contest, please indicate highest category flown.	0 Basic	9 Sportsman
	5 Intermed	4 Advanced
	3 Unlimited	
11. If you have not flown in an IAC contest, do you plan to do so in the future?	12 Yes	5 No
12. Do you think IAC and/or Chapter 35 place too much emphasis on competition?	3 Yes	36 No
13. Do you think IAC and/or Chapter 35 is too involved with supporting the US Aerobatic Team?	5 Yes	32 No
14. Do you think IAC and/or Chapter 35 needs to have more activities that are not related to competition flying?	8 Yes	24 No
15. Have you ever attended an IAC Judges School?	19 Yes	21 No
16. If Chapter 35 holds a judges school in the first quarter of 1989, are you interested in attending?	28 Yes	10 No
17. Are you an IAC Judge?	7 Yes	33 No
18. If you are an IAC Judge, please indicate rating.	4 Regional	3 National
19. Is the mailing address on your newsletter correct?	33 Yes	7 No
20. Comments, sugestions, complaints?	21 Yes	19 No
<p>I never have enough money. Lets have more flying and less talk at the meetings. I can't seem to make the meetings. Lets try mock combat. Where do I stay in Jaffery? Lets have a judge's school. Cash prizes for the contest. It's too hard to obtain and maintain a judge's rating. More time should be spent on flying technique at the meetings. My new airplane will be ready soon. Golf shirts with the Chapter 35 logo. And more.....</p>		

NEW ENGLAND AEROBATIC CLUB
399 NORTH STREET
DUXBURY, MA 02332



MR. VAL BEAUDRAULT
RR 1, BOX 1240
WEARE, NH 03281

NEW ENGLAND AEROBATIC CLUB

INTERNATIONAL AEROBATIC CLUB CHAPTER 35

NOVEMBER 1988 NEWSLETTER

NOVEMBER MEETING -----

The November meeting will be held on SATURDAY, NOVEMBER 19, at Daniel Webster College, Nashua Airport Tower Building at 10:00 AM, rain or shine. At this meeting, there will have a discussion of the 1989 Known Sequences (copies attached), the new FAI (Aresti) Catalog and the IAC Regional meeting recently held in Newark, NJ.

If you are planning to fly to the meeting, be advised that Nashua now has a control tower. The tower is in operation from 8:00 AM to 6:00 PM. Aircraft inbound for landing should contact the tower on 119.7 prior to entering the Airport Traffic Area for instructions on pattern entry. The ground control frequency is 121.8. ATIS will be available in the future.

Complete details are given in FAA LETTER TO AIRMEN NO. 88-1. You may also wish to review Chapter 4, Section 3, Paragraphs 220 through 259, of the AIRMEN'S INFORMATION MANUAL covering Airport Operations. Please be on your best behavior. Downwind legs should be flown in normal upright flight.....

NOTES ON THE LAST MEETING -----

The September meeting was held on Saturday, October 22, at Silver Ranch Airpark (Jaffrey Airport) in Jaffrey. Ten members were present. The weather was IFR so we were unable to do any practice flying.

CHRISTMAS VACATION -----

Please note that there will be no Newsletter or meeting in December. The Newsletter will resume publication in January. The January meeting will be held on SATURDAY, JANUARY 21, at Daniel Webster College, Nashua Airport Tower Building at 10:00 AM.

1989 KNOWN SEQUENCES -----

The final 1989 Known sequences for the Sportsman, Advanced and Intermediate categories were adopted at the 20 October 88 IAC Board Meeting. Advance copies, received from Liza Weaver, are attached. These sequences are significantly different than the preliminary ones published in the September issue of SPORT AEROBATICS. There will be a discussion of these sequences at the November meeting.

=====

CHAPTER 35 ELECTION RESULTS

The nomination process for 1989 chapter officers produced a slate of unopposed candidates thus sparing the membership the usual ordeal of listening to the usual campaign rhetoric about lower taxes, greater benefits and balanced budgets. The 1989 officers will be:

President:	Neal Frangesh
Vice President:	Augie Bohn
Secretary:	Ed Morse
Treasurer:	Ken Voegtlin
Newsletter Editor:	(STILL OPEN)

Also nominated for office but declining to run were Erik Fleming for President, Paul Voegtlin for Vice President, Priscilla Beaudrault for Secretary and Ward Bryant for Newsletter Editor.

ANNUAL AWARDS BANQUET SET FOR FEBRUARY 18, 1989

Mark your calendars now! The 1989 ANNUAL AWARDS BANQUET will be held on SATURDAY, FEBRUARY 18, 1989 at the Ninety Nine Restaurant in Nashua, NH. Complete details will be published in this newsletter as soon as we have finalized the arrangements.

IAC 35 JUDGE'S SCHOOL SCHEDULED FOR MARCH 1989

In response to the interest expressed by the membership in 1988 Member Survey, IAC Chapter 35 is planning to hold an IAC Judge's School in 1989. The date has been tentatively set for the weekend of In March 18-19. Chapter member Bill Fletcher, president of Termiflex Corporation, has graciously agreed to allow us to hold the school at their facility in Nashua, NH. Complete details will be published in this newsletter as soon as we have the arrangements finalized.

1989 DUES

The Chapter dues for 1989 have been raised to \$10. This increase in dues, the first since the Chapter was started in 1973, is necessary to cover our monthly operating expenses. Please note that even at \$10 per year, Chapter 35's dues remain lower than those for any other similar organization.

Our largest recurring monthly expenditure is postage for and reproduction of the Newsletter. The Chapter sends out approximately 100 Newsletters per month at a cost of about \$75 per month. In other words, the 10 newsletters you receive each year cost the Chapter approximately \$7.50.

=====

If the symbol "\$\$\$" appears below and to the left of the mailing label on your copy of this newsletter, our records show that we have not yet received your 1989 dues. Please send your check for \$10 to our Treasurer, Ken Voegtlin, at PO Box 479, W. Ossipee, NH 03890.

LIZA WEAVER APPOINTED TO IAC BOARD OF DIRECTORS

Liza Weaver of IAC Chapter 94 has been appointed to the IAC Board of Directors to fill the vacancy created by John Gardner's election to Vice President of IAC and is now Chapter 35's Area Representative. Liza has asked us to advise our members that she can be reached at 122 Himmelein Road, Medford, NJ 08055, 609-654-7867.

If you have any problems or suggestions that need to be brought to the attention of IAC Headquarters or the IAC Board of Directors, please feel free to contact Liza directly.

SEBRING CONTEST RESULTS

On the weekend of October 20-22, IAC Chapter 23 held their Four Category Contest at Sebring, Florida. Among the competitors were 2 from Chapter 35 (*), Erik Fleming and Mike Goullan. Erik and Mike reported that the weather was near perfect. The final standings were as follows:

SPORTSMAN	INTERMEDIATE	ADVANCED	UNLIMITED
-----	-----	-----	-----
1. S. Finnigan	1. E. Fleming *	1. Phil Knight	1. C. McHenry
2. John Massey	2. W. Williamson	2. Mike Mays	2. J. O'Connell
3. Phil Winkler	3. R. Penteado	3. Brian Becker	3. J. Lillburgh
		4. M. Goullan *	

IAC 35 CONTACT LIST

If you have any questions, suggestions, items for the "FOR SALE" or "CALENDAR OF EVENTS" columns, etc., please feel free to contact any of the chapter officers whose names, addresses and phone numbers are listed below:

- President: Neal Frangesh, 399 North St, Duxbury, MA 02332 617-834-7771
- Vice Pres: Augie Bohn, RFD 1, Box 691, Hancock, NH 03449 603-525-3545
- Secretary: Ed Morse, 24 Greenwich Road, Norwood, MA 02062 617-762-5720
- Treasurer: Ken Voegtlin, PO Box 479, W. Ossipee, NH 03890 603-323-7883

=====

FOR SALE

1976 DECATHALON: 180 HP, heavy crank, Ken Grant, 603-362-4848

1975 CITABRIA 7ECA: 115 HP, 780 TTSN, KX155 Navcom, KT76A Xponder, Hamilton vertical card compass, 5 point harness, auto fuel STC, \$18,000, Bill Kelley, Home: 401-738-5745, Work: 401-331-1771

CALENDAR OF EVENTS

Nov 19 IAC 35 meeting, Nashua, NH

Jan 21 IAC 35 meeting, Nashua, NH

Feb 18 Annual Awards Banquet, Nashua, NH

Mar 18-19 IAC 35 Judge's School, Nashua, NH (TENTATIVE DATE)

Sep 1989 New England Aerobatic Championships (TENTATIVE DATE)

1989 SPOBMAN

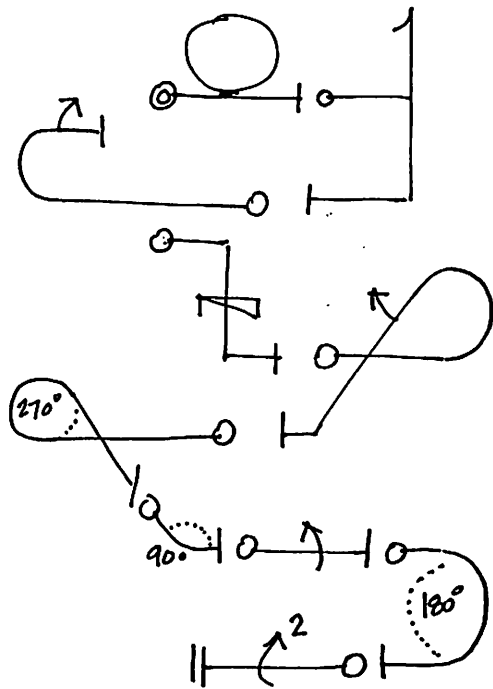

1989 INTERMEDIATE

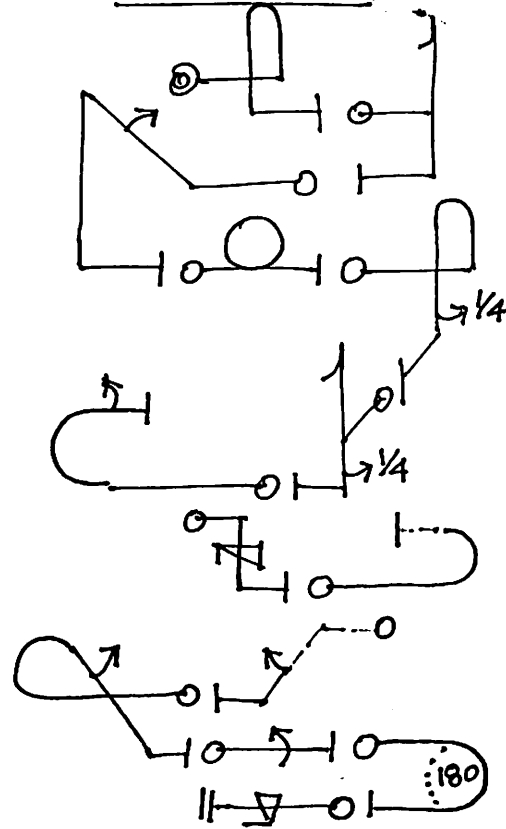

1989 ADVANCED

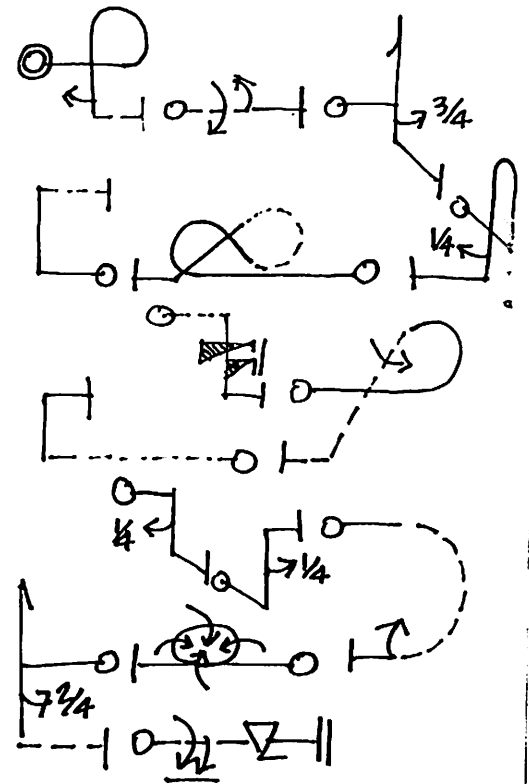

NEW ENGLAND AEROBATIC CLUB
399 NORTH STREET
DUXBURY, MA 02332



MR. VAL BEAUDRAULT
RR 1, BOX 1240
WEARE, NH 03281

\$\$\$



Val - Please look TAGS OVER, I DON'T KNOW ALL OF THE PEOPLE ON THE LIST. THANKS.

NEW ENGLAND AEROBATIC CLUB
DUES LIST: 7 JAN 88

M

<u>LAST NAME</u>	<u>FIRST NAME</u>	<u>MEMBER TYPE</u>	<u>MAILING LIST</u>	<u>88 DUES</u>
	AMMON	ROCKY	R = <i>REGULAR</i>	Y
* ASH	MARK			
ASPELL	SHELDON			
ATLANTIC FLYER	THE	C = <i>COMPONENT</i>	Y	N/A
BARRON	BAILEY			
BARRON	STAN			
BEAUDRAULT	MARLENE	R	Y	Y
BEAUDRAULT	FRISCILLA	R	N	Y
BEAUDRAULT	VAL	R	Y	Y
BELL	JERRY	R	Y	
* BIGOS	JERRY			
BOHN	AUGIE	R	Y	Y
BOHN	RUTH	R	N	Y
* BOICE	PATRICIA			
BOK	HANS	R	Y	
* BRAY	ROBIN			
BROWN	TIM	R	Y	
BRYANT	NORA	R	Y	
BRYANT	WARD	R	Y	
* BUCKLEY	MARTY			
* CARROLL	ROY			
COMMEAU	BOB	R	Y	PD 88 + LINDSEY
* CROWLEY	NED			
CUTSHAW	MICHAEL			PD 88
DENNISON	JACK	<i>C</i>		
DESLAURIERS	ROLAND	R	Y	
DILL	REESE	R	Y	
DUPONT	MIKE	R	Y	
FERRUCCI	JOSEPH	C	Y	N/A
FLAVELL	JACK	R	Y	Y
FLEMING	ERIC	R	Y	
FLETCHER	BILL	R	Y	
FLETCHER	JUDY	R	N	
FRANGESH	NEAL	R	Y	Y
* FREEMAN	DAN			
FULTON	EDGAR	R	Y	
GAGE	GLORIA	R	N	
GAGE	RUSSEL	R	Y	
* GORDON	MILTON			
GOULIAN	MICHAEL	R	Y	
GOYETTE	PAUL	C	Y	N/A
GRANT	CAROL	R	N	
GRANT	KEN	R	Y	
* GRAVES	GORDON			
HAMER	LINDA	C	Y	N/A
HARDY	JEAN	R	Y	
HEAYS	ROYDEN	C	Y	N/A
HEUER	MIKE	C	Y	N/A
HOWELL	HARVEY	R	Y	Y
* JENACK	BRUCE			
* KELLER	JOHN			

NEW ENGLAND AEROBATIC CLUB
DUES LIST: 7 JAN 88

<u>LAST NAME</u>	<u>FIRST NAME</u>	<u>MEMBER TYPE</u>	<u>MAILING LIST</u>	<u>88 DUES</u>
* KELLY	WILLIAM			
* LAMPREY, JR.	ROBERT			
LARSEN	CHUCK	C	Y	N/A
MAGUIRE	JIM	R	Y	
* MAHARAJ	KEN			
* MAJERCIK	DONALD			
MAYNARD	ART	R	Y	Y
MORGAN	GINA			
MORGAN	JACK			
MORIN	DON	R	Y	
MORSE	ED	R	Y	
MORSE	MADELINE	R	N	
MOXTER	BOB	R	Y	
MOXTER	LORY	R	N	
* MURPHY	JOHN			
NESIN	ASH	R	Y	
NESIN	SALLIE	R	N	
* PHILLIPS	SCOTT			
* PLOUFFE	RICHARD			
* PRINCINCE	KENNETH			
* RAMSEY	ROY	R	Y	
* ROWELL	DAVE	R	Y	
* RUGGLES	DENNIS	R	Y	
* RUNNELS	RICK	R	Y	
RYAN	CHARLIE	R	Y	Y
* SAWYER	DENNIS	R	Y	
SAWYER	HARVEY	C	Y	N/A
SAWYER	LEE	C	N	N/A
* SCANLON	JACK			
SCHAUSS	DICK	C	Y	N/A
* SCONCE	BILL	R	Y	
* SKUPIEN	DARLENE	R	N	
* SKUPIEN	STEVE	R	Y	
* SPILIOS	ARTHUR	R	Y	
STANTON	JIM	R	Y	PD 88
* STOOPS	DON			
* STOOPS	MARIE			
STORY	LEON	R	Y	Y
* STUART	BILL	R	Y	
* TELLER	TOM	R	Y	
* TIEDT	TOM			
TRUDEAU	MARC			PD 88
* VAN OSS	LEE			
* VLAHAKIS	DINO			
VOEGLIN	JOANNE	R	N	
* VOEGLIN	KEN	R	Y	
* VOEGLIN	PAUL	R	Y	
* WATKINS	JOHN	R	Y	
WEAVER	LIZA	C	Y	N/A
* WILSON	LEE			
* YATES	CHARLIE	R	Y	

NEW ENGLAND AEROBATIC CLUB
DUES LIST: 7 JAN 88

<u>LAST NAME</u>	<u>FIRST NAME</u>	<u>MEMBER TYPE</u>	<u>MAILING LIST</u>	<u>88 DUES</u>
ZILS	MELISSA	R	Y	Y
ZLOTEK	DAVID	C		

Count: 104
