

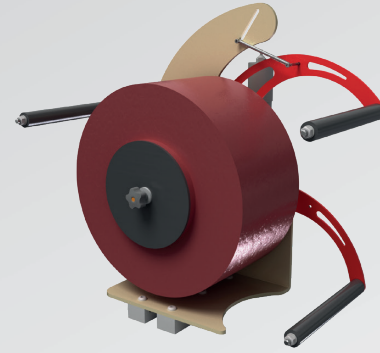

RAP STRIP

Applicatore nastro a strappo "RAP STRIP"
Applicator of tear tape "RAP STRIP"

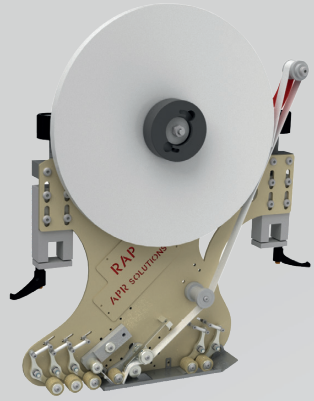

RAP
Applicatore nastro biadesivo "RAP"
Applicator of double-sided tape "RAP"

*Poster
Posters

*Campionari Tessuti
Tissue samples

*Buste
Envelopes

*Sacchetti
Bags

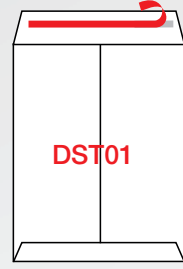
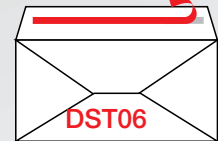
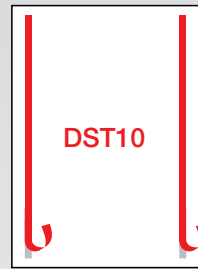
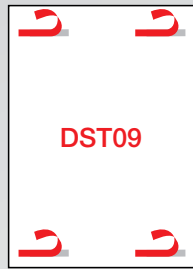

*Portaritratti per foto
Picture frames

Fustino detersivo con tear-tape
Detergent pail with tear-tape

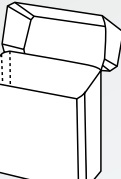
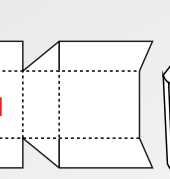
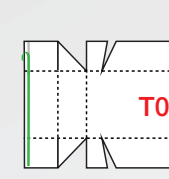
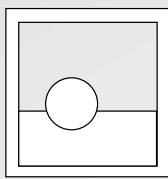
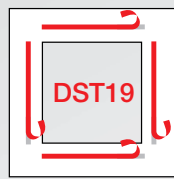

*Prodotti realizzabili con gli opzionali su richiesta.
Products achievable with the optionals on request

INSERTER

FEEDER AUTOMATICO, per l'alimentazione di pieghevoli farmaceutici, libretti, prodotti in bustina, depliant, cartoncini ecc ... da inserire in linee di produzione e confezionamento.

INSERTER

AUTOMATIC INSERTER, inserting a large variety of products like brochure, book notes, plastic products like cards, and so on, that can be added on any of our automatic machines.

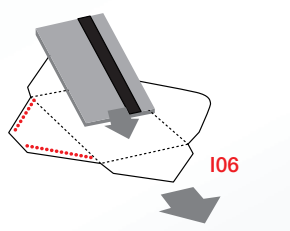
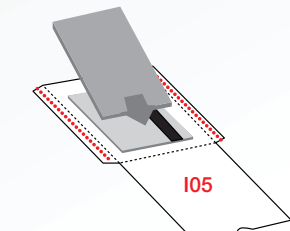
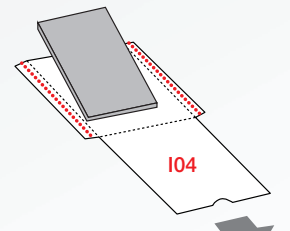
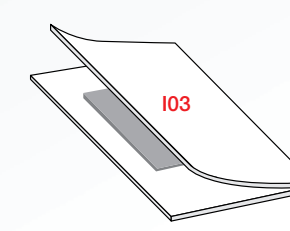
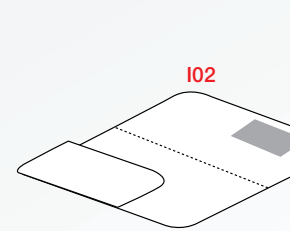
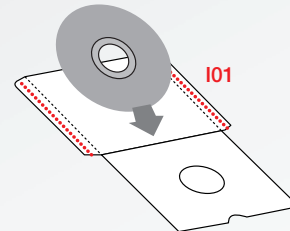
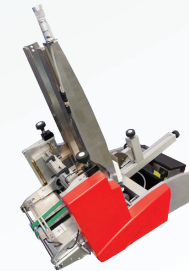

SISTEMA 3D

Sistema speciale capace di convertire la piega bi-dimensionale in una piega tri-dimensionale, permettendo la produzione di cartelline di presentazione, buste, etc. con dorso.
Capacità dispositivo di piega: tra 5 e 25 mm.

3D SYSTEM

Special forming system able to convert the flat bi-dimensional folding to capacity tri-dimensional folding, enabling to produce presentation folder, envelopes, etc with capacity/spine.
Capacity forming device: from 5 to 25 mm.

*Cartelline con dorso
Capacity folders

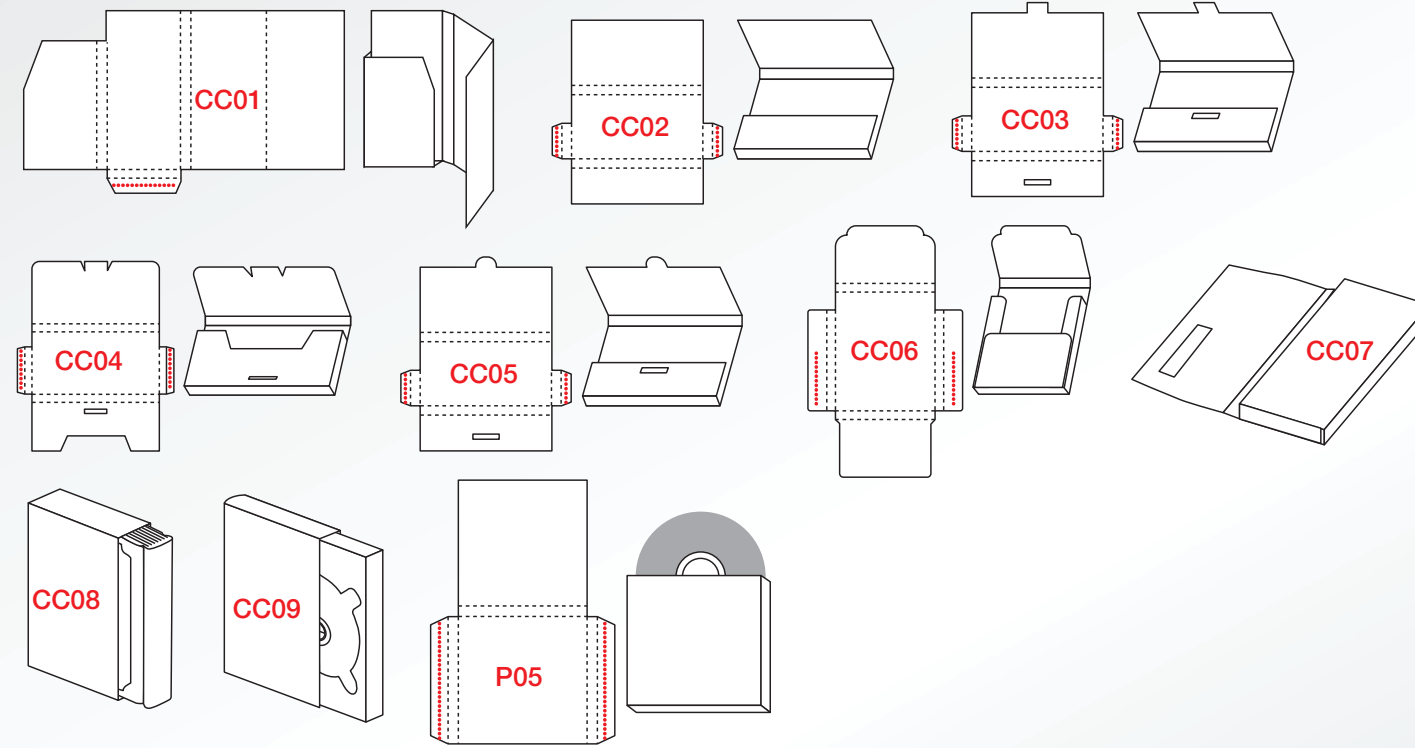

Con riserva di variazioni tecniche. Non ci assumiamo responsabilità per eventuali errori di stampa e dati mercantili o inseriti.
We reserve the right to make technical changes at any time. We do not accept responsibility for any printing errors and missing or incorrect data.

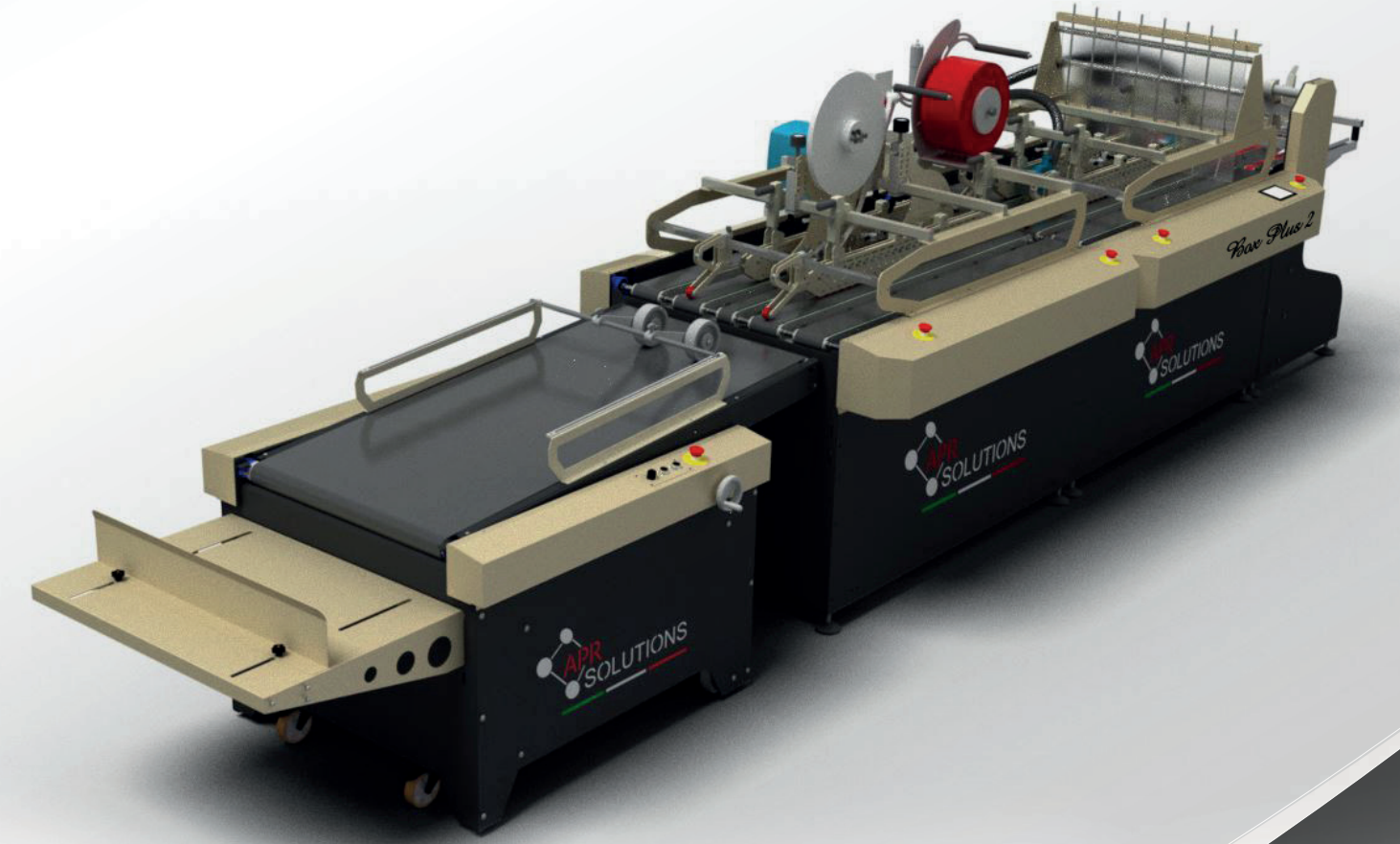

APR Solutions srl
Via Aldo Moro, 10 • 10030 Rondissone TO - Italy
Tel: +39 011 5504469 • Fax: +39 011 5504461
Email: info@aprsolutionsrsl.com • Sito: www.aprsolutionsrsl.com

Box Plus 2

Box Plus 2



MACCHINA PIEGA-INCOLLATRICE BOX PLUS 2

Macchina di nuova costruzione, progettata e realizzata in Italia, creata per la realizzazione di:

1. Astucci lineari
2. Astucci a fondo automatico
3. Cartelline con una o due tasche (opzionale su richiesta - Tipper Plate)
4. Buste e cartelline con soffietto, e cartelline di presentazione (opzionale su richiesta - Tipper Plate)
5. Buste porta CD/DVD con una o due tasche (opzionale su richiesta - Tipper Plate)
6. Buste da 12*15 cm fino a 70*100 cm formato aperto (opzionale su richiesta - Tipper Plate)
7. Buste per referti medici, buste speciali (opzionale su richiesta - Tipper Plate)
8. Applicazione di nastro biadesivo (opzionale su richiesta - Rap)
9. Buste da corriere (DHL, FedEx, TNT, etc.) con nastro biadesivo e tear tape (opzionale su richiesta - RAP Strip)
10. Macchina predisposta all'aggiunta di un inserter (opzionale su richiesta - Inserter)
11. Cartelline e buste con dorso (opzionale su richiesta - Sistema 3D)
12. Incollatura a freddo (opzionale su richiesta)
13. Possibilità di incollaggio contemporaneo verticale e orizzontale
14. Lettore codice a barre (opzionale su richiesta)
15. HP Inkjet (opzionale su richiesta)
16. Lettore alfabeto Braille

Aggiungendo il sistema di rotazione su richiesta, una varietà di applicazioni complesse possono essere realizzate in un unico passaggio

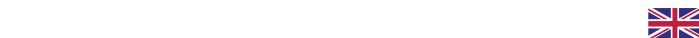
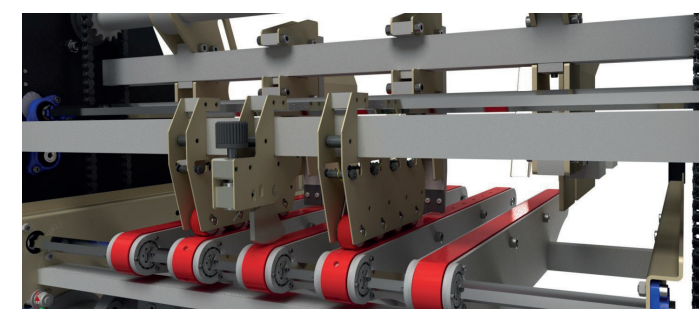

BOX PLUS 2 FOLDER-GLUER MACHINE

New construction machine, made in Italy, designed for the production of:

1. Straight-line boxes
2. Crash-lock bottom boxes
3. Folders with one or two pockets (optional on request - Tipper plate)
4. Envelopes and Folders with gussets, and presentation folders with large document pockets (optional on request - Tipper plate)
5. Covers for DVD envelopes with one or two pockets (optional on request - Tipper plate)
6. Envelopes form 12*15 open size up to 70*100 cm. (optional on request - Tipper plate)
7. Medical file envelopes, special size envelopes. (optional on request - Tipper plate)
8. Application of double-sided tape on blanket (Optional on Request - Rap)
9. Courier Envelopes (DHL, FedEx, TNT, etc.) with double-sided tape & tear tape (Optional on request-Rap Strip)
10. Machine ready to add inserter tape (Optional on request-Inserter)
11. Folders and envelopes with Capacity (Optional on request- 3D system)
12. Cold melt system (optional on request)
13. Possibility of contemporaneous vertical and horizontal gluing
14. Bar code reader (optional on request)
15. HP Inkjet (optional on request)
16. Braille alphabet reader (optional on request)

By adding the rotation units on request, many complex applications can be done in one step.

Doppio sistema di trasporto carta .
 Dual transport system.

Macchina Box Plus 2 Standard Box Plus 2 Standard Machine

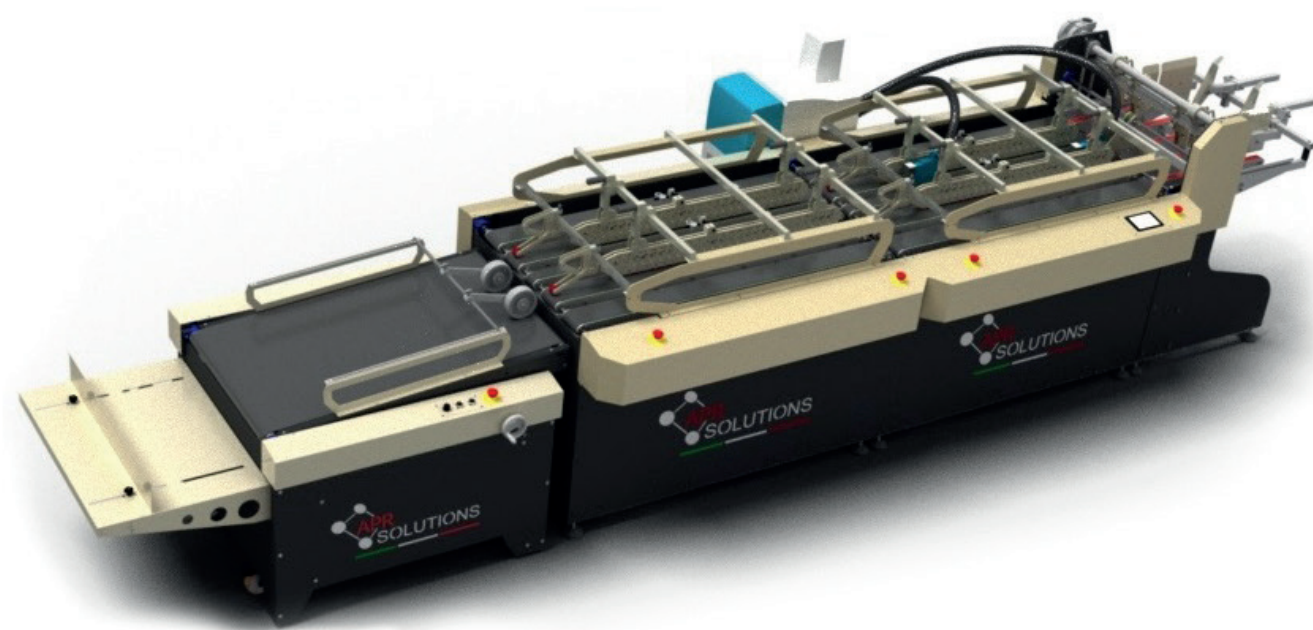

Caratteristiche tecniche	
Formato di introduzione	Min 100 x 100 mm Max 700 x 1020 mm
Grammatura carta	Min 200 g/m ² Max 600 g/m ²

Technical Characteristics	
Introduction format	Min 100 x 100 mm Max 700 x 1020 mm
Paper weight	Min 200 g/m ² Max 600 g/m ²

Prodotti realizzabili con la macchina Box Plus 2 Products achievable with the Box Plus 2 machine

Astucci Lineare i e a fondo automatico
Linear and crash lock bottom boxes

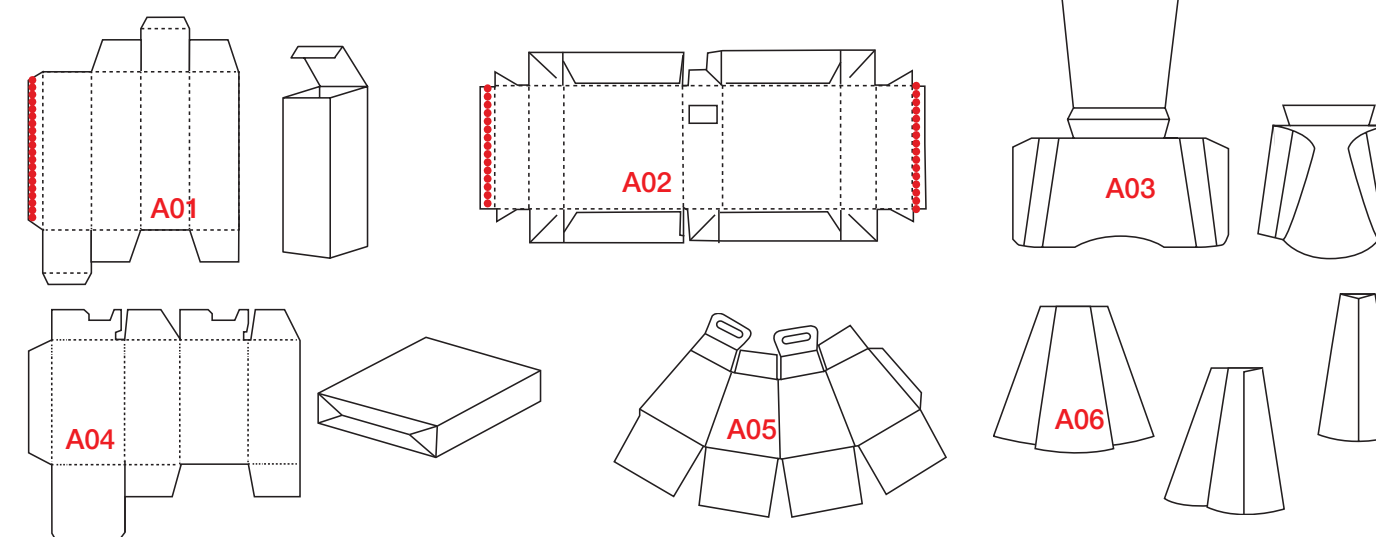

Opzionali su richiesta Optionals on request

Tipper Plate Tipper Plate

Box Plus 2 è dotata di Tipper fold plate, un dispositivo di piega mobile e amovibile, provvisto di scanalature verticali, una lamiera ferma-prodotto orizzontale regolabile in altezza, e un soffiatore. Il Tipper fold plate è azionato attraverso un sistema elettro-pneumatico.

Box Plus 2 is equipped with a movable and detachable tipper fold plate, provided with vertical slots, an adjustable stop plate, and an air pressure blast. The tipper fold plate is operated by an electro-pneumatic system.

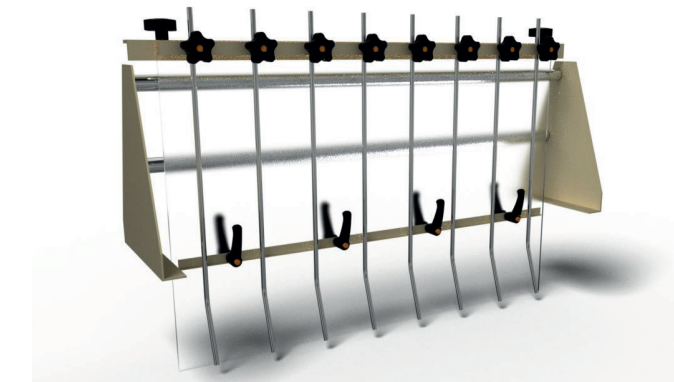

Buste
Envelopes

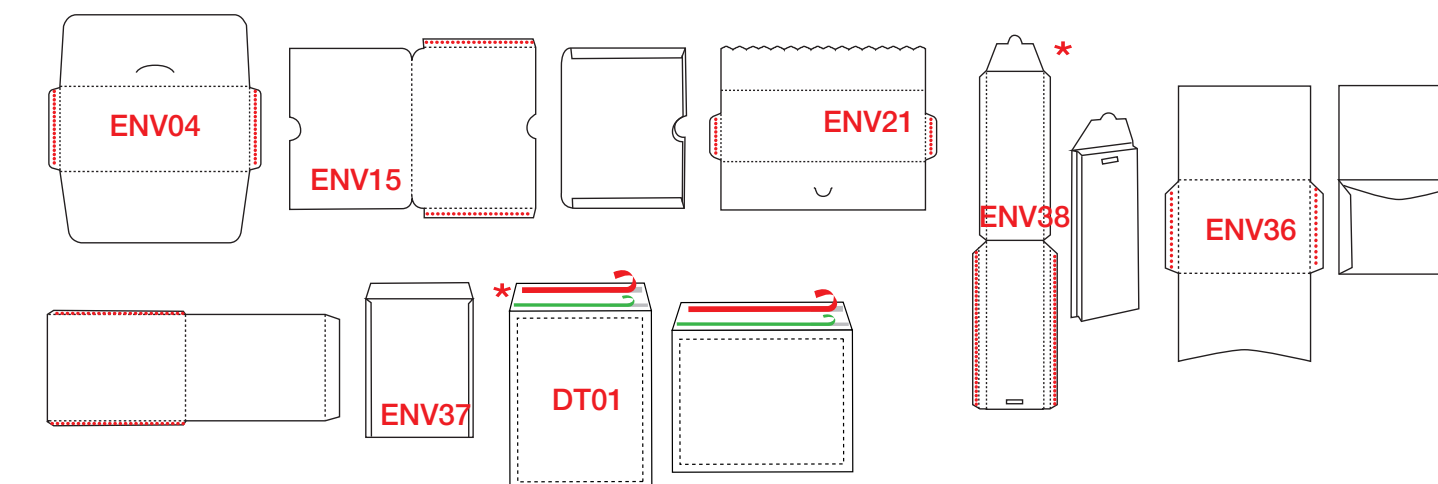

Porta CD/DVD
CD Envelopes

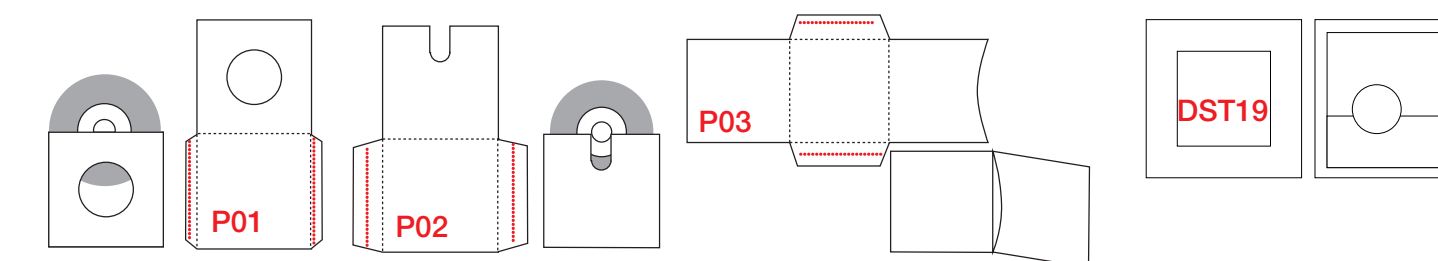

Cartelline con tasche
Folders with pockets

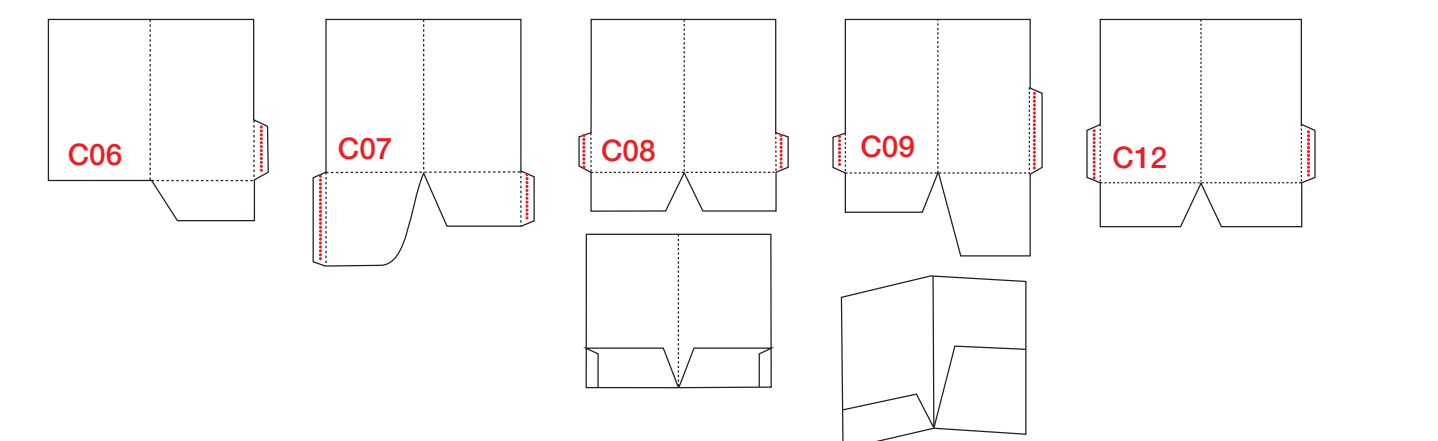

*Portaritratti per foto
Picture frames