

## MINI ATHOS

**Subject: *Mini Athos* - machine designed to apply double-sided tape with semi-automatic feeder, introduction format 500x500 mm, especially for digital market.**

We refer to your inquiry, and are glad to present you our best offer for the supply of machinery for applying double-sided tape. The equipment we offer is produced under exclusive license, trademark "APR SOLUTIONS"



**MINI ATHOS, a "Made in Italy" machine**



**Technical characteristics:**

Format machine introduction	Max 500 x 500 mm
	Min 100 x 100 mm
Tape width (Min-Max)	From 9 mm – 25 mm
Min paper weigh	150 g/m <sup>2</sup>
Max paper weight	800 g/m <sup>2</sup>
Double sided tape materials type	Banner tape, or PVC tape, acrylic tape, Tissue tape, transfer tape.
N. of application	From 1 to 3
Max length tape applicable	999 mm
Min. distance between application and the next in line	25mm
Min. length application of the tape	35mm
Min. distance of the tape from the edge of the paper	10mm
Min. distance of the tape from the edge of the cardboard	0mm
Min. distance between one application and the other in parallel	0mm
Max outer diameter roll tape	480 mm
Internal diameter roll tape	76 mm
Margin of error in application	± 1 mm
Mechanical Speed	40 m/min
Power connection for Rap	Electro Pneumatic
Power connection of the machine	0.38 Kw / 220 V
Machine dimensions	1594 x 758 h 1445mm





- Fix register side system positioned before the Rap applicator for the application of adhesive tape
- The applicator is adjustable in height, and left/right site.
- The setup and programming of the PLC does not require a professional operator, in fact with our touch screen, it would be possible to be used by an operator without experience.
- Mini Athos machine upgradable to add other Rap applicator in parallel.



**Delivery Manual Table**

Collection box with a side alignment for easy delivery of the sheets.

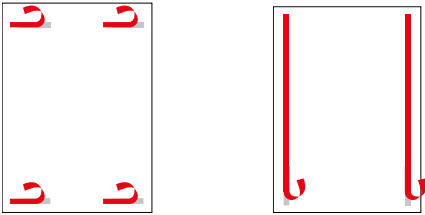
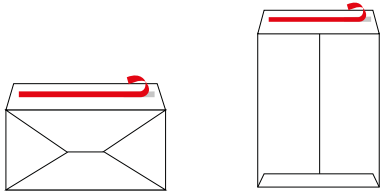
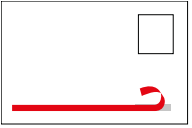
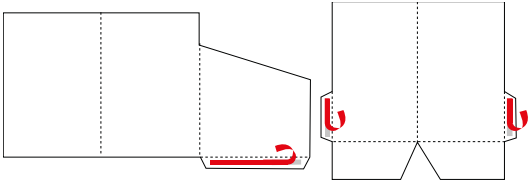
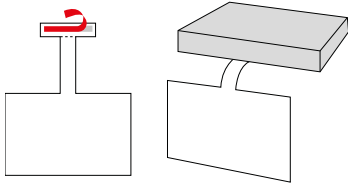
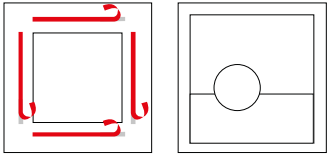
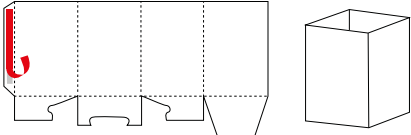
Some products that can be finished with the **MIN ATHOS** machine

POSTERS	ENVELOPES	POSTCARDS
		
FOLDERS	ADVERTISING SIGNS	PHOTO FRAMES
		
BOXES OF POLYPROPYLEN	CALENDARS	
		

**Layout - Mini Athos**



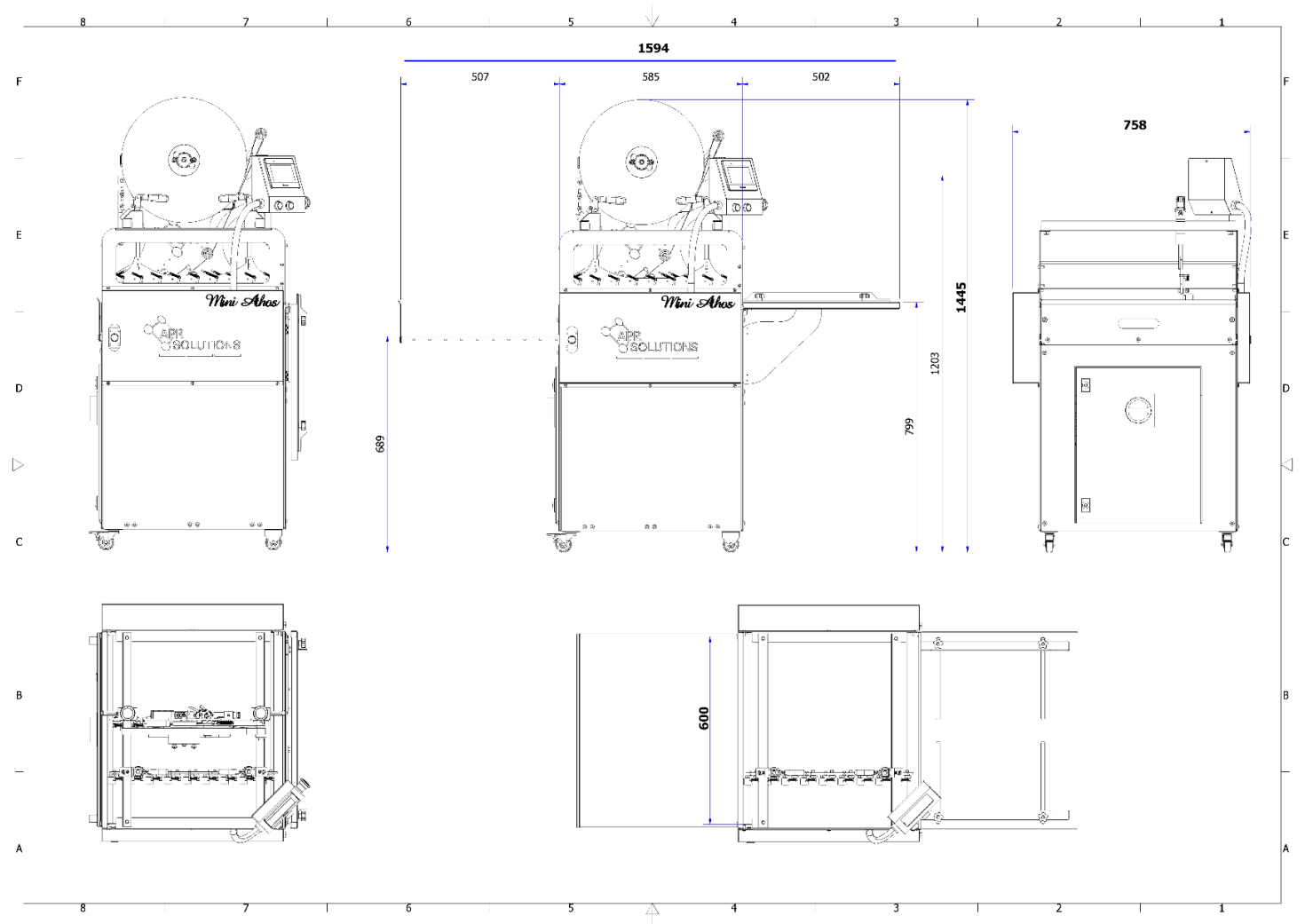

## Sale conditions

Offer valid	<ul style="list-style-type: none"> <li>• 30 Days.</li> </ul>
Terms of delivery:	<ul style="list-style-type: none"> <li>• 45 Days from receiving your confirmation order with the down payment</li> </ul>
Installation:	<ul style="list-style-type: none"> <li>• Specified above: Not Included 400,00 in Europe and 800,00 Euro out of Europe per day for max 3 Days, included travelling days. (transport, room and board at the client's charge). We suggest autonomous installation.</li> </ul>
Terms of Payment:	<ul style="list-style-type: none"> <li>• 30% by confirmation order</li> <li>• 70% before loading by bank transfer.</li> </ul>
Guarantee:	<ul style="list-style-type: none"> <li>• 12 months on defective mechanical parts built by APR Solutions, and 12 months on commercial parts: tapes, belts, chains, rollers, handles, motors, and all electrical parts included plc and touch screen devices.</li> <li>• Delivery of the parts claimed under warranty from our Torino factory while the defective parts must be returned to APR Solutions S.r.l., Italy to inspection.</li> <li>• Warranty does not cover any production loss/penalty suffered by customer due to defective parts, or any other reason.</li> </ul>
Transport & insurance:	<ul style="list-style-type: none"> <li>• Not included.</li> </ul>
Packing:	<ul style="list-style-type: none"> <li>• Specified above.</li> </ul>
<b>Marcatura</b>	<p>All groups are CE marked in compliance with the European machine directive. with the machine will be provided:</p> <ul style="list-style-type: none"> <li>• use and maintenance manual</li> <li>• spare parts manual</li> <li>• wiring diagrams.</li> </ul>
Excluded from the offer:	<ul style="list-style-type: none"> <li>• Exhaust with forklift capacity 2000 Kg</li> <li>• forks length at least 1.2 meters</li> <li>• All compressed air and electric power supplies up to the connection on the machine (minimum pressure required: 6 bar)</li> <li>• Possible building works</li> <li>• The materials for functional tests for training</li> <li>• Anything else not expressly indicated in this offer.</li> </ul>

**IMPORTANT NOTE:** All options or variants to the standard machine, both described and not described in this offer must be requested and quantified before signing the contract. No additions or variations to the agreed upon will be accepted without additional cost increases.



The supply will be regulated by the general supply conditions attached below and forming part of this document.



Stamp and signature of the **VENDOR**

Stamp and signature of the **BUYER**

## GENERAL SUPPLY CONDITIONS

The following conditions will be applied to all contracts with Apr solutions srl. The buyer renounces to applying of any own purchase condition. This document is submitted to the buyer in duplicate copy. The copy countersigned by the buyer will be considered a valid acceptance of the whole proposal. Should any controversy arise concerned with the phraseology and interpretation of this contract, reference must always be made to the original version drawn up in the Italian language.

- 1) **SUBJECT:** The subject of this contract and machine model is defined in the cover of this offer. The technical characteristics as well as the performances and dimensions of the machinery are listed at point "technical description". The buyer's signature to this contract is irrevocable and binding from the moment of signing.
- 2) **PRICE:** The price fixed for the sale is indicated at point "sale conditions". No variations or discounts will be accepted or recognized after this contract is signed.
- 3) **PAYMENT:** The payments are expected to be made always and in all circumstances in cash at the seller's business address, and effected at the moment of delivery of the goods. Any acceptance of bills of exchange or transferred bills or extensions and the issue of drafts on the part of the seller will not constitute departure from the foregoing, but will simply represent a facilitation for the buyer, without modifying either the place or the timing of the payment as established above. Complete observance of the prescriptions concerning the terms and the place for making payments is an essential condition of the contract. Failure to make payment of even a single instalment will occasion the immediate terminations of rights under the contract and will consequently entitle the seller to claim the return of the machine without delay: in such a case, the instalments paid, or the goods received as trade-in against the price, will be considered as acquisitions to the seller as indemnity, not excluding the right to compensation for greater damages. Where, instead, the seller may prefer to demand that the contract be executed in full, without the seller being obliged to declare the buyer in arrears. The paid over accounts will in all cases be considered ascribed to the interest amounts, the expenses connected with the reserved ownership and the stamp duty on the bills of exchange, legal and execution expenses, and lastly the capital sum. In the case of sale and payments through Leasing the seller excludes, in all cases, undertakings with the Leasing company to re-purchase the machine. The seller must receive the Leasing Company's order at least two weeks before the shipment of the machine. Any delay in the receipt of this order could lead to a corresponding postponement of the delivery date according to the seller's unchallengeable decision.
- 4) **DELIVERY:** The delivery date is every case determined with the explicit reservation regarding the possibility of supplying, and is never mandatory nor is it an essential item of the contract. Any delay or failure to deliver within the established term may not in any case be reason for demanding compensation for direct or indirect damage, or in any way be a reason to modify or annul the accepted order. The buyer must ensure that the power connections are provided for, before the equipment is delivered, following the instructions supplied by the seller. In the event that the power connections are not previously arranged, the buyer will be allowed 5 days to provide for them. Should the buyer fail to make these provisions within this further period of time, the guarantee will automatically come into force and the machinery will be considered accepted.
- 5) **TRANSPORT:** It is understood that the buyer is responsible for transportation, unless otherwise specified. In that case the buyer will bear all the associated costs and the responsibility arising for direct or indirect damage due to transportation or to the loading and unloading operations of the machinery. The buyer must therefore insure the transportation and the associated operations with a first-rate insurance company. No responsibility will be assigned to the seller when the buyer provides for it.
- 6) **ASSEMBLY:** The seller will provide exclusively for installation of the machine at buyer premises. The buyer will care for help personnel; building works; electrical, hydraulic, pneumatic, gas connections up to the machine; board and lodging of the buyer technicians during installation; everything else not expressly indicated. The above mentioned connections will be done according to the instructions received from the seller. The seller will not pay for any damage or inconvenience verified before the connection to the machine. Any damage to the machinery generated by external causes, will be reason for guarantees annulment and acceptance of the machinery with consequent obligation for payment without any exception, delay or price reduction.
- 7) **ACCEPTANCE OF THE MACHINERY:** As soon as assembling is completed, the buyer will undertake to prepare and issue the signed report recording the collection and test-run serving as the go-ahead for payment. Alternatively he must specify by registered letter sent within and not more than five (5) days from completion of the assembly the reasons for his failure to subscribe. In the absence of this written contention it will be considered that the machinery has been accepted to all effects with the completion of the machine assembly. Signing the test-run approval or failing to raise objections entails full and definitive acceptance of the machinery. Where the buyer delays the assembling or start-up operations, the delivery note substitutes the signature on the collection record with full effect and the all the buyer's guarantees are lapsed.
- 8) **MATERIALS FOR TESTS:** Unless otherwise specified, it is understood that the materials for the plant's starting-up trials will be supplied freely by the buyer.
- 9) **GUARANTEES:** The machine is guaranteed for the duration of twelve (12) months for the mechanical, electrical and electronic parts. Guarantee period runs from the date of installation of the machinery and is valid only for those buyers who are in order with their payments. The time limit for reporting any defect is fixed at eight (8) days from its discovery. Guarantee is limited to replacement and repair, in the shortest possible time, solely to those items of the machine that are found to be imperfect or defective as material or manufacture. Rubber rollers and all the parts subject to wear are excluded from guarantee. The guarantee does not extend to the mechanical seals of the hydraulic system, to the electrical equipment or in any case to the defects and damage caused by natural wear and tear, unskilled or negligent use on the part of wear and tear, unskilled or negligent use on the part of the buyer, by overloading beyond the predicted limits, by non-authorized interference or tampering or poor maintenance nor yet by casual circumstances or causes of force majeure. The guarantee does not cover machine stops, scrap material, production losses etc. Eventual disputes on the last and extension of guarantee cannot be justification of termination of this contract, of price reduction, of suspension of payments or interruption of guarantee terms.
- 10) **OWNERSHIP RESERVATIONS:** In the case of payment other than Leasing the seller retains the ownership of everything that is supplied until the entire price has been paid, including accessories and expenses; up till this moment the buyer will be responsible for the risks conservation of the goods, including here casual circumstances and those of force majeure, which he is expected to insure against at his own expense with a leading assurance company adopting a policy in favour of the seller; furthermore the buyer is constrained from transferring, pledging or loaning the machinery for use, removing it or having it removed; any such act, before the entire price is paid, being considered an act of bad faith and authorizing the seller in his unquestionable right to declare the contract dissolved by the act and through the fault of the buyer; the seller may reclaim the goods wherever it is found and the buyer will be obliged to declare immediately and telegraphically any action of retention or execution initiated by third parties.
- 11) **SUSPENSION AND ANNULMENT:** The seller may suspend or annul this confirmation, furnishing the buyer with a written communication of the same for that part or parts executed and still to be executed, in the event of any mutation of the juridical or commercial or proprietary situation of the buyer and of non-payments or delays in payment for other supplies, even those concerned with another contract, either for reasons under the guarantee or for each and any other obligation.
- 12) **EXPENSES AND TAXES:** All expenses, duties and taxes, present and future and without exception, consequent on this contract are chargeable exclusively to the buyer.
- 13) **SUBSEQUENT AGREEMENTS:** The seller disavows any agreements in conflict with this contract whensoever there is no written document undersigned by both parties.

APR Solutions srl

Via Aldo Moro n.10 • 10030 Rondissone TO - Italy

Tel.: +39 011 9182026 • Fax: +39 011 9182685

Email: [info@aprsolutions.com](mailto:info@aprsolutions.com) • Sito: [www.aprsolutions.com](http://www.aprsolutions.com)

Codice Fiscale • Partita IVA 11272840015

REA TO – 1200188 • Cap. Soc. € 10.000,00 Int. Vers.





14) TERMINATION: All the clauses inserted in this contract should be considered essential and therefore the disregard on the buyer's part of any one or part of any one of them, will constitute a reason for termination of the contract according to the seller's indisputable judgement .

15) PLACE OF JURISDICTION: The buyer accepts the exclusive and obligatory competence of the Cremona (ITALY) Law Court for any lawsuit connected with this contract whether for reasons under the guarantee or for each and any other liability.

16) COMPETENT COURT: For whatever inherent controversy to the contracted present, the buyer recognizes the exclusive competence and inderogabile of the Court of Cremona - Italy.

Cremona

Italy

After a second reading of this contract the buyer confirms clear acceptance of points from 1 to 16.

THE BUYER Stamp and signature of his legal representative .....

