

SHOWMANSHIP

CLASS #6 - Mini/Pony All Ages & All Walk-Trot Classes: #7, 8, & 9

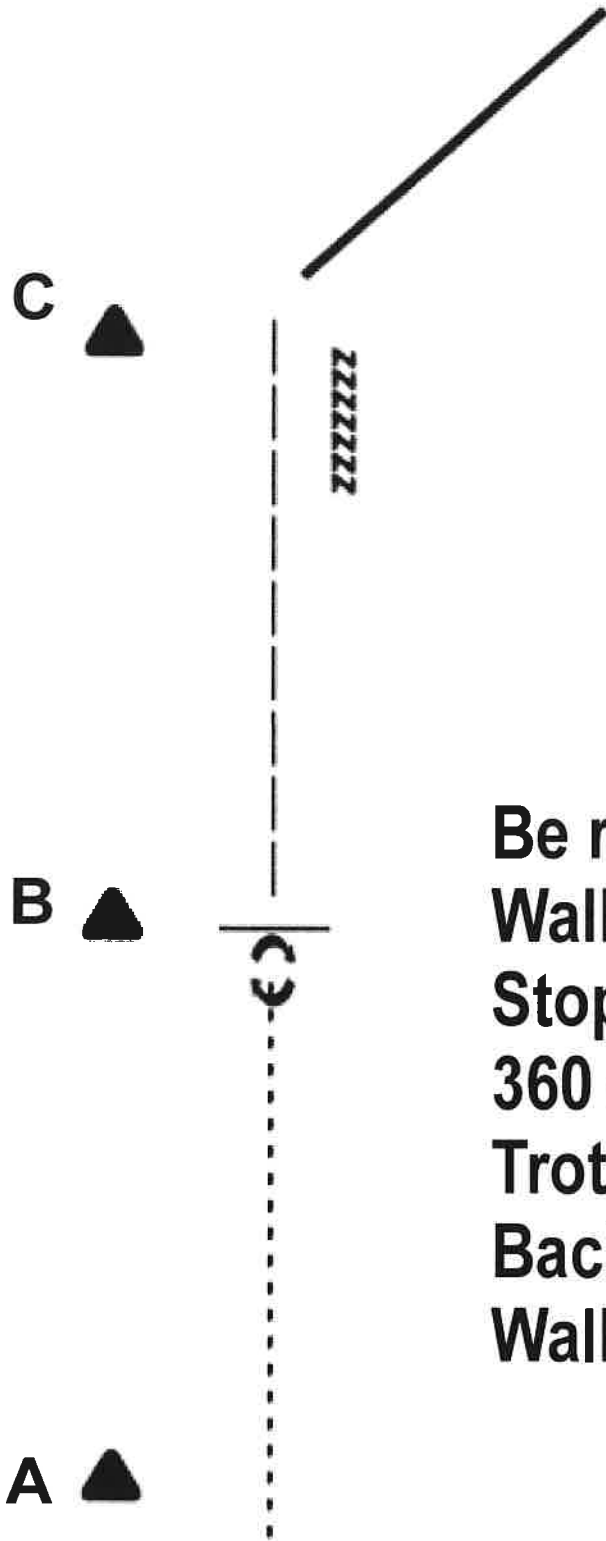

Be ready at marker A
Walk to judge (marker B)
Stop & set up for inspection
360 degree turn to the right
Trot to marker C
Back 5 steps
Walk to line up

SHOWMANSHIP

18 & Under, Novice, 19 & Over & Open

CLASS #'s: 10, 11, 12 & 13

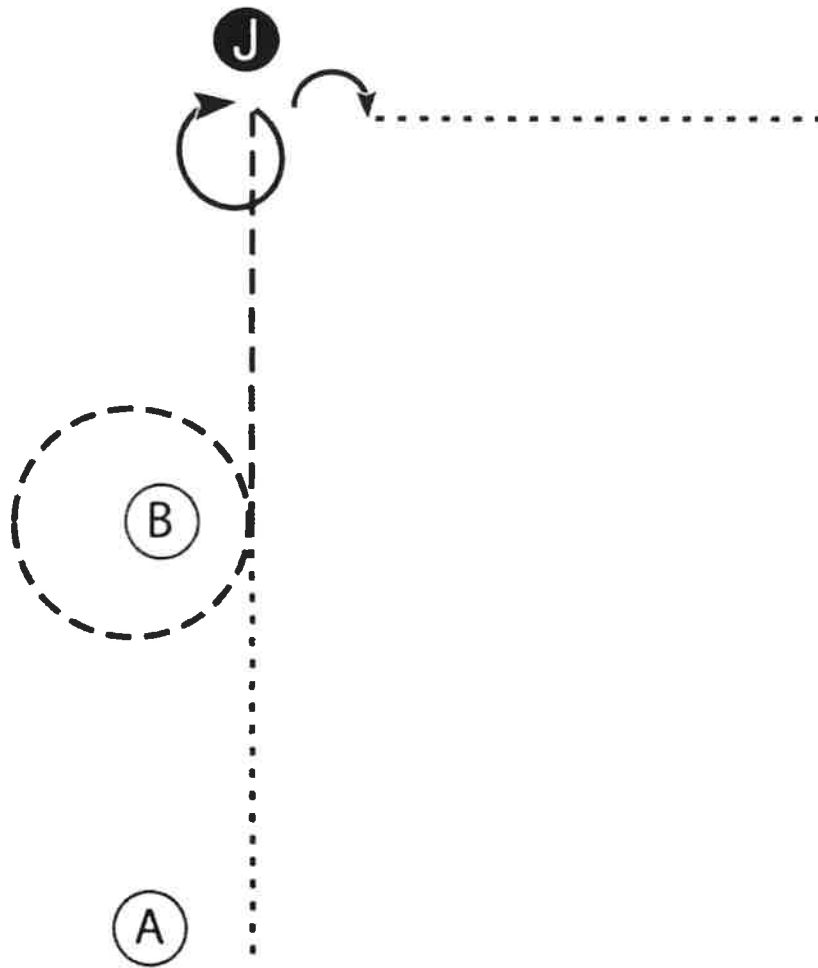

1. Walk from A to B.
2. At B trot. Trot a circle around B and continue to the Judge.
3. Stop and perform a 360 degree turn. Set up for inspection.
4. When dismissed perform a 90 degree turn.
5. Walk straight away from the Judge.

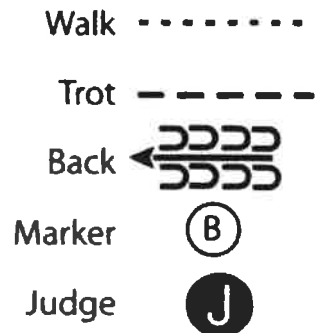

ENGLISH EQUITATION

WALK-TROT - CLASS #30a

with Pattern

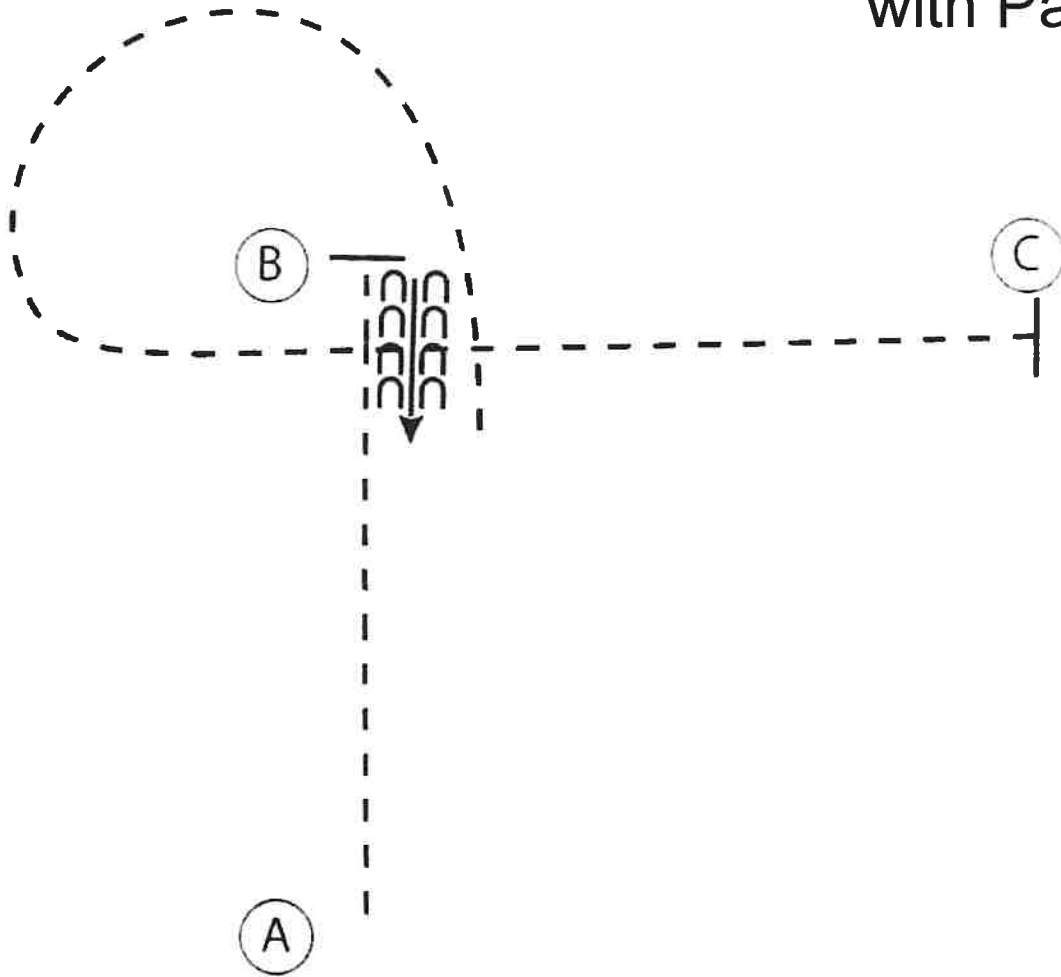

1. Trot A to B
2. At B stop and back 4 steps
3. Trot a circle around B and continue to C
4. Stop at C

Walk
Trot	-----
Extended Trot	-----
Canter	—————
Leg Yield	
Lead Change	↘
Back	←←←←
Marker	(B)
Sidepass	←←←←

ENGLISH EQUITATION

OPEN with PATTERN - CLASS # 30

3 Gaited Division

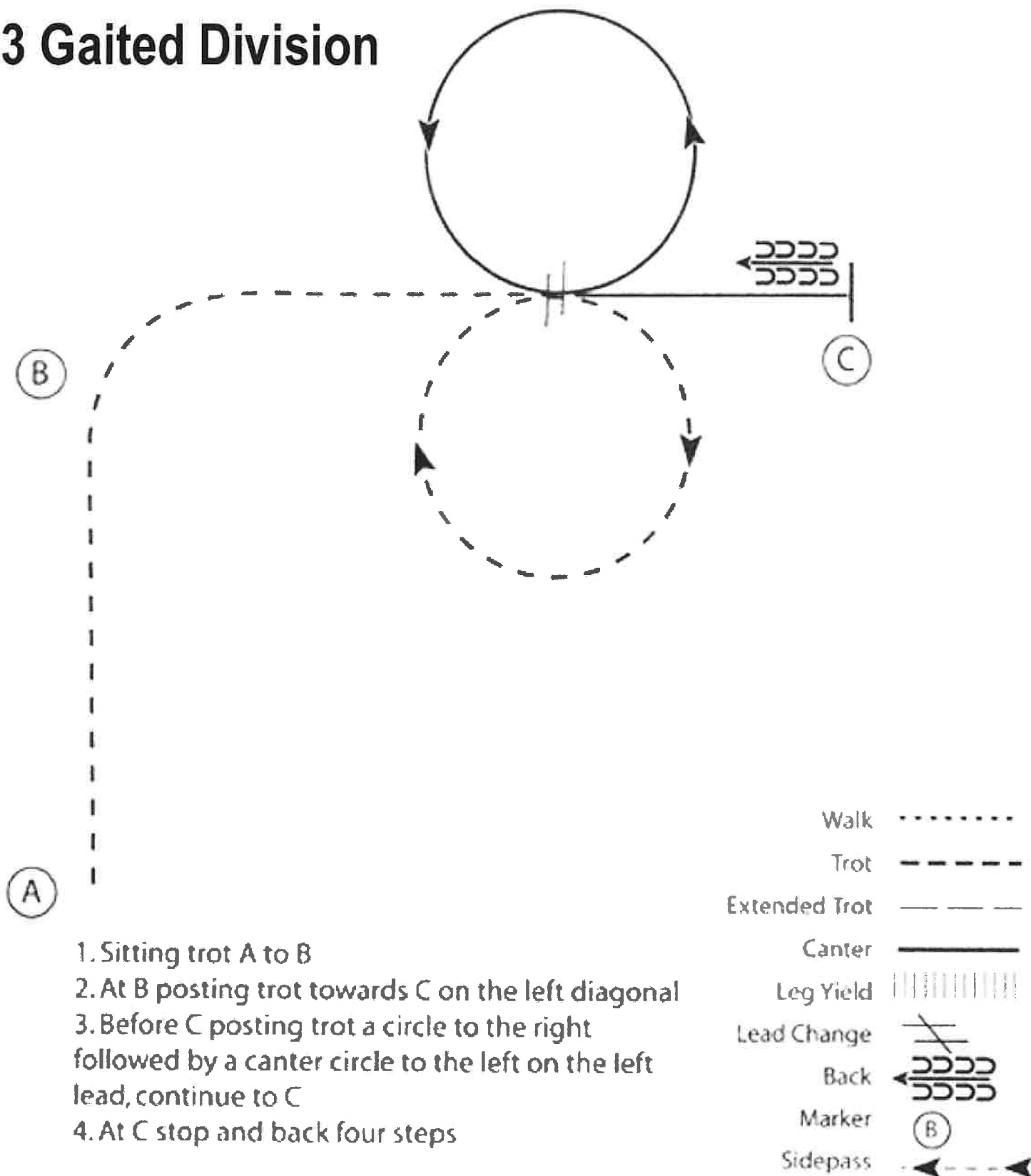

WESTERN HORSEMANSHIP

WALK-JOG ALL AGES - CLASS #37

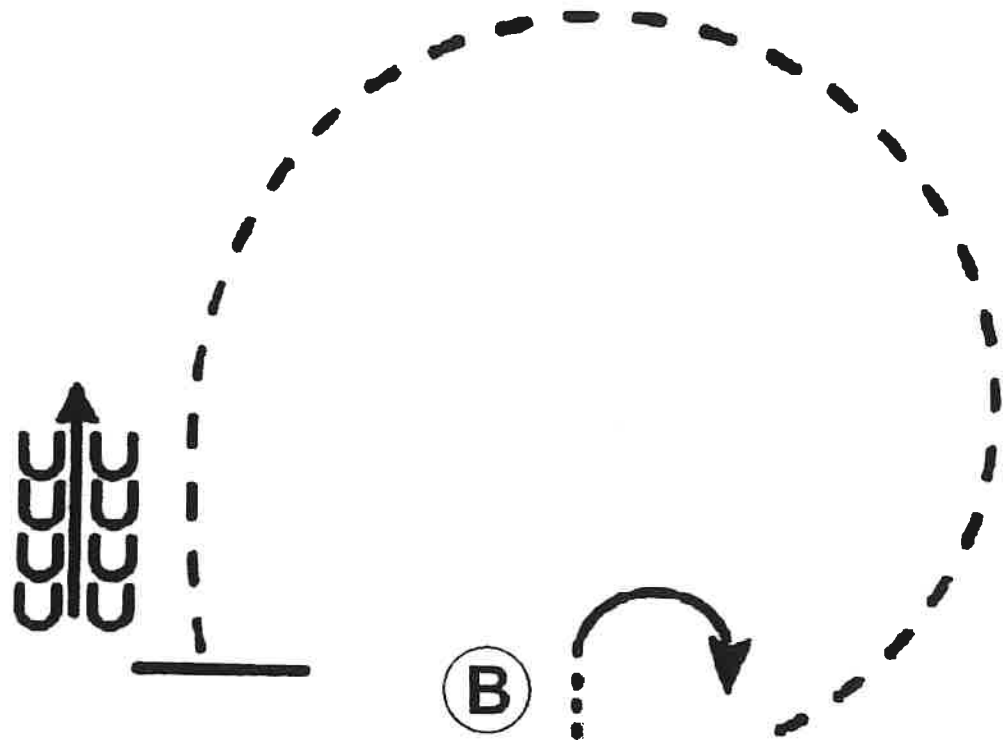

(B)

1. Walk A to B
2. At B perform a 90 degree turn to the right
3. Jog a circle around B
4. At B stop and back 4 steps

(A)

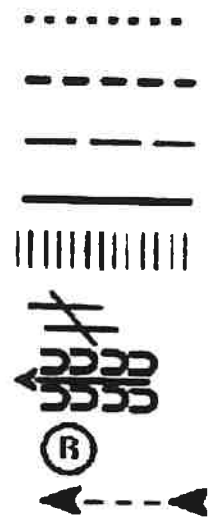

WESTERN HORSEMANSHIP

OPEN with PATTERN - CLASS #38

3 Gaited Division

1. Starting at cone A,
lope circle on left lead
2. Break to walk at cone B
3. Midway between
cones B & C,
lope circle on right lead
4. Stop at cone C
& back 10 steps
5. Jog to rail

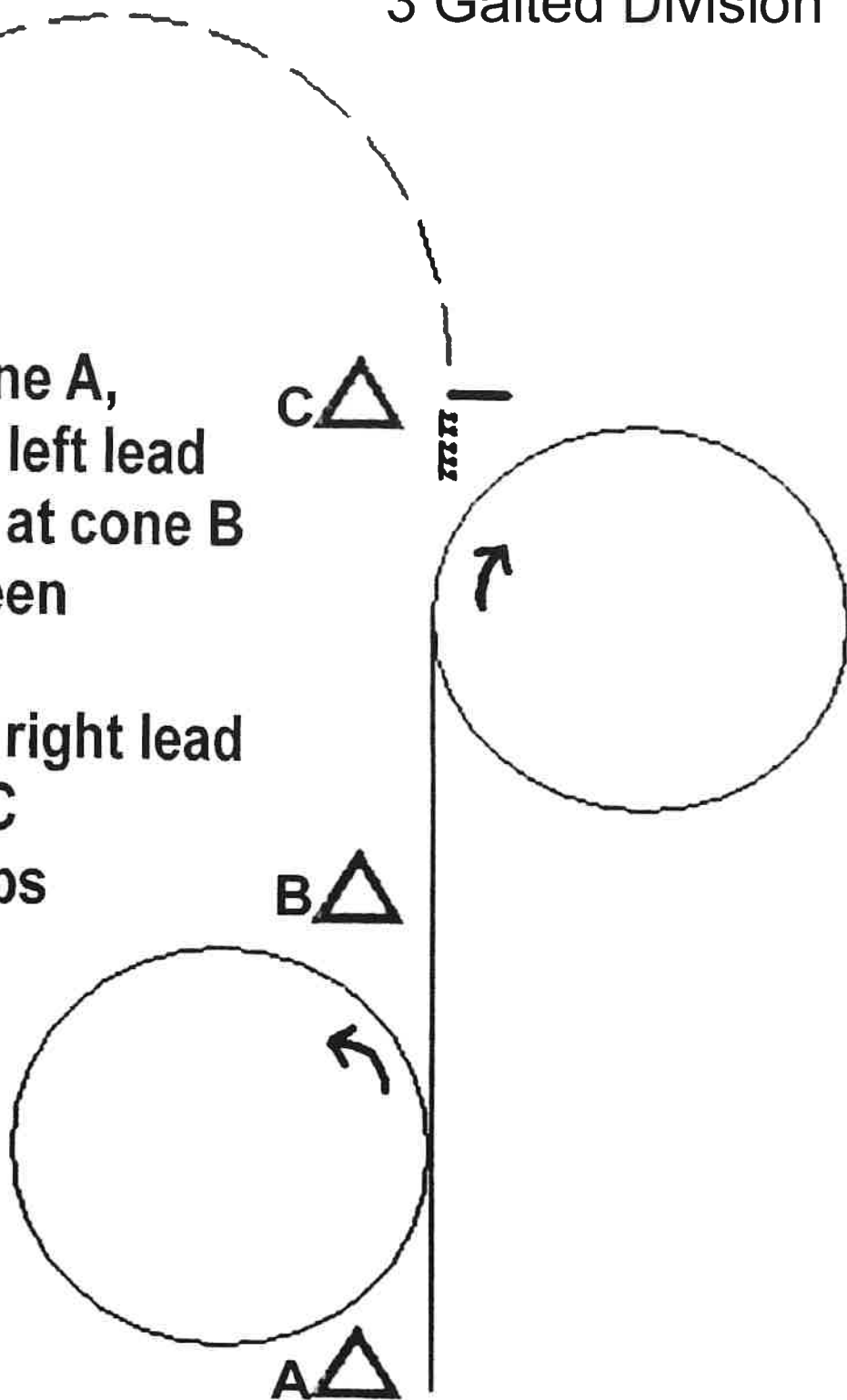

RANCH RIDING - Walk/Trot All Ages

CLASS # 50

1. Walk
2. Extended Trot $\frac{1}{2}$ Way Up The Arena
3. Turn Left Extend Trot to Center
4. Trot Circle to the Left
5. Stop
6. 360 degree Turn to Left
7. Extended Trot
8. Walk over poles
9. Stop & Back One Horse Length

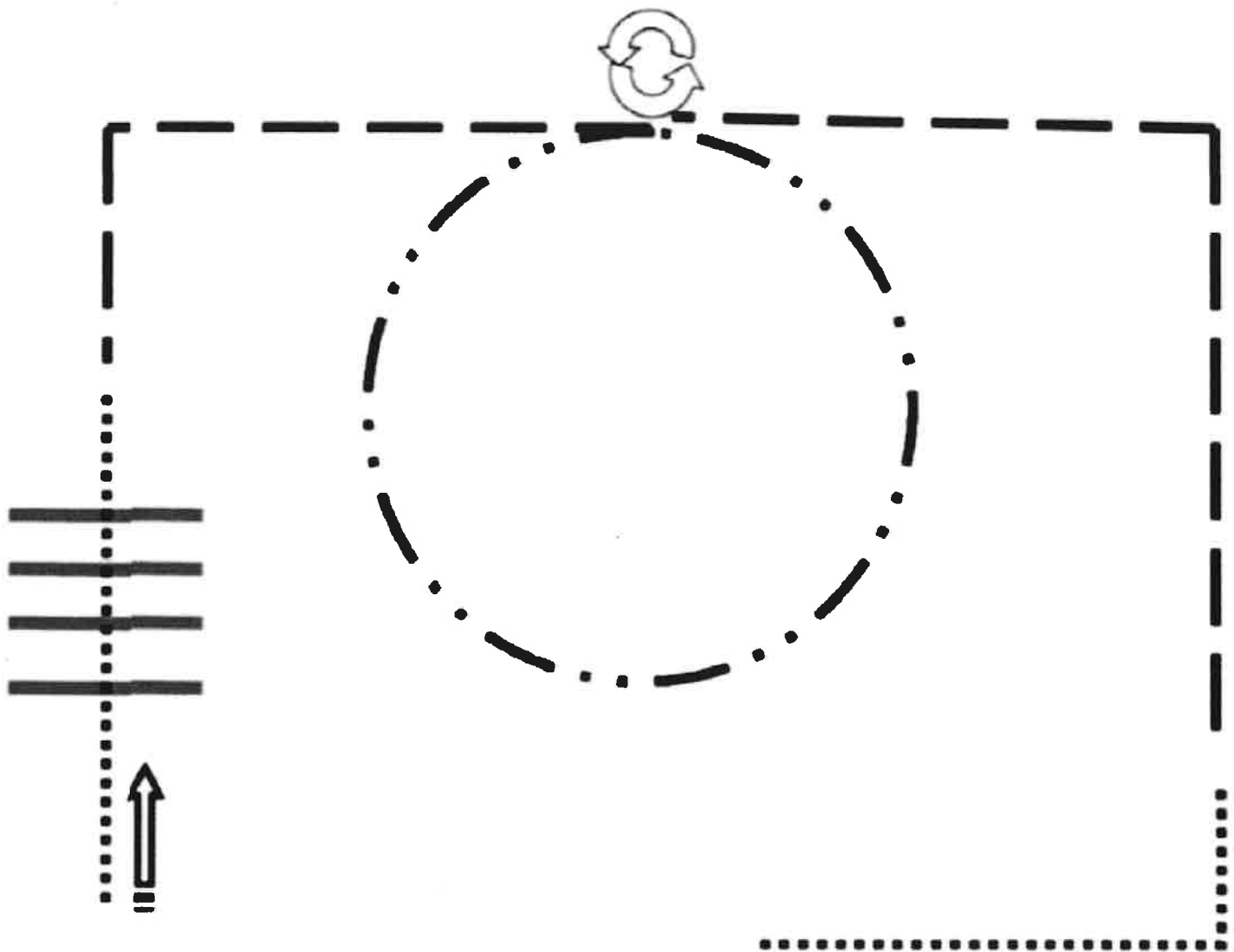

RANCH RIDING - PATTERN 2

CLASS # 51

3 Gaited

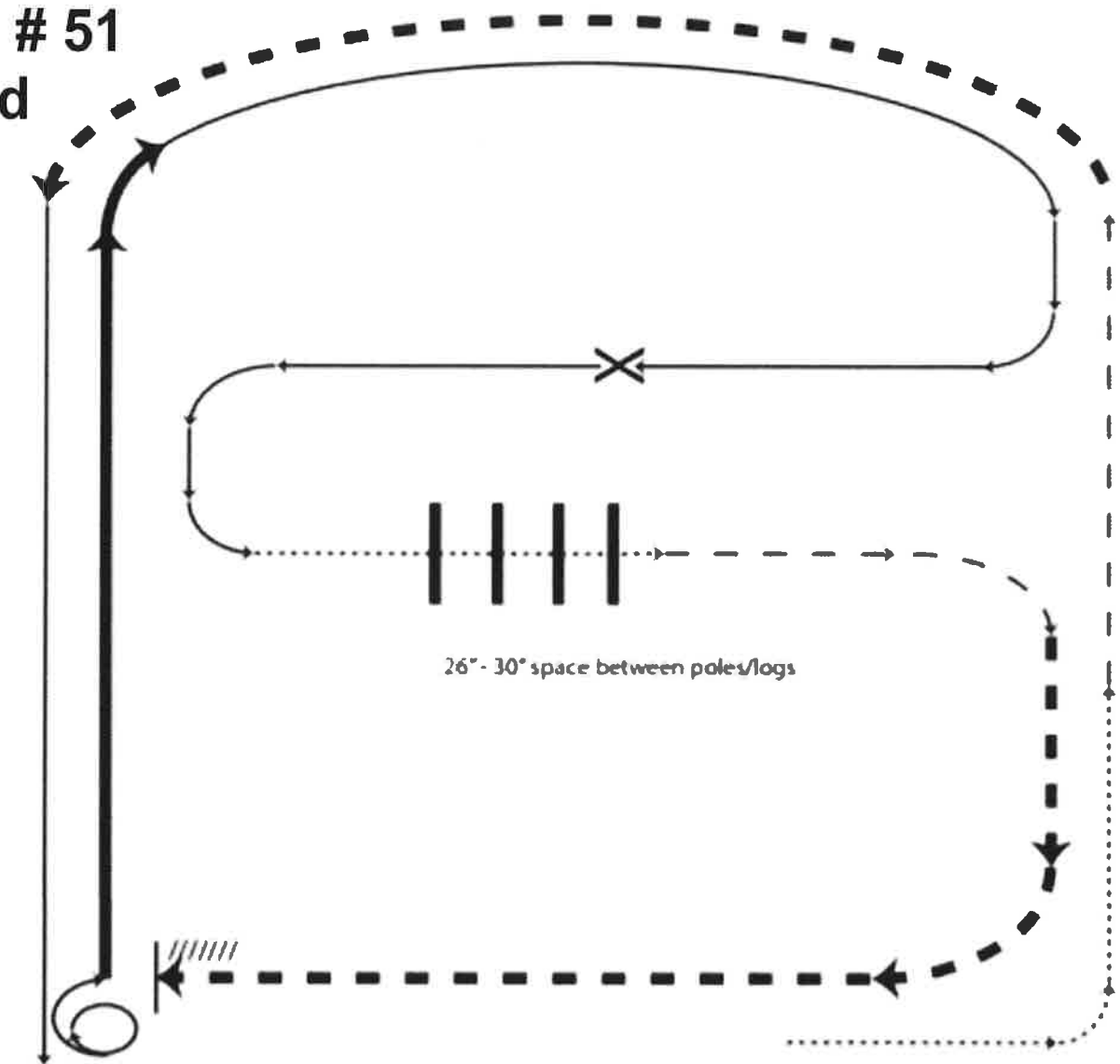

26" - 30" space between poles/logs

1. Walk
2. Trot
3. Extend trot
4. Left lead lope
5. Stop, 1 1/2 turn right
6. Extended lope
7. Collect to working lope-right lead
8. Change leads (simple or flying)
9. Walk
10. Walk over logs
11. Trot
12. Extended Trot
13. Stop and back

- X Lead Change
- • Walk
- - Trot
- — Ext Trot
- — Lope
- — Ext Lope
- //// //// Back

RANCH REINING - PATTERN 4

CLASS # 52

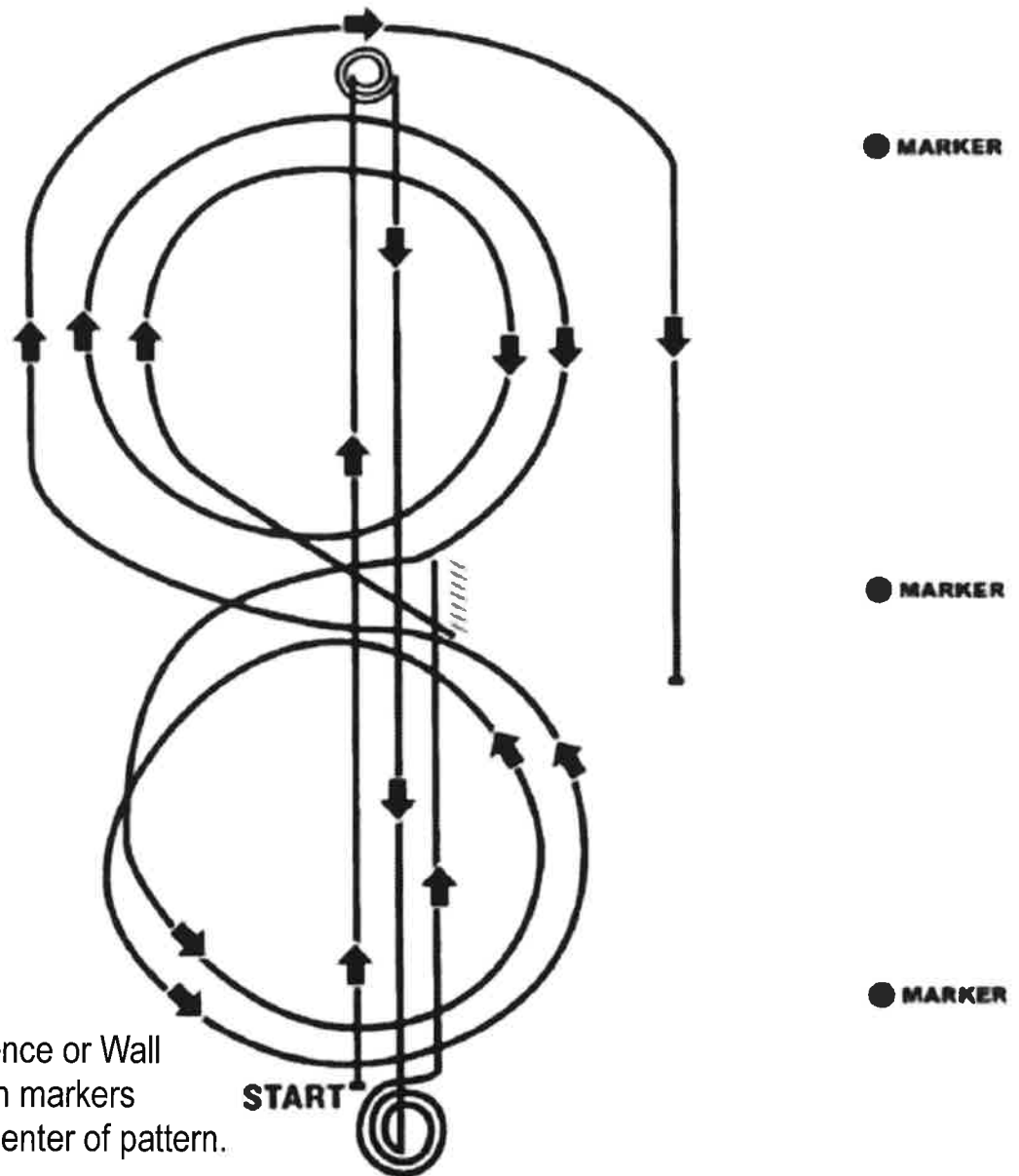

Mandatory Marker along Fence or Wall
The judge shall indicate with markers
on arena fence or wall the center of pattern.
Ride pattern as follows:

1. Run up center of arena past the end marker and come to a sliding stop
2. Complete 3 1/2 spins to the left
3. Run down to other end of arena, past the end marker and come to a sliding stop
4. Complete 3 1/2 spins to the right
5. Run past the center marker and stop
6. Back at least 10 feet in a straight line
7. Complete 1/4 turn to the left, hesitate. Begin on right lead. Complete two circles to the right, the first one small and slow, the second large and fast. Change to left lead.
8. Complete one small and slow circle then one large and fast circle. Change to right lead.
9. Run around end of arena to the other side, past the center marker, at least 20 feet from the fence and come to a sliding stop
10. Hesitate to complete pattern

TRAIL CLASSES

#53 Walk-Jog 10 & Under, #54 Walk-Jog 11 & Over & #62 In-Hand incl Mini/Pony

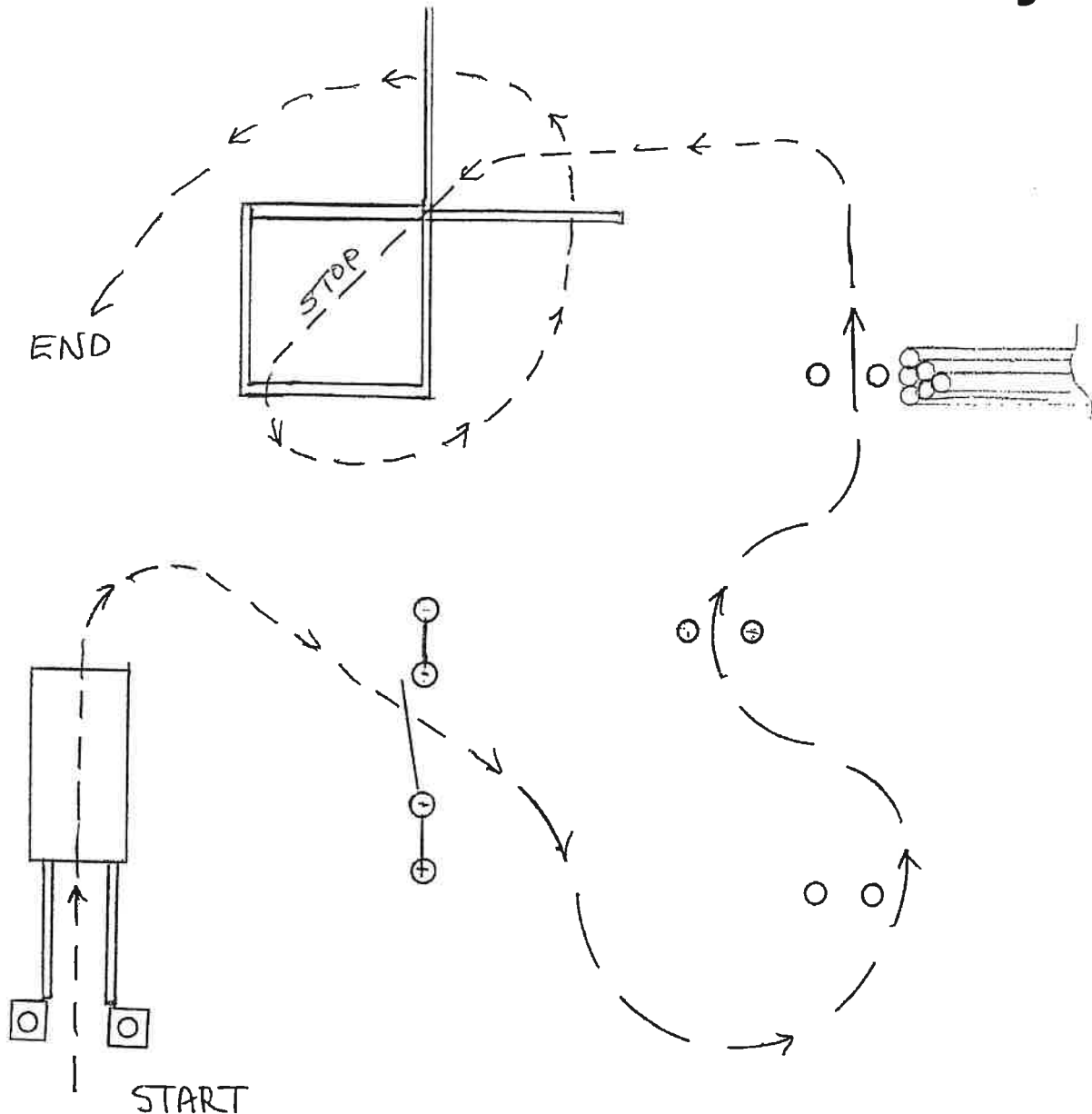

- 1) Walk Thru Chute & Over Bridge
- 2) Walk Thru Open Gate
- 3) Jog Around & Between Pylons as shown
- 4) Walk Across Corner Into Box & Stop
- 5) Walk Out of Box & Over 2 Poles

TRAIL CLASS

#55 Walk-Jog All Ages

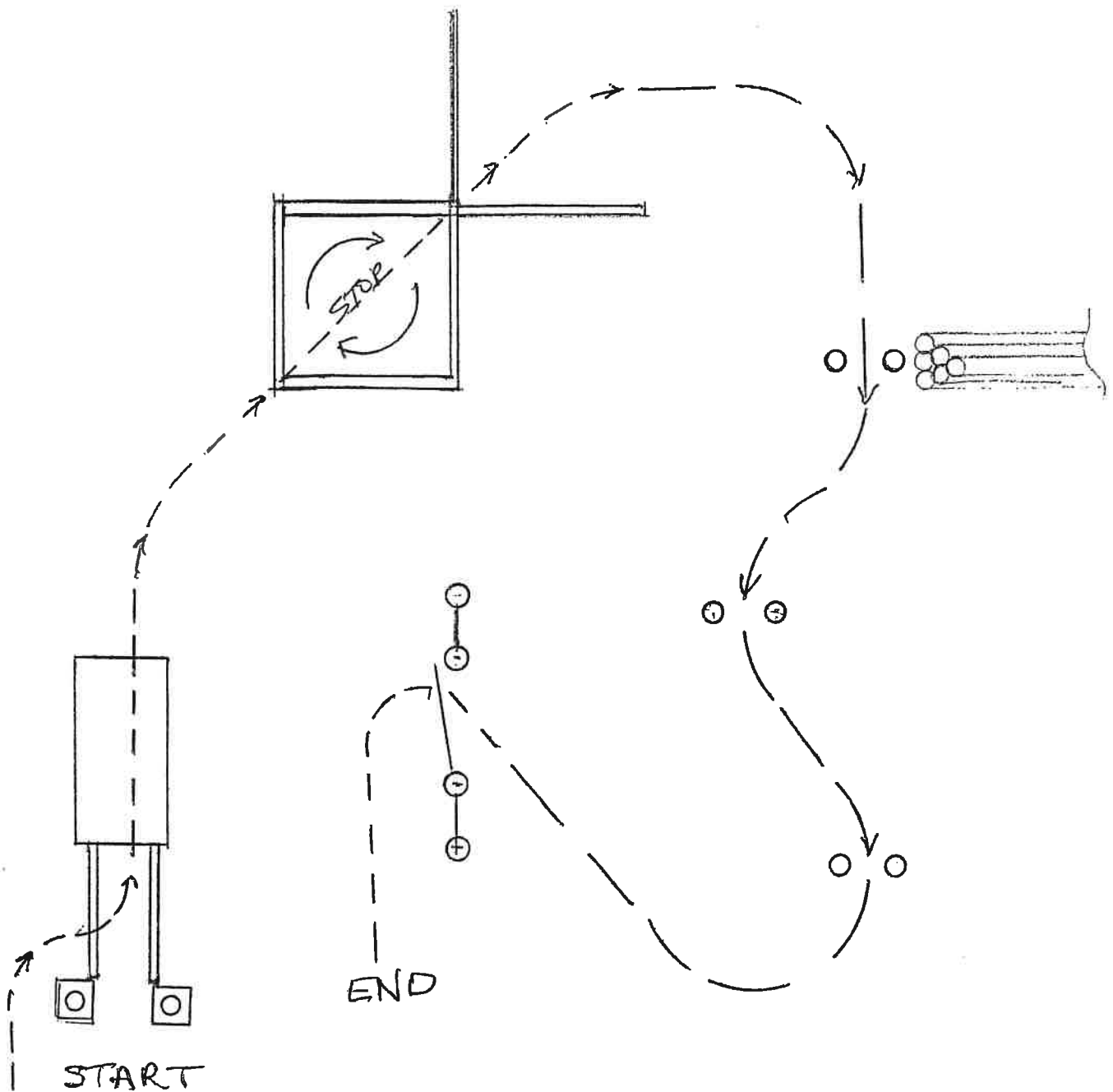

- 1) Walk Over Pole & Across Bridge
- 2) Walk Over Corner & Into Box & Stop
- 3) Full Turn To The Right
- 4) Walk Out of Box & Jog Thru Pylons
- 5) Walk Thru Open Gate & Ride Thru

TRAIL CLASS

#56 Ranch Horse Walk-Trot All Ages

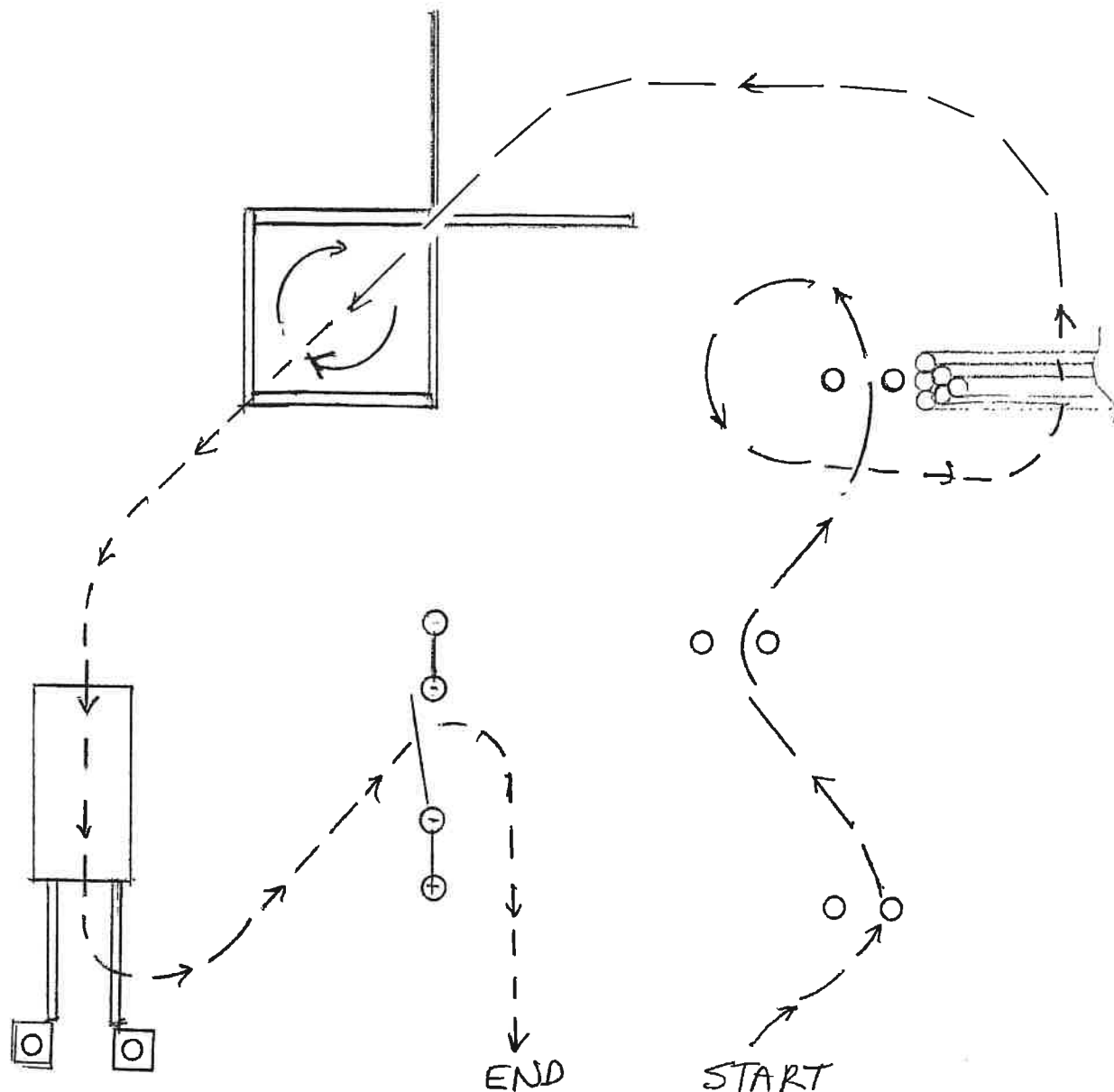

- 1) Jog Thru 1st & 2nd Pylons
- 2) Jog Thru 3rd Pylons & Break to a Walk
- 3) Walk Over Simulated Fallen Tree
- 4) Jog Into Square & Stop
- 5) Full Turn to Right & Walk Out
- 6) Walk Over Bridge & Pole as shown
- 7) Right Hand Gate & Walk Out

TRAIL CLASS

#57 Ranch Horse - 3 Gaited All Ages

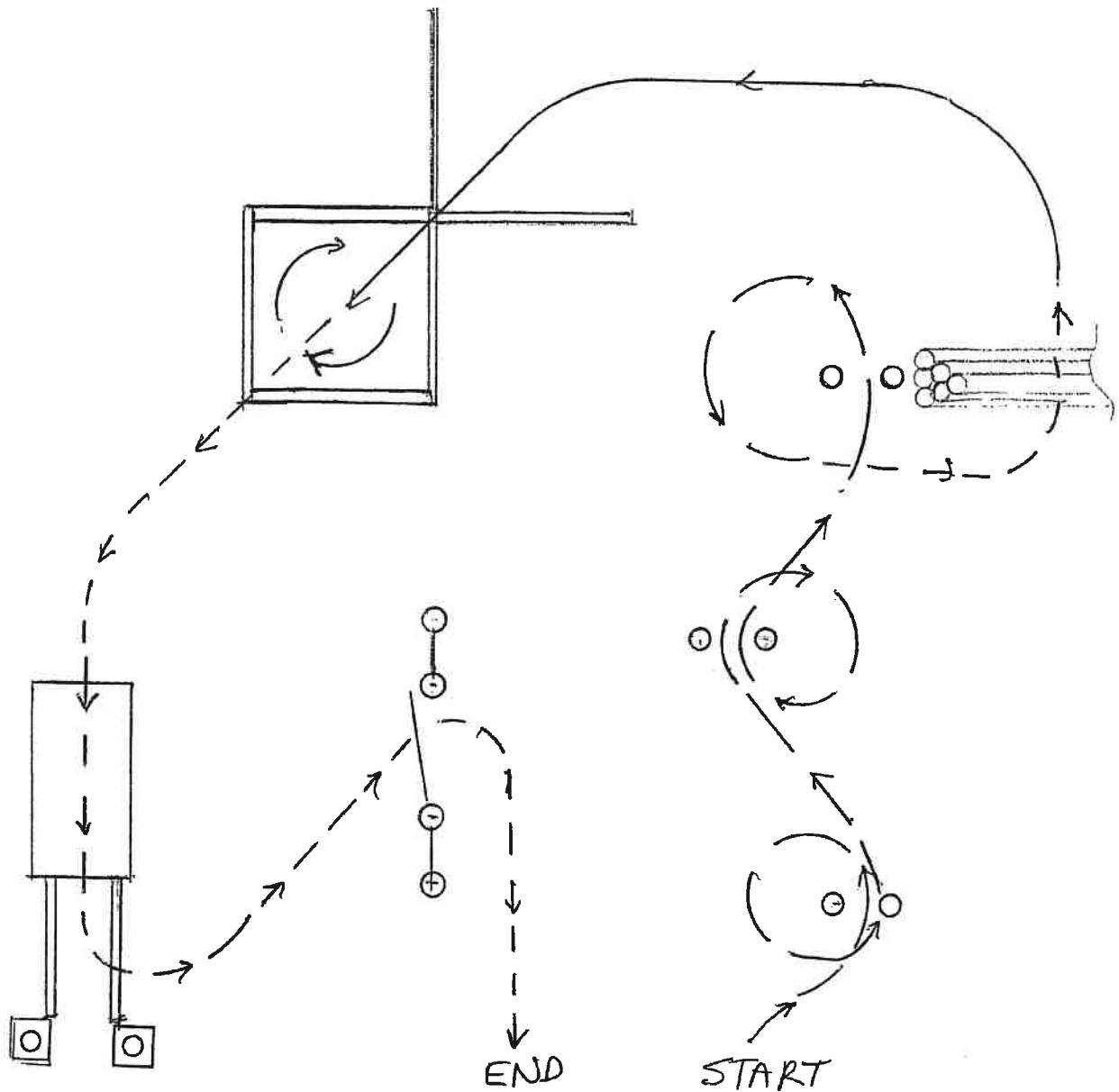

- 1) Jog Thru & Circle 1st & 2nd Pylons
- 2) Jog Thru 3rd Pylons & Break to a Walk
- 3) Walk Over Simulated Fallen Tree
- 4) Lope Left Lead Into Square & Stop
- 5) Full Turn to Right & Walk Out
- 6) Walk Over Bridge & Pole as shown
- 7) Right Hand Gate & Walk Out

TRAIL CLASSES

#58 - 18 & Under, #59 - 19 & Over,
#61 - Open

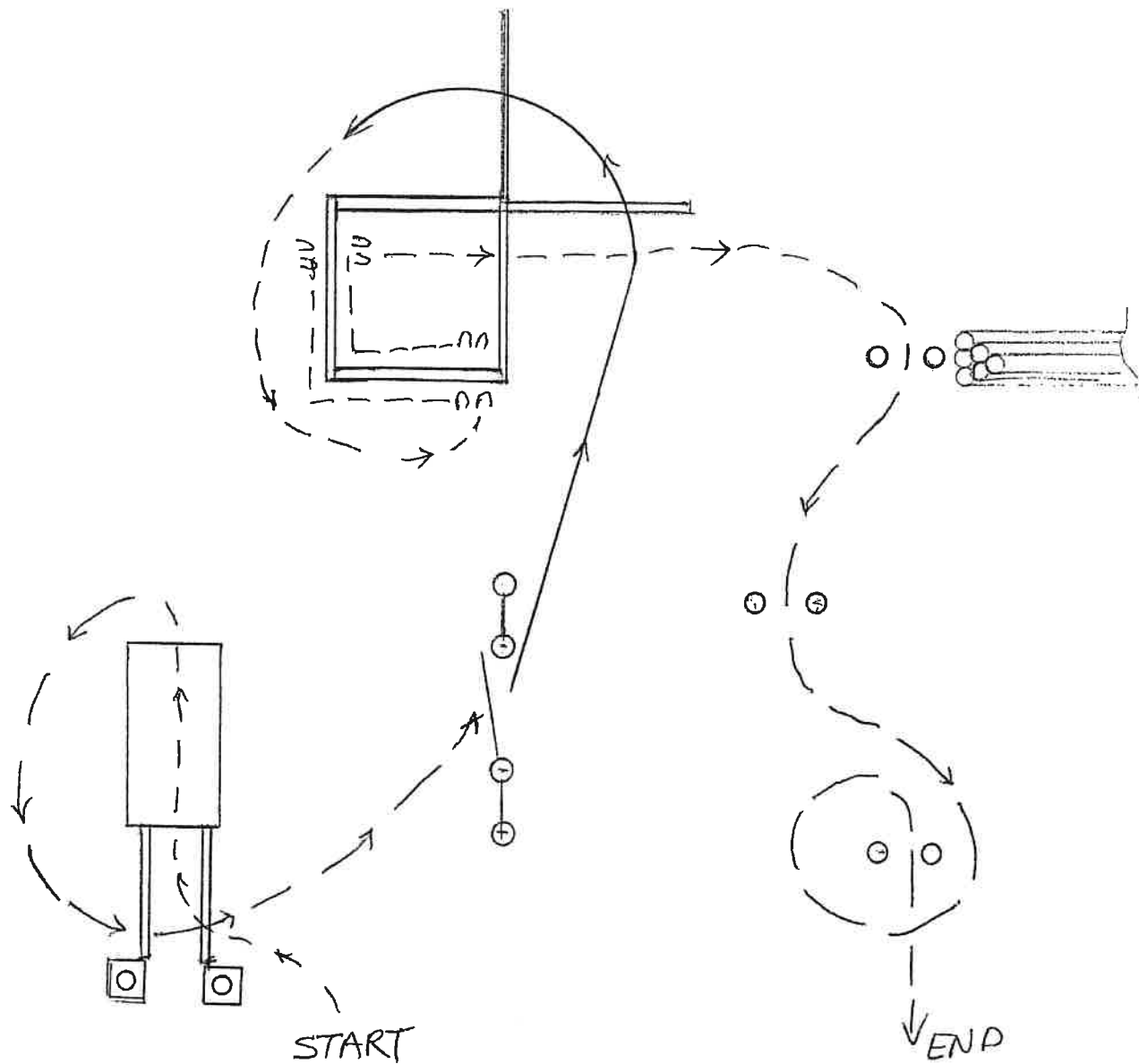

- 1) Walk Over Pole & Across Bridge
- 2) Jog Over 2 Poles to Gate, Right Hand Gate & Close
- 3) Pivot 180 to the Left & Lope Off Left Lead to Poles
- 4) Walk & Step front Feet Into Square
- 5) Sidepass Left as shown, Walk Between 2 Pylons
- 6) Jog Thru 2nd Pylons, Circle 3rd Pylons & Then Between

TRAIL CLASS #60

Novice Horse & Rider - All Ages

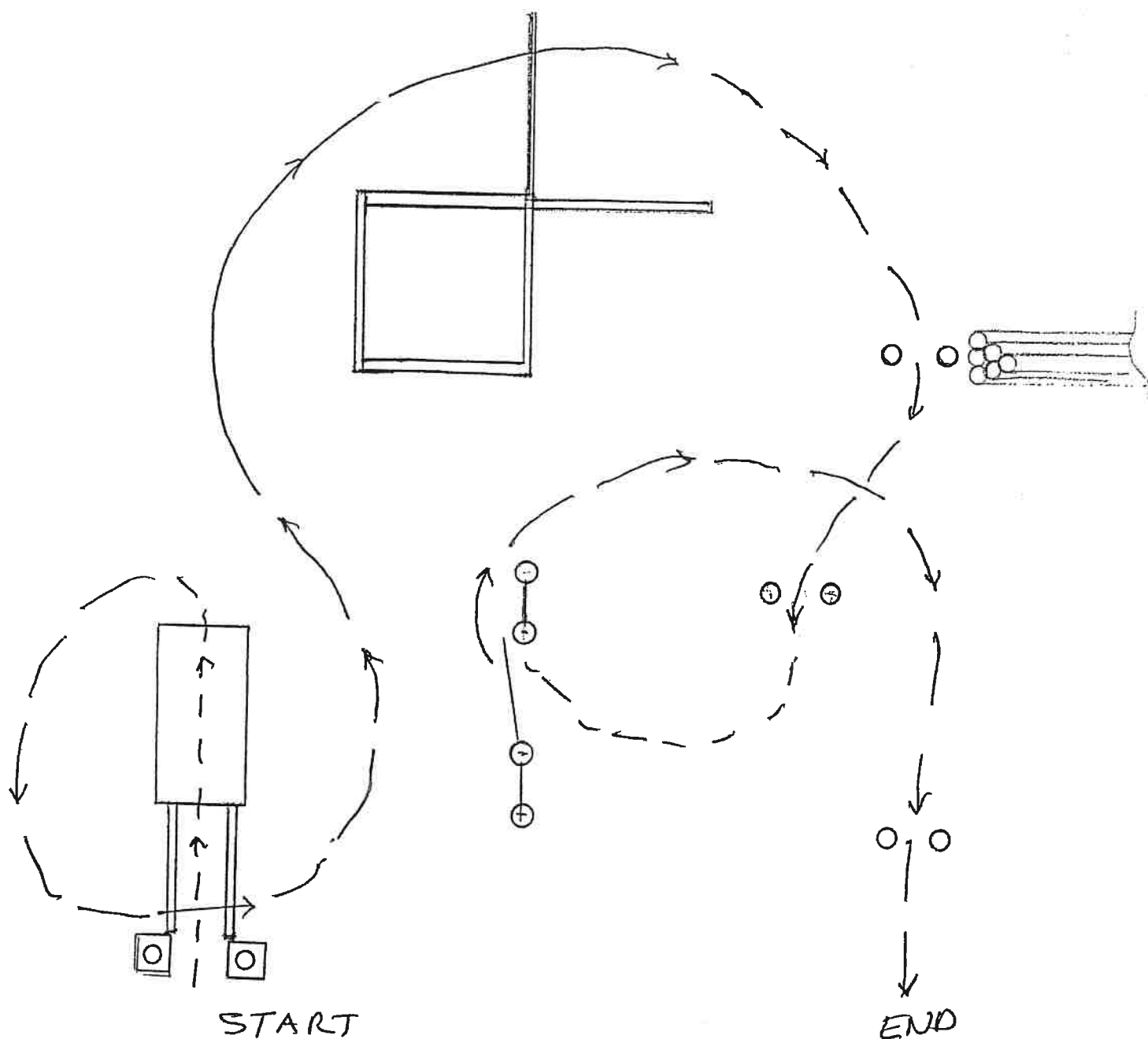

- 1) Walk Thru Chute & Over Bridge
- 2) Jog Over 2 Poles
- 3) Lope Around Box & Over 1 Pole, Break to Jog
- 4) Jog Thru 2 Sets of Cones & Walk To Gate
- 5) Left Hand Gate, Jog Around to Last Set of Cones & Thru