

VRH AND RHC RANCH REINING PATTERN I

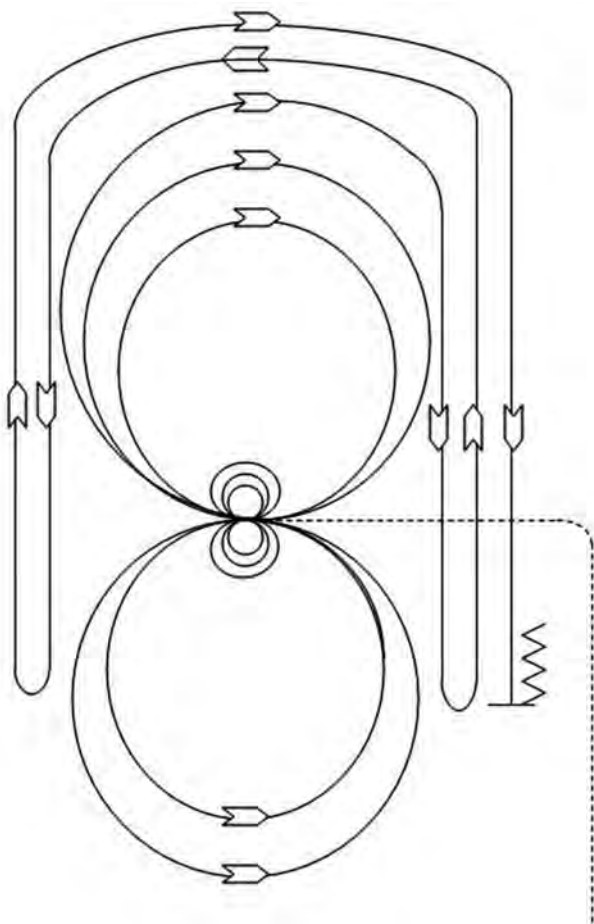

Mandatory Markers along Fence or Wall The judge shall indicate with markers on arena fence or wall the center of the pattern.

Ride pattern as follows: Trot to center of arena and stop.

1. Complete 3 spins in one direction. Hesitate.
2. Complete 3 spins in the opposite direction. Hesitate.
3. Beginning on right lead, complete two large fast circles to the right. Change leads at center of arena.
4. Complete two large fast circles to the left. Change leads at center of arena.
5. Begin a large circle to the right but do not close this circle. Run down the right side of the arena past the center marker and do a left roll back at least 20 feet from the wall or fence, no hesitation.
6. Continue back around the previous circle but do not close this circle. Run down the left side of the arena past the center marker and do a right roll back at least 20 feet from the wall or fence, no hesitation.
7. Continue back around previous circle, but do not close this circle. Run down the right side of the arena past the center marker and do a sliding stop at least 20 feet from the wall or fence. Back up at least 10 feet. Hesitate to show completion of pattern.

VRH AND RHC RANCH REINING PATTERN 2

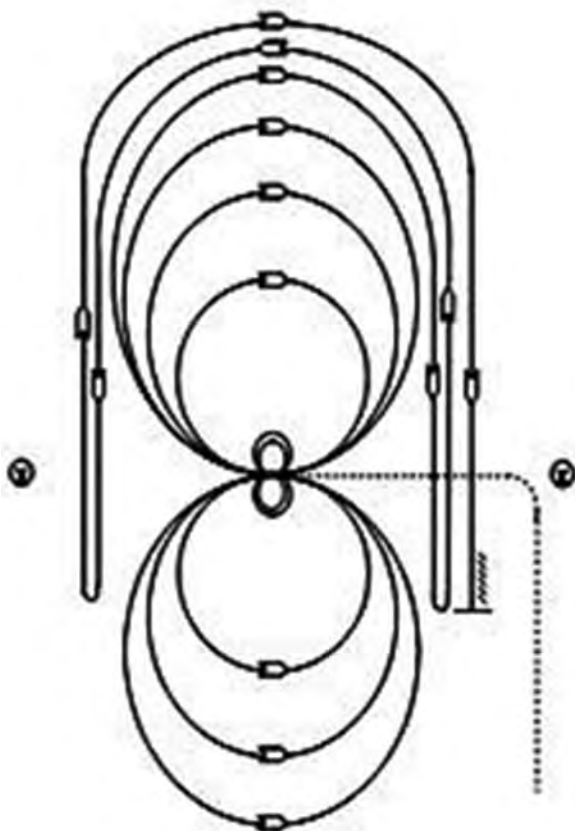

Mandatory Markers along Fence or Wall The judge shall indicate with markers on arena fence or wall the center of pattern.

Ride pattern as follows: Trot to center of arena and stop or walk before departure.

1. Beginning on right lead, complete two circles to the right - the first one large and fast; the second one small and slow. Stop at center.
2. Complete 4 spins to the right. Hesitate.
3. Beginning on left lead, complete two circles to the left - the first one large and fast; the second one small and slow. Stop at center.
4. Complete 4 spins to the left. Hesitate.
5. Beginning on the right lead, complete a large fast circle to the right and change leads at center of arena. Complete a large fast circle to the left and change leads at center of arena.
6. Begin a large fast circle to the right, but do not close this circle. Run down the right side of the arena, past the center marker, and do a left roll back at least 20 feet from the wall or fence.
7. Continue back around the previous circle, but do not close this circle. Run down the left side of the arena, past the center marker, and do a right roll back at least 20 feet from the wall or fence.
8. Continue back around previous circle, but do not close this circle. Run down right side of the arena, past the center marker, and do a sliding stop at least 20 feet from the wall or fence. Back up at least 10 feet. Hesitate to show completion of pattern.

VRH AND RHC RANCH REINING PATTERN 4

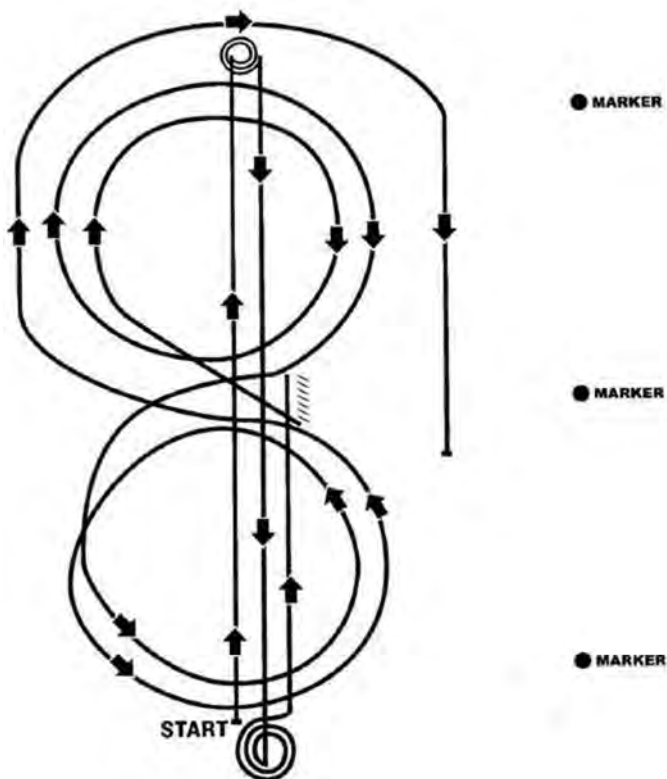

Mandatory Marker along Fence or Wall The judge shall indicate with markers on arena fence or wall the center of pattern. Judge shall also end place markers on fence or wall at least 50' from each end of the arena.

Ride pattern as follows:

1. Run up center of arena past the end marker and do a sliding stop.
2. Complete 3 1/2 spins to the left.
3. Run down to opposite end of arena, past the end marker and do a sliding stop.
4. Complete 3 1/2 spins to the right.
5. Run past the center marker and do a sliding stop. Back at least 10 feet. Complete 1/4 turn to the left; hesitate.
6. Beginning on right lead, complete two circles to the right - the first one small and slow, the second one large and fast. Change leads at center of arena.
7. Complete two circles to the left - the first one small and slow, the second one large and fast. Change leads at center of arena.
8. Begin a large circle to the right but do not close this circle. Run down the right side of the arena, past the center marker and do a sliding stop at least 20 feet from the fence. Hesitate to show completion of pattern.

VRH AND RHC RANCH REINING PATTERN 5

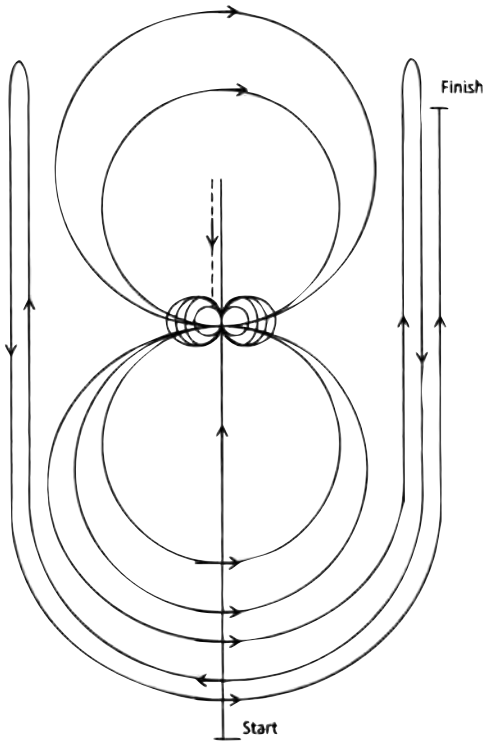

Mandatory Markers along Fence or Wall The judge shall indicate with markers on arena fence or wall the center of pattern. Judge shall also place markers on fence or wall at least 50' from each end of the arena.

Ride pattern as follows:

1. Run past the center marker and do a sliding stop. Back to center of arena or at least 10 feet. Hesitate.
2. Complete four right spins. Hesitate.
3. Complete four and one-quarter left spins. Hesitate. Horse to be facing left fence.
4. Beginning on left lead, complete two circles to the left - the first one small and slow, the second one large and fast. Change leads at center of arena.
5. Complete two circles to the right - the first one small and slow, the second one large and fast. Change leads at center of arena.
6. Begin a large circle to the left, but do not close this circle. Run up the right side of the arena, past the center marker, and do a right rollback at least 20 feet from the wall or fence.
7. Continue back around the previous circle, but do not close circle. Run up the left side of the arena, past the center marker, and do a left rollback at least 20 feet from the wall or fence.
8. Continue back around previous circle, but do not close this circle. Run up the right side of the arena, past the center marker, and do a sliding stop at least 20 feet from the wall or fence. Hesitate to show completion of pattern.

VRH AND RHC RANCH REINING PATTERN 6

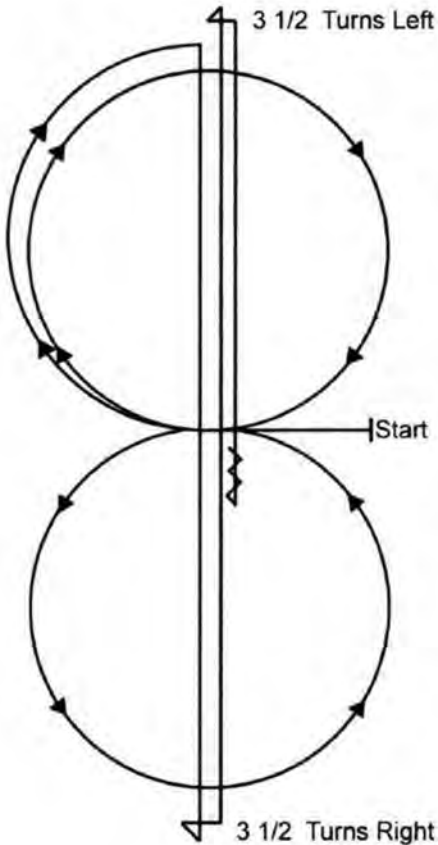

Mandatory Marker along Fence or Wall The judge shall indicate with markers on arena wall or fence the center of pattern. Judge shall also place markers on fence or wall at least 50' from each end of the arena.

Ride pattern as follows: Trot to center of arena and stop or walk before departure. Start pattern facing toward judge.

1. Beginning on right lead, lope one circle to the right. Change leads at center of arena.
2. Complete one circle to the left. Change leads at center of arena.
3. Begin a circle to the right, but do not close this circle. Run down center of arena, past the end marker, and do a sliding stop.
4. Complete 3 1/2 spins to the right.
5. Run up to other end of arena, past the end marker, do a sliding stop.
6. Complete 3 1/2 spins to the left.
7. Run past the center marker and do a sliding stop. Back at least 10 feet. Hesitate to show completion pattern.

VRH AND RHC RANCH REINING PATTERN 7

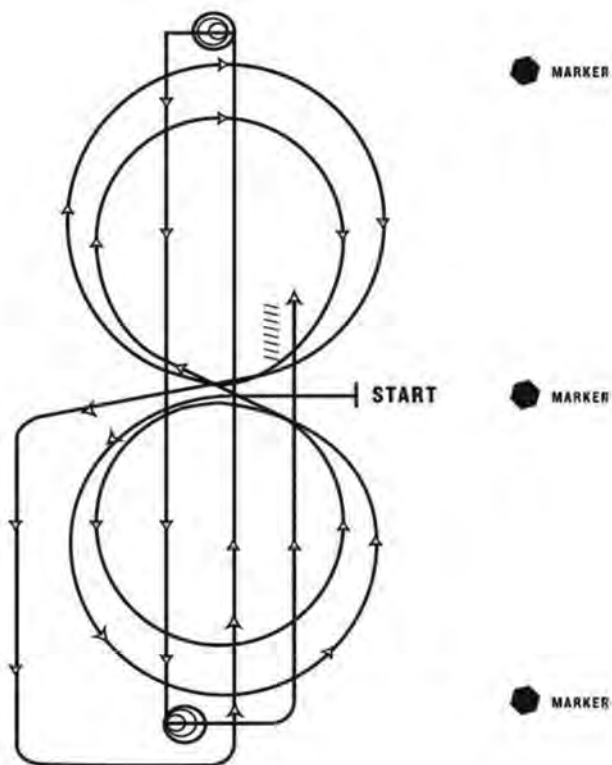

Mandatory Marker along Fence or Wall The judge shall indicate with markers on arena wall or fence the center of pattern. Judge shall also place markers on fence or wall at least 50' from each end of the arena.

Ride pattern as follows: Trot to center of arena and stop or walk before departure. Start pattern facing toward judge.

1. Beginning on left lead, complete two circles to the left - the first one large and fast, the second one small and slow. Change leads at center of arena.
2. Complete two circles to the right - the first one large and fast, the second one small and slow. Change leads at center of arena.
3. Begin a circle to the left, but do not close this circle. Continuing around the end of arena, run up the center, past end marker, and do a sliding stop.
4. Complete 3 1/2 spins to the left.
5. Run down to other end of arena, past the end marker, and do a sliding stop.
6. Complete 3 1/2 spins to the right.
7. Run past the center marker and do a sliding stop. Back at least 10 feet. Hesitate to show completion pattern