



# **1050RT | 1050RT (EU) | 1050RT X-Series**

CompactTrack Loader  
Operator's Manual

50950436 Rev. H 05/21

Original Instructions



## **WARNING**

**This product can expose you to lead which is known to the State of California to cause cancer and birth defects or other reproductive harm. For more information go to [www.P65Warnings.ca.gov](http://www.P65Warnings.ca.gov)**

## **WARNING**

**Breathing diesel engine exhaust exposes you to chemicals known to the state of California to cause cancer and birth defects or other reproductive harm.**

- **Always start and operate the engine in a well-ventilated area.**
- **If in an enclosed area, vent the exhaust to the outside.**
- **Do not modify or tamper with the exhaust system.**
- **Do not idle the engine except as necessary.**

**For more information go to [www.P65warnings.ca.gov/diesel](http://www.P65warnings.ca.gov/diesel).**

## MANITOU EQUIPMENT AMERICA, LLC WARRANTY

Manitou Equipment America, LLC under the GEHL®, MUSTANG by MANITOU®, MANITOU®, brand warrants new MANITOU Group equipment to the Original Retail Purchaser to be free from defects in material and workmanship for a period of twelve (12) months or Two Thousand Hours (2000 h) from the Warranty Start Date which occur first.

### MANITOU Group WARRANTY SERVICE INCLUDES:

Genuine XPRT parts and labor costs required to repair or replace equipment at the selling dealer's business location.

**MANITOU Group MAKES NO REPRESENTATIONS OR WARRANTIES OF ANY KIND, EXPRESS OR IMPLIED (INCLUDING THE IMPLIED WARRANTIES OF MERCHANTABILITY AND FITNESS FOR PARTICULAR PURPOSE), EXCEPT AS EXPRESSLY STATED IN THIS WARRANTY STATEMENT.**

ANY OF THESE LIMITATIONS EXCLUDED BY LOCAL LAW SHALL BE DEEMED DELETED FROM THIS WARRANTY; ALL OTHER TERMS WILL CONTINUE TO APPLY.

SOME STATES DO NOT PERMIT THE EXCLUSION OR LIMITATION OF THESE WARRANTIES AND YOU MAY HAVE GREATER RIGHTS UNDER YOUR STATE LAW.

### MANITOU Group WARRANTY DOES NOT INCLUDE:

1. Transportation to selling dealer's business location or, at the option of the Original Retail Purchaser, the cost of a service call.
2. Used equipment.
3. Components covered by their own non- MANITOU Group warranties, such as tires, batteries, trade accessories and engines.
4. Normal maintenance service and expendable, high-wear items.
5. Repairs or adjustments caused by: improper use; failure to follow recommended maintenance procedures; use of unauthorized attachments; accident or other casualty.
6. Liability for incidental or consequential damages of any type, including, but not limited to lost profits or expenses of acquiring replacement equipment.
7. Liability for consequential damages as an unfavorable environment (chemicals, dust, salt, corrosion and erosion...)
8. Repairs completed outside MANITOU Group network and/or by personnel not trained by MANITOU Group.

No agent, employee or representative of MANITOU group has any authority to bind of MANITOU group to any warranty except as specifically set forth herein.

This agreement has been prepared in multiple languages, including but not limited to, English, Spanish, and French (Canada). In the event of any inconsistency, the English version shall apply and be binding upon the parties.

# TABLE OF CONTENTS

<b>INTRODUCTION</b>	<b>5</b>
Safety Symbol and Signal Words .....	5
Contents and Use of this Manual .....	5
Machine Orientation .....	6
Proper Machine Use .....	6
Service and Registration .....	6
Component Identification .....	8
List of Attachments .....	9
Using Attachments .....	10
Vibration Information .....	10
Fire Extinguisher .....	11
Manufacturer Information .....	11
Indicator and Operation Symbols .....	12
<b>SAFETY</b>	<b>15</b>
Safety Symbol and Signal Words .....	15
Mandatory Safety Shutdown Procedure .....	16
Before Starting .....	17
During Operation .....	18
Applications with Load-Handling Devices .....	20
Parking the Machine .....	21
Electrical Energy .....	21
Maintenance and Service Safety Practices .....	22
Battery Hazards .....	24
Fire Hazards .....	24
Additional Safety Equipment .....	25
Crystalline Silica Exposure .....	25
<b>DECALS</b>	<b>27</b>
General Information .....	27
Decal Locations .....	27
<b>SPECIFICATIONS</b>	<b>37</b>
Fluids/Lubricants Types and Capacities .....	37
Dimensions .....	38
Payloads/Capacities .....	39
Weights .....	40



Coolant Compound Table . . . . .	40
Tracks . . . . .	40
Engine . . . . .	40
Hydraulic System . . . . .	42
Sound Power/Pressure Levels . . . . .	42
Vibration Levels . . . . .	43
Standard and Optional Features . . . . .	44
Common Materials and Densities . . . . .	45

## **INDICATORS AND CONTROLS 47**

Display(s) . . . . .	48
Switch Panel . . . . .	54
Operator's Seat . . . . .	56
Throttle Controls . . . . .	56
Travel Controls . . . . .	57
Lift Arm Float . . . . .	57
Emergency Lift Arm Lower . . . . .	57
Parking Brake/ Hydraulics Transport Lockout . . . . .	57
Horn . . . . .	58
Cab Heat (Option) . . . . .	58
Windshield Wiper/Washer . . . . .	58
Beacon (Option) . . . . .	59
Battery Disconnect Switch . . . . .	59

## **OPERATION 61**

Operational Checks/Pre-start Inspection . . . . .	61
Before Operation . . . . .	62
Seat Belt . . . . .	62
Starting the Engine . . . . .	63
Engine Warm Up . . . . .	65
Run-In Period . . . . .	66
Stopping the Engine . . . . .	66
Engine Stalling . . . . .	66
Safety Interlock System (Hydraloc™) . . . . .	66
Travel Drive Operation . . . . .	67
Back-up Alarm . . . . .	72
Rubber Track Use Cautions and Tips . . . . .	72

Sprocket Tooth Wear and Track Life . . . . .	74
Lift Arm Operation . . . . .	75
Lift Arm Lift Support . . . . .	76
Self-Leveling (Option) . . . . .	79
Float Control . . . . .	79
Connecting/Disconnecting Attachments . . . . .	79
Powering Attachments with Hydraulic Function . . . . .	80
Working with Buckets . . . . .	83
Working with Pallet Forks . . . . .	88
Diesel Particulate Filter (DPF) Regeneration Procedures . . . . .	90
After Operation . . . . .	94
Jump-Starting . . . . .	94
Lifting the Machine using a Crane . . . . .	95
Towing / Transporting the Machine . . . . .	96
Loading and Transporting the Machine on a Transport Vehicle . . . . .	97
Long-Term Storage . . . . .	99
Final Shutdown / Decommissioning . . . . .	99

## **LUBRICATION 101**

Types of Lubricants . . . . .	101
Lubricant Capacities . . . . .	101
Lubrication Points and Decals . . . . .	102
Lubrication Schedule/Intervals . . . . .	104
Filter Table . . . . .	105

## **MAINTENANCE 107**

Maintenance Schedule . . . . .	107
Maintenance Interval . . . . .	107
Engine Maintenance . . . . .	109
DPF Exhaust System Service . . . . .	112
Fuel System Maintenance . . . . .	112
Hydraulic System Maintenance . . . . .	114
Engine Cooling System . . . . .	116
Alternator/Fan Belt . . . . .	117
Hydraulic Hose Maintenance . . . . .	118
Travel Motor Maintenance . . . . .	118
Tracks . . . . .	119

Electrical System . . . . .	121
Windshield Washer Reservoir . . . . .	123
Maintenance Log . . . . .	124
Maintenance Log . . . . .	125
Maintenance Log . . . . .	126
Maintenance Log . . . . .	127

## **TROUBLESHOOTING 129**

Engine Troubleshooting . . . . .	129
Indicator Lamp Troubleshooting . . . . .	131
Seal and Hose Troubleshooting . . . . .	132
Hydraulic System Troubleshooting . . . . .	132
Hydrostatic Travel Drive System Troubleshooting . . . . .	135
Electrical Troubleshooting . . . . .	137
Error Codes . . . . .	139

Index . . . . .	145
Torque Specifications . . . . .	149

# Chapter 1

## INTRODUCTION

### Safety Symbol and Signal Words

This manual and decals on the machine warn of safety hazards and should be read and observed closely.

Manitou Group, in cooperation with the Society of Automotive Engineers, has adopted this:



This symbol is used throughout this operator's manual and on the decals on the machine. It identifies potential safety hazards, which, if not properly avoided, could result in injury. When you see this symbol in this manual or on the machine, you are reminded to BE ALERT! Personal safety is involved!

### Signal Words



The word "DANGER" indicates an imminently hazardous situation, that, if not avoided, will result in serious injury or death.



The word "WARNING" indicates a potentially hazardous situation that, if not avoided, could result in serious injury or death.



The word "CAUTION" indicates a potentially hazardous situation that, if not avoided, may result in minor or moderate injury.

**IMPORTANT:** *The word "IMPORTANT" indicates situations that can result in possible damage to the machine.*

**NOTE:** *The word "NOTE" indicates special or particularly useful information.*

### Contents and Use of this Manual

This operator's manual provides information about the safe and proper operation and maintenance for the machine. Major points of safe operation and maintenance are detailed in the Safety chapter of this manual.

This manual also includes general troubleshooting and specification information about the machine.

Follow the instructions in the Safety, Operation and Maintenance chapters concerning accident prevention regulations, safety and occupational regulations, and machine and traffic regulations. Manitou Americas is not liable for damage resulting from the failure to follow these regulations.



Improper operation, inspection and maintenance of the machine can cause injury or death. Read and understand the contents of this manual COMPLETELY and become familiar with the machine before operating it.

It is the owner's or employer's responsibility to fully instruct each operator in the proper and safe operation and maintenance of the machine.

# Introduction

---

A storage location is provided behind the operator's seat for storing the operator's manual. After using the manual, return it to the storage container.

This manual is considered a permanent part of the machine and should be with the machine at all times. If the machine is resold, include this operator's manual as part of the sale.

Replace this manual promptly if it becomes damaged, lost or stolen.

Some illustrations in this manual may show doors, guards and shields open or removed for illustrative purposes only. BE SURE all doors, guards and shields are in their proper operating positions BEFORE starting the engine to operate the machine.

Because of ongoing product improvements, information included in this manual may not exactly match the machine. Manitou Group reserves the right to modify and improve products at any time without notice or obligation.

## Machine Orientation

"Right" and "left", as described in this manual, are determined from a position sitting in the operator's seat and facing forward.

## Proper Machine Use



**Improper use of the machine can result in property damage, injury or death.**

---

The machine is designed only for digging, picking up, lifting, transporting and unloading materials. Use of approved attachments is also allowed. Using the machine in any other way is considered contrary to the intended use. Compliance with, and strict adherence to, the conditions of operation, service, and repair as specified by the manufacturer also constitute essential elements of the intended use.

The machine was designed and built according to the best available technology and approved safety regulations in the countries where it is sold. However, it is impossible to completely safeguard against abusive, improper use. The operator must always consider potential safety risks and hazards during operation. Accident prevention regulations, all road traffic regulations, and all other generally recognized safety and occupational medicine regulations must be observed at all times.

The machine must be maintained in proper operating condition. Any damaged or malfunctioning parts must be repaired or replaced immediately.

Any arbitrary modification carried out to the machine may relieve the manufacturer of liability for any resulting damage or injury.

## Service and Registration

The wide Manitou Group dealership network stands ready to provide any assistance that may be required, including genuine service parts. All parts should be obtained from or ordered through your dealer.

When ordering service parts, provide complete information about the part and the quantity required. Also provide the model and serial numbers of the machine. For your safety and continued proper operation, use only genuine service parts. Record the model and serial numbers in the spaces below for quick reference.

## Machine Model and Serial Numbers

Machine Model Number

---

Machine Serial Number

---



## Component Serial Numbers

Engine Model Number

---

Engine Serial Number

---

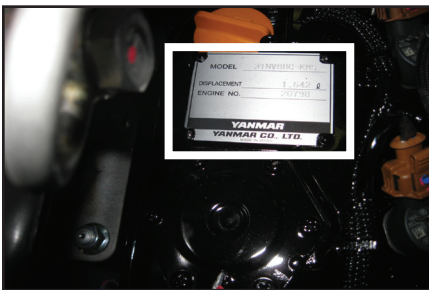

Track Drive Motor Model Number

---

Track Drive Motor Serial Number

---

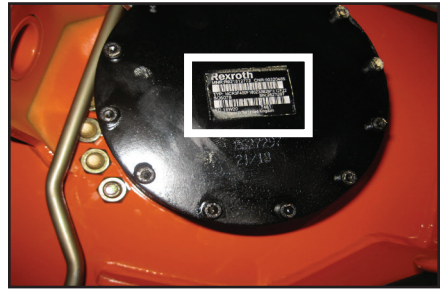

Hydraulic Pump Model Number

---

Hydraulic Pump Serial Number

---



# Introduction

## Component Identification

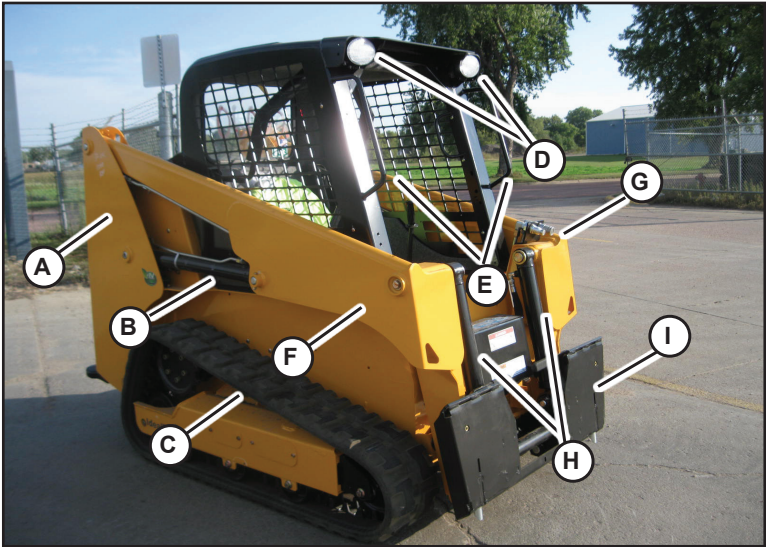
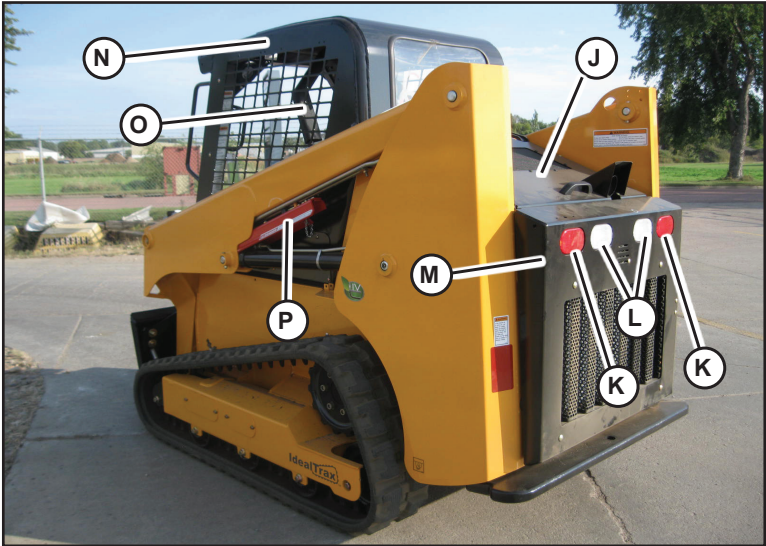

Fig. 1 - Machine Components



Item	Description
A	Upright
B	Lift Cylinder
C	Tracks

Item	Description
D	Front Work Lights
E	Hand holds
F	Lift Arm
G	Auxiliary Hydraulic Couplers
H	Tilt Cylinders
I	Attachment Bracket
J	Engine Cover
K	Tail Lights
L	Rear Work Lights
M	Rear Door
N	Roll-Over/Falling Object Protective Structure (ROPS/FOPS)
O	Restraint Bar
P	Lift Arm Support Device

Table 1 - Component Identification

## List of Attachments

Dirt / Construction Buckets	Weight	Rated Operating Capacity
1372 mm/0.28 m <sup>3</sup> (54.00 in./9.8 ft <sup>3</sup> )	129 kg (285 lbs.)	476 kg (1050 lbs.)
1524 mm/0.31 m <sup>3</sup> (60.00 in./11.0 ft <sup>3</sup> )	138 kg (305 lbs.)	467 kg (1030 lbs.)
1549 mm/0.33 m <sup>3</sup> (61.00 in./11.6 ft <sup>3</sup> )	141 kg (310 lbs.)	465 kg (1026 lbs.)
Pallet Forks	Weight	Rated Operating Capacity
406.4 mm (16.00 in.) Forks with Backrest Rating per EN474-3	213 kg (470 lbs.)	319 kg (704 lbs.)
508 mm (20.00 in.) Forks with Backrest Rating per EN474-3	213 kg (470 lbs.)	229 kg (660 lbs.)
609.6 mm (24.00 in.) Forks with Backrest Rating per SAE J1197	213 kg (470 lbs.)	281 kg (620 lbs.)

Table 2 - List of Attachments

The attachments determine how the machine is used.



# Introduction

---



Contact Edge Attachments (<http://www.edgeattach.com/>) for information about available attachments approved for use with the machine.

**Use of unapproved attachments could result in serious injury or property damage.**

---

Contact Edge Attachments (<http://www.edgeattach.com/>) before using attachments or equipment not approved by Manitou Americas. Use of non-approved attachments or unauthorized modifications is prohibited.

## Using Attachments

Read all documentation provided with attachments to learn how to safely operate and maintain them.

Do not use the machine for any applications or purposes other than those described in this manual or manuals supplied with attachments. Contact your dealer before using attachments or equipment not approved by Manitou Group. Use of non-approved attachments or unauthorized modifications is prohibited..

## Vibration Information

Compact construction equipment is generally used in harsh environments. This type of usage can expose an operator to uncomfortable levels of vibration. It is useful to understand exposure to vibration levels when operating compact equipment and what can be done to reduce vibration exposure. As a result, equipment operation can be more efficient, productive and safe.

An operator's exposure to vibration occurs in two ways:

- Whole-Body Vibration (WBV)
- Hand-Arm Vibration (HAV)

WBV issues are primarily addressed in this manual, because evaluations have shown that operation of mobile compact construction equipment on work sites typically results in HAV levels less than the allowed exposure limit of 2.5 m/s<sup>2</sup>. Member States of the European Union must comply with the Physical Agents (vibration) Directive, 2002/44/EC.

Effective control of vibration exposure for an operator involves more than just vibration levels on the machine. The work site, how the machine is used, and proper training all play important roles in reducing vibration exposure.

Vibration exposure results from:

- Work site conditions.
- How the machine is operated.
- The machine characteristics.

Common causes of high WBV levels:

- Using a machine that is improper for the task.
- Work site with potholes, ruts and debris.
- Improper operating techniques, such as driving too fast.
- Incorrect adjustment of the seat and controls.
- Other physical activities while using the machine.

## Vibration Measurement and Actions

The vibration directive places the responsibility for compliance on employers. Actions that should be followed by employers include:

- Assess the levels of vibration exposure.
- Determine from this assessment if operators will be exposed to vibration levels above the limits stated in the directive.

- Take appropriate actions to reduce operator's exposure to vibration.
- Provide operators with information and training to reduce their exposure to vibration.
- Keep good records and update operations and training on a regular basis.

If the assessment concludes that vibration level exposure is too high, one or more of the following actions may be necessary:

1. Train operators:
  - Perform operations (accelerating, steering, braking, etc.) in a smooth manner.
  - Adjust the controls, mirrors and seat suspension for comfortable operation. Do not make adjustments when the machine is in use.
  - Travel across the smoothest parts of the work site and avoid ruts and potholes.
2. Choose proper equipment for the job:
  - Use machines with the proper power and capacity.
  - Select machines with good suspension seats.
  - Look for controls that are easy to use.
  - Ensure good visibility from the operator's position.
3. Maintain the work site:
  - Smooth ruts and fill potholes in traffic areas whenever possible.
  - Clean up debris frequently.
  - Vary traffic patterns to avoid exposure to rough terrain.
4. Maintain equipment. Check that seat suspension and all controls work smoothly and properly.

## Vibration Levels

See "Vibration Levels" on page 43 for a table listing typical whole-body vibration levels for the machine.

## Fire Extinguisher

An installation location for a fire extinguisher is behind the operator's seat ("Q" on page 11).

**IMPORTANT:** *Installation of a fire extinguisher according to DIN-EN 3 must be performed by an authorized dealer.*

**IMPORTANT:** *Inspect the fire extinguisher at regular intervals as recommended by the fire extinguisher equipment manufacturer(s).*

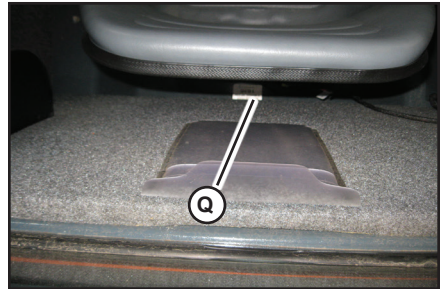

**Fig. 2 - Location for Fire Extinguisher**

**NOTE:** *A fire extinguisher is neither included as standard equipment nor available as an option from Manitou Group.*







## Manufacturer Information





















Products described in this manual are manufactured by Manitou Equipment America.

**NOTE:** *Not all models and options described in this manual are available in all areas.*

# Introduction

## Indicator and Operation Symbols

 Power Off	 Power On	 Engine Start	 Battery Charge	 Electrical Power
 Worklight w/Tail Lights	 Worklight	 Safety Alert	 Hazard Flasher	 Fasten Seatbelt
 Horn	 Read Operator's Manual	 Volume - Full	 Volume - Half Full	 Volume - Empty
 Parking Brake	 Engine Air Filter	 Engine Oil	 Engine Oil Filter	 Engine Oil Pressure
 Fuel Filter	 Engine Temperature	 Hydraulic System	 Hydraulic Oil Temperature	 Hydraulic Oil Filter
 Grease Lubrication Point	 Glow Indicator Lamp	 Diesel Fuel	 Clockwise Rotation	 Counterclockwise Rotation
 Fast	 Slow	 Ride Control	 Engine Malfunction Shutdown	 Bucket - Float
 Bucket - Rollback	 Bucket - Dump	 Lift Arm - Lower	 Lift Arm - Raise	 Service Hours
 Low Fuel Alarm	 Master Light Switch	 Position Lights	 Engine Speed Control	 Engine Power Percentage

 Remove Key	 Crush Hazard	 Pinch Point	 Crush Hazard	 Hot Surface Hazard
 Rotating Fan - Keep Away	 Safety Lock	 Auxiliary Hydraulics Flow	 Fan	 Lift Arm Float
 Hitch Lock	 Hitch Unlock	 Heater	 Engine Temperature	 Critical Error Warning
 Engine Error Code	 Lock	 Unlock	 Front Window Washer	 Rear Window Washer
 Front Window Wiper	 Rear Window Wiper	 Beacon	 Regeneration	 Regeneration Inhibit
 Aftertreatment Error				

# Introduction

---

## Legal Notices

### **Software IP**

Any extraction, decompilation, modification, duplication, or distribution of onboard software is strictly prohibited. Manitou shall have no liability for and hereby disclaims all direct and indirect liability for the consequences resulting from the use of any prohibited onboard software. Contact MANITOU for any request to correct or adapt onboard software for the purposes of interoperability.

### **Data Privacy**

Manitou connected machines are equipped with boxes that collect technical data concerning the machines (such as geolocation, operating, and component data). This data, which is organized, processed, and enriched by Manitou's own algorithms and knowledge, constitutes a protected database in accordance with Article L.341-1 of the French Intellectual Property Code.

It is strictly forbidden to access all or part of this database or to use this data (whether or not intentional) without Manitou's express authorization. In the event that Manitou authorizes an individual to access all or part of this database, Manitou, as producer of this database, only grants the user a personal, non-exclusive, and non-transferrable right to use the database, and only via access to a computer platform hosted on a server owned or controlled by Manitou.

In any case, the following activities are strictly prohibited:

- any extraction, reproduction, representation, reuse by making available to the public, diffusion, or transfer, whether permanent or temporary, on any support, and by any means and in any form whatsoever, of all or a qualitatively or quantitatively substantial part of the contents of the database,
- any extraction, reproduction, representation, reuse by making available to the public, diffusion, transfer, or repeated and systematic extraction of qualitatively or quantitatively insubstantial parts of the contents of the database when these operations clearly exceed the conditions of normal use of the database by the user of the machine for his or her own needs,
- any use of a means of circumventing technical measures for the protection of databases or the source code of the software embedded in the boxes, in accordance with Article L.331-5 of the Intellectual Property Code.

In the event that the above measures are absolutely essential to enable the use of the software, in accordance with its intended purpose, or to obtain the information necessary for interoperability with other independently created software, the user must first contact Manitou, which may, at its sole discretion, take necessary measures or provide access to only the information strictly necessary for interoperability.

Any violation of these prohibitions is likely to constitute an infringement for which Manitou may take legal action.

## Chapter 2

### SAFETY

#### Safety Symbol and Signal Words

This manual and decals on the machine warn of safety hazards and should be read and observed closely.

Manitou Group, in cooperation with the Society of Automotive Engineers, has adopted this:



This symbol is used throughout this operator's manual and on the decals on the machine. It identifies potential safety hazards, which, if not properly avoided, could result in injury. When you see this symbol in this manual or on the machine, you are reminded to **BE ALERT!** Personal safety is involved!

#### Signal Words



The word **"DANGER"** indicates an **imminently hazardous situation, that, if not avoided, will result in serious injury or death.**

---



The word **"WARNING"** indicates a **potentially hazardous situation that, if not avoided, could result in serious injury or death.**

---



The word **"CAUTION"** indicates a **potentially hazardous situation that, if not avoided, may result in minor or moderate injury.**

---

**IMPORTANT:** *The word "IMPORTANT" indicates situations that can result in possible damage to the machine.*

**NOTE:** *The word "NOTE" indicates special or particularly useful information.*

- Before operating the machine, first read and study the safety information in this manual. Be sure that anyone who operates or works on the machine is familiar with the safety precautions. This includes providing translations of the warnings and instructions for operators who are not fluent in reading English.
- It is essential that operators be thoroughly trained in the safe operation of the machine and load handling. Such training should be presented completely to all new operators and not condensed for those claiming previous experience.
- Operators must not be physically or mentally impaired or under the influence of drugs or alcohol. Do not allow minors or unqualified personnel to operate the machine, or to be near the machine unless they are properly supervised. It is recommended that the operator be capable of obtaining a valid motor vehicle operator's license.
- Do not use the machine for any application or purpose other than those described in this manual, or in manuals supplied with any attachments used with the machine.
- Use of the machine is subject to certain hazards that cannot be eliminated by

# Safety

---

mechanical means, but only by exercising intelligence, care and common sense.

Examples of such hazards include but are not limited to: hillside operation, overloading, load instability, poor maintenance, operating too fast for conditions, and using the machine for a purpose for which it was not intended or designed.

- Manitou Group always takes operator's safety into consideration during the design process. Guards and shields are provided, which protect the operator and bystanders from moving parts and other hazards. Operators must be alert, however, because some areas cannot be guarded or shielded without preventing or interfering with proper operation.
- Certain applications may require optional safety equipment. Users must evaluate the work-site hazards and equip the machine and the operator as necessary. The information in this manual does not replace any applicable safety rules and laws. Before operating the machine, learn the rules and laws for the local area. Make sure the machine is equipped as required according to these rules/laws.
- Remember that some risks to your health may not be immediately apparent. Exhaust gases and noise pollution may not be visible, but these hazards can cause permanent injuries.
- Some photographs in this manual may show doors, guards and shields open or removed for the purposes of illustration only. Be sure all doors, guards, shields and panels are secured in the proper operating positions before starting the engine to operate the machine.

## Mandatory Safety Shutdown Procedure

BEFORE cleaning, adjusting, lubricating, fueling, or servicing the machine, or leaving it unattended:

1. Bring the machine to a complete stop on a level surface. If the machine must be parked on a slope, park across the slope and chock the tracks to prevent movement.
2. Be sure all working equipment and/or attachments are stopped and the auxiliary valve is in neutral.
3. Empty the attachment and lower the lift arm and attachment to the ground.
4. Place forward/reverse drive into the neutral position.
5. Apply the parking brake.
6. Move the throttle to the low-idle position and allow the engine to cool.
7. Shut off the engine. Listen for evidence that parts have stopped moving before continuing.
8. Turn the ignition key to the ON/RUN position and move the (multi-purpose) joystick in all directions to verify the hydraulic system is de-pressurized.
9. Press the auxiliary hydraulics pressure relief switch to relieve pressure in the auxiliary hydraulics circuit.
10. Turn off the ignition.
11. Unfasten the seat belt, remove the ignition key and take it with you. Exit the machine using the hand-holds.
12. Always turn the battery disconnect switch to the "OFF" position when parking the machine inside an enclosure.

ONLY when these precautions have been taken can you be sure it is safe to proceed. Failure to follow this procedure could result in death or serious injury.

## Before Starting

- Walk around the machine and inspect it before using it. Refer to "Pre-Start

Checks” on page 73. Look for damage, loose or missing parts, leaks, etc. Repair as required before using the machine.

- Do not remove or modify the Roll-Over Protective Structure/Falling Object Protective Structure (ROPS/FOPS) unless instructed to do so in Manitou Group-approved installation instructions. Modifications, such as welding, drilling or cutting, can weaken the structure and reduce the protection it provides. A damaged ROPS/FOPS cannot be repaired – it must be replaced.
- Unauthorized modifications to the machine can cause injury or death. Never make unauthorized modifications to any part of the machine. Any machine modification made without authorization from Manitou Group could create a safety hazard, for which the machine owner would be responsible.
- For safety reasons, use only genuine service parts. For example, using incorrect fasteners could lead to a condition in which the safety of critical assemblies is dangerously compromised.
- Manitou Group equipment is designed and intended to be used only with Manitou attachments or Manitou-approved attachments. To avoid possible personal injury, equipment damage and performance problems, use only attachments that are approved for use on and within the rated operating capacity of the machine (see “Payloads/Capacities” on page 41). Contact your dealer or Manitou Group for information about attachment approval and compatibility with specific machine models. Manitou Group cannot be responsible if the machine is used with non-approved attachments.
- Optional kits are available through your dealer. Because Manitou cannot anticipate, identify and test all of the attachments owners may want to install on their machines, please contact Manitou Group for information on approval of attachments, and their compatibility with optional kits.
- Remove all trash and debris from the machine every day, especially in the engine compartment, to minimize the risk of fire.
- Always face the machine and use the hand-holds and steps when entering and exiting the machine. Do not jump off the machine. See “Cab Entry and Exit” on page 75.
- Never use ether starting aids. Engine pre-heating is used for cold weather starting. Engine pre-heating can cause ether or other starting fluid to detonate, causing injury or damage.
- Walk around the machine and inspect it before using it. Look for damage, loose or missing parts, leaks, etc. Repair as required before using the machine.
- Warn all nearby personnel before starting the machine.
- Contact the proper local authorities for utility line locations BEFORE starting to dig. In North America, contact the North American One-Call Referral System at 8-1-1 in the U.S., or 1-888-258-0808 in the U.S. and Canada.
- Below-ground hazards also include water mains, tunnels and buried foundations. Know what is underneath the work site before starting to dig.
- Before working near power lines (either above-ground or buried cable type), always contact the power utility and establish a safety plan with them.
- If temperatures are changing, be cautious of dark and wet patches when working or traveling over frozen ground.
- Stay away from ditches, overhangs and other weak support surfaces. Be sure the surrounding ground has adequate strength



# Safety

---

to support the weight of the machine and the load.

- The operator's area, steps and hand holds must be kept free of oil, dirt, ice and unsecured objects.
- If a lighting system is installed, check its operation before working in darkness.
- Always keep windows, lights and mirrors clean. Poor visibility can cause accidents.
- NEVER start the engine if there is any indication that maintenance or service work is in progress, or if a warning tag is attached to the controls.
- Replace damaged safety decals and a lost or damaged operator's manual. Always store this operator's manual in the storage compartment provided for it inside the cab.
- Work crew members should observe and monitor terrain and soil conditions at the work site, along with traffic, weather-related hazards and any above- or below-ground obstacles and hazards.
- Read the operator's manual provided with each attachment before using it.
- Adjust the seat to allow full actuation of all controls. Never adjust the seat during machine operation.
- ALWAYS wear appropriate personal protective equipment for the job and working conditions. Hard hats, goggles, protective shoes, gloves, reflector-type vests, respirators, and ear protection are examples of types of equipment that may be required. DO NOT wear loose fitting clothing, long hair, jewelry or loose personal items while operating or servicing the machine.

## During Operation

- ALWAYS fasten the seat belt securely and properly. Never operate the machine without the seat belt fastened around the operator.
- Only start the engine and only operate the controls while seated in the operator's seat.
- Wear safety goggles, ear and head protection, and any other protective clothing or equipment as needed while operating the machine.
- Always keep hands and feet inside the operator's compartment while operating the machine.
- Check indicators and displays for normal conditions after starting the engine. Check the operation of the controls. Listen for unusual sounds and remain alert for other potentially hazardous conditions.
- If the engine should stall for any reason during operation, always turn the ignition key all the way counter-clockwise to the "OFF" position before re-starting the engine.
- Operator visibility is limited in certain areas; ROPS/FOPS posts, attachments, the lift arm, items in the cab, etc., can obstruct the operator's view and could mask hazards or people in the area around the machine. It is very important the operator is aware of these masked visibility areas before operating the machine, especially on busy work sites.
- To reduce the hazards posed by masked visibility areas:
  - Use caution when raising or lowering attachments; masked visibility areas can change dramatically when attachments and/or the lift arm is moved.
  - Look around the machine before operating. Objects near the machine

- and close to the ground can be difficult to see from the cab.
- Always look in the direction of travel, including reverse. A back-up alarm is not a substitute for looking behind you when operating the machine in reverse.
  - Keep bystanders out of and away from the work area.
  - Keep the lift arm as low as possible while traveling. See “Lift Arm Travel Position” on page 90.
  - Control the machine cautiously until fully familiar with all the controls and handling.
  - Carry the load low. Move the controls smoothly and gradually, and operate at speeds appropriate for the conditions.
  - New operators must learn to operate the machine in an open area away from bystanders. Practice with the controls until the machine can be operated safely and efficiently.
  - Do not overload the machine. See “Payloads/Capacities” on page 41 for load limits. Be aware that effective operating capacity is reduced when the machine is turned.
  - Do not raise or drop a loaded bucket or attachment suddenly. Abrupt movements under load can cause serious instability.
  - DO NOT ram the lift cylinder to the end of the stroke. The resulting jolt could spill the load.
  - Do not use the machine to lift or transport people. Never carry riders. Do not allow others to ride on the machine or attachments, because they could fall or cause an accident.
  - Never leave the operator’s seat without lowering the lift arm/attachment flat on the ground or engaging the lift arm support device(s), and then stopping the engine and removing the ignition key.
  - Stop the engine and place the controls in the lock-out position before mounting attachments. Check that attachments are securely fastened to the lift arm before working.
  - Be aware that attachments affect the handling and balance of the machine. Adjust the operation of the machine as necessary when using attachments.
  - Before coupling or uncoupling the hydraulic lines for the attachment, stop the engine and press the auxiliary hydraulics pressure relief switch to relieve pressure in the auxiliary hydraulics circuit.
  - Make sure the bucket is lowered to the ground before activating the lift arm float. Never activate the float function with the bucket or attachment raised, because this will cause the lift arm and bucket or attachment to drop suddenly.
  - Be aware of overhead obstacles. Any object near the lift arm could represent a potential hazard, or cause the operator to react suddenly and cause an accident. Use a spotter or signal person when working near bridges, phone lines, work site scaffolds, or other obstructions.
  - Do not place limbs near moving parts. Severing of body parts can result.
  - Exhaust fumes can kill. Do not operate the machine in an enclosed area without adequate ventilation. Internal combustion engines deplete the oxygen supply within enclosed spaces and may create a serious hazard unless the oxygen is replaced.
  - Operators should be aware of any open windows, doors or duct work into which exhaust gases may be carried, exposing others to danger.
  - Never allow anyone under a raised lift arm. Lowering the lift arm or a falling load can result in death or serious personal injury.
  - Avoid slowing suddenly while carrying a load. Sudden slowing can cause the load

# Safety

---

- to fall off the attachment, or cause the machine to tip over.
- Slow down the work cycle and use slower travel speeds in congested or populated areas. Use commonly understood signals so other members of the work crew can warn the operator to slow or halt work in a potentially hazardous situation.
- Use a signal person if you cannot see the entire work area clearly, in high traffic areas and whenever the operator's view is not clear.
- Stay alert for people moving through the work area. When loading a truck, the operator should always know where the driver is.
- Exposed hydraulic hoses could react with explosive force if struck by falling or overhead items. NEVER allow hoses to be hit, bent or interfered with during operation. Extra guards may be required. Replace any damaged hoses.
- Do not move the lift arm or attachment during transport. Use the hydraulics lockout button to deactivate the lift and tilt hydraulics during transport.
- Do not use the machine in an environment where the hot muffler could present a fire hazard, such as hay or straw storage facilities.
- To avoid being thrown forward and injured, do not drive into materials at high speeds.
- Do not turn off the ignition switch while traveling. Turning off the ignition will cause sudden braking, which may cause loss of control, injury and/or tipping of the machine.
- Be sure no one enters the work area of the machine. Anyone near the machine is at risk of being injured.
- Unless necessary for servicing the machine, the engine hood must not be opened while the engine is running.
- In cold weather, avoid sudden travel movements and stay away from even slight slopes. The machine can slide sideways on icy slopes.
- Snow accumulation can hide potential hazards. Use care while operating and while using the machine to clear snow.
- If the machine becomes damaged or malfunctions, stop the machine immediately and lock and tag it. Repair the damage or malfunction before using the machine again.
- Never jump off the machine. Always leave the machine using the steps and hand-holds. Never get on or off a moving machine.
- If unable to exit out the front of the cab, remove the rear window by pulling the emergency rear window release triangle until the window seal is pulled out of the window frame, then push the window out of the frame.

## Applications with Load-Handling Devices

- Specific procedures are required, when using load-handling devices (e.g., slings, chains) for transporting and placing loads. For example, assistance from other people is needed when lifting and lowering pipes, culverts or containers:
- The machine may only be used with load-handling devices if the necessary safety devices are in place and functional.
- The load must be secured to prevent it from falling or slipping.
- Persons guiding the load must stay in visual contact with the operator.
- The operator must guide the load to the ground as soon as possible while staying out from under the loader, load and out of harm's way. Avoid any rotating or swinging movements. Tag lines may be required.

- The machine may be moved with a raised load only if the path of the machine is level.
- Persons attaching or securing loads may only approach the machine from the side, after the operator has given permission. The operator may only give permission after the machine and the attachment are stationary.
- Do NOT use any lifting attachments (slings, chains) that are damaged or of inadequate rated capacity.

## Parking the Machine

- When shutting down the machine for the day, plan ahead so the machine will be on a firm, level surface away from traffic and away from high-walls, cliff edges and any area of potential water accumulation or runoff. Lower the attachment and lift arm to the ground. There should be no possibility of unintended or accidental machine movement.
- If the machine must be parked on a slope, park across the slope and chock the tracks to prevent movement.
- To avoid collisions when parking on streets, use barriers, caution signs, lights, etc., so that the machine can be easily seen at night.
- After the machine has been parked properly, shut down the machine according to the “Mandatory Safety Shutdown Procedure” on page 18.

## Electrical Energy

- Stay away from high-voltage lines. Electrocutation can result from contact or proximity to high-voltage electric lines. The machine does not have to make physical contact with power lines for current to be transmitted. Use a spotter and hand signals to keep away from power lines not clearly visible to the operator.
- If the machine comes into contact with a live wire:
  - Do not leave the machine.
  - If possible, drive the machine out of the danger area.
  - Warn others not to approach or touch the machine.
  - Have the live wire de-energized.
  - Do not leave the machine until the wire has been safely de-energized.
- Depending upon the voltage in the power line and atmospheric conditions, strong electric shocks can occur if the machine is closer than 3 m (10 ft.) from the power line. Higher voltages and rainy weather can further increase the safe operating distance.
- Work on the machine’s electrical system must be performed only by trained technicians.
- Inspect and check the machine’s electrical equipment at regular intervals. Problems found, such as loose connections or scorched cables, must be repaired before using the machine.
- Only use proper, original equipment fuses/circuit breakers with the specified current rating. Turn off the machine immediately if there is any indication of a problem with the electrical system.

# Safety

---

## Maintenance and Service Safety Practices

- Only trained and authorized personnel, with a full awareness of safe procedures, should be allowed to operate or perform maintenance or service on the machine.
  - Use warning tag/control lockout procedures during service. Alert others that service or maintenance is being performed by tagging the operator's controls — and other machine areas if required — with a warning notice.
  - Always lower lift arm or elevated items, or securely support/secure them, before performing any maintenance or service on the machine.
  - Use solid support blocking. Never rely on jacks or other inadequate supports when maintenance work is being done. Never work under any equipment supported only by jacks.
  - Do not use the lift or tilt hydraulics to lift or support the machine for maintenance or service.
  - Never allow anyone under the raised lift arm. Disconnecting or loosening any hydraulic line, hose, fitting or component, parts failure, and venting hydraulic pressure all can cause the lift arm to drop.
  - Never attempt to bypass the ignition key switch to start the engine. Use only the proper jump-starting procedure according to “Jump-Starting” on page 94.
  - Never use hands to search for hydraulic oil leaks. Instead, use a piece of paper or cardboard. Escaping fluid under pressure can be invisible and can penetrate the skin, causing serious injury. If any fluid is injected into your skin, see a doctor immediately. Injected fluid must be surgically removed by a doctor or gangrene may result.
  - Always wear safety glasses with side shields when striking metal against metal.
- In addition, it is recommended that a softer (chip-resistant) material be used to cushion the blow, otherwise, serious injury to the eyes or other parts of the body could result.
- Use care when seating retainer pins — retainer pins can fly out or splinter when struck and could cause injury.
  - Do not smoke or have any spark- or flame-producing equipment or materials in the area while filling the fuel tank or working on the fuel or hydraulic systems.
  - Do not attempt to loosen or disconnect any hydraulic lines, hoses, fittings, covers or caps without first relieving hydraulic circuit pressure. Relieve hydraulic pressure by performing the “Mandatory Safety Shutdown Procedure” on page 18 and slowly loosening the hydraulic reservoir filler cap. Be careful not to touch any hydraulic components that have been in recent operation. Failure to heed this warning could result in severe burns.
  - Do not attempt to remove the radiator cap after the engine has reached operating temperature or if it is overheated. At operating temperatures, engine coolant is extremely hot and under pressure. Always wait for the engine to cool before attempting to relieve pressure and remove the radiator cap. Failure to heed this warning could result in severe burns.
  - Refer to the parts manual for information about assembly of components. Always use the correct parts and the proper torques — incorrect fastener connections can dangerously weaken assemblies.
  - Do not run the engine if repairs are being performed alone. There should always be at least 2 people present if the engine must be run during service. Both persons must maintain visual contact with each other. Keep a safe distance away from all rotating and moving parts.

- Always use proper tools while working on the machine. Incorrect tools could break or slip, causing injury, or they may not adequately perform intended functions.
- Unless necessary for servicing the machine, do not open the engine cover while the engine is running.
- Do not use the machine when maintenance is scheduled to be performed. Postponing maintenance can result in a serious reduction of the service life of the machine, more serious and costly equipment failures, and contribute to unsafe operating conditions.
- Only tow the machine as described in this manual. See “Towing” on page 121.
- Do not work on hot engines, cooling systems or hydraulic systems. Wait for the engine to cool. When engine lubrication oil, gearbox lubricant or other fluids require changing, wait for fluid temperatures to decrease to a moderate level before removing drain plugs.

**NOTE:** *Temperatures below 49°C (120°F) will reduce the chances of scalding exposed skin while allowing the fluid to drain quickly and completely. Do not let the fluid fully cool, because drain time will be substantially increased.*

- Dispose of all oils and fluids properly. Used oils/fluids are environmental contaminants and may only be disposed of at approved collection facilities. Never drain any oils/fluids onto the ground, dispose of in municipal waste collection containers, or in metropolitan sewer systems or landfills. Check state and local regulations for other requirements.
- All safety equipment must be maintained so it is always in good condition.
- Safety-critical parts must be periodically replaced. Replace the following

potentially fire-related components as soon as they begin to show signs of deterioration:

- Fuel system flexible hoses, fuel tank overflow drain hose and the fuel filler cap.
- Hydraulic system hoses, especially the pump outlet lines. Replace hydraulic hoses every 6 years from the date of manufacture, even if they do not appear damaged. The date of manufacture (month or quarter and year) is indicated on the hydraulic hoses.
- Keep mounting brackets and hose and cable routing straps tight. Hose routing should have gradual bends.
- After cleaning the machine, examine all fuel, lubricant and hydraulic oil lines for leaks, chafe marks and damage. Tighten any loose connections and repair or replace parts as necessary.

**IMPORTANT:** *When washing the machine using water, do not direct the water onto any electrical connection, electrical component, or electronic component. Water may cause malfunction or damage. Power washing or other high-pressure jets may cause physical damage.*

- Hydraulic lines and hoses must be routed and fitted properly. Make sure no connections are interchanged.
- When handling oil, grease and other chemical substances, follow the product-related safety requirements Material Safety Data Sheet (MSDS) carefully to prevent burning or scalding.

# Safety

---

## Battery Hazards

- Use the battery disconnect switch, or disconnect the negative battery cable from the negative battery terminal, before performing electrical service or electrical welding on the machine.
- Do not use a battery when the fluid level is below the minimum level. Doing so will hasten the deterioration of the battery and shortens battery life, and can also cause rupturing or explosion.
- Turn off all electrical equipment before connecting leads to the battery, including electrical switches on the battery charger or jump-starting equipment.
- When disconnecting at the battery terminals, remove the cable connected to the negative terminal first. When installing a battery, connect the positive terminal cable first.
- Connect the positive (+) cable first when installing jumper cables. The final cable connection, at the metal frame of the machine being charged or jump-started, should be as far away from the battery as possible. Disconnect the negative (-) cable first when removing jumper cables.
- Sparks and open flames can ignite explosive battery gas from incidental contact or static discharge. Turn off all switches and the engine when working on batteries. Keep battery terminals tight. Contact between a loose cable clamp and a terminal post can create an explosive spark.
- When jump-starting from another machine, do not allow the machines to touch. Wear safety glasses or goggles when battery connections are made.
- Never jump-start the machine if it has a frozen battery. The battery could explode. Thaw a frozen battery before charging it or attaching jumper cables.
- Flush eyes with water for 10-15 minutes if battery acid is splashed in the face.

Anyone swallowing battery acid must have immediate medical aid. Call the Poison Control Center at 1-800-222-1222 in the United States.

## Fire Hazards

- The machine must be cleaned on a regular basis to avoid the buildup of flammable debris, such as leaves, straw, etc. Accumulated debris, particularly in the engine compartment, creates a fire hazard.
- The machine has several components that operate at high temperatures under normal operation conditions, primarily the engine and exhaust systems. Also, the electrical system, if not properly maintained or if damaged, can arc or produce sparks. These conditions make it extremely important to avoid circumstances where explosive dust or gases can be ignited by arcs, sparks or heat.
- It is recommended that a 2.27 kg (5 lb.) or larger, multi-purpose “A/B/C” fire extinguisher be mounted in the cab. Check the fire extinguisher periodically and be sure that work crew members are trained in its use.
- Add fuel, oil, antifreeze and hydraulic oil to the machine only in a well ventilated area. The machine must be parked with controls, lights and switches turned off. The engine must be turned off before refueling or performing service checks.
- Do not smoke while filling the fuel tank, while working on the fuel or hydraulic systems, or while working around the battery.
- Always immediately replace the fuel filler cap after refueling. Keep fuel and other fluid reservoir caps tight. Do not start the engine until caps have been secured.
- Avoid spilling combustible fluids, such as oil or fuel, on a hot engine.
- Static electricity can produce dangerous sparks at the fuel-filling nozzle. Do

not wear polyester, or polyester-blend clothing while fueling. Before fueling, touch the metal surface of the machine away from the fuel fill to dissipate any built-up static electricity. Do not re-enter the machine but stay near the fuel filling point during refueling to minimize the build-up of static electricity. Do not use cell phones while fueling. Make sure the static line is connected from the machine to the fuel truck before fueling begins.

- Ultra-Low Sulfur Diesel (ULSD) poses a greater static ignition hazard than earlier diesel formulations. Avoid death or serious injury from fire or explosion; consult with your fuel or fuel system supplier to ensure the entire fuel delivery system is in compliance with fueling standards for proper grounding and bonding practices.
- Oil from leaks can ignite on hot components. Repair any damaged or leaking components before using the machine.

## Additional Safety Equipment

- Certain operations require use of additional safety equipment. Install additional safety equipment if conditions require. For example, when using a hydraulic breaker, a polycarbonate front window may be required.
- Never attempt to alter or modify the protective structure by drilling holes, welding or re-locating fasteners. Any serious impact or damage to the system requires a complete integrity re-evaluation, and the replacement of the system may be necessary.
- Laminated glass or polycarbonate protection for the front, side or rear windows may also be required, depending upon particular work conditions.
- Contact your dealer for available safety guards if there is any risk of objects striking the operator's cab.

## Crystalline Silica Exposure

Exposure to crystalline silica (found in sand, soil and rocks) has been associated with silicosis, a debilitating and often fatal lung disease. Comply with all applicable rules and regulations for the work place. Wear approved respiratory protection or use water spray or other means if there is no other way to control the dust.

A Silica rule “29 CFR 1929.1153” by the U.S. Occupational Safety and Health (OSHA) indicates a significant risk of chronic silicosis for workers exposed to inhaled crystalline silica over a working lifetime. Refer to the rule for more information regarding exposure limits and hazard prevention.







## EC DECLARATION OF CONFORMITY

1. Manufacturer: **Manitou Equipment America, LLC**
2. Address: **One Gehl Way  
West Bend, WI 53095 U.S.A**
  
3. Technical Construction File Location: **Manitou Interface and Logistics Europe**
  
4. Authorized Representative: **Manitou Interface and Logistics Europe**
5. Address: **Rue DesAndains 2  
Perwez, 1360  
Belgium**
  
6. **We hereby declare that the machine listed below conforms to EC Directives: 2014/30/EU (EMC), 2006/42/EC (Machinery) and 2000/14/EC (Noise Emission), as amended by 2005/88/EC.**
7. In accordance with EN/ISO Standards: **EN474-1 and EN474-3**
8. Designation: **EARTH-MOVING MACHINERY/LOADERS/COMPACT**
9. Model: **1050RT**
10. Serial Number:
11. Net Installed Power - KW
12. Sound Power Levels – (measured): - dB(A)  
(guaranteed): - dB(A)
13. Directive / Conformity Assessment Procedure / Notified Body:

<b>2000/14/EC</b>	<b>Annex VIII, full Quality Assurance</b>	<b>TÜV Industrie Service GmbH – TÜV SÜD Group Westendst. 199, D-80686 München GERMANY</b>
-------------------	---	---

14. Name:
15. Position/Title:
16. (Signature)
17. Place:
18. Date:

The EC Declaration of Conformity document was provided with the machine if it is manufactured to comply with specific requirements of European Union. Please refer the individual Declaration of Conformity issued with the machine for exact details.

# Chapter 3

## DECALS

### General Information

- The machine has decals that provide safety information and precautions. These decals must be kept legible. If missing or illegible, they must be replaced promptly. Replacements can be obtained from your dealer.
- Refer to the Parts Manual for decal part numbers and ordering information.

decal. Remove the smaller portion of the decal backing paper and apply the exposed adhesive to the clean surface, maintaining proper position and alignment. Peel the rest of the backing paper and apply hand pressure to smooth out the decal surface. Refer to the following pages for proper decal locations.

- If replacing a part that has a decal on it, ensure that the replacement part has the same decal.

### New Decal Application

- Surfaces must be free of dirt, dust, grease and foreign material before applying the

### Decal Locations

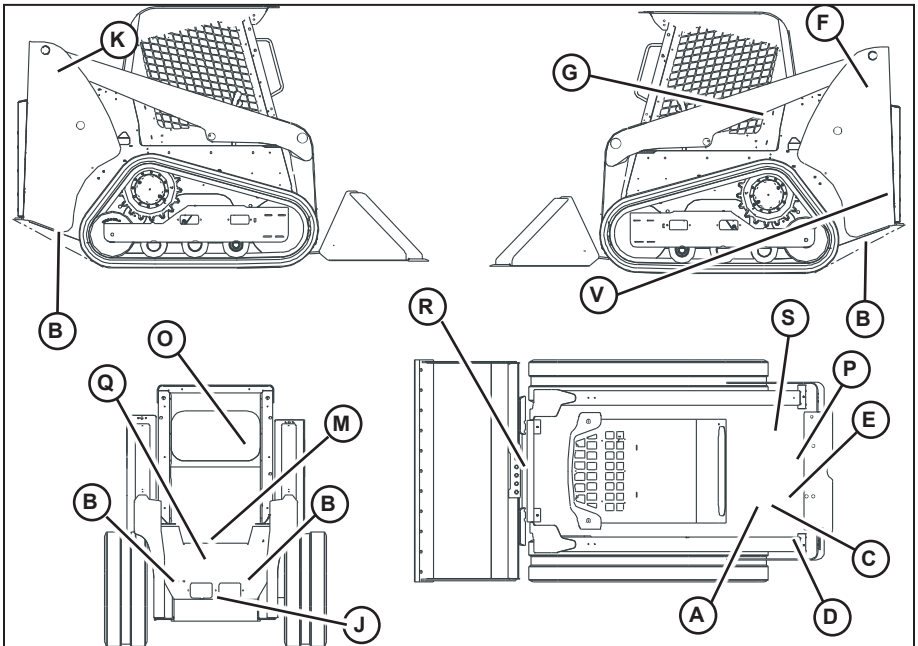

Fig. 3 - Safety and Information Decal Locations Around the Machine

# Decals

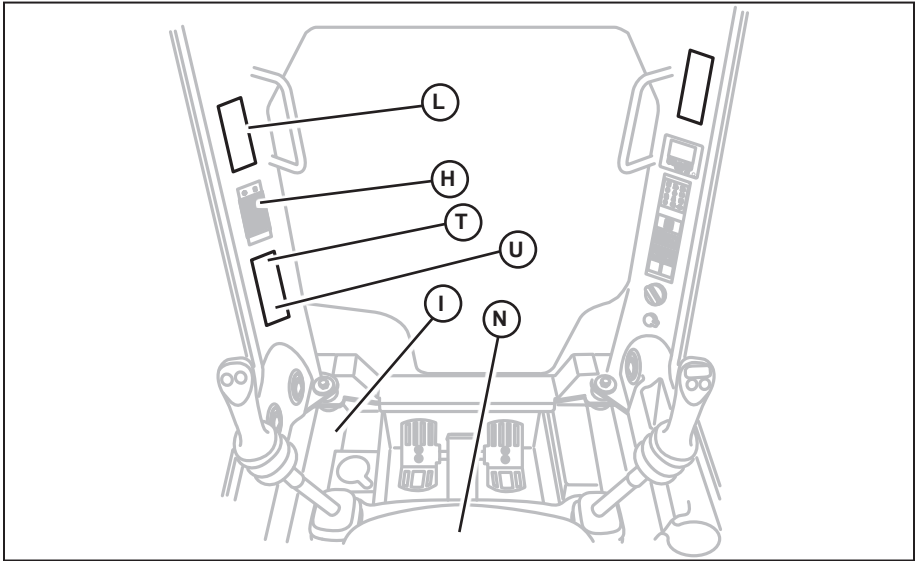

Fig. 4 - Safety and Information Decals Inside the Cab

## Common Decals

A



(Located next to the fuel filler neck)

USE PROPER DIESEL FUEL ONLY!

B

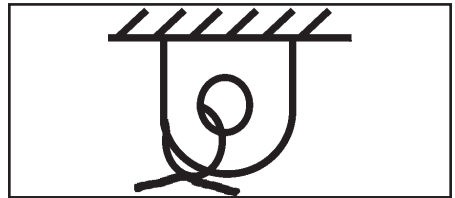

(Located on the bottom of the side panels behind the tracks (both sides), and at the front of each pontoon on the outside face (both sides))

Tie-down point. Only use tie-down points indicated on machine when transporting machine.

C

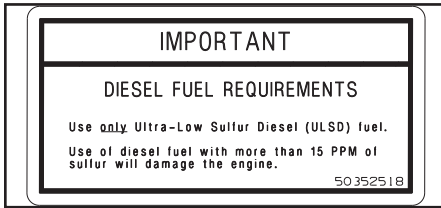

(Located near the fuel filler neck)

**IMPORTANT: DIESEL FUEL REQUIREMENTS:**

- Use only Ultra-Low Sulfur Diesel (ULSD) fuel.
- Use of diesel fuel with more than 15 PPM of sulfur will damage the engine.

D

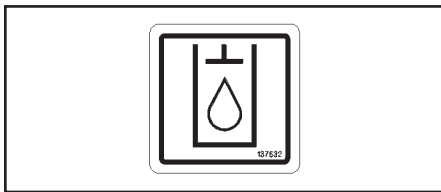

(Located near the hydraulic fluid reservoir filler neck)

**USE PROPER HYDRAULIC FLUID ONLY!**

E

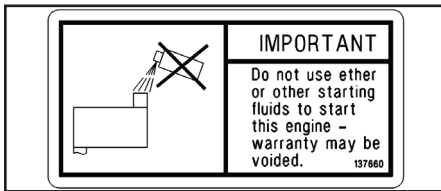

(Located inside the engine compartment)

**IMPORTANT:**

- Do not use ether or other starting fluids to start this engine — warranty may be voided.

F

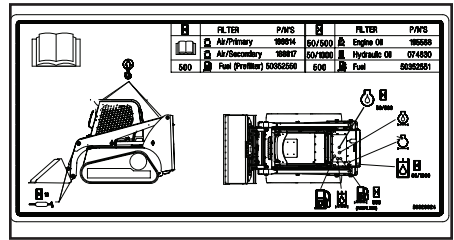

(Located on the inside of the left lift arm pillar.)

Service Decal

**ANSI-Style Decals**

G

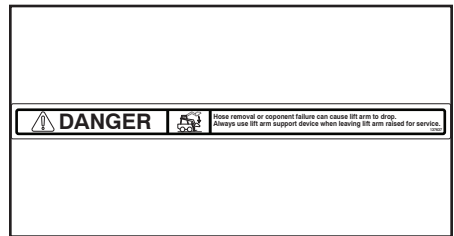

(Located on lift arm support device, machine left side)

**WARNING: Crush Hazard**

- Be sure lock mechanism is securely engaged before working under ROPS/FOPS. Read instructions for use in Operator's Manual.

H

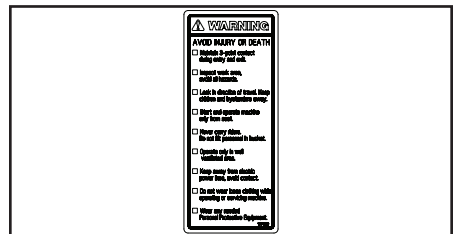

(Located on ROPS/FOPS left panel)

**WARNING: AVOID INJURY OR DEATH**

- Maintain 3-point contact during entry and exit

# Decals

- Inspect work area; avoid all hazards
- Look in the direction of travel; Keep children and bystanders away.
- Start and operate machine only from the operator’s seat.
- Never carry riders; Do not lift personnel in bucket.
- Operate only in well-ventilated area.
- Keep away from electric power lines, avoid contact.
- Do not wear loose clothing while operating or servicing machine.
- Wear any needed Personal Protective Equipment.

I

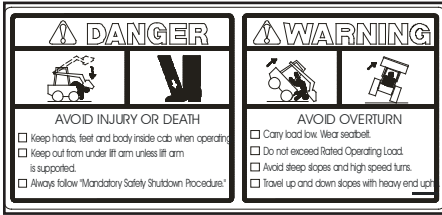

(Located near left operator’s foot)

**DANGER: AVOID INJURY OR DEATH**

- Keep hands, feet and body inside cab when operating.
- Keep out from under lift arm unless lift arm is supported.
- Always follow “Mandatory Safety Shutdown Procedure”

**WARNING: AVOID OVERTURN**

- Carry load low; Wear seat belt.
- Do not exceed Rated Operating Load.
- Avoid steep slopes and high speed turns.
- Travel up and down slopes with heavy end uphill.

J



(Located on front of the machine)

**DANGER: AVOID INJURY OR DEATH**

- Keep out from under work tool, unless lift arm is supported.
- No riders! Never use work tool as work platform.

K



(Located on the right rear riser)

**WARNING: AVOID INJURY OR DEATH**

- Keep safety devices working.
- Jump start per Operator’s Manual procedure.
- Clean debris from engine compartment daily to avoid fire. Keep fire extinguisher nearby.
- Do not use hands to find hydraulic leaks. Escaping oil under pressure can be invisible and penetrate skin.
- Allow radiator to cool before removing cap. Loosen cap slowly to avoid burns.
- Keep guards, screens and windows in place.
- Do not smoke while fueling or servicing machine.

L



(Located on ROPS/FOPS left panel)

**WARNING: AVOID INJURY OR DEATH**  
Always follow “Mandatory Safety Shutdown Procedure.”

- 1) Lower equipment to ground.
- 2) Reduce throttle, stop engine.
- 3) Apply brake; remove key.
- 4) Check safety interlocks.

M



(Located under the ROPS/FOPS seat pan)

**WARNING: Crush Hazard**

- Be sure lock mechanism is securely engaged before working under ROPS/FOPS.
- Read instructions for use in Operator's Manual.

O

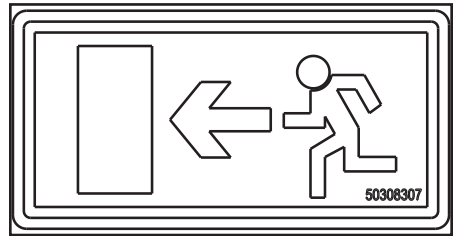

(Located on the rear window)

Designates emergency egress location.

N



(Located behind the operator's seat)

**WARNING: AVOID INJURY OR DEATH**

- Read Operator's Manual and all safety signs before using machine.
- The owner is responsible to ensure all users are instructed on safe use and maintenance.
- Check machine before operating; Service per Operator's Manual.
- Contact dealer (or manufacturer) for information and service parts.

P

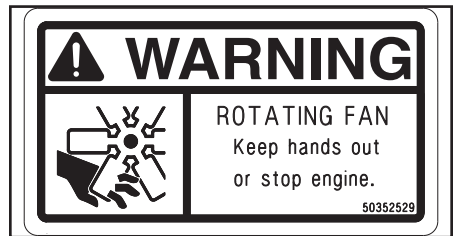

(Located on the fan shroud, inside the engine compartment)

**WARNING: ROTATING FAN**

- Keep hands out or stop engine.

Q



(Located on the front of the machine)

**WARNING: AVOID INJURY OR DEATH**

- Before operating with attachment, check engagement of loader attachment bracket locking pin to the attachment.

# Decals

R

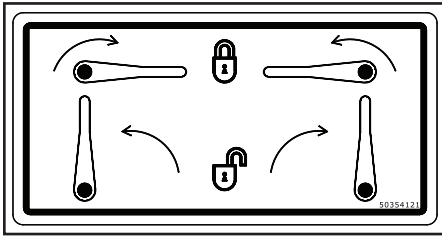

(Located on the front of the machine)

**WARNING: AVOID INJURY OR DEATH**

- Before operating with attachment, check engagement of loader attachment bracket locking pin to the attachment.

S

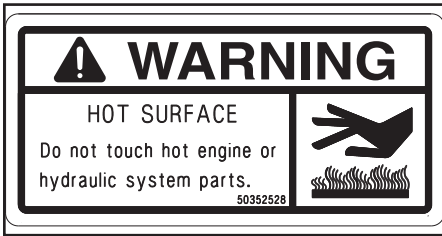

(Located on the fuel tank, inside the engine compartment)

**WARNING: HOT SURFACE**

- Do not touch hot engine or hydraulic system parts.

T



(Located on ROPS/FOPS left panel)

**WARNING:**

- This product can expose you to lead which is known to the State of California to cause cancer and birth defects or other reproductive harm.

U

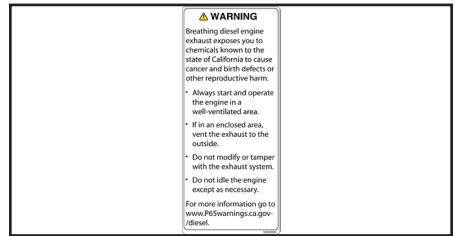

(Located on ROPS/FOPS left panel)

**WARNING:**

- Breathing diesel engine exhaust exposes you to chemicals known to the State of California to cause cancer and birth defects or other reproductive harm.
- Always start and operate the engine in a well-ventilated area.
- If in an enclosed area, vent the exhaust to the outside.
- Do not modify or tamper with the exhaust system.
- Do not idle the engine except as necessary.

V

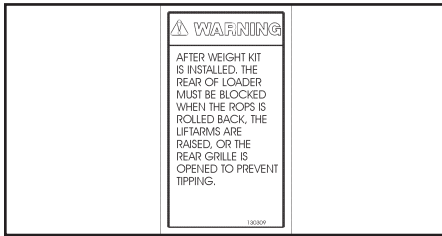

(Located on the rear face of the lower left riser)

**WARNING:**

After weight kit is installed, the rear of loader must be blocked when the ROPS is rolled back, the lift arms are raised, or the rear grill is opened to prevent tipping.

**ISO-Style Decals**

G

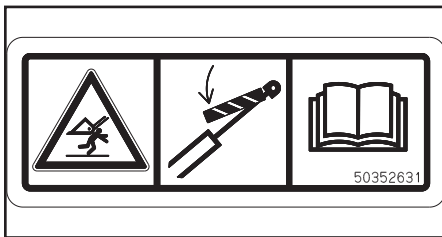

(Located on lift arm support device, machine left side)

**WARNING: Crush Hazard**

- Be sure lock mechanism is securely engaged before working under ROPS/FOPS. Read instructions for use in Operator's Manual.

H



(Located on ROPS/FOPS left panel)

**WARNING: AVOID INJURY OR DEATH**

- Maintain 3-point contact during entry and exit
- Inspect work area; avoid all hazards
- Look in the direction of travel; Keep children and bystanders away.
- Start and operate machine only from the operator's seat.
- Never carry riders; Do not lift personnel in bucket.
- Operate only in well-ventilated area.
- Keep away from electric power lines, avoid contact.
- Do not wear loose clothing while operating or servicing machine.
- Wear any needed Personal Protective Equipment.

I



(Located near left operator's foot)

**DANGER: AVOID INJURY OR DEATH**

- Keep hands, feet and body inside cab when operating.
- Keep out from under lift arm unless lift arm is supported.
- Always follow "Mandatory Safety Shutdown Procedure"

**WARNING: AVOID OVERTURN**

- Carry load low; Wear seat belt.



# Decals

- Do not exceed Rated Operating Load.
- Avoid steep slopes and high speed turns.
- Travel up and down slopes with heavy end uphill.

J

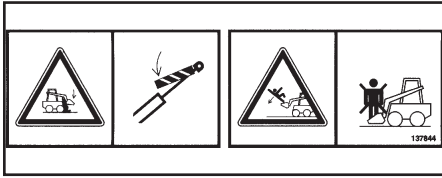

(Located on front of the machine)

**DANGER: AVOID INJURY OR DEATH**

- Keep out from under work tool, unless lift arm is supported.
- No riders! Never use work tool as work platform.

K



(Located on the right rear riser)

**WARNING: AVOID INJURY OR DEATH**

- Keep safety devices working.
- Jump start per Operator’s Manual procedure.
- Clean debris from engine compartment daily to avoid fire. Keep fire extinguisher nearby.
- Do not use hands to find hydraulic leaks. Escaping oil under pressure can be invisible and penetrate skin.
- Allow radiator to cool before removing cap. Loosen cap slowly to avoid burns.
- Keep guards, screens and windows in place.
- Do not smoke while fueling or servicing machine.

L

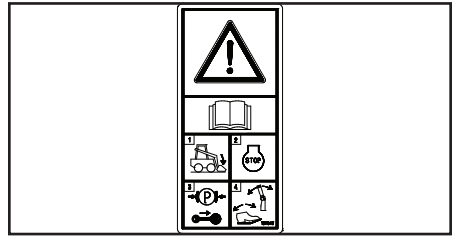

(Located on ROPS/FOPS left panel)

**WARNING: AVOID INJURY OR DEATH**  
Always follow “Mandatory Safety Shutdown Procedure.”

- 1) Lower equipment to ground.
- 2) Reduce throttle, stop engine.
- 3) Apply brake; remove key.
- 4) Check safety interlocks.

M



(Located under the ROPS/FOPS seat pan)

**WARNING: Crush Hazard**

- Be sure lock mechanism is securely engaged before working under ROPS/FOPS.
- Read instructions for use in Operator’s Manual

N

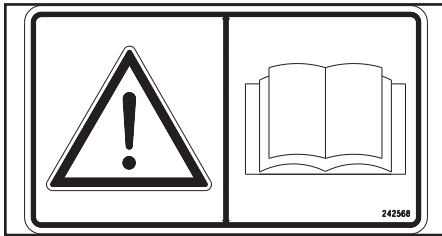

(Located behind the operator's seat)

**WARNING: AVOID INJURY OR DEATH**

- Read Operator's Manual and all safety signs before using machine.
- The owner is responsible to ensure all users are instructed on safe use and maintenance.
- Check machine before operating; Service per Operator's Manual.
- Contact dealer (or manufacturer) for information and service parts.

N



(Located on lift arm support device, machine left side)

**WARNING: Crush Hazard**

- Be sure lock mechanism is securely engaged before working under ROPS/FOPS. Read instructions for use in Operator's Manual.

O

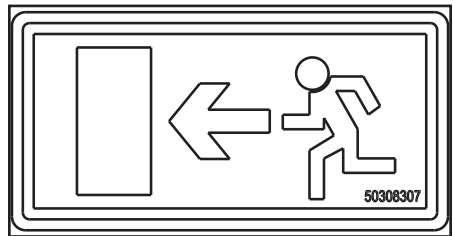

(Located on the rear window)

Designates emergency egress location.

M

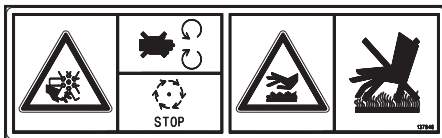

(Located on the fuel tank, inside the engine compartment)

**WARNING: ROTATING FAN**

- Keep hands out or stop engine

**WARNING: HOT SURFACE**

- Do not touch hot engine or hydraulic system parts.

P

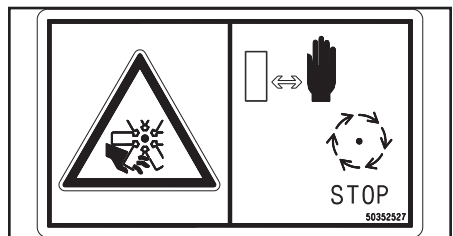

(Located on the fan shroud, inside the engine compartment)

**WARNING: ROTATING FAN**

- Keep hands out or stop engine.

# Decals

Q

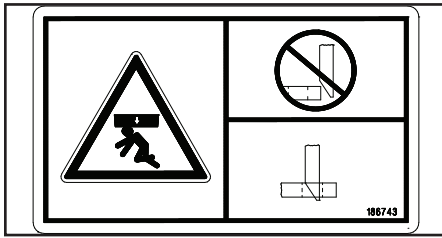

(Located on the front of the machine)

**WARNING: AVOID INJURY OR DEATH**

- Before operating with attachment, check engagement of loader attachment bracket locking pin to the attachment.

S

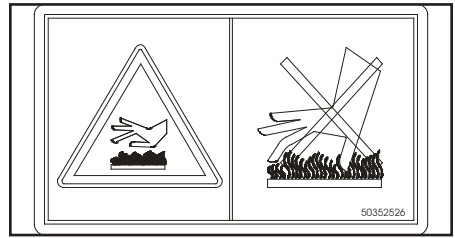

(Located on the fuel tank, inside the engine compartment)

**WARNING: HOT SURFACE**

- Do not touch hot engine or hydraulic system parts.

Q

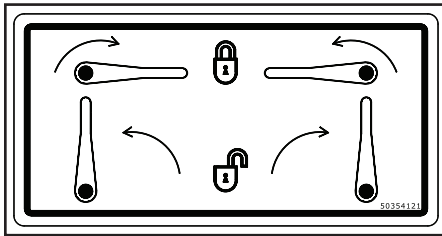

(Located on the front of the machine)

**WARNING: AVOID INJURY OR DEATH**

- Before operating with attachment, check engagement of loader attachment bracket locking pin to the attachment.

R



(Located on the front of the machine)

**WARNING: AVOID INJURY OR DEATH**

- Before operating with attachment, check engagement of loader attachment bracket locking pin to the attachment.

# Chapter 4

## SPECIFICATIONS

### Fluids/Lubricants Types and Capacities

For information about fluids and lubricants, including types, capacities, and other specifications, refer to the Lubrication Section on page 101.

Component/Application	Type	Quantity
Hydraulic Oil Reservoir Tank	XPRT™, or Petro Canada HVI60, Mobil	30.0 L (8 U.S. gallons)
Hydraulic System – Total	DTE 15M or equivalent, which contain anti-rust, anti-foam and anti-oxidation additives, and conforms to ISO VG46.	37.9 L (10 U.S. gallons)
Final Drives: Motor		345 - 375 ml (0.36 - 0.39 qt.) + 10%
Grease Fittings, Lift Arm/Hitch	Lithium-saponified, brand-name multi-purpose grease MPG-A	As required
Battery Terminals	SP-B acid-proof grease	As required
Diesel Fuel Tank (DPF) / (Non-DPF)	Tier 4 engines: ULSD <sup>1</sup> low sulfur or ultra-low sulfur, below 15 PPM.	36 L (9.5 U.S. gallons) (DPF) / 39 L (10.3 U.S. gallons) (Non-DPF)
Engine Coolant	Long life coolant ASTM D4985, D6210 (United States) SAE J814C, J1941, J1034 or J2036 (international)	6.62 L (1.75 U.S. gallons)
Radiator Cap Pressure		1 BAR (14 psi)
Engine Oil (with filter)	Conventional oils - select the oil viscosity based on the ambient temperature where the engine is being operated. See SAE viscosity chart. Full Synthetic Oil 0W-40. Do not mix oil types. .	5.87 L (6.2 U.S. quarts)
API-CK-4 preferred, API-CJ-4 SM acceptable	<p>The chart shows the following temperature ranges for each oil grade:</p> <ul style="list-style-type: none"> <li>SAE 10W: -22°F to 32°F (-30°C to 0°C)</li> <li>SAE 20W: -4°F to 32°F (-20°C to 0°C)</li> <li>SAE 5W-30: -22°F to 50°F (-30°C to 10°C)</li> <li>SAE 10W-30: -4°F to 50°F (-20°C to 10°C)</li> <li>SAE 15W-40: -4°F to 68°F (-20°C to 20°C)</li> <li>SAE 20: 32°F to 68°F (0°C to 20°C)</li> <li>SAE 30: 50°F to 86°F (10°C to 30°C)</li> <li>SAE 40: 68°F to 104°F (20°C to 40°C)</li> </ul>	

**Fig. 5 - Fluids/Lubricants Type and Capacities**

1. Ultra-Low Sulfur Diesel (ULSD) fuel lubricity must have a maximum scar diameter of 0.45 mm, as measured by ASTM D6079 or ISO 12156-1, or a minimum of 3100 grams as measured by ASTM D6078. Contact your fuel supplier for details. Specification 1-D S15 or 2-D S15, ASTM D975.

# Specifications

## Dimensions

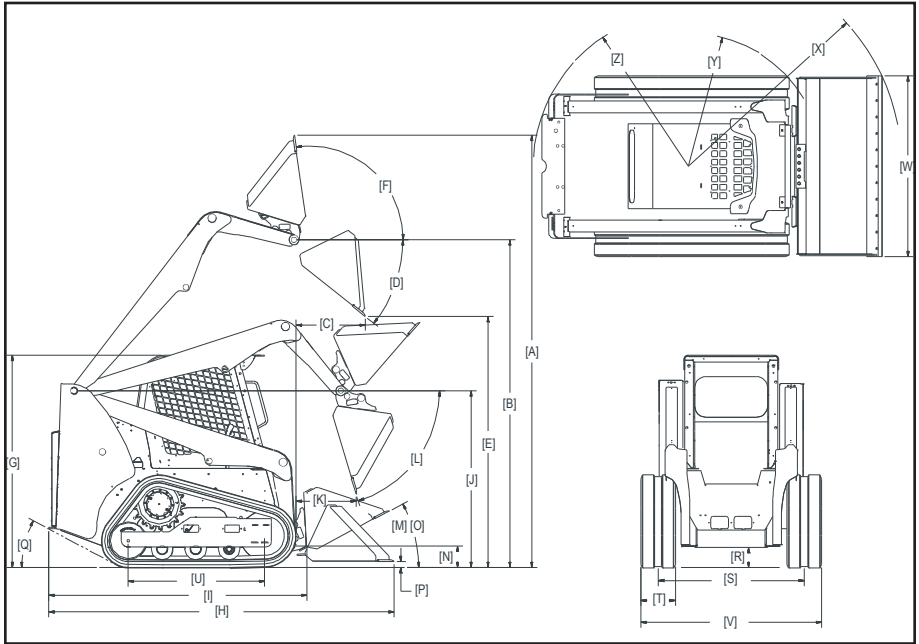

**Fig. 6 - Dimensions**

<b>A</b>	Overall Operation Height – Fully Raised	3650 mm (143.7 in.)
<b>B</b>	Height to Hinge Pin – Fully Raised	2769 mm (109.0 in.)
<b>C</b>	Reach - Fully Raised	673.1 mm (26.5 in.)
<b>D</b>	Dump Angle - Fully Raised	38°
<b>E</b>	Dump Height - Fully Raised	2134 mm (84.0 in.)
<b>F</b>	Maximum Rollback Angle - Fully Raised	102°
<b>G</b>	Overall Height – Top of ROPS	1816 mm (71.5 in.)
<b>H</b>	Overall Length with Bucket (w/o Counterweight)	2985 mm (117.5 in.)
<b>I</b>	Overall Length without Bucket (w/o Counterweight)	2258 mm (88.9 in.)
<b>J</b>	Specified Height	1466 mm (57.7 in.)
<b>K</b>	Reach at Specified Height	991 mm (39.0 in.)
<b>L</b>	Dump Angle at Specified Height	72°
<b>M</b>	Maximum Rollback Angle at Ground	32°
<b>N</b>	Carry Position	127 mm (5.0 in.)
<b>O</b>	Maximum Rollback Angle at Carry Position	32°
<b>P</b>	Digging Position	0 mm (0 in.)
<b>Q</b>	Departure Angle (w/o Counterweight)	35°

## Specifications

<b>R</b>	Ground Clearance	191 mm (7.5 in.)
<b>S</b>	Track Gauge	1039 mm (40.9 in.)
<b>T</b>	Track Shoe Width	249 mm (9.8 in.)
<b>U</b>	Crawler Base	1283 mm (50.5 in.)
<b>V</b>	Overall Width (w/o Bucket)	1290 mm (50.8 in.)
<b>W</b>	Bucket Width	1372 mm (54.0 in.)
<b>X</b>	Clearance Radius – Front (with Bucket)	1854 mm (73.0 in.)
<b>Y</b>	Clearance Radius – Front (w/o Bucket)	1168 mm (46.0 in.)
<b>Z</b>	Clearance Radius – Rear (w/o Counterweight)	1290 mm (50.8 in.)

**Table 3 - Dimensions (9.8 ft<sup>3</sup> (0.28 m<sup>3</sup>) Bucket)**

### Payloads/Capacities

**NOTE:** *Pallet fork load center is the distance from the front face of the forks to the center of mass of the load.*

<b>Dirt / Construction Buckets</b>	<b>Weight</b>	<b>Rated Operating Capacity</b>
1372 mm/0.28 m <sup>3</sup> (54.00 in./9.8 ft <sup>3</sup> )	129 kg (285 lbs.)	476 kg (1050 lbs.)
1524 mm/0.31 m <sup>3</sup> (60.00 in./11.0 ft <sup>3</sup> )	138 kg (305 lbs.)	467 kg (1030 lbs.)
1549 mm/0.33 m <sup>3</sup> (61.00 in./11.6 ft <sup>3</sup> )	141 kg (310 lbs.)	465 kg (1026 lbs.)
<b>Pallet Forks</b>	<b>Weight</b>	<b>Rated Operating Capacity</b>
406.4 mm (16.00 in.) Forks with Backrest Rating per EN474-3	213 kg (470 lbs.)	319 kg (704 lbs.)
508 mm (20.00 in.) Forks with Backrest Rating per EN474-3	213 kg (470 lbs.)	229 kg (660 lbs.)
609.6 mm (24.00 in.) Forks with Backrest Rating per SAE J1197	213 kg (470 lbs.)	281 kg (620 lbs.)

1. Measured on firm and level ground. Equipped with full fluids and 75 kg (165 lbs.) operator.

**Table 4 - Payloads and Capacities**

# Specifications

## Weights (shown with standard options)

	1050RT
Operating Mass <sup>1</sup>	2141 kg (4720 lbs.)
Maximum Permissible Weight <sup>3</sup>	2617 kg (5770 lbs.)
Shipping Weight <sup>2</sup>	1928 kg (4250 lbs.)

1. Equipped with standard bucket, driver and full fluids.
2. Without operator and driver; 10% fuel.
3. Operating mass and a full bucket.

**Table 5 - Weights**

## Coolant Compound Table

Outside Temperature Up to °F (°C)	Water	Anti-corrosion agent		Antifreeze
	% by volume	in <sup>3</sup> /gal (cm <sup>3</sup> /L)	% by Volume	% by volume
39 (4)	99	2.6 (10)	1	-
14 (- 10)	79			20
-4 (- 20)	65			34
-13 (- 25)	59			40
-22 (- 30)	55			45
-44 (-42)	50			50

**Table 6 - Coolant Compound Table**

## Tracks

	1050RT
Tractive Effort (Theoretical)	1996 kg (4400 lbs)
Parking Brake	Spring Applied/Hydraulically Released
Grade-ability	30°
Track Type/Track Rollers/Roller Type	Rubber/3/Steel
Ground Pressure	.33 Bar (4.8 psi)

**Table 7 - Tracks**

## Engine

	1050RT
Engine Make	Yanmar
Engine Model (DPF) / (Non-DPF)	3TNV88C-KMSV (DPF) / 3TNV88-BKMS (Non-DPF)
Design	In-line 3 cylinder, 3-stroke diesel, naturally aspirated

# Specifications

	1050RT
Exhaust Emission Compliance (DPF) / Non-DPF)	EPA Tier 4, EU Stage 5 (DPF) / EPA Interim Tier 4, Stage 3A (Non-DPF)
Applied Regulation	EPA Tier 4 / EU Stage 5
Displacement	1,64 L (100 in <sup>3</sup> )
Bore and Stroke	88 x 90 mm
Compression Ratio	19.1:1
Gross Power (ISO/TR 14396 : SAE J 1995) (DPF) / (Non-DPF)	26 kW (35 hp) @ 2800 rpm (DPF) / 26 kW (35 hp) @ 2600 rpm (Non-DPF)
Peak Torque (DPF) / (Non-DPF)	109 Nm (80 ft.-lbs.) @ 1820 rpm (DPF) / 109 Nm (80 ft.-lbs.) @ 1200 rpm (Non-DPF)
Low/High Idle (No Load)	1500 / 2830 rpm
Rated - Full Load Speed	2800 rpm
Fuel Injection System	Direct Injection with common rail injection system
Fuel Delivery	High-pressure common rail
Fuel Filtering	In-line filter cartridge with water trap and replaceable element
Firing Order	1-3-2-1 (from flywheel end)
Normal Starting Aid	Individual cylinder glow plugs
Cold Starting Aid (Optional)	Engine block / Oil pan heater
Lubrication	Forced lubrication with trochoid pump
Crankcase Ventilation	Closed
Max. Inclined Angle (engine still supplied with oil)	30° in all directions
Cooling System	6,62 L (7 U.S. qts.)
Permissible Coolant Temperature	105° C (221° F)
Thermostat Rating	82° C (180° F)
Fan Ratio (Variable 0-100% w/ 25% step)	.92:1
Starter - Power	2.3 Kw 912-Volt-DC)
Alternator Voltage / Amperage (DPF) / (Non-DPF)	55 amperes (DPF) / 40 amperes (Non-DPF)

1. Operation above temperature range may result in overheating; operation below temperature range may result in hard-starting.

**Table 8 - Engine**



# Specifications

## Hydraulic System

	<b>1050RT</b>
Drive Speed	9.6 - 10.4 kph (6.0-6.5 mph)
<b>Hydrostatic Drive Motors</b>	
Maximum Working Pressure	420 Bar (6091 psi)

**Table 9 - Hydraulic System: Drive Hydraulics**

	<b>1050RT</b>
Main Relief Valve Pressure	195 bar (2828 psi)
System Relief Pressure @ Quick Couplers	189.6 Bar (2750 psi)
Total Flow @ 2500 rpm (Theoretical)	55 L/Min (14.5 Gpm)

**Table 10 - Hydraulic System: Work Hydraulics**

## Sound Power/Pressure Levels

	<b>1050RT</b>
Noise Level/Environmental Level (EU Dir. 2000/14/EC) <sup>1</sup>	103 db(A)
Operator Ear (EU Dir. 2006/42/EC) <sup>2</sup>	85.8 dB(A)

1. Declared sound power level per ISO 6395:2008 with closed cab @ 70% max. engine cooling fan.
2. Declared sound pressure level per ISO 6396:2008 with closed cab @ 70% max. engine cooling fan.

**Table 11 - Sound Power/Pressure Levels**

## Vibration Levels

	1050RT
<b>Whole-Body Vibration (ISO 2631-1)</b>	
Mechanical Suspension Seat	0.98 m/s <sup>2</sup>
Mechanical Suspension Seat - Joystick Only	1.06 m/s <sup>2</sup>
<b>Hand-Arm Vibration (ISO 5349-1)</b>	
T-Bar	3.92 m/s <sup>2</sup>
Hand/Foot	4.31 m/s <sup>2</sup>
Joystick	4.55 m/s <sup>2</sup>

**Table 12 - Vibration Levels**

# Specifications

---

## Standard and Optional Features

### **Standard Features**

- ▶ Control Types: T-Bar and Hand/Foot
- ▶ Fuel Gauge
- ▶ Horn
- ▶ Deluxe Sound Package
- ▶ Battery Disconnect Switch
- ▶ All-Tach™ Attachment System
- ▶ Warning Lamps and Buzzer - Engine and Hydraulic Oil Temperature
- ▶ Battery Charge Indicator Lamp
- ▶ Low Oil Pressure Light and Buzzer
- ▶ Seatbelt Indicator Lamp and Buzzer
- ▶ Coolant Temperature Gauge
- ▶ Hour meter
- ▶ Manual-Control Hydrostatic Drive
- ▶ ROPS/FOPS-Level II - Approved Overhead Guard
- ▶ Independent Hydraulic Reservoir and Hydraulic Oil Cooler
- ▶ Foot and Hand Throttle
- ▶ Operator Restraint Bar with Armrests
- ▶ Audible Back-Up Alarm
- ▶ Engine Intake Air Pre-Heater Starting Assist
- ▶ Adjustable Seatbelt
- ▶ Lift Arm Support Device
- ▶ Hydraloc™ System - Brakes and Interlock for Starter, Lift/Tilt Cylinders, Auxiliary Hydraulics and Track Drive
- ▶ Dual Front and Rear Work Lights
- ▶ Removable Belly Plate and Access Cover
- ▶ Dual-Element Air Cleaner with Visual Indicator
- ▶ Vandalism Lock Provisions

- ▶ Top and Rear Windows
- ▶ DPF Exhaust - Spark Arrestor Compliant
- ▶ Headliner and Acoustical Interior
- ▶ Adjustable Seat
- ▶ Front Auxiliary Hydraulics with 3/4-inch Flat-Faced Couplers
- ▶ Visual Hydraulic Filter Indicator
- ▶ Power Plug (12 V)

### **Optional Features**

- ▶ Control Type: Joystick
- ▶ Engine Block Heater
- ▶ Suspension Seat
- ▶ Cab Door with Wiper and Dome Light
- ▶ Sliding Side Windows
- ▶ Heater/Defroster
- ▶ 3-inch Wide Seatbelt - When Required by Law
- ▶ Rear View Mirror
- ▶ Engine Auto-Shutdown System
- ▶ Interior Dome Light
- ▶ Centrifugal Pre-Cleaner
- ▶ Strobe Light
- ▶ Impact-Resistant Door
- ▶ Four-Point Lift Kit
- ▶ Rear Counterweight
- ▶ Bucket Bolt-On Cutting Edge
- ▶ Self-Leveling Lift Action
- ▶ Ride Control

## Common Materials and Densities

Material	Density	
	kg/m <sup>3</sup>	lbs./ft <sup>3</sup>
Ashes	560-800	35-50
Brick-common	1792	112
Cement	1760	110
Charcoal	368	23
Clay, wet-dry	1280-1600	80-100
Coal	848-1008	53-63
Concrete	1840	115
Cinders	800	50
Coal-anthracite	1504	94
Coke	480	30
Earth-dry loam	1121-1442	70-90
Earth-wet loam	1281-1602	80-100
Granite	1488-1776	93-111
Gravel-dry	1602	100
Gravel-wet	1922	120
Gypsum-crushed	1840	115
Iron ore	2320	145
Lime	960	60
Lime stone	1440	90
Manure-liquid	1040	65
Manure-solid	720	45
Peat-solid	752	47
Phosphate-granular	1440	90
Potash	1088	68
Quartz-granular	1760	110
Salt-dry	1602	100
Salt-rock-solid	2160	135
Sand-dry	1728	108
Sand-wet	2000	125
Sand-foundry	1520	95
Shale-crushed	1440	90
Slag-crushed	1120	70
Snow	240-800	15-50
Taconite	1712	107

# Specifications

## Direct and/or Indirect Visibility

Tested in accordance with ISO 5006: 2017.

The machine has been subjected to a static visibility assessment with the lift structure in a carry position or 200 mm (7-7/8 in.) above the ground. The test simulates operator visibility from the operator’s position:

- The line of sight between the operator’s eye position and a point on the ground at a 12 m (472 in.) radius.
- On a rectangular boundary 1 m (39 in.) from the machine, 12 m (47 in.) above the ground.
- Masking was recorded as shown (Fig. 6), and is within the allowable limits in accordance with ISO 5006: 2017.
- The standard/test does not account for head movement or rotation, which can improve visibility and mitigate masking.

**This diagram indicates the blind spot zone on the visibility test circle (radius = 12 m [47 ft.]) and the 1 m (39 in.) rectangular zone around the machine.**

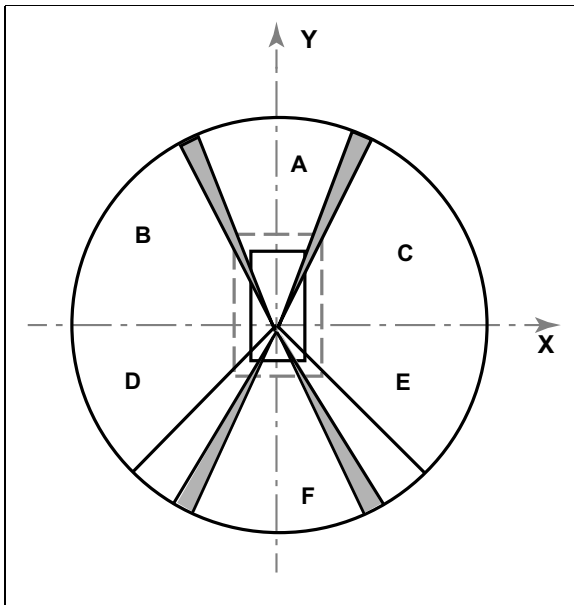

**Fig. 6 – Visibility Performance**

# Chapter 5

## INDICATORS AND CONTROLS

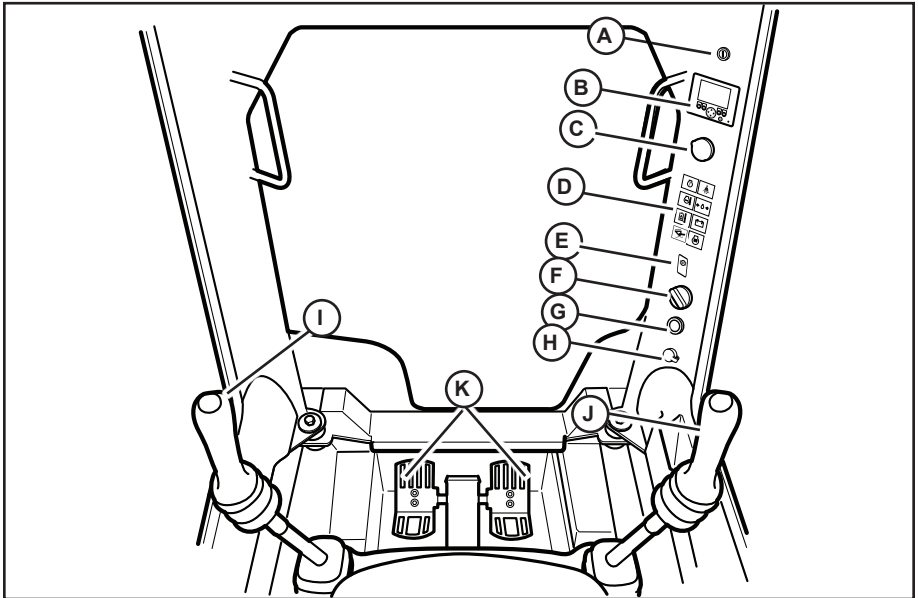

**Fig. 7 - Operator Controls (Hand/Foot Control Option Shown)**

Ref	Item	Description
A	Ignition Key switch	Controls ignition, engine start and run.
B	Information Center Electronic Display	Displays operation status messages and configures performance options.
C	Fuel Gauge	Displays amount of fuel in the fuel tank.
D	Control Illumination Panel	Activated functions illuminate when used.
E	Parking Brake Switch	Controls the parking brake.
F	Throttle Control	Primary engine speed control (H/F models).
G	Light Switch	Controls all the lights on the loader.
H	Accessory Outlet	12-volt DC power outlet.
I	Left Control Handle	Controls travel drive operation and horn.
J	Right Control Handle	Controls travel drive operation and auxiliary hydraulics (H/F models). Controls lift/tilt and lift arm float (JS models).
K	Foot Controls	Controls attachment lift/tilt operation and lift arm float (H/F models)..

# Indicators and Controls

## Display(s)

### Information Center Electronic Display

The information center electronic display is located on the right door pillar. It provides the following functionality:

- Displays operational status such as engine RPM, coolant temperature and service hours.
- Displays error fault codes and input/output diagnostic data.
- Configures displays settings.

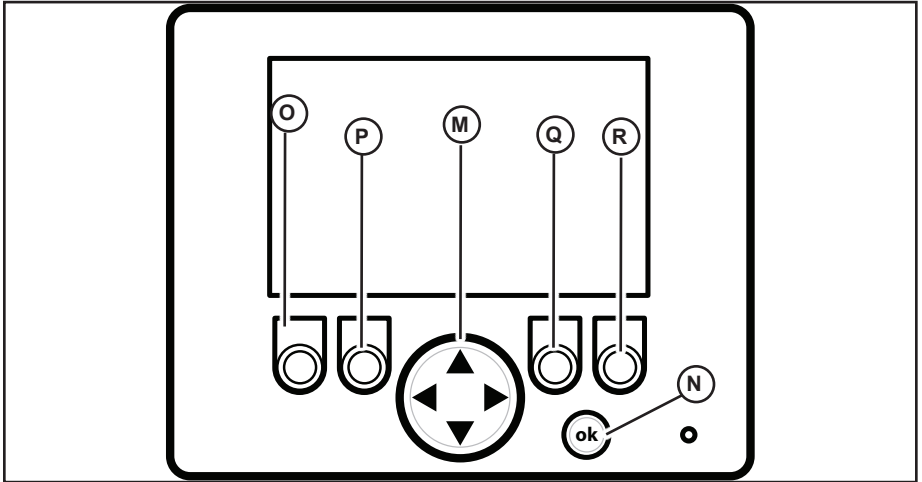





Fig. 8 - Information Center Electronic Display

M. Navigation Rocker Button – Used for general screen navigation and other various functions, depending upon screen and context.



P. Increase Brightness/Return Button – Used for different functions depending upon screen and context:

- Used to increase display brightness. Corresponds to the  symbol on the display screen.
- Used to return to previous screen. Corresponds to the  symbol on the display screen.

N. OK Button – Used for various functions, depending upon screen and context.

Q. Decrease Brightness Button – Used to decrease display brightness. Corresponds to the  symbol on the display screen.

O. Regen/Return Button – Used for different functions depending upon screen and context:

- Switches to the Regen display mode if the  symbol is displayed on the screen. Also initiates DPF regeneration if all appropriate conditions are met.
- Used to return to previous screen. Corresponds to the  symbol on the display screen.

R. Regen Inhibit Button – Press for 5 seconds to inhibit DPF reset regeneration. Displays the  symbol.









## WARNING

If the LCD is broken, care must be taken with any leaking fluid. If LCD fluid gets onto your skin, wipe with a cloth and wash the area with mild soap and water. If LCD fluid gets into your eyes, thoroughly rinse your eyes with clean water for several minutes and seek medical assistance. If LCD fluid is swallowed, rinse your mouth thoroughly with clean water, then drink a substantial volume of water and induce vomiting. Then seek medical assistance.

### Information Center Electronic Display Symbols







The following table describes symbols used in the information center electronic display.

**NOTE:** Values may not display for all parameters, depending upon installed options and equipment.

Symbol	Description	Symbol	Description
	Engine crankshaft revolutions per minute.		Real-time fuel consumption rate. Displayed in gallons/hour (SAE) or liters/hour (METRIC).
	Accumulated operation time. Time is displayed in hours, and accumulates when the engine is running.		Display brightness increase. Press button (P, Fig. 8) when this symbol is displayed to increase screen brightness.
	Battery charging circuit voltage.		Display brightness decrease. Press button (Q, Fig. 8) when this symbol is displayed to decrease screen brightness.

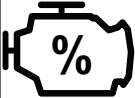

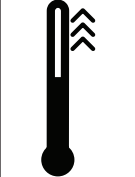
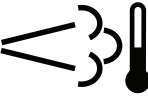
# Indicators and Controls



	<p>Coolant temperature.</p>		<p>Diesel Particulate Filter (DPF) regeneration. See “Diesel Particulate Filter (DPF) Regeneration Procedures” on page 90.</p> <p>Strike-through line through the symbol is displayed in red when DPF regeneration is inhibited.</p>
	<p>Percentage of engine power based on load.</p>		<p>Diesel Particulate Filter (DPF) regeneration inhibit (DPF Models). See “Diesel Particulate Filter (DPF) Regeneration Procedures” on page 90.</p>
	<p>Ambient engine compartment temperature.</p>		<p>Diesel Particulate Filter (DPF) regeneration in-progress (elevated temperature). See “Diesel Particulate Filter (DPF) Regeneration Procedures” on page 90.</p>
	<p>Aftertreatment Error Engine Emission System Failure. Indicates an error or fault with emission critical components.</p> <p>NOTE: Engine derate will occur if error/fault not corrected.</p>		<p>Engine Malfunction - Indicates the engine ECU has detected a malfunction of the engine.</p>

## Information Center Electronic Display Screens

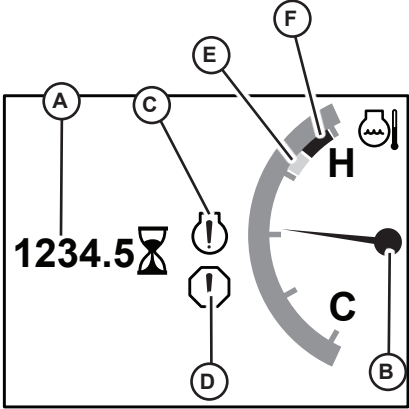
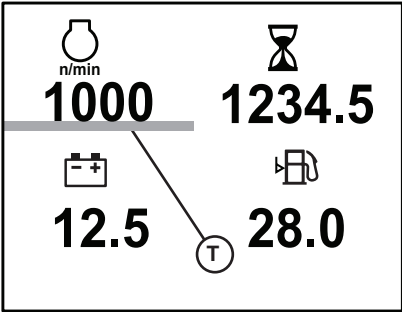
**NOTE:** Values may not display for all parameters, depending upon installed options and equipment.

Display Mode	Description
	<p><b>Dual Gauge Display</b></p> <p>A. Accumulated operation time.</p> <p><b>NOTE:</b> Time is displayed in hours, and accumulates when the engine is running.</p> <p>b. Engine coolant temperature.</p> <p>c. Amber error condition warning. Causes DM1/DM2 errors screen(s) to display. See page 53.</p> <p>d. Red critical error warning. Causes DM1/DM2 errors screen(s) to display. See page 53.</p> <p>e. Engine coolant temperature amber warning region. Indicates elevated coolant temperature.</p> <p>f. Engine coolant temperature red stop warning region. Indicates serious coolant overheating condition.</p> <p><b>NOTE:</b> Running the engine in an overheated condition can damage the engine.</p>
	<p><b>Quad Gauge Display</b></p> <p>Displays four different status parameters simultaneously. To change the displayed parameters, press and hold the ok button (N, Fig. 8) until orange bar (T) displays. Press the left/right side of navigation rocker button (M, Fig. 8) to select the parameter and press the top/bottom of navigation rocker button to change the selected parameter. Press the ok button again to dismiss orange bar (T).</p>

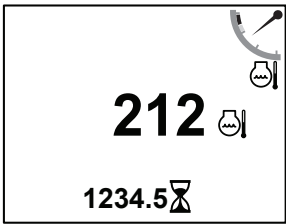
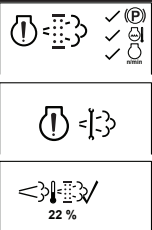
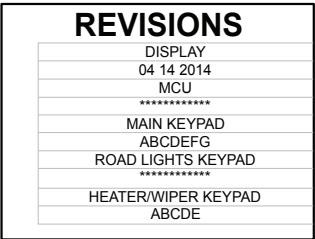
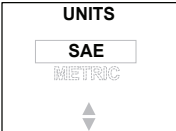
# Indicators and Controls

<b>Table 14 - Status, Maintenance and Error Code Screens</b>	
<b>Display Mode</b>	<b>Description</b>
	<p><b>Single Gauge Display</b></p> <p>Displays single real time operating parameters. Switch between parameters using the navigation button (M, Fig. 8). Used for various functions, depending upon screen and context.</p>
	<p><b>Regeneration Screens</b></p> <p>These screens are associated with Diesel Particulate Filter (DPF) regeneration procedures and maintenance. See “Diesel Particulate Filter (DPF) Regeneration Procedures” on page 90.</p>
Secondary Screens	
All Secondary Screens	<p>Secondary screens are accessed by holding down the ok button (N, Fig. 8) for 10 seconds while the Dual Gauge Display screen is displayed. Press the left/right side of navigation rocker button (M, Fig. 8) to switch between secondary screens.</p>
	<p><b>Revision Screen</b></p> <p>Displays information center electronic display software information.</p>
	<p><b>Units Screen</b></p> <p>Press the top/bottom of navigation rocker button (M, Fig. 8) to switch between SAE or metric units for values displayed in screens.</p>
	<p><b>Language Screen</b></p> <p>The press the top/bottom of navigation rocker button (M, Fig. 8) to switch between English or Spanish language for values displayed in screens.</p>

<b>Table 14 - Status, Maintenance and Error Code Screens</b>				
<b>Display Mode</b>	<b>Description</b>			
<div style="border: 1px solid black; padding: 5px; margin-bottom: 5px;"> <p style="text-align: center;"><b>DM1</b></p> <p style="font-size: small;">0 of 0</p> <table border="1" style="width: 100%; border-collapse: collapse;"> <tr> <td style="text-align: center; padding: 5px;"><b>SPN: 0</b></td> </tr> <tr> <td style="text-align: center; padding: 5px;"><b>FMI: 0</b></td> </tr> <tr> <td style="text-align: center; padding: 5px;"><b>OCI: 0</b></td> </tr> </table> <p style="text-align: center;">▼ ▲</p> </div>	<b>SPN: 0</b>	<b>FMI: 0</b>	<b>OCI: 0</b>	<p><b>DM1 Screen</b></p> <p>Displays engine, drive system, control, and safety system error code message information. Number of available messages is displayed at the top left of the screen (T). Use buttons (P and Q, Fig. 8) to scroll through the messages. See "Error Codes" on page 139 for specific error code details.</p>
<b>SPN: 0</b>				
<b>FMI: 0</b>				
<b>OCI: 0</b>				
<div style="border: 1px solid black; padding: 5px; margin-bottom: 5px;"> <p style="text-align: center;"><b>DM2</b></p> <p style="font-size: small;">0 of 0</p> <table border="1" style="width: 100%; border-collapse: collapse;"> <tr> <td style="text-align: center; padding: 5px;"><b>SPN: 0</b></td> </tr> <tr> <td style="text-align: center; padding: 5px;"><b>FMI: 0</b></td> </tr> <tr> <td style="text-align: center; padding: 5px;"><b>OCI: 0</b></td> </tr> </table> <p style="text-align: center;">▼ ▲</p> </div>	<b>SPN: 0</b>	<b>FMI: 0</b>	<b>OCI: 0</b>	<p><b>DM2 Screen</b></p> <p>Continuation of error code message display along with DM1 Screen. Number of available messages is displayed at the top left of the screen (T). Use buttons (P and Q, Figure 17) to scroll through the messages. See "Error Codes" on page 139 for specific error code details.</p>
<b>SPN: 0</b>				
<b>FMI: 0</b>				
<b>OCI: 0</b>				

# Indicators and Controls

## Switch Panel

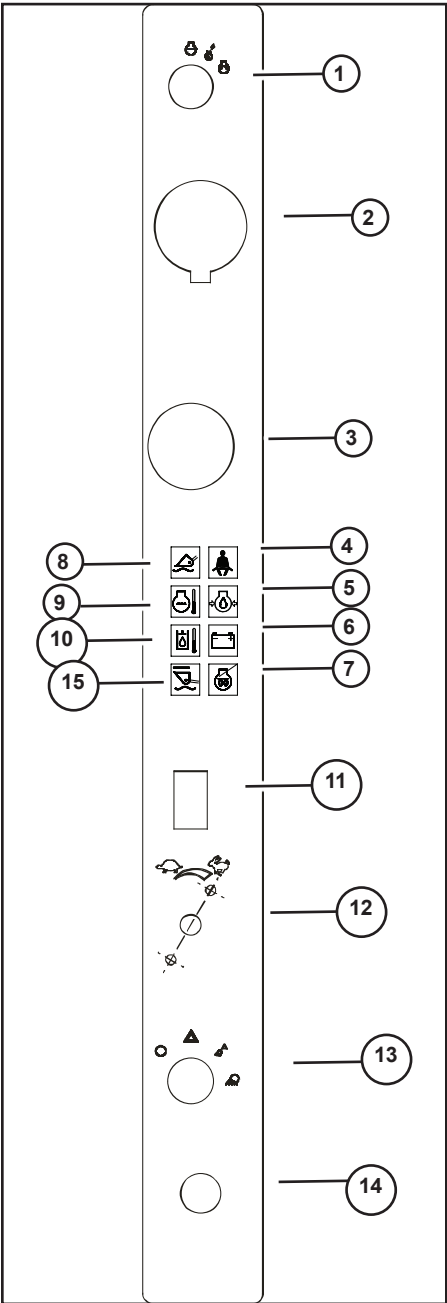

Fig. 9 - Instrument Panel

## ***Instrument Panel***

The instrument panel contains the following switches and indicators. Symbols on the panel represent various functions and conditions, and are visible only when indicator lamps are on

1. Key switch – In a clockwise rotation, these positions are:

OFF Position – With the key vertical, power from the battery is disconnected from the controls and instrument panel electrical circuits. This is the only position from which the key can be inserted or removed.

ON (or RUN) Position – With the key turned one position clockwise from vertical, power from the battery is supplied to all control and instrument panel circuits.

START Position – With the key turned fully clockwise, the electric starter engages, to start the engine. Release the key to RUN position after the engine starts.

**NOTE:** *The engine cannot be started unless the operator is sitting in the seat and the restraint bar is lowered.*

2. Information Center Electronic Display – See page 48.
3. Fuel Level Gauge – Displays the amount of fuel in the tank.
4. Fasten Seatbelt – A momentary visual (and audible) indicator to remind the operator to fasten the seatbelt.
5. Engine Oil Pressure – Lights if the engine oil pressure drops too low, warning the operator to immediately stop the engine and determine the cause for the pressure drop. During normal operation, this indicator should be OFF.
6. Battery – Lights if the charging voltage is too high or too low. During normal operation, this indicator should be OFF.
7. Preheat Indicator Lamp – Lights when the (automatic) preheat is active. During normal operation this indicator should be OFF.
8. Float Control Lamp – Lights when the float control is active. During normal operation this indicator should be OFF.
9. Engine Coolant Temperature – Lights if the engine coolant becomes too hot, warning the operator to stop the engine. Allow the engine to cool, determine the cause for the high temperature and correct the problem before restarting the engine. During normal operation, this indicator should be OFF.
10. Hydraulic Oil Temperature – Lights if the hydraulic oil becomes too hot, warning the operator to stop engine. Allow the hydraulic system to cool and determine the cause of the high temperature. During normal operation, this indicator should be OFF.
11. Parking Brake Switch – Used to manually apply the parking brake. Lights when the parking brake is applied.
12. Engine Speed Control – Controls the engine speed. Move the control clockwise to increase and counter-clockwise to decrease the engine speed.

## Indicators and Controls

13. Light Switch – Controls all the lights on the loader. Symbols denote the four positions of the light switch. In a clockwise direction these are:

- OFF
- Tail Lights ON
- Front Work Lights with Tail Lights ON
- Both Front and Rear Work Lights

For the lights to function, the key switch must be in the RUN position.

14. Accessory Outlet – 12-volt DC power outlet.
15. Hydraglide™ Ride Control System (Joysticks option only) – Lights when the ride control system is activated. During normal operation this indicator should be OFF.

### Operator's Seat

The operator's seat has adjustments for:

- Forward and back horizontal seat position.



**Never adjust the seat when the machine is in operation. Adjust the seat only when the machine is stopped and the parking brake is applied.**

**All controls must be within easy reach. The operator must be able to move the throttle pedal and the control handles through the complete range of motion.**

**After adjustments, make sure levers for the seat are fully engaged before using the machine.**

### Throttle Controls

Engine throttle controls engine speed, which determines available power.

Engine throttle is controlled with both a knob (I, Fig. 10) and a pedal (J, Fig. 11).

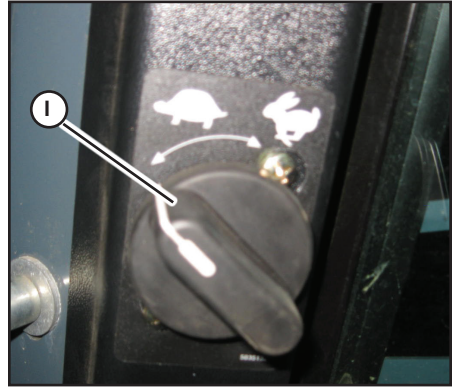

Fig. 10 - Throttle Knob

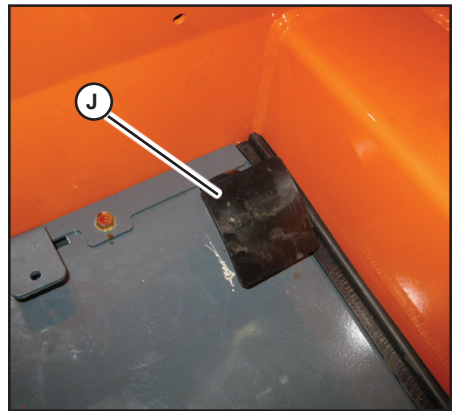

Fig. 11 - Pedal

The throttle knob (I) is the primary throttle control. Generally, the throttle is set with the knob to the desired position. The pedal can then be used to increase engine speed whenever additional power is required. When the pedal is released, the engine returns to the speed set by the throttle knob.

**IMPORTANT:** Tier 4 engines are designed to be run hot, at high throttle settings under heavy loads. Extended periods of low-temperature Tier 4 engine operation rapidly increases DPF soot levels, requiring more frequent DPF regeneration operations.

## Travel Controls

Forward, reverse, and turning functions are performed using the control handles.

## Lift Arm Float



**Make sure the bucket is lowered to the ground before activating the lift arm float. Activating float with an attachment raised will cause it to fall, which can cause severe injury or death.**

## T-Bar Controls

To place the lift arm into the detent (“float”) position, push the right T-Bar all the way forward into the detent. This position allows the lowered lift arm to “float” while traveling over changing ground conditions.

## Hand/Foot Controls

To place the lift arm in the detent (“float”) position, use your toes to push the left pedal all the way down into the detent. This position allows the lowered lift arm to “float” while traveling over changing ground conditions.

## Joystick Controls

To place the lift arm in the detent (“float”) position, press the float button on the right control handle. Press float button for 5 seconds to activate continuous float. This position allows the lowered lift arm to “float” while traveling over changing ground conditions. Press button again to deactivate continuous float.

## Emergency Lift Arm Lower



**Never use the float mode with the attachment raised, because this will cause the lift arm to lower very rapidly. The float mode can be used where the engine has stopped, is unable to be started, and lowering the lift arm is necessary to allow the operator to exit the loader.**

## Parking Brake/ Hydraulics Transport Lockout

The parking brake is automatically applied whenever:

1. The engine is stopped.
2. The restraint bar is in the raised position.
3. The operator leaves the seat.
4. The cab swing-out door (if equipped) is opened.

**NOTE:** *The above conditions also disable the hydraulic controls, with the exception of standard auxiliary hydraulics continuous flow.*

The parking brake can alternately be applied by pressing parking brake switch on the instrument panel until the indicator lights in the switch and the parking brake icon on the indicator panel are lit.

Before starting the engine, sit in the operator’s seat and lower the restraint bar. Close the swing-out door (if equipped).

**IMPORTANT:** *The engine cannot be started if the restraint bar is in the raised position, the cab swing-out door is open (if equipped), or the operator is not in the seat.*



# Indicators and Controls

## Horn

On hand/foot loaders, pressing the right button on the left control handle sounds the horn. On T-bar loaders, pressing the bottom button on the left control handle sounds the horn.

## Cab Heat (Option)

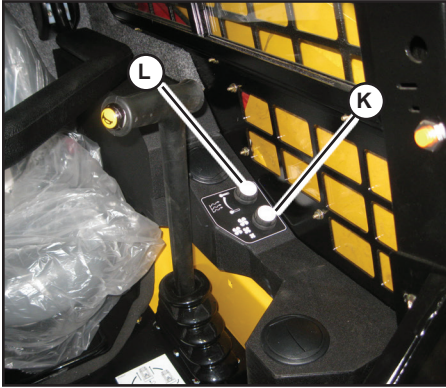

Fig. 12 - Heater Controls

Loaders with the optional heater have two control knobs on top of the heater unit for controlling fan speed and heater temperature.

1. Fan Speed Control Knob (K, Fig. 12): Controls the fan speed and turns the heater system on or off.
2. Temperature Control (L, Fig. 12): The rotary knob regulates the temperature of the heated air. Rotate clockwise to increase the temperature; counterclockwise to decrease the temperature.

## Windshield Wiper/Washer

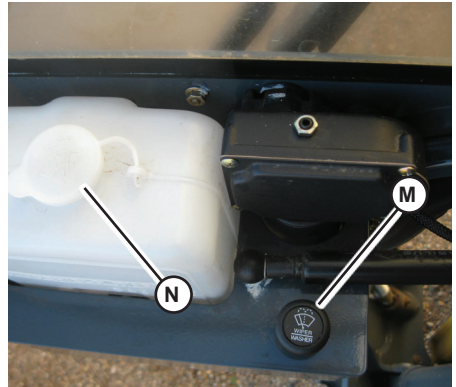

Fig. 13 - Windshield Wiper Control and Reservoir

Turn the wiper control (M, Fig. 13) to regulate the speed of the wiper blade. Press the wiper control to dispense wiper fluid to the windshield.

The windshield wiper reservoir (N, Fig. 13) is located inside the door.

**IMPORTANT:** Fill the windshield washer fluid reservoir with a commercial windshield washer fluid or clean tap water only. Add a cleaning agent to the water if required. Add antifreeze to the water in cold weather.

## Beacon (Option)

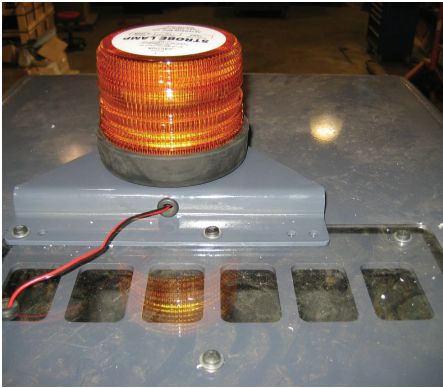

Fig. 14 - Beacon Light

The beacon is controlled by the light switch control on the instrument panel, if so equipped.

## Battery Disconnect Switch

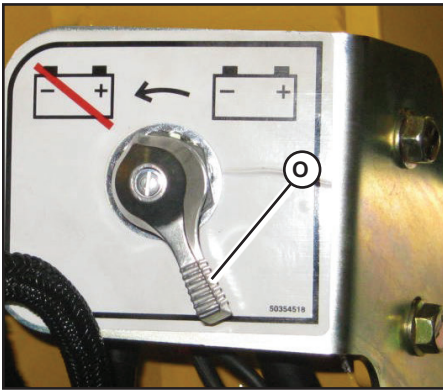

Fig. 15 - Battery Disconnect Switch

An electrical battery disconnect switch (O, Fig. 15) is located inside the engine compartment on the left side and forward of the fuse panel. Turn the switch to the OFF position to disconnect the battery from the electrical system.

## Hydraglide™ Ride Control System (Option)

### **WARNING**

When Hydraglide™ ride control is activated, the lift arm may drop slightly without a load, or several inches with a heavy load. Do not use Hydraglide™ when using pallet forks.

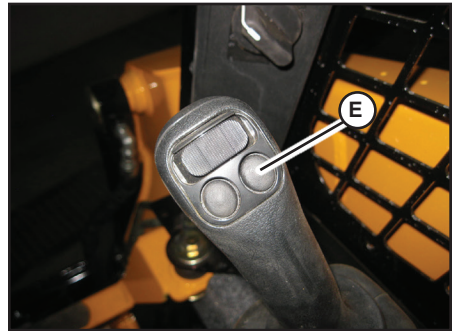

Fig. 16 - Hydraglide™ Control Button

Hydraglide™ cushions lift arm loads during transport. It provides a smoother ride over uneven surfaces.

Press button (E, Fig. 16) to activate Hydraglide™ ride control. Press button (E) again to deactivate.

When Hydraglide™ is activated, the Hydraglide™ indicator on the control pad is lit.

**NOTE:** *Hydraglide™ is automatically deactivated when the machine is shut off.*

**IMPORTANT:** *Do not use Hydraglide™ when digging. Precise control of the digging operation is difficult when Hydraglide™ is activated.*

Activate Hydraglide™ when driving on public roads, for lighter loads, and for light off-road transport. Deactivate Hydraglide™ when working with heavy loads, such as when picking up excavated material.



# Chapter 6

## OPERATION

**WARNING**

**Read and understand this entire manual. Follow warnings and instructions for operation and maintenance. Failure to follow instructions can result in injury or death.**

**Read and understand all safety decals before operating the machine. DO NOT operate the machine unless all factory-installed guards and shields are in place.**

**Be sure you are familiar with all safety devices and controls before operating the machine.**

**Know how to stop the machine before starting.**

**Use only Manitou-approved accessories or referral attachments. Manitou Group cannot be responsible for safety if the machine is used with non-approved accessories or attachments.**

**Check for correct function after adjustments or maintenance.**

### Operational Checks/Pre-start Inspection

Complete these inspections before starting the engine and using the machine. Repair any problems before using the machine.

<i>Inspect</i>	<i>Refer To:</i>
Fuel tank filled?	"Fuel System Maintenance" on page 112
Engine oil level correct?	"Swing-out cab door closed (if equipped)?" on page 61
Hydraulic system oil level correct?	"Checking Hydraulic Oil Level" on page 114

<i>Inspect</i>	<i>Refer To:</i>
Engine coolant level correct?	"Checking Coolant Level" on page 116
Window washer reservoir filled?	" " on page 122
Grease fittings properly lubricated?	"Operational Checks/Pre-start Inspection" on page 61
Belt tension / condition good / tension adjustment correct?	"Alternator/Fan Belt" on page 117
Track condition good?	"Track Maintenance" on page 119
Lights, signals, indicators, and horn operating properly?	"Work Lights Button" on page 61
Windows, lights, and steps clean?	
Attachment securely fastened to hitch?	"Connecting/Disconnecting Attachments" on page 79
Overall machine condition (including attachments) for bends, cracks, broken or missing parts, etc.	
Approved warning triangle, hazard warning light and first aid kit in the machine?	If required by local regulations.
Swing-out cab door closed (if equipped)?	"Before Operation" on page 62
Seat position correctly adjusted?	"Operator's Seat/Armrest" on page 61
Armrest consoles correctly adjusted?	
Seat belt fastened?	"Seat Belt" on page 62
Parking brake applied?	"Parking Brake" on page 63

# OPERATION

## Before Operation

### *Cab Entry and Exit*



Fig. 17 - Cab Entry / Exit Handles / Step

## **WARNING**

Always perform the “Mandatory Safety Shutdown Procedure” on page 16 before exiting the machine.

When entering/exiting machines equipped with a door, open the door fully to the locked position and check that it does not move.

Use only step (B, Fig. 17) and hand-holds (A) on the machine when entering/exiting the cab. Keep the steps and the handles clean to ensure a secure hold at all times. Never use the control joysticks as hand-holds. Remove dirt (oil, grease, earth, snow, ice, etc.) from handles (A), step (B) and your shoes before entering the cab.

Always face the machine when entering/exiting.

Do not jump on or off the machine. Never climb onto or exit a moving machine.

## Seat Belt

## **WARNING**

**ALWAYS** fasten the seat belt securely and properly. Never operate the machine without the seat belt fastened around the operator.

Keep the seat belt clean; dirt can impair seat belt operation. Check seat belt condition regularly and have damaged or worn belts immediately repaired by an authorized dealer.

After an accident, the seat belt strap is stretched and must be replaced with a new strap installed by an authorized dealer.

Make sure the seat belt is not twisted when it is fastened, and that it is fastened over the hips and not the stomach.

Fasten the seat belt tightly and securely. Remove hard, edged or fragile objects from your pockets or clothes that might lie between the seat belt and your body.

### ***Fastening / Unfastening the Seat Belt***

Fasten the seat belt around your hips and waist and insert tongue (A, Fig. 18) into clasp (B) until it clicks securely in place. Slack in the seat belt should automatically retract into seat belt spool (C).

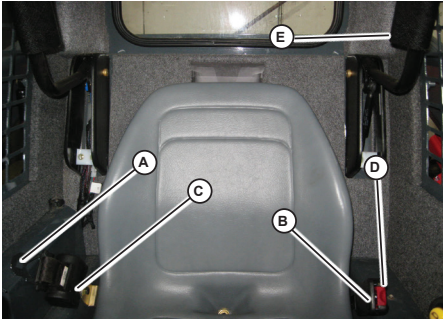

Fig. 18 - Seat Belt

## WARNING

**If the seat belt spool does not retract slack in the seat belt, have it serviced immediately. Do not operate the machine until the seat belt is repaired.**

Unfasten the seat belt by pressing button (D).

## Parking Brake

The parking brake is automatically applied whenever:

1. The engine is stopped.
2. The restraint bar is in the raised position (E, Fig. 18).
3. The operator leaves the seat.
4. The cab swing-out door (if equipped) is opened.

**NOTE:** *The above conditions also disable the hydraulic controls, with the exception of standard auxiliary hydraulics continuous flow.*

The parking brake can alternately be applied by pressing parking brake button (F, Fig. 19) on the keypad until the indicator lights in the button and the parking brake icon on the indicator panel are lit.

Before starting the engine, sit in the operator's seat and lower the restraint bar. Close the swing-out door (if equipped).

**IMPORTANT:** *The engine cannot be started if the restraint bar is in the raised position, the cab swing-out door is open (if equipped), or the operator is not in the seat.*

## Disengage Parking Brake

1. Sit in the operator's seat and fasten the seat belt.
2. Close the cab swing-out door (if equipped).
3. Lower the restraint bar.
4. Start the engine.
5. Press and hold parking brake button (C, Fig. 33) on the left keypad for several seconds until the indicator lights in the button and the parking brake icon on the indicator panel go out.



Fig. 19 - Parking Brake Button

## Starting the Engine

**NOTE:** *The machine cannot be push- or tow-started. Attempting to push/tow start the machine may damage the drive system.*

1. Complete the "Operational Checks/Pre-start Inspection" on page 61.
2. Sit in the operator's seat and adjust the seat if required.



## OPERATION

### CAUTION

All controls must be within easy reach. The operator must be able to move the throttle pedal and the control joysticks through the complete range of motion.

3. Fasten the seat belt.

### WARNING

Always fasten the seat belt before operating the machine. Repair or replace any damaged seat belt and lock parts before operation.

4. Close the swing-out cab door, if equipped.

**IMPORTANT:** *The swing-out cab door must be closed before the engine can be started.*

5. Lower the restraint bar.

**IMPORTANT:** *The restraint bar must be lowered before the engine can be started.*

6. Insert the ignition key into the ignition switch (G, Fig. 20) and turn the key clockwise to the first detent. Wait for the multi-function display to initialize completely. Indicators on the indicator panel should light up and a tone will sound. The battery voltage and preheat indicators may stay lit for 3-30 seconds.

**NOTE:** *The preheat indicator may stay on for longer periods in colder ambient temperatures.*

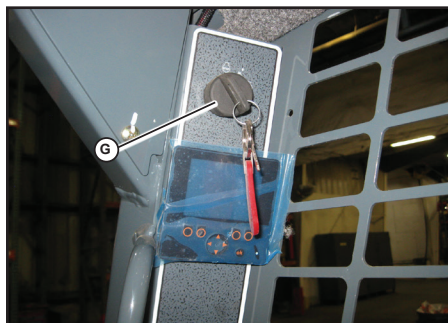

Fig. 20 - Ignition Switch

**NOTE:** *When the key is turned clockwise to the first detent, seat belt indicator activates and a tone sounds for 5 seconds as a reminder to fasten the seat belt.*

7. When the preheat indicator light goes out, Turn the ignition key clockwise until the starter activates. Release the key when the engine starts.
8. If the engine does not start after 15 seconds, turn the ignition key all the way counter-clockwise, wait 1 minute and repeat steps 6-8. If the engine does not start after several attempts, see “Connecting/Disconnecting Attachments” on page 79.
9. Disengage the parking brake.

**IMPORTANT:** *The lift arm and drive hydraulics are inactivated if the parking brake is engaged.*

### **Cold-Starting**

If operating in temperatures below 32°F (0°C), the following are recommended:

- Replace the engine oil with the proper viscosity oil according to the engine operator’s manual.
- Make sure the battery is fully charged.
- Install an optional block heater on the engine. A block heater is recommended for starting

in temperatures below  $-10^{\circ}\text{C}$  ( $14^{\circ}\text{F}$ ). Contact your dealer for engine heater options.

**NOTE:** *In ambient temperatures below  $-10^{\circ}\text{C}$  ( $14^{\circ}\text{F}$ ), an engine block heater is recommended to reduce starter load and aid engine warm up. Starting the machine at these temperatures without a block heater will result in multiple glow/crank cycles or possible extended cranking time approaching 20 seconds.*

### After Starting

Check that charge indicator goes out after the engine starts.

**IMPORTANT:** *If the charge and/or the engine oil pressure indicators do not go out when the engine is running, shut down the engine immediately and correct the problem. Damage to the engine may result if engine is run and the problem is not corrected.*

**IMPORTANT:** *When the machine is not under load, do not run the engine at high speed (above 20% of full throttle) for extended periods of time. Damage to the engine can result.*

**IMPORTANT:** *Do not run a cold engine at full throttle when starting. Stressing a cold engine can damage the engine. Perform the following warm up procedure before using the machine after starting.*

### Engine Warm Up



## WARNING

**Operating the work hydraulics before the hydraulics are warmed up is dangerous, because response will be slow and the machine might move in unexpected ways. Additionally, operating the machine before proper warm-up can also damage the machine. Be sure to sufficiently warm up the machine before starting work.**

**IMPORTANT:** *Do not operate the joystick, hand or hand/foot controls suddenly until the hydraulic oil has reached operating temperature.*

1. After starting, allow the engine to run at low idle for a minimum of 5 minutes with no load (no drive, lift, tilt or auxiliary hydraulic functions).
2. Run the engine at 1800-2000 rpm with no load for 5 minutes.
3. Raise the lift arm so the attachment is off the ground.
4. Extend and retract each of the cylinders several times with no load.
5. Travel slowly forward and backward several times.
6. Additionally, in cold weather, tilt the attachment all the way forward and keep it there for 20-25 seconds. Repeat this step until the attachment tilt speed is normal.

**NOTE:** *Engine speed may be limited during a cold start and/or during a travel drive error condition.*



# OPERATION

---

## Run-In Period

The performance and service life of the machine is heavily dependent on using the machine carefully during its first 100 operating hours.

- Do not operate machine at the maximum rated operating capacity.
- Do not run the engine at a high speed for extended periods of time.
- Increase the load gradually while varying the engine speed.

Follow the maintenance schedule. See "Fig. 20 - Ignition Switch" on page 64.

## Stopping the Engine

Perform the "Mandatory Safety Shutdown Procedure" on page 16.

### CAUTION

**Do not stop the engine at full throttle. Damage to the engine and engine turbocharger can result. Allow the engine to idle for approximately 1 minute before shutting it off.**

---

## Engine Stalling

### WARNING

**If the engine should stall for any reason during operation, always turn the ignition key all the way counter-clockwise to the "OFF" position before re-starting the engine according to "Starting the Engine" on page 63.**

---

## Safety Interlock System (Hydraloc™)

### WARNING

**NEVER defeat the safety interlock system by mechanically or electrically bypassing any switches, relays or solenoid valves.**

---

An interlock system is used on the machine for operator safety. Together with solenoid valves, switches and relays, the interlock system:

- Prevents the engine from starting unless the operator is sitting on the seat and the operator restraint bar is down.
- Disables the lift arm, attachment tilt and wheel drives when the operator leaves the seat, turns the key switch to OFF or raises the restraint bar.
- Disables auxiliary hydraulic system when the restraint bar is raised or the key switch is OFF.

## Testing the Safety Interlock System

Before leaving a parked machine, check the safety interlock system for proper operation:

### Restraint Bar

With the engine running, raise the restraint bar. Move each of the controls. There should be not more than a slight movement of the lift arm, attachment and machine. If there is any significant movement, troubleshoot and correct the problem immediately. Contact your dealer if necessary.

### Seat Switch

With the engine off and the restraint bar lowered, unfasten the seatbelt. Lift your weight up off the seat. Try to start the engine. If the engine starts, turn off the engine, and troubleshoot and correct the problem. Contact your dealer if necessary.

## Travel Drive Operation

### WARNING

Never allow anyone to enter inside the turning radius and the machine path.

Signal your intention to move by sounding the horn (option).

Traveling should be performed with the attachment in transport position.

Avoid sudden stops, starts or turns.

Do not raise the restraint bar while traveling. Raising the restraint bar will apply the parking brake. Loss of control could result.

Do not switch off the ignition switch while traveling. Switching off the ignition automatically applies the parking brake. Sudden braking during travel could result in loss of control.

Visually check behind you before traveling in reverse. Traveling in reverse without checking could result in collision with a person or obstacle.

Remove obstacles in the machine's path before traveling with a load.

## T-Bar Controls

The machine may be equipped with T-bar controls. The left T-bar (H, Fig. 21) controls the drive and the right T-bar (I, Fig. 21) controls the lift and tilt.



Fig. 21 - T-Bar Controls

## T-Bar Drive Controls

Forward, reverse, speed and turning maneuvers are accomplished by movement of the left T-bar. To go forward, push the control forward; for reverse, pull the control rearward. To turn right, turn the control clockwise; to turn left, turn the control counterclockwise. For gradual turns, move the T-bar slightly forward or rearward. For sharp turns, turn the control clockwise or counterclockwise.

Moving the T-bar farther from neutral increase the speed steadily to the maximum travel speed. Tractive effort decreases as speed increases. To get maximum tractive effort, move the T-bar only slightly away from the neutral position. The engine will stall if the control is moved too far forward when loading the bucket.

### WARNING

Be sure the controls are in neutral before starting the engine. Operate the controls gradually and smoothly. Excessive speed and quick control movements without regard for conditions and circumstances are hazardous and could cause an accident.

# OPERATION

## T-Bar Lift and Tilt Controls

Moving the lift arm and tilting the attachment are accomplished by movement of the right T-bar. To raise the lift arm, pull the control straight rearward; to lower the lift arm, push the control straight forward. To tilt the attachment forward and downward, twist the control clockwise; to tilt the attachment up and back, twist the control counterclockwise.

**NOTE:** *The speed of the lift/tilt motion is directly proportional to the amount of T-Bar movement and engine speed.*

To place the lift arm into the detent (“float”) position, push the right T-Bar all the way forward into the detent. This position allows the lowered lift arm to “float” while traveling over changing ground conditions.

### **WARNING**

**Never push the right control handle fully forward to detent the float control with the attachment raised, because this will cause the lift arm to lower very rapidly.**

## Hand/Foot Controls

The machine may be equipped with hand/foot controls. The control grips (J, Fig. 22) control the drive and the foot pedals (K, Fig. 22) control the lift/tilt.

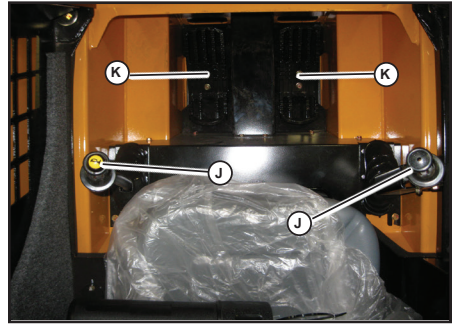

Fig. 22 - Hand/Foot Controls

## Hand/Foot Drive Controls

Forward, reverse, speed and turning maneuvers are accomplished by movement of the control grips. To go forward, push both control grips forward; for reverse, pull both control grips rearward. For turning, move one control grip farther forward or rearward than the other control grip. Turn direction is determined by which control grip is moved farther forward. To turn left, move the right control grip farther forward than the left control grip; to turn right, move the left control grip farther forward than the right control grip. For sharp turns, move the control grips in opposite directions.

Moving the control grips farther from neutral increases the speed steadily to the maximum travel speed. Tractive effort decreases as speed increases. For maximum tractive effort, move the control grips only slightly away from the neutral positions. The engine will stall if the control grips are moved too far forward when loading the bucket.

 **WARNING**

**Be sure the controls are in neutral before starting the engine. Operate the controls gradually and smoothly. Excessive speed and quick control movements without regard for conditions and circumstances are hazardous and could cause an accident.**

### ***Hand/Foot Lift and Tilt Controls***

Moving the lift arm and tilting the attachment are accomplished by movement of the foot pedals. The left pedal raises and lowers the lift arm; the right pedal tilts the attachment. To raise the lift arm, push down on the back of the left pedal with your left heel; to lower the lift arm, push down on the front of the left pedal with the toes of your left foot. To tilt the attachment forward and down, push down on the front of the right pedal with the toes of your right foot; to tilt the attachment up and back, push down on the back of the right pedal with your right heel.

**NOTE:** *The speed of the lift/tilt motion is directly proportional to the amount of pedal movement and engine speed.*

To place the lift arm in the detent (“float”) position, use your toes to push the left pedal all the way down into the detent. This position allows the lowered lift arm to “float” while traveling over changing ground conditions.

 **WARNING**

**Never push the left pedal into the float position with the attachment loaded or raised, because this will cause the lift arm to lower rapidly.**

### **Back-up Alarm**

A back-up alarm system is available which serves to warn people working in the area around the machine of the machine’s rearward movement. The back-up alarm is installed within the engine compartment on the inside surface of the rear door. The alarm emits a tone whenever the machine begins to move in the rearward direction.

 **DANGER**

**Do not rely exclusively on the backup alarm to alert others. Make sure that nobody is within the work area when traveling in reverse.**

# OPERATION

## Joystick Controls

The machine is equipped with joystick controls. On joystick-equipped machines, the left joystick controls the travel drive, and the right joystick controls the attachment lift and tilt.

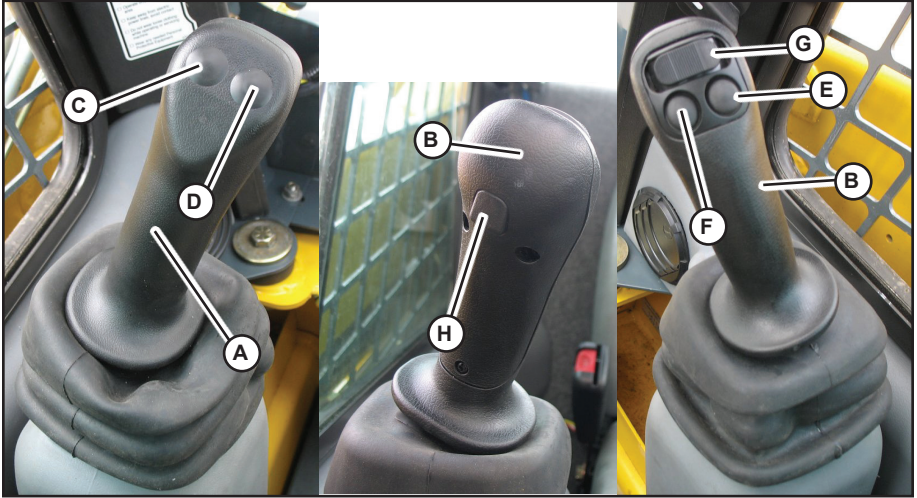

Fig. 23 - Joystick Hand Controls

Table 15 - Joystick Control Functions

Ref.	Control	Description
A	Left Joystick	Controls drive forward, reverse, turn, and speed.
B	Right Joystick	Controls lift arm raise/lower, float, and attachment tilt.
C	Two-Speed Selection Button	Not available on 1050RT machines.
D	Horn Button	Activates horn.
E	Hydraglide™ Button	Activates Hydraglide™.
F	Float Button	Activates Float.
G	Auxiliary Hydraulics Rocker Switch	Controls auxiliary hydraulics flow direction and amount.
H	Auxiliary Hydraulics Continuous Flow Latch Trigger	Works with Auxiliary Hydraulics Rocker Switch to latch/unlatch auxiliary hydraulics continuous flow.

## Joystick Drive Controls (Left Joystick)

Forward, reverse, travel speed and turning maneuvers are controlled using the left joystick (Fig. 24).

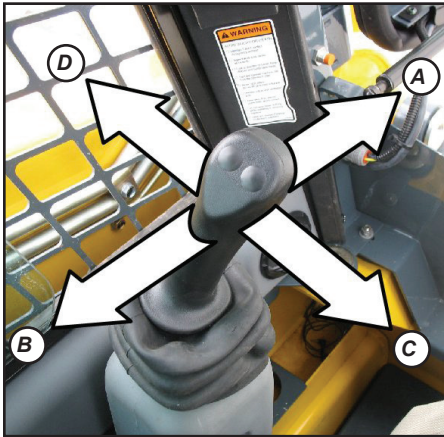

Fig. 24 - Drive Control (Left Joystick)

- To go forward, push the left joystick forward.
- To go in reverse, pull the left joystick rearward.
- To turn right, push the left joystick to the right.
- To turn left, push the left joystick to the left.
- To go forward and to the right, push the left joystick forward and to the right.
- To go rearward and to the right, pull the left joystick rearward and to the right.
- To go forward and to the left, push the left joystick forward and to the left.
- To go rearward and to the left, pull the left joystick rearward and to the left.

## WARNING

Be sure the joystick controls are in neutral before starting the engine. Operate the controls gradually and smoothly. Excessive speed and quick control movements without regard for conditions and circumstances are hazardous and could result in loss of control and cause an accident.

Moving the joystick farther from neutral increases the speed steadily to the maximum travel speed. Tractive effort decreases as speed increases. For maximum tractive effort, move the joystick only slightly away from the neutral position. The engine may stall if the control is moved too far forward when loading the bucket.

## Joystick Lift and Tilt Controls (Right Joystick)

Lift arm raise and lower, and attachment tilt are controlled using the right joystick (Fig. 25).

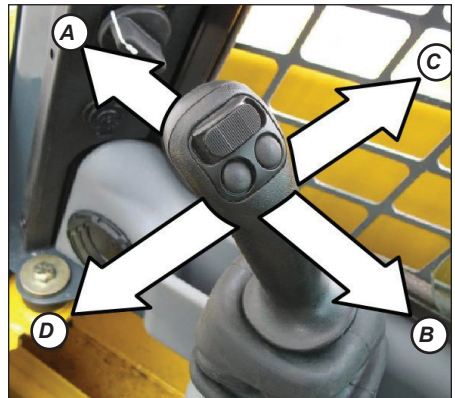

Fig. 25 - Lift/tilt Control (Right Joystick)

- To lower the lift arm, push the right joystick straight forward.
- To raise the lift arm, pull the right joystick straight back.



## OPERATION

---

- c. To tilt the attachment forward and down, move the right joystick to the right.
- d. To tilt the attachment up and back, move the right joystick to the left.
- e. To lower the lift arm while tilting the attachment forward and down, move the right joystick forward and to the right.
- f. To lower the lift arm while tilting the attachment up and back, move the right joystick forward and to the left.
- g. To raise the lift arm while tilting the attachment forward and down move the right joystick rearward and to the right.
- h. To raise the lift arm while tilting the attachment up and back, move the right joystick rearward and to the left.

**NOTE:** *The speed of the lift/tilt motion is directly proportional to the amount of joystick movement and engine speed.*

### **WARNING**

**Be sure the joystick controls are in neutral before starting the engine. Operate the controls gradually and smoothly. Excessive speed and quick control movements without regard for conditions and circumstances are hazardous and could result in loss of control and cause an accident.**

---

### Back-up Alarm

A back-up alarm system is available which serves to warn people working in the area around the machine of the machine's rearward movement. The back-up alarm is installed within the engine compartment on the inside surface of the rear door. The alarm emits a tone whenever the machine begins to move in the rearward direction.

### **DANGER**

**Do not rely exclusively on the backup alarm to alert others. Make sure that nobody is within the work area when traveling in reverse.**

---

### Rubber Track Use Cautions and Tips

Carefully following the recommendations in this section will result in better track wear performance.

**CAUTION**

If possible, avoid traveling over broken or jagged stone, metal objects, on other sharp objects that could damage or cut the tracks.

Inspect tracks and undercarriage components for wear frequently. Worn components accelerate track wear

If possible, avoid traveling in areas with loose rocks that could get stuck in the tracks, or between the tracks and the track wheels.

Avoid using the machine in salt water areas. Salt can corrode the metal cores in the tracks.

Clean any fuel, oil, salt, fertilizer or chemical solvents that might get on the tracks. These substances could corrode the metal cores in the tracks.

Avoid traveling on roads immediately after asphaltting, or on other hot surfaces or over fires. Damage to the tracks could result.

If climbing steps or cobblestone, avoid climbing at an angle. Climb straight up the slope and do not change course at the top of the slope.

When climbing slopes. Do not suddenly change course at the point where the slopes starts.

Avoid traveling with one track on a slope or other raised surface and the other track on a flat surface.

Harder surfaces cause accelerated track and undercarriage component wear. Avoid sharp and spin turns on hard surfaces such as concrete.

Avoid drops that cause severe blows to the tracks.

High-speed operation and track slippage accelerate track and

undercarriage component wear.

**Avoid rubbing the sides of the tracks against walls or other vertical surfaces.**

It is impossible to estimate track life because track life is affected by operating conditions, maintenance and application.

Due to varying applications, there is no wear guarantee on rubber tracks. As a “rule of thumb,” however, rubber track life expectancy for track machines in “dirt” applications can be up to 2 to 2-½ times the normal life of a set of pneumatic tires on a skid-steer machine.

**IMPORTANT:** *Track damage caused by heavy and/or abusive use is not covered under warranty. Damaged tracks cannot be repaired and must be replaced.*

To extend track life, the IdealTrax™ track tension is loosened when the engine is not running. When the engine is started, the tracks are automatically adjusted to the correct tension. Monitor the tracks at startup to ensure the automatic track tensioning system is working properly. Tracks running loose can de-track. Over-tightened tracks can cause power loss, excessive roller, idler bearing and sprocket wear, and track tearing.

Tracks and undercarriage should be cleaned regularly. Mud and/or debris buildup in the track rollers, sprockets and/or undercarriage structure can accelerate track wear. It prevents proper engagement between the mating surfaces of sprocket teeth and track links, can cause the tracks to be crowded off the rollers, and may prevent roller rotation, leading to roller and/or track failure. IdealTrax™ makes cleaning tracks and undercarriage easier due to increased clearance provided when the machine is off and tension on the tracks is relaxed.

Constant operation on slopes, side hills, crowns and depressions accelerates guide lug, idler, roller, and sprocket wear. Avoid cutting across slopes. Instead, drive up or down them. It is best to climb straight up or down, and



# OPERATION

---

then turn when the machine is in a more level location.

Alternate turning direction from one side to the other. Always turning in one direction can accelerate sprocket tooth, track tread, guide lugs and roller flange wear.

Unnecessary track slippage accelerates undercarriage and track wear and can cut tracks. Avoid track slippage when driving into material and dig using the lift/tilt hydraulics. Be aware when track slippage occurs and adjust machine operation to prevent it.

Avoid making spin turns or pivot turns, which accelerate wear and cause de-tracking. Always make wide turns whenever possible.

Don't allow the sides of the tracks to strike against objects such as curbs or walls.

Avoid traveling with one track on a slope or a projecting object and the other track on a flat surface. Travel with both tracks on a level surface if possible. Operating tracks with the outside or inside edge of the track turned up on a curb, mound or stone can crack tracks or shear the rubber.

Operate slowly and carefully. High-speed operation accelerates wear on all undercarriage and track components.

Avoid traveling or operating on broken stone, jagged base rock, iron rods, scrap iron or other recycling-type materials. Rubber tracks are not intended for these surfaces.

Working in heavily stone-laden soils or conditions can cause damage or de-tracking due to stones becoming lodged in the idler or drive sprockets.

Rubber tracks are not intended for use in quarry, recycling or demolition applications.

Rubber track machines are not intended for use with cold planers.

Harder surfaces cause accelerated wear on track treads, links, rollers, idlers, sprockets and other undercarriage components. To minimize wear, avoid routinely driving and turning on hard surfaces like asphalt and concrete.

Avoid allowing fuel, oil, salt or fertilizer to get on the tracks. These substances can corrode the metal cores in the rubber tracks. If these materials come in contact with the tracks, flush the tracks and undercarriage with clean water to remove the damaging materials.

Avoid operating in job sites where there are sharp objects, such as jagged rocks or broken concrete, which can damage the lug surface of the tracks. Use common sense when operating in conditions which are potentially damaging to rubber tires, because the same conditions are damaging to rubber tracks as well. Damaged tracks cannot be repaired and must be replaced, and are not warrantable for failures under these conditions.

Excessively worn undercarriage components will damage tracks. Monitor these components to ensure maximum track life. If replacing tracks, replace any worn undercarriage components at the same time.

Listen for unusual or loud track/undercarriage noises during operation. Loud/unusual noises often indicate worn tracks/undercarriage.

## Sprocket Tooth Wear and Track Life

Worn sprockets are a typical cause of track damage and abnormal track noise. Check for sprocket wear often. Sprocket wear (B, Fig. 26) normally occurs along the sides and crests of the sprocket teeth (C, Fig. 26). Use the sprocket tooth wear gauge (A - Manitou part # 50323051), included with the machine, to determine exact sprocket tooth wear:

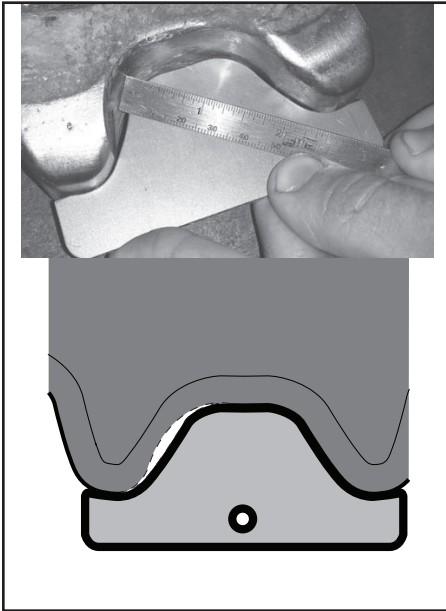

**Fig. 26 - Sprocket Tooth Wear Gauge**

- Hold the sprocket tooth wear gauge (A) against the sprocket teeth at the centerline of the sprocket as shown in the photograph. Wear gauge (A) has the same profile as the teeth on a new sprocket.
- Sprocket wear is considered excessive if 1/8" (4mm) of material is worn from any point along the sprocket tooth profile.
- Worn sprockets cannot be repaired and should be replaced. Refer to the parts manual for your machine for sprocket service part numbers when ordering. Rotating sprockets by swapping them from one side to the other can extend their service life, provided the wear is limited to one direction of travel.

**IMPORTANT:** *New tracks perform better and last longer with new sprockets because the mating surface profiles are matched.*

## ⚠ CAUTION

Always replace sprocket mounting hardware when replacing or re-attaching sprockets.

### Lift Arm Operation

## ⚠ WARNING

Do not lift loads exceeding rated operating capacity. See "Payloads/Capacities" on page 39.

- Attachment Transport Position: Carry materials 200-300 mm (8-12") above the ground, and adjust as necessary to clear obstacles. Generally, carry the load as low as safely possible. Tilt buckets back, as shown in Fig. 27, to prevent spilling material.

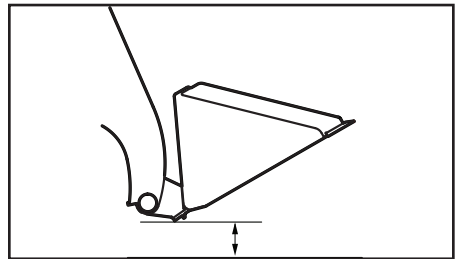

**Fig. 27 - Transport Position**

# OPERATION

## Lift Arm Lift Support



A falling lift arm could result in severe injury or death.

If the lift arm must be left in the raised position, **BE SURE** to properly apply the lift arm support device.

The operator must not leave the operator's position if the lift arm is in the raised position unless the lift arm support device is properly applied.



A second person on the outside of the machine is required to assist with applying the lift arm support.

## Engage Lift Arm Support

1. Empty and remove the attachment.
2. Bring the machine to a complete stop on a level surface.
3. Raise the lift arm as high as it will go.
4. Move the drive controls to the neutral position.
5. Shut off the engine.



The lift arm should remain in the raised position when the engine is stopped. If the lift arm is observed moving from the raised position, stay in the operator's position, lower the lift arm and exit the machine. Have the machine serviced by an authorized dealer before operating again.

6. Move the lift/tilt controls to verify that the controls do not cause movement of the lift arm and hitch plate.
7. Raise the restraint bar to disable the hydraulic controls.
8. Stay in the machine sitting in the operator's position. A second person, on the outside of the machine, must:
  - a. Remove retaining fastener (L, Fig. 28) securing lift arm support (M) in the storage position.

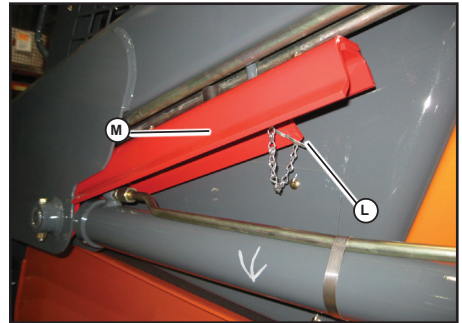

Fig. 28 - Lift Arm Support Device in Storage Position

- b. Position the lift arm support (M, Fig. 29) over the lift arm cylinder rod (N, Fig. 29).

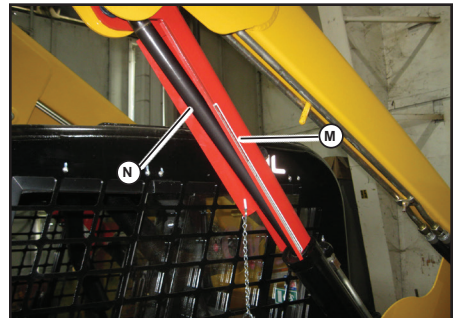

Fig. 29 - Lift Arm Support Applied

9. Start the machine and lower the lift arm against lift arm support (M). Verify that lift arm support (M) is properly positioned as shown in Fig. 29.

## WARNING

**The lift arm support device must be properly positioned to prevent the lift arm from falling, which could result in severe injury or death.**

10. Shut off the engine and remove the ignition key.
11. Move the lift/tilt controls to verify that the controls do not cause movement of the lift arm and hitch plate.
12. Unfasten the seat belt and raise the restraint bar. Exit the machine using the hand-holds. Take the ignition key with you.

### *Disengage Lift Arm Support*

## WARNING

**A second person on the outside of the machine is required to assist with disengaging the lift arm support.**

1. Start the engine and raise the lift arm as high as it will go.
2. Move the drive controls to the neutral position.
3. Shut off the engine.
4. Move the lift/tilt controls to verify that the controls do not cause movement of the lift arm and hitch plate.
5. Raise the restraint bar to disable the hydraulic controls.
6. Stay in the machine in the operator's position. A second person, on the outside of the machine, must:

- a. Remove lift arm support (M, Fig. 29) from the cylinder rod.
- b. Reinstall the lynch pin through the welded steel post on the lift arm (O Fig. 30).



**Fig. 30 - Lynch pin securing lift arm support device in the storage position.**

### ROPS/FOPS Cab

## DANGER

**Do not remove or modify the Roll-Over Protective Structure/Falling Object Protective Structure (ROPS/FOPS) unless instructed to do so in Manitou-approved installation instructions. Modifications, such as welding, drilling or cutting, can weaken the structure and reduce the protection it provides. A damaged ROPS/FOPS cannot be repaired – it must be replaced.**

**The ROPS/FOPS must be replaced if an rollover incident occurs. The protection offered by the ROPS/FOPS will be impaired if it has been damaged in a rollover incident.**

### Tilt ROPS/FOPS

Tilting up the ROPS/FOPS provides access to hydraulic, fuel, and electrical components.

# OPERATION

## Raising ROPS/FOPS

### **WARNING**

Always secure the ROPS/FOPS to the chassis with anchor bolts and washers (A, Fig. 31) before driving or using the machine.

Always close the swing-out cab door (if equipped) before tilting the ROPS/FOPS.

Stay clear from underneath the ROPS/FOPS as it is tilted.

Check ROPS/FOPS tilt component condition at regular intervals. Replace damaged or worn parts immediately.

1. Perform the “Mandatory Safety Shutdown Procedure” on page 16.
2. Remove anchor bolts and washers (A, Fig. 31) securing the front of the ROPS/FOPS to the chassis.

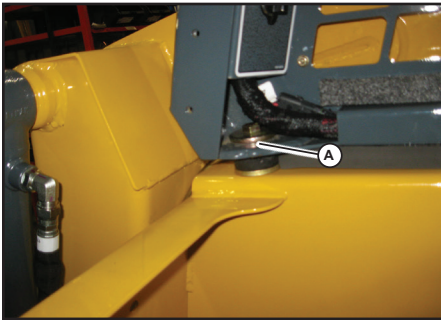

Fig. 31 - ROPS/FOPS Anchor Fastener

**IMPORTANT:** BEFORE raising the ROPS/FOPS, position the seat as far back as it will go. Avoid damaging control handles by slowly raising the ROPS/FOPS. BE SURE the control handles clear the ROPS/FOPS.

3. On machines equipped with a swing-out cab door, securely close and latch the door.
4. Close the engine cover.
5. Lift ROPS/FOPS up and tilt it back until the self-actuating lock mechanism engages. The lock mechanism locks the ROPS/FOPS in a rolled-back position (B, Fig. 32).

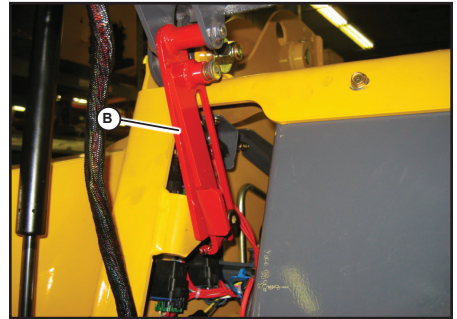

Fig. 32 - ROPS/FOPS lock shown engaged

**NOTE:** Gas springs balance the ROPS/FOPS to aid raising and lowering.

## Lowering ROPS/FOPS

1. With an assistant’s help, apply upward force on the ROPS/FOPS while pulling the self-actuating lock mechanism handle (B, Fig. 32) toward the front of the loader.
2. Lower the ROPS/FOPS until it contacts the chassis.

**IMPORTANT:** Avoid damaging control handles by slowly lowering the ROPS/FOPS. MAKE SURE the control handles clear the ROPS/FOPS.

## CAUTION

Stay clear from underneath the ROPS/FOPS as it is tilted down. Injury to limbs can result.

- Secure the ROPS/FOPS to the chassis with anchor bolts, and washers. Torque anchor bolts to 102 Nm (75 lb.-ft.).

## WARNING

Always secure the ROPS/FOPS to the chassis with anchor bolts and washers (A, Fig. 31) before driving or using the machine.

### Self-Leveling (Option)

Self-leveling automatically keeps the tilt angle of the attachment constant, relative to the ground plane, (Fig. 33) when the lift arm is raised (A). This feature is especially useful when using pallet forks.

**IMPORTANT:** *Self-leveling operates only when the lift arm is raised: when the lift arm is lowered (B), self-leveling is not activated.*

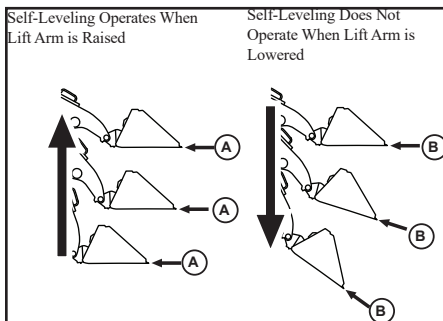

Fig. 33 - Self-Leveling Operation

### Float Control

## WARNING

Never use the float mode with the attachment raised, because this will cause the lift arm to lower very rapidly. The float mode can be used where the engine has stopped, is unable to be started, and lowering the lift arm is necessary to allow the operator to exit the loader.

For Hand/Foot loaders, use your toes to push the left foot pedal all the way down to detent the float control. For T-Bar loaders push the right control handle fully forward to detent the float control. This mode allows the lowered lift arm to follow the ground contour while traveling over changing ground conditions. For Hand/Foot loaders, use your heel to push the left foot pedal up to horizontal to deactivate. For T-bar loaders, pull the right control handle rearward to deactivate. The float mode is automatically deactivated when the machine is shut off.

For Joystick loaders, press the float button on the right control handle. Press float button for 5 seconds to activate continuous float. Press button again to deactivate continuous float.

### Connecting/Disconnecting Attachments

## WARNING

To prevent unexpected release of the attachment from the hitch, be sure to secure the latch pins by rotating the levers all the way to the hitch. Locking pins must be fully engaged through the holes in the attachment frame before using the attachment. The attachment could fall off if it is not locked on the hitch and cause serious injury or death.



# OPERATION

The machine features a All-Tach™ attaching mechanism for mounting a bucket or other attachment. Two latch levers engage the latch pins to secure the attachment.

## Connecting Attachments

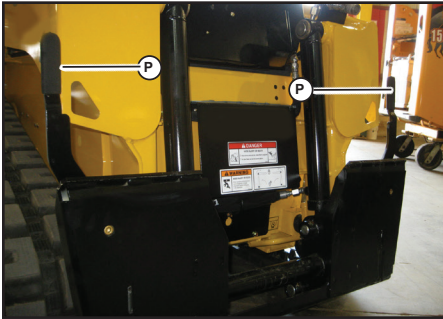

**Fig. 34 - Hitch for Attachments**

1. Rotate the latch levers (P, Fig. 34) to a vertical position to fully retract the latch pins.
2. Start the machine engine and be sure the lift arm is lowered and in contact with the machine frame.
3. Align the machine squarely with the back of the attachment.
4. Tilt the hitch forward until the top edge of the hitch is below the flange on the back side of the attachment and centered between the vertical plates.
5. Slowly drive the machine forward and, at the same time, tilt the hitch back to engage the flange on the back side of the attachment.
6. Stop forward travel when the flange is engaged, but continue to tilt the hitch back to lift the attachment off the ground.
7. Exercise the “Mandatory Safety Shutdown Procedure” on page 16.
8. With the machine engine OFF, leave the operator’s compartment and rotate the latch levers all the way to the hitch to fully engage the latch pins.

**IMPORTANT:** To check that the attachment is properly installed tilt the attachment forward slightly, apply downward pressure to the attachment prior to operating.

## Disconnecting Attachments

1. Tilt the hitch back until the attachment is off the ground.
2. Exercise the “Mandatory Safety Shutdown Procedure” on page 16.
3. Relieve any hydraulic pressure in the auxiliary and attachment lines:
  - a. Turn the key switch, but do not start the engine.
  - b. With the restraint bar down, move the auxiliary hydraulic control back and forth. This will relieve the pressure in the hydraulic system.
4. With the engine OFF, leave the operator’s compartment, disconnect the auxiliary hydraulic hoses and rotate the latch levers completely vertical to fully retract the latch pins.
5. Start the engine and be sure that the lift arm is fully lowered and in contact with the machine frame.
6. Tilt the hitch forward and slowly back the machine away until the attachment is free from the machine.

## Powering Attachments with Hydraulic Function

Hydraulically-powered attachments are powered using the auxiliary hydraulics circuits.

**NOTE:** With the engine OFF, key in the ON position and the restraint bar down, the auxiliary hydraulic control can be moved to relieve any pressure in the hydraulic system.



**Fig. 35 - Auxiliary Hydraulic Circuit Connections**

The hydraulic couplers are located on the left lift arm. “A” port is pressure (A, Fig. 35) “B” port is return (B, Fig. 35) when the auxiliary control is in the detent position.

### **Connecting Hydraulic Attachments to the Auxiliary Hydraulic Circuits**

**IMPORTANT:** *Connect hydraulically-powered attachment hoses to the auxiliary circuits after the attachment is secured to the hitch*

*Disconnect hydraulically-powered attachment hoses from the auxiliary circuits before removing the attachment from the hitch.*

1. Empty the attachment and lower it to the ground.
2. Shut off the engine and turn off the ignition. Remove the ignition key and take it with you.
3. Raise the restraint bar.
4. Clean the hydraulic connections on the hoses and the connections.
5. Relieve the pressure in the standard auxiliary hydraulics circuit.
6. Push the hose connections firmly onto the auxiliary hydraulic connections until they snap into place.

## **⚠ CAUTION**

**Route the hydraulic hoses so they do not get pinched when the attachment is tilted forward and back. Damaged or burst hydraulic hoses could result.**

**IMPORTANT:** *Always check hydraulic function of the attachment before use, to make sure the hydraulic hoses have not been installed in reverse.*

**NOTE:** *Pressure buildup caused by heat in hydraulic attachments left in direct sunlight can make it difficult to connect the quick-couplers to the fittings on the attachment.*

### **Disconnecting Hydraulic Attachments from the Auxiliary Hydraulics Circuits**

1. Empty the attachment and lower it to the ground.
2. Shut off the engine and turn off the ignition. Remove the ignition key and take it with you.
3. Raise the restraint bar.
4. Relieve the pressure in the standard auxiliary hydraulics circuit.
5. Push on the hose connection locking rings until the hose connections release.



# OPERATION

## Auxiliary Hydraulics Operation

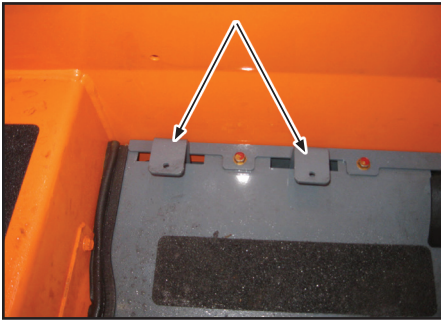

**Fig. 36 - T-Bar Auxiliary Hydraulics Control Pedal**

For T-Bar controls, a foot pedal is used to control the direction of hydraulic oil flow.



**Fig. 37 - Hand/Foot Auxiliary Hydraulics Control Handle**

For Hand/Foot controls, the right handle controls the direction of the hydraulic oil flow. A locking pin (C, Fig. 37) locks it in the “UP” position for continuous operation.

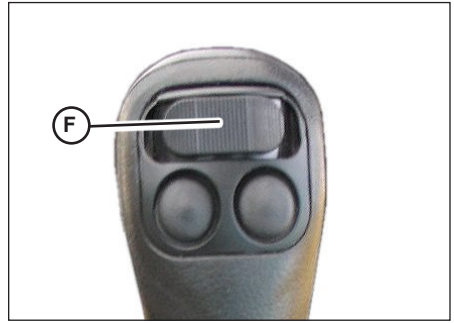

**Fig. 38 - Joystick Auxiliary Hydraulics Control Rocker Switch**

1. Empty the attachment and lower it to the ground.
2. Shut off the engine. With the ignition on, but the engine off, move the auxiliary hydraulics control rocker switch (F, Fig. 38) on the right joystick back and forth to relieve pressure in the auxiliary hydraulics circuit.
3. Turn off the ignition. Remove the ignition key and take it with you.
4. Raise the safety bars/arm rests and exit the machine using the hand holds.
5. Clean the hydraulic connections on the hoses and the connections.
6. Relieve any residual pressure remaining in the auxiliary hydraulics circuit by pushing the attachment coupler firmly into the auxiliary coupler.

### CAUTION

**Route the hydraulic hoses so they do not get pinched when the attachment is tilted forward and back. Damaged or burst hydraulic hoses could result.**

7. Continue to push the hose connections firmly onto the auxiliary hydraulic connections until they snap into place.

**IMPORTANT:** *Always check hydraulic function of the attachment before use, to make sure the hydraulic hoses have not been installed in reverse.*

**NOTE:** *Pressure buildup caused by heat in hydraulic attachments left in direct sunlight can make it difficult to connect the quick-couplers to the fittings on the attachment.*

**NOTE:** *The auxiliary hydraulic couplers are located on the left lift arm. When the auxiliary control switch is activated in either direction, the inside and outside couplers can be “pressure” or “return”, depending on which direction the switch is activated. The smaller center coupler is for the case drain.*

## Working with Buckets

Buckets are mainly used for digging, loosening, lifting, transporting and loading loose or solid materials.



## WARNING

**Make sure the bucket is securely attached to the hitch before starting work.**

**Avoid tilting a bucket back when the lift arm is fully raised. Material may fall over the rear of the bucket and onto the operator. If necessary, fit the rear of the bucket with a guard to prevent material from falling out of the back of the bucket.**

**Always carry the loaded bucket with the lift arm in the transport position. For additional stability when operating on inclines, always travel with the heavier end of the machine toward the top of the incline.**

**Make sure you have a good view of the material you are digging, and of the area you will be working in.**

**Use extreme care when digging around foundations or walls. Never remove material that might compromise a wall or foundation.**

**Never push the “float” button with the bucket or attachment raised, because this will cause the lift arm to fall.**

**Always maintain a safe distance from electric power lines and avoid contact with any electrically charged conductor or gas line. Accidental contact or rupture can result in electrocution or an explosion. Contact the “Digger’s Hot-line” or proper local authorities for utility line locations before starting to dig.**

# OPERATION

---



## WARNING

Read the “Safety” section in this manual, starting on “Safety” on page 15, before working with a bucket. Pay special attention to the “During Operation” information, starting on “During Operation” on page 18.

Always follow the information included in the “Safety” section. Serious injury or death can occur if the safety information is not followed.

Make sure the bucket is securely attached to the hitch before starting work. Refer to “Connecting Attachments” on page 80.

---

### *Digging Tips*

When completing a digging task:

- When digging in a pit, exit the pit outside the digging line, through an area as level as possible.
- If possible, dig by removing adjacent strips.
- Drive forward when transporting a full bucket out of the digging area.



## WARNING

Avoid tilting a bucket back when the lift arm is fully raised. Material may fall over the rear of the bucket and onto the operator’s position.

When on slopes, always set the lift arm to the transport position (“a. Attachment Transport Position: Carry materials 200-300 mm (8-12”) above the ground, and adjust as necessary to clear obstacles. Generally, carry the load as low as safely possible. Tilt buckets back, as shown in Fig. 27, to prevent spilling material.” on page 75) and tilt the bucket fully back.

Secure heavy or awkward loads. If necessary, fit the rear of the bucket with a guard to prevent material from falling out of the back of the bucket.

Whenever possible, drive in reverse when transporting a bucket loaded with material down a steep slope.

Make sure you have a good view of the material you are digging, and of the area you will be working in.

---

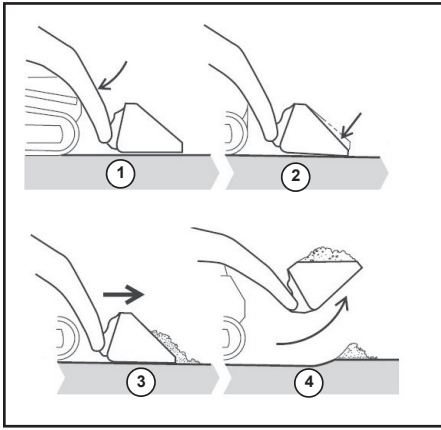
**Digging with a Standard Bucket****Fig. 39 - Digging with a Bucket**

1. Approach the digging site with the lift arm slightly raised. Tilt the bucket forward until the cutting edge contacts the ground.
2. Tilt the cutting edge of the bucket down at an angle appropriate for ground hardness.
3. Drive forward slowly, digging into the ground with the cutting edge of the bucket and gradually lower the lift arm.
4. When the bucket is full, raise the bucket and tilt it back and back away from the material.

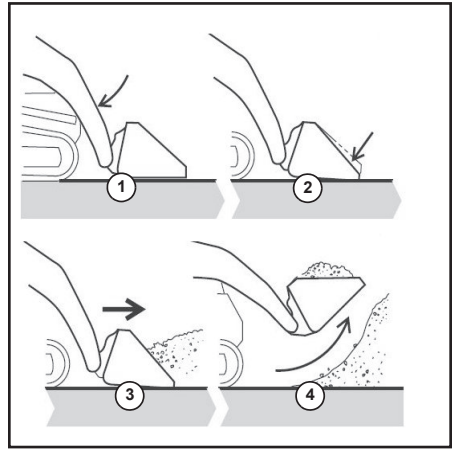
**Loading a Bucket****Fig. 40 - Loading a Bucket**

1. Lower the bucket to the ground.
2. Tilt the bucket slightly forward so the bucket cutting edge is pointing slightly down into the ground.
3. Drive forward until the bucket is filled with material. Adjust the bucket tilt as needed to remove an even layer of ground and to reduce track slip.
4. Tilt the bucket back and raise it to scoop up material.
5. Reduce engine speed and back out of the material.
6. Set the bucket to transport position.

# OPERATION

## Loading Trucks (or Hoppers)

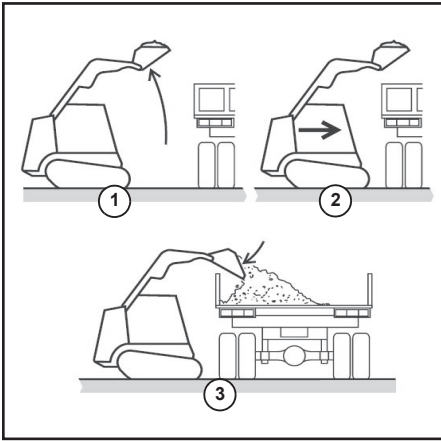

Fig. 41 - Dumping into a Truck (or Hopper)

**IMPORTANT:** *When the self-leveling feature is on, the tilt angle of the attachment is kept constant, relative to the ground plane, when the lift arm is raised: when the lift arm is lowered however, self-leveling is not activated.*

1. Approach the truck and stop, allowing for clearance to raise the lift arm and loaded bucket, and raise the bucket until the lower edge of the bucket clears the truck bed.
2. Drive slowly forward and stop with the bucket over the inside of the truck.
3. Tilt the bucket forward and dump the material into the truck bed.
4. When the truck is half-loaded, use the bucket to spread the load evenly.
5. Back away from the truck while tilting the bucket back and lowering the lift arm.

## Tips When Loading Trucks

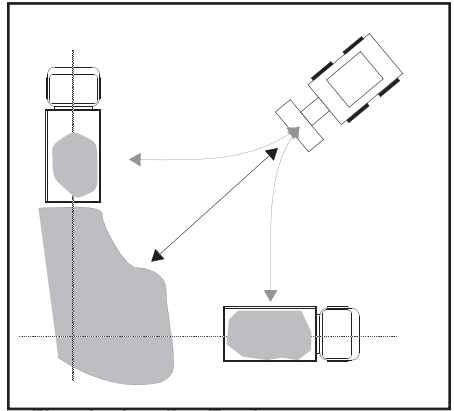

Fig. 42 - Loading Trucks

1. The truck and machine working direction should form an angle of 45°.
2. Only raise a full bucket to the height needed for dumping when you are driving in a straight line toward the truck.
3. Dump with the wind behind you to keep dust away from your face, air filters and fans.

## Backfilling Holes and Embankments

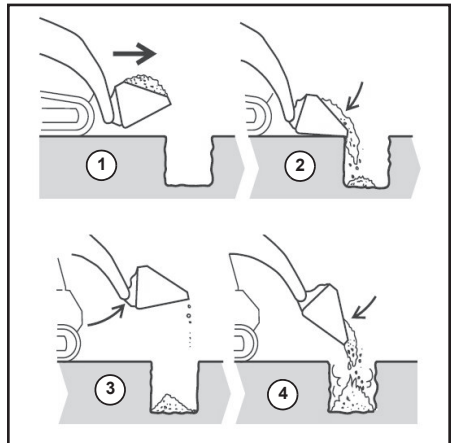
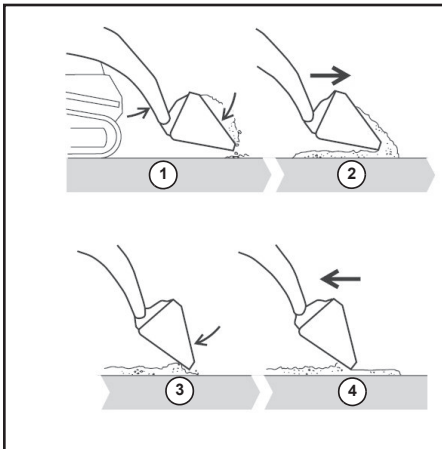

Fig. 43 - Backfilling

1. Lower the bucket a few inches from the ground. Slowly drive forward until the front edge of the bucket extends halfway over the edge of the hole or embankment.
2. Tilt the bucket forward to dump the material.
3. Tilt back and raise the bucket. Inspect the hole/embankment for proper filling.
4. Continue to dump material as necessary for proper fill.
5. Back away from the embankment while tilting the bucket back and lowering the lift arm.

## Grading without Float



**Fig. 44 - Grading without Float**

1. Raise the bucket slightly and tilt it forward.
2. Release material from the bucket while traveling forward.
3. Tilt the bucket forward and adjust the lift arm height until the cutting edge is slightly above the ground.
4. Drive in reverse, smoothing the material released in step 2 with the front edge of the bucket.

## Grading Using Float

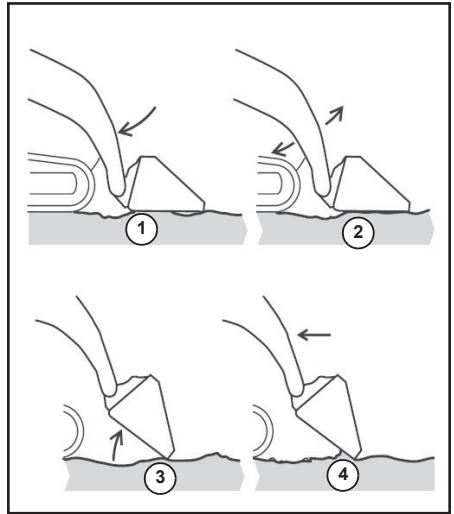

**Fig. 45 - Grading Using Float**

1. Lower the bucket to the ground.
2. Activate the lift arm float. See “T-Bar Drive Controls” on page 67 or “Hand/Foot Drive Controls” on page 68.
3. Tilt the bucket forward so it stands on the cutting edge at a 30°-45° degree angle to the surface being leveled.
4. Drive in reverse, dragging the floating bucket. Adjust the tilt angle of the bucket while driving in reverse to control the spread of the material.

# OPERATION

---

## Working with Pallet Forks



### WARNING

Read the “Safety” section in this manual, starting on “Safety” on page 15, before working with pallet forks. Serious injury or death can occur if the safety information is not followed. Pay special attention to the “During Operation” information, starting on “During Operation” on page 18.

Follow all instructions provided with the pallet forks.

Use only approved pallet forks. Use special caution and maintain tilt control at all times when using pallet forks.

Always approach the load from a straight-ahead position.

Position the fork arms as far apart as possible, as allowed by the load.

Load both fork arms evenly, positioned under the pallet as far as they will go.

Lift, transport and unload loads only on firm and level ground with sufficient load-bearing capacity.

Always transport the load close to the ground as is safely possible. Observe minimum ground clearance.

Use pallet forks for material handling and/or material transport only.

Never lift a load using only one fork arm.

Make sure the fork arms are safely locked onto the fork frame before use.

Do not lift unstable material, or material that is not properly secured on the fork arms.

Never leave a machine with the forks raised or a load unattended. Make sure all persons stay clear of suspended loads.



### WARNING

DO NOT exceed pallet fork load center and/or lifting capacity. Refer to the pallet fork payload /capacities table on page 83.

Do not use high travel speed range when using pallet forks.

DO NOT use standard fork arms as reverse (inverted) forks.

Never allow a load to get closer than 6 m (20 ft.) to overhead electrical lines.

DO NOT push, pull or shove the fork arms, or move them in at a slanting angle; the resulting lateral forces can damage the fork arms.

DO NOT pull loads off the fork arms, or allow loads to fall onto the forks arms.

DO NOT tilt the pallet forks to raise loads.

DO NOT lift or transport molten material with pallet forks.

Repair work on fork arms must be performed only by authorized personnel.

Always keep pallet fork arms clean.

Secure loads as directed in the pallet fork Operator’s Manual to prevent the loads from falling.

Never modify pallet fork arms.

Do not lift or transport persons on the pallet forks.

Do not drive on public roads with pallet forks installed on the machine.

Do not stack loads which are not properly packaged or have damaged pallets/stacking containers. Do not stack loads on top of loads, which may have shifted.

Always tilt pallet forks back slightly during transport to help retain the load.

**WARNING**

**Do not use bent, cracked, or otherwise damaged fork arms/pallet forks.**

**Always inspect pallet forks each time before using. Refer to the pallet fork manufacturer's documentation and/or contact the pallet fork manufacturer for information regarding safe pallet fork condition criteria:**

- **Check the fork arm locks for proper function and/or damage. Do not use pallet forks with damaged locks or locks that do not function properly.**
- **Visually check the fork arm hooks and/or bends for cracks and/or deformations. Do not use fork arms that are cracked and/or have deformations that make the fork arms unsafe.**
- **Do not use fork arms that have bends or blades that have more than 10 percent of the original material worn away.**
- **Check the fork arms blades and tips for deformations or holes..**

### **Transporting Loads Using Pallet Forks**

**IMPORTANT:** *When the self-leveling feature is on, the tilt angle of the attachment is kept constant when the lift arm is raised. When the lift arm is lowered, self-leveling is not activated. Refer to "Self-Leveling (Option)" on page 79 for more information about the self-leveling feature.*

### **Loading Pallet Forks**

1. Stop the machine immediately in front of the material

2. Position the fork arms parallel to the ground.
3. Make sure the fork arms are adjusted as far apart as possible, as allowed by the load, and are both the same distance away from the center-line of the load.
4. Adjust the height of the fork arms to fit the lifting area at the bottom of the pallet.
5. Drive slowly and carefully forward until the fork frame contacts the material.
6. Make sure the pallet is evenly and safely positioned on the pallet fork arms.

### **Lifting Loads Using Pallet Forks**

7. Apply the parking brake.
8. Slowly raise the pallet forks. Do not raise the pallet forks any higher than required. Make sure to not exceed pallet fork load center and/or lifting capacity. Refer to "Payloads/Capacities" on page 39.
9. Lower the load immediately if you are unsure of the load, the equipment, or in case of any unsafe circumstances.
10. Tilt the pallet fork frame back slightly, to help retain the load.

### **Transporting Loads Using Pallet Forks**

11. Make sure the area around and behind the machine is clear of bystanders and obstacles.
12. Slowly and carefully drive in reverse and lower the pallet forks to transport position when it is safe to do so. Refer to "a. Attachment Transport Position: Carry materials 200-300 mm (8-12") above the ground, and adjust as necessary to clear obstacles. Generally, carry the load as low as safely possible. Tilt buckets back,



## OPERATION

---

as shown in Fig. 27, to prevent spilling material.” on page 75.

13. Carry the load as low as safely possible during transport. Observe minimum ground clearance.
14. Drive slowly and carefully forward directly toward the place where the load will be set down.

### Setting Down Loads Using Pallet Forks

**NOTE:** *If the load will be placed on top of stacked material, make sure to align the load in the center of the stack.*



**Do not stack loads which are not properly packaged or have damaged pallets/stacking containers. Do not stack loads, or on top of loads, which have shifted.**

---

15. Raise the pallet forks slightly above where the load will be placed.
16. Tilt the pallet forks as needed to level the fork arms.
17. Carefully drive slowly forward until the load is positioned precisely above where the load will be placed. Use care when aligning the load with a stack.
18. Slowly and carefully lower the lift arm until the load is placed.
19. Make sure the fork arms are no longer bearing weight and are free to be retracted.
20. Make sure the area around and behind the machine is clear of bystanders and obstacles.

21. Slowly and carefully drive in reverse away from the placed load until the lift arm can be lowered to transport position. Refer to “a. Attachment Transport Position: Carry materials 200-300 mm (8-12”) above the ground, and adjust as necessary to clear obstacles. Generally, carry the load as low as safely possible. Tilt buckets back, as shown in Fig. 27, to prevent spilling material.” on page 75.
22. Slightly tilt the pallet fork frame backwards.

### Diesel Particulate Filter (DPF) Regeneration Procedures

The Diesel Particulate Filter (DPF) treats exhaust emissions in compliance with Tier 4 / Stage 3B emission standards. The DPF filter relies on high exhaust temperatures. Periodic DPF maintenance (regeneration) is required, dependent upon machine operation load / temperature.

**NOTE:** *Machines operated primarily at high loads and operating temperatures require less frequent DPF maintenance. Extended periods of engine idling rapidly increases DPF soot levels, requiring more frequent regeneration operations.*

There are three modes of DPF regeneration:

**Passive / Assist Regeneration:** Occurs automatically without operator input. Passive/assist regeneration does not affect machine operation.

**Reset Regeneration:** Occurs automatically, but can be inhibited by the operator. Increases exhaust gas temperatures. Reset regeneration occurs approximately every 100 hours of operation. See “Reset Regeneration” on page 91.

**NOTE:** *Reset regeneration effectiveness is improved if the machine is operated at mid- to high-throttle settings when reset regeneration mode is in progress.*

**Stationary Regeneration:** Requires operator action to initiate and takes approximately

25-30 minutes to complete. See “Stationary Regeneration” on page 92.

**IMPORTANT:** *The machine cannot be operated and must be parked in a well-ventilated area away from flammable materials when stationary regeneration is in progress.*



There is a possibility of carbon monoxide poisoning if stationary regeneration occurs in an enclosed space. Always perform stationary regeneration in a well-ventilated area.



During regeneration, there will be high exhaust gas temperatures, even at low load. Stay clear of the DPF during regeneration.

## Reset Regeneration

**IMPORTANT:** *Reset regeneration can be prevented from occurring. See “Reset Regeneration Inhibit” on page 91.*

Reset regeneration occurs automatically (unless inhibited) approximately every 100 hours of operation.

**NOTE:** *Reset regeneration effectiveness is improved if the machine is operated at mid- to high-throttle settings while regeneration is in progress.*

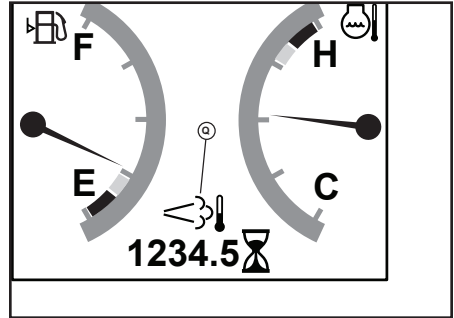

Fig. 46 - Reset Regeneration In Progress

When reset regeneration occurs, the DPF in-progress (elevated temperature) symbol (Q, Fig. 46) displays on the screen.

## Reset Regeneration Inhibit

DPF regeneration inhibit prevents reset regeneration from occurring.



Permanently inhibiting regeneration is not recommended, as this will eventually cause significant reduction in engine power and will force premature DPF soot filter replacement.

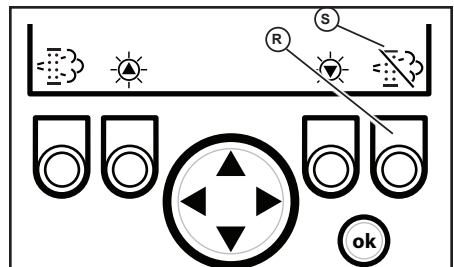

Fig. 47 - Reset Regeneration Inhibit button

To temporarily inhibit reset regeneration, hold down button (R, Fig. 47) until the strike-through in the Reset Regeneration symbol (S) turns to red.

# OPERATION

**NOTE:** DPF in-progress (elevated temperature) symbol (Q, Fig. 46) will not be displayed when reset regeneration is inhibited.

## Stationary Regeneration

Stationary regeneration may be periodically required to reduce DPF soot build-up. The frequency of stationary regeneration is dependent upon machine operation and engine load.

The machine cannot be used during stationary regeneration and cannot be moved without interrupting the stationary regeneration process.

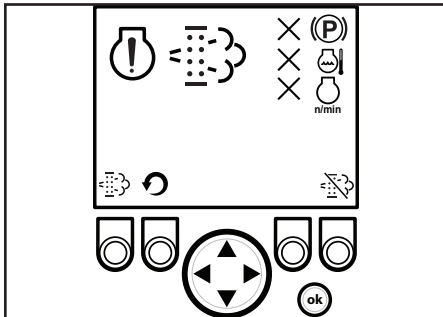

Fig. 48 - Stationary Regeneration Request Screen

When stationary regeneration needs to be performed, the regeneration request screen (Fig. 48) displays on the information center electronic display.

**NOTE:** The stationary regeneration request screen can be temporarily dismissed by pressing the reset regeneration inhibit button (R, Fig. 47) for 3 seconds. Until the previous screen displays. The stationary regeneration request screen will return 1 minute after being dismissed, for as long as the request remains active.

**IMPORTANT:** Perform stationary regeneration as soon as possible when the stationary regeneration request screen displays. Postponing stationary regeneration for extended periods will cause significant reduction in engine power

and will force premature DPF filter core replacement.

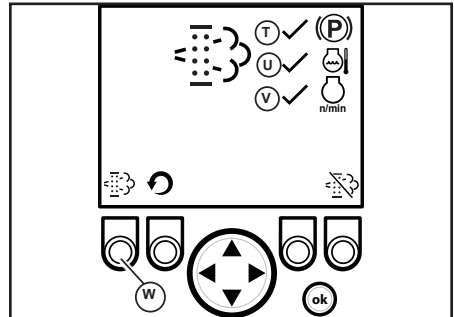
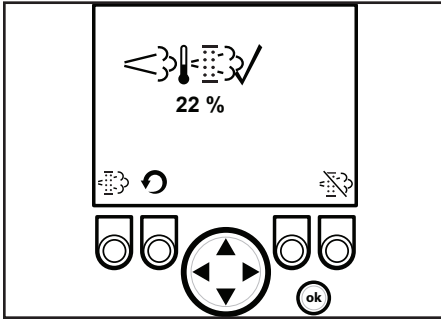

Fig. 49 - Stationary Regeneration

To proceed with stationary regeneration (Fig. 49):

1. Park the machine in a safe, well-ventilated location away from flammable materials.
2. The following conditions need to be met before stationary regeneration continues:
  - a. Press the button on the control keypad or lift the operator restraint bar to apply the parking brake. A check mark is displayed next to the parking brake symbol (T).
  - b. When engine coolant has reached operating temperature (above 140° F / 60° C, a check mark is displayed next to the coolant temperature symbol (U).
  - c. Place throttle controls to the lowest speed setting. A check mark is displayed next to the engine RPM symbol when the engine is running at low idle.



**Fig. 50 - Stationary Regeneration In-Progress Screen**

- When all three check-marks (T, U & V) are displayed on the Stationary Regeneration screen, press and hold the button (W) until the Stationary Regeneration In-Progress screen displays (Fig. 50).

**NOTE:** Stationary regeneration can be interrupted at any time by releasing the parking brake, advancing the throttle, or stopping the engine. Stationary regeneration must start again from the beginning if it is interrupted.

Stationary regeneration completion percentage is displayed as during the stationary regeneration progresses. Progress percentage disappears when stationary regeneration completes.

**NOTE:** Stationary regeneration takes approximately 25-30 minutes.

## CAUTION

It is not necessary to stay in the machine during stationary regeneration. Keep the machine under observation while regeneration is in progress in case of malfunction. Keep bystanders away from the machine while regeneration is in progress.

## Forcing Stationary Regeneration

Stationary regeneration can be performed at any time after 50 operating hours following the previous stationary regeneration.

To perform stationary regeneration on-demand:

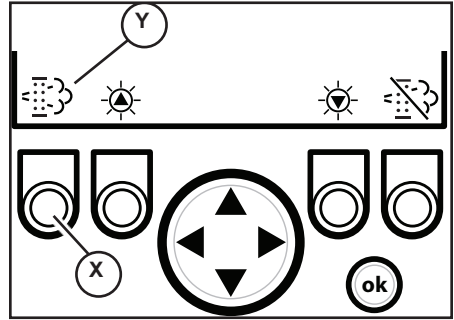
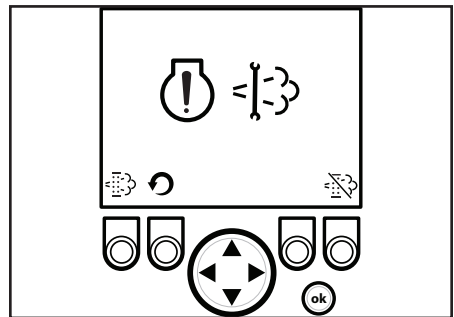

**Fig. 51 - Forcing Stationary Regeneration**

To perform stationary regeneration on-demand:

Press button (X, Figure 14) associated with the DPF regeneration symbol (Y), until the regeneration screen displays. Refer to “Stationary Regeneration” on page 92 to proceed with stationary regeneration.

## DPF Maintenance



**Fig. 52 - DPF Service Screen**

DPF soot filter replacement is required when the DPF (Diesel Particulate Filter) Service Screen (Fig. 52) displays.

**NOTE:** Contact your dealer when the DPF Service screen displays.

# OPERATION

---

## After Operation



### WARNING

**Park the machine on firm, level ground. Raise the restraint bar to disable the hydraulic controls.**

---



### WARNING

**Always apply the lift arm support if leaving the machine with the lift arm in the raised position. Refer to “Lift Arm Lift Support” on page 76.**

**If you must park on a slope or an incline, park across the slope and block the machine to prevent movement.**

---



### WARNING

**If parking on a street, use barriers, caution signs, lights, etc. to increase the visibility of the machine and prevent collisions. This is especially important at night, during bad weather and in high-traffic areas.**

---

After performing the “Mandatory Safety Shutdown Procedure” on page 16, perform the following tasks and checks:

- Fill the fuel tank. Refer to “Types of Lubricants” on page 101.
- Remove any dirt and/or debris from the engine compartment.
- Remove any mud from the chassis. Clean any dirt or water from the cylinder rod surfaces to prevent corrosion and protect the cylinder seals.
- If parking the machine for an extended period, lock the cab door, the storage compartment, the battery and hydraulic filler

compartments and the engine compartment. Take the keys with you.

## Jump-Starting

If the battery becomes discharged or does not have enough power to start the engine, use jumper cables and the following procedure to jump-start the engine.



### WARNING

**The ONLY safe method for jump-starting a discharged battery is for TWO PEOPLE to perform the following procedure. The second person removes the jumper cables so that the operator does not have to leave the operator’s compartment with the engine running. NEVER make jumper cable connections directly to the starter solenoid of either engine. DO NOT start the engine from any position other than on the operator’s seat and then ONLY after being sure ALL controls are in “neutral.”**

**Closely follow the procedure, in order, to avoid personal injury. In addition, to protect your eyes wear safety glasses and avoid leaning over the batteries while jump-starting.**

---

DO NOT jump-start the battery if it is frozen, because it may rupture or explode.

**NOTE: BE SURE the jumper battery is a 12-volt D.C. battery.**

1. Turn the keyswitches of both vehicles to OFF, be sure the vehicles are in “neutral” and NOT touching each other.
2. Connect the positive (+) jumper cable to the positive (+) battery terminal on the disabled machine first. DO NOT allow the positive clamps to touch any metal other than the positive (+) battery terminals.

3. Connect the other end of the positive jumper cable to the jumper vehicle's battery positive (+) terminal.
4. Connect the negative (-) jumper cable to the jumper vehicle's battery negative (-) terminal.
5. Make the final negative (-) jumper cable connection to the disabled machine's engine block or machine frame (ground), such as the rear grille latch post – NOT to the disabled battery's negative post. If connected to the engine, keep the jumper clamp away from the battery, fuel lines and moving parts.
6. Start the machine. If it does not start at once, start the jumper vehicle engine to avoid excessive drain on the booster battery.
7. After the disabled machine is started and running smoothly, have the second person remove the jumper cables (negative (-) jumper cable first) from the jumper vehicle's battery and then from the disabled machine while being sure NOT to short the two cables together.

Allow sufficient time for the skid-steer machine alternator to build-up a charge in the battery before attempting to operate the machine or shut the engine off.

## Lifting the Machine using a Crane



### WARNING

**Make sure the crane and the lifting gear (cables, chains) have sufficient load-bearing capacity.**

**The crane and the lifting gear must be adjusted to the proper dimensions. Always lift the machine so it is horizontal when it is raised.**

**Secure the machine against unintentional movement!**

**Keep clear of suspended loads.**

**Never lift with anyone in or on the machine.**

**Securely fasten the lifting gear to the machine at the designated lift points.**

**The crane lifting crew must include experienced crane operators only.**

**Lift the machine only with no attachments, with the exception that the standard bucket can remain attached. The bucket must be empty and set to transport position. Refer to "a. Attachment Transport Position: Carry materials 200-300 mm (8-12") above the ground, and adjust as necessary to clear obstacles. Generally, carry the load as low as safely possible. Tilt buckets back, as shown in Fig. 27, to prevent spilling material." on page 75.**

## Crane Lifting Preparation

**IMPORTANT:** *Crane handling requires lifting gear with a spreader bar with 4 ropes, chains, etc.*

**NOTE:** *If a bucket is attached, it must be empty.*

1. If a bucket is attached, make sure it is emptied. Tilt the bucket back.

# OPERATION

---

2. Lower the lift arm.
3. Turn off the engine and remove the ignition key.
4. Raise the restraint bar to disable the hydraulic controls.
5. If equipped, close and lock the cab door. Do not allow anyone to stay in the cab.
6. Close all compartment doors and the engine cover.
7. Connect spreader bar and chains to front and rear lift points. The spreader bar length should allow for the lift chains to be as vertical as possible during lifting. The lifting chain lengths should allow for lifting the machine as level as possible.



## CAUTION

**Do not fasten the lifting gear to the cab to crane lift the machine.**

---

8. Carefully raise the machine, keeping it as level as possible.

## Towing / Transporting the Machine



## WARNING

**Park the truck or trailer on a level surface. Be sure the vehicle and its ramps have the weight capacity to support the machine. Make sure the vehicle surface and its ramps are clear of debris and slippery material that may reduce traction. Move the machine on and off the vehicle ramp slowly and carefully. Failure to follow these instructions could result in an overturn accident. Towing the machine is not recommended as a means of transportation.**

---

Observe all local regulations governing the loading and transporting of equipment (Reference: U.S. Federal Motor Carrier Safety Regulations, Section 392). Ensure that the hauling vehicle meets all safety requirements before loading the skid-steer machine. Use the tie down/retrieval points in situations where lifting the machine is not possible and the overall distance by which the machine is to be moved is less than 100 feet (30.5 m) at 6 mph (10 km/hr) or less. The optional brake release package (page 48) facilitates machine retrieval in such situations. When transporting a machine:

1. Block the front and rear of the hauling vehicle's tires.
2. If the machine has an attachment, lift it slightly off the ground.
3. Back the machine slowly and carefully up the ramp onto the vehicle.
4. Lower the machine attachment to the vehicle deck, turn off the engine and remove the key.

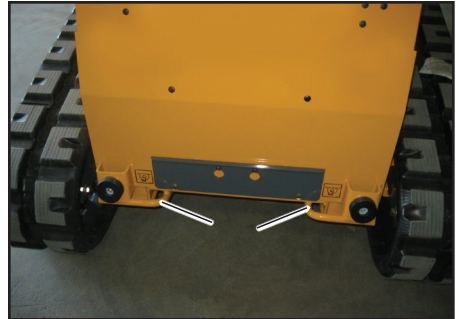

Fig. 53 - Front Tie Down / Retrieval Points





Fig. 54 - Rear Tie Down / Retrieval Points

5. Fasten the machine to the hauling vehicle at the points indicated by the tie-down decals (Fig. 53 and Fig. 54).
6. Measure the clearance height of the machine and hauling vehicle. Post the clearance height in the cab of the vehicle.

When towing a machine:

1. Connect the towline to both tie down/retrieval points at the front or the rear of the machine. Use of only a single retrieval point or connecting the towline to any point on the machine other than the designated retrieval locations could result in machine damage.
2. The towline strength is at least 1.5 times the gross weight of the machine. The towline length is such that the maximum towing angle does not exceed 20°.

## Loading and Transporting the Machine on a Transport Vehicle



### WARNING

Do not exceed the transport vehicle's gross weight rating and the gross axle weight rating when loading and transporting the machine. The transport vehicle must have sufficient capacity for the size and weight of the machine. Refer to "Specifications" on page 37.

**Make sure the load does not fall short of the minimum axle load of the steering axle, otherwise the transport vehicle's steering could be seriously affected.**

**Remove any mud, snow or ice from the tracks on the machine to prevent slipping.**

**Position the machine at the lowest possible position on the transport platform, with the center of gravity of the load over center line of the transport vehicle. Distribute partial loads to ensure an even load on the axles on the transport vehicle.**

**Secure the machine properly so it cannot slip, slide, roll, tip over or fall, or cause the transport vehicle to tip over under transport conditions. Use anti-slip bases and linings, load-securing straps and chains, clamping beams, protective pads, nets, edge protectors, etc. as needed to properly secure the load. Consider all possible transport conditions such as: heavy braking, evasive maneuvers, and uneven or rough roadways.**

**Adjust transport speed to the load, to the road/traffic conditions and to the handling of the transport vehicle**

**Always use the proper tie-down points when using straps and chains.**



# OPERATION

## Loading and Securing the Machine



Secure the loading ramps to the transport vehicle before loading. Position the loading ramps at the shallowest possible angle. Do not exceed an angle of 15°. Only use ramps with anti-skid surfaces.

Make sure the loading area is clear and access to it is not obstructed.

Make sure the driver of the transport vehicle knows the overall height, width and weight of the vehicle, including the loaded machine, before starting transport.

Know and follow the legal transport regulations for the area in which the transport will occur.

Make sure the loading ramps are free of mud, oil, grease, snow, ice, etc.

Know and follow all transport regulations for the area where the transport will occur.

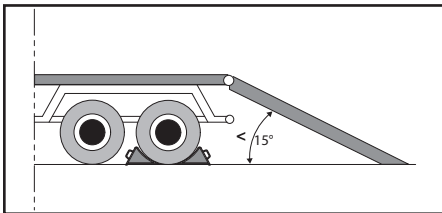

Fig. 55 - Loading Ramp Placement

1. Check the engine oil. The oil level must be at the "MAX" mark on the dipstick. Add oil if needed.

**IMPORTANT:** When loading and driving on ramps, the engine can be damaged if the engine oil level is too low.

2. Start the engine.

3. Raise the hitch plate/attachment enough so that it will not touch the loading ramps.
4. Slowly and carefully drive the machine in reverse onto the transport vehicle, with the bucket end facing down the ramp.
5. Do not adjust travel direction while traveling on the ramps. Instead, drive down off of the ramps, and re-align the machine with the ramps.
6. Position the machine at the lowest possible position on the transport platform, with the center of gravity of the load over center line of the transport vehicle.
7. Lower the bucket onto the loading area.
8. Stop the engine.
9. Raise the safety bars/armrests to disable the hydraulic controls.
10. Remove the ignition key.
11. Do not allow anyone to stay in the cab.
12. Close all doors and the engine cover.
13. Tie down the machine as follows:
  - a. Make sure the authorized maximum height is not exceeded.
  - b. Place blocks in front and behind tracks to prevent movement.
  - c. Securely strap the machine at the tie-down points (Fig. 83) to the platform. Use only belts or chains of sufficient capacity.

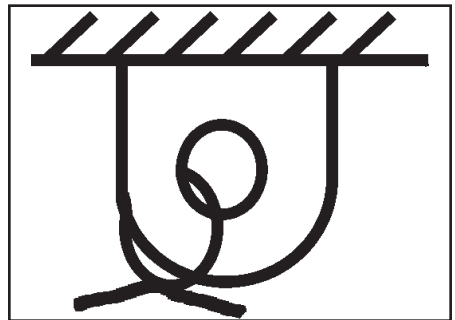

Fig. 56 - Tie-Down Point Identifier

**IMPORTANT:** Before transporting the machine through heavy rain, close off the exhaust pipe with a cap or suitable adhesive tape.

## Long-Term Storage

### Storing the Machine

If the machine is to be stored for a period in excess of two months, the following procedures are suggested:

1. Fully inflate the tires.
2. Lubricate all grease zerks.
3. Check all fluid levels and replenish as necessary. (Review and follow the engine manufacturers recommendations from the Engine Operator's Manual.)
4. Add stabilizer to the fuel per the fuel supplier's recommendations. If the fuel has a mixture of BioDiesel, empty the fuel tank before storing.
5. Turn the electrical battery disconnect switch to its "OFF" position and remove the battery, charge it fully and store in a cool, dry location.
6. Protect against extreme weather conditions such as moisture, sunlight and temperature.

### Removing Machine from Storage

1. Check the tire air pressure and inflate the tires if they are low.
2. Connect the battery and check that the electrical battery disconnect switch is turned to its "ON" position.
3. Check all fluid levels (engine oil, transmission/hydraulic oil, engine coolant and any attached implements). (Review and follow the engine manufacturers

recommendations from the Engine Operator's Manual.)

4. Start the engine. Observe all gages. If all gages are functioning properly and reading normal, move the machine outside.
5. Once outside, park the machine and let the engine idle for at least five minutes.
6. Shut the engine off and walk around machine. Make a visual inspection looking for evidence of leaks.

## Final Shutdown / Decommissioning

**IMPORTANT:** *Dispose of all materials properly. Used oils/fluids are environmental contaminants and may only be disposed of at approved collection facilities. Never drain any oils/fluids onto the ground, dispose of in municipal waste collection containers, or in metropolitan sewer systems or landfills. Check state and local regulations for other material disposal requirements.*

If the machine will no longer be used as intended, shutdown, decommission and dispose of it according to the valid regulations.

### Before Disposal

1. Shutdown the machine according to valid regulations regarding proper shutdown.
2. Park the machine on level, dry ground. Ensure the surface can support the weight of the machine. Ensure the location is protected against access by unauthorized persons.
3. Move the throttle to the low-idle position and allow the engine to cool for approximately 2 minutes.
4. Shut off the engine.
5. Move the lift/tilt control(s) to verify that the controls do not cause movement of the lift arm or hitch.

# OPERATION

---

6. Raise the restraint bar to disable the hydraulic controls.
7. Switch off all electrical switches.
8. Unfasten the seat belt, remove the ignition key and take it with you.
9. Ensure the machine cannot be operated after shutdown until further disposal.
10. Ensure no environmentally hazardous materials, fluids and/or fuel can escape the machine. Specifically check for leaks from the engine, the hydraulic system and the coolant system.
11. Ensure the machine poses no dangers in the place where it is standing.
12. Remove any dirt and/or debris from the engine compartment, the chassis and the cylinder rod surfaces.
13. Remove the battery.
14. Lock the cab door, the storage compartment, the battery and hydraulic filler compartments and the engine compartment. Remove the key(s) and take it/them with you.

## ***Machine Disposal***

Make sure all materials are disposed of in an ecologically sound manner.

Recycle the machine in accordance with the current state of the art at the time of recycling. Observe all accident prevention regulations.

Dispose of all parts at the recycling sites specific to the material of the part. Take care to separate different materials for recycling.

# Chapter 7

## LUBRICATION

### Types of Lubricants

**IMPORTANT:** Use of lubricants not corresponding to manufacturer recommendations may invalidate warranty claims. Always dispose of waste lubrication oils and hydraulic fluids according to environmental laws or take to a recycling center for proper disposal. **DO NOT** pour fluids onto the ground or down a drain.

### Lubricant Capacities

Listed below are the locations, temperature ranges and types of recommended lubricants to be used when servicing this machine. Refer to the separate engine manual for more information regarding recommended engine lubricants, quantities required and grades.

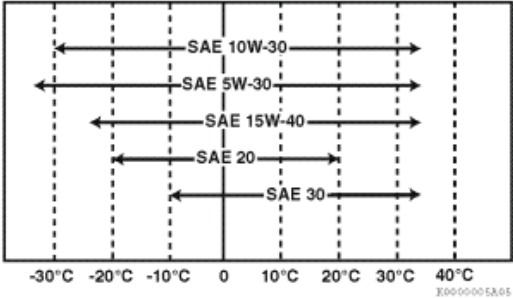
System Type	Type and Amount of Lubricant
Hydraulic	<p>Use Petro Canada HVI60, Mobil DTE 15M or equivalent, which contain anti-rust, anti-foam and anti-oxidation additives, and conforms to ISO VG46.</p> <p>Capacity: 30.0 L (8 U.S. gallons)</p>
Grease Fittings	Use lithium based grease
Engine Oil	<p>Conventional oils - select the oil viscosity based on the ambient temperature where the engine is being operated. See SAE viscosity chart. Full Synthetic Oil 0W-40. Do not mix oil types.</p> <p>Capacity: (5.87 L) 6.2 U.S. quarts</p>  <p style="text-align: right;"><small>30000005805</small></p>
Anti-Freeze Coolant	<p>Add a mixture of 50% water, 50% ethylene glycol to the recovery tank if coolant level in recovery tank is low.</p> <p>Entire System Capacity: 6.62 L (1.75 U.S. gallons)</p>

# Lubrication

---

## Lubrication Points

Wipe dirt from the fittings before and after applying grease to prevent contamination. Replace any missing or damaged fittings. Avoid excessive greasing to minimize dirt build-up.



Fig. 57 - Grease Fitting On Hitch Pin

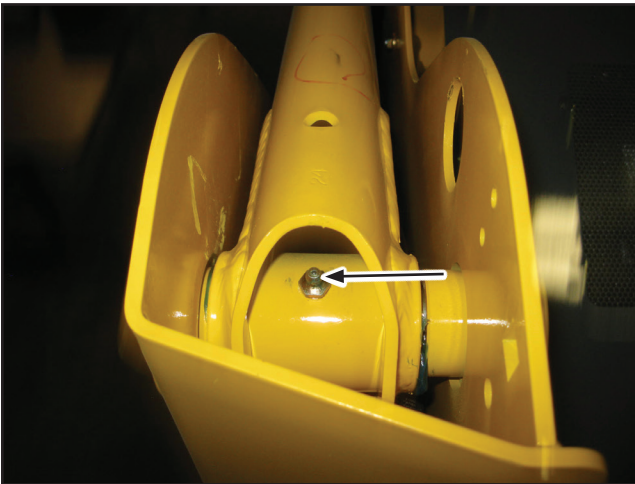

Fig. 58 - Grease Fitting on Lift Arm Pivot

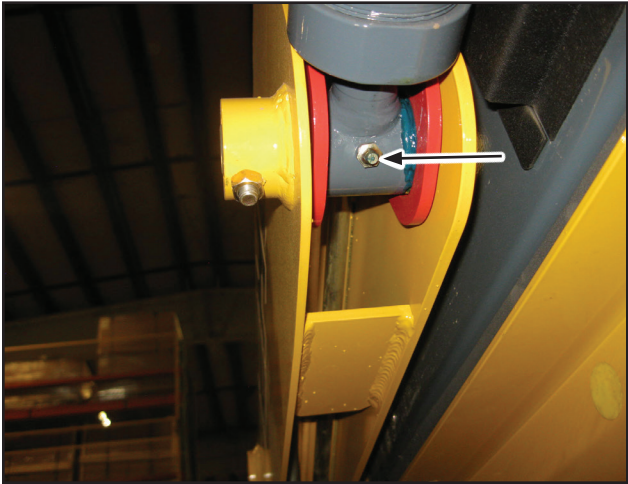

Fig. 59 - Grease Fittings on Lift Cylinder Rod End

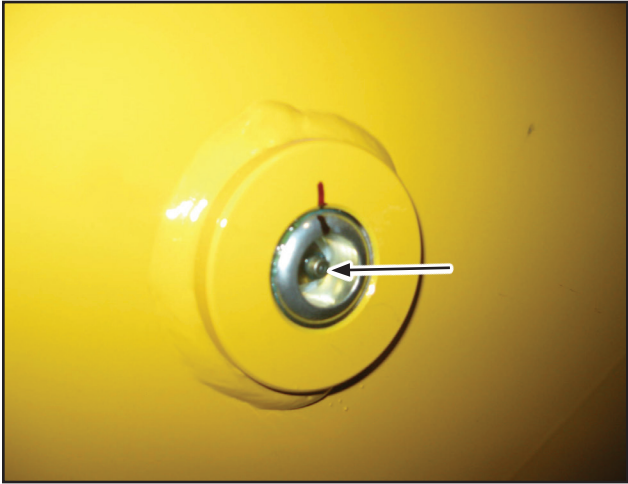

Fig. 60 - Grease Fitting on Lift Cylinder Base End

# Lubrication

## Lubrication Schedule/Intervals

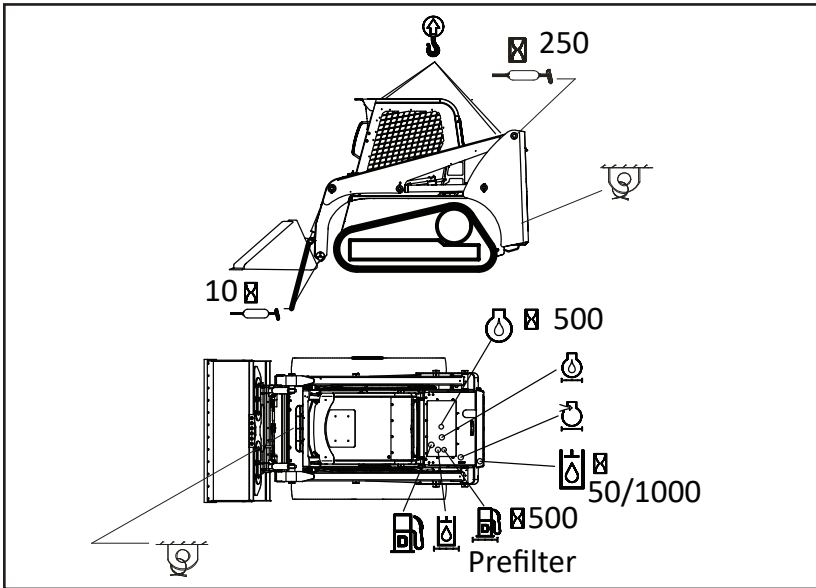

Fig. 61 - Lubricating Service Locations

Lubrication Procedure	10 Hours (or Daily)	50 Hours	250 Hours	1000 Hours (or Annually)
Check Engine Oil Level	X			
Check Hydraulic Oil Level	X			
Grease Hitch, Hitch-related Cylinder Pivots and Latch Pins	X			
Grease Lift Arm Pins	X		X	
Change Engine Oil				X (500 hours)
Change travel motor gear oil				X*
Change Hydraulic Oil				X
Check and Drain Water Separator		X		
Change Coolant				X

\* Change travel motor gear oil every 2000 hours or with any drive motor repair.

**Filter Table**

<i>Service Procedure</i>	<i>Maximum Interval</i>			
	<i>10 Hours (or Daily)</i>	<i>50 Hours (or every week)</i>	<i>250 Hours (or every 6 months)</i>	<i>500 Hours (or Annually)</i>
<i>Change hydraulic oil filter</i>				X
<i>Change engine oil filter</i>				X
<i>Change cab air filter, if applicable</i>			X	
<i>Change outer air cleaner filter element. Check and change inner air cleaner element if necessary</i>			X	
<i>Replace Filter in Water Separator</i>				X
<i>Change Main Fuel Filter</i>				X <sup>1</sup>
<i>Change Water Separator Filter</i>				X

1. Non-DPF machines require a 250 hour main fuel filter change.





# Chapter 8

## MAINTENANCE

### Maintenance Schedule

This Maintenance Interval Chart was developed to match the Service chapter of this manual. Detailed information on each service procedure can be found in the Service chapter. A Maintenance Log follows the chart for recording the maintenance performed. Recording the 10-hour (or daily) service

intervals would be impractical and is therefore not recommended.

**IMPORTANT:** *Under severe operating conditions, more frequent service than the recommended intervals may be required. You must decide, based on your use, if your operation requires more frequent service.*

### Maintenance Interval

<b>Service Procedure</b>	<b>Maximum Interval</b>		
	<b>10 Hours (or Daily)</b>	<b>250 Hours</b>	<b>500 Hours (or Yearly)</b>
Remove foreign material	X		
Check engine air cleaner restriction indicator	X		
Check for loose or missing parts; repair/replace if necessary.	X		
Check engine oil level and condition	X		
Check fuel level and fill if necessary.			
Check hydraulic oil level and condition	X		
Check coolant level and condition	X		
Check cooling system system for dirt and debris	X		
Check water separator, drain water, if present.	X		
Check windshield washer system and wiper blade, if applicable.	X		
Inspect tracks for damage/wear.	X		
Check bucket cutting edge.	X		
Test safety interlock system.	X		
Check hydraulic cylinder piston rods for damage/wear, clean if necessary.	X		
Check ROPS/FOPS structure - all fasteners must be installed and tightly secured.	X		
Check hydraulic hoses and tubes for cracks and/or debris.	X		
Grease hitch, hitch-related cylinder pivots and latch pins.	X		
Grease lift arm pins.	X		
Check sprocket fastener torque.	X		X
Inspect for sprocket wear.		X	
Check alternator/fan belt tension and condition.		X	
Check battery.			X
Check engine mounting hardware.			X

# MAINTENANCE

**Table 16 - Leakage Test**

Service Procedure	Maximum Interval		
	10 Hours (or Daily)	250 Hours	500 Hours (or Yearly)
Check engine for oil/coolant leaks.	X		
Check cooling system for leaks.	X		
Check hydraulic system for leaks.	X		

**Table 17 - Lubrication and Filter Changes**

Service Procedure	Maximum Interval		
	10 Hours (or Daily)	250 Hours	1000 Hours (or Yearly)
Lubricate grease fittings.	X		
Change hydraulic oil filter.			X <sup>1</sup>
Change engine oil and filter.			X
Change cab air filter, if applicable.			X <sup>2</sup>
Lubricate all levers, cables and hinges.		X	
Change outer air cleaner filter element. Check and change inner air cleaner element.		X	
Change hydraulic reservoir oil.			X
Drive motor front case oil.			X <sup>3</sup>
Change fuel filter.		X <sup>4</sup>	
Change coolant.			X

1. After every 500 hours.
2. Replace if needed.
3. Change every 2000 hours or yearly.
4. Non-DPF machines require a 250 hour fuel filter change interval. DPF machines require a 500 hour fuel filter change interval.

**Table 18 - Functional Check**

Service Procedure	Maximum Interval		
	10 Hours (or Daily)	250 Hours	500 Hours (or Yearly)
Check seat belt.	X		
Check service and parking brake function.	X		
Check joystick operation.	X		
Check windshield wipers, if applicable.	X		
Check control switches/buttons, indicators and audible warning devices.	X		
Check lighting systems.	X		

## Engine Maintenance

### Check Engine Mounting Hardware

All bolts that secure the engine mounting brackets to the engine and the loader frame should be checked and re-tightened as necessary.



**Allow hot engine and hydraulic system components to cool before servicing.**

### Checking Engine Oil Level

Check the engine oil level daily before starting the machine, or after every ten hours of use.

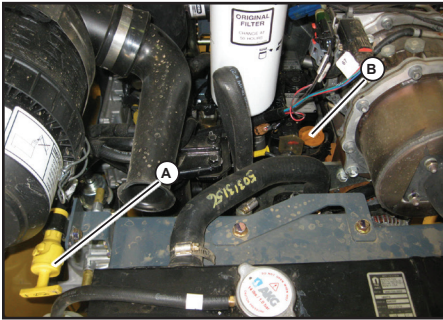

**Fig. 62 - Oil Dipstick and Fill Cap**

1. Park the machine on a level surface.
2. Perform the “Mandatory Safety Shutdown Procedure” on page 27.
3. Wait until the engine has cooled. Refer to “Maintenance and Service Safety Practices” on page 22.
4. Open the rear door and engine access cover.
5. Pull out the dipstick (A, Fig. 62) and check the oil level. The oil fill cap (B, Fig. 62) is located nearby.

6. Wipe the dipstick with a clean cloth and replace it in the engine. Push it in until it is fully inserted.
7. Remove the dipstick again. The oil level should be within the “Add” and “Full” markings.
8. Markings on the dipstick represent full and low (add oil) levels. Refer to the Maintenance Interval Chart (page 107) for the service interval for replacing the engine oil and filter.

**IMPORTANT:** *Do not over-fill the engine with oil. Damage could result.*

### Changing Engine Oil and Filter

Change the engine oil and filter every 500 hours. Refer to “Fuel System Maintenance” on page 112 for proper grade and type.

**IMPORTANT:** *Oil should be changed more frequently under heavy work conditions, if higher sulfur content fuel is used, or if multiple standstill regenerations are performed.*

*Reduce the oil change interval if the machine is exposed to constant ambient temperatures below -10 °C (14 °F).*

1. Park the machine on a level surface.



**Fig. 63 - Rear Belly Pan Opening.**

2. Run the engine until it is at operating temperature. Stop the engine. Remove the rear belly pan (C, Fig. 63).

# MAINTENANCE

3. Perform the “Mandatory Safety Shutdown Procedure” on page 16.
4. Wait until the engine has cooled, but is not completely cold. Oil will drain faster and more completely if it is warm.
5. Position a waste oil collection container under engine oil drain plug to catch draining oil
6. Remove the engine oil drain plug.

**IMPORTANT:** *Dispose waste engine oil according to environmental laws, or take to a recycling center for proper disposal. DO NOT pour waste engine oil onto the ground or down a drain.*

7. Remove drain plug from the engine oil pan and allow the oil to drain into the waste oil collection container.
8. From the engine compartment, remove the oil filter. Clean the filter sealing surface.
9. Put clean oil on the new oil filter gasket. Install the filter and tighten 3/4 of a turn past the point where the gasket contacts the filter head.
10. Reinstall and tighten the drain plug to 55 Nm (40.5 lbs-ft.).
11. Remove the oil cap and add the recommended oil. Refer to “Fuel System Maintenance” on page 112 .
12. Start the engine and let it run for several minutes at low idle. Stop the engine. Check for leaks at the oil filter, drain plug and remote oil drain hose. Check the oil level. Add oil if it is not at the top mark on the dipstick.

**NOTE:** *Oil capacity listed is approximate. Always verify proper oil level with the engine oil dipstick.*

## Changing Fuel Filter



### WARNING

**NEVER** service the fuel system while smoking, while near an open flame, or after the engine has been operated and is hot.

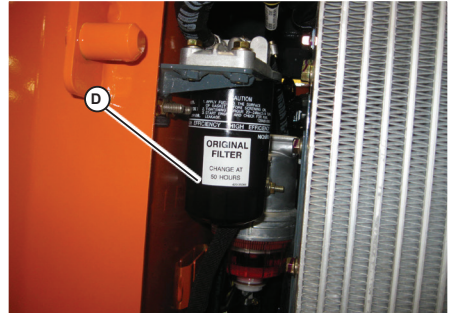

**Fig. 64 - Engine Fuel Filter**

The engine has a fuel filter (D, Fig. 64) located on the left side of the engine. To change it:

1. Shut off the fuel supply by turning the fuel shutoff valve on top of the water trap.
2. Remove the fuel filter element.
3. Lubricate new fuel filter element gasket with diesel fuel.
4. Install and tighten the filter element one-half turn past point the where the gasket contacts the filter head.
5. Turn shutoff valve on water separator to ON.
6. Prime the fuel system by turning the ignition key to the ON position without starting the engine for 30 seconds.

## CAUTION

Do not use the starter motor to crank the engine to prime the fuel system. Damage to the engine starter motor, coils, pinion/ring gear could result.

### Engine Air Filters

**IMPORTANT:** Do not operate the engine without the air cleaner components installed or damage to the engine could occur.

The air cleaner consists of an outer (primary) filter element and an inner (secondary) filter element. An air filter restriction indicator for monitoring the condition of the elements is located on the right side of the front of the air cleaner. If the air filter becomes restricted, this indicator will turn red to warn the operator that the element(s) require service. Push the reset button located on the end of the indicator after fitting a clean element.

**NOTE:** Before replacing the filter element(s), push the reset button on the indicator. Start the engine and adjust the throttle to full speed. If the indicator does not turn red, do not replace the element(s).

The outer element should be replaced only when the restriction indicator turns red. The inner element should be replaced every third time the outer element is replaced, unless the outer element is damaged or the inner element is dirty.

Along with a daily check of the restriction indicator, check the air cleaner intake hose and clamps, and the mounting bracket hardware to be sure they are properly tightened.

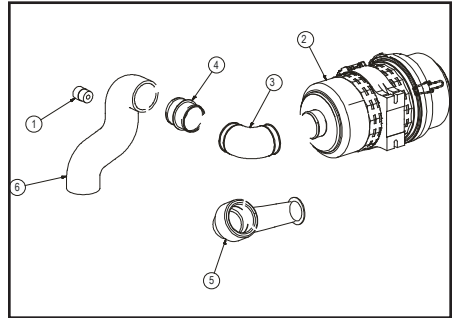

Fig. 65 - Dual Element Air Cleaner

1. Restriction Indicator
2. Element Housing
3. Elbow Hose
4. Hose Connector
5. Sound Diffuser/Intake Suppressor
6. Air Intake Tube

### Access

1. Open the rear door and engine access cover.
2. Unlatch the clamps on the air cleaner and remove the cover. Clean out any dirt built up in the cover assembly.

### Outer Element

1. Carefully pull the outer element out of the housing. Never remove the inner element unless it is to be replaced.
2. Clean out any dirt built up in the housing. Leave the inner element installed during this step to prevent debris from entering the engine intake manifold.
3. Replace the outer element.

**NOTE:** Manitou Group does not recommend cleaning the outer element.

4. Use a trouble light inside the outer element to inspect for spots, pinholes or ruptures. Replace the outer element if any damage is noted. The outer element must be replaced if it is oil- or soot-laden.

# MAINTENANCE

## Inner Element

**NOTE:** Replace the inner element only if it is dirty or if the outer element has been replaced three times.

1. Before removing the inner element from the housing, clean out any dirt built up in the housing. Leave the inner element installed during this step to prevent debris from entering the engine intake manifold.
2. Remove the inner element.

## Re-installation

1. Check the inside of the housing for any damage that may interfere with the elements.
2. Be sure that the element sealing surfaces are clean.
3. Insert the element(s), making sure that they are seated properly.
4. Secure the cover to the housing with clamps.
5. Check the hose connections and be sure they are all clamped and tightened properly.
6. Reset the restriction indicator by pressing the reset button.

## DPF Exhaust System Service

DPF soot filter replacement is required when the DPF Service screen (Fig. 66) is shown on the multi-purpose display.

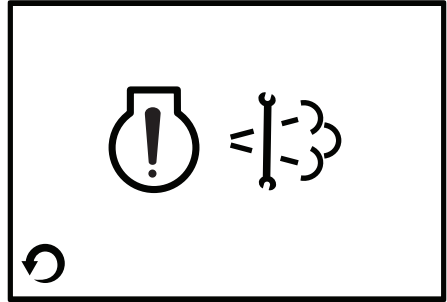

Fig. 66 - DPF Service Screen

**NOTE:** DPF service should be performed only by an authorized dealer.

## Fuel System Maintenance

### **WARNING**

Diesel fuel is flammable. Keep the machine away from open flames. Do not smoke when refueling or when working on the engine. Stop the engine before fueling.

Wear eye protection. The fuel system is under pressure and fuel could spray out when removing any fuel system component.

Wipe up spills immediately. NEVER use a shop rag to catch draining/leaking fuel. Vapors from the rag are flammable and explosive.

Failure to follow these instructions can cause fire and result in injury or death.

### **CAUTION**

Use only proper types and grades of diesel fuel. Refer to “Check engine oil level and condition” on page 107.

**NOTE:** The fuel tank is filled at the factory with United States off-road grade

diesel fuel, which is dyed red for identification. It may take several fillings of the fuel tank before the red dye is purged from the fuel system.

**IMPORTANT:** Service the fuel system only in an absolutely clean environment to avoid contamination.

## Adding Fuel

### **WARNING**

Static electricity can produce dangerous sparks at the fuel-filling nozzle. Do not wear polyester, or polyester-blend clothing while fueling. Before fueling, touch the metal surface of the machine away from the fuel fill to dissipate any built-up static electricity. Do not re-enter the machine but stay near the fuel filling point during refueling to minimize the buildup of static electricity. Do not use cell phones while fueling. Make sure the static line is connected from the machine to the fuel truck before fueling begins.

Ultra-Low Sulfur Diesel (ULSD) poses a greater static ignition hazard than earlier diesel formulations. Avoid death or serious injury from fire or explosion; consult with your fuel or fuel system supplier to ensure the entire fuel delivery system is in compliance with fueling standards for proper grounding and bonding practices.

Though not necessary to leave locked, the use of a locking fuel cap protects the loader from fuel theft or fuel system vandalism. The key to this lockable fuel cap should be secured to the loader's key ring. A torque override features aids in the proper installation of the fuel cap. It produces an audible click as the o-ring that seals the cap is properly compressed. To operate the lockable fuel cap:

1. Perform the "Mandatory Safety Shutdown Procedure" on page 16.
2. Unlock fuel cap (E, Fig. 67) using the ignition key and remove the fuel cap from the fuel filler neck.

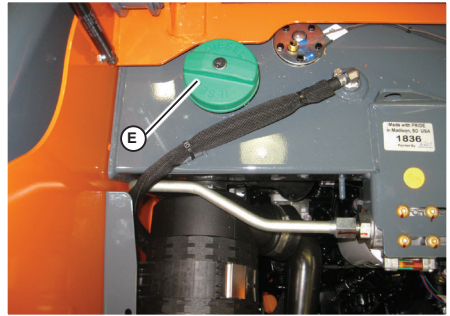

Fig. 67 - Fuel Filler Cap

3. Inspect the wire-mesh fuel strainer located in the filler neck opening and remove any accumulated residue. Replace the strainer if damaged.
4. Fill the fuel tank by adding fuel through the fuel filler neck opening.

**IMPORTANT:** Refer to "Check engine oil level and condition" on page 107 and the engine operation manual for proper fuels. Use of improper fuels can cause engine damage.

5. When the fuel tank is full, replace and lock fuel cap (E) in the fuel filler neck opening.

## Water Separator Inspection/ Maintenance

### **WARNING**

**NEVER** service the fuel system while smoking, while near an open flame, or after the engine has been operated and is hot.



# MAINTENANCE

Inspect the water separator daily, or every day before use. The water separator is located between the fuel tank and the main fuel filter and is used to remove finely dispersed water in diesel fuel. Water can be drained from the separator by opening the valve located at the bottom of the separator bowl.

**IMPORTANT:** *Water in the fuel system can cause severe engine damage. Drain water from the water separator anytime water is present.*

The water separator contains an indicator ring (F, Fig. 68) indicating the presence of water in the fuel system

1. Perform the “Mandatory Safety Shutdown Procedure” on page 16.
2. Wait until the engine has cooled.
3. Open the engine cover.

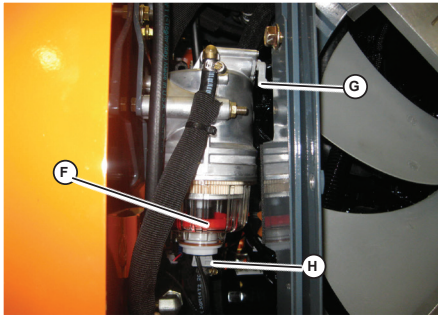

Fig. 68 - Water Separator

4. Inspect the water separator for the presence of water:
  - If the indicator ring (F) is at the bottom of the cup, no action is required.
  - If the indicator ring (F) is floating off the bottom of the cup, water is present and needs to be drained.
5. Drain water from the water separator:
  - a. If water needs to be drained, position a suitable collection container underneath the water separator drain.

- b. Turn the fuel shut-off valve lever (G) on the water separator to the OFF position.
  - c. Loosen drain plug (H) at the bottom of the water separator. Allow water to drain until indicator ring falls to the bottom of the cup.
6. Prime the fuel system by turning the ignition key to the ON position without starting the engine for 30 seconds.



## CAUTION

**Do not use the starter motor to crank the engine to prime the fuel system. Damage to the engine starter motor, coils, pinion/ring gear could result.**

**IMPORTANT:** *Dispose waste fuel according to environmental laws. DO NOT pour fuel onto the ground or down a drain.*

## Hydraulic System Maintenance



## WARNING

**Never use your hands to search for hydraulic fluid leaks; use a piece of paper or cardboard to find leaks. Escaping fluid under pressure can be invisible and can penetrate the skin, causing serious injury. If any fluid is injected into your skin, see a doctor at once. Injected fluid MUST be surgically removed, or gangrene may result.**

## Checking Hydraulic Oil Level

The machine has a dipstick (I, Fig. 69) located in the engine compartment. Check the fluid level with the lift arm lowered and the attachment on the ground.

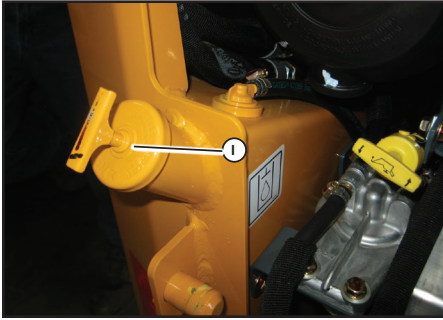
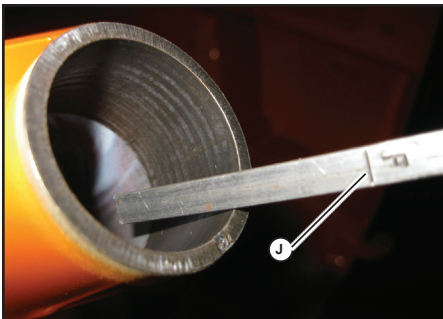

**Fig. 69 - Hydraulic Oil Dipstick and Fill Neck**

When hydraulic fluid is required, allow the system to cool. Slowly remove the oil fill cap, allowing the pressure to dispel before removing the cap completely.

Check the hydraulic oil level daily before starting the machine, or after every ten hours of use.

1. Park the machine on a level surface. Fully retract all hydraulic cylinders (lift arm down; bucket flat).
2. Perform the “Mandatory Safety Shutdown Procedure” on page 16.
3. Wait until the engine has cooled.
4. Open the engine cover and unscrew the dipstick from the fill neck.



**Fig. 70 - Hydraulic Oil Level FULL Mark on the Dipstick**

5. Check the level of the hydraulic oil on the dipstick (J, Fig. 70)

6. Add hydraulic fluid as required. Replace the cap.

## Changing Hydraulic Oil and Filter

**NOTE:** *The hydraulic oil filter can be changed without changing the hydraulic oil or draining the hydraulic reservoir.*

Change the hydraulic oil filter after 500 hours or 1 year of use thereafter.

Change the hydraulic oil if it becomes contaminated, after major repairs, and/or after 500 hours or 1 year of use.

1. Perform the “Mandatory Safety Shutdown Procedure” on page 18.
2. Wait until the engine has cooled. Refer to “Maintenance and Service Safety Practices” on page 23.
3. Open the engine cover.
4. Position a waste oil collection container with a capacity of at least 30 L (8 gals.) underneath the hydraulic oil reservoir drain plug (K, Fig. 71).



**Fig. 71 - Hydraulic Oil Drain Plug**

**NOTE:** *The hydraulic reservoir drain plug is accessed from underneath the machine at the bottom left of the hydraulic oil reservoir.*

5. Remove the hydraulic reservoir drain plug and allow the oil to drain completely.

# MAINTENANCE

**IMPORTANT:** Always dispose of hydraulic fluids according to environmental laws or take to a recycling center for proper disposal. DO NOT pour onto the ground or down a drain.

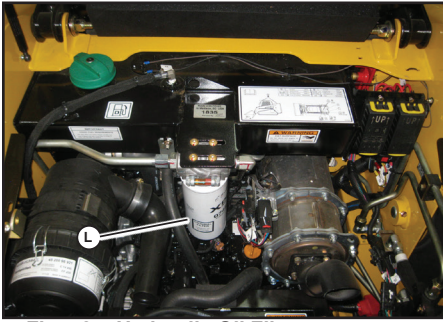

Fig. 72 - Hydraulic Oil Filter

- Remove the hydraulic oil filter (L, Fig. 72), using a filter wrench if necessary. Carefully clean the filter head mounting surface with a clean cloth.
- Apply a coating of clean oil on the new oil filter gasket. Install the filter and tighten 3/4 rotation past the point where the gasket contacts the filter head.
- Re-install and tighten the drain plug.
- Remove hydraulic dipstick/oil fill cap (I, Fig. 69) and add hydraulic oil until the level reaches the FULL marking (J, Fig. 70) on the dipstick.
- Replace and tighten the hydraulic oil fill cap. Close and lock the hydraulic tank cover. Close the engine compartment.

**NOTE:** Refer to “Fuel System Maintenance” on page 112 for proper hydraulic oil grade and type. Hydraulic oil capacity listed is approximate.

- Start the machine. Cycle through all hydraulic functions several times to purge air from the hydraulic system. Shut down the machine.
- Check the machine for hydraulic oil leaks. Correct any leaks as required.

- Add oil to the hydraulic system as required until the level reaches the FULL marking on the dipstick. Replace and tighten the hydraulic oil dipstick/fill cap.

## Engine Cooling System

**IMPORTANT:** Check the cooling system every day to prevent overheating, loss of performance or engine damage.

### Checking Coolant Level

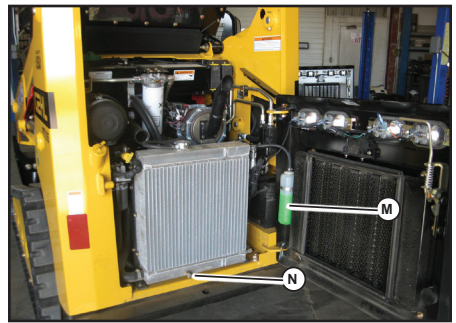

Fig. 73 - Cooling System

- Open the rear door. Check the coolant level in the coolant recovery tank (M, Fig. 73) on the inside of the rear door. The coolant recovery tank must be 1/3 to 1/2 full with a cold engine and 2/3 to 3/4 full with a hot engine.
- Allow the coolant to cool. Do not remove the cap when the coolant is hot. Serious burns may occur.
- Add premixed coolant, 50% water and 50% ethylene glycol, and supplemental coolant additives (SCAs) to the recovery tank if the coolant level is low.

### Cleaning Cooling System

- Park the loader on a level surface.
- Perform the “Mandatory Safety Shutdown Procedure” on page 16.
- Wait until the engine has cooled.

4. Open the rear door. Lift the engine cover.
5. Clean the radiator and oil cooler by blowing through the fins with high pressure water or air.
8. Fill the radiator fully and the recovery tank half full with the premixed coolant.
9. Reinstall the radiator cap.
10. Run the engine until it is at operating temperature. Stop the engine and let it cool. Check the coolant level. Add more coolant if required.

**NOTE:** *The radiator can be tipped out for cleaning by loosening and rotating the over-center links on each side. This will also help in cleaning the oil cooler.*

## **Draining/Flushing Cooling System**

1. Park the loader on a level surface.
2. Perform the “Mandatory Safety Shutdown Procedure” on page 16.
3. Wait until the engine has cooled.
4. Open the rear door. Lift the engine cover.
5. Slowly remove the radiator cap, allowing pressure to dispel before removing completely.



## **WARNING**

**Liquid cooling systems build up pressure as the engine becomes hot. Before removing the radiator cap, stop the engine and let the system cool. Remove the radiator cap only after the coolant has cooled. Remove the cap slowly or severe burns may result.**

---

6. Remove the drain plug (N, Fig. 73) and drain the coolant into a suitable container with a minimum capacity of 6,62 L (7 U.S. qts.) underneath the radiator.
7. Replace the drain plug.

**NOTE:** *Protect the cooling system by adding premixed 50% water and 50% ethylene glycol and supplemental coolant additives (SCAs) to the system. This mixture will protect the cooling system to -34°F (-36°C).*

## **Alternator/Fan Belt**

Refer to the separate engine manual for setting proper belt tension. If the belt is worn, cracked or otherwise deteriorated, replace the belt by following the procedure in the separate engine manual.

# MAINTENANCE

## Hydraulic Hose Maintenance

### WARNING

Hydraulic hoses and connections must be inspected by a trained technician before the first use of the machine, and at least annually thereafter, for leaks and/or damage.

Leaking and/or damaged pressure hose/lines must be immediately repaired or replaced by an authorized service center.

Never use your hands to check for suspected hydraulic leaks. Always use a piece of wood or cardboard.

Leaks from hydraulic hoses or pressurized components can be difficult to see, but pressurized oil can have enough force to pierce the skin and cause serious injury.

Obtain immediate medical attention if pressurized oil pierces the skin. Failure to obtain prompt medical assistance could result in gangrene or other serious damage to tissue.

Always relieve hydraulic system pressure before performing any maintenance on the machine. Do not tighten leaking connections when the hydraulic system is under pressure.

### WARNING

Never weld or solder damaged or leaking pressure tubes and/or screw connections. Always replace damaged hydraulic components.

Hydraulic hoses must be replaced every six years from the date of manufacture, even if they do not appear damaged. The date of manufacture (month or quarter and year) is indicated on hydraulic hoses. Refer to Fig. 74.

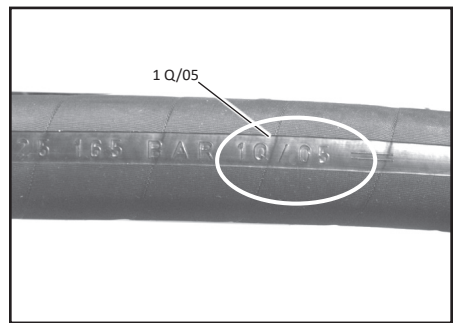

Fig. 74 - Hydraulic Hose Manufacture Date

## Travel Motor Maintenance

### *Travel Motor Front Case Oil*

Replace the travel motor front case oil every 2000 hours/annually or if it becomes contaminated after major repairs.

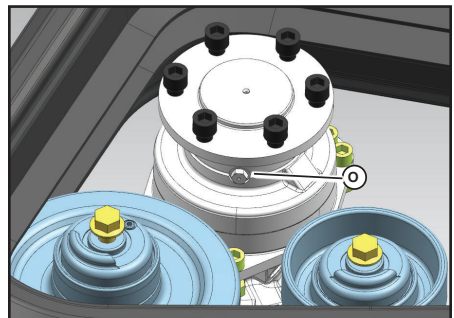

Fig. 75 - Lower Travel Motor Oil Plug

1. Park the machine with one of the travel motor drain/fill hole plugs (O, Fig. 75) at the bottom.
2. Perform the “Mandatory Safety Shutdown Procedure” on page 16.
3. Position a waste oil collection container with a 1 quart/liter (+ 0.10 quarts/liters) underneath the drain/fill hole plug and remove the lower plug.

**IMPORTANT:** *Always dispose of hydraulic fluids according to environmental laws or take to a recycling center for proper disposal. DO NOT pour onto the ground or down a drain.*

4. Remove a second plug near the top.
5. Remove the drain/fill hole plug and allow the oil to drain completely.
6. Reinstall the lower drain/fill hole plug. Tighten securely.
7. Through the top drain/fill plug, fill the travel motor front case with the same grade and type oil used in the hydraulic system. Each travel motor requires 345 - 375 ml (0.36 - 0.39 qt.) of hydraulic oil.
8. Reinstall the upper drain/fill hole plug. Tighten securely.
9. Test the drive system and check for leaks.

- Avoid traveling or turning on broken stone, jagged rock, metal or other material that could damage or cut the tracks.
- Avoid traveling on riverbeds or areas with soft rocks that could become stuck in the tracks, which could cause damage to the tracks or cause the tracks to slip off.
- Avoid using the machine on the seashore. Sea salt can corrode the metal cores inside the tracks.
- Immediately wipe any spilled fuel, oil, salt or chemical solvents off of the tracks, as these substances can corrode the coupling in the metal cores in the tracks, causing corrosion and peeling.

Avoid traveling on freshly paved roads or on hot surfaces (e.g. fires, metal sheets exposed to direct sunlight, etc.). Hot surfaces can damage the lugs or cause irregular wear.

Avoid moving earth in area where the tracks may slip, which can cause excessive lug wear.

## Track Replacement

**WARNING**

**Keeps hands clear from between the track and the idler when installing tracks. Crushing of body parts and amputation can result.**

## Tracks

### Track Maintenance

Inspect the tracks daily for damage and wear.

**IMPORTANT:** *To avoid damaging the tracks and to ensure maximum track life, refer to “Rubber Track Use Cautions and Tips” on page 72.*

Observe the following conditions to extend track life:

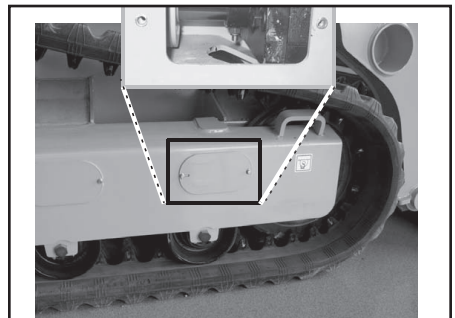

Fig. 76 - Tension Stop Cylinder



# MAINTENANCE

1. With the machine running and the drive system not moving, remove tension cylinder stop (K, Fig. 76) on the side on the machine with the track to be replaced.

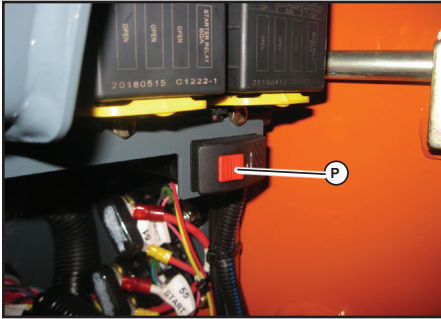

Fig. 77 - Track Tension Switch

2. With the machine running and the drive system not moving, open the engine compartment. Press and hold the red lock button (P, Fig. 77) on the track tension service switch, press the switch to set the track tension cylinders into the service (retracted) position.
3. When the track tension cylinders are in the service (retracted) position, shut off the machine.
4. Raise the machine about 150 mm (6.0") so the tracks are free to move.

## WARNING

**Use solid support blocking. Never rely on jacks or other inadequate supports when maintenance work is being done. Never work under any equipment supported only by jacks.**

5. Use a pry bar to pry/guide the old track at off the front idler wheel.
6. Using a hoist with a hook installed and a pry bar, lift/guide the old track off at the drive sprocket. Remove the old track.
7. Using a hoist with a hook, lift the new track and maneuver the track under the

rear idler wheel at using a pry bar and your foot.

**IMPORTANT:** *Guides on the inside of the track must straddle the rear idler.*

8. Place a block under the new track to hold the track against the bottom of the rear idler wheel.
9. Using a hoist with a hook and a pry bar, lift/ guide the new track onto the drive sprocket.

**IMPORTANT:** *Lugs on the inside of the track must be fully engaged by drive sprocket.*

Using a pry bar and wedging blocks, pull/ guide the new track over the front idler wheel and under the bottom rollers. Carefully, direct an assistant to start the machine and direct the assistant to operate the track drive slowly forward/back to work the track over the front idler wheel.

## WARNING

**Keeps hands and feet clear from between the track and the idler/ roller wheels when installing tracks. Crushing of body parts and amputation can result.**

**NOTE:** *The tie-down bracket can be used as a lever point for prying the track into place over the front idler wheel.*

**IMPORTANT:** *Guides on the inside of the track must straddle the front idler and bottom roller wheels.*

10. Be sure the new track is fully engaged around the idler and roller wheels, and in the drive sprocket, all the way around.
11. Remove any wedging blocks that were used to guide the track.
12. Remove the block placed under the track.

13. Start the machine, open the engine compartment and press the track tension service switch (P, Fig. 77), to set the track tension cylinders into the operating (extended) position.
14. Once the track tension cylinder has returned to the operating (extended) position, re-install cylinder stop (K, Fig. 76).
15. Operate the track drive forward/back to ensure the track is properly seated. Adjust track positioning, if necessary.
16. Remove the blocking and lower the machine to the ground.

## Electrical System



Inspect and check the machine's electrical equipment at regular intervals. Defects, such as loose connections or scorched cables must be repaired before using the machine.

Only use proper, original equipment fuses with the specified current rating. Turn off the machine immediately if there are any problems with the electrical system.

Work on the machine's electrical system must be done only by a trained technician.

## Battery



Before servicing the battery or electrical system, disconnect the negative cable from the negative battery terminal, or if the machine is equipped with a battery disconnect switch, turn the switch to the "OFF" position.

Explosive gas is produced while a battery is in use or being charged. Keep flames or sparks away from the battery area. ALWAYS charge the battery in a well-ventilated area.

Do not jump-start a frozen battery, or it may explode. A discharged battery can freeze at 0°C (32°F).

To prevent short circuits keep metal parts on your clothing and metal watchbands away from the positive (+) terminal of the battery.



# MAINTENANCE

## WARNING

Never lay a metal object on top of a battery, because a short circuit can result. Battery acid is harmful to skin and fabrics. If acid spills, follow these first-aid tips:

- If battery acid spills on any clothing, remove it immediately.
- If acid contacts skin, rinse the affected area with running water for 10 to 15 minutes.
- If acid contacts eyes, flood eyes with running water for 10 to 15 minutes. See a doctor at once. Never use any medication or eye drops unless prescribed by the doctor.
- To neutralize acid spilled on the floor, use one of the following mixtures:
  - 0.5 kg (1 lbs.) of baking soda in 4 L (4 qts.) of water.
  - 0.5 L (0.5 qts.) of household ammonia in 4 L (4 qts.) of water.

The battery on the loader is a 12-volt, wet-cell battery. To access the battery, open the rear door and lift the engine cover.

The battery top must be kept clean. Clean it with an alkaline solution (ammonia or baking soda and water). After foaming has stopped, flush the battery top with clean water. If the terminals and cable connection clamps are corroded or have a build-up, disconnect the cables and clean the terminals and clamps with the same alkaline solution.

### **Using a Booster Battery (Jump-Starting)**

Use only the proper jump-starting procedure according to “Jump-Starting” on page 94.

## **Fuses and Relays**

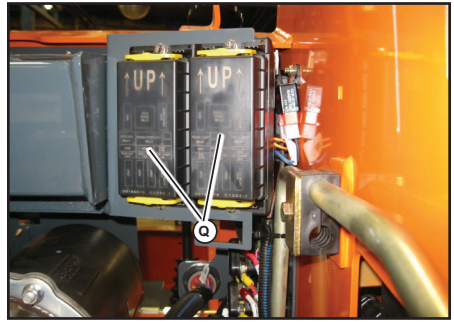

**Fig. 78 - Fuse Panels in the Engine Compartment**

The fuse panels (Q, Fig. 78) are located in the engine compartment near the chassis right riser and behind a panel in the ROPS/FOPS (S, Fig. 79) at the operator’s right elbow area. The plastic covers are either etched or have a decal with the type of fuses and relays that can be found under that particular fuse/relay cover.

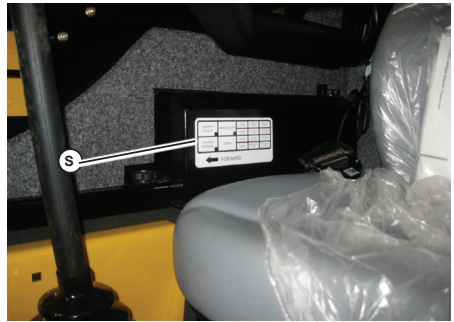

**Fig. 79 - Fuse Panel in the ROPS/FOPS**

## Windshield Washer Reservoir

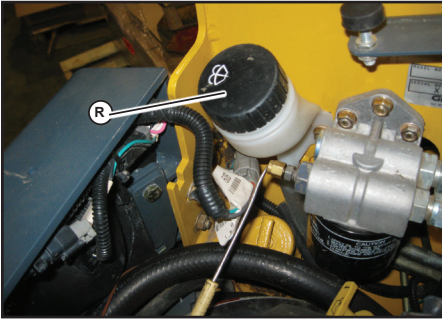

**Fig. 80 - Windshield Washer Reservoir Fill**

The windshield washer reservoir (R, Fig. 80) is located inside the engine compartment. Check the windshield washer reservoir level daily before starting the machine and fill if necessary.

**IMPORTANT:** *Fill the windshield washer fluid reservoir with clean tap water or windshield washer fluid only. If using tap water, add a cleaning agent if required and/or antifreeze in cold weather.*









# MAINTENANCE

---

# Chapter 9

## TROUBLESHOOTING

### Engine Troubleshooting







<b>Problem</b>	<b>Possible Cause</b>	<b>Corrective Action</b>
Engine does not turn over.	Blown Fuse	Check circuit and replace fuse.
	Dead Battery	Charge or replace battery.
	Battery disconnect switch in open position or malfunctioning	Place battery disconnect switch into closed position. Repair or replace if necessary.
	Starter malfunction	Contact dealer.
	Operator not in operator's seat	Operator's seat must be occupied for the engine to start.
	Malfunctioning seat/restraint bar/door switch	Replace seat/restraint bar/door switch.
	Cab door open (if equipped)	Close cab door.
	Engine electronics logic error	Contact dealer.
	Engine fault code(s) displayed	Contact dealer.
	Fuel pump malfunction.	Check electrical connections / voltage to fuel pump. Contact dealer.
Engine turns over but will not start.	Engine cranking speed too slow	Check battery and charge / replace as necessary - tighten battery terminals.
	Fuel tank empty	Fill tank and vent fuel system if necessary.
	Fuel filter plugged or restricted	Change fuel filter.
	Fuel paraffin separation in winter	Use winter grade diesel fuel.
	Fuel line leak	Tighten all threaded connections and clamps, replace fuel line as necessary.
	Fuel shut-off solenoid not energizing (interim Tier 4 engines only)	Check electrical connections / voltage to shut-off solenoid.
	Fuel filter restricted / fuel hose restriction	Replace filter / check for pinched fuel hose.
	Fuel pump malfunction	Contact dealer.
	Water in the fuel filter	Purse water from filter.
	Fuel valve on water separator is in the OFF position	Turn the valve to its ON position.
	Engine fault code(s) displayed	Contact dealer.

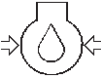

# Troubleshooting

<b>Problem</b>	<b>Possible Cause</b>	<b>Corrective Action</b>
Engine overheating	Engine too cold / ambient temperature too low	Pre-heating module malfunction; check connection and voltage and charge / replace as necessary. Install block heater.
	Crankcase oil level incorrect	Adjust oil level.
	Cooling air circulation restricted	With engine off, reposition shroud / contact dealer.
	Fan shroud improperly positioned	With engine off, reposition shroud / contact dealer.
	Improper oil grade or oil excessively dirty	Change engine oil.
	Exhaust restricted	Allow exhaust to cool; remove restriction.
	Air filter restricted	Replace filter(s)
	Low coolant level	Top off coolant.
	Loose fan belt	Tighten fan belt.
	Dirty / restricted radiator	Clean radiator.
Thermostat malfunction	Replace thermostat.	
Exhaust excessively smoky	Black smoke	Black smoke indicates poor and incomplete diesel fuel combustion.
	Blue smoke	Blue smoke indicates engine oil combustion.
	White smoke	White smoke indicates incomplete diesel fuel combustion or coolant in the combustion chamber.

## Indicator Lamp Troubleshooting

<b>Indicator Icon</b>	<b>Indicator Description</b>	<b>Possible Cause</b>	<b>Corrective Action</b>
	Engine error indicator	The engine Electronic Control Unit (ECU) has detected an error condition	Refer to the error codes section.
	Engine oil pressure	Engine oil pressure too low	Stop engine immediately. Check oil level and add oil if necessary.
		Engine oil level incorrect	Adjust oil level.
		Oil pump malfunction	Contact dealer.
	Hydraulic oil temperature	Hydraulic oil temperature is too hot	Check cooling system.
		Drive system continuously overloaded	Improve operation procedure.
		Lift / tilt or auxiliary system continuously overloaded	Improve operation procedure.
		Drive motor(s) or hydrostatic pump internal damage / leakage	Contact dealer.
		Oil cooler fins restricted	Clean oil cooler fins.
		Hydraulic oil filter restricted	Replace filter.
	Hydraulic oil filter	Hydraulic oil filter maintenance required	Replace hydraulic oil and filter. NOTE: During cold start in cold temperatures, this indicator may be activated until hydraulic oil warms to operating temperature.
	Coolant temperature	Coolant level too low	Add coolant.
		Air filter plugged	Replace air filter.
		Coolant leak	Repair cooling system and top off coolant.
	Battery voltage	Alternator not charging properly	Adjust fan belt tension Repair / replace alternator.
	Engine air filter restriction	Air filter dirty / restricted	Replace air filter(s).
		Blockage in air filter housing	Remove blockage.

# Troubleshooting

## Seal and Hose Troubleshooting

<b>Problem</b>	<b>Possible Cause</b>	<b>Corrective Action</b>
Oil, coolant or fuel leakage	Loose hose connection(s)	Tighten hose connection(s).
	Damaged seals or hoses	Change seals / hoses as necessary
Hydraulic fluid leakage	Loose fittings	Tighten hydraulic connections.
	Seal, hoses or line damaged	Change seals, hoses or lines as necessary.

## Hydraulic System Troubleshooting

<b>Problem</b>	<b>Possible Cause</b>	<b>Corrective Action</b>
Lift / Tilt controls fail to respond	Hydraulic oil viscosity is too heavy	Allow longer warm-up or replace with proper viscosity oil.
	Hydraulic oil level is too low	Check oil level in reservoir. If oil is low, check for an external leakage. Repair and add oil.
	Solenoid valve(s) malfunctioning	Check electrical connections to lift / tilt solenoid and repair.
	Restraint bar or seat switch malfunction	Check switches.
Auxiliary hydraulics do not function	Restraint bar is raised	Lower the restraint bar.
	Lock solenoid malfunctioning	Check electrical connections to lock solenoid and repair connections as needed. If lock solenoid is still not functioning properly, contact your dealer.
	Restraint bar switch malfunctioning	Check electrical connections to the restraint bar switch and repair connections as needed. If switch is still not functioning properly, contact your dealer.

## Troubleshooting

<b>Problem</b>	<b>Possible Cause</b>	<b>Corrective Action</b>
Hydraulic cylinder action is slow for lift and/or tilt functions	Low engine speed	Operate engine at higher speed.
	Hydraulic oil viscosity is too heavy	Allow longer warm-up or replace existing oil with proper viscosity oil.
	Control linkage is restricted	Check for control linkage restriction and adjust.
	Hydraulic oil leaking past cylinder piston seals	Contact your dealer.
	Solenoid valve(s) could be malfunctioning	Check electrical connections to the lift solenoid and repair connections as needed. If lift solenoid valve is still not functioning properly, contact your dealer.
	Relief valve in control valve not functioning correctly (squealing noise should be evident while operating.)	Contact your dealer.
Bucket does not level on the lift cycle	Self-leveling valve mis-adjusted or malfunctioning	Contact your dealer.
Jerky lift arm and bucket action	Seat or restraint bar switch malfunction	Contact your dealer.
	Air in the hydraulic system	Cycle lift / tilt cylinders to maximum stroke and maintain pressure for a short time to clear air from system.
	Oil in hydraulic reservoir is low	Check and add oil.
Bucket drifts downward with tilt control in neutral	Oil leaking past tilt cylinder seals (internal or external)	Contact your dealer.
	Self-leveling valve is malfunctioning	Contact your dealer.
	Leaking hydraulic hoses, tubes or fittings between control valve and cylinders	Inspect hoses and tubes, tighten fittings. Replace hoses or tubes as needed.
No down pressure on the bucket	Control valve is in its float position	Take control out of float position.
	Tilt cylinders are malfunctioning	Contact your dealer.
	Relief valve in control valve not functioning correctly (squealing noise should be evident while operating.)	Contact your dealer.
Bucket will not tilt, lift arm work properly	Tilt solenoid valve malfunctioning	Check electrical connections to the tilt solenoid and repair connections as needed. If tilt solenoid valve is still not functioning properly, contact your dealer.
	Tilt spool in control valve not actuated or leaking	Check valve control linkage and / or tube connections to valve.

# Troubleshooting

<b>Problem</b>	<b>Possible Cause</b>	<b>Corrective Action</b>
Slow or no response for bucket tilt, lift works properly (Hand/Foot machines only)	Pilot control lines have air in them	Bleed pilot control lines from the main control valve.
	Low charge pressure	Contact your dealer.
	Linkage mis-adjusted between right foot pedal and pilot valve	Readjust for full travel without restriction.
Lift arm does not raise, bucket tilt work properly	Lift solenoid valve could be malfunctioning	Check electrical connections to the lift solenoid and repair connections as needed. If lift solenoid valve is still not functioning properly, contact your dealer.
	Lift spool in control valve not actuated or leaking.	Contact your dealer.
Lift arm doesn't maintain raised position with lift control in neutral	Oil leaking past lift cylinder seals (internal or external)	Contact your dealer.
	Oil leaking past lift spool in control valve	Contact your dealer.
	Self-leveling valve malfunctioning	Contact your dealer.
	Leaking hydraulic hoses, tubes or fittings between control valve and cylinders.	Inspect hoses and tubes, tighten fittings as needed. Replace as needed.
Lift arm will not lower or raise	Lift arm support device engaged	Raise lift arm and disengage support device.
	Lift solenoid valve malfunctioning	Check electrical connections to solenoid. Repair or replaced as needed.
	Restraint bar not lowered.	Lower the restraint bar.
	Seat or restraint bar switch malfunction	Check electrical connections to the switch. Replace switch as needed.

## Hydrostatic Travel Drive System Troubleshooting

<b>Problem</b>	<b>Possible Cause</b>	<b>Corrective Action</b>
No response from either hydrostatic drive or the lift / tilt systems	Hydraulic oil viscosity is too heavy	Allow longer warm-up or replace existing oil with the proper viscosity oil.
	Hydraulic oil supply is too low	Check for low oil level in the reservoir. Add oil.
	Drive coupling failure	Replace the coupling.
Traction drive will not operate in either direction	Parking brake is engaged	Disengage the parking brake.
	Hydraulic oil supply is low	Check for low oil level in the reservoir. Add oil.
	Control rod linkage disconnected	Check linkage connection at the control levers and neutral centering mechanisms. Reconnect linkage.
	Low or no charge pressure	Contact your dealer.
	Hydrostatic pump(s) relief valve(s) are malfunctioning	Contact your dealer.
Sluggish response to acceleration	Air in hydraulic system	Cycle lift and tilt cylinders to maximum stroke and maintain pressure for a short time to clear air from system. Also check for low oil level in the reservoir, fill as needed.
	Automatic parking brake is partially engaged	Contact your dealer.
	Hydraulic oil supply is too low	Check for low oil level in the reservoir. Add oil.
	Low hydrostatic system charge pressure	Contact your dealer.
	Drive motor(s) or hydrostatic pump(s) have internal damage or leakage	Contact your dealer.
Hydrostatic drive is overheating	Drive system overloaded continuously	Improve efficiency of operation.
	Lift / tilt or auxiliary system overloaded continuously	Improve efficiency of operation.
	Drive motor(s) or hydrostatic pump(s) have internal damage or leakage	Contact your dealer.
	Oil cooler fins plugged with debris	Clean oil cooler fins.
	Machine operated in a high-temperature area with no air circulation	Reduce duty cycle; improve air circulation.

# Troubleshooting

<b>Problem</b>	<b>Possible Cause</b>	<b>Corrective Action</b>
Hydrostatic (drive) system is noisy	Hydraulic oil viscosity is too heavy	Allow longer warm-up or replace existing oil with the proper viscosity oil.
	Air in hydraulic system	Cycle lift and tilt cylinders to maximum stroke and maintain pressure for a short time to clear air from system. Also check for low oil level in the reservoir, fill as needed.
	Drive motor(s) or hydrostatic pump(s) have internal damage or leakage	Contact your dealer.
Right side doesn't drive in either direction. Left side operates normally.	Rear hydrostatic pump arm control shaft key is missing	Contact your dealer.
	Relief valves on rear hydrostatic pump malfunctioning	Contact your dealer.
	Control rod linkage to rear hydrostatic pump disconnected	Attach control rod linkage.
Right side doesn't drive in one direction	Relief valve on rear hydrostatic pump is malfunctioning	Contact your dealer.
	Rear hydrostatic pump malfunctioning	Contact your dealer.
Left side doesn't drive in either direction. Right side operates normally.	Front hydrostatic pump arm control shaft key is missing	Contact your dealer.
	Relief valves on front hydrostatic pump malfunctioning	Contact your dealer.
	Control rod linkage to front hydrostatic pump disconnected	Attach control rod linkage.
Left side doesn't drive in one direction	Relief valve on front hydrostatic pump is malfunctioning	Contact your dealer.
	Front hydrostatic pump malfunctioning	Contact your dealer.

## Electrical Troubleshooting

<b>Problem</b>	<b>Possible Cause</b>	<b>Corrective Action</b>
Electrical system does not function	Battery disconnect switch is in its OFF position	Turn battery disconnect switch to its ON position.
	Battery terminals or cable loose or corroded	Clean battery terminals and cables and re-tighten.
	Battery malfunction	Test battery. Recharge / replace as necessary.
	Blown main fuse	Correct over-current problem and replace main fuse.
	Main wiring harness connectors at rear of ROPS/FOPS not properly plugged in	Check main harness connectors. Reconnect / repair as needed.
Control pad and information center display do not activate with ignition key switch in the ON/RUN position	Blown fuse	Check circuit and replace fuse.
	Battery terminals / cables loose / corroded	Clean battery terminals and cables and tighten.
	Main wiring harness connectors at rear of ROPS/FOPS not properly plugged in	Check main harness connectors. Reconnect / repair as needed.
Starter does not engage when ignition key switch turned to its START position	Poor electrical connections in start circuit	Check connections; repair as necessary.
	Battery terminals / cables loose / corroded	Clean battery terminals and cables and tighten.
	Starter relay malfunction	Test relay; replace if necessary. Contact dealer.
	Battery discharged / malfunctioning	Test battery. Recharge / replace if necessary.
	Starter solenoid malfunction	Contact dealer.
	Starter or pinion malfunctioning	Repair / replace as needed.
	Ignition wiring, seat switch, restraint bar switch, etc. loose or disconnected	Check wiring for poor connections, broken leads; repair wiring or connection.
	Restraint bar raised	Lower restraint bar.
	Engine fault code(s)	Contact dealer.
Fuel gauge inoperative	Fuel level sender malfunction	Replace fuel level sender.
	Loose wiring / terminal connections	Check wiring connections.
	Blown fuse	Check circuit and replace fuse.
	Fuel gauge malfunction	Replace gauge.



# Troubleshooting

<b><i>Problem</i></b>	<b><i>Possible Cause</i></b>	<b><i>Corrective Action</i></b>
Coolant temperature gauge is inoperative	Temperature sender malfunction	Replace temperature sender.
	Loose wiring / terminal connections	Check wiring connections.
	Blown fuse	Check circuit and replace fuse.
	Coolant temperature gauge malfunction	Replace gauge.
Hour meter is inoperative	Loose wiring / terminal connections	Check wiring connections.
	Alternator malfunction	Repair / replace alternator.
	Hour meter malfunction	Replace information center electronic display.
Work / road lights inoperative	Single light not working - light bulb burned out, faulty wiring	Check and replace light bulb as needed, check wiring connections.
	No lights - blown fuse	Check circuit and replace fuse.
	Light switch malfunction, poor ground or other wiring connection	Check ground / wire connections, replace light switch.
Lift / Tilt and / or drive lock solenoid malfunction	Solenoid wiring disconnected or faulty	Check circuit; repair as necessary.
	Seat or restraint bar switch malfunction	Contact dealer.

## Error Codes

DTC code				Number of the lamp flashes	Part	Error item	Reference page		
P code	SPN		FMI				State	Description	Failure diagnosis
	Decima number	Hexadecimal number	Decima number						
P0336	522400	7F8A0	2	MIL + AWL	Crank speed sensor	Crank signal malfunction	P7	P290	
P0337			5	MIL + AWL			No crank signal	P9	P290
P0341	522401	7F8A1	2	MIL + AWL	Cam speed sensor	Cam signal malfunction	P11	P293	
P0342			5	MIL + AWL			No cam signal	P13	P293
P1341			7	MIL + AWL			Angle offset failure	P15	–
P0008	523249	7FBF1	5	MIL + RSL	Crank speed, Cam speed sensor	No signal on both crank and cam speed sensor	P17	P290, P293	
P0123	91	5B	3	MIL + AWL	Accelerator sensor 1	Accelerator sensor 1 (Excessive sensor output)	P18	P297	
P0122			4	MIL + AWL			Accelerator sensor 1 (Insufficient sensor output)	P20	P297
P0223	28	1C	3	MIL + AWL	Accelerator sensor 2	Accelerator sensor 2 (Excessive sensor output)	P22	P297	
P0222			4	MIL + AWL			Accelerator sensor 2 (Insufficient sensor output)	P24	P297
P1646	522624	7F980	7	MIL + AWL	Accelerator sensor 1 + 2	Dual accelerator sensor (closed position) failure	P26	–	
P1647	522623	7F97F	7	MIL + AWL		Dual accelerator sensor (open position) failure	P28	–	
P0228	29	1D	3	MIL + AWL	Accelerator sensor 3	Accelerator sensor 3 (Excessive sensor output)	P30	P297	
P0227			4	MIL + AWL			Accelerator sensor 3 (Insufficient sensor output)	P32	P297
P1227			8	MIL + AWL	Pulse sensor	Pulse sensor failure (Pulse communication)	P34	–	
P1126	28	1C	0	MIL + AWL	Accelerator sensor 3	Accelerator sensor 3 failure (Foot pedal in open position)	P35	–	
P1125			1	MIL + AWL			Accelerator sensor 3 failure (Foot pedal in closed position)	P37	–
P02E9	51	33	3	MIL + RSL	Intake throttle opening sensor	Intake throttle opening sensor fault (High voltage)	P38	P301	
P02E8			4	MIL + RSL			Intake throttle opening sensor fault (Low voltage)	P40	P301
P0238	102	66	3	MIL + RSL	EGR low pressure side sensor	EGR low pressure side sensor fault (High voltage)	P42	P304	
P0237			4	MIL + RSL			EGR low pressure side sensor fault (Low voltage)	P44	P304
P0236			13	MIL + RSL			EGR low pressure side sensor (Abnormal learning value)	P46	P304
P0473	1209	4B9	3	MIL + RSL	EGR high pressure side sensor	EGR high pressure side sensor fault (High voltage)	P48	P307	
P0472			4	MIL + RSL			EGR high pressure side sensor fault (Low voltage)	P50	P307
P0471			13	MIL + RSL			EGR high pressure side sensor (Abnormal learning value)	P52	P307
P0118	110	6E	3	MIL + AWL	Cooling water temperature sensor	Cooling water temperature sensor fault (High voltage)	P54	P310	
P0117			4	MIL + AWL			Cooling water temperature sensor fault (Low voltage)	P56	P310
P0217			0	Select by application			Cooling water temperature sensor temperature abnormal high (Overheat)	P58	P310
P0113	172	AC	3	MIL + AWL	New air temperature sensor	New air temperature sensor fault (High voltage)	P60	P314	
P0112			4	MIL + AWL			New air temperature sensor fault (Low voltage)	P62	P314
P0183	174	AE	3	MIL + AWL	Fuel temperature sensor	Fuel temperature sensor fault (High voltage)	P64	P318	
P0182			4	MIL + AWL			Fuel temperature sensor fault (Low voltage)	P66	P318
P0168			0	Select by application			Fuel temperature sensor temperature abnormal high	P68	P318

# Troubleshooting

P code	DTC code			Number of the lamp flashes	Part	Error item	Reference page		
	SPN		FMI				Description	Failure diagnosis	
	Decima number	Hexadecimal number	Decima number						
P0193	157	9D	3	MIL + RSL	Rail pressure sensor	Rail pressure sensor fault (High voltage)		P70	P322
P0192			4	MIL + RSL		Rail pressure sensor fault (Low voltage)		P72	P322
P2455	3251	CB3	3	MIL + RSL	DPF differential pressure sensor	DPF differential pressure sensor fault (High voltage)		P74	P325
P2454			4	MIL + RSL		DPF differential pressure sensor fault (Low voltage)		P76	P325
P2452			0	MIL + RSL		DPF differential pressure sensor differential pressure abnormal high		P78	P325
			13	MIL + RSL		DPF differential pressure sensor (Abnormal learning value)		P80	P325
P1455	3609	E19	3	MIL + RSL	DPF high pressure side sensor	DPF high pressure side sensor fault (High voltage)		P82	P325
P1454			4	MIL + RSL		DPF high pressure side sensor fault (Low voltage)		P84	P325
P1428	3242	CAA	3	MIL + RSL	DPF inlet temperature sensor	DPF inlet temperature sensor fault (High voltage)		P86	P329
P1427			4	MIL + RSL		DPF inlet temperature sensor fault (Low voltage)		P88	P329
P1436			0	MIL + AWL		DPF inlet temperature sensor temperature abnormal high		P90	P329
P1434			3	MIL + RSL		DPF intermediate temperature sensor fault (High voltage)		P91	P333
P1435	3250	CB2	4	MIL + RSL	DPF intermediate temperature sensor	DPF intermediate temperature sensor fault (Low voltage)		P93	P333
P0420			1	MIL + AWL		DPF intermediate temperature sensor temperature abnormal low temperature		P95	P333
P1426			0	MIL + RSL		DPF intermediate temperature sensor temperature abnormal high (Post-injection failure)		P96	P333
			P2229	3		MIL + AWL	Atmospheric pressure sensor fault (High voltage)		P97
P2228	108	6C	4	MIL + AWL	Atmospheric pressure sensor	Atmospheric pressure sensor fault (Low voltage)		P98	P390
P1231			10	MIL + AWL		Atmospheric pressure sensor characteristic fault		P99	P390
P041D	412	19C	3	MIL + AWL	EGR gas temperature sensor	EGR gas temperature sensor fault (High voltage)		P101	P337
P041C			4	MIL + AWL		EGR gas temperature sensor fault (Low voltage)		P103	P337
P040D	105	69	3	MIL + RSL	Intake manifold temperature sensor	Intake manifold temperature sensor fault (High voltage)		P105	P341
P040C			4	MIL + RSL		Intake manifold temperature sensor fault (Low voltage)		P107	P341
P0546	173	AD	3	MIL + AWL	Exhaust manifold temperature sensor	Exhaust manifold temperature sensor fault (High voltage)		P109	P345
P0545			4	MIL + AWL		Exhaust manifold temperature sensor fault (Low voltage)		P111	P345
P068B	1485	5CD	7	MIL + AWL	Main relay	Main relay contact stuck		P113	P349
P068A			2	MIL + AWL		Main relay early opening		P115	P349
P0543	522243	7F803	5	MIL + AWL	Startup assist relay	Startup assist relay interrupted		P117	P353
P0541			6	MIL + AWL		Startup assist relay GND interrupted		P119	P353
P0204 (4TNV), P0203 (3TNV)	651 (4TNV), P0268 (3TNV)	28B (4TNV), 28C (3TNV)	5	MIL + RSL	Injector 1 4TNV: Cyl No. 4 3TNV: Cyl No. 3 Corresponding port 4TNV: 1 - 2 3TNV: 1 - 3	Injector 1 open circuit (Inherent location of the injector)		P121	P364
P0271 (4TNV), P0268 (3TNV)			6	MIL + RSL		Injector 1 coil short circuit		P123	P364
P1271 (4TNV), P1262 (3TNV)			3	MIL + RSL		Injector 1 short circuit		P125	P368
P0202	653	28D	5	MIL + RSL	Injector 2 4TNV: Cyl No. 2 3TNV: Cyl No. 2 Corresponding port 4TNV: 2 - 1 3TNV: 1 - 2	Injector 2 open circuit (Inherent location of the injector)		P127	P364
P0265			6	MIL + RSL		Injector 2 coil short circuit		P129	P364
P1265			3	MIL + RSL		Injector 2 short circuit		P131	P368

P code	DTC code			Number of the lamp flashes	Error item		Reference page		
	SPN		FMI		Part	State	Description	Failure diagnosis	
	Decima number	Hexadecimal number	Decima number						
P0201	654	28E	5	MIL + RSL	Injector 3	Injector 3 open circuit (Inherent location of the injector)	P133	P364	
P0262			6	MIL + RSL	4TNV: Cyl No. 1 3TNV: Cyl No. 1	Injector 3 coil short circuit	P135	P364	
P1262			3	MIL + RSL	Corresponding port 4TNV: 2 - 2 3TNV: 1 - 1	Injector 3 short circuit	P137	P368	
P0203	652	28C	5	MIL + RSL	Injector 4	Injector 4 open circuit (Inherent location of the injector)	P139	P364	
P0268			6	MIL + RSL	4TNV: Cyl No. 3 Corresponding port	Injector 4 coil short circuit	P141	P364	
P1268			3	MIL + RSL	4TNV: 1 - 1	Injector 4 short circuit	P143	P368	
P0611	4257	10A1	12	MIL + RSL		Injector drive IC error	P145	-	
P1146	2797	AED	6	MIL + RSL	Injector (common)	Injector drive circuit (Bank1) short circuit (4TN: Common circuit for No. 1, No. 4 and all 3TN cylinders)	P146	P368	
P1149	2798	AEE	6	MIL + RSL		Injector drive circuit (Bank 2) short circuit (4TN: Circuit for No. 2 and No. 3 cylinders)	P148	P368	
P1648	523462	7FCC6	13	MIL + RSL	Injector (correction value)	IQA corrected injection amount for injector 1 error	P150	-	
P1649	523463	7FCC7	13	MIL + RSL		IQA corrected injection amount for injector 2 error	P151	-	
P1650	523464	7FCC8	13	MIL + RSL		IQA corrected injection amount for injector 3 error	P152	-	
P1651	523465	7FCC9	13	MIL + RSL		IQA corrected injection amount for injector 4 error	P153	-	
P1641	522571	7F94B	3	MIL + RSL	SCV (MPROP)	High-pressure pump drive circuit (Low side VB short-circuit)	P154	P370	
P1643			6	MIL + RSL		High-pressure pump drive circuit (Low side GND short-circuit)	P155	P370	
P0629			3	MIL + RSL		High-pressure pump drive circuit (High side VB short-circuit)	P157	P370	
P1642	633	279	6	MIL + RSL		High-pressure pump drive circuit (High side GND short-circuit)	P159	P370	
P0627			5	MIL + RSL		High-pressure pump drive circuit (Open circuit)	P160	P370	
P062A	522572	7F94C	6	MIL + RSL		High-pressure pump drive circuit (Drive current (high level))	P161	P370	
P1645			11	MIL + RSL		High-pressure pump drive circuit (Pump overload error)	P163	P370	
P0088	157	9D	0	MIL + RSL		Abnormal rail pressure	Actual rail pressure rise error	P165	-
P0094			18	MIL + RSL			Rail pressure deviation error during the actual rail pressure drop	P167	-
P0093			15	MIL + RSL			Rail pressure deviation error during the actual rail pressure rise	P169	-
P000F			16	MIL + RSL	PLV open valve		P171	-	
P1666			523469	7FCCD	0		MIL + RSL	Rail pressure fault (The times of PLV valve opening error)	P173
P1667	523470	7FCE0	0	MIL + RSL	PLV (Common rail pressure limit valve)	Rail pressure fault (The time of PLV valve opening error)	P175	-	
P1668	523489	7FCE1	0	MIL + RSL		Rail pressure fault (The actual rail pressure is too high during PRV limp home)	P177	-	
P1665	523488	7FCCC	9	MIL + RSL		Rail pressure fault (Controlled rail pressure error after PLV valve opening)	P179	-	
P1669	523491	7FCE3	0	MIL + RSL		Rail pressure fault (Injector BIF temperature error during PLV4 limp home)	P181	-	
P1670	523460	7FCC4	7	MIL + RSL	Rail pressure control	Rail pressure fault (Operation time error during RPS limp home)	P183	-	
P0219	190	BE	16	MIL + RSL	Overspeed	Overspeed	P285	P393	
P0660	2950	B86	5	MIL + AWL	Intake throttle drive circuit	No-load of throttle valve drive H bridge circuit	P184	P373	
P1658			3	MIL + AWL		Power short circuit of throttle valve drive H bridge output 1	P185	P373	
P1659			4	MIL + AWL		GND short circuit of throttle valve drive H bridge output 1	P186	P373	
P1660			6	MIL + AWL		Overload on the drive H bridge circuit of throttle valve	P187	P373	
P1661			2951	B87		3	MIL + AWL	VB Power short circuit of throttle valve drive H bridge output 2	P188
P1662			4	MIL + AWL		GND short circuit of throttle valve drive H bridge output 2	P189	P373	

# Troubleshooting

DTC code					Number of the lamp flashes	Error item		Reference page	
P code	SPN		FMI	Part		State	Description	Failure diagnosis	
	Decima number	Hexadecimal number	Decima number						
U0292	522596	7F964	9	MIL + AWL	CAN2	TSC1 (CAN message) reception time out (SA1)	P210	P387	
U1301	522597	7F965	9	MIL + AWL		TSC1 (CAN message) reception time out (SA2)	P212	P387	
U1292	522599	7F967	9	MIL + AWL		Y_ECR1 (CAN message) reception time out	P214	P387	
U1293	522600	7F968	9	MIL + AWL		Y_EC (CAN message) reception time out	P216	P387	
U1294	522601	7F969	9	MIL + AWL		Y_RSS (CAN message) reception time out	P218	P387	
U1296	522603	7F96B	9	MIL + AWL		VH (CAN message) reception time out	P220	P387	
U1298	522605	7F96D	9	MIL + AWL		Y_ECM3 (CAN message) reception time out	P222	P387	
U0168	237	ED	31	MIL + AWL		VI (CAN message) reception time out	P224	P387	
U3002			13	MIL + AWL		VI (CAN message) reception data fault	P226	P387	
U1300	522609	7F971	9	MIL + AWL		Y_ETCP1 (CAN message) reception time out	P228	P387	
U1302	522618	7F97A	9	MIL + AWL		EBC1 (CAN message) reception time out	P230	P387	
U1303	522619	7F97B	9	MIL + AWL		Y_DPFIF (CAN message) reception time out	P232	P387	
U010B	522610	7F972	9	MIL + AWL		CAN1 (for EGR): Reception time out	P208	P384	
U1107	522611	7F973	9	TBD			Exhaust throttle (CAN message from the exhaust throttle time out)	P209	P384
P0404	2791	AE7	0	MIL + AWL	EGR valve	EGR over-voltage fault	P190	P378	
P1404			1	MIL + AWL		EGR under-voltage fault	P191	P378	
P1409			7	MIL + AWL		EGR feedback malfunction	P192	P382	
U0401			9	MIL + AWL		EGR ECM data fault	P193	P382	
P0403			12	MIL + AWL		Open circuit between the EGR motor coils	P194	P382	
P1405	522579	7F953	12	MIL + AWL		Short circuit between the EGR motor coils	P195	P382	
P0488	522580	7F954	12	MIL + AWL		EGR position sensor malfunction	P196	P382	
P148A	522581	7F955	7	MIL + RSL		EGR stuck open valve malfunction	P197	P382	
P049D	522582	7F956	7	MIL + RSL		EGR initialization malfunction	P198	P382	
P1410	522183	7F957	1	MIL + AWL		EGR high temperature thermistor malfunction	P200	P382	
P1411	522184	7F958	1	MIL + AWL		EGR low temperature thermistor malfunction	P201	P382	
U1401	522617	7F979	12	MIL + AWL		EGR target value out of range	P199	P382	
P1438	522746	7F9FA	12	TBD		Exhaust throttle	Exhaust throttle (Voltage fault)	P202	-
P1439	522747	7F9FB	12	TBD			Exhaust throttle (Motor fault)	P203	-
P1440	522748	7F9FC	12	TBD	Exhaust throttle (Sensor system fault)		P204	-	
P1441	522749	7F9FD	12	TBD	Exhaust throttle (MPU fault)		P205	-	
P1442	522750	7F9FE	12	TBD	Exhaust throttle (PCB fault)		P206	-	
P1443	522751	7F9FF	19	TBD	Exhaust throttle (CAN fault)		P207	-	
P0601	630	276	12	MIL + RSL	EEPROM		EEPROM memory deletion error	P234	P390
P160E	522576	7F950	12	MIL + RSL			EEPROM memory read error	P235	P390
P160F	522578	7F952	12	MIL + RSL		EEPROM memory writing error	P236	P390	

P code	DTC code			Number of the lamp flashes	Part	Error item	Reference page	
	SPN		FMI				Description	Failure diagnosis
	Decima number	Hexadecimal number	Decima number					
P1613	522585	7F959	12	MIL + RSL	ECU internal fault	CY146 SPI communication fault	P237	P390
P1608	522588	7F95C	12	MIL + RSL		Excessive voltage of supply 1	P238	P390
P1617	522589	7F95D	12	MIL + RSL		Insufficient voltage of supply 1	P239	P390
P1609	522590	7F95E	12	None		Sensor supply voltage error 1	P240	-
P1618	522591	7F95F	12	None		Sensor supply voltage error 2	P241	-
P1619	522592	7F960	12	None		Sensor supply voltage error 3	P242	-
P1626	522744	7F9F8	4	MIL + AWL		Actuator drive circuit 1 short to ground	P243	-
P1633	522994	7FAF2	4	MIL + AWL		Actuator drive circuit 2 short to ground	P244	-
P1467	523471	7FCFC	6	MIL + AWL		Actuator drive circuit 3 short to ground	P245	-
P1469	523473	7FCD1	12	MIL + RSL		AD converter fault 1	P246	P390
P1470	523474	7FCD2	12	MIL + RSL		AD converter fault 2	P247	P390
P1471	523475	7FCD3	12	MIL + RSL		External monitoring IC and CPU fault 1	P248	P390
P1472	523476	7FCD4	12	MIL + RSL		External monitoring IC and CPU fault 2	P249	P390
P1473	523477	7FCD5	12	MIL + RSL		ROM fault	P250	P390
P1474	523478	7FCD6	12	MIL + RSL		Shutoff path fault 1	P251	P390
P1475	523479	7FCD7	12	MIL + RSL		Shutoff path fault 2	P252	P390
P1476	523480	7FCD8	12	MIL + RSL		Shutoff path fault 3	P253	P390
P1477	523481	7FCD9	12	MIL + RSL		Shutoff path fault 4	P254	P390
P1478	523482	7FCDA	12	MIL + RSL		Shutoff path fault 5	P255	P390
P1479	523483	7FCDB	12	MIL + RSL		Shutoff path fault 6	P256	P390
P1480	523484	7FCDC	12	MIL + RSL		Shutoff path fault 7	P257	P390
P1481	523485	7FCDD	12	MIL + RSL		Shutoff path fault 8	P258	P390
P1482	523486	7FCDE	12	MIL + RSL		Shutoff path fault 9	P259	P390
P1483	523487	7FCDF	12	MIL + RSL		Shutoff path fault 10	P260	P390
P1484	523488	7FCE0	0	MIL + RSL		Recognition error of engine speed	P261	-
P1101	522323	7F853	0	Select by application		Air cleaner switch	Air cleaner clogged alarm	P262
P1151	522329	7F859	0	Select by application	Oil/water separator switch	Oil/water separator alarm	P264	P361
P1562	167	A7	5	Select by application	Charge switch	Charge switch open circuit	P266	P357
P1568			1	Select by application		Charge alarm	P268	P357
P1192	100	64	4	Select by application	Oil pressure switch	Oil pressure switch open circuit	P270	P357
P1198			1	Select by application		Low oil pressure fault alarm	P272	P357
P2463	522573	7F94D	0	Not turned on	DPF	Overaccumulation (Method C)	P274	-
P1463	522574	7F94E	0	Not turned on		Overaccumulation (Method P)	P275	-
P2458	522575	7F94F	7	Not turned on		Regeneration defect (Stationary regeneration failure)	P276	-
P2459	522577	7F951	11	Not turned on		Regeneration defect (Stationary regeneration not performed)	P277	-
P242F	3720	E88	16	MIL + AWL	DPF OP interface	Ash cleaning request 1	P278	-
P1420			0	MIL + RSL		Ash cleaning request 2	P279	-
P1421	3719	E87	16	MIL + AWL	Stationary regeneration standby	P280	-	
P1424			0	MIL + RSL	Backup mode	P281	-	
P1425	3695	E6F	14	Not turned on	Reset regeneration prohibited	P282	-	
P1445	3719	E87	9	MIL + RSL	Recovery regeneration failure	P283	-	
P1446			7	MIL + RSL	Recovery regeneration prohibition	P284	-	

# Troubleshooting

---

SPN	FM	P-CODE	PART	STATE
102	10	P1673	EGR Low Pres. Sensor Malfunction	Aftertreatment Error
105	10	P1676	Intake Air Temp. Sensor Malfunction	Aftertreatment Error
110	10	P1674	Coolant Temp. Sensor Malfunction	Aftertreatment Error
173	10	P1677	Exhaust Temp. Sensor Malfunction	Aftertreatment Error
412	10	P1675	EGR Gas Temp Sensor Malfunction	Aftertreatment Error
1209	10	P1679	EGR High Pres. Sensor Malfunction	Aftertreatment Error
3242	10	P167E	DPF Inlet Temp. Sensor Malfunction	Aftertreatment Error
3250	10	P167A	DPF Intermediate Temp Sensor Malfunction	Aftertreatment Error
3609	10	P167C	DPF High Pres. Sensor Malfunction	Aftertreatment Error
4795	31	P226D	DPF Substrate Removed	Aftertreatment Error

---

# Index

## D

<b>Decals .....</b>	<b>27</b>
ANSI-Style Decals .....	29
Common Decals .....	28
Decal Locations .....	27
General Information .....	27
ISO-Style Decals .....	33
New Decal Application .....	27

## I

<b>Indicators and Controls .....</b>	<b>47</b>
Battery Disconnect Switch .....	59
Beacon (Option) .....	59
Cab Heat (Option) .....	58
Display(s) .....	48
Emergency Lift Arm Lower .....	57
Hand/Foot Controls .....	57
Horn .....	58
Information Center Electronic Display .....	48
Information Center Electronic Display Screens .....	51
Information Center Electronic Display Symbols .....	49
Instrument Panel .....	55
Lift Arm Float .....	57
Operator's Seat .....	56
Parking Brake/ Hydraulics Transport Lockout .....	57
Switch Panel .....	54

T-Bar Controls .....	57
Throttle Controls .....	56
Travel Controls .....	57
Windshield Wiper/Washer .....	58

<b>Introduction .....</b>	<b>5</b>
Component Identification .....	8
Component Serial Numbers .....	7
Contents and Use of this Manual ..	5
Fire Extinguisher .....	11
Indicator and Operation Symbols	12
Machine Model and Serial Numbers .....	7
Machine Orientation .....	6
Manufacturer Information .....	11
Safety Symbol and Signal Words .	5
Service and Registration .....	6
Signal Words .....	5
Using Attachments .....	10
Vibration Information .....	10
Vibration Levels .....	11
Vibration Measurement and Actions .....	10

## L

<b>Lubrication .....</b>	<b>101</b>
Filter Table .....	101
Lubricant Capacities .....	101
Lubrication Points .....	102
Lubrication Schedule/Intervals .	104
Types of Lubricants .....	101



---

## M

<b>MAINTENANCE .....</b>	<b>107</b>
Adding Fuel.....	113
Alternator/Fan Belt.....	117
Battery .....	121
Changing Engine Oil and Filter	109
Changing Fuel Filter .....	110
Changing Hydraulic Oil and Filter.....	115
Check Engine Mounting Hardware .....	109
Checking Coolant Level.....	116
Checking Engine Oil Level.....	109
Checking Hydraulic Oil Level..	114
Cleaning Cooling System.....	116
DPF Exhaust System Service....	112
Draining/Flushing Cooling System .....	117
Electrical System.....	121
Engine Air Filters .....	111
Engine Cooling System.....	116
Engine Maintenance.....	109
Fuel System Maintenance .....	112
Fuses and Relays .....	122
Hydraulic Hose Maintenance....	118
Hydraulic System Maintenance .....	114
Maintenance Interval .....	107
Maintenance Log.....	124
Maintenance Schedule .....	107
Track Maintenance .....	119
Track Replacement .....	119
Tracks .....	119
Travel Motor Front Case Oil .....	118

Travel Motor Maintenance.....	118
Using a Booster Battery (Jump-Starting).....	118
Water Separator Inspection/Maintenance .....	113
Windshield Washer Reservoir...	123

## O

<b>OPERATION .....</b>	<b>61</b>
After Operation.....	94
After Starting.....	65
Auxiliary Hydraulics Operation..	82
Backfilling Holes and Embankments .....	86
Back-up Alarm .....	72
Before Disposal .....	99
Before Operation.....	62
Cab Entry and Exit.....	62
Cold-Starting .....	64
Joystick Controls.....	70
Connecting Attachments .....	80
Connecting/Disconnecting Attachments .....	79
Connecting Hydraulic Attachments to the Auxiliary Hydraulic Circuits.	81
Crane Lifting Preparation.....	95
Diesel Particulate Filter (DPF) Regeneration Procedures.....	90
Digging Tips .....	84
Digging with a Standard Bucket.	85
Disconnecting Attachments .....	80
Disconnecting Hydraulic Attachments from the Auxiliary Hydraulic s Circuits.....	81
Disengage Lift Arm Support.....	77

Disengage Parking Brake.....	63	Removing Machine from Storage .....	99
DPF Maintenance.....	93	Reset Regeneration.....	91
Engage Lift Arm Support.....	76	Reset Regeneration Inhibit.....	91
Engine Warm Up` .....	65	Rubber Track Use Cautions and Tips .....	72
Fastening / Unfastening the Seat Belt.....	62	Run-In Period	66
Final Shutdown / Decommissioning.....	99	Safety Interlock System (Hydraloc™) .....	66
Float Control.....	79	Seat Belt.....	62
Forcing Stationary Regeneration.....	93	Self-Leveling (Option) .....	79
Grading Using Float.....	87	Setting Down Loads Using Pallet Forks.....	90
Grading without Float .....	87	Sprocket Tooth Wear and Track Life .....	74
Hand/Foot Controls .....	68	Starting the Engine .....	63
Hand/Foot Drive Controls.....	68	Stationary Regeneration .....	92
Hand/Foot Lift and Tilt Controls	69	Stopping the Engine .....	66
Jump-Starting .....	94	Storing the Machine .....	93
Lift Arm Lift Support .....	76	T-Bar Controls .....	67
Lifting Loads Using Pallet Forks	89	T-Bar Drive Controls.....	67
Lifting the Machine using a Crane.....	95	T-Bar Lift and Tilt Controls .....	68
Loading a Bucket .....	85	Testing the Safety Interlock System.....	66
Loading and Securing the Machine .....	98	Tips When Loading Trucks.....	86
Loading and Transporting the Machine on a Transport Vehicle.....	97	Towing / Transporting the Machine .....	96
Loading Pallet Forks .....	89	Transporting Loads Using Pallet Forks . . . . .	89
Loading Trucks (or Hoppers).....	86	Travel Drive Operation .....	67
Long-Term Storage .....	99	Working with Buckets.....	83
Machine Disposal.....	100	Working with Pallet Forks .....	88
Operational Checks/ Pre-start Inspection.....	61		
Parking Brake .....	63		
Powering Attachments with Hydraulic Function.....	80		

## S

<b>Safety.....</b>	<b>15</b>
Additional Safety Equipment.....	25
Applications with Load-Handling Devices .....	20
Battery Hazards .....	24
Before Starting .....	17
Crystalline Silica Exposure.....	25
During Operation.....	18
Electrical Energy .....	21
Fire Hazards .....	24
Maintenance and Service Safety Practices .....	22
Mandatory Safety Shutdown Procedure .....	16
Parking the Machine .....	21
Safety Symbol and Signal Words	15
Signal Words .....	15

## **Specifications..... 37**

Common Materials and Densities .....	45
Coolant Compound Table .....	40
Dimensions.....	38
Engine.....	40
Fluids/Lubricants Types and Capacities.....	37
Hydraulic System .....	42
Payloads/Capacities.....	39
Sound Power/Pressure Levels....	42
Standard and Optional Features..	44
Tracks .....	40
Vibration Levels .....	43
Weights .....	40

## T

<b>Troubleshooting .....</b>	<b>129</b>
Electrical Troubleshooting .....	137
Engine Troubleshooting .....	129
Error Codes.....	139
Hydraulic System Troubleshooting.....	132
Hydrostatic Travel Drive System Troubleshooting.....	135
Indicator Lamp Troubleshooting.....	131
Seal and Hose Troubleshooting.....	132

## Torque Specifications

**NOTE:** Use these torque values when tightening hardware (excluding: locknuts and self-tapping, thread forming and sheet metal screws) unless specified otherwise.

Hydraulic fittings with various seals (light application). All torque values are in Nm (lb.-ft.) unless marked otherwise.					
Thread	Straight pipe fitting with thread and screwed plug (GE)			Non-return valve with elastic seal	Identification aid outside Ø
	Sealing washer	Elastic seal	O-ring		
M10X1.0	9 (7)	18 (13)	15 (11)	18 (13)	10 mm (0.4 in.)
M12X1.5	20 (15)	25 (18)	25 (18)	25 (18)	12 mm (0.5 in.)
M14X1.5	35 (26)	45 (33)	26 (35)	35 (26)	14 mm (0.6 in.)
M16X1.5	45 (33)	55 (41)	40 (30)	50 (37)	16 mm (0.6 in.)
M18X1.5	55 (41)	70 (52)	45 (33)	70 (52)	18 mm (0.7 in.)
M22X1.5	65 (48)	125 (92)	60 (44)	125 (92)	22 mm (0.9 in.)
M27X2.0	90 (66)	180 (133)	100 (74)	145 (107)	27 mm (1.0 in.)
M33X2.0	150 (111)	310 (229)	160 (118)	210 (155)	33 mm (1.3 in.)
M42X2.0	240 (177)	450 (332)	210 (155)	360 (266)	42 mm (1.7 in.)
M48X2.0	290 (214)	540 (398)	260 (192)	540 (398)	48 mm (1.9 in.)
G1/8A	9 (7)	13 (18)	15 (11)	18 (13)	9.73 mm (0.4 in.)
G1/4A	35 (26)	35 (26)	30 (22)	35 (26)	13.16 mm (0.5 in.)
G3/8A	45 (33)	70 (52)	45 (33)	50 (37)	16.66 mm (0.7 in.)
G1/2A	65 (48)	90 (66)	55 (41)	65 (48)	20.96 mm (0.8 in.)
G3/4A	90 (66)	180 (133)	100 (74)	140 (103)	26.44 mm (1.0 in.)
G1A	150 (111)	310 (229)	160 (118)	190 (140)	33.25 mm (1.3 in.)
G1 1/4A	240 (177)	450 (332)	210 (155)	360 (266)	41.91 mm (1.7 in.)
G1 1/2A	290 (214)	540 (398)	260 (192)	540 (398)	47.80 mm (1.9 in.)

**Hydraulic fittings with various seals (heavy application). All torque values are in Nm (lb.-ft.) unless marked otherwise.**

Thread	Straight pipe fitting with thread and screwed plug (GE)			Non-return valve with elastic seal	Identification aid outside Ø
	Sealing washer	Elastic seal	O-ring		
M12X1.5	20 (15)	35 (26)	35 (26)	35 (26)	12 mm (0.5 in.)
M14X1.5	35 (26)	55 (41)	45 (33)	45 (33)	14 mm (0.6 in.)
M16X1.5	45 (33)	70 (52)	55 (41)	55 (41)	16 mm (0.6 in.)
M18X1.5	55 (41)	90 (66)	70 (52)	70 (52)	18 mm (0.7 in.)
M20X1.5	55 (41)	125 (92)	80 (59)	100 (74)	20 mm (0.8 in.)
M22X1.5	65 (48)	135 (100)	100 (74)	125 (92)	22 mm (0.9 in.)
M27X2.0	90 (66)	180 (133)	170 (125)	135 (100)	27 mm (1.0 in.)
M33X2.0	150 (111)	310 (229)	310 (229)	210 (155)	33 mm (1.3 in.)
M42X2.0	240 (177)	450 (332)	330 (243)	360 (266)	42 mm (1.7 in.)
M48X2.0	290 (214)	540 (398)	420 (310)	540 (398)	48 mm (1.9 in.)
G1/8A	35 (26)	55 (41)	45 (33)	45 (33)	13.16 mm (0.5 in.)
G1/4A	45 (33)	80 (59)	60 (44)	60 (44)	16.66 mm (0.7 in.)
G3/8A	65 (48)	115 (85)	75 (55)	100 (74)	20.96 mm (0.8 in.)
G1/2A	90 (66)	180 (133)	170 (125)	145 (107)	26.44 mm (1.0 in.)
G3/4A	150 (111)	310 (229)	310 (229)	260 (192)	33.25 mm (1.3 in.)
G1A	240 (177)	450 (332)	330 (243)	360 (266)	41.91 mm (1.7 in.)
G1 1/4A	290 (214)	540 (398)	420 (310)	540 (398)	47.80 mm (1.9 in.)

<b>With coarse-pitch thread. All torque values are in Nm (lb.-ft.) unless marked otherwise.</b>					
<b>Thread</b>	<b>Threads according to DIN 912, DIN 931, DIN 933, etc.</b>			<b>Threads according to DIN 7984</b>	
	<b>8.8</b>	<b>10.9</b>	<b>12.9</b>	<b>8.8</b>	<b>10.9</b>
M5	5.5 (4.1)	8 (6)	10 (7)	5 (4)	7 (5)
M6	10 (7)	14 (10)	17 (13)	8.5 (6.3)	12 (9)
M8	25 (18)	35 (26)	42 (31)	20 (15)	30 (22)
M10	45 (33)	65 (48)	80 (59)	40 (30)	59 (44)
M12	87 (64)	110 (81)	147 (108)	69 (51)	100 (74)
M14	135 (100)	180 (133)	230 (170)	110 (81)	160 (118)
M16	210 (155)	275 (203)	350 (258)	170 (125)	250 (184)
M18	280 (207)	410 (302)	480 (354)	245 (181)	345 (254)
M20	410 (302)	570 (420)	690 (509)	340 (251)	490 (361)
M22	550 (406)	780 (575)	930 (686)	460 (339)	660 (487)
M24	710 (524)	1000 (738)	1190 (878)	590 (435)	840 (620)
M27	1040 (767)	1480 (1092)	1770 (1305)	870 (642)	1250 (922)
M30	1420 (1047)	2010 (1482)	2400 (1770)	1200 (885)	1700 (1254)

<b>With fine-pitch thread. All torque values are in Nm (lb.-ft.) unless marked otherwise.</b>					
<b>Thread</b>	<b>Threads according to DIN 912, DIN 931, DIN 933, etc.</b>			<b>Threads according to DIN 7984</b>	
	<b>8.8</b>	<b>10.9</b>	<b>12.9</b>	<b>8.8</b>	<b>10.9</b>
M8X1.0	25 (18)	37 (27)	32 (43)	22 (16)	32 (24)
M10X1.0	50 (37)	75 (55)	88 (65)	43 (32)	65 (48)
M10X1.25	49 (36)	71 (52)	83 (61)	42 (31)	62 (46)
M12X1.25	87 (64)	130 (96)	150 (111)	75 (55)	110 (81)
M12X1.5	83 (61)	125 (92)	145 (107)	72 (53)	105 (77)
M14X1.5	135 (100)	200 (148)	173 (235)	120 (89)	175 (129)
M16X1.5	210 (155)	310 (229)	360 (266)	180 (133)	265 (195)
M18X1.5	315 (232)	450 (332)	530 (391)	270 (199)	385 (284)
M20X1.5	440 (325)	630 (465)	730 (538)	375 (277)	530 (391)
M22X1.5	590 (435)	840 (620)	980 (723)	500 (369)	710 (524)
M24X2.0	740 (546)	1070 (789)	1250 (922)	630 (465)	900 (664)
M27X2.0	1100 (811)	1550 (1143)	1800 (1328)	920 (679)	1300 (959)
M30X2.0	1500 (1106)	2150 (1586)	2500 (1844)	1300 (959)	1850 (1364)



For Support and Service, Contact Your Dealer



Manitou Group  
One Gehl Way, West Bend, WI 53095-0179 U.S.A.  
[www.us.manitou.com](http://www.us.manitou.com) / [www.mustangmfg.com](http://www.mustangmfg.com)

© 2021 All rights reserved