



SCHAF Newsletter for July 2024

Reminder: The next SCHAF Open House will take place Saturday, July 13, 2024, from 10am-1pm at Hangar Y-1 Jim Hamilton/LB Owens Airport.

Foundation Happenings

The June Open House was filled with parachutes hanging from the ceiling, displayed on tables, sitting in the plane, and even small, toy parachute men handed out to the young visitors. Ted set up his annual display showing the items used by the 82nd Airborne. Since the open house was just after June 6th, Bruce set up a display showing the units and items used on D-Day. This event was popular with both young and old.



Visitors to CUB

SCHAF was honored to host a drop in for FBO (Fixed Base Operators) from around the country. Eagle Aviation was the site of the annual event this year. They stopped by to visit our hangar and see our restoration progress prior to going to the Curtiss Wright Hangar for dinner.



Restoration Progress

The restoration crew removed another lower panel located directly behind the lower turret. It is amazing how different the plane looks by just standing in a new section. It gives you an entirely different perspective. This has opened a whole new world of research for this area of the plane. The picture on the left is looking toward the rear of the plane. The round circle on the floor is where the camera port was located. Just in front of the camera was the rear entrance hatch. Behind the camera was a chemical toilet. On the right is a picture from the B25C-D Illustrated Parts manual. Item #17 is a toilet paper roll holder. They thought of everything in this bomber!

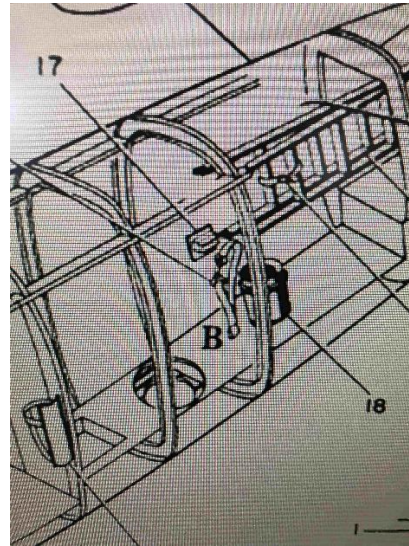

Shown below is the location of the reel unit for the Liaison Radio Trailing Antenna. On the right is the picture from the B-25C-D Maintenance Manual. "In order to retract and extend the trailing antenna for the liaison transmitting equipment, an antenna reel unit has been installed in the airplane."



Fig. 29 Liaison Radio Trailing Antenna

The picture on the left is the side frame of the rear hatch entrance. There is not much left of this entrance so it will have to be completely rebuilt. We love finding small tidbits in the plane. On the right is a picture of the cover for a dome light switch. This would have been painted black with the "DOME LGT." in white. While this part will be rebuilt, we will have this original piece in our display case.



Travels This Summer

Last month we asked readers to send along pictures of any airplanes you see during your summer travels. Here are a few more from John's visit to the National Museum of World War II Aviation in Colorado Springs. These are my two favorite planes. What is your favorite airplane?



SBD Dauntless

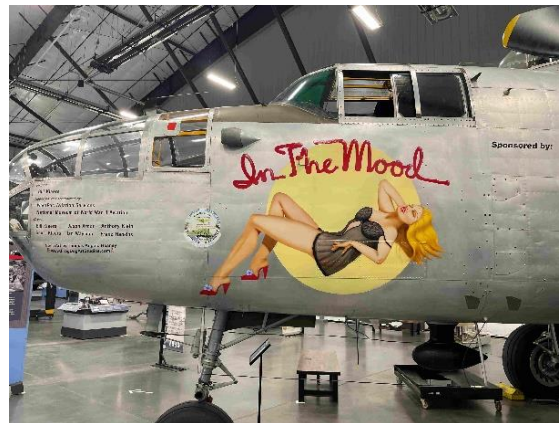

B-25 Mitchell

Planes Flying Overhead

Ken set up a great display of our donated P-38 model flying overhead. Our collection of wonderful models is growing. It is great to be able to display so many different planes.



Wrap Up

Eagle Aviation donated one of their scissor lifts to SCHAF. This will be instrumental in helping us work on the outside of GF2. Unfortunately, I forgot to get a picture of it before we wrapped it tight in a tarp. This is currently behind the hangar until we get a spot cleared inside the hangar. We have certainly outgrown our current space.



If you have something you would like to share in a future newsletter or if you have any questions, please send an email directly to SCHAF at info.schaf@gmail.com.

South Carolina Historic Aviation Foundation 803 731 3254
3100 Devine St, Columbia, SC 29205
www.schistoricaviation.org

