

Rio Dell Wildwood Days Rib Cook Off

Thursday July 30th, 2026

Rules and Regulations

1. Health and Safety – Health concerns are of primary importance. Cooking areas shall comply with applicable health requirements. The Humboldt County Dept. of Public Health, division of Environmental health guidelines for a temporary food booth, will be added with packet. Health regulations are enforced and may be inspected by the coordinator.
 - a. It's **not** necessary to obtain a permit with Public Health. The event coordinator has obtained the permit.
 - b. Each team shall provide the mandatory 3 compartment wash, rinse, sanitize set up. (info on last page)
 - c. All teams are expected to maintain their cooking sites in an orderly and clean manner and use good sanitary practices.

2. Equipment and approved cookers – Any wood, charcoal, or wood pellet fired cookers (homemade or commercially manufactured) will be allowed. Electric or manually operated rotisseries or rotating shelves, augers, or draft devices are permitted during cooking process.
 - a. Props, trailers, tents/canopies, equipment shall not exceed the boundaries permitted.

- b. No Pits, “holes” or ground fire devices shall be permitted.
 - c. NO SHARING OF COOKING SOURCES! Two teams cannot share the same fire source.

- 3. Supplies – Teams must provide all its own supplies. Event coordinators will provide meat, judging trays, people’s choice buckets. No electricity or water will be supplied.
 - a. EACH TEAM SHALL HAVE AN ABC FIRE EXTINGUISHER
 - b. Each team shall have a meat thermometer and follow internal meat temperature guidelines.
 - c. People handling meat will have to wear sanitary gloves.

- 4. The event coordinator will provide all the ribs necessary for the competition. (NO OFF-SITE MEATS ARE ALLOWED) and judging boxes. Once you get your ribs, they are not allowed to leave your space until judging.

- 5. Judging/Scoring – Each team will be given a secret number that will correlate with the number on the bottom of your judged box. This will be blind judging with pre-selected judges on a 10-point scale per category. Presentation, Taste/flavor and Tenderness/texture. With a max of 30 points possible. There will also be a people’s choice winner that will be selected by having the greatest number of tickets in your bucket.

6. Times –

- a. Set up time (be on the street, cars off and ready to start) at 9-10am
- b. Chef and coordinator meeting 10:15am to be given secret numbers and ribs (can light fires at this point)
- c. Turn in time to judges 5:30pm will be given a 10-minute window for time no more than 5 minutes before time or 5 minutes after time.
- d. People's Choice tastings will be as soon as you deliver to judges 5:30 to 6:30pm
- e. Awards: 7pm
- f. Clean up and off the streets: 8pm

7. Disqualifications –

- a. Failure to wear sanitary gloves while handling meat, not following sanitary procedures during prep, cooking, judging processes.
- b. The evidence of marking or sculpting judging boxes.
- c. Improperly cooked meats.
- d. Excessive use of alcoholic beverages or public intoxication with disturbance.
- e. Foul, abusive or unacceptable language or any language causing a disturbance.
- f. Fighting or disorderly conduct.
- g. Theft, dishonesty, cheating or use of prohibited meats.

Head Chef Name: _____

Team Name: _____

By signing this form, I understand all the rules and regulations. I also understand that the Wildwood Days committee, City of Rio Dell and/or event coordinator putting on this event are not responsible for loss, damage, personal injury, or theft while on premises of this event. I agree to fully clean my booth area and make sure it's clear of any debris before I leave this event. I understand that I may be held responsible and liable for any damage I or anyone associated with my booth may cause to the area.

Head Chef
Signature _____

Date: _____

Event Coordinator
signature _____

Date: _____

Event Coordinator: Mavis Amen 707-460-0365

Temporary Food Facility Booth

Taken from the Humboldt County Health & Human Services booklet. For more information contact the Environmental Health Department at (707) 445-6215.

- Provide a fully enclosed booth with a roof and walls to prevent food contamination.
- Provide a hand washing station (water dispenser above a 5-gallon bucket, with soap in a dispenser and paper towels).
- Store all food at least 6" above the ground & protect food with covers or lids.
- Properly dispose of wastewater in the gray water tank provided by the event organizers, not on the ground! The gray water tank will be located next to the porta potties on 11th Street.
- All cooked chili must be heated to 165° and held at 135° or above and checked with a metal stem thermometer. All cold food must be kept below 45°.
- No smoking, vaping, eating, or drinking in the booth.
- No live animals.
- Store all garbage in plastic garbage bags or leak-proof cans and put in the dumpsters provided, not the event garbage cans.

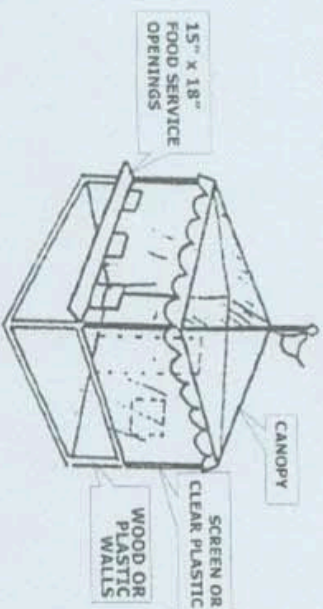
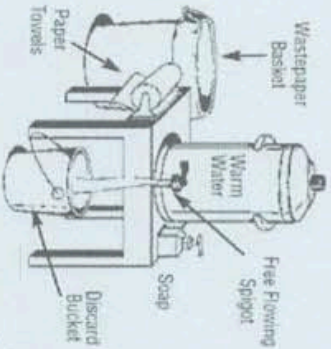

**EXAMPLE OF
A FOOD BOOTH**