



BIGMAX Cranes

TC Series Compact Telescopic Mono-Boom Cranes



CHOICE

- 20 models from 6,700 to 25,000 ft. lbs.
- Hydraulic extensions to 19.5 feet
- Compact design requires less mounting/stowage space
- Powered by PTO pump or truck battery
- Range of outrigger stabilizers

STRENGTH

- High tensile steel construction
- Designed for low weight and maximum lift
- Cast steel base with oil bath slewing gears
- Two-year limited warranty

SAFETY

- Active and passive overload protection
- Counterbalance safety valve flangemounted to main cylinder
- In-cab power shutoff switch on
- DC models
- Complies with ANSI B 30.5, DIN 15018 and EN12999 Standards

TC Series Reach and Load Chart

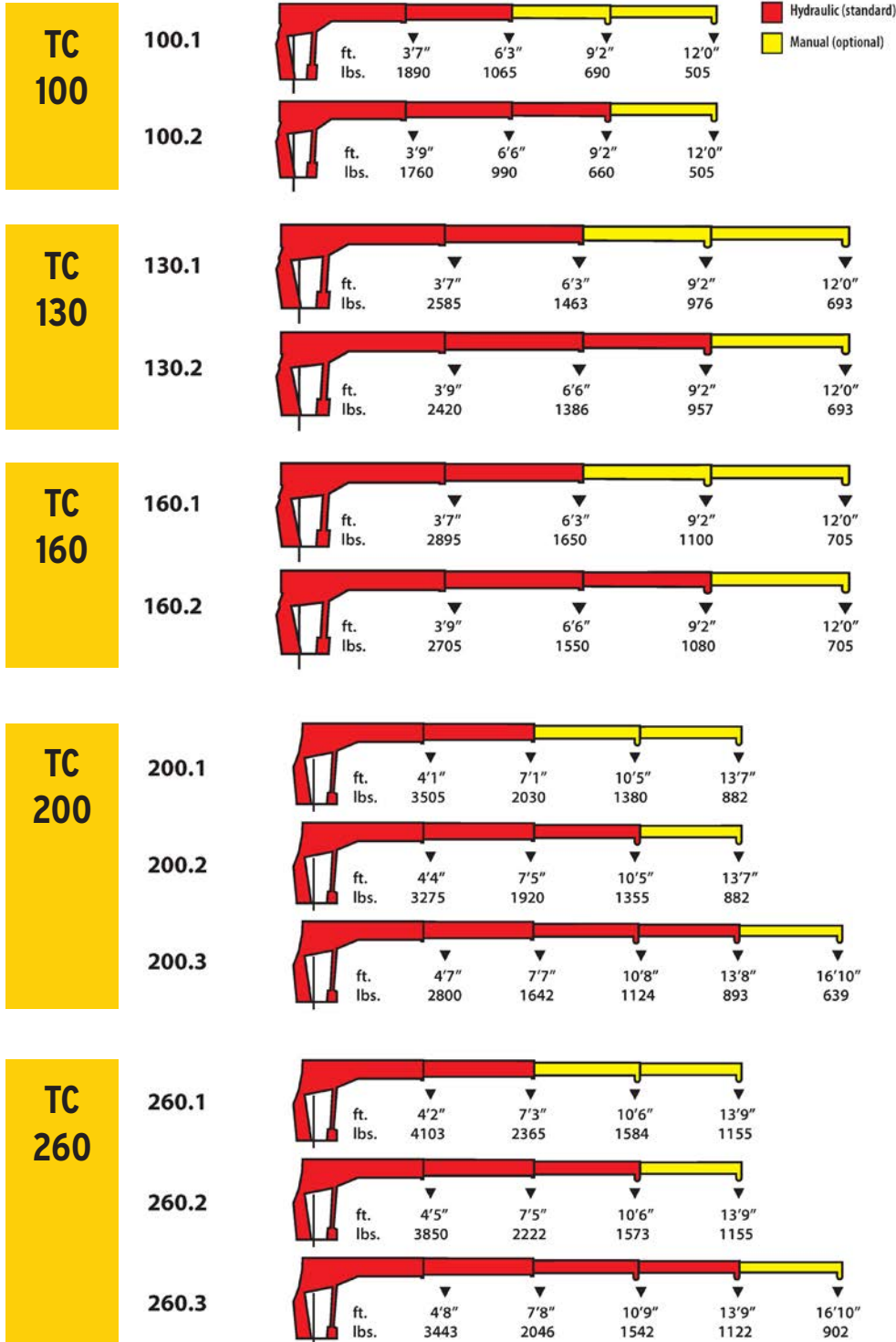

Dimensions (inches)

MODEL	A	B	C
TC 100	24.6	48.8	11.8
TC 130	31.3	48.9	12.2
TC 160	31.3	48.9	12.2
TC 200	32.0	59.1	11.8
TC 260	33.9	63.0	11.8
TC 300	33.9	63.0	11.8
TC 350	41.0	67.0	13.0

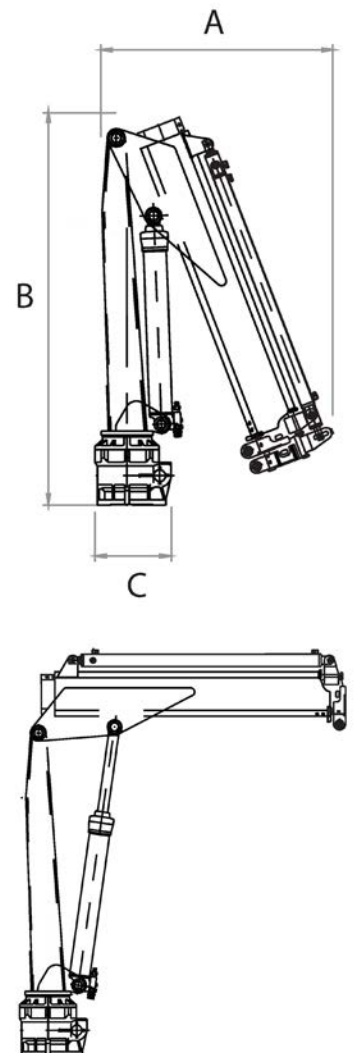

TC Series Reach and Load Chart

**TC
300**

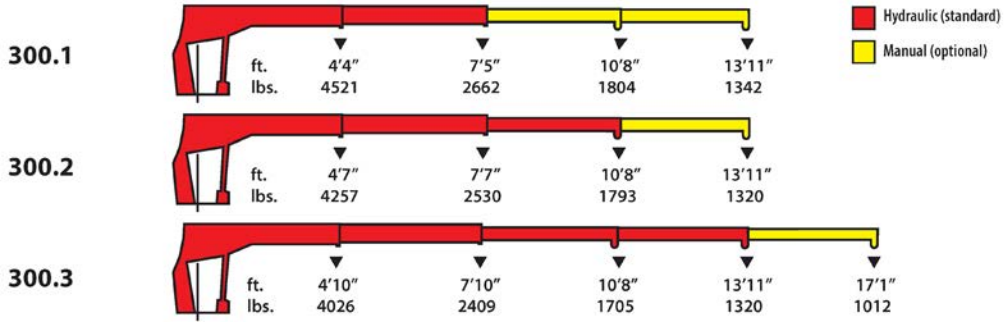

**TC
350**

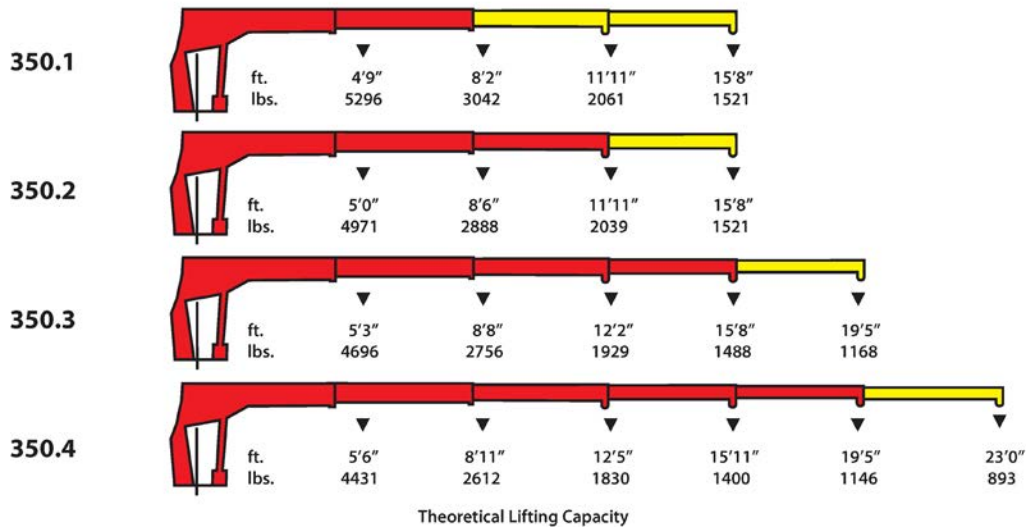

TC CRANE WITH WINCH

TC 100 and TC 130 cranes are available with a heel mounted 800 lb. winch.

TC cranes are designed to lift material such as waste bags vertically, close to the column.

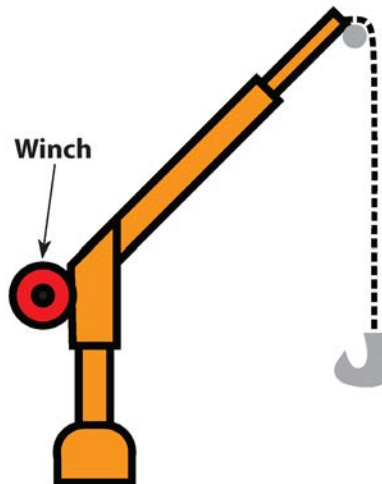

CRANE OPTIONS

1. POWER PACK: 12 and 24V DC power packs are available when a PTO pump is not available.

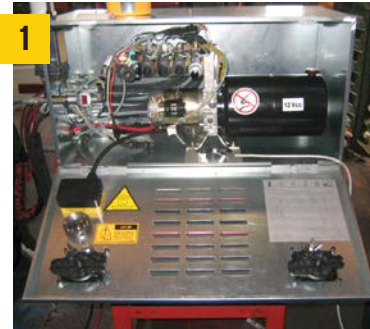

2. CRANE MOUNTING BASE: To mount the crane directly to the truck frame.

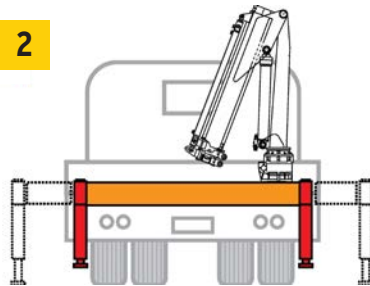

3. WINCH: A winch can be installed on most TC models to increase vertical lift capability. Winches are standard on TC cranes.



4. WIRELESS CONTROLS: Hand held, wireless controls are available for enhanced safety and convenience.

5. ACCESSORIES: Rotators, grabs and augers are available for most TC models.



6. OUTRIGGER STABILIZERS: Are available for all TC Series cranes.



TC Series Compact Telescopic Mono-Boom Cranes

Specifications Table

MODEL	MAXIMUM LIFT	LIFT MOMENT (FT. LBS.)	MAXIMUM REACH	BASE CRANE WEIGHT (LBS.)
TC 100	1,890 lbs	6,710	12'	277-332
TC 130	2,585 lbs	8,800	12'	341-396
TC 160	2,895 lbs	10,250	12'	341-396
TC 200	3,505 lbs	14,430	16'10"	417-530
TC 260	4,103 lbs	17,175	16'10"	497-601
TC 300	4,521 lbs	19,850	17'1"	521-653
TC 350	5,296 lbs	24,900	23'	650-860