

TCA-700

TCA-700 (6.6 TM CLASS)

- Lifting moment: 6.58 tm
- Max. vert. reach: 8.3 m
- Slewing angle: 387°
- Slewing time: 15 s/180°
- Max. working heel: 4°
- Working pressure: 245 bar
- Crane w/o stab.: 800 kg
- Weight of stab.: 35 kg
- Oil tank capacity: 35 l
- Oil flow: 20 l/min
- Dim.: 2240x1980x600 mm
- Sug. truck: min. GVW 5 ton

STANDARD

- Dual controls
- Load limiting device (CE)
- Hexagonal section extensions
- Independent extension cylinders
- Fixed stabilizer cylinder
- Flanged valves
- Oil Tank
- Assembly kit
- Designed in accordance with: EN12999 – DIN15018
- Fatigue test classification: B3

OPTIONAL

- Pivoting stabilizer legs
- Outriggers with hydraulic extension
- Manual extensions
- Supplementary elements activation
- Winch
- Extra extensible stabilizers
- Outriggers with hydraulic extensions

TCA-700

TECHNICAL DATA

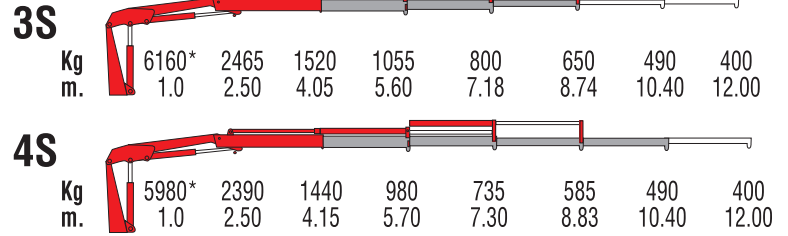
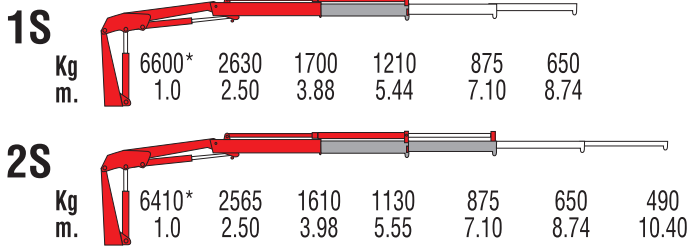

*) Theoretical lifting capacity

MODELS	Lifting Moment lb.ft	Max Vertical Reach (Hydr) ft-in	Working Pressure psi	Oil Flow gal/min	Slewing Angle °	Weight lb	Dimensions (WxHxD) inches
1S	47700	27' 4"	3550	5,3	387	1980	88x77x24
2S	-	32' 2"	3550	5,3	387	2140	88x77x24

MODELS	Lifting Moment lb.ft	Max Vertical Reach (Hydr) ft-in	Working Pressure psi	Oil Flow gal/min	Slewing Angle °	Weight lb	Dimensions (WxHxD) inches
3S	-	37' 2"	3550	5,3	387	2270	88x77x24
4S	-	42' 4"	3550	5,3	387	2380	88x77x24

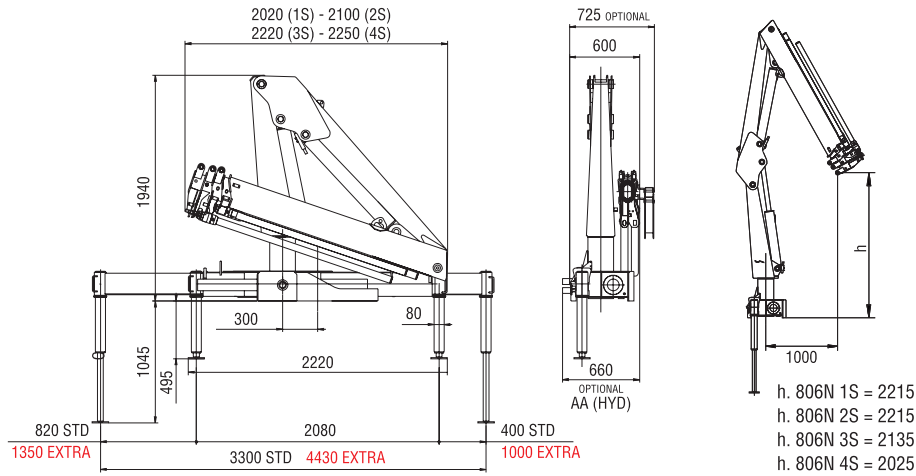

MAX. LIFTING MOMENT	MAX VERTICAL REACH				SLEWING ANGLE	SLEWING SPEED	MAX WORKING HEEL
	1s	2s	3s	4s			

6.6 (t.m.)	hyd.	8.4m	10.0m	11.6m	400°	15 s	4° (8%)
	man.	11.6m	13.2m	14.8m			

WORKING PRESSURE	CRANE WEIGHT WITHOUT STABILIZERS				WEIGHT OF STABILIZERS	OIL TANK CAPACITY	OIL FLOW TO THE DISTRIBUTOR BOX
	1s	2s	3s	4s			

250 bar	800 kg	870 kg	930 kg	980 kg	100 Std.	35 l	20 l/min
					145 Ext.		

ACCESORIES

- Turning stabilizer legs
- Supplementary elements activation
- Winch*
- Extra extensible stabilizers
- Radio-Remote control
- Outriggers with hydraulic extension

*Jo.st

RECOMMENDED TRUCK
WHEELBASE: 3105 mm
M.T.T. ton 7,5
G.V.W. ton 7,5

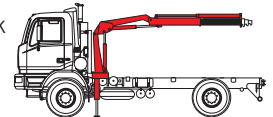

1465-259 Street Acheson AB T7X 6C4 Canada

SALES & GENERAL INQUIRY & DISTRIBUTION

1-800-661-7335 or 780-960-6826

bigmaxsales@driveproducts.com

To learn more about Drive Products visit

www.driveproducts.com

BIGMAX®

BY DRIVE PRODUCTS

bigmaxproducts.com