



BIGMAX[®]

BY DRIVE PRODUCTS

OUTRIGGER STABILIZERS

BIGMAX Outrigger Type C and X

Type C and X

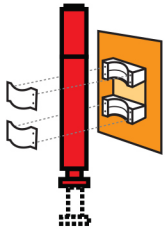

Stabilizer Leg Only (Type C)

This single outrigger leg (no cross beam) has an adjustable mounting flange and pilot-operated lock valve. It is available in six sizes to be used with cranes ranging in size from 2 to 120 t/m. The leg is available in the adjustable, non-adjustable or tilt up options. The Type C outrigger is of particular interest to OEMs as it is most commonly used when only one leg is attached to a custom designed beam such as for post drivers, trailers, ditchers and for use as a landing leg.

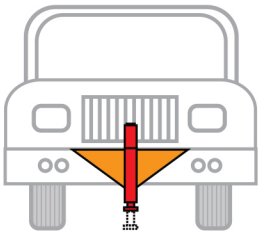

Front Bumper Stabilizer (Type X)

This front bumper mounted single outrigger leg is available in six sizes and is supplied with an adjustable mounting flange and pilot-operated lock valve. It is designed to be used with cranes ranging in size from 2 to 120 t/m. This type is most commonly used on boom trucks or cabover trucks to provide additional stability, and is often mounted with custom made brackets.



Continued on next page



www.driveproducts.com

BIGMAX by Drive Products

Toll free: 800-661-7335 | jvehse@driveproducts.com

Type C full unit

Note: Ratings below are for auxiliary outrigger stabilizers only. For basic information required to select primary (main) stabilizers, see How To Select Outriggers below.

SERIES	MAX. LOAD FACTOR (DAN)	MAIN DIMENSIONS mm					
		AxB	CV	ØP	ØE1	ØS	H
0A - 0/S-CR	2950	180x140	355	160	75	40	530
1/S-CR	6250	210x140	455	160	90	60	685
1/L-CR	6250	210x160	580	160	90	60	810
2/C-CR	8250	240x170	470	200	100	60	700
2/S-CR	8250	240x170	550	200	100	60	780
2/L-CR	8250	240x170	635	200	100	60	865
3/C-CR	10,450	240x170	470	200	100	60	750
3/S-CR	10,450	240x170	550	200	100	60	830
3/L-CR	10,450	240x170	635	200	100	60	915
4/C-CR	12,700	270x220	565	200	110	70	850
4/C-SR	12,700	270x220	735	200	110	70	1010
5/C-CR	17,700	360x200	460	200	120	90	850
5/L-CR	17,700	360x200	610	200	120	90	1000
6/C-CR	20,500	280x200	460	200	120	90	850
6/L-CR	20,500	280x200	610	200	120	90	1000
7/C-CR	25,000	300x235	470	180	140	100	860
7/L-CR	25,000	300x235	610	180	140	100	1000

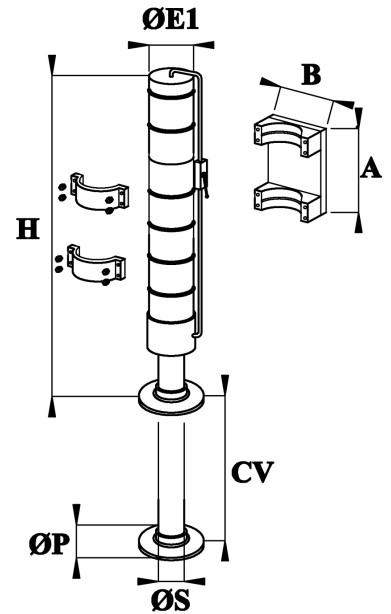

How to Select Outriggers

A safe lift begins with choosing the right crane and outriggers for the job. The main function of outriggers, also known as 'stabilizers', is to keep a truck and crane unit stable while in work mode. This can generally be accomplished with a single set of outriggers. In some cases, adding a second set of outriggers can create a more stable platform for loading and unloading materials. This additional support minimizes shifting and leaning creating much less stress on the equipment and the crane operator.

Another important benefit of auxiliary outriggers is the reduced wear and tear on the crane rotation system due to limited side loading. Studies have pointed to the additional repair cost and loss of productivity resulting from operating cranes without adequate outriggers.