

# California Air Tools

## 5 Gallon Pressure Pot with HVLP Spray Gun and Hose

Model No. 365



### Technical Data

Type of feed.....	Pressure
Maximum pressure in the tank.....	80 PSI
Working pressure in the tank.....	60 PSI
Working pressure in the Spray Gun.....	35-45PSI
Air consumption.....	8.5 CFM
Nozzle Size.....	1.4mm
Air Hose.....	1/4" 33 ft
Fluid Hose.....	3/4" 33 ft
Tank capacity.....	5 Gallon

## Safety Guidelines- Definitions

### **NOTE!**

Information that you should pay special attention to.

### **DANGER!**

URGENT SAFETY INFORMATION

A HAZARD THAT WILL CAUSE SERIOUS INJURY OR LOSS OF LIFE

### **CAUTION!**

Information for preventing damage to equipment

### **WARNING!**

IMPORTANT SAFETY INFORMATION

A HAZARD THAT *MIGHT* CAUSE SERIOUS INJURY OR LOSS OF LIFE

## Important Safety Instructions

### Save These Instructions

IMPROPER OPERATION OR MAINTENANCE OF THIS PRODUCT COULD RESULT IN SERIOUS INJURY AND PROPERTY DAMAGE. READ AND UNDERSTAND ALL WARNING AND OPERATING INSTRUCTIONS BEFORE USING EQUIPMENT.

### **Over pressurization of Attachments**

Hazard	What Could Happen	How To Prevent It
<b>WARNING!</b> Explosion of objects	Attachments whose pressure rating is lower than the adjusted pressure in the tank could explode, resulting in serious injury or property damage.	Always make sure that equipment connected to tank has a higher pressure rating than the regulated air pressure tank

### **WARNING!**

When performing maintenance disconnect the air line.

If for any reason it is required to replace any parts, it is recommended to replace part with original parts.

Never operate equipment while under the influence of alcohol or drugs. If you have signs of exhaustion stop usage, it may cause an accident

### **Caution!**

This pressure tank is not designed for highly abrasive or corrosive applications. If used with such materials, frequent and thorough cleaning is advised to reduce excess wear and repair issues.

## Assembly

### Read the instructions carefully

Read instructions carefully before using this product. This equipment can be used to supply material up to 60 pounds (PSI). This equipment has an agitator, air regulator, pressure gauge, safety valve and outlet for the material. The tank has been coated to last. The agitator allows you to maintain the uniformity of the material before being applied as long as the material is not too heavy.

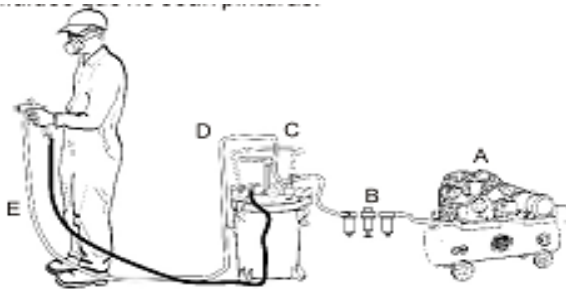

The picture above illustrates the best set up and operation of this equipment.

### Important Notes

This picture is only for the purpose of illustration, the filter "B", the compressor "A" and operator safety equipment are all sold separately.

This product is subject to slight changes as to what is presented in this owner's manual. Without notice in both changes in design and parts can occur in order to better increase the performance of the product.

### Air Compressor

Use an air compressor that can produce at less 90 PSI.

1. **WARNING!** Ensure the air supply is clean and does not exceed 90psi while operating the tool.  
Too high air pressure and unclean air will shorten the product life due to excessive wear, and may be dangerous causing damage or personal injury.
2. Drain the air compressor air tank daily. Water in the air line will damage the tool.
3. Clean air inlet air filter weekly.
4. The air hose should not be longer than 50ft.  
The minimum hose diameter should be 1/4" I.D. and fittings must have the same inside dimensions.
5. Keep hose away from heat, oil and sharp edges. Check hose for wear and make certain that all connections are secure.

### Assembly Instructions

1. Install the regulator assembly to the swivel adaptor on the tank lid.  
Check the bottom of regulator for location of tank connection
2. Install the handle in the treaded hole in the center of the tank lid. Tighten hex nut.
3. Connect the air hose to the air inlet fitting on tank regulator. (Right or left optional)
4. Connect fluid hose to the fluid outlet fitting located on the tank lid.

## **Instructions for using Air Pressure Regulator on Paint Tank**

### **Purpose of Pressure Regulator**

The pressure regulator on the paint pot regulates the amount of pressure applied to the paint in the paint tank. This controls the pressure of the paint being delivered to the spray gun.

### **Recommended Paint Tank Pressure**

**Internal-Mix Guns-** Use higher tank pressure up to the full amount of air pressure being delivered to the spray gun. Never exceed 60 PSI at the spray gun or paint tank

**External-Mix Guns-** Use lower tanks pressures. Always start with pressure in paint tank at “zero” and increase pressure in tank gradually until spray pattern is obtained.

**Important:** Before turning on air pressure, screw out the regulator T-handle adjusting screw all the way counter-clockwise, to shut off the air pressure. Turn on the air, and then adjust the regulator to the required pressure. Do not use over 60 PSI pressure in the paint tank. Part of the air from air compressor or air line by passes regulator through the “T” fitting and the spray gun.

### **Operating the Pressure Pot for Paint**

You are now ready to fill the tank with material. Before doing so be sure to thoroughly mix and strain the paint to remove skins or not dissolved particles which might otherwise impede the flow of material through the hose and gun

A one gallon can of paint be set inside the tank instead of pouring the paint into the tanks.

Place lid assembly on tank and hand tighten tank lid clamp screw

Shut off paint regulator by turning T-handle counter-clockwise. Adjust the compressor regulator to obtain to obtain the desired air pressure on the spray gun.

Now adjust the regulator on the paint tank to obtain the desired air pressure for the material. The higher above the paint tank you are spraying the more pressure you will need on the material. Normal operating pressure on the paint tank is 25 to 60 PSI. Should you wish to reduce pressure, simply rotate T-handle adjusting screw counter-clockwise until desired pressure setting is obtained. There is no need to trigger the gun in order to bleed off excess paint pressure.

### **WARNING!**

Do not use over 80 PSI air pressure in your tank.

### **Operation**

1. Open the compressor's valve or turn it on
2. Turn the regulator knob clockwise to increase the pressure material. Turn it counter-clockwise to decrease pressure. The maximum tank pressure is 80 PSI.
3. The spray gun is adjustable by means of a valve adjustment or air regulator
4. Before using the gun make sure that all connections are tightened properly check that the air gun works with air, also check that neither gun nor hose have dirt or impurities
5. Connect the materials hose to coupling A and the air hose to coupling B.
6. Adjust the required size range; completely closing the lead screw, which is located on the side of the gun, and opening it slowly until it reaches the desired array pattern.
7. Adjust the amount of material applied by completely closing the lead screw, which is located in the rear, and opening it slowly until it reaches the desired amount of material.
8. Always paint at a uniform distance (15 to 30 cm) and parallel to the surface you are applying the material to.

## **Maintenance and Storage**

1. Close the air flow to the equipment.
2. Release all air pressure in the tank by pulling the safety valve ring until the pressure subsides.
3. Rotate the tank regulator handle "T" counter clockwise until you do not feel any tension in the spring.
4. Loosen the metal screws, remove the wing nuts, and open the lid to one side.
5. Loosen the metal rings on the gun nozzle about three turns.
6. Open the air supply.
7. Place a cloth or rag onto the mouthpiece like a receptacle and cover, and then pull the trigger. This action will force the remaining material in the hose to go back into the tank.
8. Empty and clean the tank and parts that have been in contact with the material by using a solvent recommended by the manufacturer.
9. Pour some solvent into the tank.
10. Place the lid and the wing nuts and tighten the thumbscrews.
11. Trigger the gun until the solvent comes out clean.
12. Repeat steps 4 to 7

## **Cleaning Instructions**

### **WARNING!**

**Always shut off air pressure at the source and bleed off all pressure in the Paint Tank by gently pulling the safety valve ring before loosening thumb screw and clamps remove lid.**

It is very important that the tank, material hose, and spray gun be cleaned as soon as spray job is finished. Turn off the main air supply to the tank. Remove all pressure from the tank by pulling the ring on the safety valve until the pressure bleeds down. Turn the T-handle adjusting screw on the regulator counter-clockwise until no spring tension is felt. Loosen thumb screws, tip clamps back and tip the tank lid to one side. Loosen spray gun air cap retaining ring about three turns then turn on the air supply. Cup cloth over air cap on the gun and pull the trigger. This will force the material back through the hose, into the tank. Empty and clean tank and parts which come in contact with the material. Use a suitable solvent. Pour solvent into the tank. Replace the lid and tighten the thumb screws and clamps and spray until clean appears.

# Trouble Shooting

## **WARNING:**

If any of the following symptoms appears during your operating, **stop** using the tool immediately, or serious personal injury could result.

Only a qualified persons or an authorized service center can perform repairs or replacement of tool.

Disconnect tool from air supply before attempting repair or adjustment. When replacing O-rings or Cylinder, lubricate with air tool oil before assembly.

<b>PROBLEMS</b>	<b>POSSIBLE CAUSES</b>	<b>CORRECTION</b>
Air escaping from port on regulator cap	Broken or damaged diaphragm in regulator.	Replace regulator
Pressure dropping slowly on gauge.	Dirty or work valve seat in regulator.	Replace regulator
Fluid or air leak at the lid gasket.	Defective lid gasket. Thumb screw not tight.	Replace lid gasket. Tighten thumb screws.
Paint in tank tends to settle rapidly.	Paint not mixed or thinned properly.	Mix or thin paint according to instruction on paint.
Gauge not registering air pressure.	Defective air gauge.	Replace air gauge
Safety valve popping off.	Tank pressure to high. Defective valve.	Reduce tank pressure to 20-50 PSI. Replace safety valve.
Note: Repairs should be carried out by a qualified person.		

## Parts Reference

ITEM	DESC.
1	SAFETY VALVE
2	SCREW
3	AIR RELEASE VALVE
4	PRESSURE GAUGE
5	TANK CAP
6	TANK SIDE HANDLE BAR
7	CAP HANDLE BAR
8	ELBOW CONNECTOR
9	INLET VALVE
10	ALUMINIUM 4-PORT CONNECTOR
11	INLET CONNECTOR S16
12	PAGODA CONNECTOR
13	G1/4 BALL VALVE
14	PRESSURE REGULATOR KIT
15	WING NUT M16
16	WASHER M16
17	CAP SIDE BRACKET
18	BOLT M16
19	PIN $\phi$ 12
20	TANK SIDE BRACKET
21	TANK
22	FOOT BRACKET
23	CASTER WHEEL
24	MIXING BAR
25	HAND CRANK
26	ROCKING BAR
27	CONNECTING SLEEVE
28	HEX SCREW M36
29	HEX NUT M36
30	IMPELLER
31	BALL VALVE G3/8"
32	ALUMINIUM ELBOW
33	SUCTION TUBE
34	FILTER

# EXPLOSIVE DRAWING OF 365

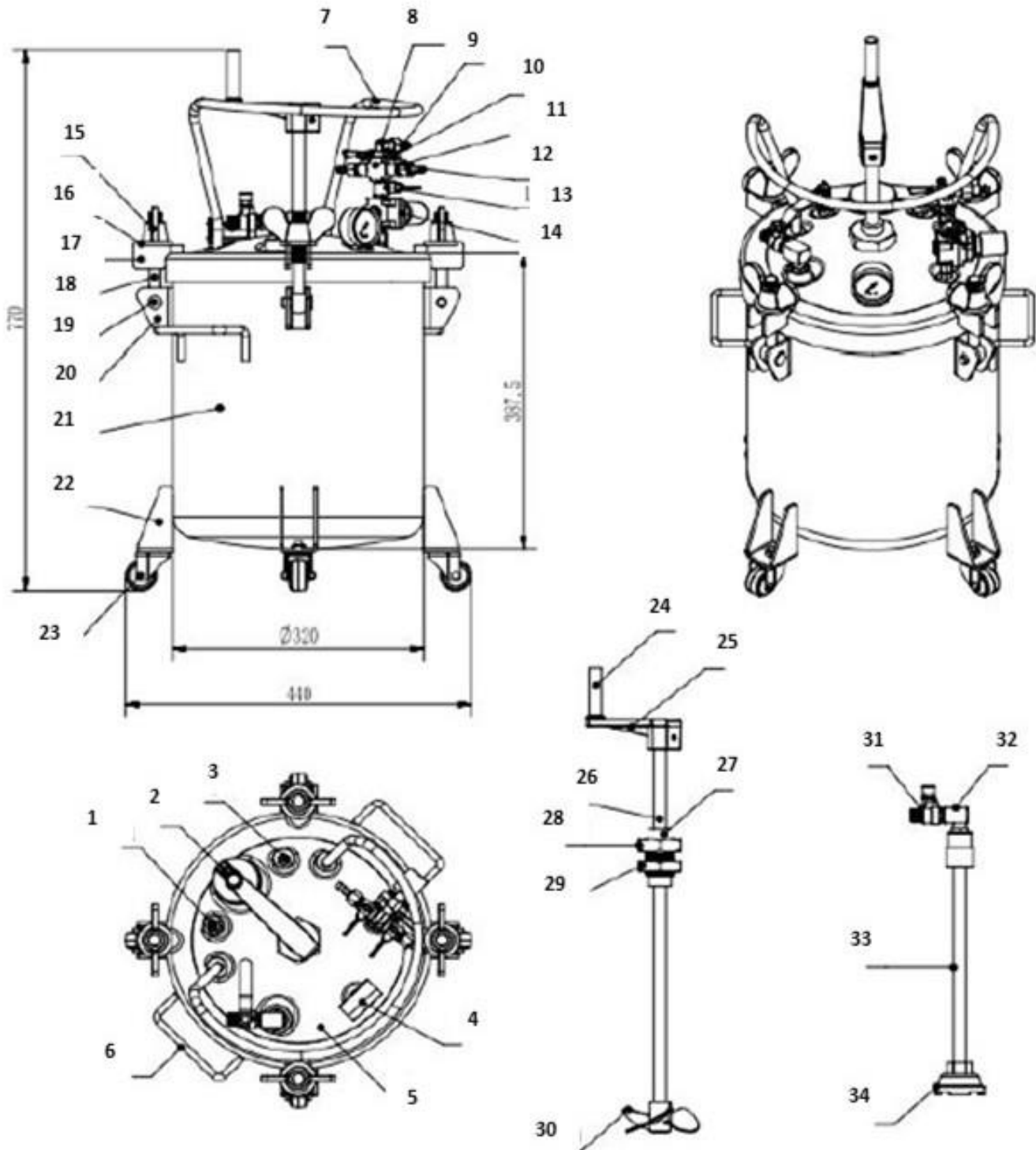



# Limited Warranty

This Warranty is Limited to *CALIFORNIA AIR TOOLS* and *SPRAYIT* Products.

**Limited Warranty: 1 Year**

*CALIFORNIA AIR TOOLS, Inc.* will repair or replace, free of charge, to the original retail customer whom purchased a *CALIFORNIA AIR TOOLS* or *SPRAYIT* product from an authorized dealer, distributor or distributor's dealer.

This warranty does not transfer to subsequent owners.

*CALIFORNIA AIR TOOLS, Inc.* will repair or replace, at its option, any parts that are proven by an authorized service center to be defective in material or workmanship under normal use during the applicable warranty time period as stated above.

This limited warranty covers the cost of the replacement parts and labor for all defects when installed by an authorized service center.

Transportation charges are the responsibility of the customer.

Any part replaced under warranty becomes the property of *CALIFORNIA AIR TOOL, Inc.*

All parts replaced under warranty will be considered as part of the original product, and any warranty on those parts will expire coincident with the original product warranty.

The limited warranty period begins on the date of the retail purchase by the original purchaser.

*CALIFORNIA AIR TOOL, Inc.*  
8560 Siempre Viva Road  
San Diego, California 92154  
Tel: (866) 409-4581  
Fax (619) 424-8697  
[info@CALIFORNIAAIRTOOLS.com](mailto:info@CALIFORNIAAIRTOOLS.com)

[www.CALIFORNIAAIRTOOLS.com](http://www.CALIFORNIAAIRTOOLS.com)