

DC Axial Fan

80mm x 80mm x 25mm
RoHS Certified

G3CNC

HD8025U24B



Electrical Properties

Rated Voltage	24V DC
Rated Current	65mA / Max. 75mA
Rated Power Consumption	1.56W / Max. 1.80W
Safety Power Consumption	1.68W
Operating Voltage Range	12 to 27.6V DC
Starting Voltage	8V DC (25°C Power ON/OFF)
Operating Temperature Range	-10°C to +70°C
Storage Temperature Range	-40°C to +70°C

Mechanical Properties

Motor Design	Single Phase, 4-Pole Brushless DC Motor
Bearing System	Ball Bearing
Power Connection Type	#24AWG - 2 Lead Wires; Red (+), Black (-)
Frame Material	Thermoplastic PBT of UL 94V-0
Fan Blade Material	Thermoplastic PBT of UL 94V-0
Rotation Direction	Counter-Clockwise (Viewed from Front of Fan Blade)
Mounting Holes	4.3mm Diameter, 8 Holes
Weight	75g

Performance Properties

Rated Speed	4800 RPM \pm 10% @ Rated Voltage
Air Flow	68.0 CFM
Static Pressure	11.37mm -H ₂ O
Acoustic Noise	38.0 dB (A)
Insulation Class	UL Class A

Insulation Resistance	10MΩ @ 500V DC between internal stator & lead Wire (+)
Dielectric Strength	Applied AC 500V for one minute or AC 600V for 2 Seconds between housing & lead Wire (+)
Life Expectancy	60,000 Hours @ 40°C, 65% Humidity, 90% CL.
Protection	Automatic Restart Note: In a situation where the fan is locked by an external force while The electricity is on, an increase in coil temperature will be prevented by temporarily turning off the electrical power to the motor. The fan will automatically restart when the locked rotor condition is release. Polarity Protection

DC Axial Fan

80mm x 80mm x 25mm

DIMENSIONS DRAWING

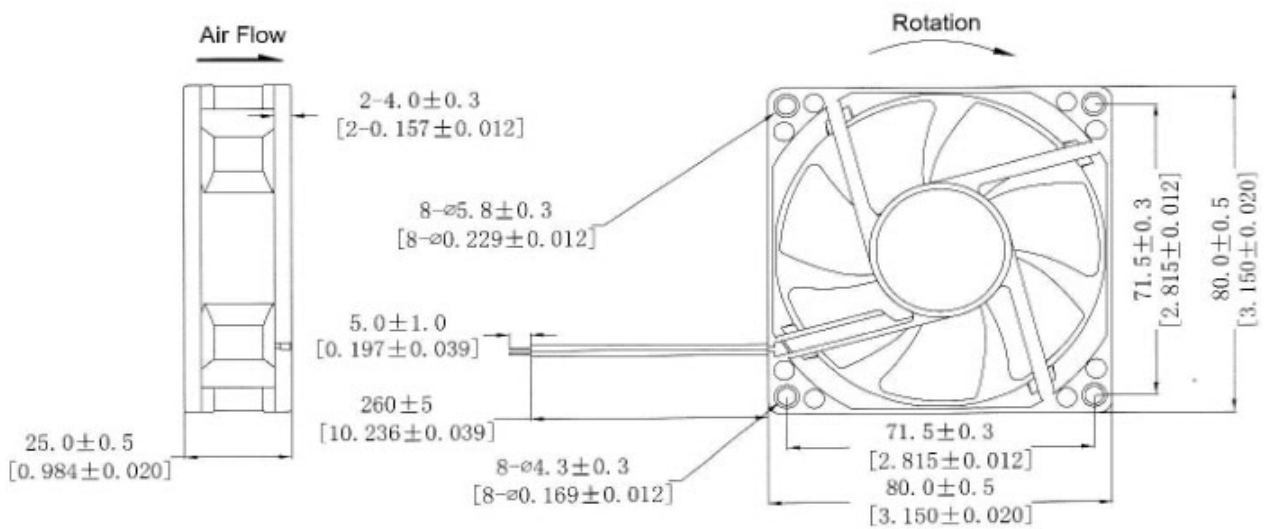

UNIT: $\frac{\text{mm}}{[\text{inch}]}$