

G3 CNC

2 Phase Hybrid Stepper Motor

Model No.	Step Angle (°)	Rated Voltage (V)	Rated Current (A)	Phase Resistance (Ω)	Phase Inductance (mH)	Holding Torque (Kg.cm)	Detent Torque (g.cm Max)	Rotor Inertia (g.cm ²)	Motor Length (mm)	Leads No.	Motor Weight (Kg)
57ST115-4204A	1.8	3.2	3.5	0.9	2.5	32	14	1200	100	4	1.6

Dimensions

unit=mm

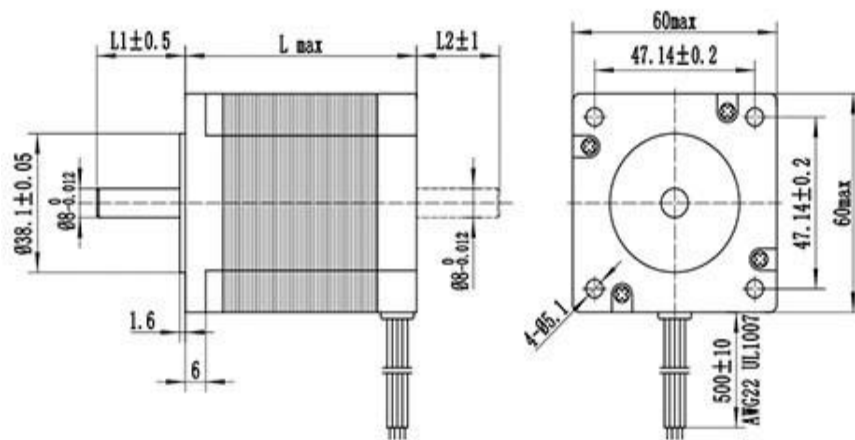

Wiring Diagram:

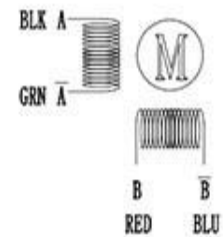

4 Leads

L1 and L2 can be customized according to customers' requirements.