

## G3 CNC

### 2 Phase Hybrid Stepper Motor

Model No.	Step Angle (°)	Rated Voltage (V)	Rated Current (A)	Phase Resistance (Ω)	Phase Inductance (mH)	Holding Torque (N.M)	Detent Torque (g.cm Max)	Rotor Inertia (g.cm <sup>2</sup> )	Motor Length (mm)	Leads No.	Motor Weight (Kg)
60HS100-4004A08	1.8	3.2	4.0	0.9	2.5	4	14	1200	100	4	1.6

#### Dimensions

unit=mm

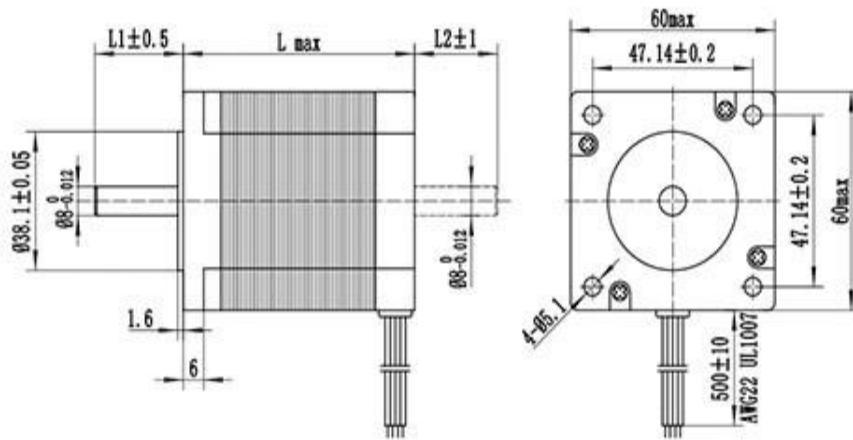

#### Wiring Diagram:

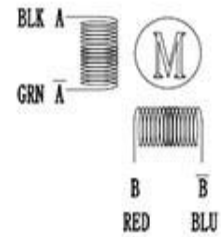

4 Leads

L1 and L2 can be customized according to customers' requirements.