

# FOCP-1

Fiber Optic Polisher



## Instruction Booklet

**NANOMETER TECHNOLOGIES**

[www.nanometer.com](http://www.nanometer.com)

# FOCP-1 Diagram View

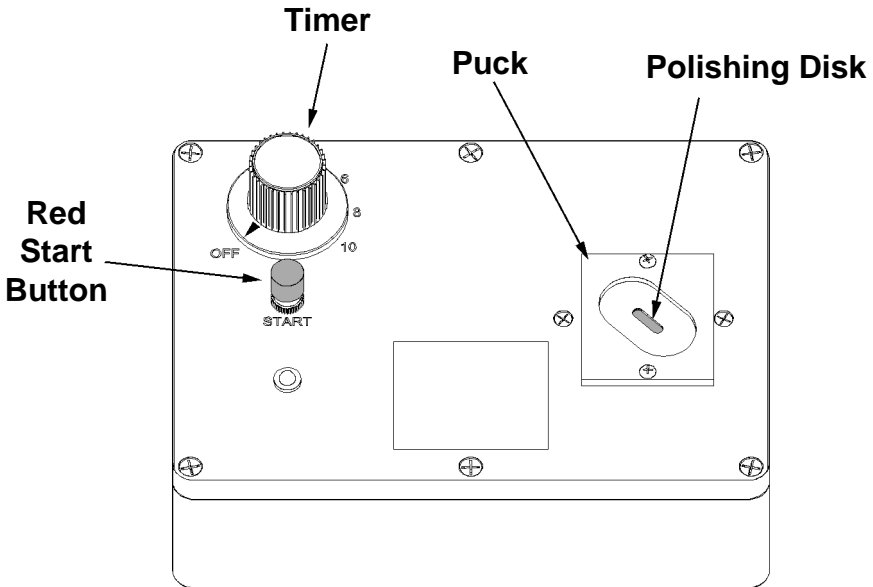

## FOCP-1 INSTRUCTION MANUAL

Document Number RE:00A2-FOCP1

Nanometer Technologies (NMT) has prepared this manual for use by NMT personnel, licensees, and customers. The information contained herein is the property of NMT and shall not be reproduced in whole or in part without the prior written approval of NMT.

NMT reserves the right to make changes without notice to the specification(s) and materials contained herein and shall not be responsible for any damages (including consequential) caused by reliance on the materials presented, including but not limited to typographical or listing errors.

Please address any questions, comments and suggestions to:

### NANOMETER TECHNOLOGIES

2501 Golden Hill Rd.  
Paso Robles, CA 93446  
Telephone: 805-226-7332  
Fax 805- 226-8753  
[www.nanometer.com](http://www.nanometer.com)

Have technical questions?  
*Contact:* Gary Karger - [gk@nanometer.com](mailto:gk@nanometer.com)

July 9th, 2004

## Step 1

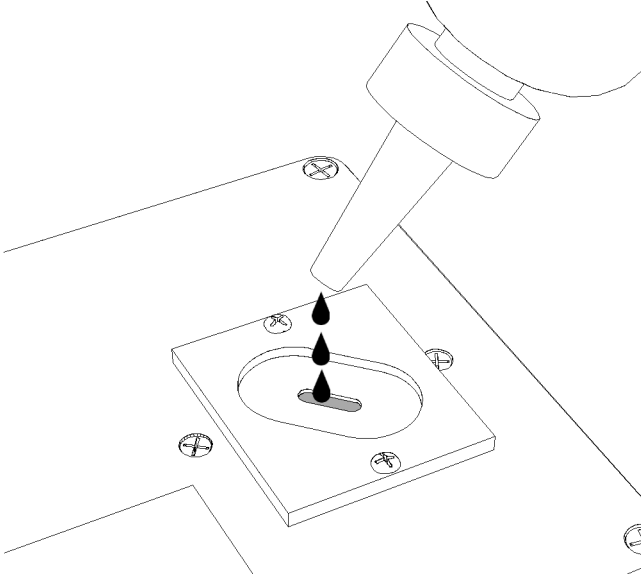

Apply approximately 5 drops of polishing solution (UPS-1) into the slot.  
(5 drops of solution will do 2 - 3 connectors)

## Step 2

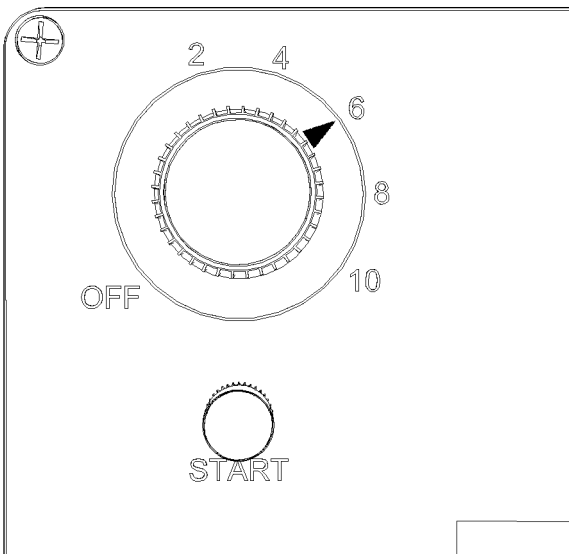

Set Timer to desired amount of seconds.

If no specific time is selected, the Red Start Button can be held down and used for intermittent use.

## Step 3

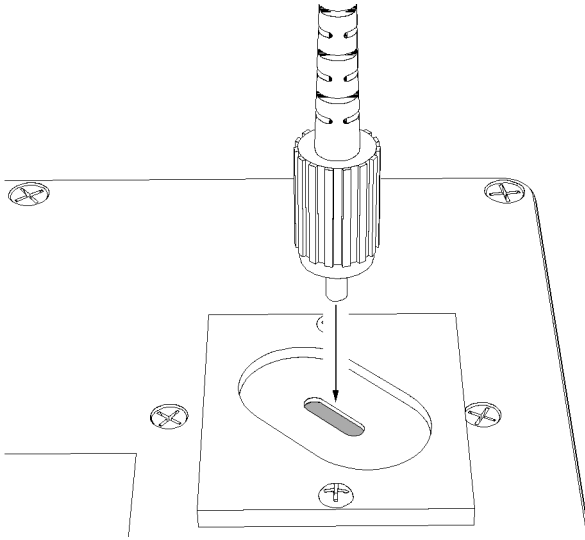

**Insert the connector ferrule into the Puck.  
DO NOT APPLY PRESSURE YET!**

## Step 4

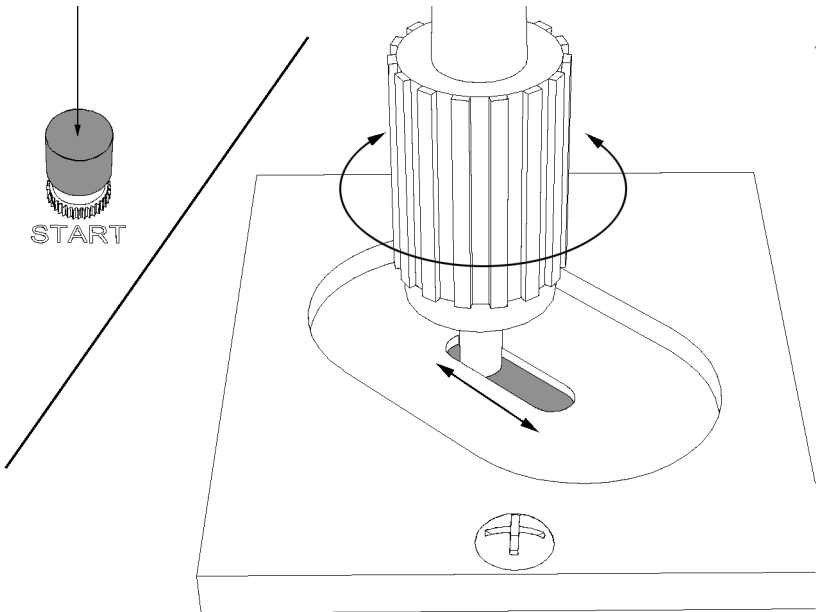

**Press the Red Start Button and apply downward pressure to the connector. Move and rotate the connector in the Puck until the FOC-1 stops or when the desired polishing time is reached.**

## Step 5

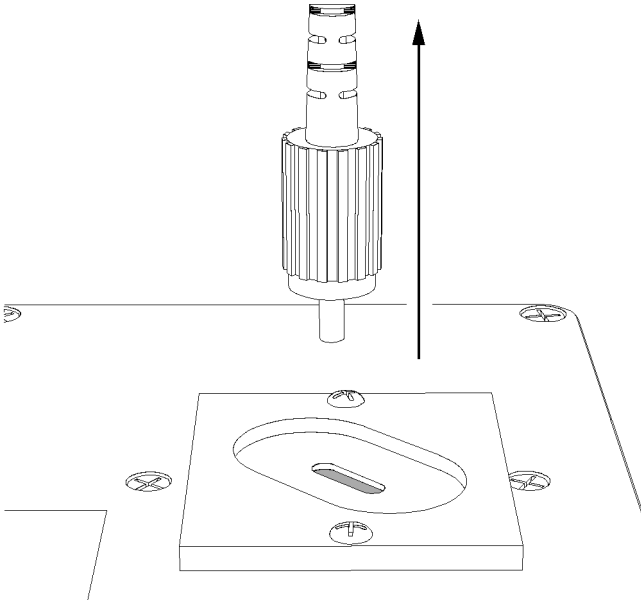

**Remove the Connector from the Puck.**

---

## Step 6

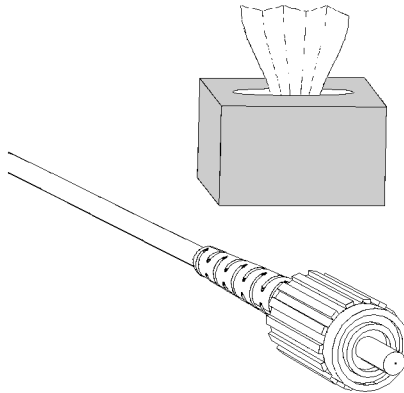

**Clean the connector ferrule using distilled water and clean lint-free wipe.  
DO NOT USE ALCOHOL!**

# Step 7

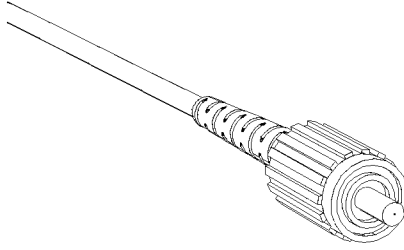

1. Inspect the ferrule end face with a scope. If the face of the ferrule is not clean, re-clean it.
2. Make a return loss measurement. (follow MFG's instructions)
3. If the return loss is not more than -50dB, repeat polishing process.

**DO NOT POLISH CONNECTOR MORE THAN  
10 SECONDS TOTAL**

---

## MAINTENANCE

1. **Replacement of polishing pads** - Pads should be replaced every 75 - 100 connectors, or when you are not getting desired results.
2. **Charge battery with A/C adapter** - Use adapter when near 110V power supply. Do not over charge!
3. **Replace battery every 40 hours of use.** ( 9 volt NI-CAD )

# Limited Warranty

Nanometer Technologies products shall be free of defects in material and workmanship for a period of 1 year from the date of purchase.

In the event of a defect in materials or workmanship, we will either replace or repair without charge (not including shipping costs) at our option any part which in our judgement shows evidence of such defect within 1 year from the date of purchase.

***This warranty does not apply to misuse, abuse, tampered, or altered items.*** At the end of the warranty period Nanometer Technologies shall be under no further obligation expressed or implied. This warranty is in lieu of any other warranty, under no circumstances will Nanometer Technologies be liable for any loss, damage, expense or consequential damages of any kind arising in connection with the use or inability to use Nanometer Technologies products.

**Nanometer Technologies Inc  
2501 Golden Hill Road  
Paso Robles, CA 93446**

***Tel: (805) 226-7332***

***Fax: (805) 226-8753***

**[www.nanometer.com](http://www.nanometer.com)**

**Nanometer Technologies Inc  
2501 Golden Hill Rd  
Paso Robles, CA 93446**

***Tel: (805) 226-7332***

***Fax: (805) 226-8753***

**[www.nanometer.com](http://www.nanometer.com)**