

Kalzip® FC façade system

Installation guidelines

Date 08/2014

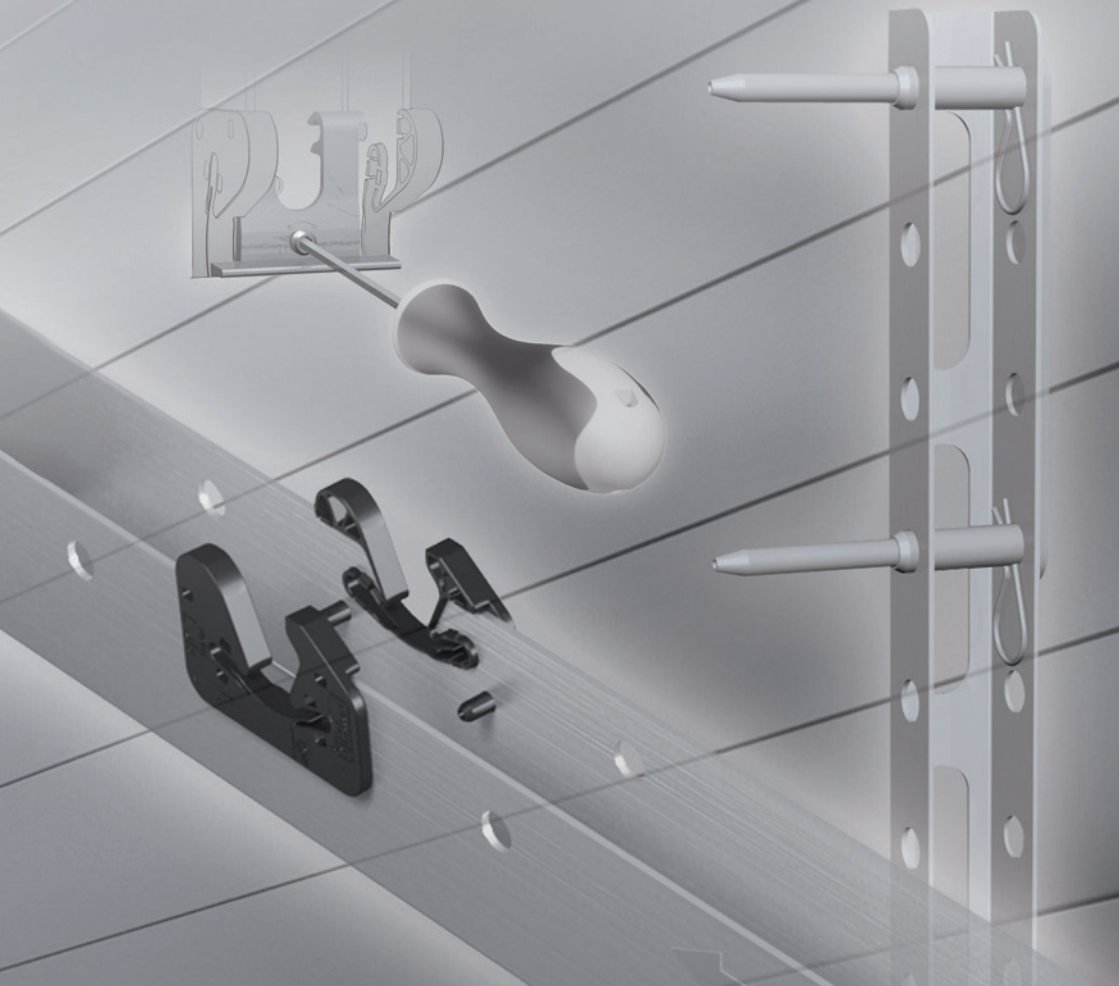

Overview	Page
1.0 Introduction	4
2.0 System overview	6
3.0 Transport, storage and handling	12
4.0 General information	14
4.1 Sub-construction alignment	15
4.2 Panel support requirements for horizontal applications	20
5.0 Sub-construction installation	24
5.1 Mono-click brackets on vertical rails	26
5.2 Modular click rail NE on vertical rails	28
5.3 Modular click rail SEL on L-brackets	30
5.4 Modular click rail SE on U-brackets	32
5.5 Modular click rail SE on horizontal rails	34
5.6 Modular click rail SE on structural cassette	36
5.7 Modular click rail setting out tool	38
5.8 Adapter SE & SEL	43
6.0 Horizontal panel installation	43
6.1 Panel installation (bottom to top)	44
6.2 Panel installation (top to bottom)	48
6.3 Vertical panel joints	50
6.4 Fixed points	52
6.5 Adjustment of panel position	54
6.6 Corner panels	57
7.0 Flashing installation	61
8.0 Panel replacement and tools	63

1.0 Introduction

This installation manual specifies the correct methods for installing the Kalzip FC façade system, including support elements, panels and accessories. It should be read together with the technical approval document Zulassung Z-14.1-581 (June 2010). It should also be used in conjunction with all other applicable technical approvals, standards and safe working procedures on the construction site.

Installation of the Kalzip FC façade is carried out using proprietary system support rails fixed to an adjustable sub-construction suitable for rainscreens. The chosen sub-construction must be capable of accommodating building tolerances to achieve a plane surface in accordance with the specifications given in this manual.

The manual contains general information about the FC façade system and its components together with detailed drawings and explanatory text for installation. The drawings are not to scale and therefore should not be dimensioned. Where appropriate, drawings are labelled with metric dimensions.

Care has been taken to ensure that the information contained within this manual is correct. At the time of going to press, the diagrams and descriptions represent our current knowledge of best practice. They are intended as rules for standard applications and do not necessarily apply in all situations. Other relevant valid standards and local legislative requirements must also be taken into account.

Suggestions for or descriptions of the end use or application of products or methods of working are for information only and Kalzip accepts no liability in respect thereof. Before using information or products supplied or manufactured by Kalzip the user should satisfy himself that they are suitable for their intended purpose.

Due to the dynamic nature of product development and continuous technical improvement, Kalzip reserves the right to make amendments to the installation instructions and technical specifications given at any time without prior notice. Users should therefore check that they have the latest available edition of this manual.

August 2014

2.0 System overview

The FC façade from Kalzip is a **fast-to-install, open-jointed, lightweight, flat metal rainscreen system. It provides a cost-effective solution for horizontally spanning cladding applications in both new-build and refurbishment projects.**

Fixing-free supports

The FC façade system is supplied with proprietary fixing-free panel supports. Panels can be clicked into either individual support brackets (mono-click brackets) or continuous modular rails (modular click rails). In summary the system consists of:

- FC panels with edge returns
- A range of modular click rails with adapters for non-standard cover widths or alternatively mono-click brackets
- Additional system components, accessories and installation tools such as the fixed point clamp, guidance snapper, flashing holder and modular click rail setting out tool

To ensure trouble-free panel installation, it is essential that the modular click rails or mono-click brackets are accurately aligned according to the guidelines in this manual to give a lined and levelled underlying support for the FC panels. A range of typical adjustable sub-construction options are illustrated which provide solutions for various types of backing wall.

Profile dimensions

The FC panels are available from 250 mm to 500 mm in 50 mm cover width increments. Bespoke cover widths can be produced on request. The nominal profile depth is 30 mm. Panels can be roll-formed from min. 350 mm to max. 10 m standard lengths in the gauges given in Table 1. Longer panel lengths (up to 14 m) are possible but attention must be given to on-site handling and expansion joints.

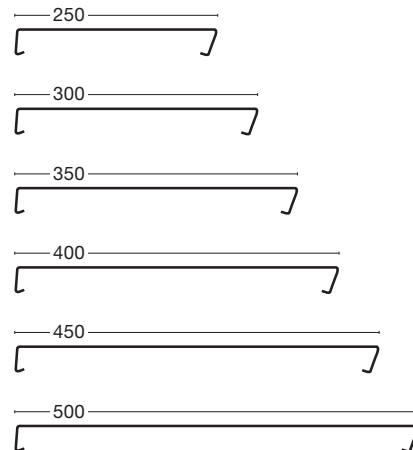
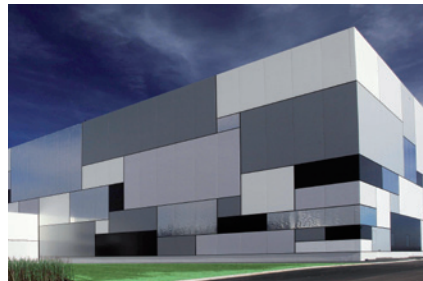

Table 1: FC panel thickness and cover width availability

Thickness (mm)	FC 30/250	FC 30/300	FC 30/350	FC 30/400	FC 30/450	FC 30/500
1.0	●	●	●	●	-	-
1.2	●	●	●	●	●	●

● Available as standard – Not available

Panel edge returns

Kalzip FC façade panels are supplied as standard with edge returns. Panels can be supplied without edge returns on request. Some of the diagrams illustrating panel installation in this manual are shown without edge returns for clarity.

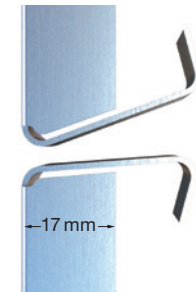

Mono-click bracket

The mono-click bracket consists of a 2 mm thick aluminium bracket fitted with specially designed plastic inlays to accommodate the upper and lower FC panel edge geometry. The plastic inlays allow the panels to easily click into place and reduce any noise caused by rattling. The bracket is supplied with two pre-drilled Ø 5.2 mm holes at 50 mm centres. The bracket must always be fixed in both holes to prevent rotation.

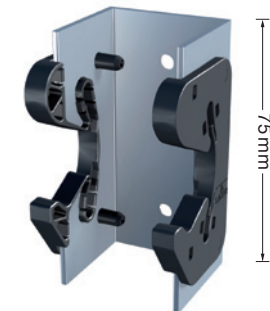

Modular click rails

There are three different types of modular click rail available for mounting FC panels (NE, SE and SEL). Fabricated from 2 mm thick aluminium and pre-fitted with plastic inlays, they are supplied in standard lengths between 2.7 m and 3.0 m. Bespoke lengths up to 6.0 m can be supplied on request. The rails are pre-punched with arrows indicating the correct way up.

Modular click rail NE

The modular click rail NE is a Non-structurally Effective support rail. That means it must be fixed at every panel support position to a structurally effective sub-construction. The rail is supplied with two Ø 5.2 mm pre-punched holes at 50 mm centres at each panel support position.

Modular click rail SE

The modular click rail SE is a Structurally Effective support rail i.e. it can be used independently as a spanning element. The spanning capacity must be calculated by the project structural engineer. It does not have pre-punched holes for fixing as the fixing position is not necessarily at the panel support positions.

Standard click rail lengths

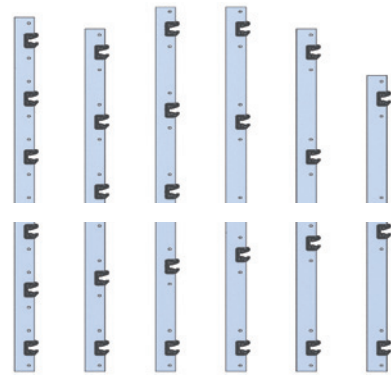

Type	250	300	350	400	450	500
Length in mm	2,950	2,900	3,000	3,000	2,900	2,700
No. of panel support points	12	10	9	8	7	6

Modular click rail NE

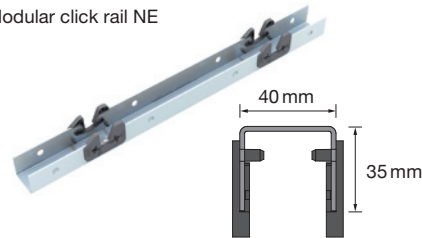

Modular click rail SE

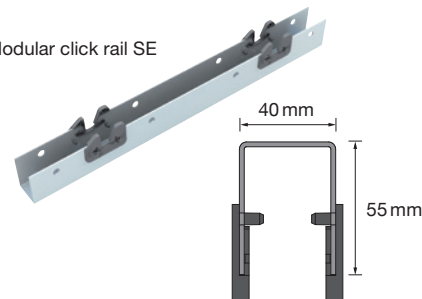

Modular click rail SEL

The SEL 40 provides a Structurally Effective rail with an integrated web for ease of fixing to standard L-profile wall brackets. The spanning capacity must be calculated by the project structural engineer.

Plastic inlays

The plastic inlays are supplied pre-fitted to mono-click brackets and modular click rails. Due to the panel profile geometry the inserts are provided for left and right sides of the rail or bracket. When correctly installed the embossed arrow indicates the upward direction. The side of the inlay is also provided with a marking for convenience of alignment using a laser level. The laser level line also corresponds to the centre of the panel gap.

Modular click rail SEL

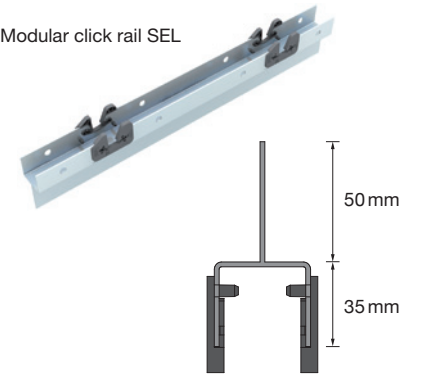

Plastic inlays

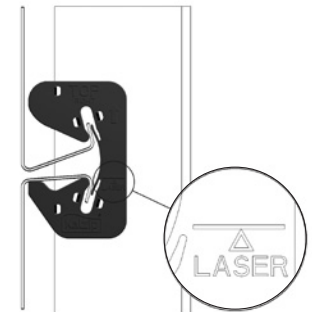

System depth



50 mm
System depth with mono-click bracket, modular click rail NE and SEL

70 mm
System depth with modular click rail SE

Setting out tool

The setting out tool is used to accurately space vertically adjacent modular click rails. Made from stainless steel, the adjustable pins can be moved up or down to accommodate the full range of standard panel cover widths. When the next rail is fixed in position, the setting tool can then be removed. See section 5.7 for detailed installation instructions.

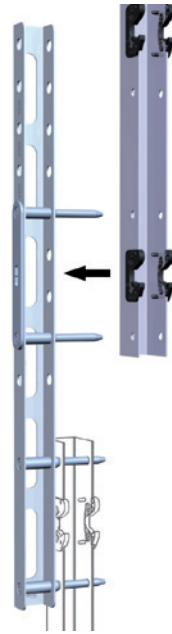
**Click rail adapter SE and SEL**

The FC click rail adapter allows non-standard panel cover widths to be accommodated at interfaces such as window heads and cills. See section 5.8 for detailed installation instructions.

**Fixed-point clamp**

Every FC panel must have a fixed point clamp installed at a single position along its length. See section 6.4 and 6.5 for detailed installation instructions.

**Guidance snapper**

The guidance snapper is designed to ensure a constant horizontal joint line between vertically adjacent panels. See section 4.2 for information on use of the guidance snapper with straight panels. The guidance snapper is also used on internal and external corner panels to ensure correct alignment. See section 6.6 for detailed installation instructions on corner panels.

**Flashing support**

The flashing support clips into the modular click rails without the need for additional mechanical fasteners. It ensures a consistent, level surface is provided to which flashings can either be screwed or riveted. See section 7 for detailed installation instructions.

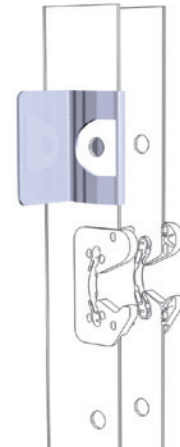
**Panel removal tools**

The two panel removal tools allow easy removal of individual FC panels without the need to demount a complete bay. The panel can either be replaced with a new one or the original panel refitted. This is a key benefit when access is required to the rainscreen cavity for maintenance, cleaning or fixing scaffolding to the backing wall. See section 8 for further instructions on individual panel removal.



3.0 Transport, storage and handling

Transportation of panels to site

As standard, FC panels are transported by road up to a maximum length of 10m. The panels are packed in pairs up to a maximum of 25 pairs per row. The table below gives maximum pack sizes for different FC panel cover widths.

Cover width (mm)	No. rows	Max. no sheets
250	4	200
300 – 350	3	150
400 – 500	2	100

System components and accessories are packed as follows:

Modular click rails

Modular click rails are supplied in standard lengths of approximately 3 m on wooden pallets. The maximum pallet size is 1.2m width x 1.2m height.

Adapter SE and SEL

Both modular click rail adapters are delivered as standard in boxes of 50.

Fixed point clamp

The fixed point clamp is supplied as standard in boxes of 100 with a 3mm Allen tool included for locking and un-locking the clamp.

Guidance snapper

The guidance snapper is supplied as standard in boxes of 100.

Unloading of panels on site

The maximum pack weight for 10m length sheets is 2.0t. Make prior arrangements for lifting gear such as cranes, fork lift trucks, spreader beams, sling belts, etc. Protect the edges of pallets if sling belts are used.

Access to the unloading point must be guaranteed, this applies for all deliveries. Before delivery, the person who has placed the order must check the site and it may also be necessary for the transport agent to check the route. Delivery dates must be agreed with the supplier.

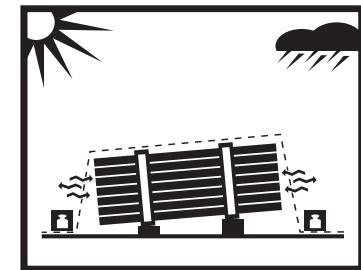
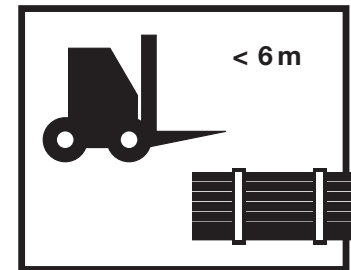

Panel storage

Panels should be stored under cover to prevent accumulation of dirt and condensation. Otherwise store at an angle on cross bearers and cover to allow air circulation.

Unpacking panels



Exercise care when opening packages stored at an angle. There is a risk of panels sliding sideways and/or in the direction of slope. When removing packaging from the panels with a knife, take care not to scratch the painted surface of the panels.

To reduce the risk of damaging FC panels, ropes should not be used. Slings with a minimum 150mm width are recommended.

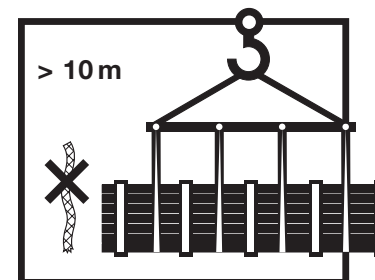
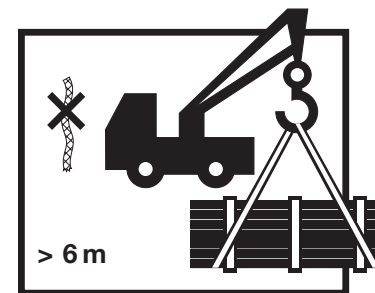

Panel protective film

FC panels are supplied with a protective polyethylene film. The film can be temporarily kept on the panels to protect them from contamination from other works. In any case the film should be removed from panels in opened packages within fourteen days.

Checking incoming materials

Obtain confirmation of any material and packaging deficiencies from the forwarder and notify the supplier immediately.

Check that the number of packages and their contents agree with the delivery documents. Inform the supplier immediately of any discrepancies in dimensions or quantities etc. Any damage occurring

during transport must be reported before installation. Claims for damaged goods will not be accepted after installation. All claims must be made within one week of arrival on the building site.

Panel handling

Suitable protective gloves should always be worn when handling FC panels. When carrying individual panels on-site, make sure to keep them in an upright position.

4.0 General information

Before commencing with installation of the FC façade system, this chapter should be read in its entirety. It contains two sections giving key information

on sub-construction tolerances and panel support requirements which applies to all sub-construction variations and panel cover widths.

4.1 Sub-construction alignment

Installation of the Kalzip FC façade is achieved in combination with a suitable sub-construction system (see section 5). The sub-construction system must be capable of accommodating building tolerances to ensure that the supporting elements are lined and levelled to within the tolerances given in this section. These requirements are divided into a number of specific criteria, all of which must be met.

Face alignment

Three conditions for the face alignment of modular click rails or mono-click brackets must be satisfied.

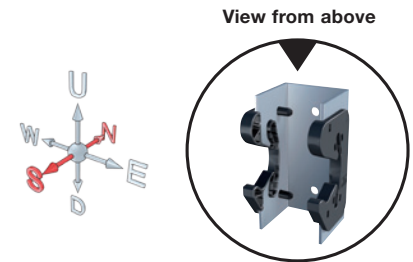

1. Over a complete length of an FC panel, no mono-click bracket or modular click rail must be positioned more than 1.5 mm from the reference line.

2. Horizontally adjacent mono-click brackets or modular click rails must be aligned within 1.0 mm of each other (independent of the distance between them).

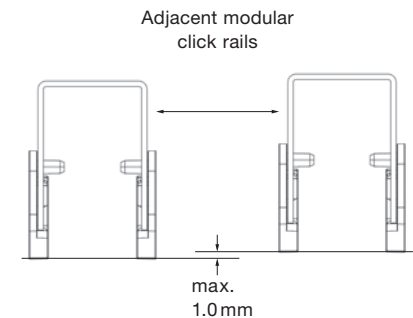
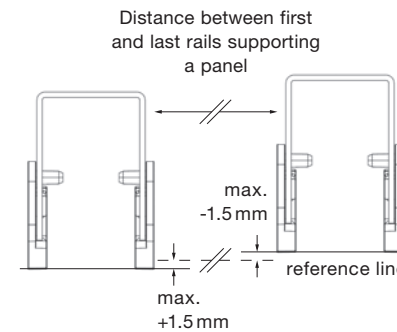

3. Vertically adjacent mono-click brackets or modular click rails must be aligned within 1.0 mm of each other.

View from side

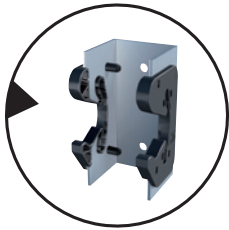

Panel cover width

The distance between panel locking points in vertically adjacent mono-click brackets or modular click rails must be within +/- 0.5 mm of the nominal panel cover width. See section 5.7 for information on using the modular click rail setting out tool.

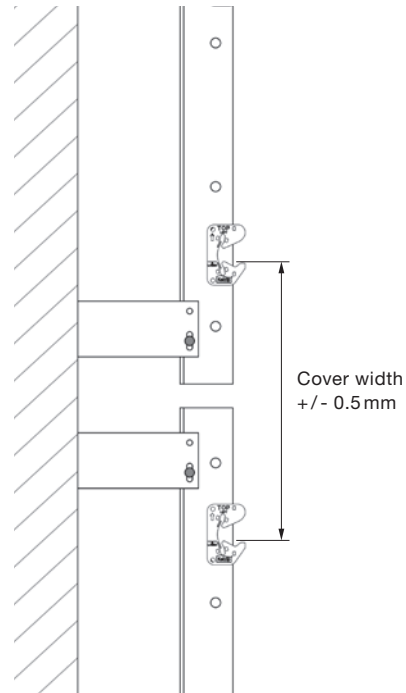
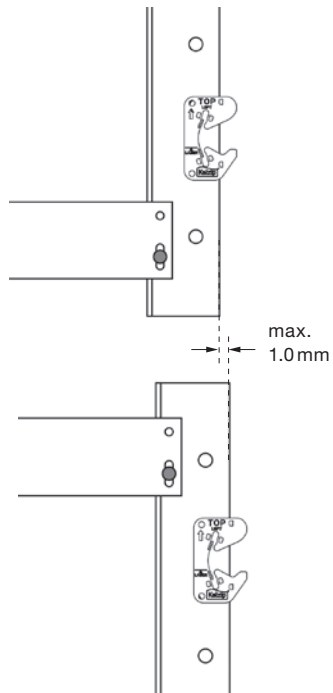

Height alignment



Note

Do not use the top of the modular click rails to take measurements – always use the laser markings on the plastic inserts to check the height alignment.

Over a complete FC panel length, the maximum deviation from the referring line must not exceed 1.5 mm.

View from front

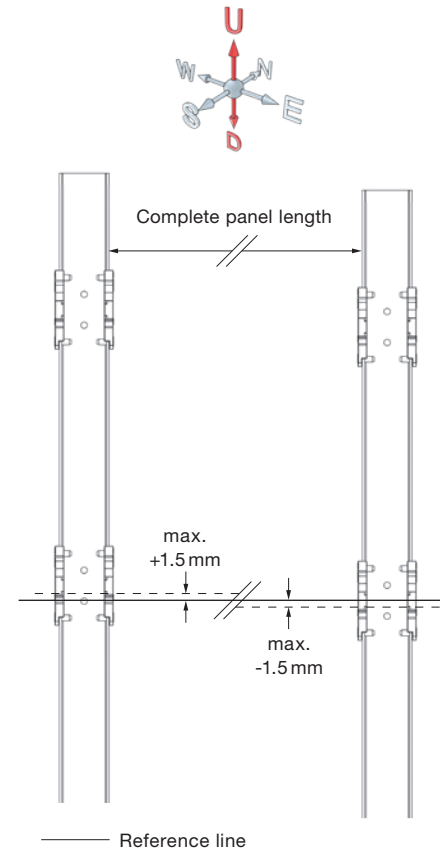
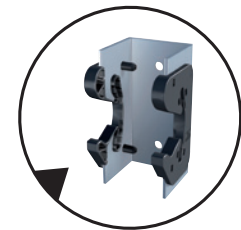

Between adjacent modular click rails or mono-click brackets, the difference in height must not exceed 1 mm (independent of rail spacing).

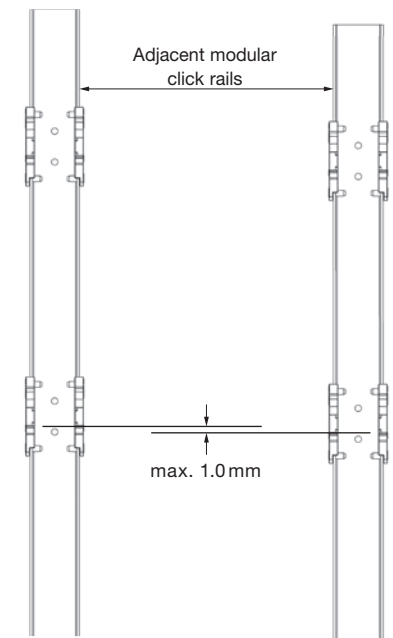

Vertical alignment

Over a 3 m distance, the alignment of modular click rails or mono-click brackets must be within + / - 5 mm of the vertical.

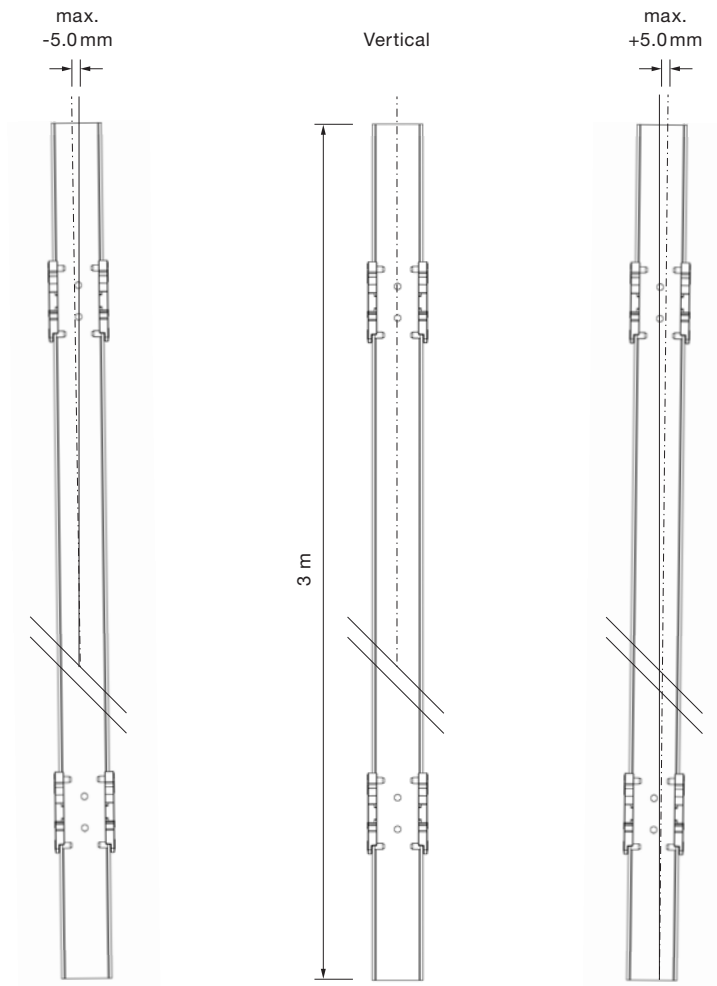
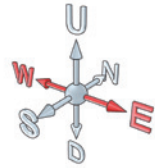

Rotational alignment

The modular click rails or mono-click brackets must be aligned to within the tolerance shown below.

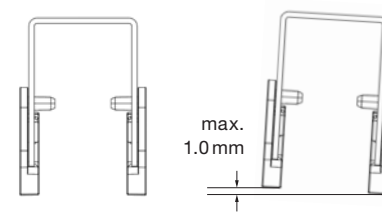

Modular click rail expansion joint

To allow for thermal movement, the modular click rails should be a maximum of 3 m lengths, preferably with the fixed point at the top of each modular click rail. It is also possible to make the fixed point in the centre of the modular click rail as shown in the example below.

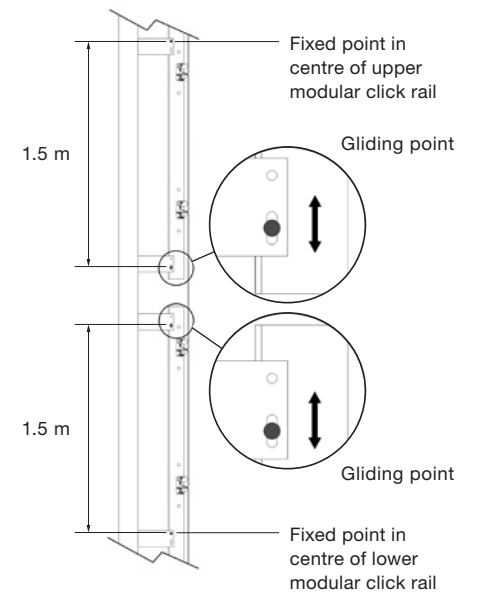
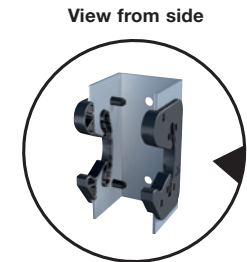

4.2 Panel support requirements

This section gives an overview of general panel support requirements for horizontal applications. Section 6.3 gives further information on vertical panel joints.

Panel overhangs

To ensure sufficient room for the installation of flashings (either directly on the sub-construction or using the proprietary flashing support) the minimum distance between the centre of the panel support point and the edge of the panel is 80 mm. The maximum allowable panel overhang is 20 % of the panel span unless detailed calculation is used to determine otherwise.

Minimum joint width

All vertical panel joints must be a minimum of 10 mm width. This is to ensure there is sufficient space for the panels to expand and contract. For panels longer than 10 m, 1 mm per linear metre gap should be allowed.

Flashing holder

To allow for installation of panels, the maximum overall depth of joint backing flashings is 13 mm.

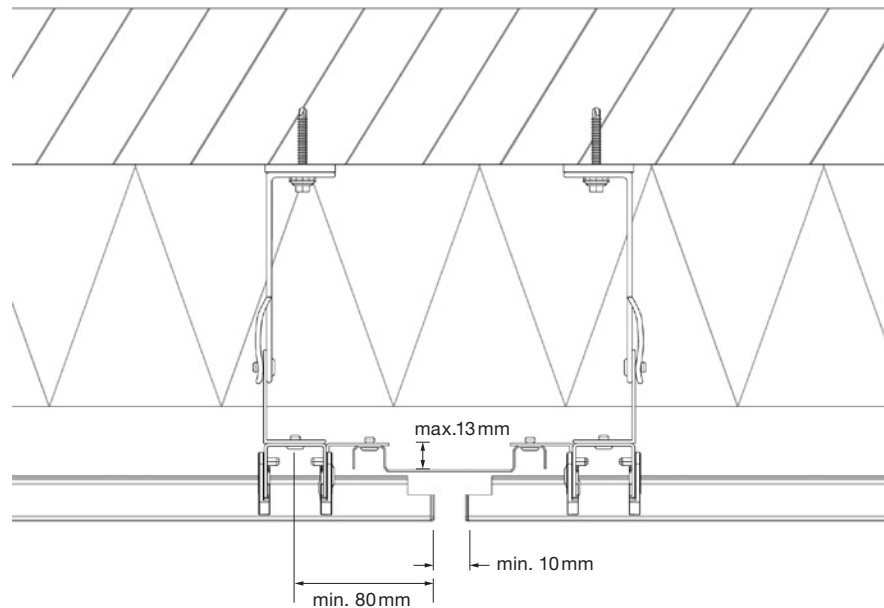

Stop

A single mono-click bracket or modular click rail must never be used to support two FC panels.

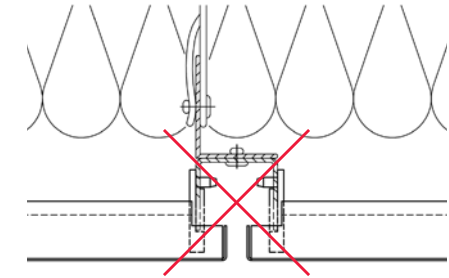

Maximum panel span

The maximum panel span (distance between adjacent panel supports) is limited to 1.60 m independent of structural performance.

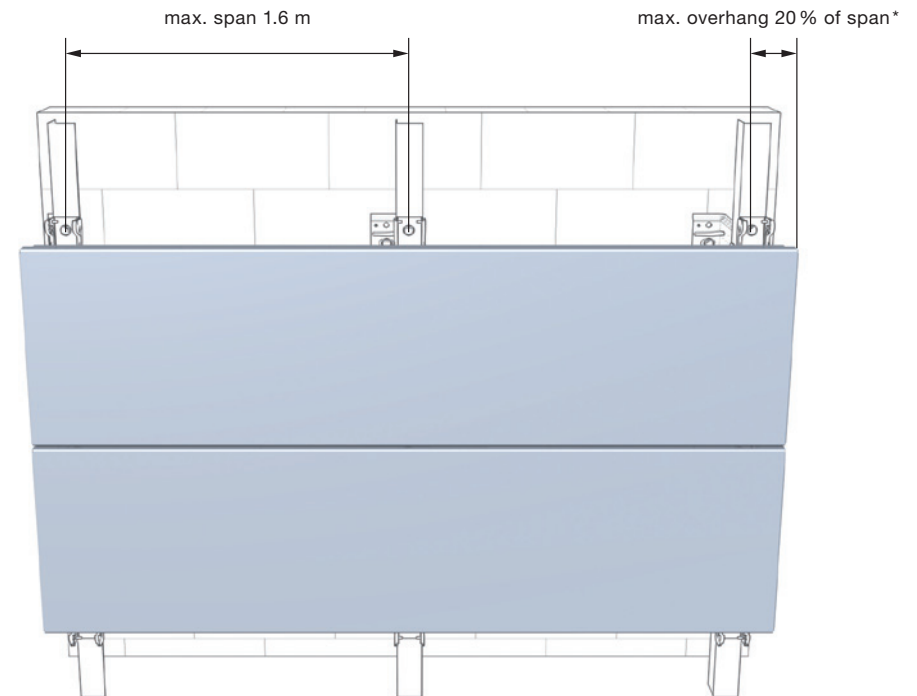

* unless detailed calculation is used to determine otherwise.

Straight panels

Every standard FC panel requires a single fixed point clamp and at least one guidance snapper. The fixed point allows for the control of thermal movement of the panel. The guidance snapper provides a positive panel engagement and thereby ensures a consistent horizontal panel-to-panel joint line.

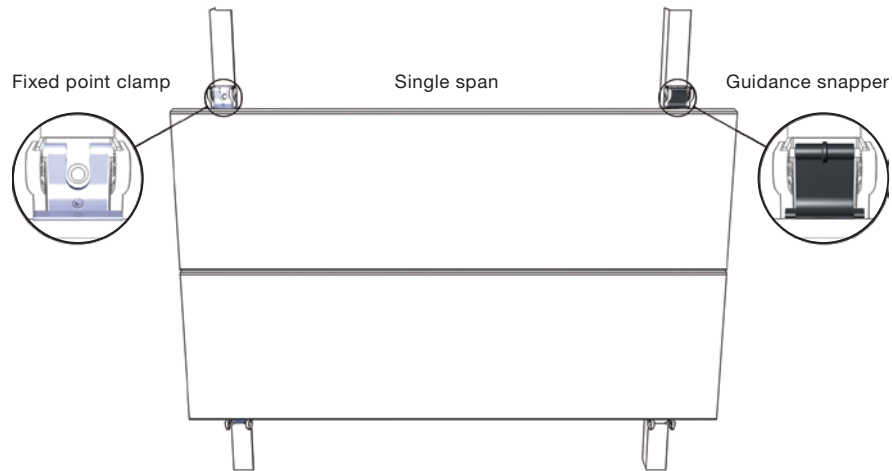

Corner panels

Corner panels should be installed with a fixed point at a minimum distance of 80 mm and a maximum 20 % of the length of that side of the corner panel. For corner panels with unequal length sides, the fixed point should be installed on the long side of the panel. Guidance snappers must be installed at both ends of all corner panels, whether they have unequal sides or not. See section 6.6 for further information on corner panel installation.

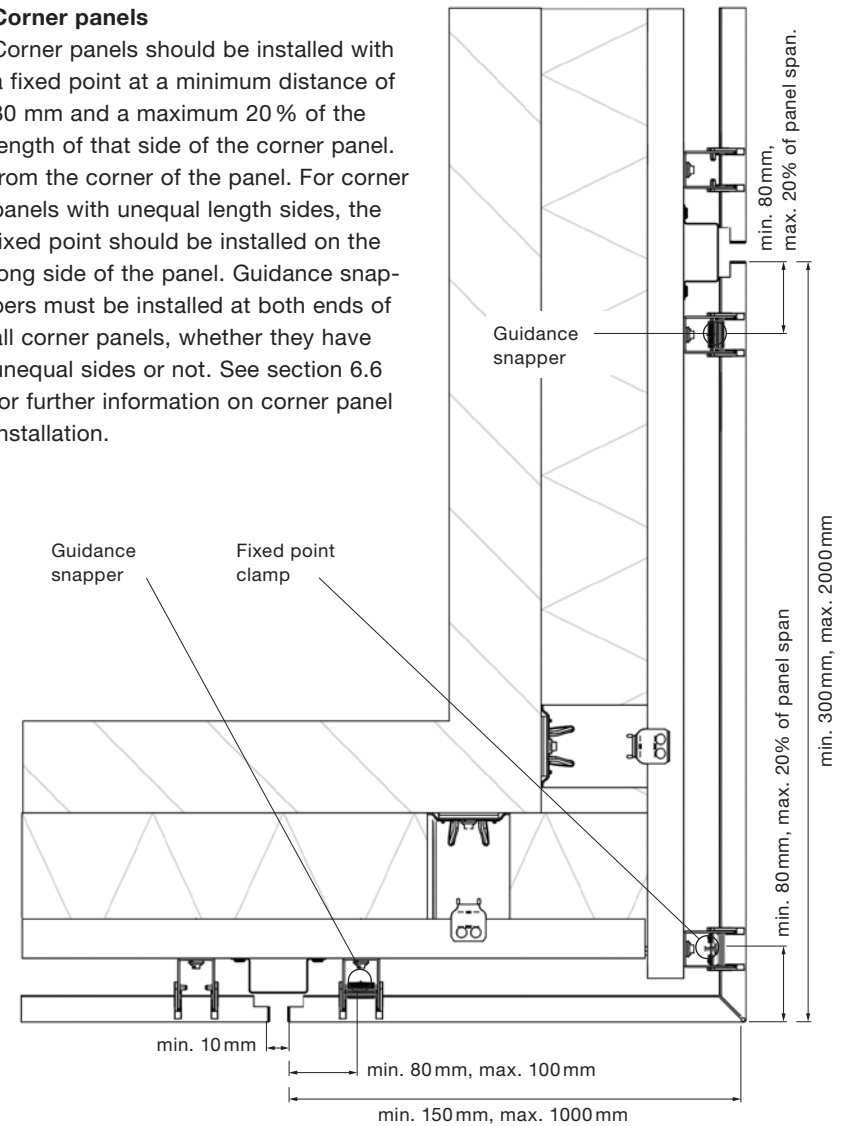

5.0 Sub-construction installation

The Kalzip FC façade system must be installed on an adjustable sub-construction system. This is required to ensure a lined and levelled surface for supporting elements. It also provides a cavity for wall insulation and

an air gap for drainage and ventilation. This chapter gives an overview of six different variations on a range of types of backing wall. The type numbering follows the same sequence as the 2D and 3D construction details.



Type 1
Mono-click brackets on vertical rails



Type 2
Modular click rail NE on vertical rails



Type 3
Modular click rail SEL on L-brackets



Type 4
Modular click rail SE on U-brackets



Type 5
Modular click rail SE on horizontal rails

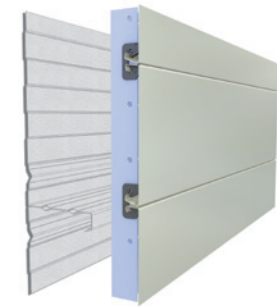

Type 6
Modular click rail SE on structural cassette

Control of thermal movement within sub-construction

For sub-constructions which use a wall bracket, each length of support rail must have a single fixed point. All other connections to the wall bracket must allow for thermal movement. To make the sliding point effective, a spacer pad must be used with the rivet gun to ensure the rail is free to expand and contract.

An alternative way of ensuring movement is to use bulbtite rivets with a grip range greater than the thickness of the two clamped materials for the sliding point and use a suitable screw fastener for the fixed point.

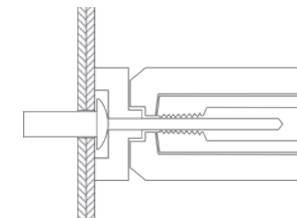
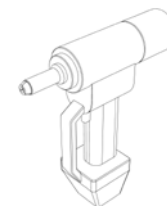
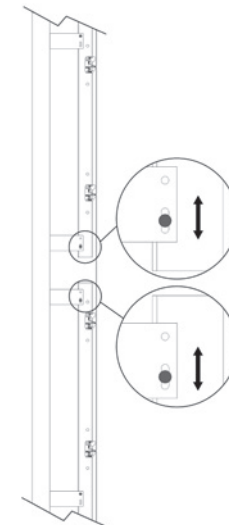

Spacer pad for rivet gun

5.1 Mono-click brackets on vertical rails

A vertical L-profile rail is fixed to the backing wall with adjustable wall brackets. The rail can be supplied with pre-drilled/punched modular holes for easy fixing of the mono-click brackets. This is particularly useful for installing panels with different standard cover widths quickly and easily.



Support rails with pre-drilled holes
Using this variation, the face and height alignment of the sub-construction is carried out in a single step. The support rails must be aligned accurately for the modular holes to line up horizontally.

Adjust the rails to the in-plane, height, vertical and rotational alignment tolerances specified in section 4.1. Check the distances A, B and C are correct according to the project drawings.

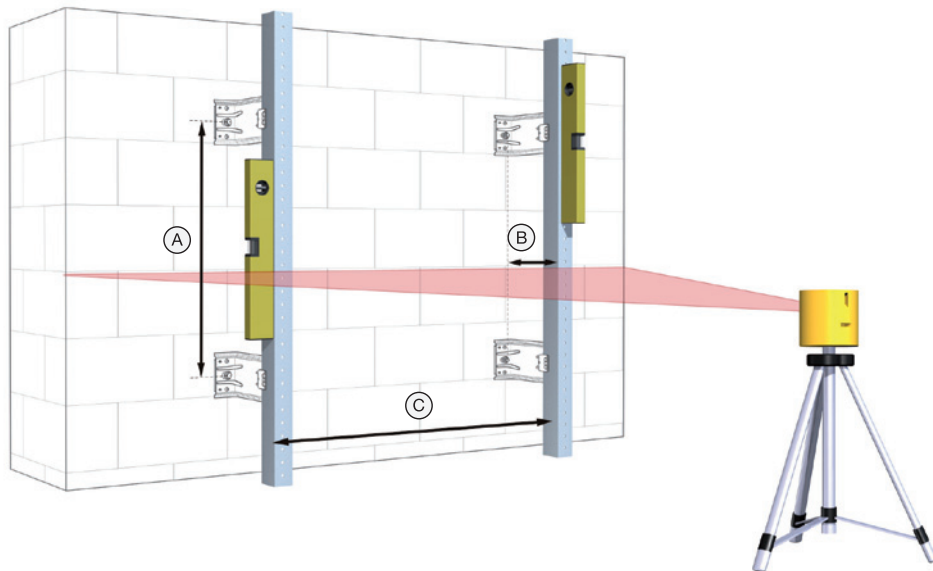

Mono-click brackets can now easily be fixed in the relevant modular holes with rivets. The $\varnothing 5.2$ mm holes are set at 50 mm centres to correspond with the holes in the mono-click bracket.

2. The position of the holes in the mono-click bracket is not related to the position of the gap between two FC panels. Therefore, the laser marking on the side of the plastic insert must be used as a datum for setting out. Always use the laser marking on the side of the plastic insert as the height reference.
3. Accommodation of thermal movement of support rails should be carried out according to one of the methods described in section 5.0

 **Notes**

1. Every mono-click bracket must always be secured with two rivets. One fixing per mono-click bracket is not sufficient to prevent it rotating.

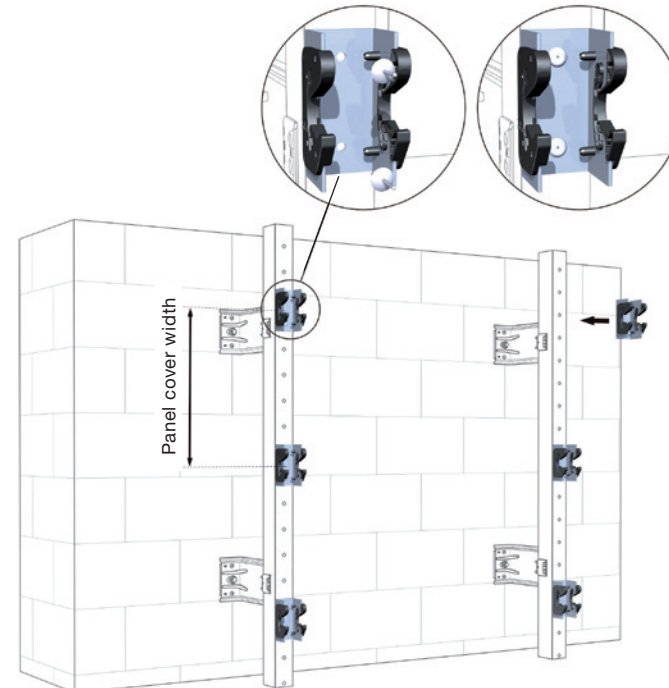

5.2 Modular click rail NE on vertical rails

The modular click rail NE is fixed to vertical support rails. Use of this system allows adjustment to be made in two subsequent steps and provides an easy-to-install solution with standard wall brackets.



Vertical support rails

The vertical L-profiles must first be accurately aligned in the plane of the backing wall. Adjust the rails to the in-plane, vertical and rotational alignment tolerances specified in section 4.1.

Check the distances A, B and C are correct according to the project drawings. The height alignment of the rails is not as critical as for rails with pre-punched holes.

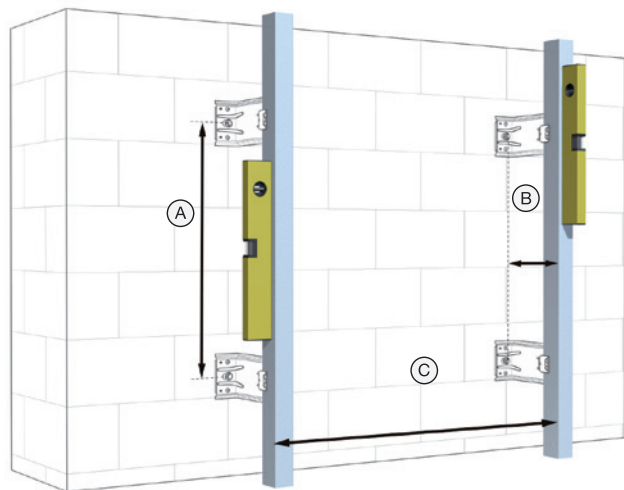

Fixing modular click rail NE

Align the modular click rails on the vertical support rails and adjust the height accurately with a laser.



1. The modular click rail NE must be fixed at every panel locking position. Two pre-punched $\text{Ø} 5.2 \text{ mm}$ holes are

provided in the modular click rail NE for rivets or screw fixings. The number of fixings must be installed according to the project structural design calculations and drawings.

2. Accommodation of thermal movement of support rails should be carried out according to one of the methods described in section 5.0.

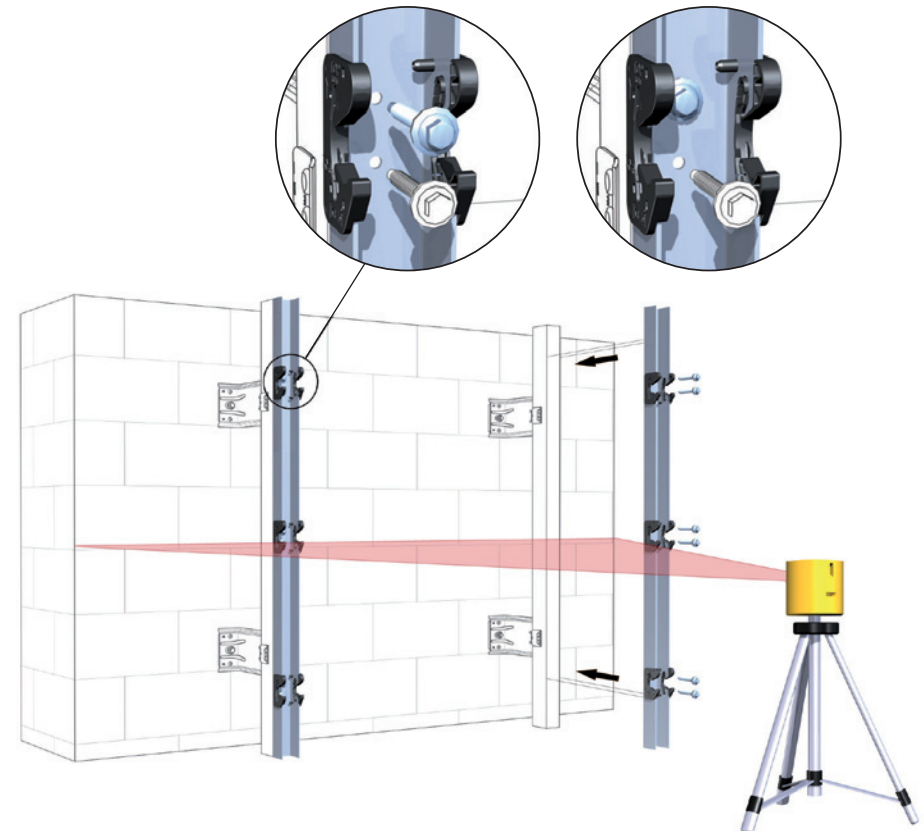

5.3 Modular click rail SEL on L-brackets

The modular click rail SEL is a structurally-effective vertical support rail compatible which can be fixed directly to standard wall brackets. Alignment of this sub-construction variation, using only two components is carried out in a single step.



Installation procedure

Install the SEL modular click rail onto standard wall brackets. Using this system, the complete alignment of the sub-construction must be carried out accurately in a single step.

Adjust the rails to the in-plane, height, vertical and rotational alignment tolerances specified in section 4.1. Check the distances A, B and C are correct according to the project drawings.

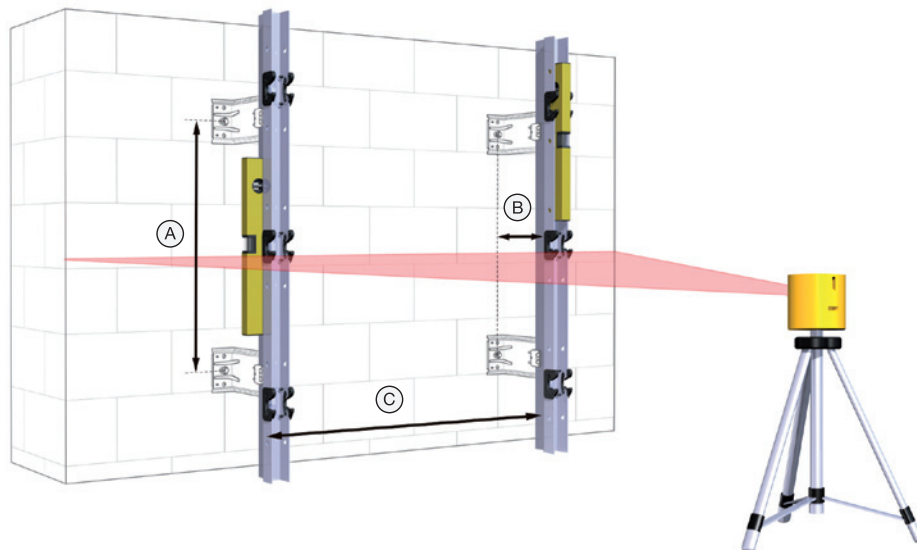

Fixed point

One or two rivets or screws (according to structural requirements) fixed in circular holes.

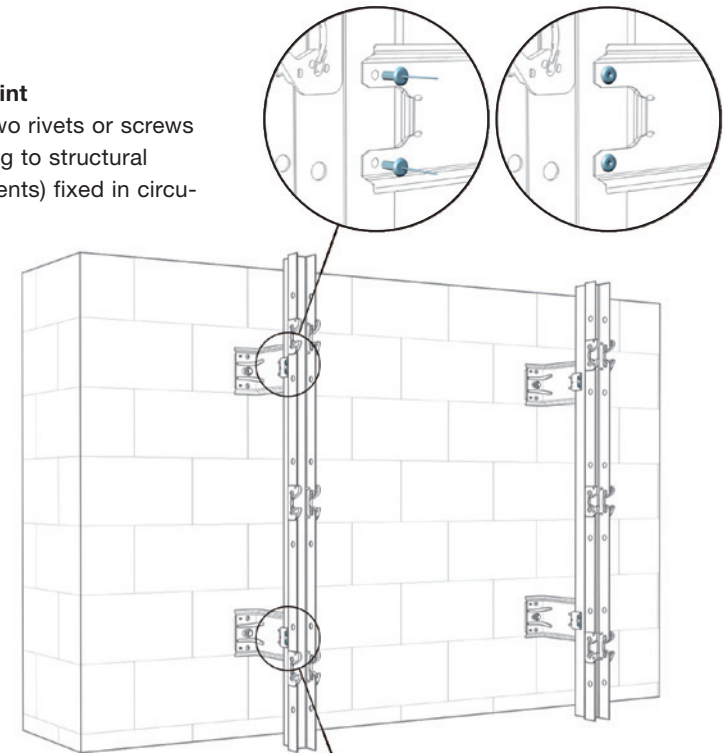

Sliding point

One or two rivets or screws (according to structural requirements) fixed in slotted holes.

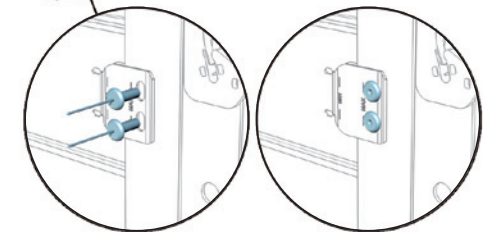

Note

Accommodation of thermal movement of support rails should be carried out according to one of the methods described in section 5.0.

5.4 Modular click rail SE on U-brackets

The structurally effective modular click rail (SE) can span between U-profile wall brackets, providing an economical solution using only two components.



Installation procedure

Install the modular click rail SE onto U-profile wall brackets. Using this system, the complete alignment of the sub-construction must be carried out accurately in a single step.

Adjust the modular click rails to the in-plane, height, vertical and rotational alignment tolerances specified in section 4.1. Check the distances A, B and C are correct according to the project drawings.

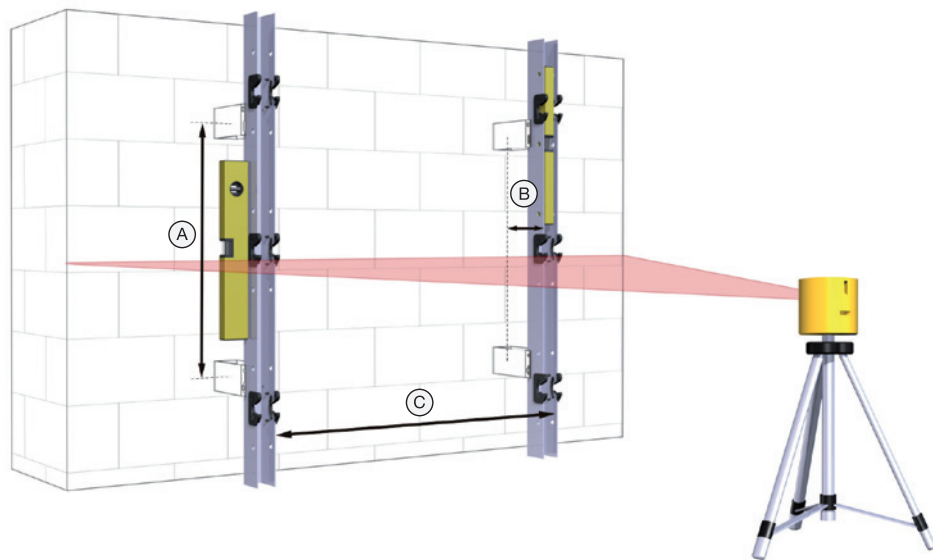

Fixed point

Rivets or screws fixed in circular holes (on both sides).

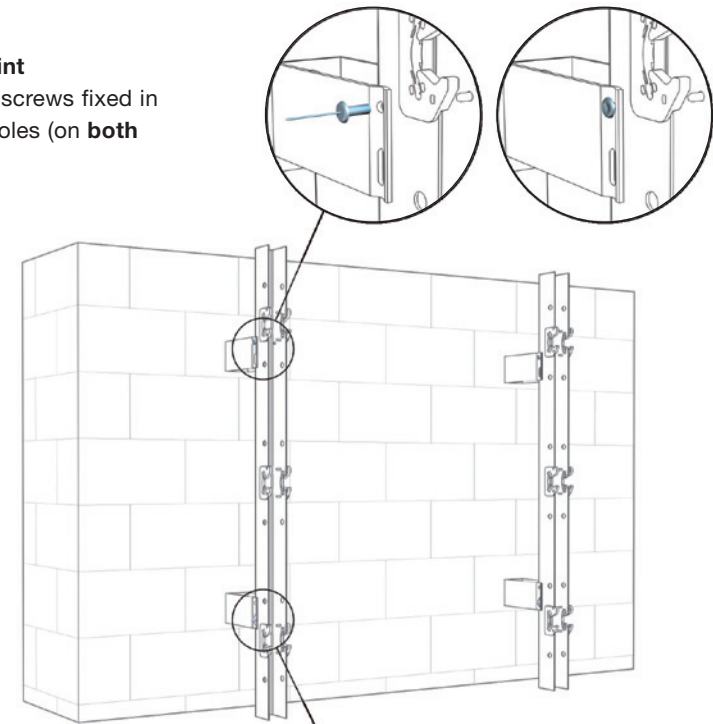

Sliding point

Rivets or screws fixed in slotted holes (on both sides).

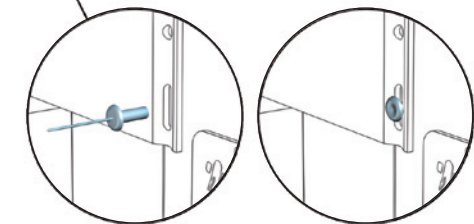

Note

Accommodation of thermal movement of support rails should be carried out according to one of the methods described in section 5.0.

5.5 Modular click rail SE on horizontal rails

Using horizontal rails fixed to adjustable wall brackets simplifies the installation procedure by splitting the alignment of the modular click rails into two steps – alignment in the plane of the backing wall followed by height and vertical alignment.



Installation procedure

Install the horizontal rails onto standard adjustable wall brackets. Adjust the in-plane alignment of the horizontal rails to the tolerances specified in section 4.1. Check the distances A, B and C

are correct according to the project drawings. Accommodation of horizontal thermal movement of support rails should be carried out according to one of the methods described in section 5.0.

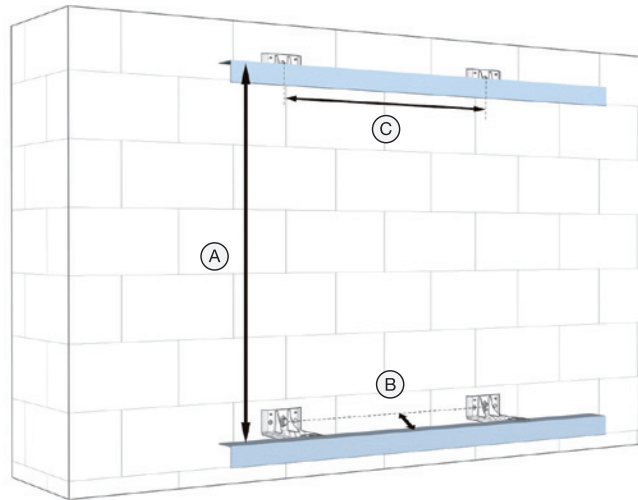

The modular click rail SE can be fixed to the horizontal rails with self drilling / tapping screws or with rivets.

Adjust the vertical alignment of the modular click rail SE to the tolerances specified in section 4.1.

Always use the laser marking on the side of the plastic insert as the height reference.



Note

The number of fixings must be installed according to the project structural design calculations and drawings.

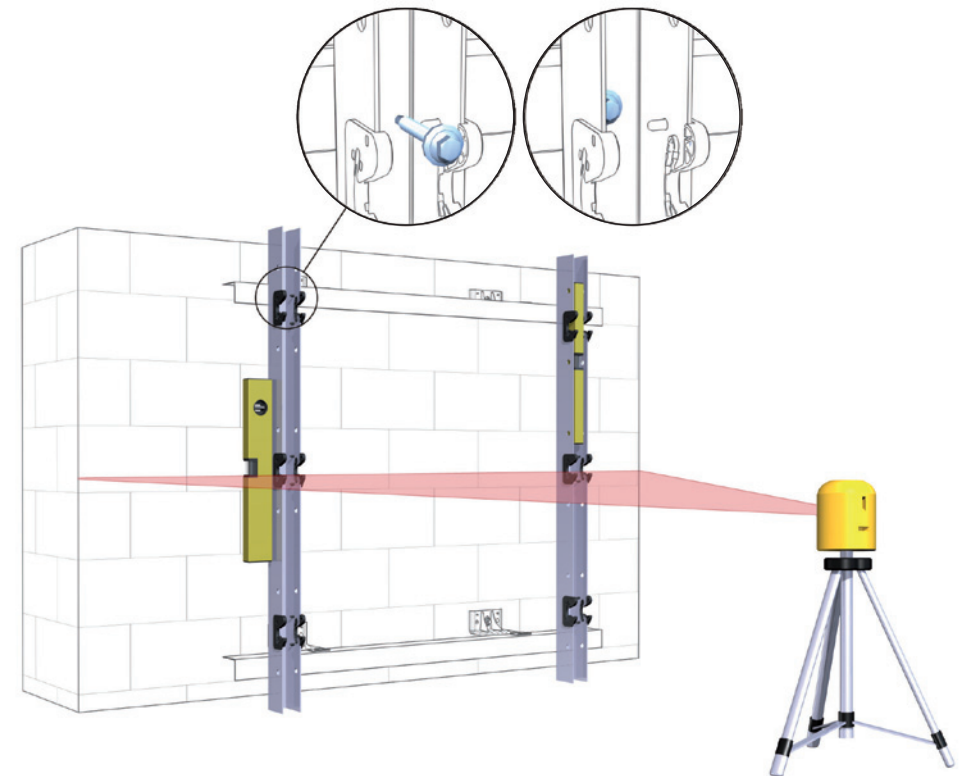

5.6 Modular click rail SE on structural cassette

For installation on steel structural liner trays, the modular click rail is fixed to the top flanges of the tray.

The structural effective rail is used to accommodate the difference between the FC panel cover width and the cassette flange spacing.

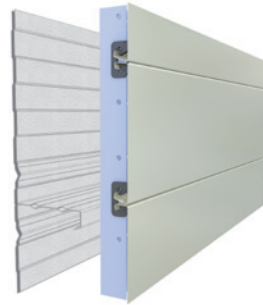

Installation procedure

Using this variation – without an adjustable sub-construction – it is essential that the structural cassettes themselves provide an in-plane and level surface on which to install the modular click rails. Any discrepancies in alignment must be accommodated by additional

shims to the thermal break as required. Using structural cassettes as the backing wall, the maximum spacing between modular click rails must be verified by the project structural engineer. The dead weight of the modular click rails and FC panels must be either transferred back to the building structure at

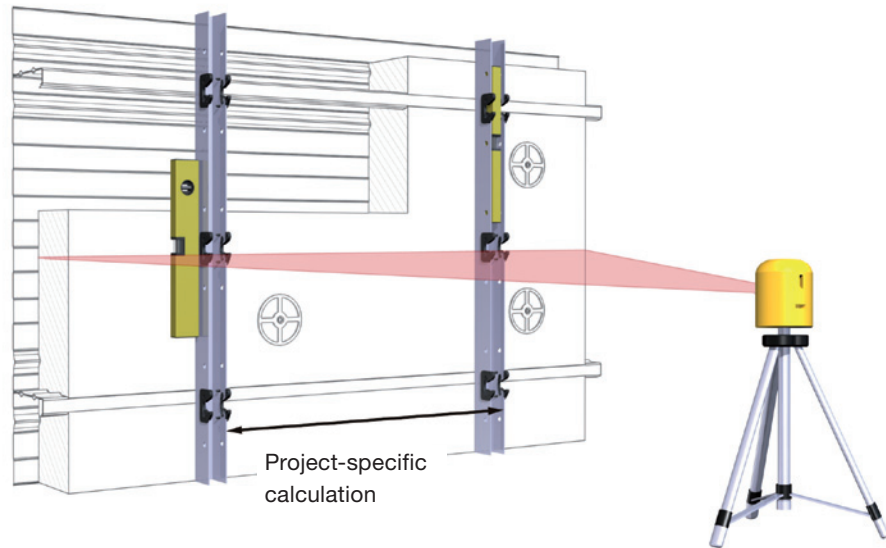

the top of each click rail or supported at the base of the click rail. Check the rails are aligned to the tolerances specified in section 4.1. The modular click rail SE can be fixed to the structural cassette with self drilling/tapping screws or with rivets. Care should be taken to ensure that there is a sufficient gap between vertically adjacent rails to allow for thermal movement.



Note

The number of fixings must be installed according to the project structural design calculations.

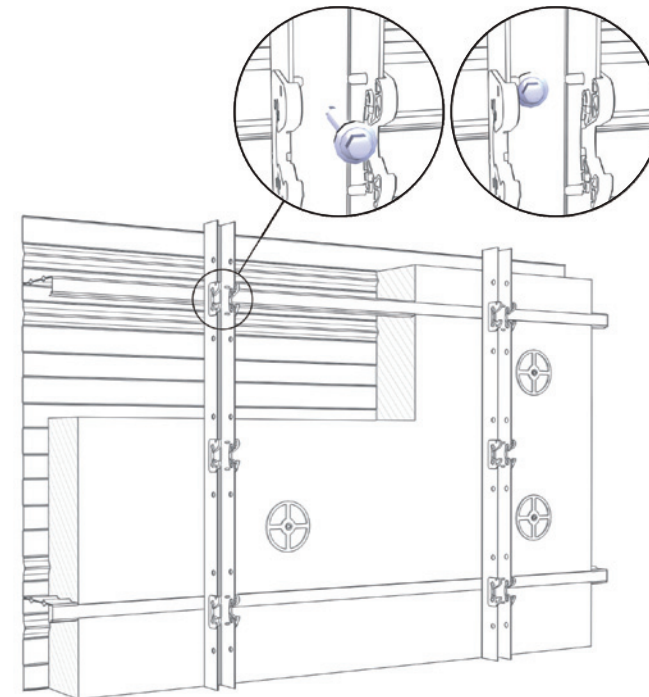

5.7 Modular click rail setting out tool

To allow for thermal expansion, all modular click rails are supplied in standard lengths of no greater than 3 metre. The setting out tool allows accurate spacing at joins between vertical rails. The tool can be adjusted to accommodate every standard panel cover width.

Panel cover width adjustment

The setting out tool consists of a rail with two pairs of pins, one pair fixed and one pair adjustable. The tool shown bottom left is set to the 500 mm cover width position. The sequence on page 39 shows how to reset the cover width to 300 mm.

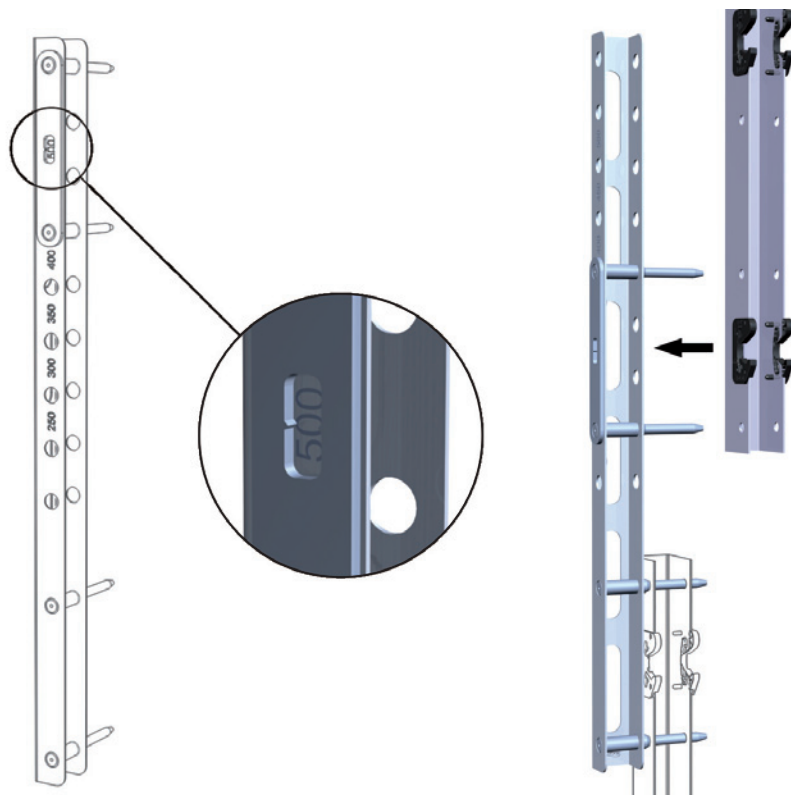

To adjust the setting out tool (1) to the required cover width, remove the two clips holding the adjustable pins in place (2), pull the pins out of the rail (3) and relocate in the appropriate holes (4).

Replace the clips to secure the pins in their new position (5). The cover width set is shown in the window in the side of the adjustable pins (6). The sequence (1) to (6) below shows each step.

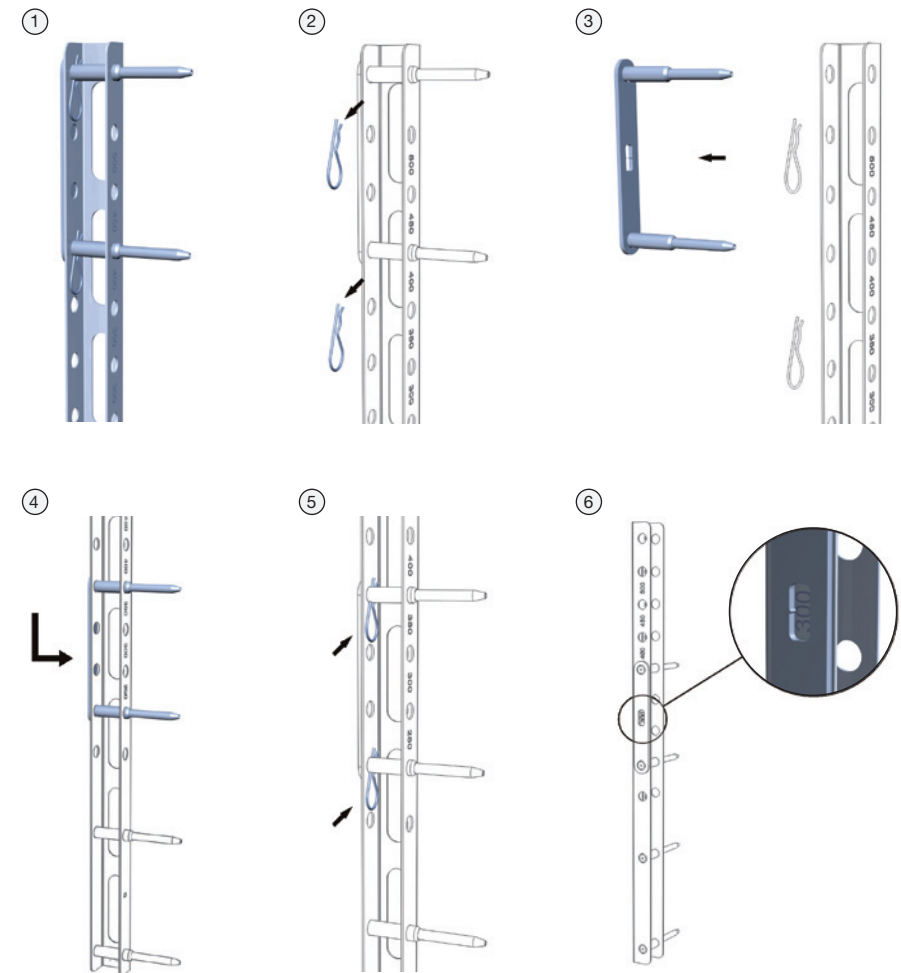

Setting out modular click rails

The modular click rails are provided with pre-punched holes in their sides to accept the setting out tool locating pins.

1. Align and fix the lower set of modular click rails according to the tolerances given in section 4 and the relevant type of sub-construction described in section 5.

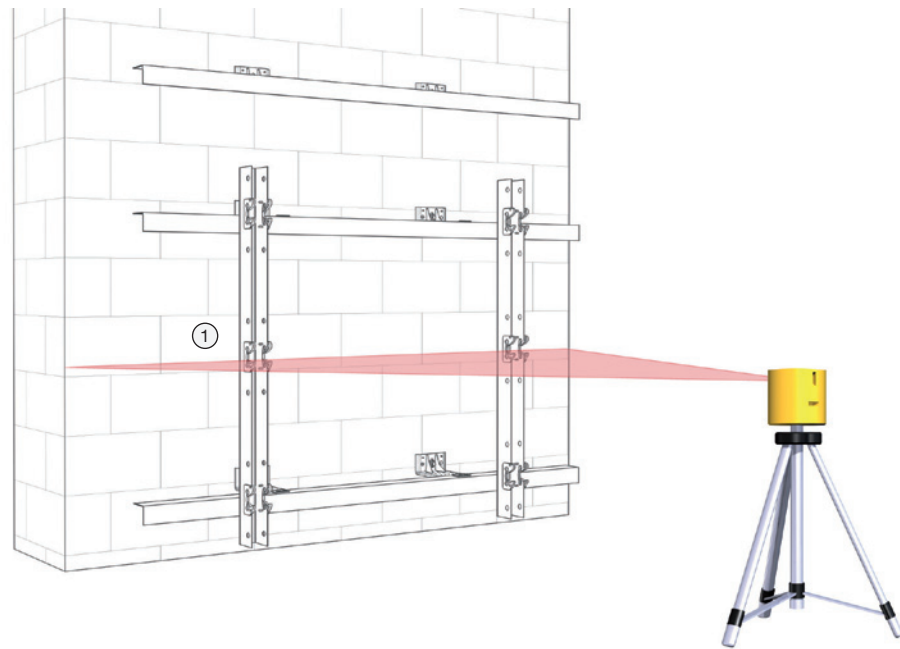

2. Insert the lower set of locating pins of the setting out tool into the top set of holes in the lower modular click rail.

3. Insert the bottom of the upper modular click rail into the top set of pins and check the alignment of the rail with a spirit level.

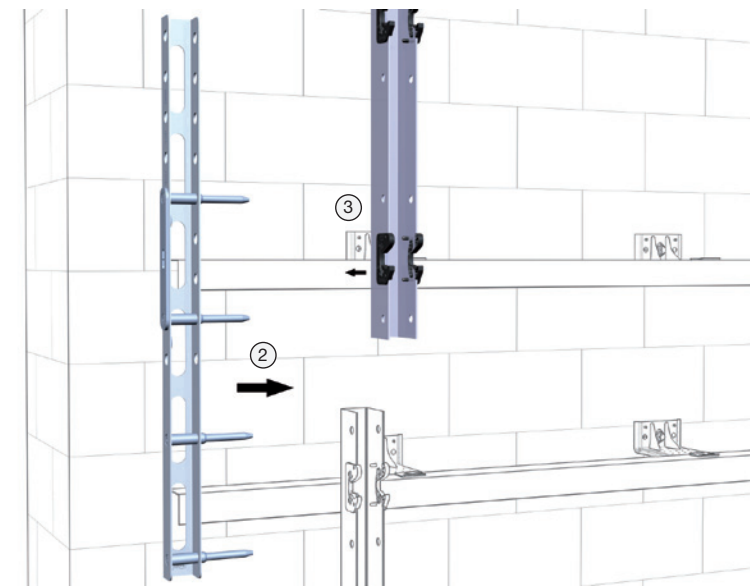

4. Double check that the correct panel cover width is showing in the window in the side of the tool and fix the top modular click rail in position.
5. Best practice is to start the next rail with the panel support position fixed directly over a wall bracket or horizontal rails. The allowable overhang of any rails must be approved by the project structural engineer.

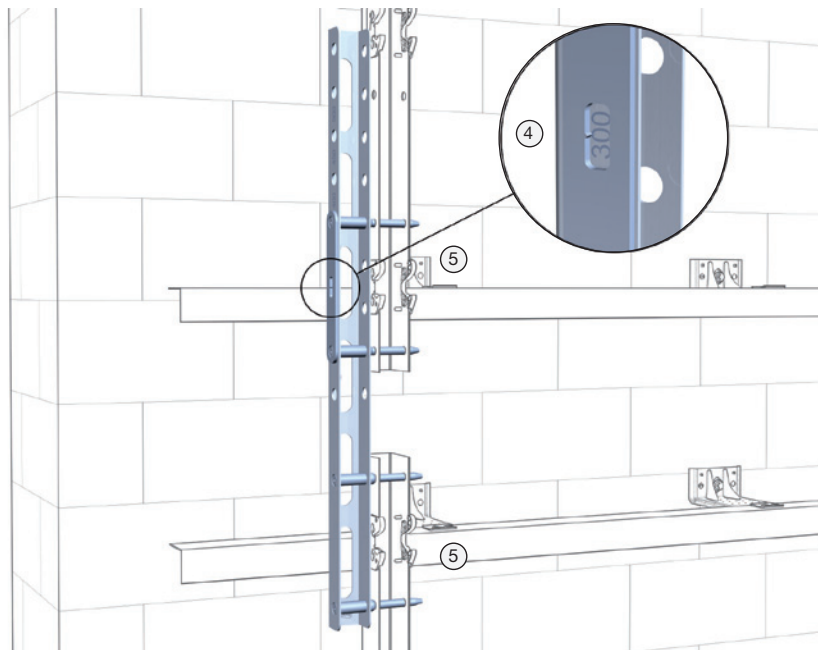

5.8 Adapter SE & SEL

The click rail adapters SE and SEL are designed to accommodate bespoke cover width panels, which may be required for example at interfaces with windows and doors. The adapter SEL is also to be used for extending the NE modular click rail.

The adapter can be installed either on the top or the bottom part of the rail. Due to this, two plastic inlays (left and right) are supplied in the box, which are to be cut and installed on-site.

Cut the modular click rail to the required length according to the cover width of the transition panel (see example below). The laser marking should be used as the reference point when measuring to the end of the rail.

P = bespoke panel cover width (mm)
 T = distance from laser marking to top of rail
 B = distance from laser marking to bottom of rail

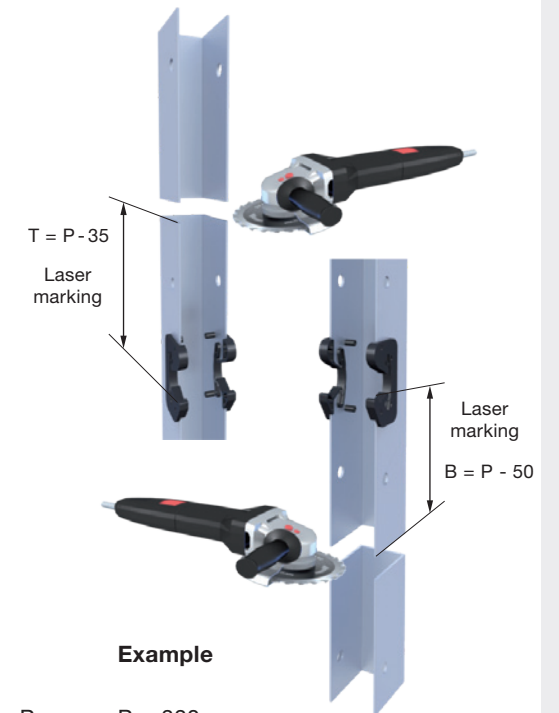
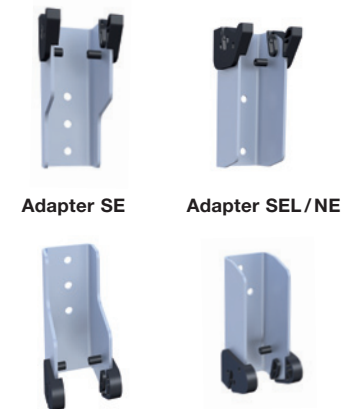

! Note

Minimum bespoke panel cover width, P_{min}
 SE = min. 100 mm
 SEL / NE = min. 130 mm

Example

P = 330 mm
 T = 330 - 35 = 295 mm
 B = 330 - 50 = 280 mm

Insert the adapter into the modular click rail and check the distance between the laser markings is equal to the transition panel cover width, P.

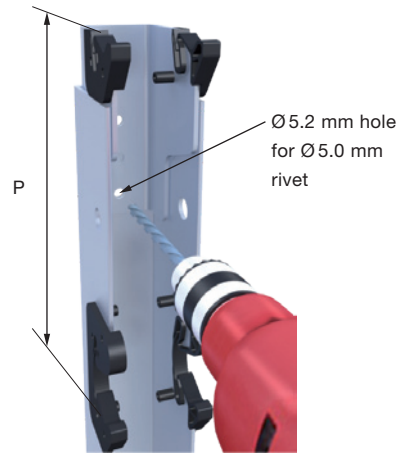

The adapter must be secured to the modular click rail with at least two fixings (it is recommended to use rivets).

All adapters are supplied with three pre-drilled holes. These are aligned centrally for the modular click rail SE and staggered diagonally for the SEL/NE rails. Use the two outer holes when possible but if the top hole is too close to the edge, use the bottom two holes.

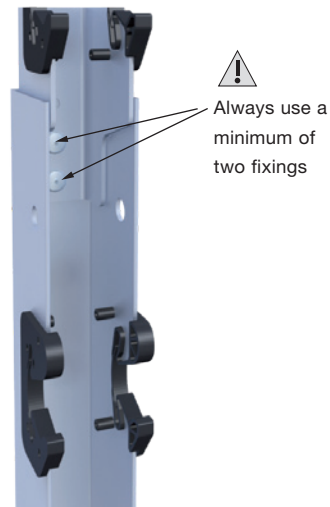

The height tolerance range is +/- 10 mm.

With the adapter in position, drill both holes through the modular click rail.

6.0 Horizontal panel installation

The following sections illustrate the installation of FC façade panels in horizontally spanning applications. The design of the FC panel profile geometry permits the installation of panels in both directions (from bottom to top or from top to bottom).

Panel edge geometry

The top and bottom edges of the panel have a different geometry, so care must be taken to ensure the panel is installed the correct way up.

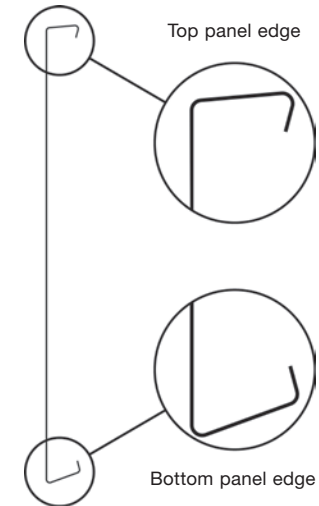

Correct panel installation

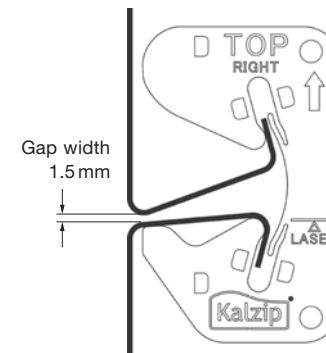

Never try to install the panels upside down.

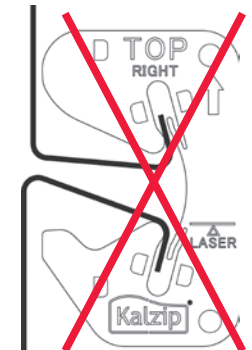

6.1 Panel installation (bottom to top)

This sequence shows the installation of FC panels from bottom to top. Refer to section 6.4 for making the fixed point.



Note

The panel overhang has been reduced in these drawings for clarity only. Refer to the panel support requirements in section 4.2.

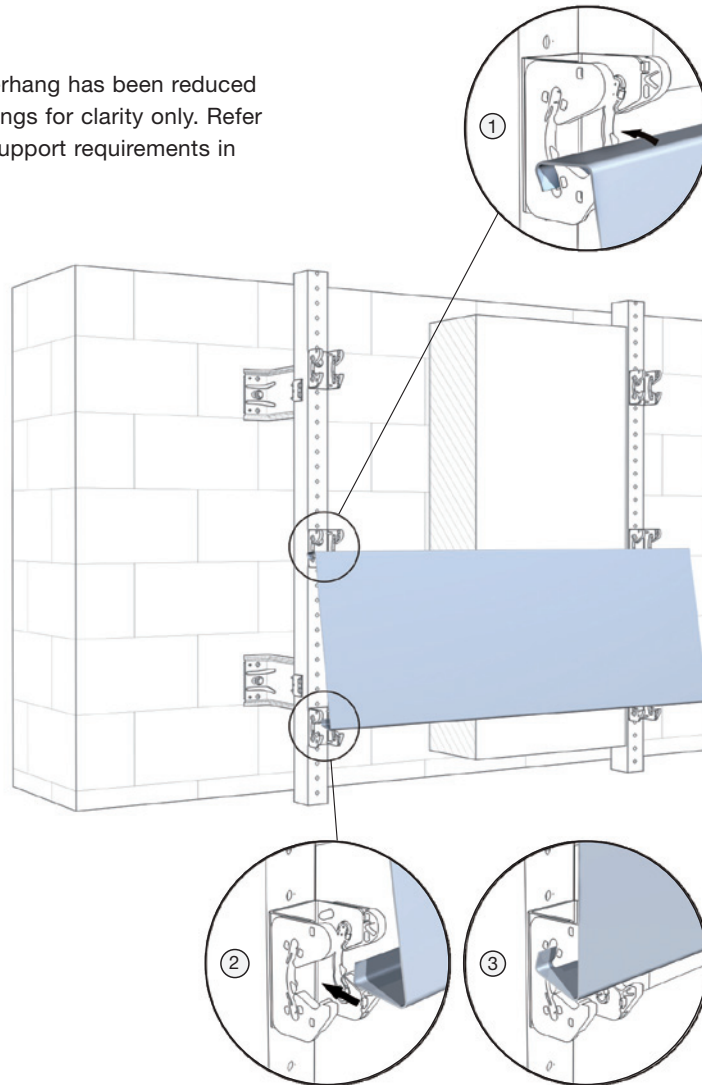

1. Insert the top edge of the first panel over **both** lower parts of the plastic inlay. Check that the panel can slide freely left to right.
2. Wearing gloves, use the palm of the hand to gently push the bottom edge of panel to click into the upper part of the inlay.
3. The bottom edge of the panel should click into place easily. Check again that the whole panel can slide freely left to right.

Never force the panel into position – this will damage the edges and may require panel replacement. If the panel does not click in easily, double-check the alignment of the sub-construction.



Stop

A single mono-click bracket or modular click rail must **never** be used to support two FC panels.

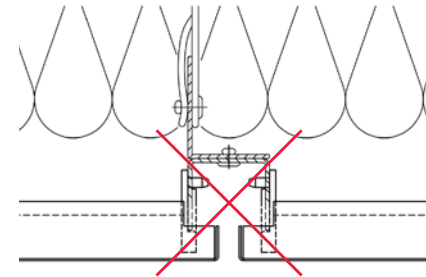

Caution

Always gently push the panel directly over the clicking point – not between the supports.

4. Install a fixed point clamp and guidance snapper(s) in the lower panel (see section 6.4) before hooking the second panel in place above.

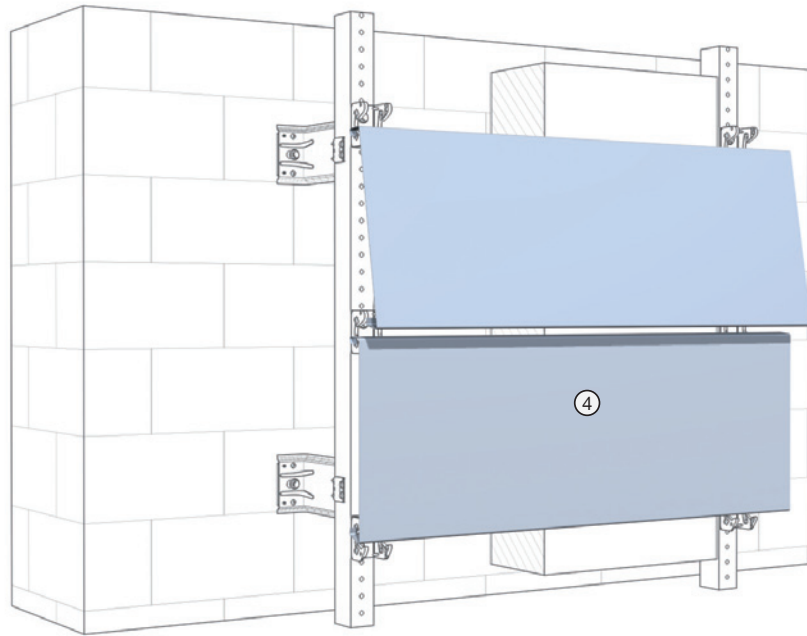

5. During bottom-to-top installation, each panel can be sequentially clicked into the plastic inlays.

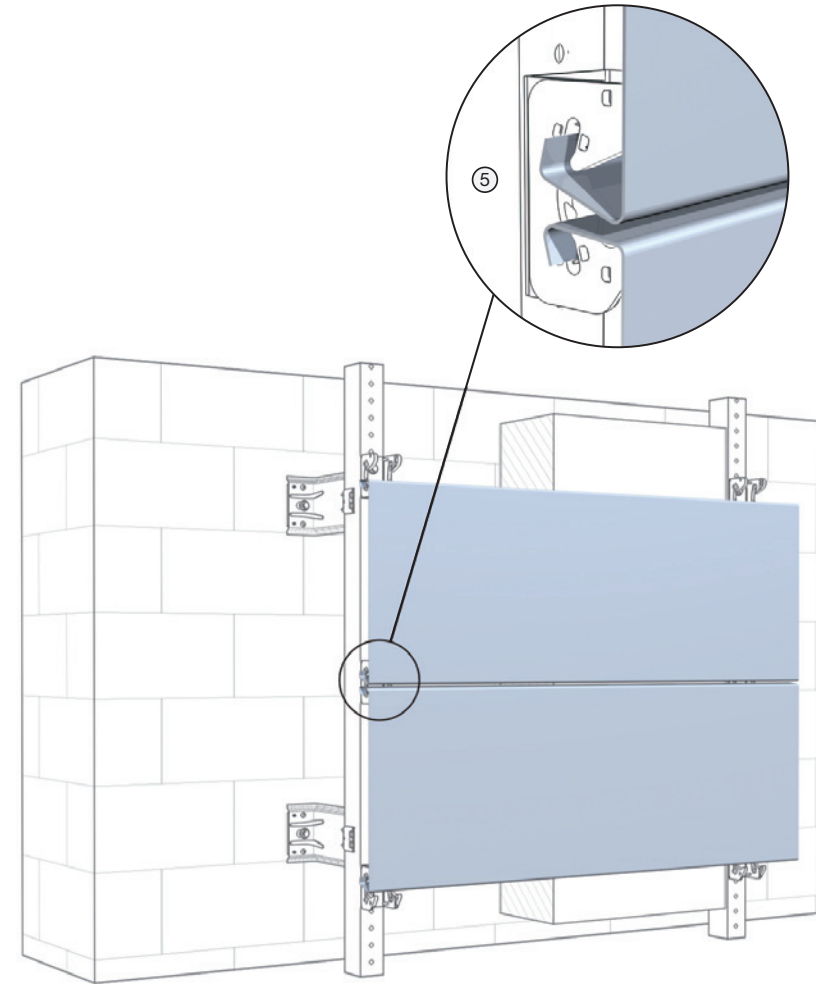

6.2 Panel installation (top to bottom)

In situations where back-lapping of panels on-site is advantageous, such as during the removal of mast climbers or other aerial platforms, the FC panels can be installed from top-to-bottom. Refer to section 6.4 for making the fixed point.

1. Insert the top edge of the upper panel over the lower parts of the plastic inlays. Check the panel can slide freely left to right. Do not click in the bottom edge of the panel at this stage.

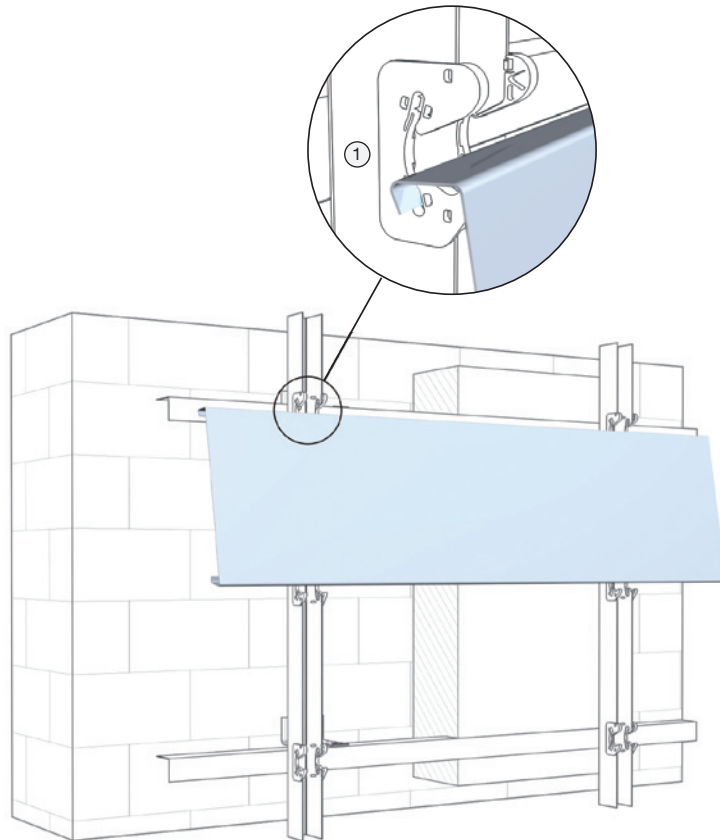

2. Insert the lower panel in place as described in step 1.
3. Return to the upper panel and install and tighten the fixed point clamp and insert guidance snapper(s) (see section 6.4).
4. Repeat step 3 for the lower panel before clicking in the bottom edge of the upper panel.



Caution

Do not click in the bottom edge of the upper panel until the lower panel has been hung in place and a fixed point has been made in the lower panel.

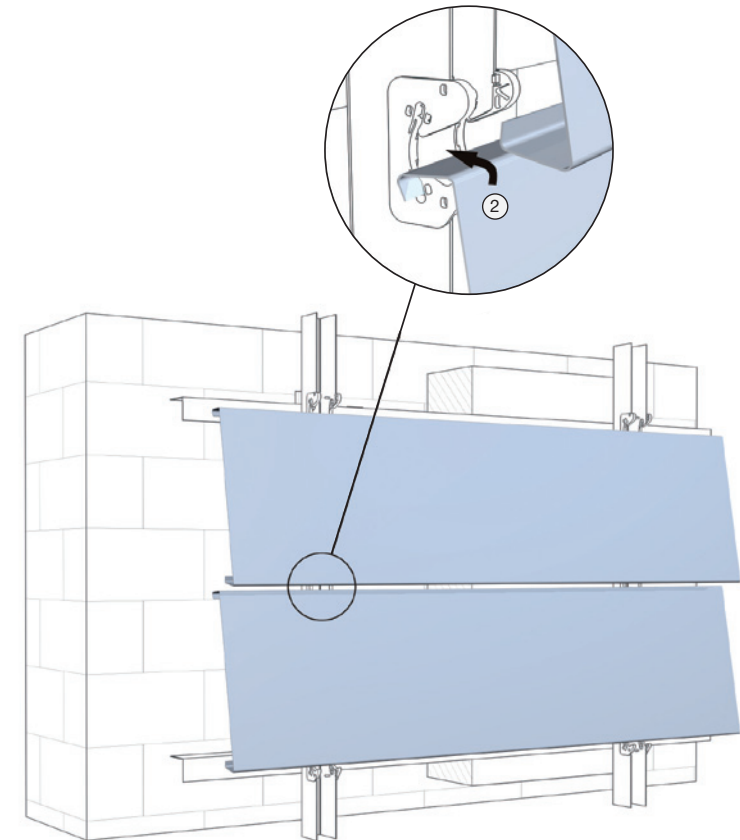

6.3 Vertical panel joints

Vertical panel joints are important for the appearance of the façade. This section should be read together with section 7 on flashing installation which gives a range of possible joint flashings.

Minimum joint width

All vertical panel joints must be a minimum of 10 mm width. This is to ensure there is sufficient space for the panels to expand and contract. For panels longer than 10 m, 1 mm per linear metre gap is normally adequate.

This requirement should be checked according to the local climatic conditions and panel colour/surface finish.

Panel overhangs

To allow sufficient space for flashings to be fixed (either directly to the sub-construction or via the proprietary flashing supports) there should be a minimum of 80 mm distance between the centre of the clicking points and the edge of the panel. The maximum allowable panel overhang is 20% of the panel span unless detailed calculation is used to determine otherwise.

Panel joints with backing flashing

To allow for installation of panels, the maximum overall depth of joint backing flashings is 13 mm.

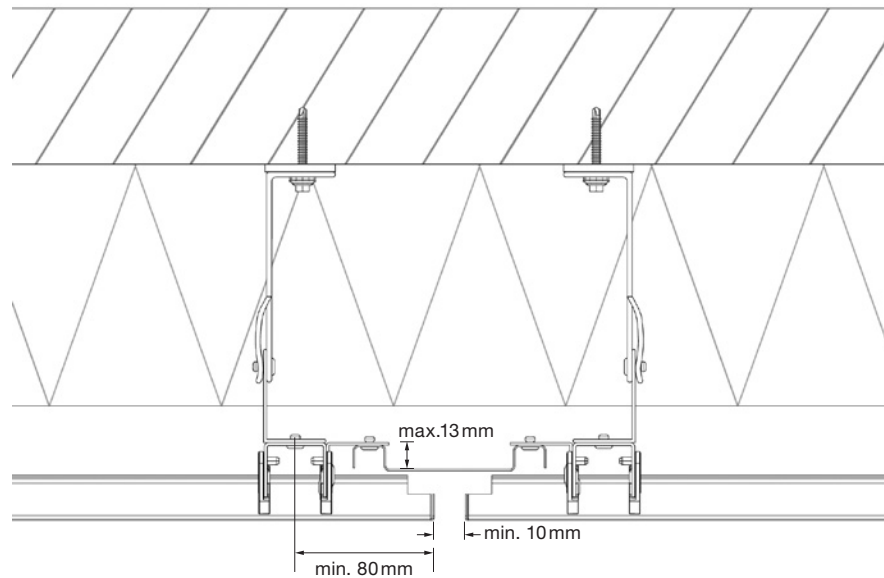

Panel joints with protruding flashings

For vertical joints which include flashings separating the edges of adjacent panels, the minimum joint width should be 10 mm either side of the flashing.



Note

For this type of flashing design option, to ensure even vertical panel joint appearance, consideration can be given to installing the fixed point clamp centrally along the panel length.



A single mono-click bracket or modular click rail must **never** be used to support two FC panels.

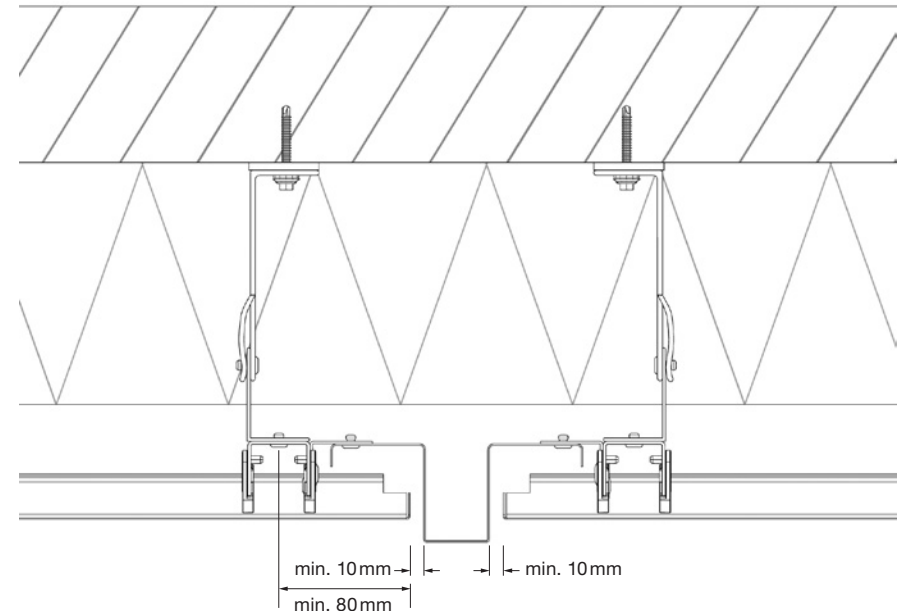
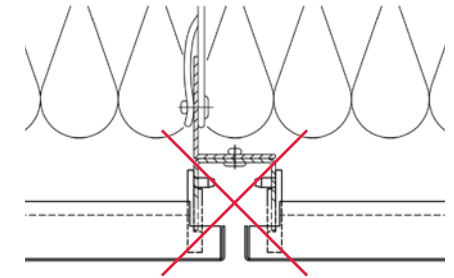

6.4 Fixed points

Every FC panel must have one fixed point to stop the panel sliding out of place during thermal movement. This is achieved using the proprietary fixed point clamp supplied with the system.

Fixed point location

The fixed point clamp is normally positioned in the centre of straight panels to divide the thermal movement equally left and right. The fixed point can be positioned at other locations along the panel length subject to adjacent details/interfaces.

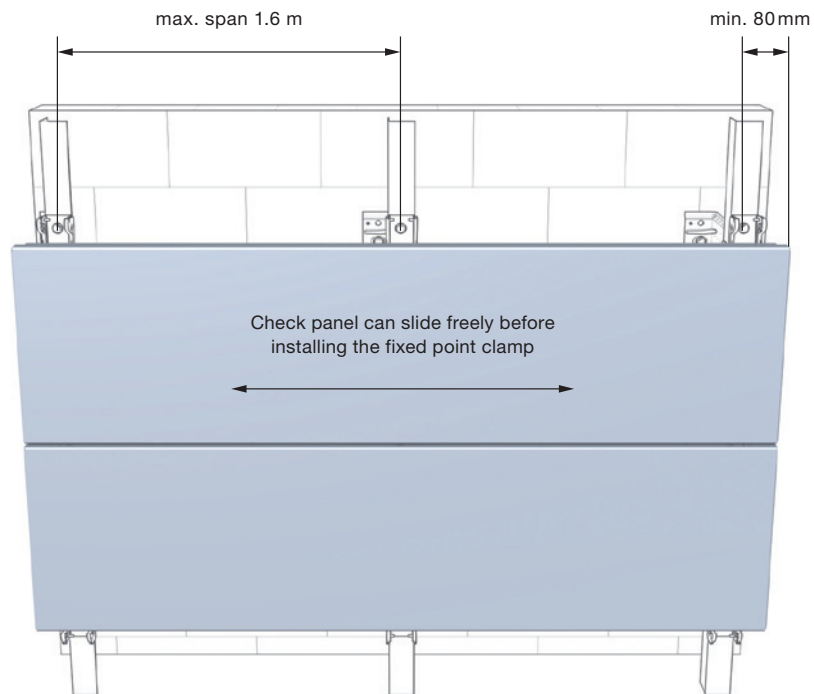

Installation sequence

Before making the fixed point, check that the panel slides freely left-to-right in the plastic inlays. Make sure the panel is in the correct horizontal position in relation to flashings or adjacent panels.

After the lower panel is installed, the fixed point clamp is inserted between the plastic inlays and clips over the two internal pins in the top of the inlays. When the clamp is in position, screw until hand-tight using a \varnothing 3 mm Allen head screwdriver.

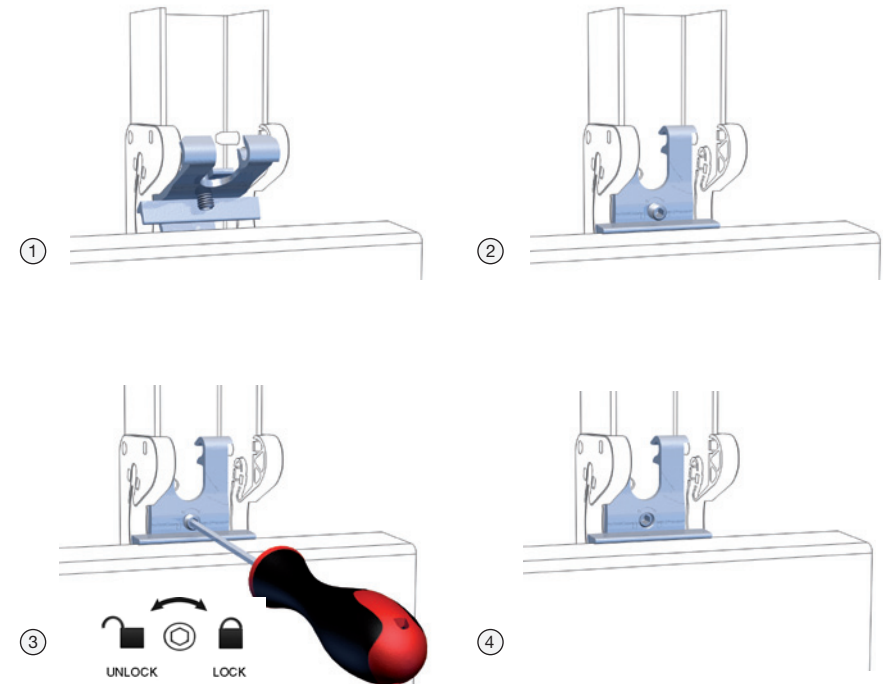

Note

The fixed point clamp in any panel should be tightened before the bottom edge of the panel above can be clicked in.



Caution

Take care not to overtighten the grub screw into the clamp.

6.5 Adjustment of panel position

After the FC panels have been installed and fixed points have been made, it is possible to re-adjust the position of the panels as shown below.

1. Horizontal misalignment of lower panel.
2. Wedge upper panel either side of fixed point with 4 mm shims.

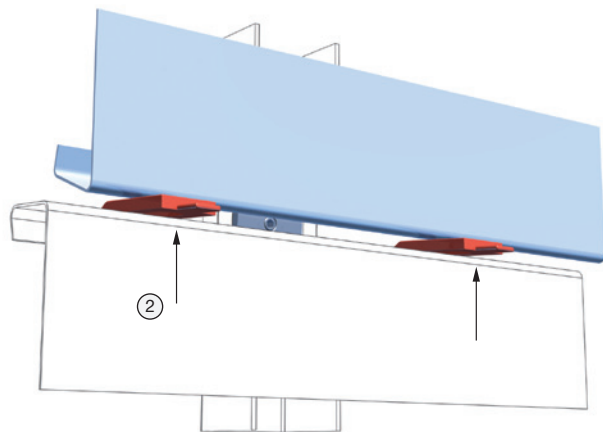
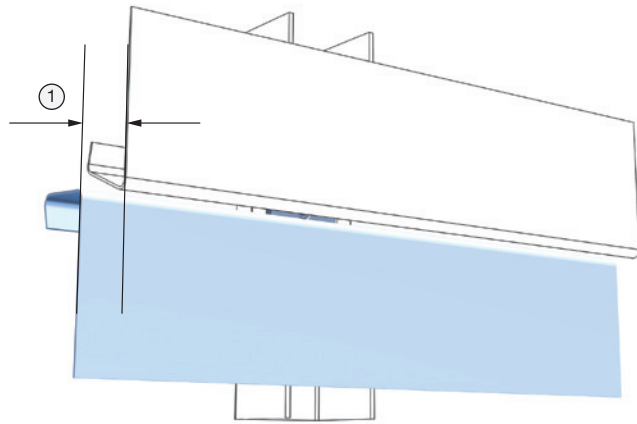

3. Unlock fixed point clamp with \varnothing 3 mm Allen head screwdriver.

4. Align lower panel to correct position

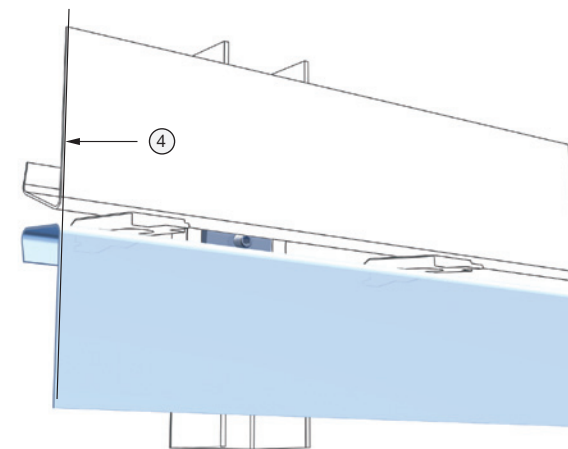
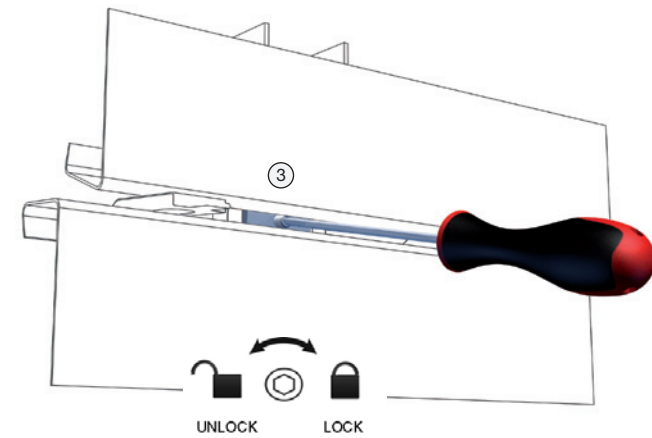

5. Relock fixed point clamp hand-tight 6. Remove wedges to return upper panel to original vertical position

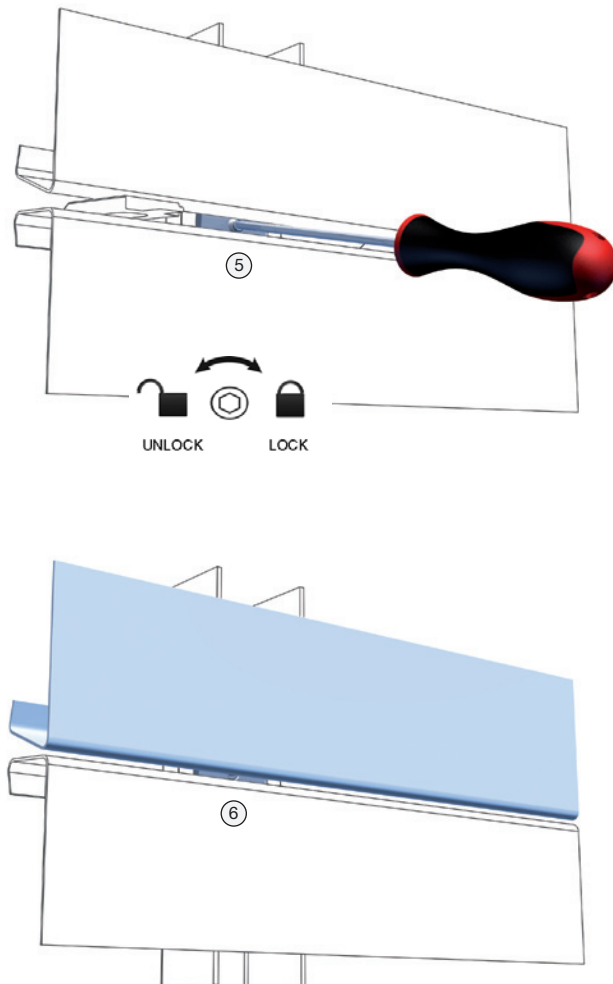

6.6 Corner panels

When no flashing is wanted at the corners, symmetric and non-symmetric internal and external corner FC panels can be supplied to order. This section gives details on the correct installation methods.

Panel supports

Special attention must be paid to the installation of corner panels. A panel support point must be positioned a minimum of 80 mm and a maximum of 20% of the length of that side of panel

taken from the corner (A). For corner panels with unequal length sides, the corner support point should be positioned on the long side of the panel. At both ends of the panel, a support point must also be positioned a minimum of 80 mm and maximum of 20% of the length of that side of the panel from the panel edges (B). This requirement applies whether the sides of the panel are unequal or not. See drawing on page 62.

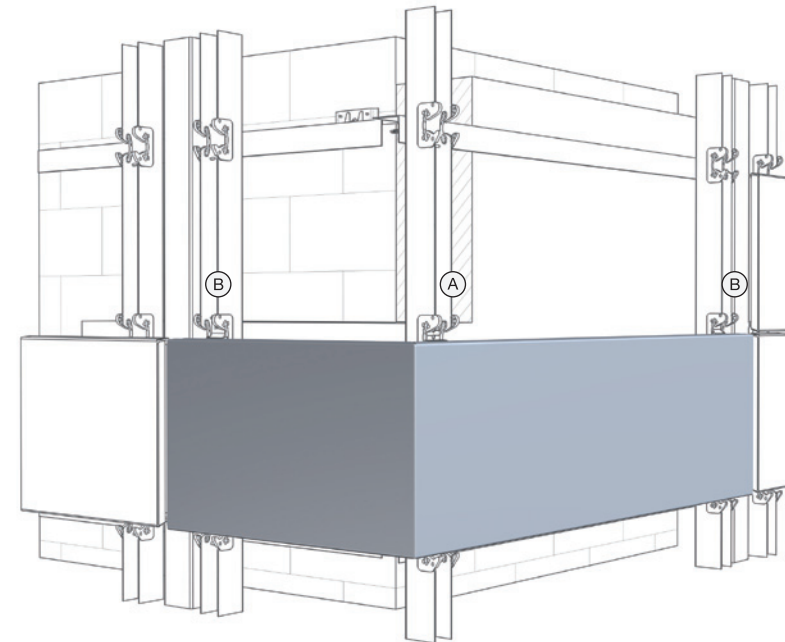

Corner panel fixed point

A fixed point clamp must be installed at the support point located at the corner of the panel.

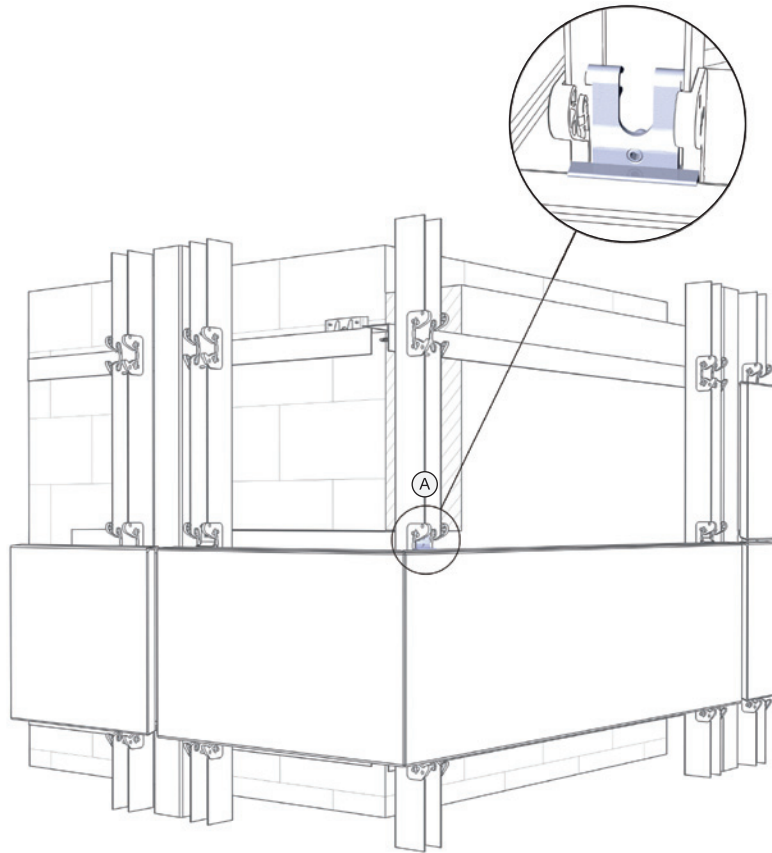

Corner panel guidance snapper

Guidance snappers should be installed at the support points at both ends of the panel. This is to ensure that the panels are properly engaged on both

sides. The guidance snapper is simply clipped over the pins at the top of the plastic inlay.

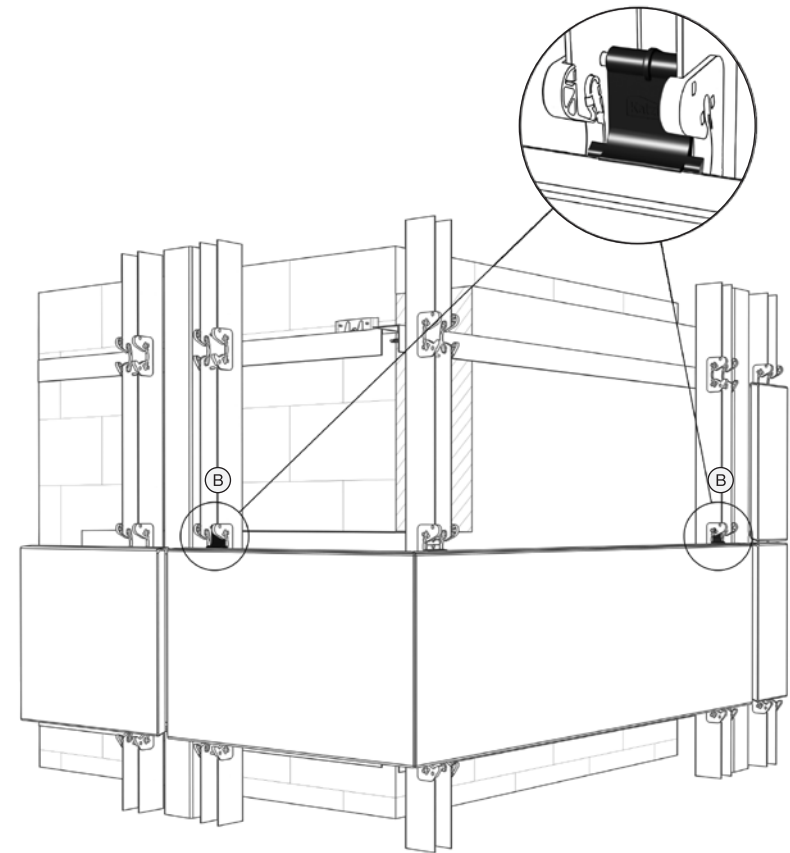

Corner panels (plan view)

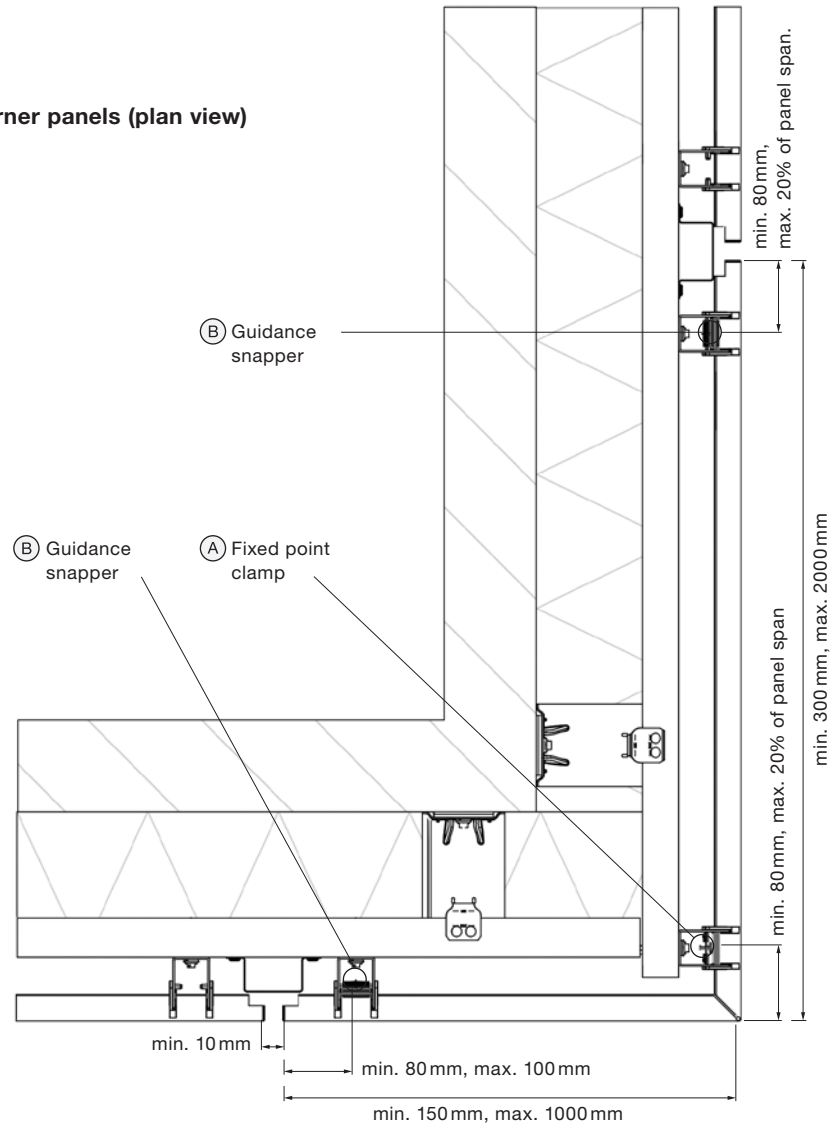

Note

For information on double-corner panels please refer to the separate information sheet.

7.0 Flashing installation

Fixing flashings between panels is made fast and easy using the proprietary flashing support accessory. This component clicks into pre-punched holes in the modular click rails without the need for any additional fixings and provides a flat self-aligned surface to which flashings can be screwed or riveted.

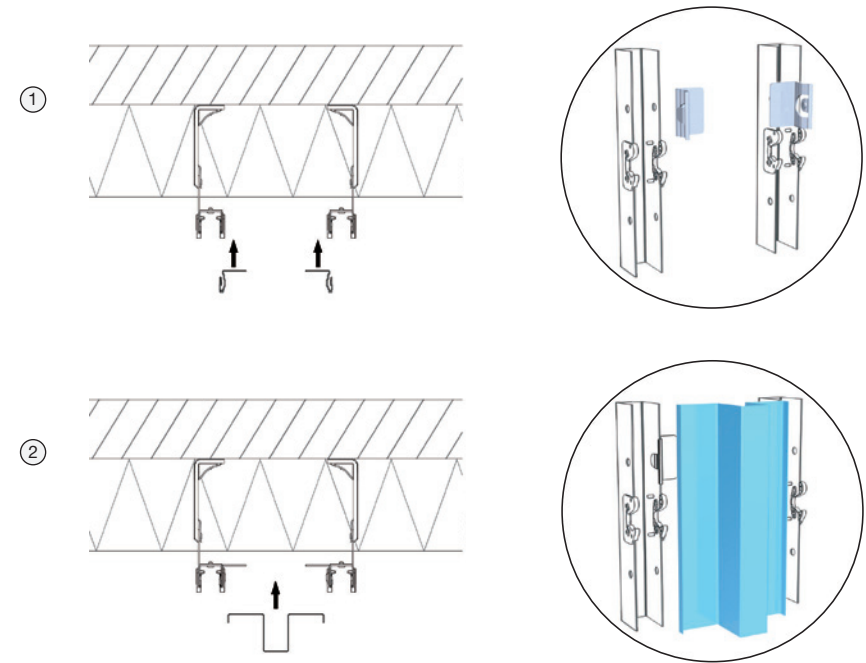
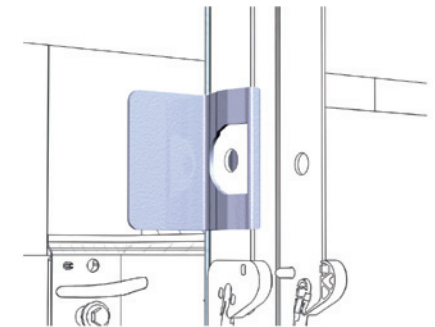

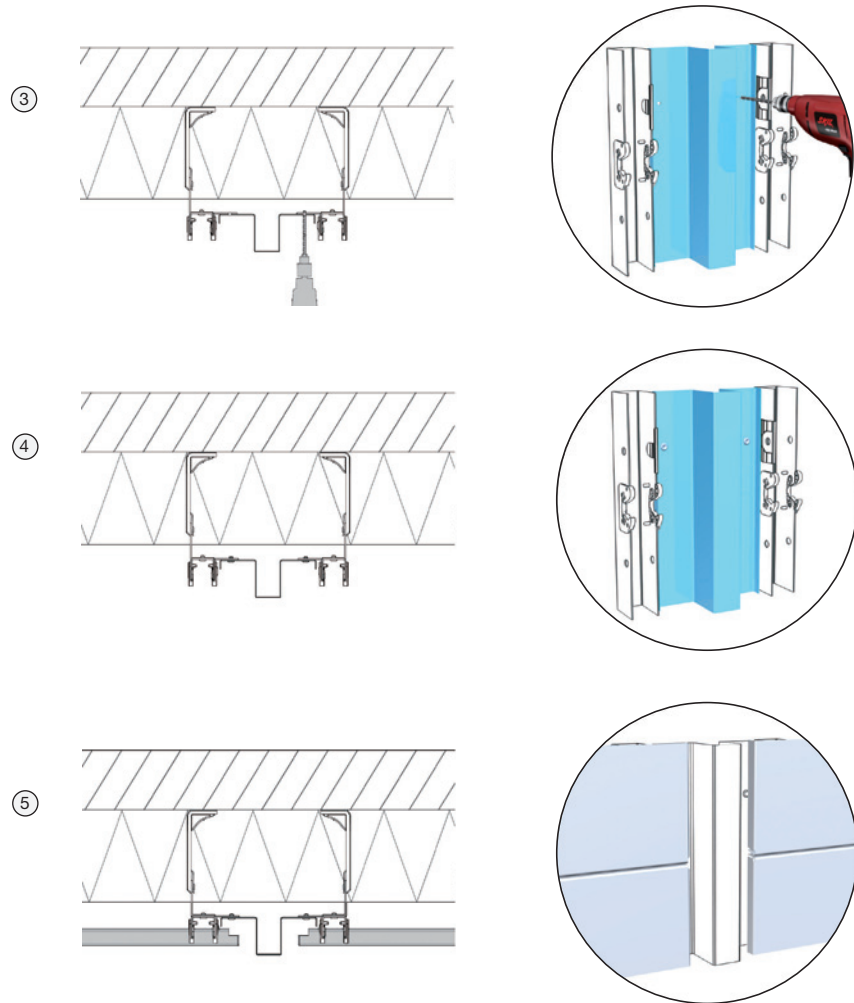

! Note

The flashing support should never be used to fix modular click rails to the sub-construction.

8.0 Panel replacement and tools

In the event of wall damage, the FC façade click system allows individual panels to be replaced without the need to demount the complete façade.

Individual panels can be removed quickly and easily using the specially developed panel removal tools available in the Kalzip FC Toolkit.

! Caution

For the handling and removal of panels it is always necessary to wear adequate protective clothing, in particular safety shoes and protective gloves.



1. To remove an individual panel from the façade, the panel above it must first be unclicked at its lower edge. When using the panel removing tool with round grip, the panel may need to be slid to the one side to create sufficient space to insert the tool into the vertical joint. Insert wedges and unlock the fixed point clamp. Slide the panel to the side and relock the fixed point clamp. Remove the wedges.

Note



- Unclicking the panel is easier when the fixed point clamp is locked
- When using the flat panel removal tool, widening of the vertical joint is not normally required provided it is a minimum of 10 mm.

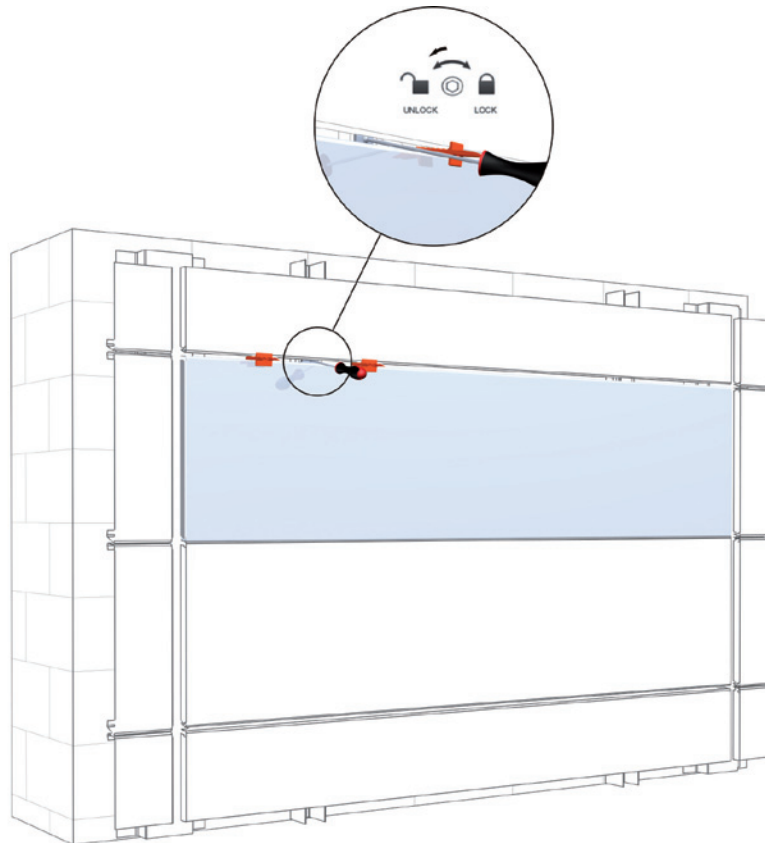

2. If using the round grip removal tool, insert it into the widened vertical joint at the bottom edge of the panel above that to be removed and rotate it into the horizontal joint (detail A).

Slide along to the first unclicking position. If using the flat grip removal tool the same operation can be achieved without the need to move the panel to the side (detail B).

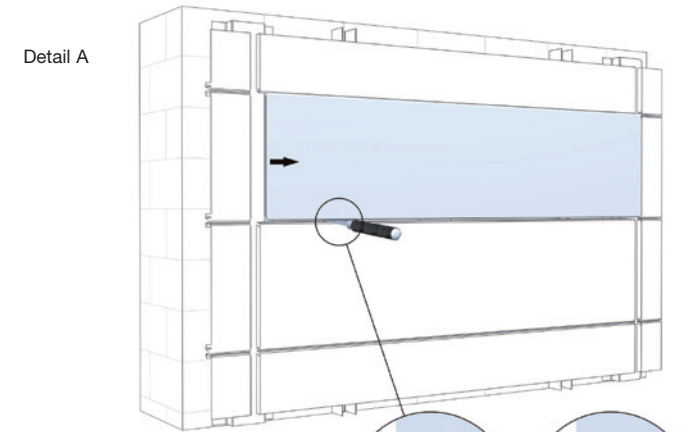

Detail B

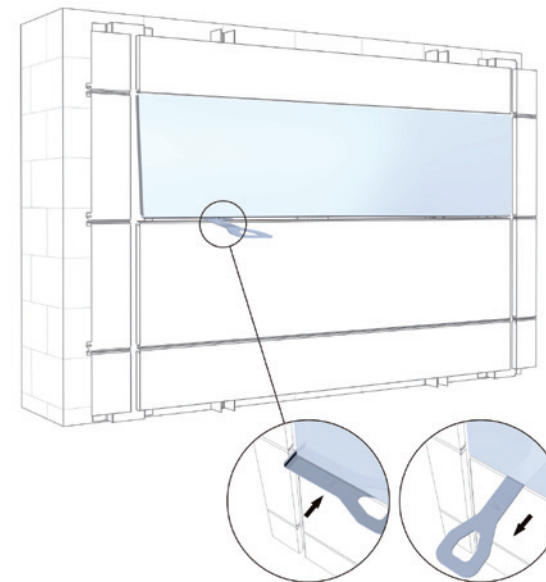

Note

To insert the flat grip panel removal tool without moving the panel to the side, the vertical joint width must be a minimum of 10 mm.

3. Use the panel removal tool (round or flat grip) to release the lower panel edge out of the hooks.

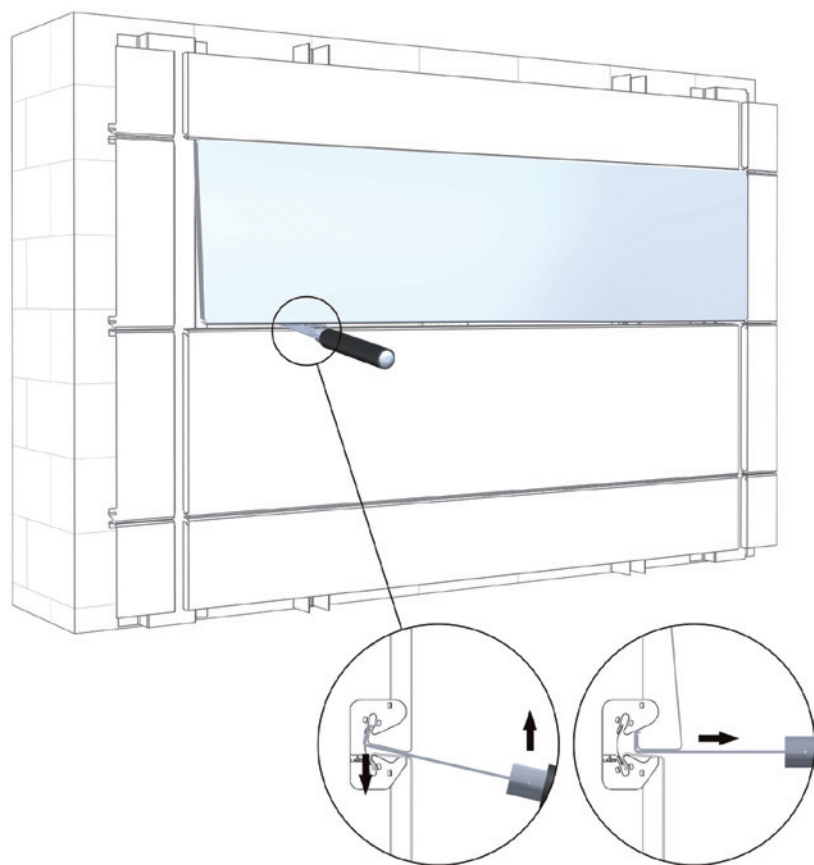

4. Slide the panel removal tool along to the next unclicking position and repeat step 3 until the bottom edge of the panel is completely free from the supports.

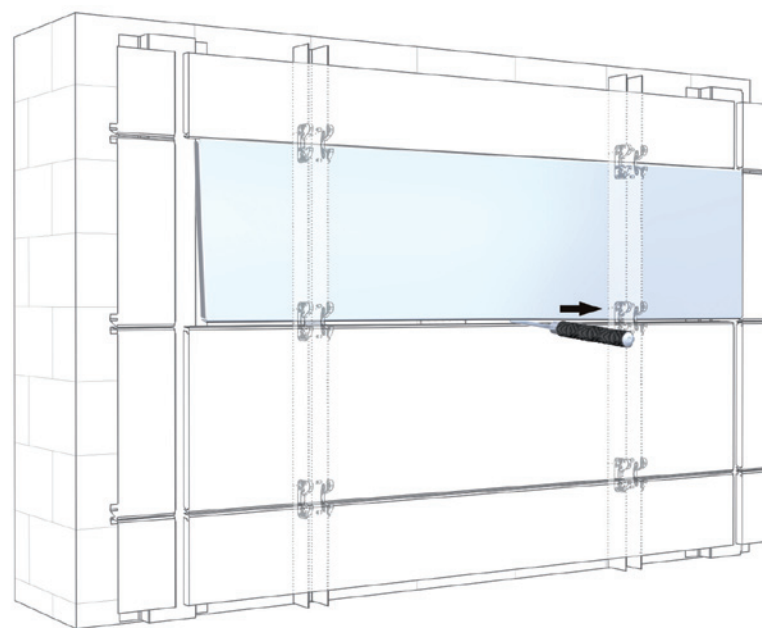

5. Repeat 1 to 4 for the panel to be removed.

6. Remove the fixed point clamp and guidance snapper(s) from the panel to be removed.

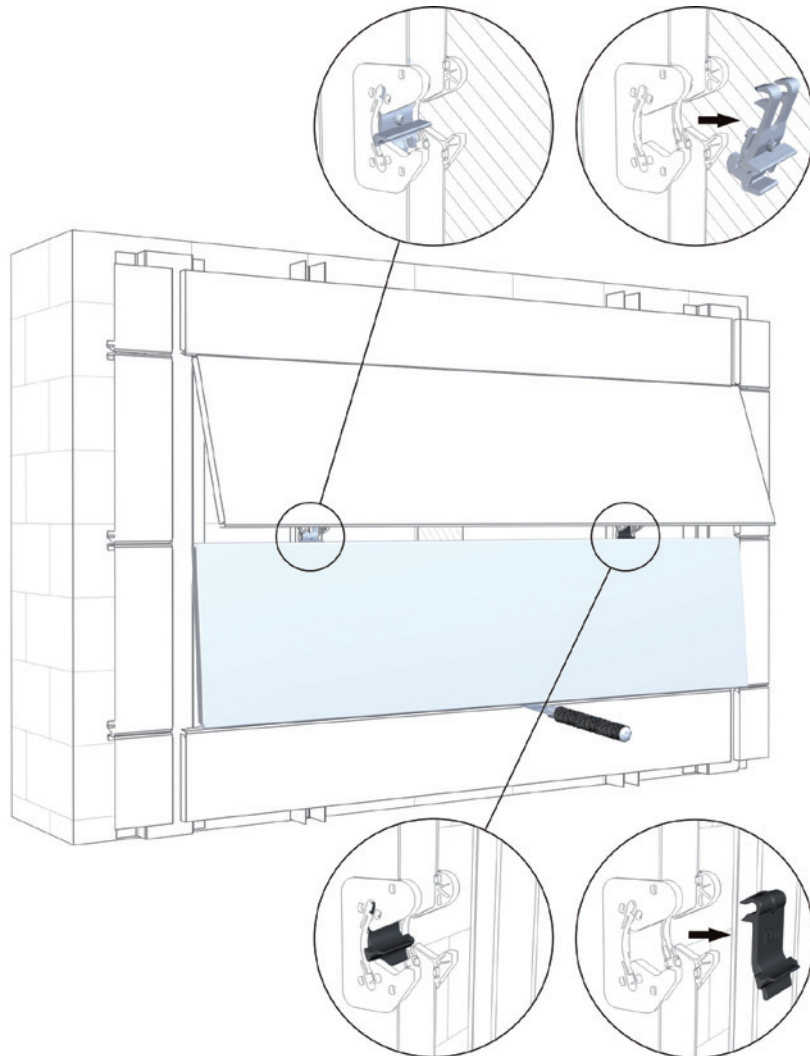

7. Remove the panel. For safety under wind loading, the upper panel should always be clicked in and have its fixed point clamp locked.

8. Insert replacement panel and follow the bottom-to-top installation sequence shown in section 6.1 (page 46).



Note

With care, the same panel can be removed and reinstalled later if access is required to the rainscreen cavity for maintenance.

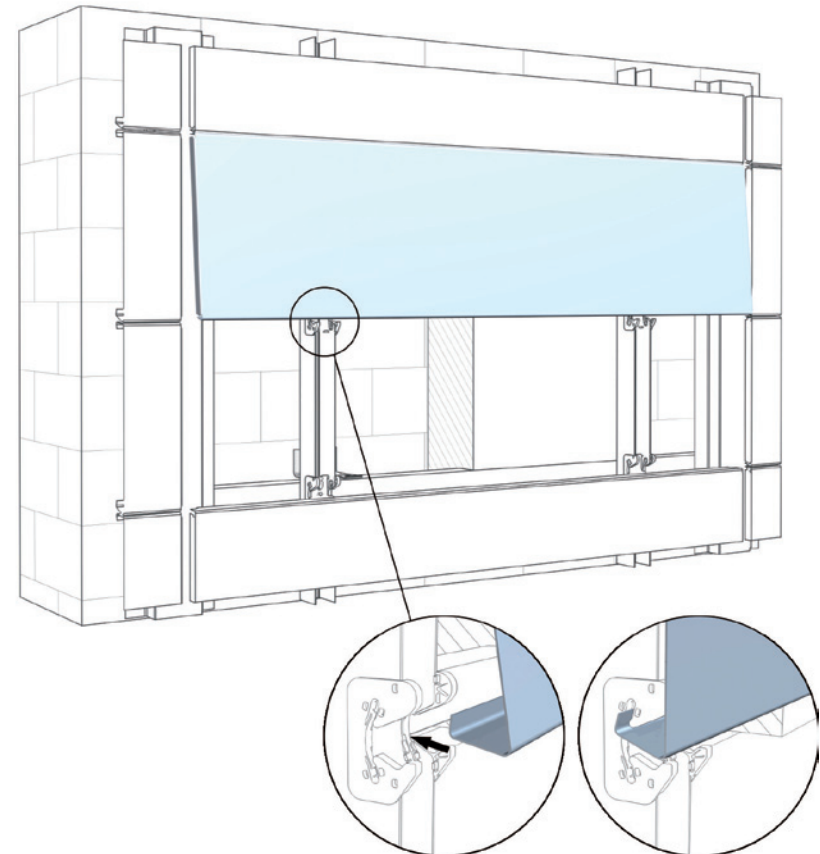

www.kalzip.com

The product and technical information contained in this document is accurate according to our knowledge at the time of publication. Details do not refer to any specific application and cannot give rise to any claim for compensation. From time to time our product range may alter as a result of our continued commitment to product innovation and development. Kalzip cannot guarantee that printed literature will contain the most recent updates; the latest editions are available to download at www.kalzip.com.

Copyright 2014

Kalzip GmbH
Part of Tata Steel Europe Ltd.

Kalzip GmbH
Kalzip GmbH
August-Horch-Str. 20-22 · D-56070 Koblenz
P.O. Box 100316 · D-56033 Koblenz
T +49 (0) 261 - 98 34-0
F +49 (0) 261 - 98 34-100
E germany@kalzip.com

English

The address of your nearest local sales office
can be found on our website: www.kalzip.com