

POST HOLE DIGGER

Operation Manual



TABLE OF CONTENTS

SECTION/PARA	PAGE
Safety Precautions.....	2
I INTRODUCTION & DESCRIPTION	4
1-1 Introduction	4
1-2 Description.....	4
II Operating Instructions.....	5
2-1 General Safety.....	5
2-2 Attaching To Tractor	6
2-3 Transporting.....	6
2-4 Operation	7
2-5 Dislodging Auger	8
2-6 Parking Stand Operation	9
III MAINTENANCE	9
3-1 Maintenance Check List	9
3-2 Lubrication.....	10

RETAIL CUSTOMER'S RESPONSIBILITY UNDER THE WARRANTY

It is the Retail Customer and/or Operator's responsibility to read the Operator's Manual, to operate, lubricate, maintain and store the product in accordance with all instructions and safety procedures. Failure of the operator to read the Operator's Manual is a misuse of this equipment.

It is the Retail Customer and/or Operator's responsibility to inspect the product and to have any part(s) repaired or replaced when continued operation would cause damage or excessive wear to other parts or cause a safety hazard.

It is the Retail Customer's responsibility to deliver the product to the authorized Dealer, from whom he purchased it, for service or replacement of defective parts which are covered by warranty.

It is the Retail Customer's responsibility for any cost incurred by the Dealer for traveling to or hauling of the product for the purpose of performing a warranty obligation or inspection.

IMPORTANT SAFETY PRECAUTIONS



This symbol is used to call attention to safety precautions that should be followed by the operator to avoid accidents. When you see this symbol, carefully read the message that follows and heed its advice. Failure to comply with safety precautions could result in serious bodily injury.

In addition to the design and configuration of equipment, hazard control and accident prevention are dependent upon the awareness, concern, prudence and proper training of personnel in the operation, transport, maintenance and storage of equipment. Lack of attention to safety can result in accident, personal injury, reduction of efficiency and worst of all—loss of life. Watch for safety hazards and correct deficiencies promptly. Use the following safety precautions as a general guide to safe operations when using this machine. Additional safety precautions are used throughout this manual for specific operating and maintenance procedures. Read this manual and review the safety precautions often until you know the limitations.

THE TRACTOR

1. Read the tractor operator's manual to learn how to operate your tractor safely. Failure to do so could result in serious injury or death and equipment damage.
2. It is recommended that tractor be equipped with Rollover Protective System (ROPS) and a seat belt be used for all PHD operations.

3. Add wheel ballast for stability.
4. Move wheels to the tractor manufacturer's widest recommended settings to increase stability.
5. Stop tractor engine, place transmission in park (or neutral), engage parking brake, lower post hole digger to ground, cycle all hydraulic controls to relieve pressure, allow machine moving parts to stop, remove ignition key to prevent unauthorized person from starting engine before dismounting tractor or servicing, repairing, or making adjustments to the equipment.
6. Wear personal protective equipment (PPE), such as, but not limited to, protection for eyes, ears, lungs, head, hands and feet when operating, servicing, or repairing equipment. Avoid wearing loose clothing or jewelry that may catch and entangle on equipment moving parts.
7. Use sway bars, sway chains or rigid stabilizers to eliminate the 3 point hitch linkage sway and to stabilize post hole digger behind the tractor. As viewed from behind tractor, the 3 point lift arms should be adjusted to position the auger vertically.
8. Never use alcoholic beverages or drugs which can affect alertness or coordination while operating equipment.

THE POST HOLE DIGGER

1. Read the PHD Operator's Manual. Any person who has not read and understood all operating safety instructions is not qualified to operate this machine. Failure to do so could result in serious injury or death and equipment damage.
2. Become familiar with all the machine's controls and all the caution, warning and danger decals affixed to the machine before attempting to start or operate.
3. Do not allow children to operate PHD. Do not allow adults to operate PHD without proper instructions.
4. Before starting or operating the machine, make a walk around inspection and check for obvious defects such as loose, damaged or worn components. correct any deficiency before starting.
5. Do not operate without all guards and shields in place and in good condition.
6. Do not operate with worn, broken or missing auger point and cutting blades.
7. Avoid serious injury or equipment damage by replacing spent shear bolts or pins with Bush Hog specified size and grade shear bolts or pins.
8. Never use unspecified long pins, bolts, or bars to replace driveline shear bolts, pins or auger bolts. Avoid serious injury or death from entanglement in this long protruding part and damage to driveline, gearbox or auger.
9. Clear the work area of objects which might be picked up, thrown or be entangled in the auger.
10. Keep the area of operation clear of all persons particularly small children and pets. Stop operation whenever any one comes within the operating area.
11. Never operate PHD with anyone near or in contact with the PHD, PTO driveline, or auger.
12. Keep body parts, hands and feet clear of auger, PTO driveline and gearbox during operation.
13. Do not transport persons on tractor or PHD.
14. Do not use body weight to force PHD auger into ground during digger operation or locate auger when turning.
15. Shut off power and stop auger when transporting.

16. Do not raise PHD more than 12 inches off the ground with the tractor PTO engaged.
17. Consult local utility companies before digging to make certain there is no buried gas lines, water lines, electrical cables, etc., in the work area.

EMPLOYEE TRACTOR OPERATING INSTRUCTIONS:

1. Securely fasten your seat belt if the tractor has a ROPS.
2. Where possible, avoid operating the tractor near ditches, embankments, and holes.
3. Reduce speed when turning, crossing slopes, and on rough, slick, or muddy surfaces.
4. Stay off slopes too steep for safe operation.
5. Watch where you are going, especially at row ends, on roads, and around trees.
6. Do not permit others to ride.
7. Operate the tractor smoothly - no jerky turns, starts, or stops.
8. Hitch only to the drawbar and hitch points recommended by tractor manufacturers.
9. When tractor is stopped, set brakes securely and use park lock if available.

SECTION I INTRODUCTION AND DESCRIPTION

1-1 INTRODUCTION

Your Post Hole Digger has been carefully designed to give maximum service with minimum down time. This manual is provided to give you the necessary operating and maintenance instructions for keeping your post hole digger in top operating condition. Please read this manual thoroughly. Understand what each control is for and how to use it. Observe all safety precautions decaled on the machine and noted throughout the manual for safe operation or implement. If any assistance or additional information is needed, contact your authorized dealer.

NOTE

All references made in this manual to right, left, front, rear, top, or bottom is a s viewed facing the direction of forward travel with implement properly attached to tractor.

1-2 DESCRIPTION

The post hole digger mounts to the tractor three-point hitch and is powered by the PTO drive.

Power from the PTO is transmitted through a reduction gearbox to the auger.



Major Components

- Boom
- Gearbox
- Flighting
- Auger Point
- Cutting Blades
- Shield
- Driveline
- Hitch Pins
- Mast

SECTION II

OPERATING INSTRUCTIONS

2-1 GENERAL SAFETY

Only qualified people should operate this machine. Operator should wear safety

glasses, safety shoes, and work gloves. It is recommended that tractor be equipped with Rollover Protective System (ROPS) and a seat belt be used. Before beginning operation, clear work area of objects that could wrap around auger. Check for ditches, stumps, holes, or other obstacles that could upset tractor. Always turn off tractor engine, set parking brake, and allow auger to come to a complete stop before dismounting tractor.

2-2 ATTACHING TO TRACTOR

A. Attach tractor lift arms to post hole digger mast.

B. Remove tractor 3-Point hitch top link. Pin boom into tractor top link hole. When the boom is fully raised, there should be adequate clearance between the auger point and the ground for transporting. After attaching to your tractor 3-point hitch, the pivot pin may need to be repositioned.

C. Pull driveline apart. Attach free end to tractor PTO shaft.

D. Raise and lower post hole digger to determine position with greatest distance between PTO shaft and gearbox input shaft. Shut down tractor leaving implement in position of greatest distance.

E. Hold driveline sections parallel to each other and check for minimum 6 inches (15 cm) overlap.

If driveline has less than minimum overlap, do not use. Contact authorized dealer.

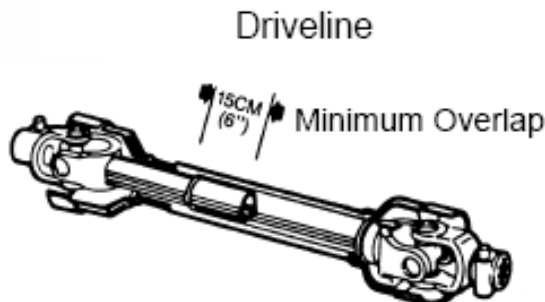

F. Reassemble driveline and attach to tractor.

G. Connect / adjust stabilizer bars, sway chains or equivalent and level lower lift arms. Refer to tractor operator's manual.

2-3 TRANSPORTING

Do not engage tractor PTO drive with post hole digger fully raised to transport position. When implement is transported on road or highway, day or night, use tractor flashing warning lights unless prohibited by law. A slow moving vehicle (SMV) sign must be visible from the rear by approaching vehicles. Do not exceed 15 mph (24 kph).

2-4 OPERATION



WARNING

CONSULT LOCAL UTILITY COMPANIES TO MAKE CERTAIN THERE ARE NO BURIED GAS LINES, ELECTRICAL CABLES, ETC. IN THE WORK AREA BEFORE BEGINNING OPERATION. FAILURE TO DO SO COULD RESULT IN PERSONAL INJURY OR DEATH.

A. Perform BEFORE EACH USE maintenance listed in paragraph 3-1.

B. Make certain all bystanders are clear of tractor and implement. With tractor at idle speed and tip of auger 6 inches (152 mm) above ground, engage tractor PTO drive to give unit a test run. Disengage tractor PTO drive.



CAUTION

NEVER ENGAGE PTO WHEN AUGER POINT IS MORE THAN ONE FOOT (30 CM) ABOVE GROUND.

DANGER

STAND CLEAR OF AUGER AND DRIVE SHAFT WHEN IN OPERATION. FAILURE TO DO SO COULD RESULT IN SERIOUS INJURY OR DEATH.

C. Place auger point at desired location of first hole. Drive tractor forward to create an angle 3" (76 mm) back of center of gearbox. As auger works into ground, the slight angle will straighten due to pivoting action of boom.

Correct Angle for Ground Entry

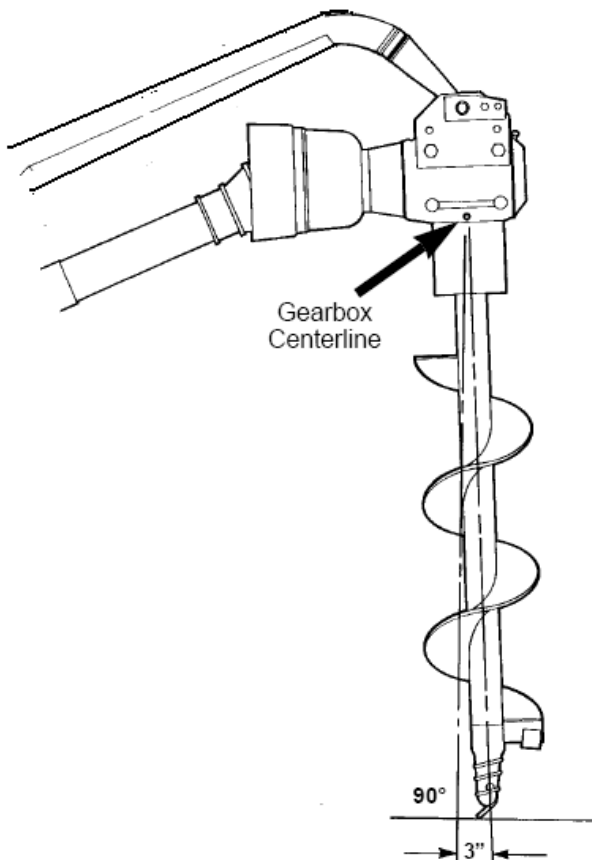

D. (6" - 9" - 12" Augers) With the auger point in the correct position and all bystanders 10 ft. or more from auger, engage PTO with the engine at a little more than idling speed. Move the tractor hydraulic lift arm lever slowly to the down position. Allow the auger to dig until there is an indication of overloading. Raise the auger but do not allow the auger to come completely out of the hole. This allows auger to clean itself of loose soil. Lower the auger into the hole and continue this procedure until the desired depth is reached.

F. If at any time the auger fails to dig, check for the following:

- _ Grass, roots or clay lodged around blades.
- _ Foreign objects such as tin cans or wire hung on blades.
- _ Point or blades loose or excessively worn.
- _ Tractor lift arms not allowing auger to penetrate full depth with ease.

2-5 DISLODGING AUGER



CAUTION

THIS STEP IS DONE ONLY WITH THE TRACTOR SHUT OFF.

If auger becomes lodged on an obstruction below ground, to prevent damage to the yoke and boom, do not attempt to raise auger by hydraulic lift power alone until auger has been turned several revolutions in reverse. A chain wrench may be used on the auger to dislodge from obstruction. After auger is freed, apply lift power and slowly rotate PTO shaft to raise auger.

2-6 PARKING STAND OPERATION

For easier attaching and detaching of your post hole digger, the optional parking stands are very convenient.

First, with the 3-point hitch in the fully raised position, remove the pins from the pipe legs, lower the legs and repin in the lowered position.

Lower the digger point to the ground and slowly drive the tractor forward while lowering the lift arms until the pipe legs and arm weldments contact the ground. Boom and hitch pins may then be disconnected from the tractor.

SECTION III

MAINTENANCE

3-1 MAINTENANCE CHECK LIST

Perform scheduled maintenance as outlined below. Lower implement to ground, turn

off tractor, and set parking brake before doing maintenance inspections or work. All bolts should be torqued as recommended in the torque chart on page 16 unless otherwise indicated.

BEFORE EACH USE

1. Inspect auger to be sure that no foreign objects such as wire or steel strapping bands are wrapped around it.
2. Make certain driveline shields are in place and in good condition.
3. Check cutting blades, point, and flighting for wear or damage. Repair or replace as necessary.
4. Inspect hydraulic components for wear or leaks. Repair or replace as necessary.



WARNING

USE A PIECE OF CARDBOARD OR WOOD RATHER THAN HANDS AND WEAR EYE PROTECTION WHEN SEARCHING FOR HYDRAULIC LEAKS. ESCAPING HYDRAULIC OIL UNDER PRESSURE CAN PENETRATE THE SKIN. IF OIL IS INJECTED INTO SKIN, IT MUST BE SURGICALLY REMOVED WITHIN A FEW HOURS BY A DOCTOR OR GANGRENE MAY RESULT.

5. Perform BEFORE EACH USE lubrication per paragraph 3-2.
6. During operation, listen for abnormal sounds which might indicate loose parts, damaged bearings, or other damage.

AFTER EACH USE

1. Clean all debris from machine.

3-2 LUBRICATION

NOTE

The multi-purpose grease referenced in this section is NLGI Grade 2 type grease.

BEFORE EACH USE

1. Driveline Universal Joints - Apply multi-purpose grease to fittings.
2. Driveline Guard - Apply 2-3 shots of multi-purpose grease to plastic fittings.
3. Driveline Shaft - Disconnect PTO driveline, pull two sections apart, and apply thin coat of multipurpose grease to inside of outer (female) section. Reassemble sections and install. Pull each section to be sure driveline and shields are securely connected. Make sure PTO shielding is in good condition.

40 HOURS

4. Apply multipurpose grease to fitting on shear pin yoke. It is important that this fitting be greased regularly to prevent yoke from seizing to input shaft rendering shear pin useless.

5. Gearbox - Add EP80W-90 gear oil as necessary to bring oil level to check plug.

