

OPERATION MANUAL FOR TZ SERIES TRACTOR FRONTLOADER



CONSUMER NOTICE

Respectable consumer:

Thanks for your trust in our company and buying the front loader produced by our company. In order to use the loader in a right, reasonable and efficient way, please comply the follows:

1. Before use the front loader, you should read the manual carefully regardless you have related experience or not before.

2. Please don't refit the frontloader randomly for fear of affecting its capability or occurring contingency. And at the same time, it might cause the responsibilities related to "Three Guarantee" services can't be fulfilled.

3. Please obey the rules strictly and use the frontloader correctly to gain the largest economical benefit.

All of the information, pictures and technical data in the manual subject to the latest information when the manual published. No further notice will be given for any modification.

Contents

| | |
|--|-----------|
| CONSUMER NOTICE ! | 2 |
| Contents..... | 3 |
| Foreword | 4 |
| NOTES FOR SAFETY | 5 |
| 1 Application, technical performance and technical data | 6 |
| 1.1 Application and feature | 6 |
| 1.2 Main specification and technical data | 6 |
| 2 Main component structure, working principle and operation..... | 9 |
| 2.1 Working device system..... | 9 |
| 2.2 Working device hydraulic system | 9 |
| 2.3 Disassembly and assembly of working device..... | 16 |
| 2.4 Driving and operation..... | 19 |
| 3 Accessories..... | 23 |
| 3.1 Sorts and function | 23 |
| 3.2 Disassembly and assembly of accessories..... | 24 |
| 4 Technical maintenance and common trouble and troubleshooting..... | 25 |
| 4.1 Technical maintenance | 25 |
| 4.2 Trouble and troubleshooting | 25 |

Foreword

TZ Series Tractor Frontloader is used for FOTON Four-wheel Driven Tractors. This manual introduces the structures, working principles, and operation of the frontloader in intelligible words and figures, as well as the maintenance, the common trouble and trouble shooting. If you want to know the operation and the adjustment of the relevant tractor, please consult the “OPERATION MANUAL OF FOTON SERIES WHEELED TRACTORS”.

The frontloader introduced in this manual involves seven series; viz. series 02, series 03, series 04, series 06, series 08, series 10 and series 12. According to the difference between the link structures of the lift arm and the bucket, the lift arm and the vertical column, every series includes five type, that is, the common model, model A, model B, model C and model D.

The frontloader can mount six kinds of working device according to the demand of the work, involving the universal bucket, the assembled bucket, the bars-casing bucket, the pallet fork and the timber grab.

The manual instances the common model, model A, model B, model C and model D for explanation, and introduces the working devices in the end.

NOTES FOR SAFETY

1. The driver must have formal driving license, and be familiar with the use of the frontloader and tractor, and drive, service, maintain the frontloader according to the prescript of the manual.
2. Not allow any one stand under the lift arm and bucket.
3. Never drive at high speed when the bucket is over the transport position.
4. Never drive overloading.
5. Don't load the barycenter of the goods deflected.
6. When parking at a slope, it needs not only strain the hand brake but also fix the wheel with a trilateral wood.
7. Never park close to fire.
8. Pay attention to the readings of instruments at any time.
9. Disassemble, assemble and adjust machine according to the manual.
10. Check whether the brake system is safe and reliable. Otherwise, don't drive until eliminate all malfunctions.

1 Application, technical performance and technical data

1.1 Application and feature

TZ-D Series Tractor Frontloader is a kind of mini-type engineering machine fixed on tractors and used for loading. The frontloader can be used in a family, farm, storehouse, etc. where the large-scale models are not so available, for transporting incompact materials such as scarification, sandrock, coal, waste, etc., as well as shoving soil, digging, piling, etc.

1) The frontloader, with hydraulic transmission technique and compact structures, is flexible and available in narrow spots where the large-scale machine can not.

2) It is fixed on the four-wheel driven tractor that has full hydraulic steering and a batch production, with compact structures and reliable transmitting.

3) One hydraulic system is used by the frontloader and the tractor's lifting device together, which accords to GB and easy to maintain.

4) The frontloader can mount various devices according to different demands.

1.2 Main specification and technical data

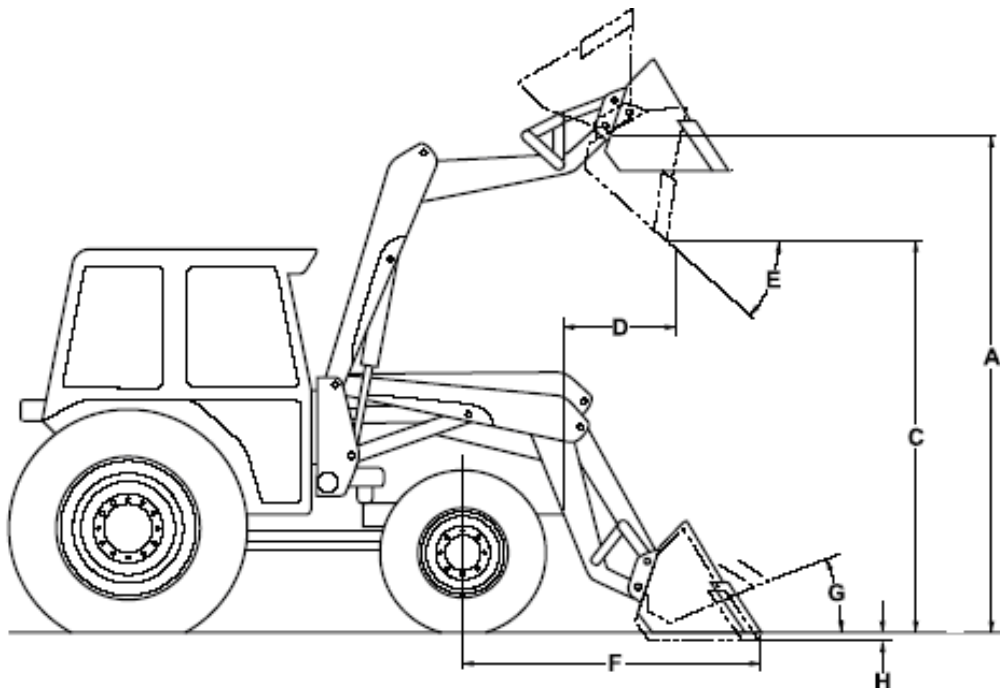

Fig. 1-1 Sketch of the frontloader fixed on Foton Tractors

Technical Data Collection List of the frontloader fixed on Foton Tractors

(unit mm)

| | Series 02 | | | | | Series 03 | | | | |
|---|-----------|-------|-------|-------|-------|-------------------|-------|-------|-------|-------|
| Model | TZ02 | TZ02A | TZ02B | TZ02C | TZ02D | TZ03 | TZ03A | TZ03B | TZ03C | TZ03D |
| Matching tractor | FT254 | | | | | FT304/FT354/FT404 | | | | |
| Max lift <u>height of measured at arm pivot point</u> (A) | 2100 | | | | 2360 | 2400 | | | | 2700 |
| Max.dump height (C) | 1700 | | | | 1800 | 2000 | | | | 2000 |
| Dump distance (D) | 600 | | | | 700 | 800 | | | | 900 |
| Dump angle (E) (°) | 45° | | | | 45° | 42° | | | | 45° |
| Distance of bucket to the centre of front-wheel(F) | 1560 | | | | 1820 | 1830 | | | | 1930 |
| Rollback angle on ground (G) (°) | 26 | | | | 32 | 26 | | | | 32 |
| Max. digging depth (H) | 100 | | | | 100 | 100 | | | | 140 |
| Bucket width | 1289 | | | | 1289 | 1482 | | | | 1482 |
| Bucket capacity (m ³) | 0.18 | | | | 0.18 | 0.2 | | | | 0.2 |
| Rated lift capacity (Kg) | 200 | | | | 200 | 300 | | | | 300 |

| | Series 04 | | | | | Series 06 | | | | |
|-------|-----------|-------|-------|-------|-------|-----------|-------|-------|-------|-------|
| Model | TZ04 | TZ04A | TZ04B | TZ04C | TZ04D | TZ06 | TZ06A | TZ06B | TZ06C | TZ06D |

| Matching tractor | FT454/ FT504A | | | | | FT554/FT604/FT704 | | | | |
|---|---------------|--|--|--|------|-------------------|--|--|--|------|
| Max. lift height— measured at arm pivot point (A) | 2500 | | | | 2800 | 2700 | | | | 3100 |
| Max. dump height (C) (mm) | 2100 | | | | 2100 | 2300 | | | | 2300 |
| Dump distance (D) | 800 | | | | 900 | 1180 | | | | 1140 |
| Dump angle (E) (°) | 42° | | | | 45° | 42° | | | | 45° |
| Distance of bucket to the centre of front- wheel (F) | 1830 | | | | 1930 | 2000 | | | | 2320 |
| Rollback angle on ground (G) (°) | 26 | | | | 32 | 27 | | | | 34 |
| Max. digging depth (H) | 100 | | | | 140 | 110 | | | | 140 |
| Bucket width | 1542 | | | | 1542 | 1652 | | | | 1652 |
| Bucket capacity (m ³) | 0.21 | | | | 0.21 | 0.43 | | | | 0.43 |
| Rated lift capacity (Kg) | 400 | | | | 400 | 600 | | | | 600 |

| | Series 08 | | | | | Series 10 | | | | |
|---|----------------------------|-------|-------|-------|-------|-----------|-------|-------|-------|-------|
| Model | TZ08 | TZ08A | TZ08B | TZ08C | TZ08D | TZ10 | TZ10A | TZ10B | TZ10C | TZ10D |
| Matching tractor | FT754A/FT804A/ FT824/FT904 | | | | | FT1004 | | | | |
| Max. lift height— measured at arm pivot point (A) | 3250 | | | | 3080 | | | | | |
| Max. dump | 2500 | | | | 2350 | | | | | |

| | | | | | | | | | | |
|---|------|--|--|--|------|-----|--|--|--|-----|
| height (C) | | | | | | | | | | |
| Dump distance (D) | 1020 | | | | 1100 | | | | | |
| Dump angle (E) (°) | 42° | | | | 43° | 42° | | | | 42° |
| Distance of bucket to the centre of front-wheel (F) | 2200 | | | | 2400 | | | | | |
| Rollback angle on ground (G) (°) | 28 | | | | 33 | | | | | |
| Max. digging depth (H) | 160 | | | | 180 | | | | | |
| Bucket width | 1700 | | | | 1800 | | | | | |
| Bucket capacity (m ³) | 0.46 | | | | 0.46 | | | | | |
| Rated lift capacity (Kg) | 1000 | | | | 1000 | | | | | |

Notice: No further informing will be given for any modification of the data.

2 Main component structure, working principle and operation

2.1 Working device system

The working device system is the component contributing directly to loading like arms of a person. As shown in Fig.2-1, the working device consists of bucket, vertical column, lift arm, and underframe, etc.

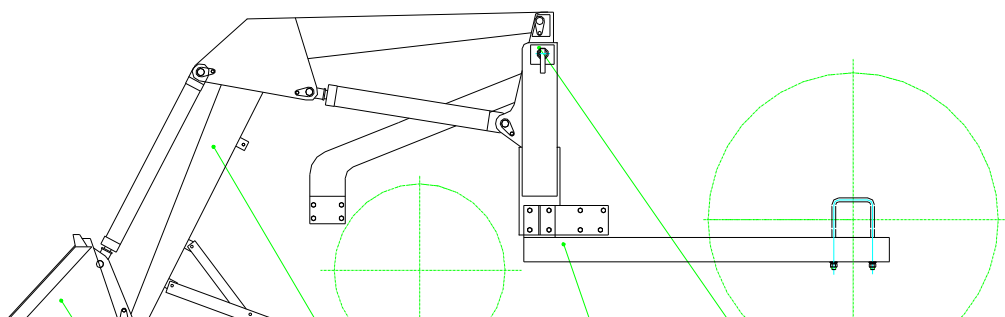

Fig.2-1 Working Device Sketch

According to the difference between the linking structures of the lift arm and the bucket, the lift arm and the vertical column, the frontloader includes five models. That is the Common model, model A, model B, model C and model D.

2.1.1 Common model (As shown in Fig.2-2)

For the Common model, the vertical column links to the tractor fixedly, the lift arm and the lift cylinder links to vertical column by fixed pins. If necessary, take out the fixed pins, put down the support leg, loosen the quick release coupling of the oil pipes, and then the lift arm will be separated from the vertical column, the frontloader will be separated off. The teeth are mounted on the edge blade of the bucket by bolts, and the teeth can be replaced when worn out. The edge blade can also be cut off to replace when worn out. Various working device can be replaced according to the work demand?assembling bucket, timber grab, pallet fork, etc.

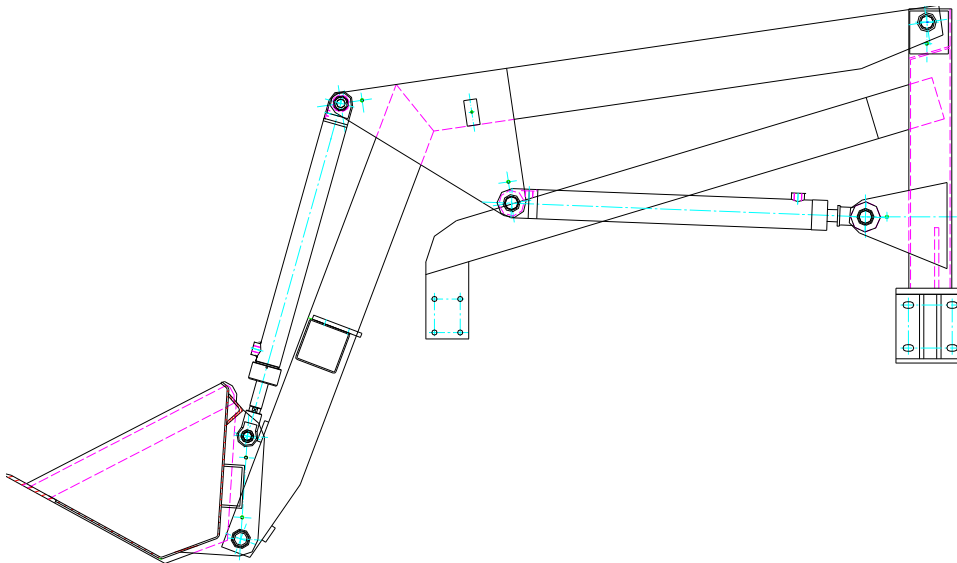

Fig.2-2 Common model (no quick-link)

The working device has couplings between buckets and lift arm, bucket and cylinder, lift arm and cylinder, lift arm and vertical column, vertical column and cylinder. Their mounting clearance is about 0.18~0.34mm. If the friction between linings and pins makes the clearance between them over 0.6~0.7mm, linings and pins should be replaced.

2.1.2 Model A (As shown in Fig.2-3)

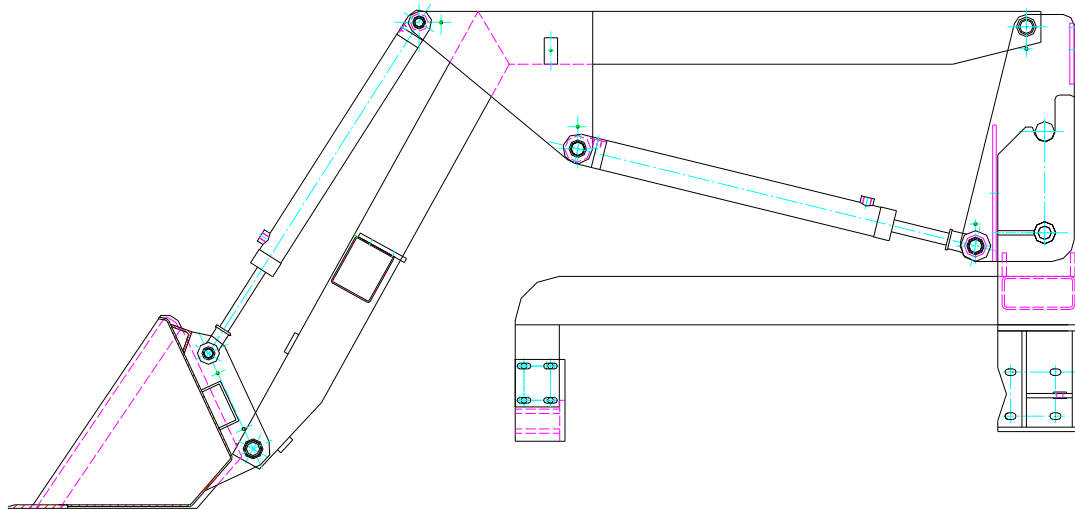

Fig.2-3 Model A (quick-link between lift arm and vertical column)

For model A (quick-link between lift arm and vertical column), the vertical column links to the tractor fixedly, the lift arm links to vertical column by quick-link. If necessary, take out the quick-link pins, put down the support leg, loosen the quick release coupling of the oil pipes, and then the lift arm will be separated from the vertical column, the frontloader will be separated off. The teeth are mounted on the edge blade of the bucket by bolts so that they may be replaced when worn out. The edge blade can also be cut off to replace when worn out. Various working devices can be replaced according to the work demand assembling bucket, timber grab, pallet fork, etc.

The working device has couplings between buckets and lift arm, bucket and cylinder, lift arm and cylinder, vertical column and cylinder, as well as the quick-link between the lift arm and vertical column. Their mounting clearance is about 0.18~0.34mm. If the friction between linings and pins makes the clearance between them over 0.6~0.7mm, linings and pins should be replaced.

2.1.3 Model B(As shown in Fig.2-4)

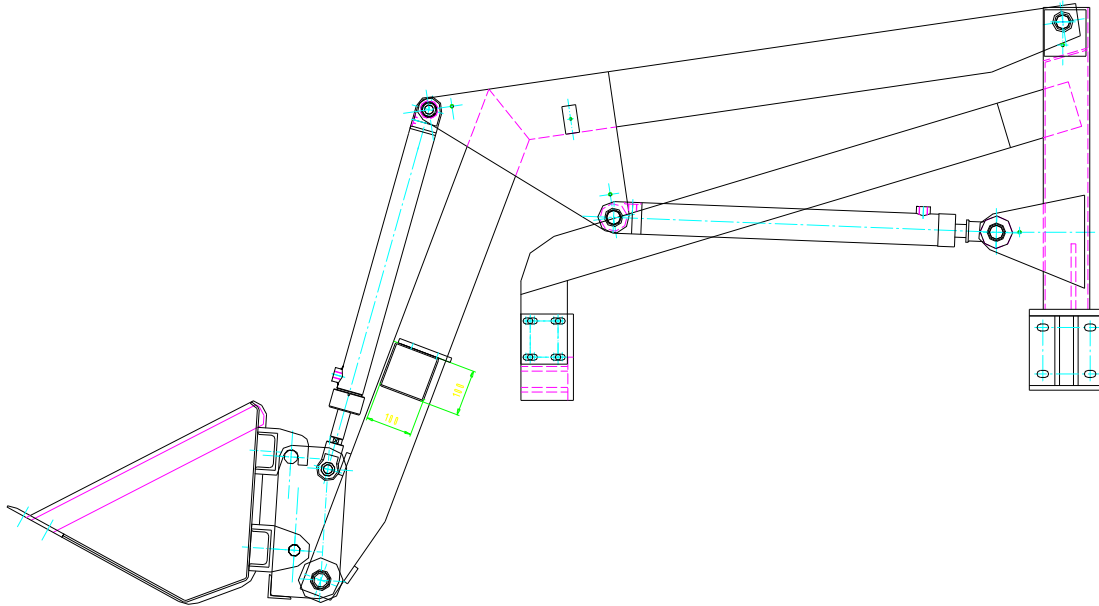

Fig.2-4 Model B (quick-link between lift arm and bucket)

For model B (quick-link between lift arm and bucket), the vertical column links to the tractor fixedly, the lift arm links to vertical column by fixed pins. If necessary, take out the fixed pins, put down the support leg, loosen the quick release coupling of the oil pipes, and then the lift arm will be separated from the vertical column. The lift arm and bucket link by quick-link pins. The bucket can be separated. So the lift arm can connect with other parts quickly, such as saucer fork, etc. The teeth are mounted on the edge blade of the bucket by bolts so that they may be replaced when worn out. The edge blade can also be cut off to replace when worn out. Various working devices can be replaced according to the work demand?assembling bucket, timber grab, pallet fork, etc.

The working device has couplings between lift arm and vertical column, bucket and cylinder, lift arm and cylinder, vertical column and cylinder, as well as the quick-link between the lift arm and bucket. Their mounting clearance is about 0.18~0.34mm. If the friction between linings and pins makes the clearance between them over 0.6~0.7mm, linings and pins should be replaced.

2.1.4 Model C (As shown in Fig.2-5)

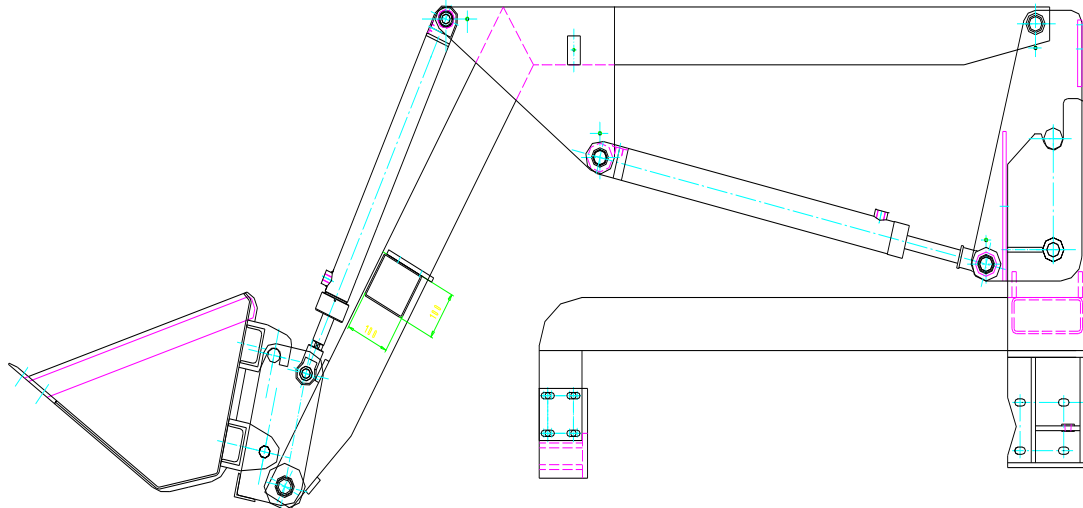

Fig.2-5 Model C (quick-link between lift arm and vertical column, lift arm and bucket)

For model C, the vertical column links to the tractor fixedly, the lift arm and vertical column, the lift arm and bucket are all by quick-link pins. If necessary, take out the quick-link pins, put down the support leg, loosen the quick release coupling of the oil pipes, and then the lift arm will be separated from the vertical column. The bucket can be separated from the lift arm. So the lift arm can connect with other parts quickly, such as saucer fork, etc. The teeth are mounted on the edge blade of the bucket by bolts so that they may be replaced when worn out. The edge blade can also be cut off to replace when worn out. Various working devices can be replaced according to the work demand?assembling bucket, timber grab, pallet fork, etc.

The working device has couplings between bucket and cylinder, lift arm and cylinder, vertical column and cylinder, as well as the quick-link between the lift arm and bucket, lift arms and vertical column. Their mounting clearance is about 0.18~0.34mm. If the friction between linings and pins makes the clearance between them over 0.6~0.7mm, linings and pins should be replaced.

2.1.5 Model D (As shown in Fig.2-6)

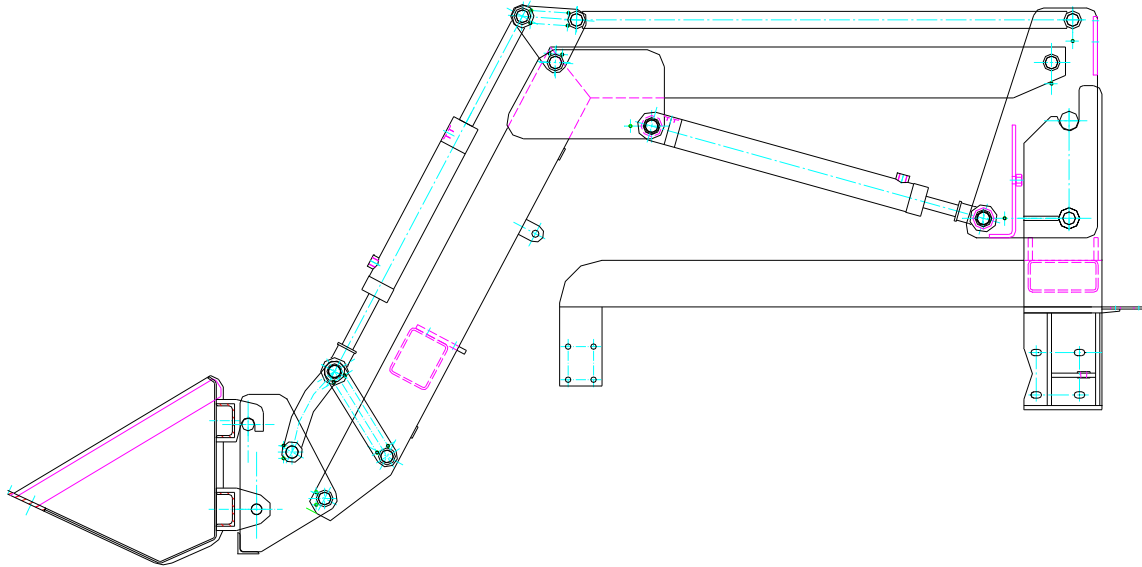

Fig.2-6 Model D (quick-link between lift arm and vertical column, lift arm and bucket (lift and drop parallel))

The lifting angle of the bucket is unchangeable when the lift arm lifts or drops. The characteristic is unique among all lift arms.

For model D, the vertical column links to the tractor fixedly, the lift arm and vertical column, the lift arm and bucket are all by quick-link pins. If necessary, take out the quick-link pins, put down the support leg, loosen the quick release coupling of the oil pipes, and then the lift arm will be separated from the vertical column. The bucket can be separated from the lift arm. So the lift arm can connect with other parts quickly, such as assembling bucket, saucer fork, etc. The teeth are mounted on the edge blade of the bucket by bolts so that they may be replaced when worn out. The edge blade can also be cut off to replace when worn out. Various working devices can be replaced according to the work demand?assembling bucket, timber grab, pallet fork, etc.

The working device has couplings between bucket and cylinder, lift arm and cylinder, vertical column and cylinder, as well as the quick-link between the lift arm and bucket, lift arm and vertical column. Their mounting clearance is about 0.18~0.34mm. If the friction between linings and pins makes the clearance between them over 0.6~0.7mm, linings and pins should be replaced.

2.2 Working device hydraulic system

Hydraulic system of working device is used to control the motion of lift arm and bucket to complete various working operation.

Working principle of hydraulic system:

The engine drives the oil pump which sucks oil from oil-tank. The pressure oil from oil

pump flows through distribution valve to lift cylinder or turn cylinder. By operating the control rod of distribution valve, the direction of oil flow is changed to make the bucket lift or turn. The system pressure is settled by the safety valve locating in the distribution valve. The bucket cannot turn and lift at the same time. When the bucket is turning, the hydraulic circuit to lift cylinder is cut off. Only when the turning hydraulic circuit stops working, can the lifting be done.

This system consists of geared pump, multi-way diverter valve, lift arm cylinder, bucket cylinder, oil-tank and flow line (Fig. 2-7).

Geared pump is showed in Fig. 2-8. One geared pump is used for working device hydraulic system and the tractor’s hydraulic lifting system together. Its highest pressure is 16Mpa. The structure of lift arm cylinder and bucket cylinder is showed in Fig. 2-9.

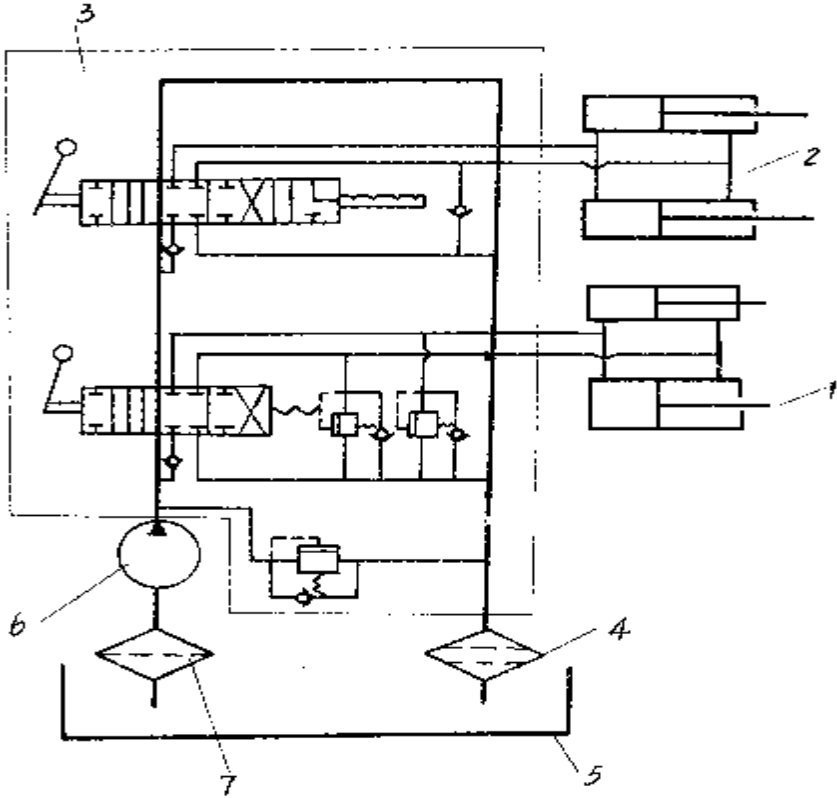

Fig 2-7 Sketch of hydraulic system working principle
1. Bucket cylinder 2.Lift arm cylinder 3.Distribution valve 4.Oil filter 5.Lifter
6.Oil pump 7.Rough oil filter

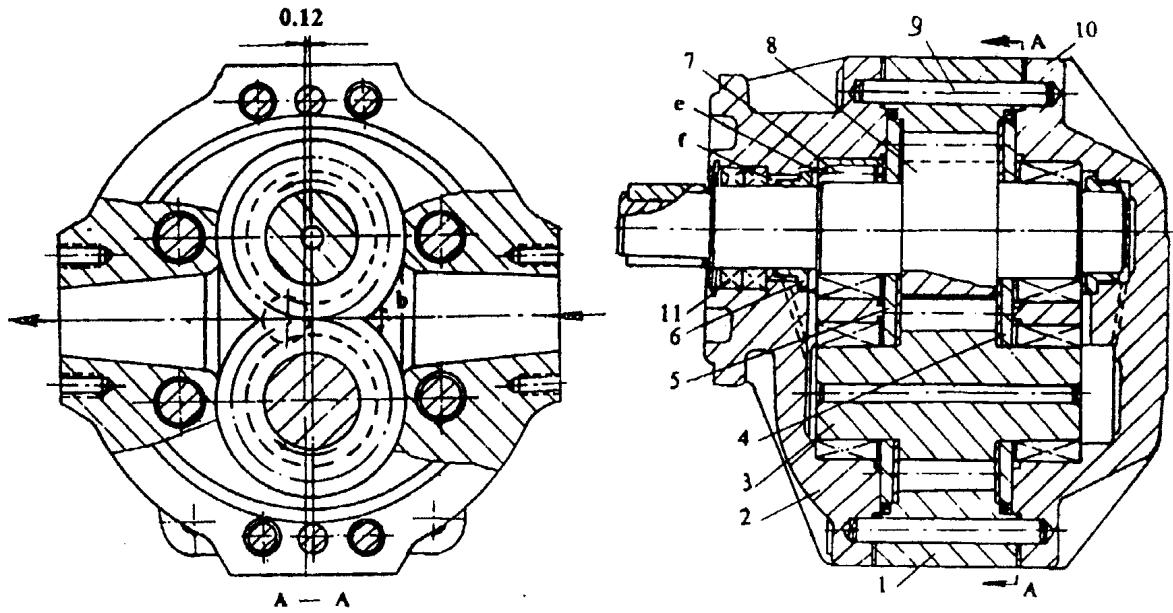

Fig 2-8 CBN-E314 Geared Pump

1. Pump body 2. Front cover 3. Driven gear 4, 5. Side plate 6. Seal ring 7. Rolling bearing 8. Driving gear
9. Set pin 10. Rear cover

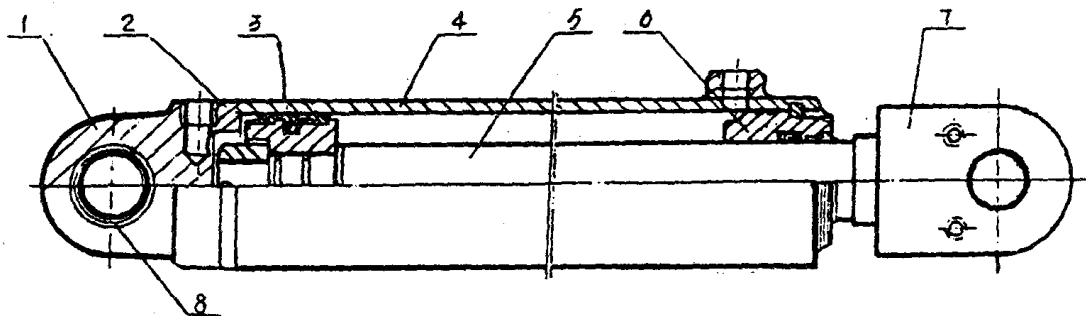

Fig.2-9 Hoisting Cylinder

1. Rear end 2. Piston 3. Bonded seal ring 4. Cylinder barrel 5. Piston rod 6. Guide bush
7. Rod end 8. Joint bearing

2.3 Disassembly and assembly of working device

2.3.1 Common model

- 1) Connect the underframe with vertical column by bolts and fix them to tractor.
- 2) Joint bucket, lift arm, support legs and cylinder with pins.
- 3) Put down the support legs, support the frontloader firmly, drive the tractor closely, joint the vertical column with lift arm by pins, and fix the pins with bolts.
- 4) Connect the oil lines with flexible hose, notice that high-pressure hoses can't be

distorted and be pulled too tight when installing.

5) During assembling, pour lubricant into every hinge, so as to make it rotate freely.

6) After assembly, make sure it is in neutral before start the engine, conjoin geared pump, operate multi-way diverter valve pole, lift the working device, check all oil lines' coupling, and ensure no leakage.

7) Operate multi-way diverter valve pole, make four cylinders and flow lines full of oil, then add hydraulic oil to the scale of the oil-tank, for fear that oil pump empty.

8) If the tractor is demanded to do other work, take out the pins connecting the vertical column and lift arm, put down the support legs, support the frontloader firmly, pull away the multi-way valve's quick coupling, separate the flexible hose from the underframe, and then the tractor can connect with other devices, such as pallet fork, etc.

2.3.2 Model A

1) Connect the underframe with vertical column by bolts and fix them to tractor.

2) Joint bucket, lift arm, support legs and cylinder with pins.

3) Put down the support legs, support the frontloader firmly, drive the tractor closely, connect the rear hitch of the lift arm with the vertical column by quick-change pins, and fix the pins with spring pins.

4) Connect the oil lines with flexible hose, notice that high-pressure hoses can't be distorted and be pulled too tight when installing.

5) During assembling, pour lubricant into every hinge, so as to make it rotate freely.

6) After assembly, make sure it is in neutral before start the engine, conjoin geared pump, operate multi-way diverter valve pole, lift the working device, check all lines coupling, and ensure no leakage.

7) Operate multi-way diverter valve pole, make four cylinders and flow lines full of oil, then add hydraulic oil to the scale of the oil-tank, for fear that oil pump empty.

8) If the tractor is demanded to do other work, take out the quick-change pins connecting the vertical column and lift arm, put down the support legs, support the frontloader firmly, pull away the multi-way valve's quick release coupling, separate the flexible hose from the underframe, and then the tractor can connect with other devices, such as pallet fork, etc.

2.3.3 Model B

1) Connect the underframe with vertical column by bolts and fix them to tractor.

2) Joint bucket, lift arm, support legs and cylinder with pins.

3) Put down the support legs, support the frontloader firmly, drive the tractor closely, put

the lift arm in the vertical column correctly and joint by pins, and then fix them with bolts.

4) Connect the oil lines with flexible hose, notice that high-pressure hoses can't be distorted and be pulled too tight when installing.

5) During assembling, pour lubricant into every hinge, so as to make it rotate freely.

6) After assembly, make sure it is in neutral before start the engine, conjoin geared pump, operate multi-way diverter valve pole, lift the working device, check all lines coupling, and ensure no leakage.

7) Operate multi-way diverter valve pole, make four cylinders and flow lines full of oil, then add hydraulic oil to the scale of the oil-tank, for fear that oil pump empty.

8) If the tractor is demanded to do other work, take out the pins connecting the bucket and lift arm, put down the support legs, support the frontloader firmly, pull away the multi-way valve's quick release coupling, separate the flexible hose from the underframe, and then the tractor can connect with other devices, such as pallet fork, etc.

2.3.4 Model C

Same as Model A

2.3.5 Model D

Same as Model A

2.4 Driving and operation

The driver should be firstly acquainted with the specification, structure, operation methods, technical maintenance and service of the frontloader in order to guarantee safe driving and operation.

2.4.1 Notes for operation and itinerant maintenance

2.4.1.1 Notes for operation

1) The driver, with driving license at least for large tractor, should read thoroughly this manual, and be trained with traffic regulations, structural principle of frontloader and practical operation before driving and work. There should be only one person in the cab.

2) Use oils of required brand that meet the quality standards.

3) Maintain the machine periodically according to requirement.

4) After starting, make the engine run idle for 5-10min till the reading of meter is normal, then loosen the hand brake knob and begin driving.

5) Temperature of engine coolant should not over 100°C during operation, and that of converter should not over 120 °C, otherwise stop operation immediately for cooling.

2.4.1.2 Itinerant check

Precede the followings before work every day.

- 1) Check the conditions of damage, wear or looseness of working device, hydraulic cylinders, linkage rods as well as hoses, etc., and repair them in time.
- 2) Remove dirt and dusts around engine, battery and radiator.
- 3) Check whether there is oil or water leakage in engine, and repair the abnormal parts.
- 4) Inspect whether there is leakage in gear box case, driving axles, hydraulic tanks, flexible hoses as well as connections and repair them in time.
- 5) Check whether there is leakage in brake hydraulic circuit.
- 6) Check whether the tyres are damaged or worn, or the assembling bolts are loose.
- 7) Check whether the handrails and pedal are damaged, or bolts are loose.
- 8) Check whether the meters and electrical parts are damaged, or the bolts and couplings are loose.

2.4.2 Checks and maintenance before and after work

2.4.2.1 Checks before work:

- 1) Whether the fuel in tank is sufficient.
- 2) Whether the coolant in engine radiator is enough.
- 3) Whether the lubricant in oil pan of the engine is up to required level.
- 4) Whether the working hydraulic oil and brake oil are sufficient.
- 5) Whether the tyre pressure is normal.
- 6) Whether the bolts for rims and transmission shafts are loose.
- 7) Whether the shift lever and high-low speed control lever are in idle Gear, and the working device control lever is in neutral positions.

2.4.2.2. Checks after engine starting:

- 1) Whether readings of all meters are normal.
- 2) Whether there is leakage in every system.
- 3) Whether each switch, lamp, meter and horn is normal.
- 4) Whether there is abnormal noise in engine or transmission system.
- 5) Whether each handle is flexible and reliable.
- 6) Whether the steering wheel is loose.
- 7) Whether the brake is reliable.
- 8) Whether the operations of working device is normal.

2.4.2.3. Maintenance after work

- 1) Check the remains of fuel in diesel tank.
- 2) Check whether the oil level in oil pan is normal.
- 3) Check whether the transmission system and each driving part overheat.
- 4) Check whether the bolts of rims and transmission shafts as well as the set plate of each pin are loose.
- 5) Check whether the outline and pressure of tyres are normal.
- 6) Fill lubricant to each rotating part.
- 7) Drain the coolant out of engine radiator and engine during winter. (except with antifreeze) .

2.4.3 Driving without load

2.4.3.1 Start

- 1) Locate the shift lever on idle Gear.
- 2) Let the hand brake on “brake” position.
- 3) Turn the electrical switch on, insert the key in the electrical switch and turn to the right position.
- 4) Push the start button and add oil slightly, it can be started. It should be noticed when starting that the time of starting must be less than 10 seconds. If it needs to start again, it should have 30-40 seconds interval. If it can't be started three times continuously, the reason should be inspected before start again.

2.4.3.2 Driving

- 1) After start, the engine must run 5 min. without load, and the reading of meters should be normal.
- 2) Draw back the bucket and lift it to transport position (The arm pivot point is 400mm high from the ground.)
- 3) Loosen the hand brake.
- 4) Step down the clutch pedal, locate the shift lever and the high-low speed control lever on right position, then loosen the clutch pedal, step down the accelerator pedal, the frontloader can drive.

2.4.3.3 Stop

Before stop the frontloader, locate the gear lever on idle Gear, let the engine run 2-3 min. at lower speed, and then pull up the flameout line, press the line button down later. Thereafter pull up the hand brake, take out the electrical switch key. The chief switch of electric must be cut off if stopping for a long time.

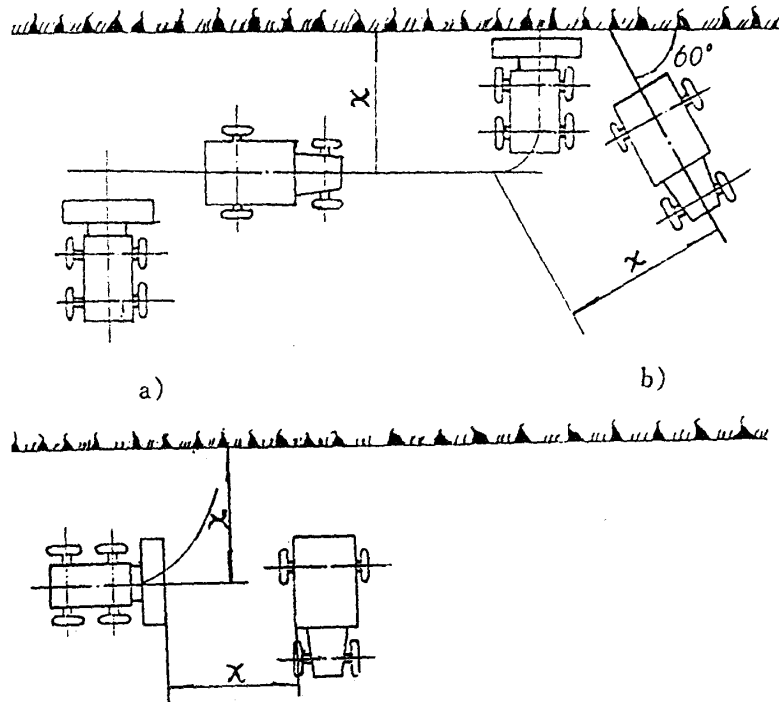

Fig.2-10 Working Patterns

2.4.4 Operation

The working patterns can be selected according to the loading materials and working sites. Followings are the introductions of working patterns and notices for operation, as the reference to users.

2.4.4.1 Refers to Fig.2-10 for working patterns.

2.4.4.2 Preparations before work.

Clear and level the working site firstly.

2.4.4.3 Shoveling operation.

1) Shift the gear lever to Gear II; drive the frontloader to material pile, leveling the bucket during the traveling.

2) Shift to Gear I when the frontloader is near to pile, shovel the edge blade of bucket into the pile, accelerate the speed and roll back the bucket to limit position gradually.

3) Lift the bucket to carrying position, push the control lever to neutral position, gear to reverse II speed and retract the frontloader from pile.

2.4.4.4 Transporting

The frontloader has higher efficiency within 100m when transfer materials. The transport speed should change according to the road surface. Never raise the lift arm with load when transporting, especially on uneven road.

2.4.4.5 Dumping

When the frontloader is near to dumping spot, raise the bucket to necessary height, push forward the bucket's control lever to tilt the bucket forward for dumping. When loading to a truck, lift the bucket to dumping height at a certain distance from the truck, and drive the frontloader slowly to carriage for dumping. The operation should be as gentle as possible in order to reduce the impact of material upon truck. If the material is sticky to bucket wall, operate the lever back and forth to shake the bucket and dump down the materials completely.

2.4.4.6 Other operation

The frontloader can also be used for earth shoving, leveling, digging, pulling, hoisting and etc.

3 Accessories

3.1 Sorts and function

The frontloader can outfit six kinds of working devices, involving the universal bucket, assembled bucket, bars-casing bucket, pallet fork and timber grab. Users can choose the aided parts based on demands.

3.1.1 Assembled bucket (As shown in Fig. 3-1)

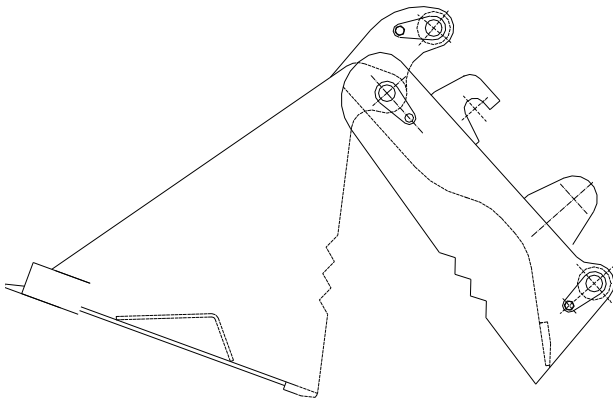

Fig.3-1 Sketch of assembled bucket

Function of assembled bucket:

- 1) Use as the basic bucket.
- 2) Use as bulldozer.
- 3) Loading goods.
- 4) Backfill and leveling ground.

3.1.2 Bars-casing bucket (As shown in Fig. 3-2)

Function of bars-casing bucket:

There is a bars-casing on the bucket for fear that the material fall out of it.

3.1.3 Pallet fork (As shown in Fig. 3-3)

Function of pallet fork:

Move the material parallel for short or long distance.

3.1.4 Timber grab (As shown in Fig. 3-4)

Function of timber grab:

Grasp the wood and transport for short or long distance or load on a truck, it is convenient and economic.

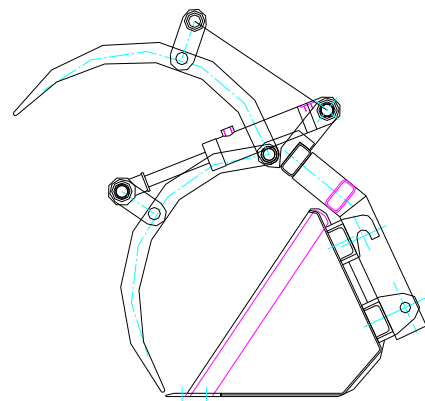

Fig.3-2 Sketch of bars-casing bucket

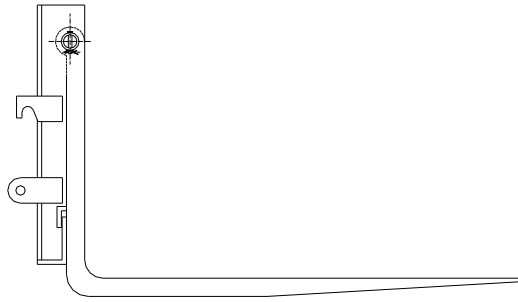

Fig.3-3 Sketch of pallet fork

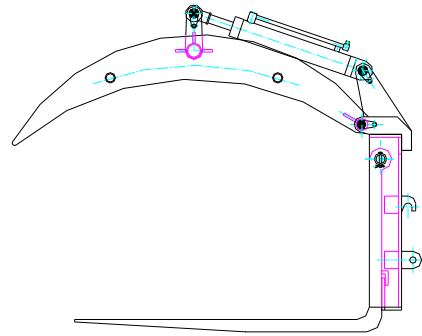

Fig.3-4 Sketch of timber grab

3.2 Disassembly and assembly of accessories

The methods are the same as those of bucket. The accessories can disassemble and assemble referring to chapter II.

4 Technical maintenance and common trouble and troubleshooting

4.1 Technical maintenance

In order to guarantee the continuous full-load operation of the frontloader in awful circumstances and prevent the wear in early period, periodical maintenance is necessary for keeping the frontloader in ideal technical state constantly.

4.1.1 After assembled, fill hydraulic oil into working oil-tank, fill lubricant to every lubricating point, put it into running-in test, let cylinders run for 20 hours, and then replace hydraulic oil.

4.1.2 The maintenance of hydraulic loading device should be taken after the tractor stops completely and the hydraulic system must be no loads. The maintenance should obey the follows:

- 1) Check the tightening between hydraulically loading device and tractor.
- 2) Check the fuel level in oil-tank and whether there is leakage in hydraulic system.
- 3) After work, the bucket should be put on ground, so as to relieve load on the front wheels and prolong their service life.

4.1.3 If don't use it for a long time, put it into a dry room, for fear it be solarized and be showered and rust.

4.2 Common trouble and troubleshooting

Here are the common troubles and trouble-shootings of the working device and hydraulic system.

4.2.1 The lift arm and bucket move slowly or keep still.

| | |
|--|---|
| 1. Seals of cylinders are damaged | 1. Replace with new seals |
| 2. Pipeline system leaks | 2. Check and repair |
| 3. Inner of working pump leaks seriously | 3. Repair or replace the pump |
| 4. Relief valve is adjusted improperly and system pressure is on the low side. | 4. Adjust the system pressure to required value |
| 5. There is air in the suction pipe of working pump or the oil filter blocked. | 5. Clean the filter or replace the oil suction pipe |
| 6. The mounting clearance of pilot-controlled valve is too large. | 6. Repair or replace the valve |

4.2.2 The pump is empty sucked or there are foams in oil

| | |
|--|---|
| <ol style="list-style-type: none"> 1. Oil level is overflow. 2. Filter is blocked 3. Oil pump is damaged 4. Oil suction pipe leaks or seals in pump are damaged 5. Oil is Bad or deteriorated | <ol style="list-style-type: none"> 1. Fill oil to required level 2. Clean the filter 3. Repair or replace the pump 4. Repair or replace the damaged parts 5. Replace with required oil |
|--|---|

4.2.3 Oil temperature is over high

| | |
|---|--|
| <ol style="list-style-type: none"> 1. Working time is over long with full load 2. System pressure is over high 3. Oil level is over low 4. Oil pumps is damaged 5. Flow lines is blocked | <ol style="list-style-type: none"> 1. Stop for cooling 2. Adjust to required pressure 3. Fill oil to required level 4. Repair or replace the pump 5. Repair, clean or replace |
|---|--|