

TRIDENT

**TRACTOR 60HP 4WD with FEL & 4in1 Bucket
with 12 Speed Synchronmesh Gearbox**

Nicola's Machinery - Small Acreage Specialist

- Your one stop farming solution



NICOLA'S MACHINERY

3 YEARS WARRANTY

SOUTH AUSTRALIA BASED AUSTRALIA WIDE DELIVERY



Trident Tractor Model 604 60hp 4wd

-Luxury and comfortable G3 model

G3 model of Trident 60hp tractor is a new product which is designed and optimized by European Technical Team.

With a brand new cab structure, air conditioner + sunroof window, first-class tightness + manipulation space, interior trim, luxury adjustable seat, adjustable steering wheel, brand new hood assembly, the whole cab looks more fashionable and energetic, with its safety improved.



We use TRELLEBO radial tires with front/ rear size of 280/70R20,380/85R24 on Trident 60hp tractor to increase performance, grip & stability. You can also choose from paddy field, grassland and engineering tires according to the working conditions.



Handle is properly positioned and easily controlled, allowing safer and more comfortable operation

Optimized ergonomic design, reasonable control distribution and color division, as well as right-side manipulation; suspended accelerator and clutch pedal; manual accelerator and shuttle shift mechanism below the steering wheel; and steering gear can be adjusted back and forth.



The air inlet and outlet pipes are concealed behind the A-pillar of cab, providing you with better vision.

The larger oil tank will provide you with a longer operation time.





Standard four-cylinder engine

Engine

The new 4-cylinder in-line diesel engine has a power range of 35-70hp; the ultralow fuel consumption (less than 245g/kwh) and extra-large torque output (155-245n.m) will make your work more efficient and energy-saving. In addition, it has passed the EPA and Euro III Emission Standards certification.

High torque reserve

The torque reserve of engine is up to 25%, which will can provide you with enough torque in the traction operation; help you to overcome the resistance produced in the tillage so that you do not need to frequently shift gears; and make your work more efficient.

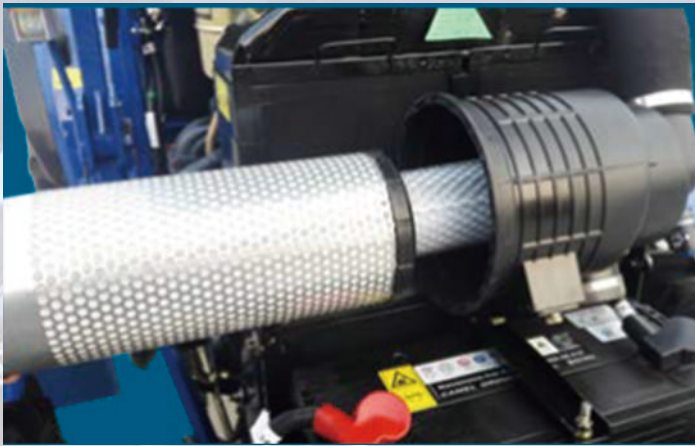

Enhanced cylinder

The cylinder is enhanced and connected with the gearbox, when they are to bear the weight of the complete tractor, the high-strength and high-rigidity cylinder will help you to calmly handle the heavy operations or bad ground working conditions.

High fuel efficiency

Direct injection technology is adopted in cylinder to realize full combustion. The engine does more work with unit fuel consumption.



Battery

Being maintenance-free, no electrolyte is required for the storage battery, which guarantees its high reliability and long service life, and saves the maintenance costs.

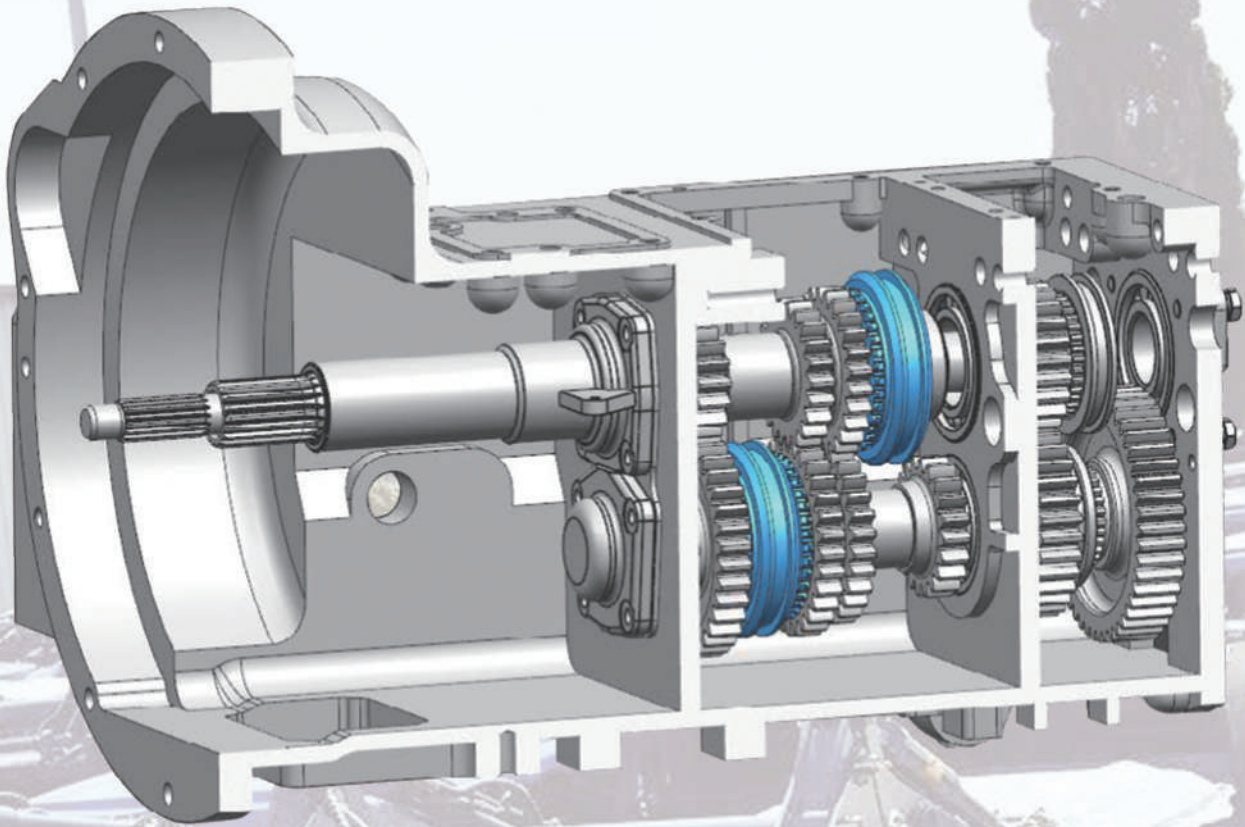

Smooth and convenient gearbox

Shuttle shift gear lever C is located on the right side of floor. If you push the gear lever C forward from the neutral position, forward gear is reached; and if you push it backward, reverse gear is reached.

12+12 gearbox

12+12 gearbox consists of 3 gear levers. The main gear lever A can reach 4 gears (1, 2, 3 and 4), auxiliary gear lever B can reach 2 forward speed zones (1, 2 and 3), and shuttle shift gear lever C can reach the forward and reverse gears.

Proper speed distribution

Proper working speed selection can not only deliver maximum productivity and economic efficiency, but also extend the service life of tractors. Tractors shall not always be operated at overload, so that engine can have a certain power reserve. Field working speed of tractors shall ensure that engine works at around 80% of its rated load. To save fuel, you can throttle down at gear H1 in case of light load operation and low working speed.





Front axle with good manipulating performance and high reliability

The middle double action oil cylinder is more flexible in manipulation, and the overall ground clearance is larger.

The middle double action oil cylinder is provided with the oil inlet and outlet functions, which shortens the lever between the cylinders, and makes the structure simpler. One cylinder controls the action of levers on both sides, and the hydraulic steering makes the manipulation more flexible. With larger ground clearance and better accessibility, the user can drive it without trouble in complex landforms.

1. Step-less adjustable limit bolt

The steering angle is limited, which not only ensures the steering safety, but also provides more adjustment options for users on the steering radius.

2. Regulating lever

The regulating lever can be shorter, which makes the manipulation more accurate and helps to obtain consistent, reliable and strong steering performance in case of uneven landform.

3. Excellent tightness

The tractor design is optimized, and high-quality seals are provided to achieve high waterproofness.

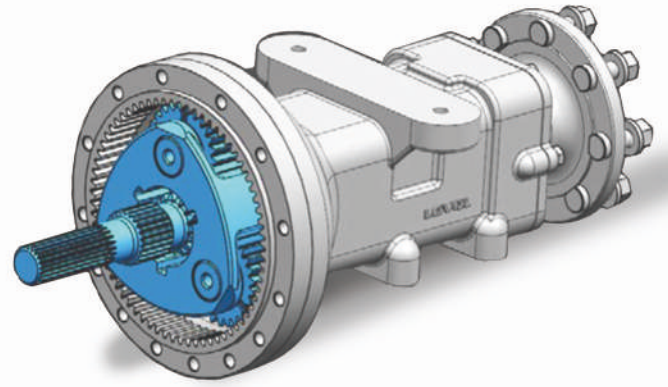

Rear axle with high reliability and large driving force

Planetary reduction mechanism with high reliability.

This rear axle with planetary reduction mechanism, differential mechanism and wet brake is used on the rear drive axle of M Series 40-75hp products, which possesses high durability, stability and reliability and is almost free of maintenance under normal conditions. In addition, the operation is comfortable, safe and reliable.

Differential lock provides the driving force that is more stable.

The differential lock pedal is located on the floor at the right side of cab so that the driver can hitch the differential lock when releasing the clutch. If the driving forces on both sides of the rear axle are uniform, the differential lock will be automatically released.

Multi-functional Operation Capacity



Field operations

The driver can choose the optimum PTO speed according to the actual ground conditions, which not only improves the working efficiency, but also reduces the fuel consumption. Low speed is applicable to heavy PTO operations like rotary tillage, especially in the case that soil is compact. You can switch to the high PTO speed when the soil is soft in such light PTO operations as the secondary rotary tillage or mowing to maximize the working efficiency and complete the operations faster.



Construction operations

High-performance control valve
High-performance hydraulic control valve of European brand is applied, which is stable in performance, reliable in quality, and low in maintenance costs. You can choose the third loop to provide hydraulic control for the multi-functional equipment.



Transportation operation

The standard Tractor Model 604 tractor is equipped with 25mm-thick draw bar (enhanced 36mm-thick draw bar optional) made of high-quality steel produced with heat treatment process, featuring high strength and toughness. When small-sized trailers or pesticide vehicles are dragged, enhanced draw bars are capable to bear stronger traction and torque force.

NOTES



Engine:

Engine Model:	XINCHAI A498BT
Engine Displacement:	4.2L
Engine Type:	Diesel
Engine Gross Power:	44/2,400 KW/RPM
PTO Power:	34.4KW
No. of Cylinders:	4
Total Displacement:	3.17 cc
Alternator:	14V /0.75KW
Fuel Tank Capacity:	65L (with auxiliary fuel tank)
Cooling:	Coolant Cooled

Transmission

Transmission:	Synchromesh Shuttle shift 12+12
Clutch:	11 inch Dual Functional Clutch with Metal Ceramic Friction Plate
Drive:	Rear Wheel Drive with select- able 2WD / 4WD and Differ- ential Lock
Differential:	Closed, 2 Planetary Reduction Bevel Gears
Differential Lock:	Tooth Inlaid Type

Measurements & Weights Tractor

Tractor Weight:	3,355 kg
Wheelbase:	2,040mm
Overall Dimens:	4,980 x 1,800 x 2,600 mm
Turning Circle:	3.8±0.3 m
Min. ground clearance:	360 mm

Steering, Wheels & Brakes Suspension:

Suspension:	Front Beam Rocking Axle
Steering:	Hydraulic Steering with Inde- pendent Pump
Brakes:	Oil immersed breaking system
Radial Tyre size :	280/70R20, 380/85R24

Miscellaneous

Colour:	Blue
PTO Speed:	540/760 rpm
Hydraulic Remotes:	Multi-valve 2 way remote hy- draulics
Hydraulic Output Flow:	65L/MIN
3-Point Linkage:	Category 2, Hydraulic, 11.5Kn Lifting Capacity
Starting:	Electric
Electrical:	12V
Lift Control Type:	Force control & Position con- trol
Standard Extras:	TRELLEBORG radial tyre with double tyre weights for any rough terrain; Deluxe aircon cab cooling and heat- ing; 900mm wide & flat oper- ator deck for comfortable driving; Zinc plated 3 point linkage adjustments; Heavy chassis designed for front end loader work.

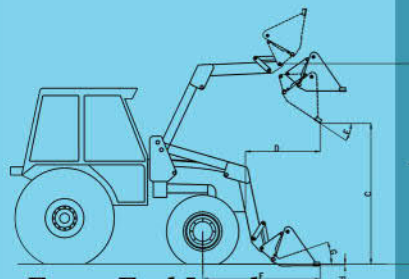

Front End Loader

Model	TZ06D
Max.lift height (mm) (A)	3,000
Max.dump height (mm) (C)	2,300
Dump distance (mm) (D)	1.140
Dump angle (°) (E)	45°
Distance of bucket to the centre - of front-wheel (mm) (F)	2,320
Rollback angle on ground (°)(G)	34
Max. digging depth (mm) (H)	140
Bucket width (mm)	1,652
Bucket capacity (m3)	0.43
Rated lift capacity (kg)	650

*Specifications may change without notice. Stock is subject to availability. All information is correct at time of printing.

Nicola's Machinery Pty Ltd

Phone Number: 08 7228 6817
Service & Warranty : 0431 708 169
Address: 40 Donegal Road Lonsdale, SA 5160

Email: terry@nicolasmachinery.com.au
Website: www.nicolasmachinery.com.au
Facebook: www.facebook.com/www.nicolasmachinery.com.au/