



119 Van Order Drive, Kingston, ON K7M 1B9 🏠 Fax (613) 546-9375 🏠 Phone (613) 546-5591 [www.kfhc.ca](http://www.kfhc.ca)

# PROJECT MANUAL

## THK PT 19-03

LOCATION: 375 Patrick Street  
Various Units  
Kingston, ON

WORK: Front Step Replacement

PRE-BID MEETING: Thursday, March 21, 2019  
11:00 a.m. Local Time  
375 Patrick Street, unit B1  
Kingston, ON

CLOSING DATE: Thursday, March 28, 2019  
11:00:00 a.m. Local Time  
119 Van Order Drive  
Kingston, ON



Contractor Name and Address:

<b>Closing Date</b> March 28, 2019
<b>Time</b> 11:00:00 a.m. Local Time
<b>Description of Work</b> Front Step Replacement
<b>Address</b> 375 Patrick Street Kingston, ON
<b>Tender No.</b> THK PT 19-03

**PUBLIC TENDER BID ENVELOPE**

**DO NOT OPEN**

Kingston & Frontenac Housing Corporation  
119 Van Order Drive  
KINGSTON, ON K7M 1B9

PLEASE PRINT THIS PAGE AND ATTACH IT TO YOUR BID SUBMISSION ENVELOPE



<b>DOCUMENT</b>	<b>Page</b>
00 00 03 Specification Index	6
00 03 00 Bid Form	7
00 04 00 Form of Bid Bond	13
00 06 00 Form of Performance Bond	15
00 10 00 Instruction to Bidders	25
00 72 13 General Conditions	34
01 10 01 General Requirements	42
01 78 36 Payments, Warranties, and Bonding	51
07 77 00 Construction Specifications	53
Appendix A – Work Reference	57
Appendix B – List of Construction Drawings	59
Drawings:	
S1 – Decks at Main Entrance	61
S2 – Decks at Main and Rear Entrance	63
A-1 – Site Plan	65

## **NOTE**

Bidders must ensure that they receive all the contents listed above. Any omissions must be drawn to the attention of the Housing Office at least five (5) days prior to bid closing.

---

**SPECIFICATIONS INDEX**

**No. of Pages**

00 03 00	Bid Form	5
00 04 00	Form of Bid Bond	1
00 06 00	Form of Performance Bond	10
00 10 00	Instruction to Bidders	9
00 72 13	General Conditions	8
01 10 01	General Requirements	9
01 78 36	Payments, Warranties, & Bonding	2
07 77 00	Construction Specifications	3
	Appendix A – Work Reference	1
	Appendix B – List of Construction Drawings	1
	Drawings:	
	S1 – Decks at Main Entrance	1
	S2 – Decks at Main and Rear Entrance	1
	A-1 – Site Plan	1

Scott VanderSchoor, acting on behalf of Town Homes Kingston  
Kingston & Frontenac Housing Corporation  
119 Van Order Drive  
Kingston, Ontario K7M 1B9

Re: **THK PT 19-03**  
**Front Steps Replacement**  
**375 Patrick Street**  
**Kingston, Ontario**

**1.0 CONTRACT PRICE**

The Contractor hereby offers to complete the Work specified in the contract for the following prices for:

Item No.	Description	Est Qty.	Unit	Unit Price	Total Item Cost
1	Removal and replacement of Deck Style # 1	12	Each		
2	Removal and replacement of Deck Style # 2	1	Each		
3	Removal and replacement of Deck Style # 3	6	Each		

The Kingston Municipal Non-Profit Housing Corporation (Town Homes Kingston) has the right to eliminate any or all sections of the project (in the itemized bid form) at any time after Tender Closing without penalty.

The Tenderer hereby offers to complete the work specified for Tender THK PT-03 for the following prices:

<b>Sub-Total</b>	<b>\$</b>
<b>HST</b>	<b>\$</b>
<b>TOTAL COST</b>	<b>\$</b>

.1 I/We \_\_\_\_\_  
(Company Name)  
having carefully examined the Bid Documents and visited the Project Site, and having examined and complied with Section 00 10 00 – Instruction to Bidders, hereby offer to enter into a Contract to perform the work required in the Bid Documents and Construction Specifications for the **STIPULATED PRICE** of

\_\_\_\_\_ Dollars (\$ \_\_\_\_\_) including payment of all applicable federal, provincial and municipal taxes.

This Bid is firm, irrevocable and open to acceptance by the Owner for sixty (60) days from the date of Bid closing.

.2 **The following amount of HST has been included in the above STIPULATED PRICE**

**\$ \_\_\_\_\_ HST REGISTRATION NO. \_\_\_\_\_.**

.3 I/We agree to comply in all respects with the requirements set out in the Bid Documents including **ADDENDA No. \_\_\_\_\_ to No. \_\_\_\_\_** inclusive as issued as supplements thereto. (If no addenda have been received, indicate 'NIL' in the spaces provided).

.4 I/We agree to commence this work immediately upon being notified in writing to do so by the Housing Corporation and that work will be done on a continuous basis.

.5 I/We expressly warrant that the prices contained in my/our bid, whether as unit prices or lump sums are quoted in utmost good faith on my/our part without any collusive arrangement or agreement with any other person or partnership or corporation and that I/we are not party or privy to any deceit tending to mislead the Owner into accepting my/our bid as a truly competitive offer.

.6 I/We agree to complete all work required, acceptable to the Owner.

.7 I/We enclose a bid bond, certified cheque, bank draft or irrevocable letter of credit in the amount of **\$3,000.00** payable to **Town Homes Kingston** and valid for sixty (60) days from the date of bid closing.

.4 **Tax Compliance Declaration**

I hereby certify that \_\_\_\_\_ at the time  
(Company Name)

of submitting this bid, is in compliance with all tax statutes administered by the Ministry of Finance for Ontario and that in particular, all returns required to be filed under all provincial tax statutes have been filed and all taxes due and



payable under those statutes have been paid or satisfactory arrangements for their payments have been made and maintained.

**2.0 SUBCONTRACTORS**

- .1 We submit a complete list of subcontractors we propose to use on this Contract and the Sections of the Work to be done by them.
- .2 We reserve the right to substitute another subcontractor for the same work in the event that a subcontractor should withdraw his bid, or become bankrupt. All subcontractor substitutions are subject to the Owner's approval.
- .3 Any such substitution, in order to be considered for approval by the Owners and/or Consultant, is contingent on the submission of conclusive evidence of withdrawal, bankruptcy or unsatisfactory performance.
- .4 The Contractor is responsible for all costs incurred as a result of substituting one subcontractor for another.
- .5 **Tenders may not be considered unless the names of all subcontractors are listed in space provided.**

SECTION	TITLE	NAME OF SUBCONTRACTOR

**3.0 AGREEMENT TO BOND**

- 3.1 Attached is our agreement to provide performance bonds as requested in Bid Documents.
- 3.2 We agree to furnish Bonds in accordance with "Section 00 10 00 – Instructions to Bidders" and the General Conditions of this contract within fourteen (14) days of Contract execution.

#### 4.0 ACCEPTANCE

- 4.1 This Bid is irrevocably open to acceptance for a period of **sixty (60) days** from the date of bid closing and is promised in consideration of the amount of **\$3,000.00**. Failure to enter into a contract after Owner's acceptance of this bid shall result in forfeiture of the Bid Security.
- 4.2 We agree to enter into a contract with the Owners within five (5) days of written notification of acceptance of this Bid.
- 4.3 We understand and agree that this bid may be adjusted in accordance with any or all of the separate or additional prices submitted herewith.
- 4.4 We understand that the submission of this bid implies acceptance of the existing conditions at the site.
- 4.5 We understand that the lowest or any tender will not be necessarily be accepted and that selected items may be deleted from the Project as represented in the Bid Form.
- 4.6 We understand that the Owner reserves the right to waive minor defects or irregularities in the bid submission.
- 4.7 We understand that the Owner may withhold total and partial payment to cover third party liability claims as outlined in Tender Documents.
- 4.8 We agree to complete The Work by **June 21, 2019** as outlined in these specifications.
- 4.9 We understand that Contract time is of the essence and that any improvements to the schedule submitted with our bid will be considered prior to the award of the Contract. We therefore submit the following improvement to the completion date indicated in the tender package for consideration in evaluating our **Bid THK PT 19-03**.

**5.0 BIDDER'S SIGNATURE AND COMPANY SEAL**

SIGNED AND SEALED\* this \_\_\_\_\_ day of \_\_\_\_\_, \_\_\_\_\_.

**Print full name**

Contractor: \_\_\_\_\_ Signing Officer: \_\_\_\_\_

Address: \_\_\_\_\_ WSIB Account Number: \_\_\_\_\_

City: \_\_\_\_\_ Postal Code: \_\_\_\_\_

Telephone No.: \_\_\_\_\_ Fax No.: \_\_\_\_\_

Cell No.: \_\_\_\_\_

Signature: \_\_\_\_\_

Printed Signature: \_\_\_\_\_

Email Address: \_\_\_\_\_

**NOTE: BIDDERS ARE ADVISED THAT FAILURE TO COMPLETE THIS FORM WILL CAUSE DISQUALIFICATION.**

\* Affix Corporate Seal (if applicable).

**END OF SECTION**



Bond No. \_\_\_\_\_ Project No. \_\_\_\_\_

Amount \$ \_\_\_\_\_

**Know All Men By These Presents**, that \_\_\_\_\_

As Principal, hereinafter called the Principal, and \_\_\_\_\_

as Surety, hereinafter called the Surety, are held and firmly bound unto **Town Homes Kingston** as Obligee, in the amount of \_\_\_\_\_

\_\_\_\_\_ Dollars (\$ \_\_\_\_\_)  
lawful money of Canada, for the payment of which sum, well and truly to be made, the Principal and the Surety bind themselves, their heirs, executors, administrators, successors and assigns, jointly and severally, firmly by these presents.

Whereas, the Principal has submitted a written proposal, (or tender) to the Obligee dated the \_\_\_\_\_ day of \_\_\_\_\_, \_\_\_\_\_, for \_\_\_\_\_

Now Therefore The Condition Of This Obligation in such that if the aforesaid Principal shall have the tender accepted within sixty (60) days from the closing date of the Call for Tenders and the said Principal will, within such reasonable time as may be allowed after notice of such acceptance, enter into a formal contract and give a good and sufficient bond to secure the performance of the terms and conditions of the contract, then this obligation shall be null and void; otherwise the Principal and Surety will pay unto the Obligee the difference in money between the amount of the bid of the said Principal and amount for which the Obligee legally contracts with another party to perform the work if the latter amount be in excess of the former.

The Surety shall not be liable for a greater sum than the specified penalty of this Bond. Any suit under this Bond must be instituted before the expiration of six months from the date of this Bond.

The Testimony Whereof, the Principal has hereunto set its had and affixed its seal, and the Surety has caused these presents to be sealed with its corporate seal duly attested by the signatures of its duly authorized officers, this \_\_\_\_\_ day of \_\_\_\_\_, A.D. \_\_\_\_\_.

**Signed, Sealed and Delivered**

in the Presence of:

\_\_\_\_\_  
Principal

\_\_\_\_\_  
Surety

**END OF SECTION**



No. ....(the “**Bond**”) Bond Amount \$ .....

.....  
(name of the contractor\*)

as a principal, hereinafter [collectively] called the “**Contractor**”, and

.....  
(name of the surety company\*\*)

.....  
a corporation created and existing under the laws of .....  
(place of incorporation)

as a surety, and duly authorized to transact the business of Suretyship in the Province of Ontario and hereinafter called the “**Surety**”, are held and firmly bound unto Town Homes Kingston as obligee, hereinafter called the “**Owner**”, in the amount of

\$ .....  
(Bond Amount in figures)

hereinafter called the “**Bond Amount**”, for the payment of which sum the Contractor and the Surety bind themselves, their heirs, executors, administrators, successors and assigns, jointly and severally in accordance with the provisions of this Bond (the “**Obligation**”).

WHEREAS the Contractor has entered into a written contract with the Owner dated the ..... day of ..... in the year ..... for .....  
(name of month) (title or description of the contract)

(the “**Original Contract**”) and, for the purpose of specifying the conditions of the Obligation, this contract together with amendments made in accordance with its terms are by reference made part hereof and are hereinafter referred to collectively as the “**Contract**”;

NOW THEREFORE the condition of this Obligation is such that if the Contractor shall promptly and faithfully perform the Contract then this Obligation shall be null and void; otherwise it shall remain in full force and effect, subject to the following terms and conditions:

**1. WRITTEN NOTICE**

- .1 The Owner may make a written demand on the Surety in accordance with this Bond, by giving notice to the Surety substantially in the form Schedule A (the “**Notice**”), shared when necessary. Except for a Pre-Notice Meeting in accordance with Section 2.1, the Surety shall have no obligation under this Bond until it receives a Notice.

- .2 Where the Surety includes two or more companies, the Notice may be delivered to the first listed Surety on behalf of all Sureties. The first listed Surety is hereby authorized to respond to the Notice on behalf of the Sureties, and the Owner is not required to give separate Notice to each Surety and is entitled to correspond with the first listed Surety on behalf of all Sureties.

## 2. PRE-NOTICE MEETING

- .1 The Owner may, at its sole discretion and acting reasonably, request a pre-Notice conference by notifying the Surety and the Contractor in writing that it is considering declaring the Contractor to be in default under the Contract (the "Pre-Notice Meeting"). This notice and request for a Pre-Notice Meeting by the Owner does not constitute a Notice under this Bond, nor under the Contract, nor is it a precondition to the giving of a Notice. Upon receipt of such request the Surety shall propose a face-to-face meeting, a telephone conference call or a meeting by any other form of electronic media between the Contractor, the Owner and the Surety to take place at a time and place mutually convenient for all parties within seven (7) business days (or such longer time as agreed by all parties) after the Surety's receipt of the Owner's request for a Pre-Notice Meeting in accordance with this Section. The Owner, the Contractor and the Surety shall make reasonable efforts to arrange and attend the Pre-Notice Meeting. In the event that the Owner delivers a Notice prior to the Pre-Notice Meeting, then the Pre-Notice is deemed to be retracted.
- .2 The purpose of a Pre-Notice Meeting is to allow the Owner, prior to exercising its other rights under this Bond, to express any concerns about the Contractor's performance pursuant to the Contract and to allow the Contractor to respond to such concerns. The participation of the parties in one or more Pre-Notice Meetings shall be without prejudice to their respective rights and obligations under the Contract, this Bond or applicable law, and neither the participation by any party in any Pre-Notice Meeting, nor any statement or position taken or information provided by any party during any Pre-Notice Meeting, may be relied on by any other party as a waiver or compromise of the rights or obligations of the Owner, the Surety or the Contractor under the Contract, this Bond or applicable law; including, but not limited to the Owner's right to declare the Contractor in default under the Contract and give Notice under this Bond.



### 3. SURETY'S INVESTIGATION AND RESPONSE

- .1 Upon receipt of a Notice from the Owner, the Surety shall promptly initiate an investigation of the Notice (the "**Investigation**"), using its best efforts, to determine if the Conditions Precedent have been satisfied and to determine its liability, if any, under the Bond.
- .2 Within the four (4) business days following receipt of the Notice, the Surety shall provide the Owner with an acknowledgement, substantially in the form set out as Schedule B (the "**Acknowledgement**"), identifying the date on which the Notice was received and requesting from the Owner the information and documentation (the "**Information**") the Surety requires to continue the Investigation and, if necessary, request access to personnel who are knowledgeable about the circumstances of the Notice and to the Contract work site(s) where the work is being performed. Upon receipt of the Surety's Acknowledgement, the Owner shall promptly, and in accordance with terms of the Contract, provide the Surety with the requested Information and access to personnel and the work site(s) within its possession or control.
- .3 The Surety shall within a reasonable time conduct the Investigation, but in any event no later than twenty (20) business days after receipt by the Surety of a Notice (or such longer period as may be agreed between the Surety and Owner), the Surety shall provide the Owner with its written response to the Notice, substantially in the form set out at Schedule C (the "**Surety's Position**"), advising either that:
  - a) The Surety accepts liability under the Bond and proposes to satisfy its Obligation by performing one of the options set out in Section 6.1; or
  - b) The Surety does not accept liability, providing its specific reasons; or
  - c) The Surety is unable to determine whether or not one or more of the Conditions Precedent has been satisfied and, in the Surety's sole discretion, the Surety may propose a process for collaborating with the Owner in the advancement of the completion of the work so as to attempt to mitigate the Owner's cost to complete the Contract.
- .4 The Surety shall also, if requested by the Owner to do so, meet with the Owner to discuss the status of the Investigation within five days following receipt of the request. This meeting may take place via a face-to-face meeting, a telephone conference call or a meeting by any other form of electronic media as may be mutually agreed to by the Owner and Surety.

#### 4. NECESSARY INTERIM WORK

- .1 Prior to and during the Investigation, if the Owner must take action which is necessary to:
  - a) ensure public or worker safety,
  - b) preserve or protect the work under the Contract from deterioration or damage, or
  - c) comply with applicable law,

The Owner may, acting with due diligence and provided written notice is subsequently provided to the Surety within three (3) Business Days of the commencement of such Necessary Interim Work provided that:

- i. Owner shall allow the Surety and/or its consultant(s) reasonable access to the Contract work site(s) during the course of the Necessary Interim Work for the purpose of monitoring the progress of the Necessary Interim Work;
  - ii. Any such Necessary Interim Work shall be undertaken without prejudice to the rights of the Owner, the Contractor or the Surety under the Contract, this Bond or applicable law; and
  - iii. The reasonable costs incurred by the Owner in undertaking such Necessary Interim Work (to the extent they are not deducted in the calculation of the Balance of Contract Price in Section 9.1) shall be reimbursed by the Surety, subject to the Surety's liability being subsequently established and subject to such expenses being covered by this Bond. Any payments made by the Surety in respect of the Necessary Interim Work shall reduce the Bond Amount by the amount of any such payments.
- .2 Nothing in this section is intended to limit the ability of an Owner to take whatever steps are reasonably necessary in the public interest.
- .3 Subject to the foregoing provisions in Section 4.1, the Surety shall not raise the mere fact that the Necessary Interim Work proceeded as a defense to any claim by the Owner hereunder.

#### 5. POST-NOTICE CONFERENCE

- .1 Upon receipt of a Notice, the Surety shall propose a face-to-face meeting, telephone conference call or a meeting by any other form of electronic media (a "**Post-Notice Conference**") with the Owner at a mutually convenient time and place within five (5) business days (or such longer period as may be agreed between the Surety and Owner). The Contractor may participate in a Post-Notice Conference at the invitation of the Surety.

- .2 The purpose of the Post-Notice Conference shall be to determine what actions or work, if any, the Owner believes must be done while the Surety is conducting the Investigation in order to effectively mitigate the costs for which the Owner is seeking recovery under this Bond (the **"Mitigation Work"**). Mitigation Work may be performed after Necessary Interim Work and throughout the period of investigation by the Surety.
  - .3 Provided the Owner provides reasonable evidence to the Surety that Mitigation Work is necessary during the Investigation and that the anticipated costs are reasonable, the Owner may proceed with the Mitigation Work subject to the following conditions:
    - a) Owner shall pay the reasonable costs of the Mitigation Work;
    - b) Owner shall keep separate records of all amounts related to the Mitigation Work for which it intends to seek recovery under this Bond, including amounts to be set off against the Balance of Contract Price;
    - c) Owner shall allow the Surety and/or its consultant(s) reasonable access to the Contract work site(s) during the course of the Mitigation Work for the purpose of monitoring the progress of the Mitigation Work; and
    - d) the Mitigation Work shall be without prejudice to the rights or obligations of the Owner, the Contractor or the Surety under the Contract, this Bond or applicable law.
  - .4 If the Surety objects to any part of the Mitigation Work, including without limitation the Owner's proposed Mitigation Work contractor(s), scope of work, cost or method of work, it shall immediately advise the Owner in writing of its objections and the reasons therefor. The Owner may still proceed with the Mitigation Work and the Surety's objections will be addressed through negotiation with the Owner or at the trial of any action brought pursuant to this Bond.
  - .5 The reasonable costs incurred by the Owner in undertaking the Mitigation Work shall be reimbursed by the Surety, subject to the Surety's liability being subsequently established. Any payments made by the Surety in respect of the Mitigation Work shall form part of its Obligation under this Bond and shall reduce the Bond Amount by the amount of any such payments.
  - .6 For greater clarity, any Necessary Interim Work being performed by the Owner pursuant to Section 4 may continue to be performed pending an agreement, if any, as to the Mitigation Work.
  - .7 Subject to the foregoing provisions in this Section 5, the Surety shall not raise the mere fact that the Mitigation Work proceeded as a defense to any claim by the Owner hereunder.
-

## 6. SURETY'S OPTIONS

- .1 If the Surety has accepted liability pursuant to this Bond, the Surety shall promptly select and commence one of the following options:
  - a) remedy the default; or
  - b) complete the Contract in accordance with its terms and conditions; or
  - c) obtain a bid or bids for submission to the Owner for completing the Contract in accordance with its terms and conditions and, upon determination by the Owner and the Surety of the lowest responsible bidder:
    - i. arrange for a contract between such bidder and the Owner; and
    - ii. make available as work progresses (even if there should be a default, or a succession of defaults, under the contract or contracts of completion, arranged under this paragraph) sufficient funds to complete the Contractor's obligations in accordance with the terms and condition of the Contract including any applicable value-added taxes for which the Surety may be liable, less the Balance of Contract Price; or
  - d) pay the Owner the lesser of: (1) the Bond Amount, or (2) without duplication, the Owner's Direct Expenses plus the Owner's proposed cost of completion of the Contract and any applicable value-added taxes for which the Surety may be liable, less the Balance of Contract Price.
- .2 The option selected by the Surety is referred to in this Bond and the Schedules as the "**Surety Option**".

## 7. OWNER'S DIRECT EXPENSES

- .1 Where the Surety is liable under this Bond, then the Surety shall be liable for the following fees and expenses, without duplication (the "**Owner's Direct Expenses**"):
    - a) reasonable professional fees incurred by the Owner to complete the Contract which are a direct result of the Contractor's default and which would not have been incurred but for the default of the Contractor;
    - b) reasonable external legal fees incurred by the Owner to complete the Contract, which are a direct result of the Contractor's default and which would not have been incurred but for the default of the Contractor, with the exception of legal fees incurred by the Owner in defending a claim or action by the Contractor, or incurred by the Owner in pursuing an action against the Contractor;
-

- c) reasonable, miscellaneous and out-of-pocket expenses incurred by the Owner to complete the Contract which are a direct result of the default of the Contractor and which would not have been incurred but for the default of the Contractor;
  - d) direct costs incurred as a result of an extension of the duration of the supply of services or materials used or reasonably required for use in the performance of the Contract, which are a direct result of the default of the Contractor and which would not have been incurred but for the default of the Contractor;
  - e) reasonable costs of the Necessary Interim Work;
  - f) reasonable costs of the Mitigation Work; and
  - g) any additional fees and expenses agreed to by the Obligee, the Principal and the Surety.
- .2 For the purpose of Section 7.1(d), the “direct costs” incurred are the reasonable costs of performing the Contract during the extended period of time, including costs related to the additional supply of services or materials (including equipment rentals), insurance and surety bond premiums, and costs resulting from seasonal conditions, that, but for the extension, would not have been incurred.
- .3 Subject to any agreement to the contrary, between the Obligee, the Principal and the Surety, the Surety shall not be liable under this Bond for:
- a) any liquidated damages under the Contract;
  - b) if no liquidated damages are specified in the Contract, any damages caused by delayed performance or non-performance of the Contractor, except as provided in Section 7.1(d); or
  - c) any indirect or consequential damages, including but not limited to costs of financing, extended financing, hedging arrangements, loss of or deferral of profit, productivity or opportunity, or head office overhead costs.
- .4 If the Surety is liable under this Bond then, at the Owner’s option, Owner’s Direct Expenses may be deducted by the Owner from the Balance of the Contract Price as defined hereinafter or will be promptly reimbursed by the Surety subject to the other terms, conditions and limitations of this Bond and will reduce the Bond Amount.

## 8. CONDITIONS PRECEDENT

- .1 The Surety shall have no liability or Obligations under this Bond unless all of the following conditions precedent (the “**Conditions Precedent**”) have been satisfied:
-

- a) The Contractor is, and is declared by the Owner to be, in default under the Contract;
- b) The Owner has given such notice to the Contractor of a default of the Contractor, as may be required under the terms of the Contract;
- c) The Owner has performed the Owner's obligations under the Contract; and
- d) The Owner has agreed to pay the Balance of Contract Price to the Surety or as directed by the Surety.

## 9. BALANCE OF CONTRACT PRICE

- .1 The term "**Balance of Contract Price**" means the total amount payable by the Owner to the Contractor under the Contract, including any adjustments to the price in accordance with the terms and conditions of the Contract, or other amounts to which the Contractor is entitled, reduced by any amounts deducted by the Owner for the Owner's Direct Expenses under Section 7.4 and all valid and proper payments made to or on behalf of the Contractor under the Contract.
- .2 The Balance of Contract Price shall be used by the Owner to first mitigate against any potential loss to the Surety under this Bond and then under the Labour & Material Payment Bond, when necessary, and the Owner shall assert all rights and remedies available to the Owner to the Balance of Contract Price and make payment of the Balance of Contract Price as directed by the Surety.

## 10. LIMITATIONS ON THE SURETY'S LIABILITY

- .1 Notwithstanding anything to the contrary contained in this Bond or in the Contract, the Surety shall not be liable for a greater sum than the Bond Amount under any circumstances.
- .2 The Surety's responsibility to the Owner under this Bond in respect of any Surety Option or Owner's Direct Expenses shall not be greater than that of the Contractor under the Contract.

## 11. RIGHT OF ACTION

- .1 No right of action shall accrue on this Bond to or for the use of any person or corporation other than the Owner named herein, or the heirs, executors, administrators or successors of the Owner.

## 12. COMMENCEMENT OF ACTION

- .1 It is a condition of this Bond that any suit or action must be commenced before the expiration of two (2) years from the earlier of: (a) the date of substantial performance of the Contract as defined under the *Construction Act* (the "**Act**"); or (b) the date on which a Notice in respect of the default that is the subject of such suit or action is received by the Surety under this Bond.
- .2 The Owner, the Contractor and the Surety agree that any suit or action is to be made to a court of competent jurisdiction in Ontario and agree to submit to the jurisdiction of such court notwithstanding any terms to the contrary in the Contract.

## 13. COMMON LAW RIGHTS

- .1 The rights and obligations of the Owner, the Contractor, and the Surety under this Bond are in addition to their respective rights and obligations at common law and in equity.

## 14. APPLICABLE LAW

- .1 This Bond is governed by the laws of the Province of Ontario.

## 15. NOTICES

- .1 All notices under this Bond shall be delivered by registered mail, facsimile, or electronic mail at the addresses set out below, subject to any change of address in accordance with this Section. Any notice given by facsimile or electronic mail shall be deemed to have been received on the next business day or, if later, on the date actually received if the person to whom the notice was given establishes that he or she did not, acting in good faith, receive the notice until that later date. Any notice given by registered mail shall be deemed to have been received five (5) days after the date on which it was mailed, exclusive of Saturdays and holidays or, if later, on the date actually received if the person to whom the notice was mailed establishes that he or she did not, acting in good faith, receive the notice until that later date. A change of address for the Surety is publicly available on the Financial Services Commission of Ontario website ([https://www5.fSCO.gov.on.ca/Licensing/LicClass/eng/lic\\_companies\\_class.aspx](https://www5.fSCO.gov.on.ca/Licensing/LicClass/eng/lic_companies_class.aspx)). The address for the Owner or the Contractor may be changed by giving notice to the other parties setting out the new address in accordance with this Section.
-

**16. HEADINGS FOR REFERENCE ONLY**

- .1 The headings and references to them in this Bond are for convenience only, shall not constitute a part of this Bond, and shall not be taken into consideration in the interpretation of this Bond.

IN WITNESS WHEREOF, the Contractor and the Surety have Signed and Sealed this Bond, this..... day of ..... in the year.....

**[Contractor proper name]**

\_\_\_\_\_ Witnessed by:  
 By: \_\_\_\_\_  
 Name: \_\_\_\_\_ Name of Witness: \_\_\_\_\_  
 Title: \_\_\_\_\_ Address of Witness: \_\_\_\_\_  
 I have authority to bind the corporation.

**[Surety corporate name]**

\_\_\_\_\_

By: \_\_\_\_\_ By: \_\_\_\_\_  
 Name: \_\_\_\_\_ Name: \_\_\_\_\_  
 Attorney-in-fact: \_\_\_\_\_ Attorney-in-fact: \_\_\_\_\_

\* IF THERE ARE TWO OR MORE COMPANIES IN PARTNERSHIP OR JOINT VENTURE, JOINTLY AND SEVERALLY BOUND, INSERT THE NAME OF EACH PARTNER OR JOINT VENTURE PARTY, AND INSERT THE WORD "COLLECTIVELY" AFTER THE WORD "HEREINAFTER" IN THE FIRST LINE.

\*\* IF THERE ARE TWO OR MORE SURETY COMPANIES, JOINTLY AND SEVERALLY BOUND, INSERT THE "[Name of the surety company], a corporation created and existing under the laws of [Place of incorporation]," FOR EACH SURETY, FOLLOWED BY "each as a surety and each duly authorized to transact the business of Suretyship in the Province of Ontario and hereinafter collectively called the "Surety".

\*\*\* INSERT THE CROWN, A MUNICIPALITY OR A BROADER PUBLIC SECTOR ORGANIZATION, AS APPLICABLE, OR SUCH OTHER PARTY DEEMED TO BE THE OWNER UNDER THE ACT, AND ENTERING INTO THE PUBLIC CONTRACT WITH THE CONTRACTOR.

This document is *FORM 32 PERFORMANCE BOND UNDER SECTION 85.1 OF THE ACT*, The "Construction Act of Ontario" as created by the Province of Ontario and provided to Kingston & Frontenac Housing Corporation by Surety Association of Canada May 11, 2018.

**END OF SECTION**



## 1.0 GENERAL

### 1.1 Definitions

- .1 "Owner" means **Town Homes Kingston**.

### 1.2 Instructions

- .1 Before submitting a bid, Bidders shall:
- .1 Examine and read the Bid Documents thoroughly.
  - .2 Examine the site and ascertain the extent and nature of all conditions, limitations, or building regulations affecting the performance of the Work. The site is open and available for review by the Bidders during normal business hours. Coordinate site access through the Manager of Technical Services. All dimensions are to be confirmed by on-site measurement by the Bidder.
  - .3 Confirm all utility services in the vicinity of the Work that will require protection and maintenance during the course of the Work.
  - .4 Consider the effect of regulatory requirements applicable to the Work.
  - .5 Study and correlate Bidder's observations with the Bid Documents.
  - .6 Immediately notify the Owner of all perceived omissions and discovered conflicts, errors and discrepancies in the Bid Documents.
  - .7 Be satisfied that Bidder understands the Bid Documents and is competent to undertake and complete the Work.
- .2 Bid shall include cost of all permits required (excluding the building permit), royalties, freight, government duties and taxes where applicable.
- .3 The Owner will obtain and pay for the Municipal Building Permit when required by the Ontario Building Code.
- .4 In the event of any change in any applicable tax made public after the date of tender closing, the Contract Price shall be adjusted by an amount equal to the increase or decrease in the cost of the Work to the Contractor brought about by the change in such tax.
-

- .5 The Owner reserves the right to add or delete items to be performed under this Contract before and after the Contract is awarded without any penalty. Any revisions to the submitted Contract Price as a result of these deletions are to be solely based on the unit prices (or lump sum prices) quoted by the Bidder for those items.
- .6 The Bidder shall not engage in collusion of any sort and, in particular, shall ensure that no person or other legal entity other than the Bidder has an interest in the Bidder's bid. The bidder shall prepare the bid without any knowledge of, comparison of figures with, or arrangement with any other person or firm preparing a bid for the same work.
- .7 It is the Bidder's responsibility to provide all labour, material, equipment and supervision to complete the repairs outlined in these Bid Documents taking into account all site conditions, schedule and noise restrictions, work area restrictions, protection requirements, accessibility restrictions, etc. No extras will be entertained for inconveniences after award of the Contract.
- .8 Bidder shall read the Bid Documents in their entirety prior to bidding in order to be aware of all project requirements.
- .9 If the Bidder is a joint venture, each party to the venture must execute the bid under seal in the manner appropriate to such party.

### **1.3 Form of Contract**

- .1 The Owner will issue an Award Letter which shall be the basis for acceptance of the Bid by the Owner and Award of the Contract to the Contractor. The Award Letter will describe information required by the Owner; namely, Performance Security and Insurance Certificate requirements.
- .2 Upon receipt of the documents outlined in the Award Letter, a Contract, as amended by the General Conditions, will be raised by the Owner and issued to the Contractor.

### **1.4 Employment Equity**

- .1 In accordance with the employment equity goals, Kingston & Frontenac Housing Corporation encourages bidders to take an active role in supporting and facilitating opportunities for employment equity designated groups.
-

## 1.5 Owner and Owner's Representative

- .1 The Owner is: [Town Homes Kingston  
610 Montreal Street  
Kingston, ON K7K 3J2](#)
- .2 The Owner's Representative is: Scott VanderSchoor,  
Manager of Technical Services  
Kingston & Frontenac Housing Corporation  
119 Van Order Drive Kingston, ON K7M 1B9  
Tel: (613) 546-5591 ext. 1560  
Fax: (613) 546-9375  
Email: [svanderschoor@kfhc.ca](mailto:svanderschoor@kfhc.ca)
- .3 The Project Consultant is: [Rob Asselstine, Civil Technician  
Greer Galloway Consulting Engineers  
640 Cataraqui Woods Drive, Unit 2A  
Kingston, ON K7P 2Y5  
Tel: \(613\) 536-5420 ext. 205  
Fax: \(613\) 548-3793  
Email: \[rasselstine@greergalloway.com\]\(mailto:rasselstine@greergalloway.com\)](#)
- .4 Any questions during the Bid Period shall be directed to the office of the Representative.
- .5 Addenda will be issued in all cases where questions result in changes or clarification to BID DOCUMENTS.

## 1.6 Pre-Bid Closing Site Meeting

- .1 A **MANDATORY** pre-bid closing site inspection and meeting will be held on site at **11:00 a.m. on Thursday, March 21, 2019** for the benefit of all Bidders. Bidders should meet at **375 Patrick Street, unit B1, Kingston, Ontario.**

## 1.7 Examination of Site

- .1 The onus shall be on the Bidder to investigate the Project Site and inform themselves before bidding of all physical and labour conditions and administrative practices prevailing at the project site.
  - .2 The Bidder shall not claim at any time after the submission of their bid any misunderstanding of the terms and conditions of the Contract relating to the site conditions.
-

- .3 The Bidder shall make allowances as required for the installation of temporary services (heating and ventilators, etc.) into and out of the work area. No extra for this item will be entertained after bids have closed.

## 1.9 Bid Submission

- .1 Completed Bid Forms together with the required bid security, consents of surety and all supplementary bid submission material, including **Appendix A** shall be delivered to the office of the Owner's Representative in a sealed envelope no later than **11:00:00 a.m. on Thursday, March 28, 2019** and addressed as follows:

**Confidential:**                    **Bid Submission**  
**Kingston & Frontenac Housing Corporation**  
**119 Van Order Drive**  
**Kingston, ON K7M 1B9**

**Attention:**                    **Scott VanderSchoor**  
**Manager of Technical Services**

**Tender Number:**                **THK PT 19-03**  
**Tender Description:**            **Front Steps Replacement**

- .2 Bidder's name shall be typed on the reverse side of the envelope.
- .3 Bids will be opened publically at the office of the Owner's Representative.
- .4 Using the Bid Form provided, the bid shall be filled out in ink or typed, signed in longhand by a duly authorized company official, and sealed with the Bidder's corporate seal.
- .5 The Bid Form shall not be altered and all spaces for information will be completed.
- .6 The Owner's Representative may, after bid closing time and before Contract award, require any Bidder to submit, in a form prescribed by or acceptable to the Owner's Representative, supplementary information about any aspect of the Bidder's bid that, in the Owner's Representative's opinion, is necessary for bid evaluation purposes.
- .7 Failure to fulfil the requirements of the Bid Documents will result in disqualification at the sole discretion of the Owner's Representative.
- .8 Offers submitted after the specified time will be returned to the bidder unopened.

- .9 Verbal or electronically submitted information will not be accepted as part of the bid documents.
- .10 Bidders must not submit the entire tender specification documents with their bid submission forms.

### **1.9 Bonding Requirements**

- .1 A bid deposit in the form of a certified cheque or bid bond made payable to the Owner in the amount of \$3,000.00 shall accompany all bids.
- .2 The Bidder shall provide the Owner with performance security as outlined in Section 00 72 13 – General Conditions, a consent of surety to provide these bonds shall accompany the Bid, if applicable.
- .3 All bonds shall name the Owner as obligee.
- .4 The amount must be as stipulated and valid for a period of sixty (60) days from the date of Bid Closing.
- .5 The cost of bonds is to be included in the bid lump sum prices.

### **1.10 Sufficiency of Bid**

- .1 The submission of a bid shall constitute an incontrovertible representation by the Bidder that:
  - .1 The Bidder has complied with all bid requirements.
  - .2 The Bidder is qualified and experienced to perform the Work in accordance with the Bid Documents.
  - .3 The bid is based upon performing the Work in accordance with the Bid Documents, without exception.
  - .4 The price or prices stated in the bid cover all the Bidder's obligations under the Contract and all matters and things necessary for the performance of the Work in accordance with the Bid Documents.

### **1.11 Bid Irregularities**

- .1 At the discretion of the Owner, bids that are unsigned, improperly signed or sealed, conditional, illegible, obscure, contain arithmetical errors,
-

- 
- erasures, alterations or irregularities of any kind may be accepted or declared informal.
- .2 At the discretion of the Owner, bids that fail to include or to comply with bid security, bonding or insurance requirements may be accepted or declared informal.
  - .3 Informal bids may or may not be considered at the sole discretion of the Owner.
  - .4 The Owner may accept or waive a minor and inconsequential irregularity, or where practicable to do so, the Owner may, as a condition of bid acceptance, request a Bidder to correct a minor and inconsequential irregularity with no change in bid price.
  - .5 The determination of what is, or is not, a minor and inconsequential irregularity, the determination of whether to accept, waive, or require correction of an irregularity, and the final determination of the validity of a bid, shall be at the Owner's sole discretion.
  - .6 Discrepancies between words and figures will be resolved in favour of words.

#### **1.12 Bid Withdrawal and Acceptance**

- .1 The Owner reserves the right to reject any or all bids as the interests of the Owner may require, without stating reasons therefore, and the lowest or any bid will not necessarily be accepted.
- .2 A Bidder who has already submitted a bid may submit a further bid at any time up to the official closing time. The last bid that is received shall supersede and invalidate all previously submitted bids by that Bidder for this Contract.
- .3 A bid may be withdrawn at any time before the bid closing time, provided the request is in the form of a letter received at the office of the Owner's Representative before the bid closing time.
- .4 Withdrawn bids may be resubmitted in accordance with these bidding requirements providing the resubmitted bid is received at the office of the Owner's Representative before the bid closing time.
- .5 A bid may not be withdrawn at or after bid closing time and shall be open to acceptance by the Owner until whichever of the following occurs first:
  - .1 Another Bidder has entered into a Contract with the Owner for performance of the Work.

- .2 Sixty (60) days after the bid closing time.
- .6 The sixty (60) day acceptance period shall commence at midnight at the date of bid closing and shall terminate at midnight of the sixtieth (60th) day thereafter. If the sixtieth (60th) day falls on a statutory holiday, such day(s) shall be omitted from the computation.
- .7 The sixty (60) day acceptance period may be extended at the Owner's request and subject to the Bidder's written agreement to the extension.
- .8 If a Bidder withdraws his Bid after the Bid closing or if the Bidder does not provide Performance Security, Certificate of Liability Insurance or any other document required; the Owner may retain the Bid Security for its use.
- .9 In the case of an error in addition, the correct sum of the amounts shown for each bid item shall be deemed to be the total bid price regardless of the total amount submitted by the Bidder.
- .10 Evaluation of Bid

In evaluating the bids, the Owner may consider any criteria, with such consideration to be exercised by the Owner in its sole discretion, including the following:

- .1 The Contract Price as determined from the base bid or from the alternate bid.
  - .2 The Owner's authorized budget for the Work.
  - .3 The Contract Time.
  - .4 The Bidder's ability to effectively manage and perform the Work and work with other subcontractors.
  - .5 The Bidder's understanding of the Work.
  - .6 The Bidder's Unit Prices, Allowances, and Separate Prices, if applicable.
  - .7 The Bidder's ability to present cost saving opportunities that may be appropriate and acceptable to the Consultant and the Owner.
-

- 
- .8 The Bidder's experience, competence and past performance in undertaking work similar to the Work, as well as that of its subcontractors.
  - .9 The Bidder's financial strength and capability.
  - .10 The experience, qualifications and abilities of the Bidder's supervisory personnel.
  - .11 Aesthetic changes resulting from the Bidder's proposed approach to the Work.
  - .12 Other criteria which the Owner, in its sole discretion, may consider appropriate to its evaluation.
- .11 Acceptance of Bid
- .1 The lowest or any bid need not be accepted by the Owner. The Owner reserves the right to accept or reject any or all bids at their sole discretion on any basis at any time without further explanation or to accept any bids considered advantageous to the Owner.
  - .2 The Bidder acknowledges and agrees that the Owner will not be responsible for any costs, expenses, losses, damages or liabilities incurred by the Bidder as a result of or arising out of submitting a bid for the proposed Contract, or due to the Owner's acceptance or non-acceptance of their bid.
  - .3 The Owner may also elect not to proceed with the Project.
  - .4 Where all other factors are equal, lowest price shall govern. Where all factors are equal, including price, the Buyer shall select the successful Vendor based on a coin toss, which shall be conducted in the presence of the tied Prospective Vendors should they wish to attend. Award shall then be made to the winner of the coin toss.
  - .5 In the event that three or more tied or identical Bids remain following evaluation, the Buyer shall select the successful Vendor based on a lottery draw, which shall be conducted in the presence of the tied Prospective Vendors should they wish to attend. The Award shall then be made to the winner of the lottery.

#### **1.15 Canadian Content**

- .1 The Owner reserves the right to give preference to materials, products and equipment of Canadian origin and manufacture.



### **1.16 Addenda**

- .1 Direct all questions in writing to the Owner's Representative.
- .2 Answers to queries are only binding when confirmed by written Addenda.
- .3 Clarifications requested by Bidders must be submitted in writing to the Owner's Representative no less than four (4) days before the date set for receipt of the bids. Any reply will be in the form of an Addendum, a copy of which will be forwarded to known Bidders no less than two (2) days before the date set for receipt of the bids.
- .4 Addenda may be issued by the Owner's Representative during the bid period. Any Addenda will be delivered by the Owner's Representative via email or courier to all parties recorded by the Owner's Representative as having received the Bid Documents.
- .5 All Addenda become part of the Bid and Contract Documents and the costs arising from any Addenda are to be included in the bid price.
- .6 Each Bidder shall ascertain before bid submission that all Addenda issued by the Owner's Representative have been received and the Bidder shall indicate in the Bid Form the addendum number(s) of all Addendum received.

### **1.17 Construction Schedule**

- .1 Refer to schedule requirements outlined in Section 01 10 01 – General Requirements.
- .2 The Contractor will complete the work within the time specified in the Purchase Order or Contract.
- .3 TIME IS OF THE ESSENCE OF THE CONTRACT.

### **1.18 Qualifications**

- .1 Persons of Bidders submitting bids for this Project shall be actively engaged and experienced in the type of work required by these Bid Documents and the Bidder shall provide, on request, a statement of similar work performed by those persons.

**END OF SECTION**

---

## 1.0 GENERAL

### 1.1 Definitions

- .1 Whenever any of the following words or phrases are used in the contract, they shall have the meanings attributed to them, as follows:
  - .1 "Bid" means any bid, tender or offer submitted by a bidder pursuant to the Instructions to Bidders.
  - .2 "Owner" means **Town Homes Kingston**.
  - .3 "Owner's Representative" means **Kingston & Frontenac Housing Corporation**.
  - .4 "Contractor" means the person, firm or corporation identified on the Purchase Order responsible for the work of this contract.
  - .5 "Contract Price" means the total price including tax the Owner has agreed to pay the Contractor for the work stipulated in the Contract, and in any event shall not exceed the amount specified in the Contract.
  - .6 "Business Day" means any day except a Saturday, Sunday or statutory holiday.
  - .7 "Building Code" means the Ontario Building Code (latest edition).
  - .8 "As detailed" means as shown on the drawings.
  - .9 "As specified" means as specified herein.
  - .10 "Provide" means supply and install.
  - .11 "Controlled" has the same meaning as in subsection 1 (5) of the Business Corporation Act.

### 1.2 Precedence of Documents and Interpretation

- .1 Whenever the words "shall" or "will" are used in the Contract, they have the meanings attributed to them in the Interpretation Act of Ontario.
  - .2 Whenever words which have well known technical or trade meanings are used in the Contract, they are used in accordance with such recognized meanings.
  - .3 The documents forming the Contract are complementary, and what is
-

required by any one shall be as binding as if required by all.

The following documents all form part of the Contract:

- Instructions to Bidders
- Supplementary Conditions
- General Conditions
- Bid Form
- Specifications with Appendices and Addenda
- Schedules
- Drawings
- Award Letter
- Purchase Order

- .4 In the event of conflict between documents, the following priorities shall apply:
- Documents of later date shall govern;
  - Supplementary Conditions shall govern over General Conditions;
  - General Conditions shall govern over Specifications;
  - Specifications shall govern over Drawings;
  - Figured dimensions shown on the Drawings shall govern even though they may differ from scaled dimensions.
  - Drawings of larger scale shall govern over those of smaller scale of the same date.

### 1.3 Performance Security

- .1 The Contractor shall provide performance security in favour of the Owner in order to secure the due and faithful performance of the contract. Such performance security will be as follows:
- .1 A Performance Bond issued by a Surety Company acceptable to the Owner in an amount equal to 50% of the Contract Price including tax.
  - .2 If the Contract Price including tax is less than \$1,000,000, the bond alternative forms of security must be equivalent to **20%** of the Contract Price. In each case, the following alternate forms of security are acceptable:
    - .1 an irrevocable letter of credit, bank draft, or certified cheque; or
    - .2 bearer or negotiable bonds of Dominion of Canada, Province of Ontario, or the Ontario Hydro Electric Power Commission (bonds to be assessed at market not face value); or
    - .3 such other collateral, excluding a letter of guarantee, as may be acceptable to the Owner.
-

- .3 For contracts under \$100,000 in value, the alternate forms of security are reduced to 10% of the contract amount.
- .4 If the Contractor fails to meet these requirements within the time stipulated by the award letter, the Owner retains the right to terminate the contract and use the bid security towards damages.
- .5 Where security is in the form of a Performance Bond, the document will be retained by the Owner for a period of two (2) years from the date of substantial completion, after which it will be returned to the Contractor.
- .6 Where alternate security is provided, it will be returned to the Contractor ninety (90) days after completion of the work and correction of all deficiencies.
- .7 Where deficiencies involve seasonal work which must be postponed, sufficient funds will be retained from the contract amount to cover the cost of completing such deficiencies and the Performance Security returned to the Contractor. Where contract funds are not available, the Performance Security may be reduced to the amount required to cover the correction of the deficiencies and the balance of the security returned to the Contractor.

#### **1.4 Insurance**

- .1 Contractor must keep in force for the duration of the contract Public Liability and Property Damage Insurance in an amount not less than \$2,000,000. Without limiting the foregoing, such Insurance Coverage shall include Comprehensive General Liability; Contractual Liability; Personal Injury; and Contingent Liability with respect to Sub-Contractors. Submit proof of same in the form of an Insurance Certificate which lists **Town Homes Kingston** as an additional insured but only with respect to the operations of the named insured. Such Insurance Certificate must contain a firm undertaking to give the Owner thirty (30) days notice prior to any cancellation.
- .2 If the Contractor fails to meet the requirements of this item within the time stipulated by the award letter, the Owner retains the right to terminate the contract and use the Bid Security toward damages.

#### **1.5 Workplace Safety & Insurance Board (WSIB)**

- .1 Contractor will submit, evidence of compliance with all of the requirements of the Workplace Safety & Insurance Board (WSIB) of Ontario, including payments due thereunder. Such evidence must be furnished to the Owner before final payment is made.
-

## 1.6 Assignment of Contract or Proceeds of Contract

- .1 The Contractor acknowledges that neither the Contract nor the proceeds thereof may be assigned without the written consent of the Owner.
- .2 Any contract entered into is binding upon the parties, their heirs and successors, and permitted assigns.
- .3 The contract cannot be assigned by the Contractor to any third party without the prior written consent of the Owner, which consent may be unilaterally withheld.

## 1.7 Taking The Work Out of the Contractors Hands

- .1 The Owner or Owner's Representative may, without any authorization, take all or part of the work out of the Contractor's hands and may employ such means as it may see fit to complete the work, including the use of Performance Security when applicable, in any of the following cases, namely:
    - .1 where the Contractor has made default or has delayed in commencing or in diligently executing the work or any portion thereof to the satisfaction of the person designated on the Purchase Order, and the Owner has given notice thereof to the Contractor, and has by such notice required the Contractor to put an end to such default or delay, and such default or delay continues for seven (7) days after such notice was communicated.
    - .2 where the Contractor has made default in the completion of the work, or any portion thereof, within the time limit for such completion by the Contract.
    - .3 where the Contractor has become insolvent.
    - .4 where the Contractor has committed an act of bankruptcy.
    - .5 where the Contractor has abandoned the work.
    - .6 where the Contractor has made an assignment of the Contract without the required consent of the Owner; or
    - .7 where the Contractor has otherwise failed to observe or perform any of the provisions of the Contract.
  - .2 Where the work or any portion thereof has been taken out of the Contractor's hands, the Contractor will not be entitled to any further payment, including payments then due and payable but not paid, and the obligation of the Owner to make payments shall be at an end, and the
-

Contractor shall be liable upon demand therefore to pay the Owner an amount equal to all loss and damage suffered by reason of the non-completion of the work by the Contractor.

- .3 Where the work or any portion thereof has been taken out of the Contractor's hands and that portion is subsequently completed by the Surety, or by the Owner or Owner's Representative, the Owner will determine the amount, if any, of the holdback and progress claims of the Contractor unpaid at the time of taking the work out of his hands that in the Owners opinion is not required for the purposes of the Contract and the Owner may, if it is of the opinion that no financial prejudice will result, pay that amount to the Contractor.
- .4 The taking of the work, or any portion thereof, out of the Contractor's hands does not operate so as to relieve or discharge the Contractor from any obligations under the Contract or imposed upon him by law, except the obligation to complete the physical execution of that portion of work so taken out of his hands.
- .5 The Owner may take the work out of the Contractor's hands if a construction lien has been filed against the project and the Contractor does not take immediate steps to have the lien removed.

## **1.8 Indemnification Claims**

- .1 Contractor will indemnify and save harmless the Owner and Owner's Representative from all claims relating to labour and materials furnished or supplied in executing the Contract and from and against all claims, demands, losses, costs, damages, actions, suits or proceedings by whomsoever made, brought or prosecuted in any manner based upon, arising out of, related to, occasioned by or attributable to the activities of the Contractor in performing the Contract, or to an infringement or an alleged infringement by the Contractor of a patent of invention.

## **1.9 Subcontractors**

- .1 On request, the Contractor will provide a complete and firm list of names and addresses of the subcontractors whom he will use for the work.
  - .2 Contractor agrees to:
    - .1 require his subcontractors to perform their work in accordance with and subject to the terms and conditions of the Contract Documents, and;
    - .2 be fully responsible to the Owner for acts and omissions of his subcontractors and of persons directly or indirectly employed by them as for acts and omissions of persons directly employed by him.
-

The Contractor therefore agrees that he will incorporate all the terms and conditions of the Contract Documents into all subcontract agreements.

- .3 nothing contained in the Contract Documents shall create any contractual relationship between any subcontractor and the Owner.

#### 1.10 The Residential Tenancy Act

- .1 In accordance with the Residential Tenancy Act, access to premises of residents may only be gained by permission of the resident, or as necessary, upon the landlord giving notice to the resident specifying the time of entry not less than twenty-four (24) hours prior to the time of entry.
- .2 Contractor must schedule his work accordingly and shall advise **Town Homes Kingston** not less than seventy-two (72) hours in advance of requested access to any residents' premises.

#### 1.11 Laws, Notices, Permits and Fees

- .1 The laws of the municipality where the project is situated shall apply to the work.
  - .2 Contractor will obtain all permits, licences and certificates and pay all fees required for the performance of the work.
  - .3 The Owner will obtain and pay for **BUILDING PERMITS** when required.
  - .4 Contractor will not be responsible for verifying that the Contract Documents are in compliance with the applicable laws, ordinances, rules, regulations and codes relating to the work. If the Contract Documents are at variance therewith, or changes which require modification to the Contract Documents are made to any of the laws, ordinances, rules, regulations and codes by the authorities having jurisdiction subsequent to the date of tender submission, any resulting change in the cost shall constitute a corresponding change in the Contract Price. Contractor must notify the Owner in writing requesting direction immediately on any such variance or change.
  - .5 If the Contractor fails to notify the Owner in writing and obtain its direction as required above and performs any work knowing it to be contrary to any laws, by-laws, ordinances, rules, regulations, codes and orders of any authority having jurisdiction, he shall be responsible for and shall correct any violations thereof and shall bear all costs, expense and damages attributable to his failure to comply with the provisions of such laws, by-laws, ordinances, rules, regulations, codes and orders.
-

### 1.12 Ontario Labour Conditions and Regulations

- .1 Persons employed on the work must be fully qualified to perform the work required. The Contractor will comply with the provisions of the Government Contracts Hours and Wages Act, the Construction Lien Act, R.S.O. 1990, c. C.30 including all subsequent updates, and the Ontario Health and Safety Act & Regulations for Construction Project.
- .2 The Contractor shall comply with Ontario Regulation 644/88 including all subsequent updates - Workplace Hazardous Materials Information System (WHMIS) wherever and whenever controlled products are used within the scope and duration of this Contract.
- .3 The Contractor will be responsible to ensure that the Ontario Human Rights Code is adhered to by the Contractor and all of their employees and subcontractors.

### 1.13 Toxic and Hazardous Substances

- .1 Prior to the Contractor commencing the Work, the Owner shall
  - .1 take all reasonable steps to establish whether or not any toxic or hazardous substances are present at the Place of the Work, and
  - .2 provide the Contractor with written report indicating all toxic or hazardous substances of such findings.
- .2 If the Contractor
  - .1 encounters toxic or hazardous substances at the Place of the Work, or
  - .2 has reasonable grounds to believe that toxic or hazardous substances are present at the place of the Work, the Contractor shall
  - .3 takes all reasonable steps, including stopping the Work to ensure that no person suffers injury, sickness or death and that no property is injured or destroyed as a result of exposure to the presence of the substances, and
  - .4 immediately reports the circumstance to the Owner in writing.

### 1.14 Award Letter and Contract

- .1 The Owner will issue an Award Letter which shall be acceptance of the Bid and award of the Contract to the Contractor. Award Letter will describe information required by the Owner namely Performance Security and Insurance Certificate.
-



- .2 Upon receipt of the above, a Contract will be raised.

**1.15 Completion Date**

- .1 The Contractor will complete the work within the time specified in the Purchase Order.
- .2 TIME IS OF THE ESSENCE OF THE CONTRACT.

**END OF SECTION**

## 1.0 GENERAL

Except as otherwise specifically stated, all obligations set out herein shall be on account of the Contractor and at the Contractor's sole expense.

### 1.1 Description Of Work

It is the Contractors responsibility to provide all labour, material, equipment and supervision to complete the work outlined in this specification, taking into account all site conditions, noise restriction, work area restrictions, protection requirements, accessibility restrictions, etc. No extras will be entertained for inconveniences after the award of this Contract.

### 1.2 Contractor's Use Of Site

- .1 The use of all equipment is to be restricted in accordance with noise by-laws as modified herein. Contractor has access to the work areas with quiet work proceeding around the clock if desired.
  - .2 Work will be carried out between the hours of 7:00 A.M. and 5:00 P.M. Monday through Friday. Work outside of these hours must be approved by the Owner.
  - .3 The Contractor has twenty-four (24) hour access to site; however, the use of the premises will be restricted due to user occupancy.
  - .4 The Contractor shall schedule their operation to minimize the interruption of the normal use of the site and building and to comply with laws, ordinances, rules and regulations relating to Work.
  - .5 The building is to remain open and operational through the Contract. It is the Contractor's responsibility to ensure the building remains operational and that areas outside those designated for closure remain available and safely accessible at all times.
  - .6 Do not unreasonably encumber the Place of Work with materials or equipment. Construction related debris shall not be permitted to accumulate on site where visible to building users. Remove daily if necessary.
  - .7 Do not overload the structure.
  - .8 Do not close or obstruct or store materials in roadways, sidewalks or passageways without prior approval from the Owner. Do not interfere with safe passage to and from the building and adjacent public sidewalks and
-

- roads. Move stored products or equipment that interferes with building operations.
- .9 Take all precautions and provide all required protection to ensure the safety of the general public.
  - .10 No storage of materials or equipment is allowed outside the designated work areas without the Owner's approval.
  - .11 During transportation of materials or equipment through occupied areas, ensure the public, property, and finishes are protected from damage. All damage caused by the Contractor is to be repaired or rectified at the Contractor's expense.
  - .12 Propane powered equipment not permitted within interior areas.
  - .13 Arrange all construction access into occupied areas with the Owner to allow the Owner to provide proper notice, where required.
  - .14 Maintain work areas and the vicinity clean and tidy to the satisfaction of the Owner and Consultant.
  - .15 The Contractor is to obtain and pay for all permits required for completion of the Work, excluding the Building Permit. Do not start construction until the Building Permit has been issued. Provide copies of all other permits to the Owner and Consultant and post on site where required.

### **1.3 Walkthrough Inspection of Site**

- .1 Prior to start of Work, the Contractor and Owner will perform walk-through inspection of the site to determine existing conditions. Owner to pay for elevator service personnel during inspection if applicable.
  - .2 The Contractor is to perform a thorough inspection of the site prior to the start of work and provide a written notice to the Owner that details all damaged property as well as all items that appear to be of poor working order or appearance (i.e. signs, fixtures, dirt, etc.).
  - .3 Upon receiving this notice, the Owner will review the validity of the items listed.
  - .4 If written notice is not given within five (5) days of commencement of Work, it will be assumed that the Contractor has reviewed the site and has accepted the condition of the property as being free of damage.
-

- .5 Any damages not listed as part of the written notice of clause 1.5.2 above found after the completion of the work will be the sole responsibility of the Contractor to rectify. These rectifications shall be completed in a timely and satisfactory manner.
- .6 The project will not be considered substantially performed if the cost to correct these outstanding deficiencies is greater than the limits outlined in the Construction Lien Act.

#### **1.4 Electrical Power**

- .1 Discuss available power with the Owner prior to bidding. Existing 110V power outlets may be used for small hand tools. No other power is available without prior written approval from the Owner. Alternatively, the Contractor may pay for alterations to the electrical system that are required to accommodate the Contractor's equipment. Co-ordinate alterations with the Owner and reinstate the system to the Owner's satisfaction upon completion.
- .2 Power consumption will be paid for by the Owner.

#### **1.5 Water Supply**

- .1 Water consumption will be paid for by the Owner.

#### **1.6 Sanitary Facilities**

- .1 Existing sanitary services, where available, may be used by the Contractor and his personnel on approval by the Owner. If not available at the specific project, the Contractor must provide this service at his own expense. Locate where agreeable to the Owner.
- .2 Provide all required signage necessary to protect the public from the construction and work area, control pedestrian and/or vehicular traffic flow, and to inform users that construction activity is in progress. Signage is to be of a professional quality and design to the Owner's satisfaction.

#### **1.7 Protection of Work and Property**

- .1 The Contractor shall take all reasonable precautions necessary to protect the Work and property from damage during performance of the Contract, and shall make good any damage to the Work or property caused by the Contractor or any of its Subcontractors.

- .2 Ensure all property is protected from dust and damage. Interior areas that require access outside of working hours are to be cleaned at the end of each work shift to provide a functional environment for the user.
- .3 Dust, dirt, construction debris, water and fumes from the Work must be contained so as not to affect areas that are to remain in operation outside of the designated work areas. Resulting damage caused by contamination is the responsibility of the Contractor.
- .4 The Contractor is responsible for any damage to all property, mechanical equipment, motors, elevator equipment, fixtures, air intakes, etc., resulting from dust contamination from the Work.
- .5 The Contractor shall completely enclose and ventilate the work areas (fresh air in and exhaust out) without allowing any dust to escape from the work area. The exhaust system must filter the dust out of the air before it is released into the atmosphere. All exhaust systems must be filtered and directed to the outside through ducting, which is to be installed in a manner acceptable to the Owner. Filters are to be cleaned and replaced regularly.
- .6 Protection shall be provided for all entrance and exit-ways, floors, walls and all standing fixtures, air intakes and equipment rooms.
- .7 Areas that are to be protected but still require access such as elevator lobbies and stairs will be hoarded using temporary vestibules. Pressurization to be adjusted by Contractor (by providing necessary fans) to prevent dust from entering these areas.
- .8 Contractor shall patch and repair all finishes or painted surfaces damaged during the course of the Work. This includes surfaces damaged by tape, fasteners, or similar materials during hoarding and protection.
- .9 Contractor shall not keep secure doors open for extended periods without the Owner's permission. Any resulting damage caused to building finishes or equipment, and any resulting property losses due to compromised building security, shall be the responsibility of the Contractor.

## **1.8 Protection of Existing Exposed Facilities/Services**

- .1 In general, no essential services such as electric power and domestic hot water supply are to be interrupted for more than one continuous hour, and no longer than three consecutive hours for the heating system during the heating season. In all cases, previous arrangements are to be made and approval obtained from the Owner.
-

- 
- .2 The Contractor shall make allowance in the price to cover all costs of temporary removal and replacement and/or relocation of existing electrical wiring and hardware required for completion of the Work.
  - .3 All exposed conduit, fixtures, attached devices, wet sprinkler fire system plumbing, mechanical system components, louvers and ducts are to be protected or Contractor to correct damages at their own expense. Contractor to promptly report any damage to the Owner.
  - .4 Prior to commencing the Work, contact the Owner to locate all protective or alarm systems and sensors. All services shall be protected against damage or interruption. Provide Owner with forty-eight (48) hours minimum advance notice of any necessary interruption. All claims resulting from damage shall be the responsibility of the Contractor.
  - .5 The Contractor shall restore landscaping beds in the area of work to their original plantable state after the work is complete. The Owner will arrange to remove and store for replanting, all landscaping including plants, shrubs, trees, etc. impacted by the work.

#### **1.9 The Work, Work in Progress, Property and Persons**

- .1 Protect the Work during construction from damage by weather.
  - .2 Protect existing buildings, walls, floors, ceilings, furnishings, equipment, plant materials, lawns, etc. from any damages resulting from performing work on this Contract. Any damages to be repaired without cost to the Owner.
  - .3 Protect new work from damages from any cause. All finished surfaces must be protected so that no marks or scratches mar the finished surfaces prior to acceptance of the work.
  - .4 Protect and be responsible for all new finished and unfinished work which is exposed and susceptible to vandalism or theft.
  - .5 Provide means for protecting occupied areas from water leakage between the removal and reinstallation of roofing systems, moisture barriers, sealants, etc.
  - .6 Take reasonable and required measures, including those required by authorities having jurisdiction, to protect the public and those employed on the Work from bodily harm.
  - .7 Comply with requirements of the Ontario Occupational Health and Safety Act and Regulations for Construction Projects.
-

- .8 The Contractor shall be prepared to provide respirators, dust protection, ear protection, hard hats, etc. for those employed by the Owner at the Site.
- .9 Direct all Subcontractors to protect their own work, existing property, adjacent public and private property and work of other Sections from damage while working.

#### **1.10 Location of Existing Utilities**

- .1 The contractor shall be responsible for arranging for the location of all existing utilities prior to construction and protection of it during construction.
- .2 Use the electrical service and water service at the site only as directed by the Owner.
- .3 Supply and pay for hoses, extension cords, special wiring or boxes as required.

#### **1.11 Fire Protection**

Contractor will:

- .1 Take necessary precautions to eliminate fire hazards and to prevent damage to the Work, building materials, equipment and other property both public and private having to do with the Work. Inspect the Work at least once a week for this purpose.
- .2 Store and locate products and equipment packed in cardboard cartons, wood crates and other combustible containers in orderly and accessible manner. Place approved types of firefighting equipment in vicinity of products packed in this type of crate or carton until permanent fire protection and equipment are available.
- .3 Store no flammable products such as paint or fuel in the parking garage without the Owner's permission in writing.
- .4 Ensure tarpaulins to be fire-resistant.
- .5 Ensure open fires or burning of rubbish or debris are not permitted on Site.

#### **1.12 Overhead Protection**

- .1 The Contractor shall erect and maintain pedestrian walkway including roof and side covers to protect the public and property from injury or damage.
-

- .2 Minimum extent of overhead protection as designated on drawings.
- .3 All overhead protection and enclosures to be marked with safety signage.
- .4 All overhead enclosures and protection to be maintained daily, keeping them clean, orderly and graffiti free.
- .5 Remove temporary facilities from site promptly when directed by Owner.

### **1.13 Work Site Safety – Contractor is “Prime Contractor”**

- .1 The Contractor shall, for the purposes of the Ontario Occupational Health and Safety Act, and for the duration of the Work and Contract:
  - .1 Be designated as “Prime Contractor” pertaining to safety at the “Work site”.
  - .2 Do everything that is reasonably practicable to establish and maintain a system or process that will ensure compliance with the Act and its regulations, as required to ensure the health and safety of all persons at the “Work site”.
- .2 The Contractor shall direct all subcontractors, workers and any other persons at the “Work site” on safety related matters, to the extent required to fulfill its “Prime Contractor” responsibilities pursuant to the Act.

### **1.14 Material and Equipment**

- .1 Unless otherwise specified, Contractor shall provide, maintain and pay for all materials, tools, machinery, equipment, temporary facilities, controls and conveniences necessary for execution of the Work. All materials shall be new, of merchantable quality, and suitable for the intended purpose.
- .2 Unless otherwise specified, comply with Manufacturer’s latest printed instructions for materials and installation methods. Notify the Consultant in writing of any conflict between the Contract Documents and Manufacturer’s instructions. Deliver, store and maintain packaged materials with Manufacturer’s seals and labels intact.

### **1.15 Coordination**

- .1 Co-operate with Kingston & Frontenac Housing Corporation and arrange for all work to be expedited with the minimum of inconvenience to all parties, and report in writing any difficulties encountered in expediting the work.
-



- .2 The Contractor is responsible for coordination of trades. Lines of demarcation between Contractor's work and trades' work are solely the responsibility of the Contractor. The Owner assumes no responsibility for division of the Work or for any jurisdiction regarding such division.
- .3 Contractor is responsible for coordination with the Owner of all on-site activity as it affects the operation of the building.
- .4 The Contractor is to notify the Building Inspector at least 72 hours in advance for site review where a Building Permit is required to perform the work. No work shall be covered or concealed until the Building Inspector has reviewed it, unless they have informed the Contractor that a site review will not be performed. Such review does not absolve the Contractor from their responsibility to perform the Work in accordance with the Contract Documents.

#### **1.16 Waste Removal and Cleaning**

- .1 The Contractor shall maintain the Place of the Work free from unsightly or hazardous accumulations of waste materials and rubbish, and shall perform all required cleaning during the Work. Area of work to be cleaned and swept daily.
- .2 All wastes, which create hazardous conditions, must be removed from the premises daily.
- .3 Disposal of all waste products to be performed in strict accordance with the product Manufacturer's Material Safety Data Sheet, and in accordance with the provincial Waste Control Regulations. Drainage systems shall not be used to dispose of Project wastes and materials.
- .4 Ensure all moisture sensitive equipment (i.e. exposed electrical and mechanical systems, etc.) are removed or protected against moisture infiltration during washing and dust-generating activities.
- .5 Remove all construction-related grease, dust, dirt, stains, labels, fingerprints, over-spray and other foreign materials immediately prior to the Consultant's final review. Return all adjacent areas, equipment, duct work, etc. to the Owner in a dust-free condition. Leave site in a neat and tidy condition at completion of the Work.

#### **1.17 Superintendence and Workmanship**

- .1 The Contractor shall provide a full time on-site Superintendent that is responsible for the quality, control, organization, and coordination of all
-

phases of the Work. The Superintendent shall be in attendance at all site meetings.

- .2 Superintendence shall be satisfactory to the Owner.
- .3 Superintendence shall be deemed unsatisfactory and changes or additions to superintendence can be demanded by the Owner when control, organization, or coordination of the Work is not adequate, the quality of the Work does not meet the Contract Document requirements, directions given in accordance with the Contract Documents are not followed, or progress is behind schedule.
- .4 Ensure that only experienced, skilled, and certified tradesmen are employed.
- .5 Repair, replace or otherwise make good all unacceptable or defective work.

## **2.0 PRODUCTS**

Not applicable

## **3.0 EXECUTION**

Not applicable

**END OF SECTION**

## 1.0 GENERAL

### 1.1 Payment and Holdbacks

- .1 For the purpose of the Construction Lien Act, R.S.O. 1990, c. C.30, the Payment Certifier shall be the Owner, or any person the Owner may designate from time to time as required by the Construction Lien Act, R.S.O. 1990, c. C.30, who shall:
  - .1 Determine and certify substantial performance; and
  - .2 Determine completion.

### 1.2 Applications for Payment

- .1 The Contractor shall submit a detailed schedule of values for the various components of the work in a form to the satisfaction of the Owner for review within ten (10) days of Award of Contract. This schedule of values shall form the basis by which progress draws are evaluated for completeness of the work performed.
- .2 Applications for payment on account may be made MONTHLY as the work progresses and submitted to Kingston & Frontenac Housing Corporation on behalf of Town Homes Kingston.
- .3 Before tax totals, all applicable taxes and totals must be shown separately on all invoices.
- .4 Payments will be due thirty (30) days after receipt of invoice.

### 1.3 Evidence of Publication

- .1 Upon completion of the work, the Payment Certifier will issue a Certificate of Substantial Performance. Contractor must then provide the Owner with evidence acceptable to it of publication. Holdback will be released on the sixtieth (60<sup>th</sup>) day from date of publication.

### 1.4 No Additional Payment for Increased Costs

- .1 The amount payable to the Contractor under the Contract will not be increased or decreased by reason of any increase or decrease in the cost of the work brought about by any increase or decrease in the cost of plant equipment, labour, materials or wage rates.
-

**1.5 Deductions for Uncorrected Work**

- .1 If in the opinion of the Payment Certifier, it is not expedient to correct defective work, or for work not done in accordance with the Contract Documents, the Owner may deduct from the Contract Price the difference in value between the work as done and that called for by the Contract.

**2.0 PRODUCTS**

Not applicable

**3.0 EXECUTION**

Not applicable

**END OF SECTION**

**SPECIAL PROVISIONS**

- Item No. 01: Removal and replacement of Deck Style # 1**
- Item No. 02: Removal and replacement of Deck Style # 2**
- Item No. 03: Removal and replacement of Deck Style # 3**

**375 Patrick Street - Decks Requiring Replacement**

Unit #	Deck Style
B1, B2, B3, B6, C1, C2, G2, G3, G6, G7, N1, N2	1
B7	2
E3/E4, H3/H4, L1/L2, L3/L4, L5/L6, M3/M4	3

The contract price for the above item(s) shall include full compensation for all labor, equipment and material required to perform the removal and reconstruction of the entrance and exit decks for the townhomes located at 375 Patrick Street including but not limited to:

- Record the existing elevations and locations of the stairs and decks for each entrance prior to removal
- Remove and dispose of all existing deck structure, footings, stairs and decking
- Supply and install all material needed to construct new footings, structure, stairs, railings, stringer pads, lattice decking and privacy partitions for each new deck as detailed in the contract drawings.
- Topsoil and hand seed all disturbed areas adjacent to the construction.
- Placement of concrete extensions for existing sidewalk adjacent to the structures. This shall be required at the vast majority of the structures to ensure that the new decks can be affixed to the sidewalk. It shall be assumed by the Contractor that all Style #3 deck structures shall require sidewalk extensions approximately 250 to 300 mm in length. No additional payment shall be made for varying length of sidewalk extensions required to complete the Contract. Concrete sidewalk is to be 125mm thick. To be included in this item is the supply, placement and compaction of Granular A, 100mm in depth as required and compacted, below the new sidewalk sections. The contract

price for the above item shall also include the reinstatement of adjacent surface materials behind sidewalks that may include but are not limited to earth and grass. Placement of adjacent materials shall be equal to or better than original conditions. The construction of sidewalk shall conform to OPSS 351. Transitions from new sidewalk to existing or undisturbed areas will be field fit to provide positive drainage and a smooth grade transition. These transitions to existing undisturbed areas and/or right-of-way shall be a gentle slope with all steep grades minimized where possible. The production of concrete material for sidewalks shall conform to Section 9.3 of the Ontario Building Code (Latest Edition). The concrete mix shall conform to the criteria stated in the Ontario Building Code (Latest Edition). Sidewalk sections at driveway entrances are to be completed in accordance with OPSD 310.050. All poured concrete is to be properly protected during curing to ensure that the surface is not disturbed by weather or others.

The Contractor will ensure that each residence will always have at least one fully complete entrance during construction (i.e. front entrances and rear entrances for the same residence cannot be simultaneously under construction). Prior to removal of each structure, the Contractor shall provide notice to the affected resident(s). The Contractor shall be responsible for managing resident complaints and conflicts in a positive manner throughout the duration of construction.

The Contractor must provide and maintain signage which clearly details that the affected decks are under construction and not to be used as entrances or egress while under construction.

The Contractor will need to effectively support the gas meters which are affixed to some of the decks during construction to the satisfaction of the utility company and the contract administrator.

All inspections required by the City of Kingston are to be coordinated by the Contractor.

Residents shall be notified as specified in the contract documents.

Granular material required for the installation of the stringer support pads shall be 19mm crushed stone.

The Contractor will ensure that the entrances/decks are not used in any capacity by the residents after construction on that entrance/deck has begun until they are fully completed.

The Contractor shall be responsible for providing a temporary access in the event that the unit only has one entrance deck. Construction shall be staged such that interruptions in accessing the units are minimal.

Payment for any deck will only be processed when the deck is deemed by the Owner or Owner's Representative to be complete.

In the scope of this contract, a single Style #3 deck shall be considered to include the entire structure servicing the two units. Hence, there are six (6) Style #3 structures servicing twelve (12) units.

All construction shall conform to the OBC (Latest Edition), the City of Kingston standards and the contract drawings. The Contractor is required to provide themselves with the most recent copy of OBC and the City of Kingston's standards. This item includes mobilization and demobilization and all costs with the removal of existing decks as well and the reconstruction of the new decks.

**Basis of Payment:** Payment at the contract price for the above tender items shall be full compensation for all labour, equipment and material required to do the work. Measurement for payment is by each completed deck.

**END OF SECTION**





---

**WORK PERFORMANCE REFERENCE**

**NOTE:**

- (1) Reference must be from persons or companies for whom you have performed work within the last twenty-four (24) months. Also reference must be for work of the same nature as that called for in the contract.
- (2) If you have performed work for Kingston & Frontenac Housing Corporation or Town Homes Kingston within the past forty-eight months please use them as one of your references. Failure to do so may be cause for disqualification.

1. Name: \_\_\_\_\_  
Address: \_\_\_\_\_  
Telephone: \_\_\_\_\_

2. Name: \_\_\_\_\_  
Address: \_\_\_\_\_  
Telephone: \_\_\_\_\_

3. **BANK REFERENCE**

Name of Branch: \_\_\_\_\_  
Address: \_\_\_\_\_  
Telephone: \_\_\_\_\_

**FIRM:** \_\_\_\_\_

**ADDRESS:** \_\_\_\_\_

**TELEPHONE:** \_\_\_\_\_

\_\_\_\_\_  
**Date**

\_\_\_\_\_  
**Signature**



## **Contract Drawings**

The following is a list of drawings pertinent to Contract THK PT 19-03. The Contractor is responsible for ensuring that all drawings have been received and reviewed prior to bidding.

### List of Drawings

S1 – Decks at Main Entrance

S2 – Decks at Main and Rear Entrance

A-1 – Site Plan



- NOTES:
- ALL WORK SHALL BE IN ACCORDANCE WITH RELEVANT CODES AND GUIDELINES INCLUDING THE ONTARIO BUILDING CODE.
  - ALL DRAWINGS AND ADDENDA ARE TO BE READ AS, AND IN CONJUNCTION WITH THE SPECIFICATIONS.
  - ALL EQUIPMENT SHALL BE INSTALLED AS SPECIFIED OR APPROVED EQUIVALENT.
  - CONTRACTOR MUST CHECK AND VERIFY ALL DIMENSIONS BEFORE PROCEEDING WITH WORK AND BE RESPONSIBLE FOR SAME.
  - CONTRACTOR MUST REPORT ANY DISCREPANCIES TO ENGINEER FOR RESOLUTION BEFORE COMMENCING THE WORK.
  - ANY CHANGES MUST BE APPROVED BY THE ENGINEER.

- (A) A DETAIL NO.  
(B) B DRAWING NO. - WHERE DETAILED

- NOTES:
- ALL LUMBER TO BE GRADE SPF No. 1/2 OR BETTER AND IS TO BE PRESSURE TREATED, INCLUDING CUT ENDS, IN ACCORDANCE WITH CSA 080 FOR THE FOLLOWING USE CATEGORIES:  
1.1. POST: CATEGORY UC4  
1.2. JOISTS, BEAMS, DECK BOARDS, AND RAILING COMPONENTS: CATEGORY UC3
  - ALL NAILS TO BE GALVANIZED SPIRAL NAILS LENGTHS TO ASSURE A SECURE CONNECTIONS WITH A MINIMUM EMBEDMENT DEPTH OF 38MM.
  - SCREWS, MACHINE BOLTS, NUTS, AND WASHERS TO BE ZINC PLATED UNLESS OTHERWISE NOTED.
  - SCREWS TO BE EMBEDDED TO A MINIMUM DEPTH OF 38MM.
  - NO SCREWS TO BE USED FOR FRAMING OR THE INSTALLATION OF HANGERS.
  - ALL DECKING TO BE STAINED WITH TWO COATS NATURAL COLOUR STAIN.
  - TOP STEPS AND ALL TREADS TO BE PAINTED WITH NON-SLIP PROTECTIVE COATING.
  - ALL PRESSURE TREATED MEMBER CUTS ARE TO BE TREATED UPON ERECTION.
  - CONTRACTOR IS RESPONSIBLE FOR CONFIRMING ALL DIMENSIONS AND ESTABLISHING ELEVATIONS ON SITE PRIOR TO CONSTRUCTION OF STAIRS.
  - ANY DISCREPANCIES BETWEEN THE DRAWINGS AND SITE CONDITIONS ARE TO BE REPORTED TO THE ENGINEER PRIOR TO COMMENCEMENT OF STAIR CONSTRUCTION.
  - ALL RISERS OF THE SAME STAIRCASE SHALL BE EQUAL HEIGHT.
  - GUARDS ON LANDINGS AND PLATFORMS TO BE FABRICATED TO MEET REQUIREMENTS OF THIS DESIGN AND BE IN ACCORDANCE WITH SECTION 3.4.6.6 AND 3.3.1.17 OF THE ONTARIO BUILDING CODE, LATEST EDITION.
  - FOR GUARD / RAIL CONSTRUCTION, USE DETAIL EC-1 OF SB-7 SUPPLEMENTARY STANDARD FROM ONTARIO BUILDING CODE, LATEST EDITION.
  - STAIRS TO BE FABRICATED TO MEET THE REQUIREMENTS OF THIS DESIGN AND IN ACCORDANCE WITH SECTION 3.4.6.8 OF THE ONTARIO BUILDING CODE, LATEST EDITION.
  - STAIRS AND LANDINGS HAVE BEEN DESIGNED IN ACCORDANCE WITH THE LOADING REQUIREMENTS OF 4.1.5.3 AND 9.4.2.3 THE ONTARIO BUILDING CODE, LATEST EDITION.

01	ISSUED FOR TENDER	30.01.2015
REVISION	DESCRIPTION	DD.MM.YYYY

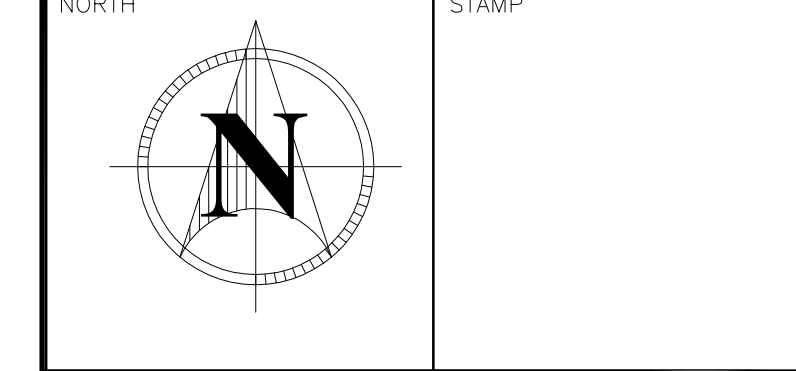

PROJECT  
**PATRICK STREET HOUSING DEVELOPMENT  
80 UNITS N.P. HOUSING  
KINGSTON, ONTARIO**

TOWNHOMES KINGSTON  
KINGSTON, ONTARIO

DRAWING TITLE

**DECKS AT MAIN  
ENTRANCE**

DESIGNED BY  
**A. SIMMONS**

DRAWN BY  
**M. ROWSELL**

REVIEWED BY  
**A. SIMMONS**

APPROVED BY  
**A. SIMMONS**

PROJECT DATE  
**22/12/2014** (DD/MM/YYYY)

PROJECT # **1453010** DRAWING SCALE **AS NOTED**

DRAWING # **S-1**

**CONTRACTOR MUST CHECK AND VERIFY ALL DIMENSIONS BEFORE PROCEEDING WITH WORK**

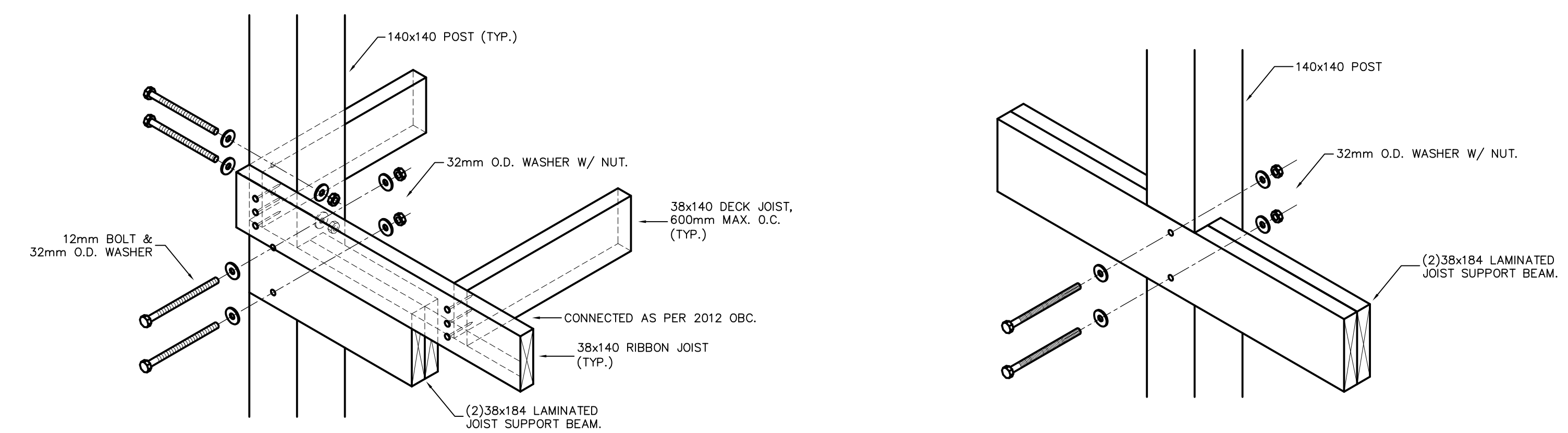

**7 DECK FASTENING DETAILS - (EXCEPT REAR DECKS)**  
SCALE: NTS

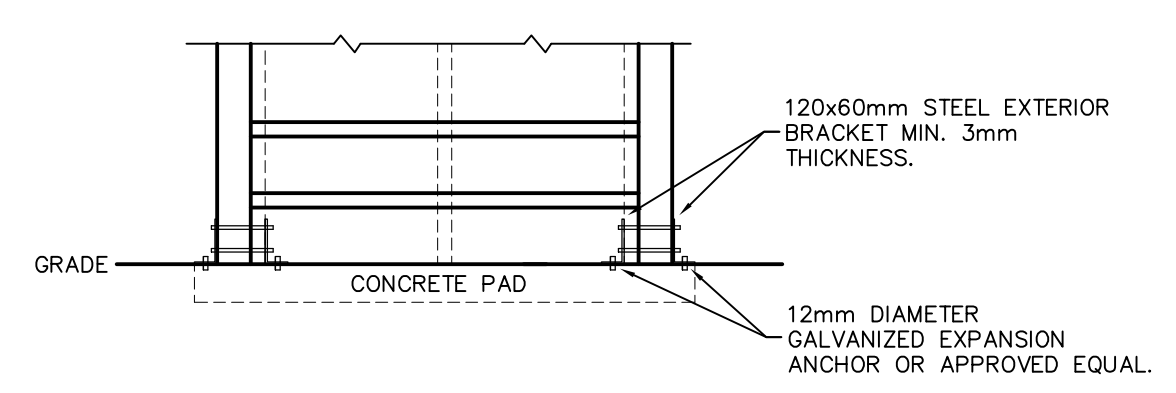

**5 FRONT VIEW STRINGER**  
SCALE: NTS

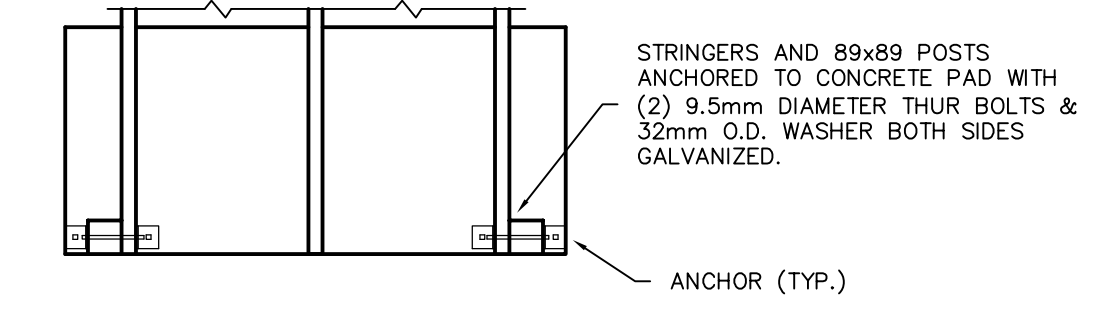

**6 PLAN VIEW STRINGER**  
SCALE: NTS

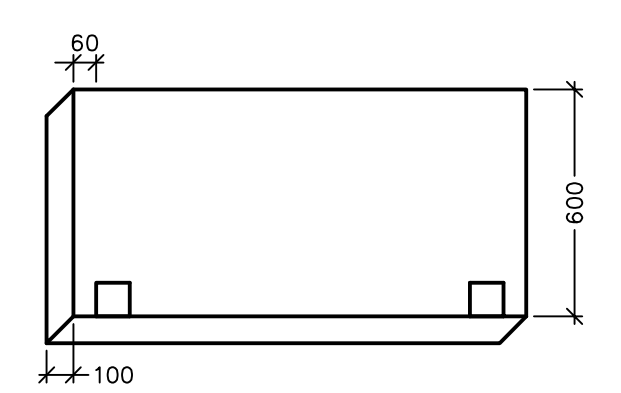

**4 TYPICAL CONCRETE PAD DETAIL**  
SCALE: NTS

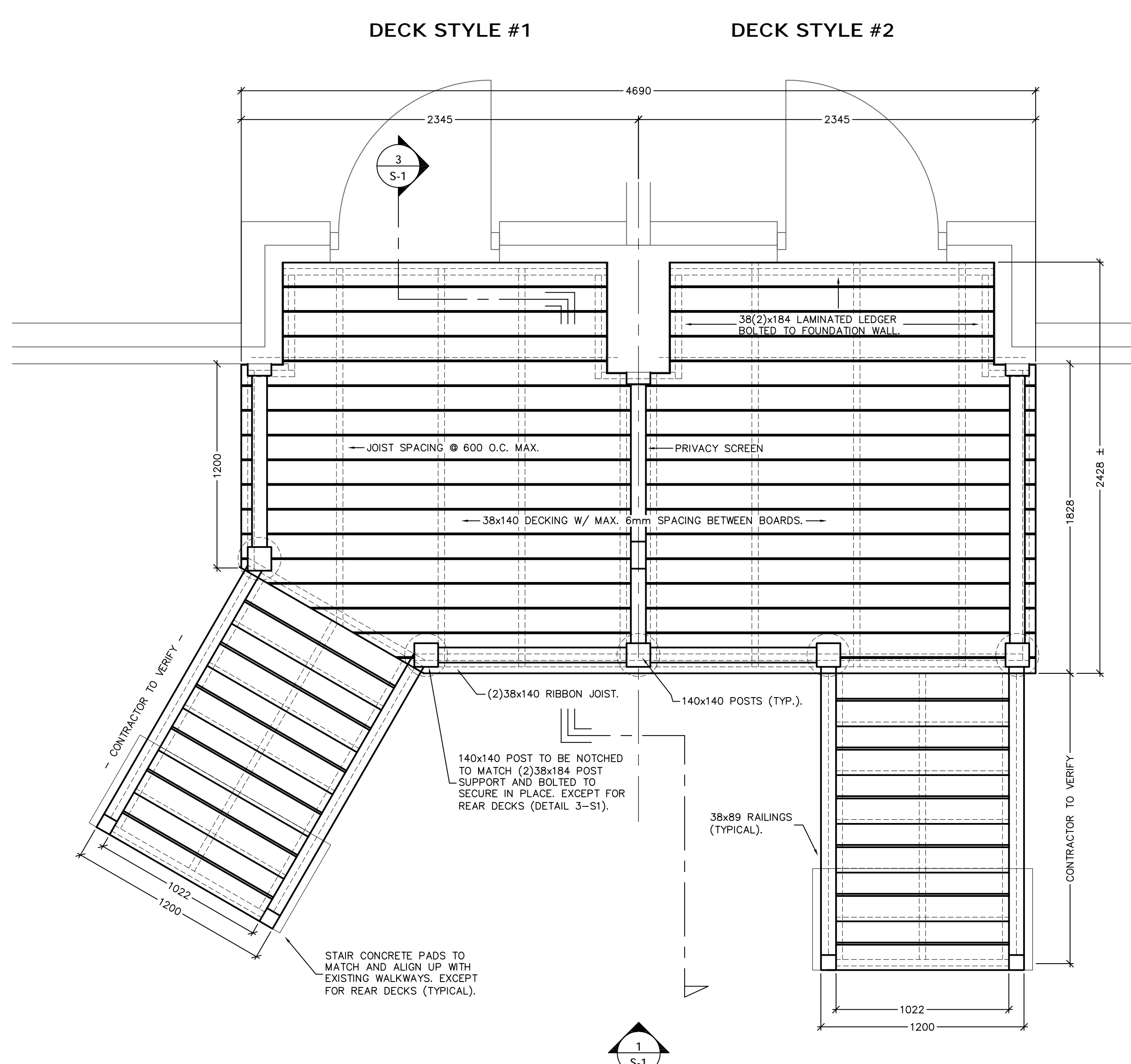

**2 DECK PLAN - STYLE #1 AND #2**  
SCALE: 1:20

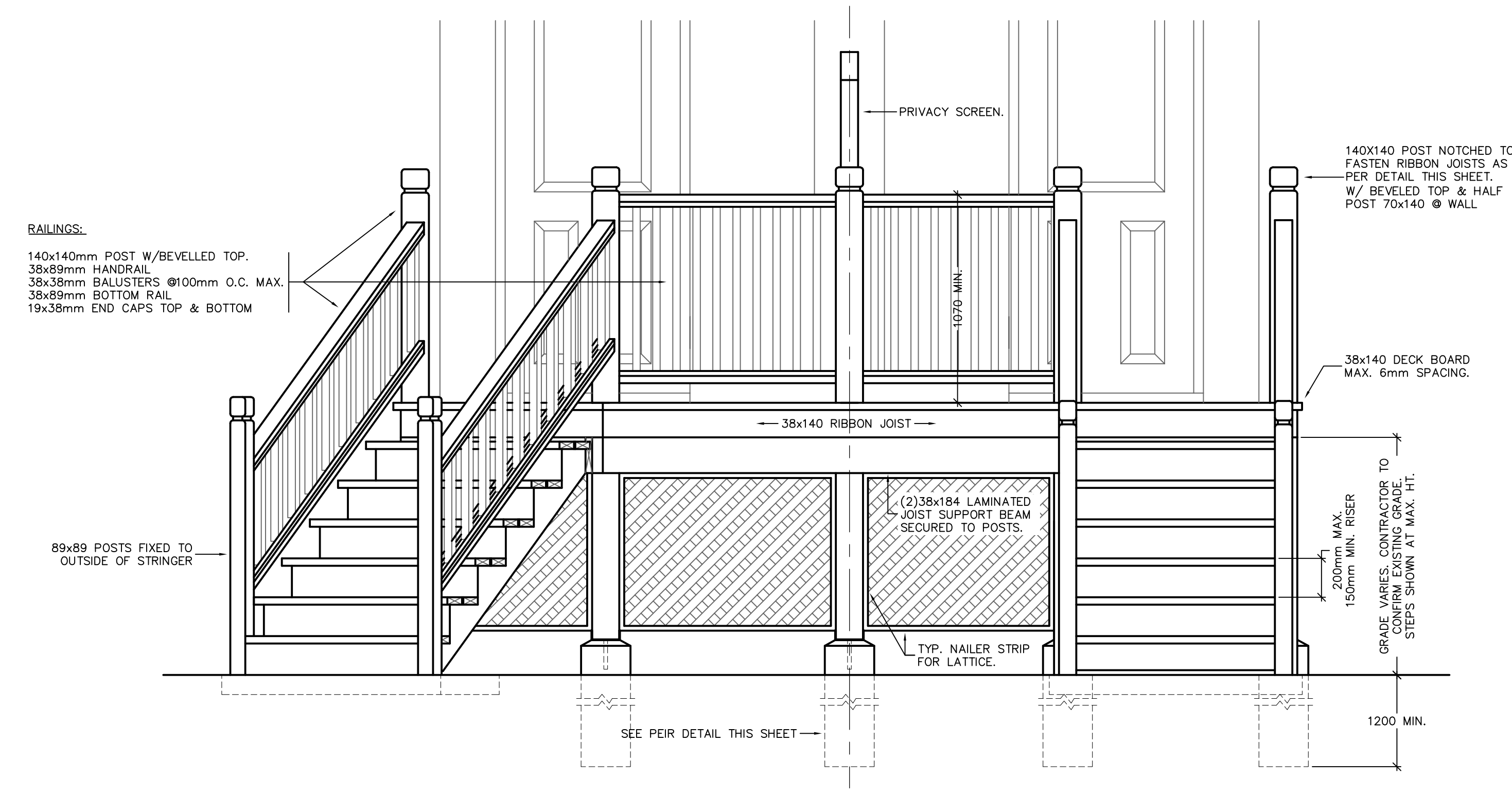

**1 TYPICAL ELEVATION - DECK STYLE #1 AND #2**  
SCALE: 1:20

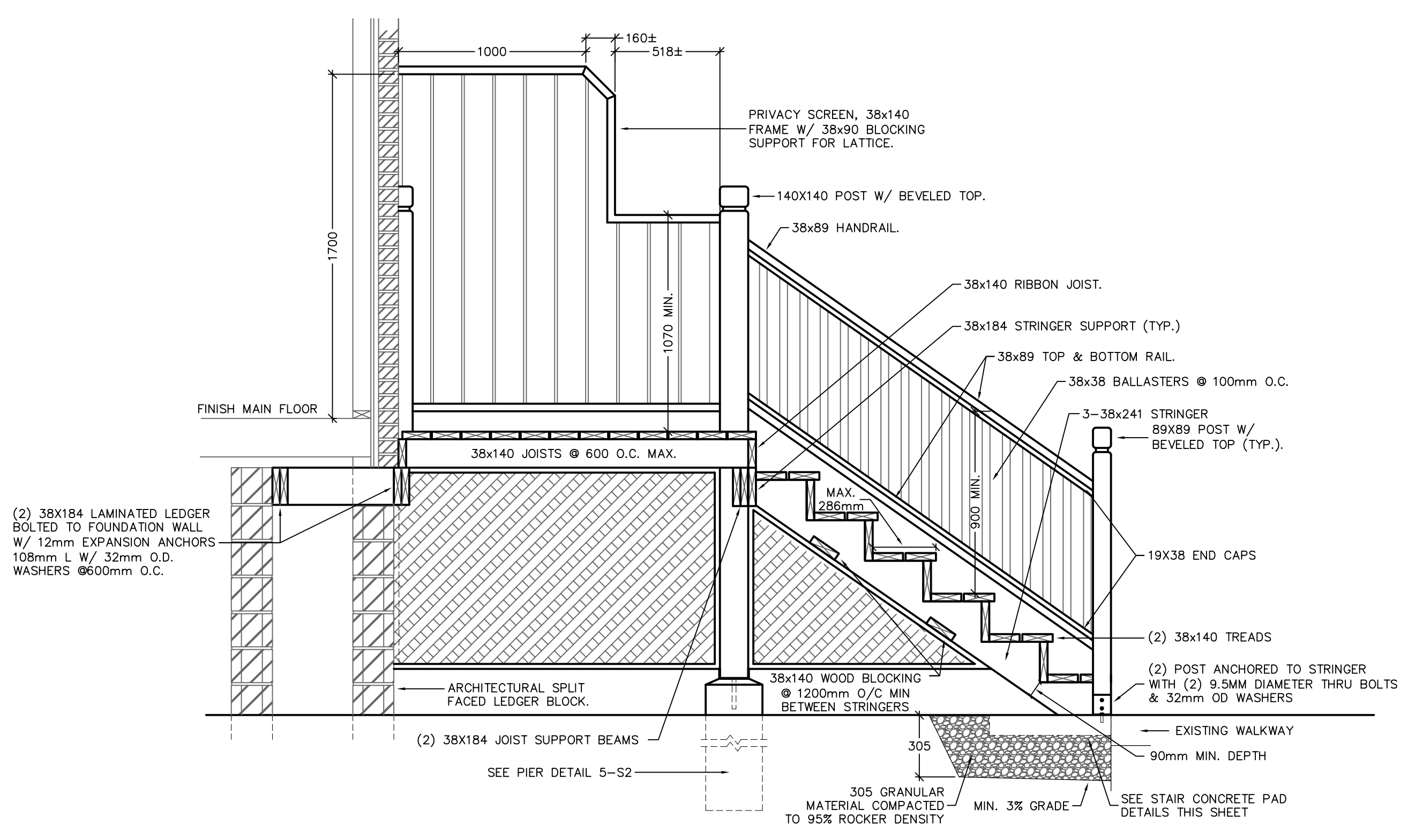

**3 SECTION -**  
SCALE: 1:20

CAD OPERATOR: Mike Rowse  
CAD FILE: P:\3000 - Structural\1453010 - Exterior Stair Replacement (Town Homes - Kingston)\Drawings\1453010-STRUC-1-10.dwg  
PLOT SCALE: 1:20  
DATE PLOTTED: 2014-12-10  
GSG-ARCH.D



DECK STYLE #3

DECK STYLE #3

DECK STYLE #4

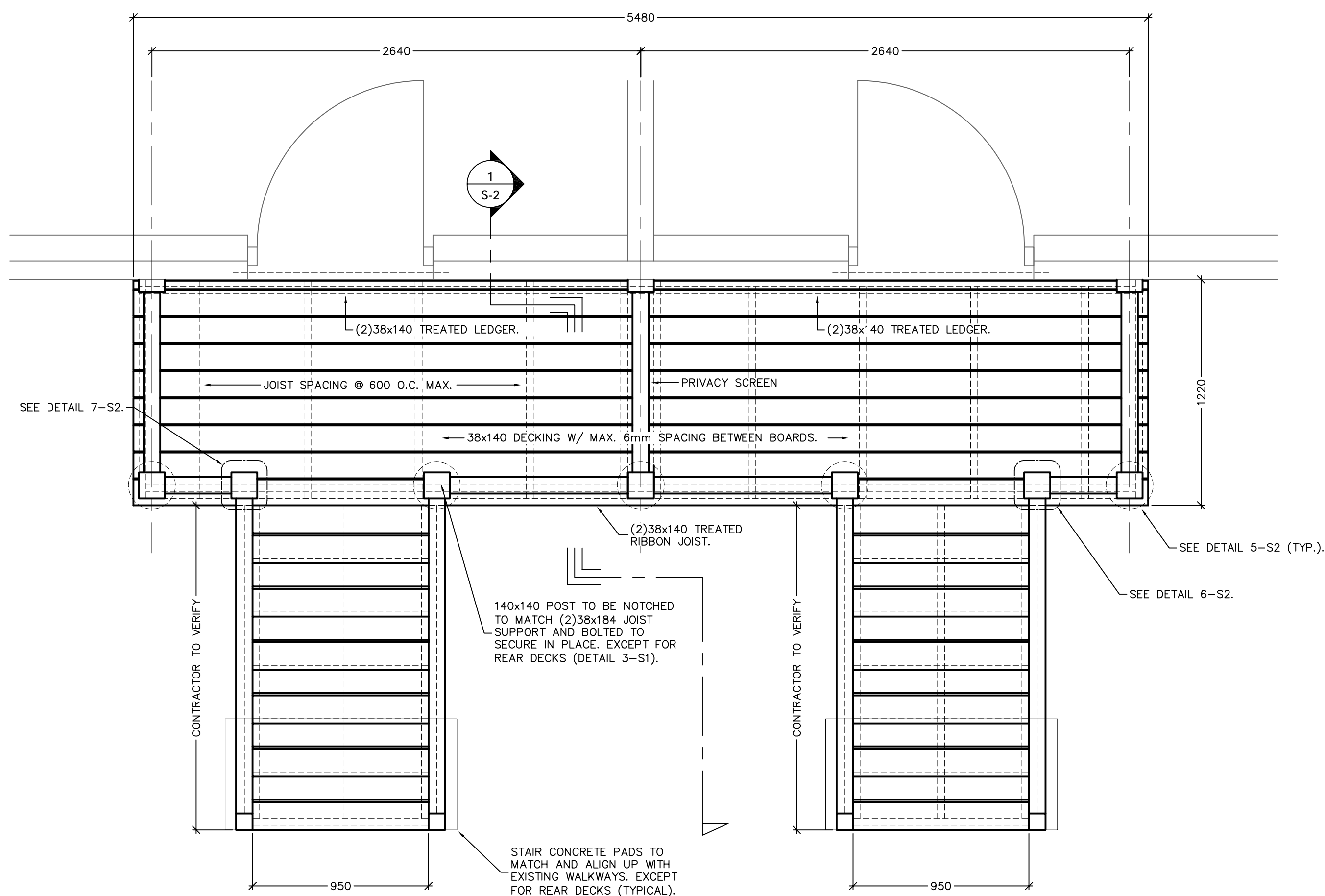

2 DECK PLAN (FRONT) - DECK STYLE #3  
SCALE: 1:20

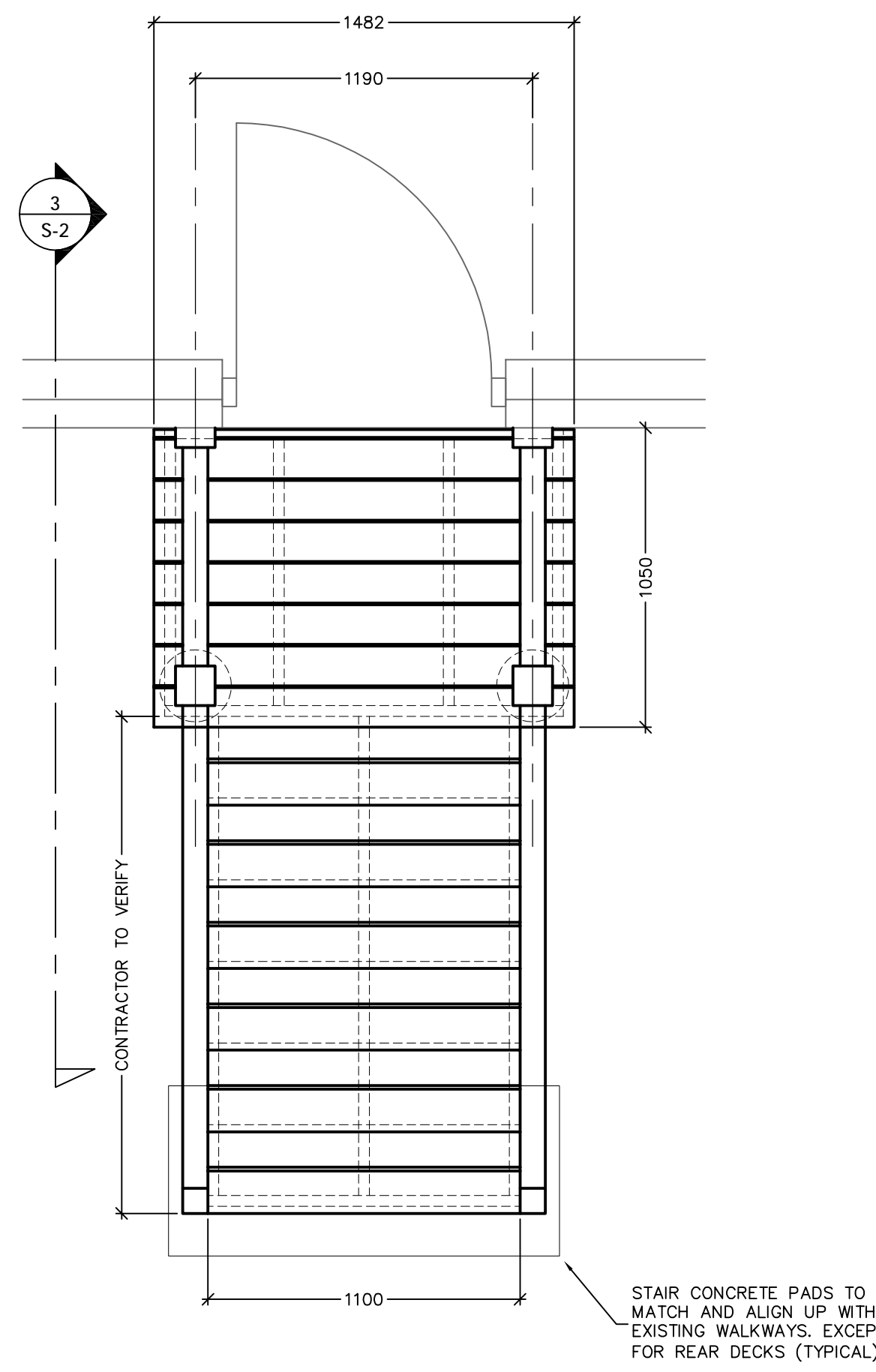

4 DECK PLAN (REAR) - DECK STYLE #4  
SCALE: 1:20

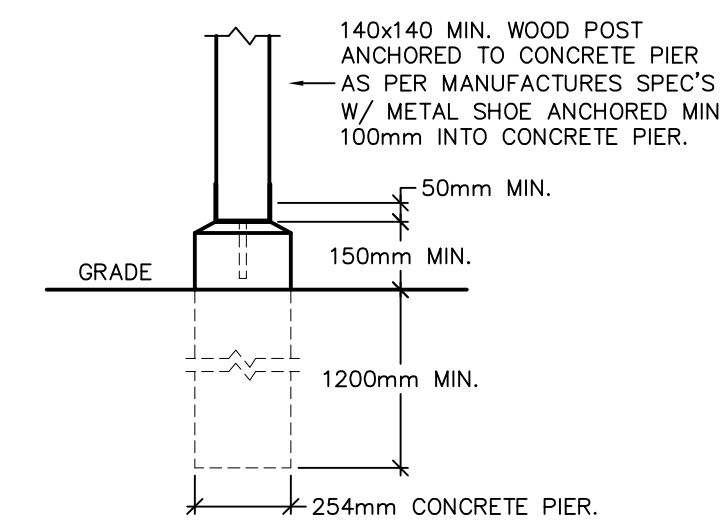

5 TYPICAL PIER DETAIL  
SCALE: NTS

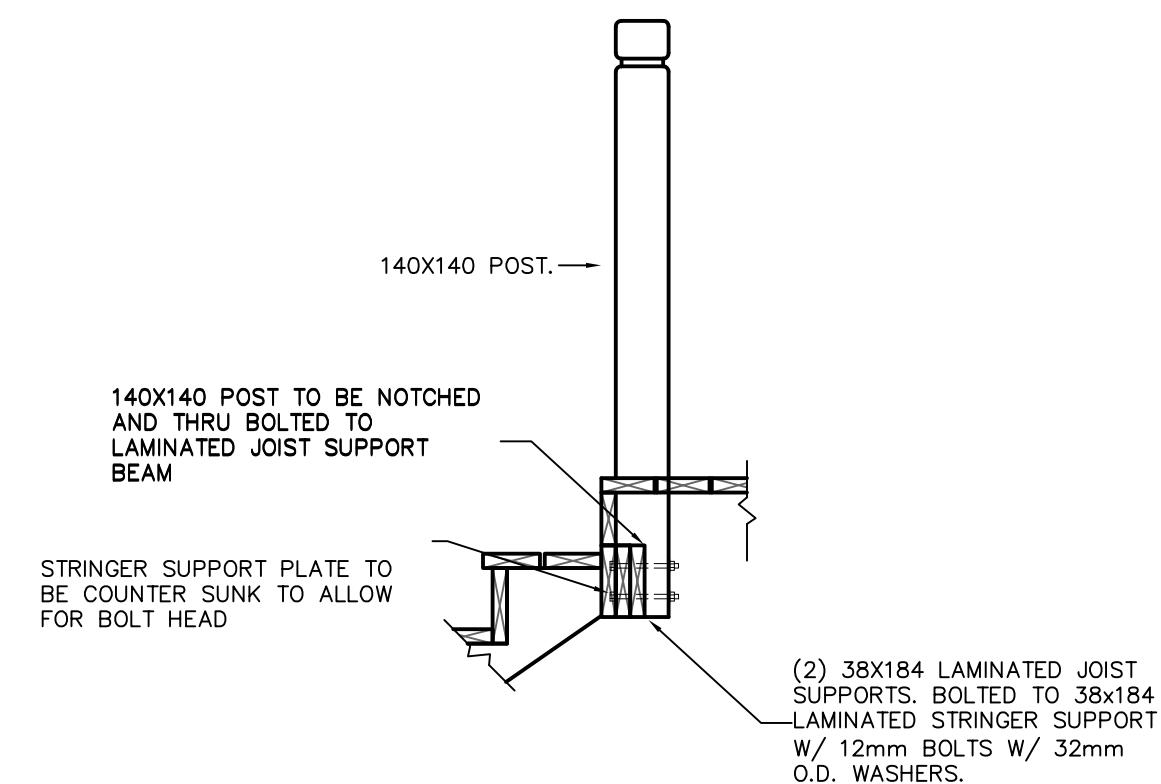

6 DETAIL 'B'  
SCALE: NTS

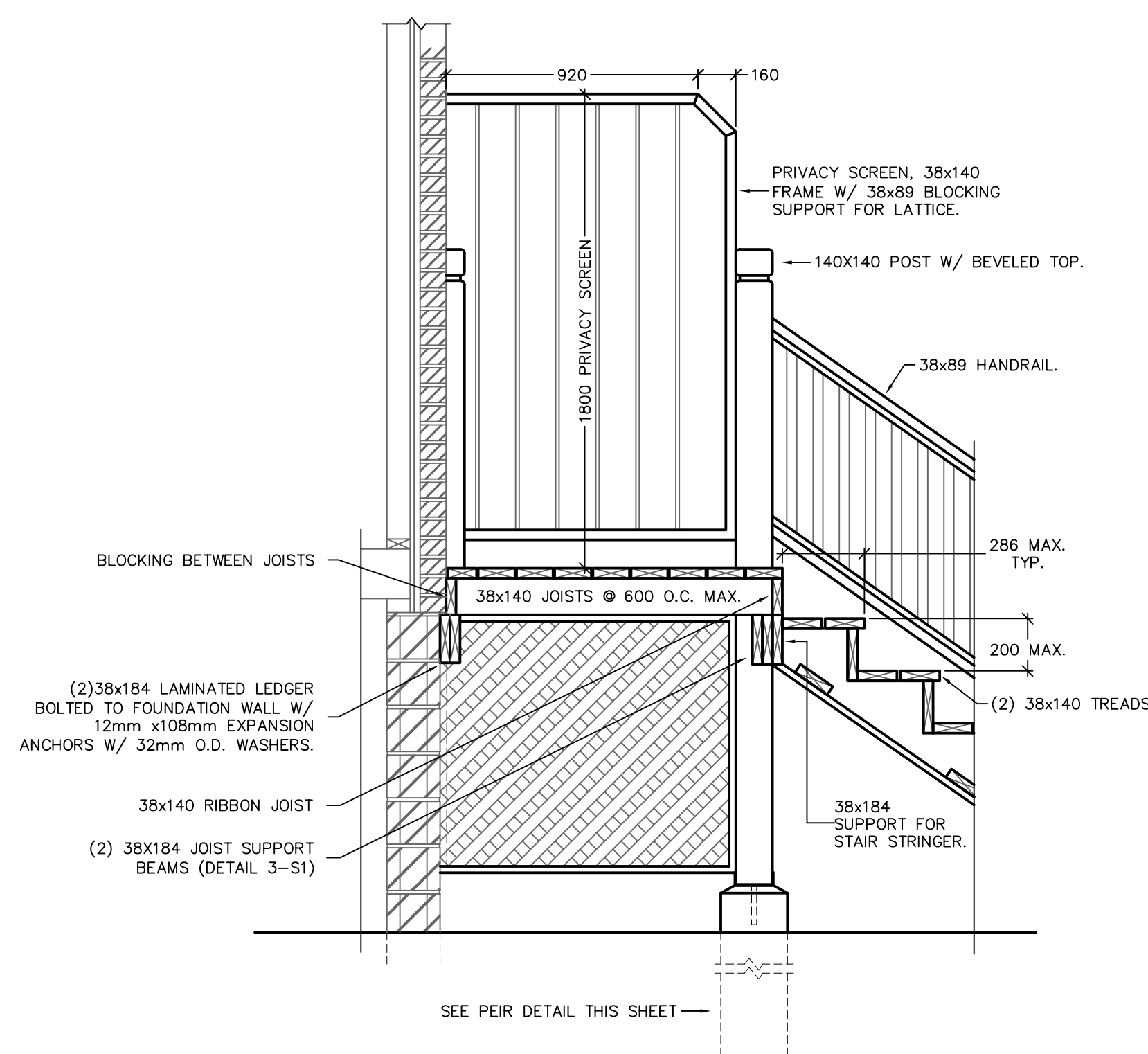

1 SECTION - DECK STYLE #3  
SCALE: 1:20

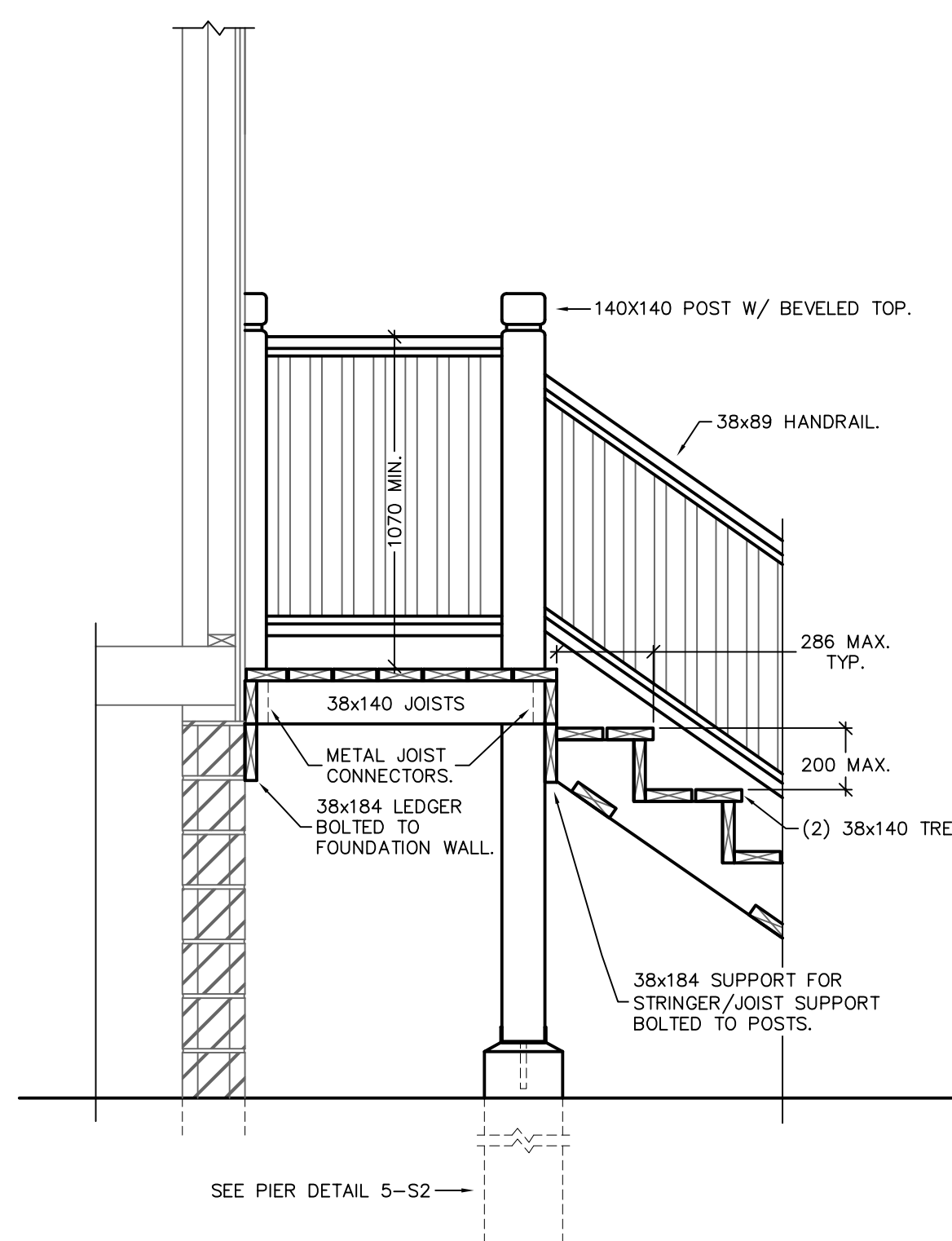

3 SECTION - DECK STYLE #4  
SCALE: 1:20

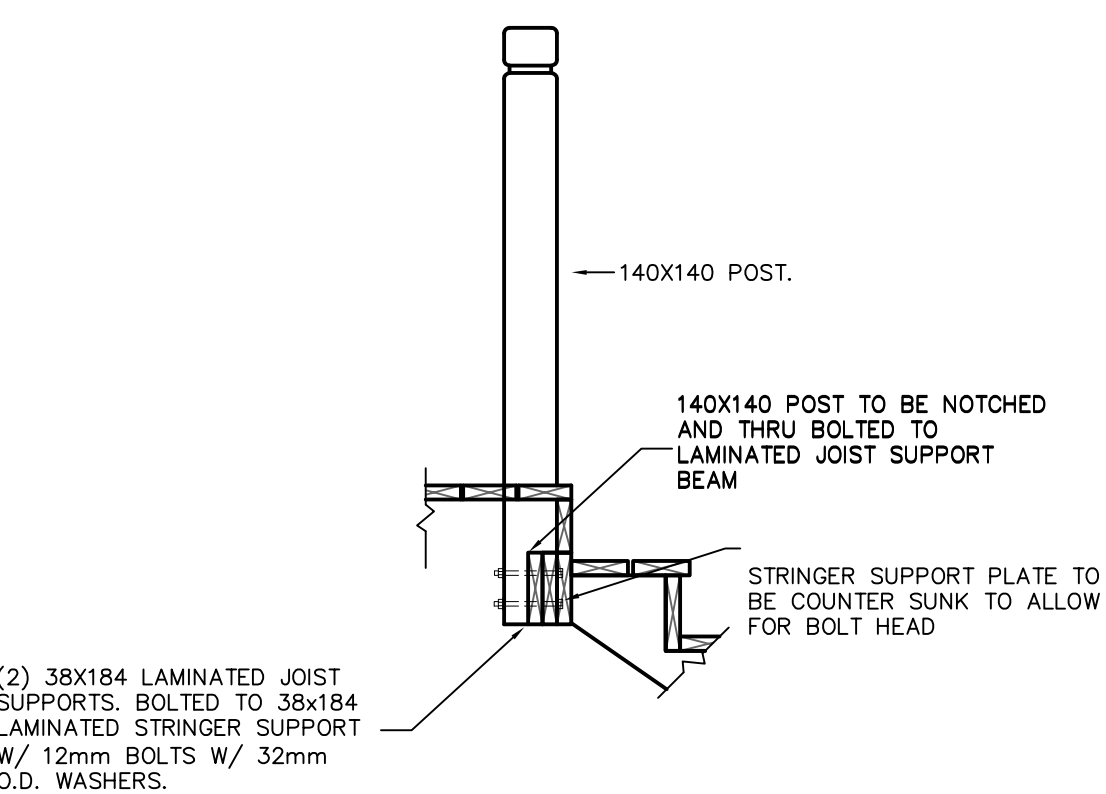

7 DETAIL 'A'  
SCALE: NTS

- NOTES:
- ALL WORK SHALL BE IN ACCORDANCE WITH RELEVANT CODES AND GUIDELINES INCLUDING THE ONTARIO BUILDING CODE.
  - ALL DRAWINGS AND ADDENDA ARE TO BE READ AS, AND IN CONJUNCTION WITH THE SPECIFICATIONS.
  - ALL EQUIPMENT SHALL BE INSTALLED AS SPECIFIED OR APPROVED EQUIVALENT.
  - CONTRACTOR MUST CHECK AND VERIFY ALL DIMENSIONS BEFORE PROCEEDING WITH WORK AND BE RESPONSIBLE FOR SAME.
  - CONTRACTOR MUST REPORT ANY DISCREPANCIES TO ENGINEER FOR RESOLUTION BEFORE COMMENCING THE WORK.
  - ANY CHANGES MUST BE APPROVED BY THE ENGINEER.

- (A) A DETAIL NO.  
(B) B DRAWING NO. - WHERE DETAILED

- NOTES:
- ALL LUMBER TO BE GRADE SPF No. 1/2 OR BETTER AND IS TO BE PRESSURE TREATED, INCLUDING CUT ENDS, IN ACCORDANCE WITH CSA 080 FOR THE FOLLOWING USE CATEGORIES:  
1.1. POST: CATEGORY UC4  
1.2. JOISTS, BEAMS, DECK BOARDS, AND RAILING COMPONENTS: CATEGORY UC3
  - ALL NAILS TO BE GALVANIZED SPIRAL NAILS LENGTHS TO ASSURE A SECURE CONNECTIONS WITH A MINIMUM EMBEDMENT DEPTH OF 38MM.
  - SCREWS, MACHINE BOLTS, NUTS, AND WASHERS TO BE ZINC PLATED UNLESS OTHERWISE NOTED.
  - SCREWS TO BE EMBEDDED TO A MINIMUM DEPTH OF 38MM.
  - NO SCREWS TO BE USED FOR FRAMING OR THE INSTALLATION OF HANGERS.
  - ALL DECKING TO BE STAINED WITH TWO COATS NATURAL COLOUR STAIN.
  - TOP STEPS AND ALL TREADS TO BE PAINTED WITH NON-SLIP PROTECTIVE COATING.
  - ALL PRESSURE TREATED MEMBER CUTS ARE TO BE TREATED UPON ERECTION.
  - CONTRACTOR IS RESPONSIBLE FOR CONFIRMING ALL DIMENSIONS AND ESTABLISHING ELEVATIONS ON SITE PRIOR TO CONSTRUCTION OF STAIRS.
  - ANY DISCREPANCIES BETWEEN THE DRAWINGS AND SITE CONDITIONS ARE TO BE REPORTED TO THE ENGINEER PRIOR TO COMMENCEMENT OF STAIR CONSTRUCTION.
  - ALL RISERS OF THE SAME STAIRCASE SHALL BE EQUAL HEIGHT.
  - GUARDS ON LANDINGS AND PLATFORMS TO BE FABRICATED TO MEET REQUIREMENTS OF THIS DESIGN AND BE IN ACCORDANCE WITH SECTION 3.4.6.6 AND 3.3.1.17 OF THE ONTARIO BUILDING CODE, LATEST EDITION.
  - FOR GUARD / RAIL CONSTRUCTION, USE DETAIL EC-1 OF SB-7 SUPPLEMENTARY STANDARD FROM ONTARIO BUILDING CODE, LATEST EDITION.
  - STAIRS TO BE FABRICATED TO MEET THE REQUIREMENTS OF THIS DESIGN AND IN ACCORDANCE WITH SECTION 3.4.6.8 OF THE ONTARIO BUILDING CODE, LATEST EDITION.
  - STAIRS AND LANDINGS HAVE BEEN DESIGNED IN ACCORDANCE WITH THE LOADING REQUIREMENTS OF 4.1.5.3 AND 9.4.2.3 OF THE ONTARIO BUILDING CODE, LATEST EDITION.

01	ISSUED FOR TENDER	30.01.2015
REVISION	DESCRIPTION	DD.MM.YYYY

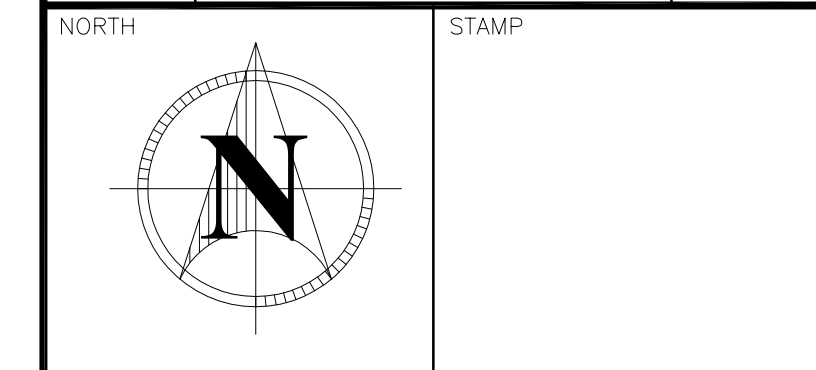

PROJECT  
**PATRICK STREET  
HOUSING DEVELOPMENT  
80 UNITS N.P. HOUSING  
KINGSTON, ONTARIO**

TOWNHOMES KINGSTON  
KINGSTON, ONTARIO

DRAWING TITLE  
**DECKS AT MAIN &  
REAR ENTRANCE**

DESIGNED BY  
**A. SIMMONS**

DRAWN BY  
**M. ROWSELL**

REVIEWED BY  
**A. SIMMONS**

APPROVED BY  
**A. SIMMONS**

PROJECT DATE  
**22/12/2014** (DD/MM/YYYY)

PROJECT # **1453010** DRAWING SCALE **AS NOTED**

DRAWING # **S-2**

CONTRACTOR MUST CHECK AND VERIFY ALL DIMENSIONS BEFORE PROCEEDING WITH WORK

CAD OPERATOR: Mica Rowse  
CAD FILE: P:\3000 - Structural\1453010 - Structure\1453010-STRUC2-10.dwg  
PLOT SCALE: 1:20  
DATE PLOTTED: 2014-12-10  
GGS-ARCH.D





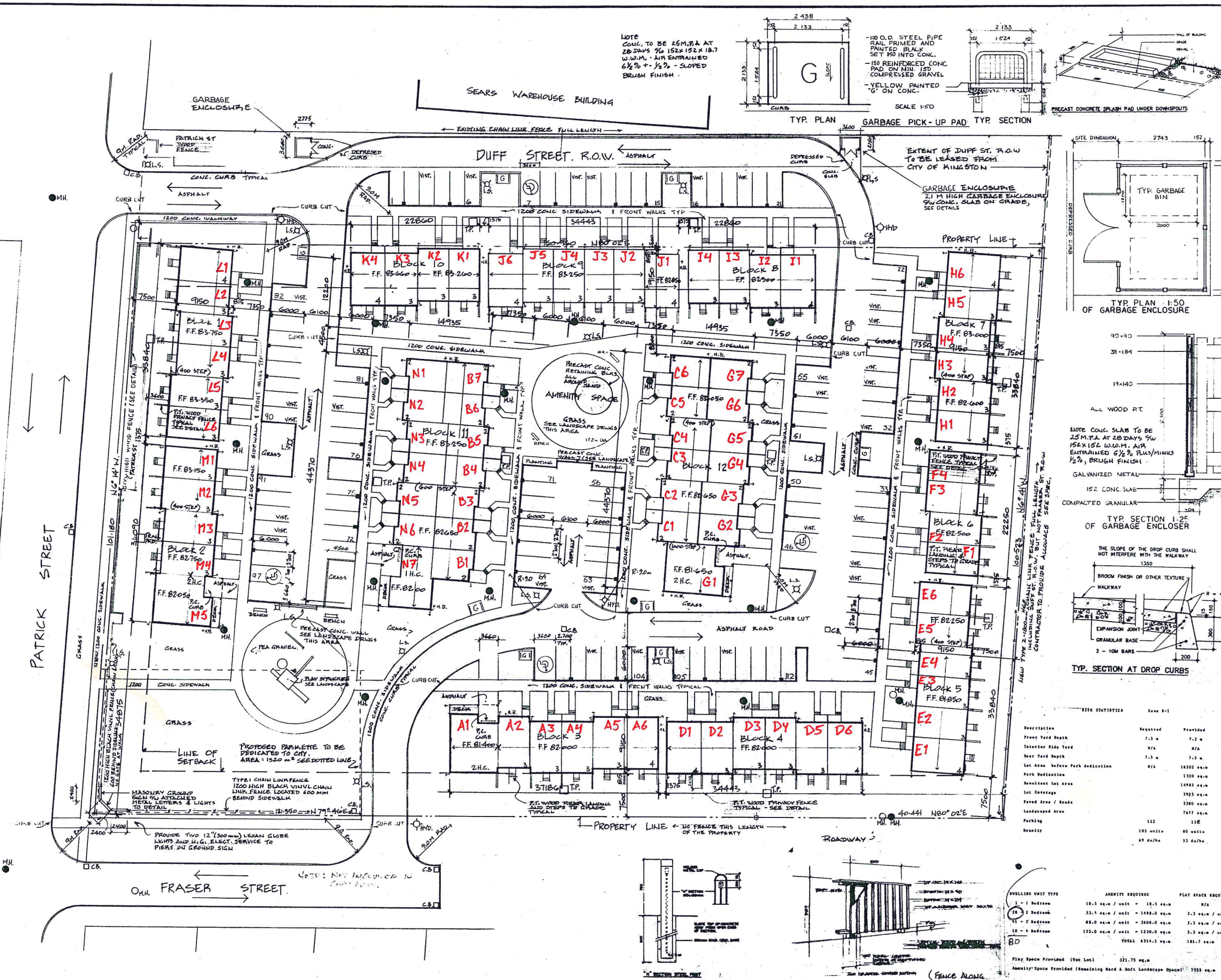

NOTE  
CONC. TO BE 25M.P.A. AT  
20 DAYS 9% 15X15X18.75  
W.W.M. AIR ENTRAINED  
6 1/2% + 1/2% - SLOPED  
BRUSH FINISH.

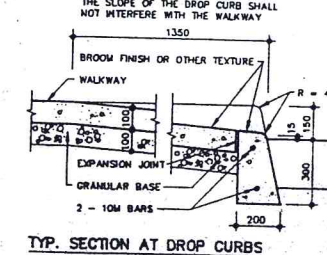
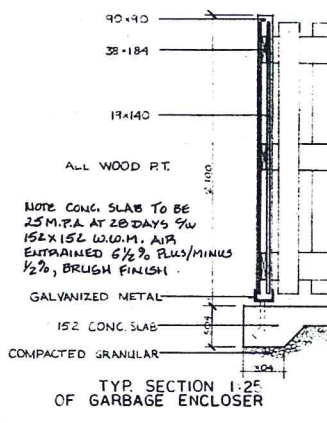
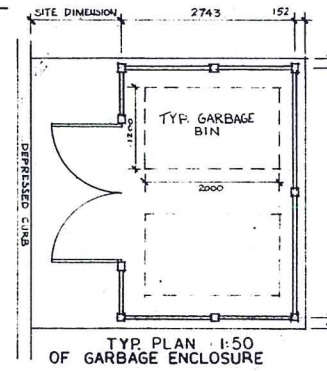
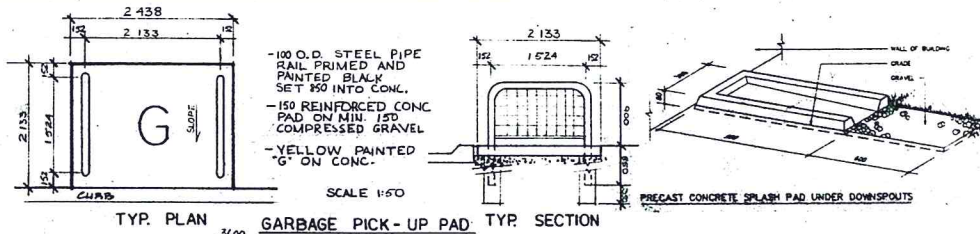

SITE STATISTICS Zone S-1

Description	Required	Provided
Front Yard Depth	7.5 m	7.5 m
Interior Side Yard	N/A	N/A
Rear Yard Depth	7.5 m	7.5 m
Lot Area before Park Deduction	N/A	16202 sq.m
Park Deduction		1320 sq.m
Resultant Lot Area		14882 sq.m
Lot Coverage		3925 sq.m
Paved Area + Roads		3280 sq.m
Landscape Area		7877 sq.m
Parking	112	112
Density	103 units	80 units
	89 du/ha	53 du/ha

RESIDING UNIT TYPE

Unit Type	Area (sq.m)	Volume (cu.m)	Play Space (sq.m)
1 - 1 Bedroom	18.3 sq.m / unit	18.3 cu.m	N/A
10 - 2 Bedroom	53.4 sq.m / unit	1498.0 cu.m	2.3 sq.m / unit
11 - 3 Bedroom	48.0 sq.m / unit	3608.0 cu.m	2.3 sq.m / unit
10 - 4 Bedroom	123.0 sq.m / unit	1230.0 cu.m	2.3 sq.m / unit
<b>TOTAL</b>	<b>4314.3 sq.m</b>	<b>181.7 cu.m</b>	

Play Space Provided (Tot Lot) 321.75 sq.m  
 Amenity Space Provided (Remaining Hard & Soft Landscape Space) 7335 sq.m

**NOTES**  
 PLAN BASED ON INFORMATION PROVIDED BY GRANITE ELLIOT LTD. O.L.S. 152 W.W.M. AIR ENTRAINED 6 1/2% + 1/2% - SLOPED BRUSH FINISH. REG. PLAN NO. G-22 CITY OF KINGSTON

**LEGEND:**  
 X.L.S. - LIGHT STANDARD  
 □ T.P. - TRANSFORMED PAD  
 ○ F.H.D. - FIRE HYDRANT  
 ● M.H. - SAN. MANHOLE  
 ○ M.H. - STORM MANHOLE  
 ○ C.B. - CATCHBASIN  
 ■ - BLOCK HEATER RECEPTACLES  
 → - RAIN WATER LEADER 2" CONC. SPLASH PADS.  
 ○ - HANDICAPPED SYMBOL PAINTED ON ASPHALT - SEE DETAIL  
 45 - PARKING STALL NUMBER PAINTED ON ASPHALT - SEE DETAIL  
 163 - GARBAGE PICK-UP PAD - SEE DETAIL  
 - PRE-CAST CONC. CURB (2450 LxW) AT H/C

GARBAGE PICK-UP TO BE BY CITY (CURB SIDE) PERIODIC DELIVERY TO BE BY GROUPED BOXES, INSTALLATION AND LOCATION BY CANADA TEST

**REVISIONS / PRINTS**

NO.	DESCRIPTION	DATE
3	ISSUE FOR TENDER	JULY 25/90
2	SITE PLAN APPLICATION	JUNE 28/90
1	GENERAL REVISION	JULY 4/90

**NOTE:**  
 DRAWINGS MUST NOT BE SCALED. Contractor shall verify and be responsible for all dimensions, and shall report any discrepancy to the Architect before proceeding with any work. Drawings not to be used for construction unless signed by the Architect.

**Robert J. Crothers Architect**  
 152A - 2 Catherine Street Kingston, Ont. K7M 1Z7 (613) 548-0736 Fax: 548-6485

**PROJECT:**  
 PATRICK STREET HOUSING DEVELOPMENT  
 Townhomes Kingston  
 80 Unit Non Profit Housing Kingston, Ontario

**TITLE:**  
 SITE PLAN

**PROJECT No. 4389 SHEET No.**  
 DATE: JULY 19 1990  
 SCALE: 1:300  
 DRAWN: W.H.  
 CHECKED: R.C.

**A-1**  
 63