

PRODUCT CATALOG

LOW VOLTAGE : IE3 - 3 PHASE INDUCTION MOTOR

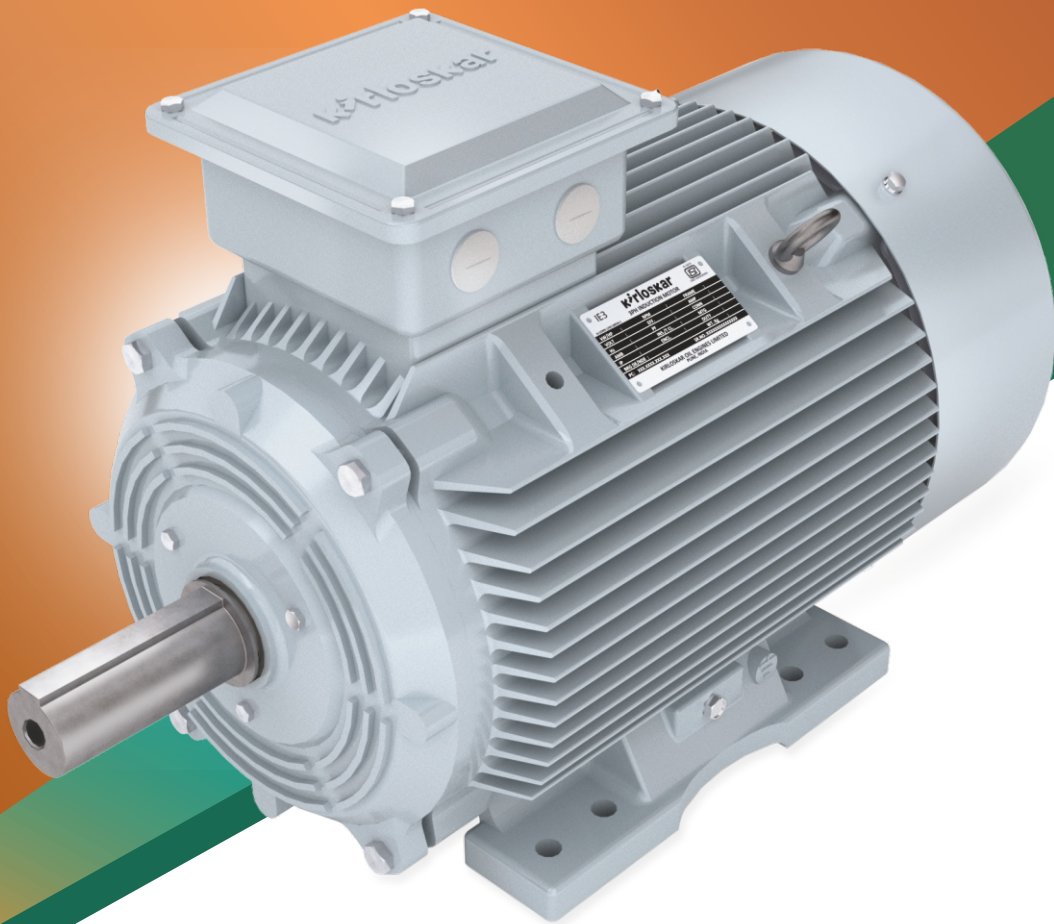

kirloskar
motors

Performance Beyond Expectations

KIRLOSKAR OIL ENGINES LIMITED

A Kirloskar Group Company

Range & Standard Features:

Parameters	Details
kW	3.7- 45
Pole	2, 4, 6
Efficiency level	IE3 as per IS 12615 : 2018
Frame	KM132S - KM225M
Operating Voltage	415V±10%
Frequency	50Hz±5%
Combined variation	10% (Absolute)
Duty	S1-Continuous
Type of rotor	Squirrel cage
Enclosure	TEFC (Totally enclosed fan cooled)
Degree of Protection	IP 55
Ambient temperature	50 °C
Temperature rise	70 °C
Insulation class	Class 'F'
Altitude	≤ 1000 Meters from mean sea level
Relative humidity	Up to 95%
Atmospheric conditions	Tropical corrosive
Dimensions	As per IS 1231 / IS 2223 / IEC 60072
Mounting	B3, B35 (with dual mounting holes) & B5
Dynamic balancing	Grade 2.5 as per ISO 1940
General enclosure material	Cast Iron (FG200 grade)
Type of cooling	IC411
Terminal box position	TOP
Type of starting	DOL / STAR-DELTA / VVVF
Connection / No. of leads	DELTA / 6 nos.
Terminal arrangement	Stud type
Type of coupling	Direct/flexible
Direction of rotation	Bi-directional
Bearings	Deep groove anti-friction ball bearings
Greasing arrangement	Greased for life (L-10, 40000 Hrs.)
Bearings seal	Oil seal
Vibration level	As per IS 12075
Noise level	As per IS 12065
Paint shade	RAL 7046 (Tele-grey)

Optional Features:

- Class 'H' insulation
- Space heater & thermistor 160 frame & above
- TB RHS/LHS
- Non-standard shaft extension
- Standard double shaft extension
- One size higher terminal box
- Double compression cable gland
- Encoder mounting arrangement
- Flying leads

Cable Sizes & Cable Entry:

Sr. No.	Frame	Max. cable size	Cable entry
1	KM132	2X3CX10 mm ²	M25 X 1.5 - 2 Nos.
2	KM160	2X3CX25 mm ²	M25 X 1.5 - 2 Nos.
3	KM180	2X3CX35 mm ²	M25 X 1.5 - 2 Nos.
4	KM200	2X3CX50 mm ²	M40 X 1.5 - 2 Nos.
5	KM225	2X3CX95 mm ²	M40 X 1.5 - 2 Nos.

Bearing references:

Sr. No.	Frame	DE Bearing	NDE Bearing
1	KM132	6308 ZZ C3	6208 ZZ C3
2	KM160	6309 ZZ C3	6209 ZZ C3
3	KM180	6310 ZZ C3	6210 ZZ C3
4	KM200	6312 ZZ C3	6212 ZZ C3
5	KM225	6313 ZZ C3	6213 ZZ C3



Performance Beyond Expectations

1 Top-notch Power factor
Lower reactive power, reduced energy losses and lower bills
Saves money every month

2 DE Locking in all frames
Prevents jerk in the driven equipment and loosening of bearing due to low axial play
Prolonged lifespan of Motors and Equipments

3 Suitable for 55°C without deration
In temperature-varying applications
Consistent performance

4 Suitable for SF 1.15 at 50°C
Adaptable to intermittent overloads
Reliable, Saves cost

5 Lower Full load Current
Low energy consumption
Reduced carbon footprint

6 Dual mounting holes
Easy replacement of any existing motor of same frame size
Saves money & time

7 Low Starting current
Minimize voltage drops
Reduced burden on electrical supply system

8 Unique design
Easy interchangeability of TB from RHS to LHS and B3 to B35 mounting at site
Saves time & money

9 Suitable for Variable Torque applications
with Class B rise
Highly Reliable & Durable

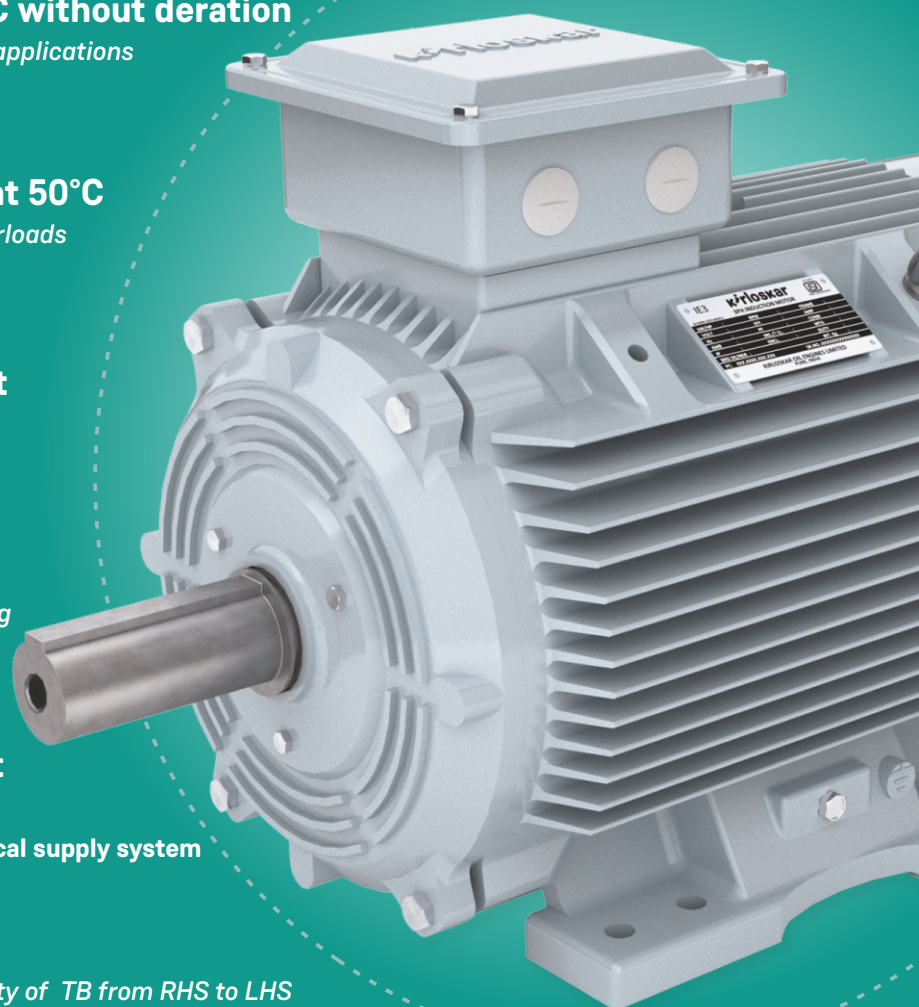

Performance Data - IE3 Efficiency Cast Iron Series:

VOLTAGE	415 ± 10%	AMBIENT	50 °C	INSULATION CLASS	F
FREQUENCY	50 ± 5%	DUTY	S1	THERMAL CLASS	B
COMBINED VARIATION	10%	EFFICIENCY CLASS AS PER IEC60034-30-1:2014, IS12615:2018			

2 POLE															
Product code	Output	Frame Size	Rated Speed	FLC	FLT	% Efficiency			Power Factor			Starting Current	Starting Torque	Pull Out Torque	GD ²
	kW		RPM	A	kg-m	FL	3/4 FL	1/2 FL	FL	3/4 FL	1/2 FL	% FLC	% FLT	% FLT	kg-m ²
KM3.5T50.AAC.TSS.B03	5.5	KM132S	2920	9.9	1.83	89.2	89.2	87.5	0.87	0.83	0.74	700	200	250	0.063
KM3.7T50.AAC.TSS.B03	7.5	KM132S	2920	13.2	2.5	90.1	90.1	88	0.88	0.84	0.75	700	225	275	0.077
KM3.9T30.ABC.TSS.B03	9.3	KM160M	2935	16	3.09	90.7	90.7	88.5	0.9	0.88	0.8	700	200	250	0.15
KM3.11T0.ABC.TSS.B03	11	KM160M	2920	19	3.67	91.2	91.2	89.8	0.9	0.88	0.81	700	200	250	0.15
KM3.15T0.ABC.TSS.B03	15	KM160M	2930	25	4.99	91.9	91.9	91	0.9	0.88	0.81	700	225	275	0.19
KM3.18T5.ALC.TSS.B03	18.5	KM160L	2935	31	6.14	92.4	92.4	92	0.9	0.88	0.82	700	225	275	0.23
KM3.22T0.ACC.TSS.B03	22	KM180M	2935	37	7.3	92.7	92.7	91.5	0.9	0.88	0.82	650	200	250	0.41
KM3.30T0.ANC.TSS.B03	30	KM200L	2955	50	9.89	93.3	93.3	90.7	0.9	0.88	0.8	700	200	250	0.7
KM3.37T0.ANC.TSS.B03	37	KM200L	2960	60	12.18	93.7	93.7	92.5	0.91	0.89	0.85	700	225	275	0.92
KM3.45T0.AQC.TSS.B03	45	KM225M	2965	73	14.78	94	94	92.5	0.91	0.89	0.86	700	225	275	1.82

4 POLE															
Product code	Output	Frame Size	Rated Speed	FLC	FLT	% Efficiency			Power Factor			Starting Current	Starting Torque	Pull Out Torque	GD ²
	kW		RPM	A	kg-m	FL	3/4 FL	1/2 FL	FL	3/4 FL	1/2 FL	% FLC	% FLT	% FLT	kg-m ²
KM3.5T50.BAC.TSS.B03	5.5	KM132S	1455	10	3.68	89.6	89.6	89	0.85	0.8	0.75	650	200	250	0.149
KM3.7T50.BKC.TSS.B03	7.5	KM132M	1455	13.6	5.02	90.4	90.4	89	0.85	0.8	0.7	650	200	250	0.183
KM3.9T30.BBC.TSS.B03	9.3	KM160M	1465	17	6.18	91	91	90	0.85	0.82	0.75	650	200	250	0.32
KM3.11T0.BBC.TSS.B03	11	KM160M	1465	20	7.31	91.4	91.4	91	0.85	0.82	0.75	650	200	250	0.35
KM3.15T0.BLC.TSS.B03	15	KM160L	1465	27	9.97	92.1	92.1	91.2	0.85	0.82	0.75	650	200	250	0.46
KM3.18T5.BCC.TSS.B03	18.5	KM180M	1472	32	12.24	92.6	92.6	92	0.87	0.84	0.78	650	200	250	0.81
KM3.22T0.BMC.TSS.B03	22	KM180L	1472	37	14.56	93	93	91.5	0.88	0.84	0.78	650	200	250	0.97
KM3.30T0.BNC.TSS.B03	30	KM200L	1472	52	19.85	93.6	93.6	92.6	0.86	0.82	0.77	700	200	250	1.84
KM3.37T0.BPC.TSS.B03	37	KM225S	1480	64	24.35	93.9	93.9	92	0.85	0.82	0.74	700	250	300	2.02
KM3.45T0.BQC.TSS.B03	45	KM225M	1480	78	29.61	94.2	94.2	93	0.85	0.82	0.74	700	250	300	2.31

6 POLE															
Product code	Output	Frame Size	Rated Speed	FLC	FLT	% Efficiency			Power Factor			Starting Current	Starting Torque	Pull Out Torque	GD ²
	kW		RPM	A	kg-m	FL	3/4 FL	1/2 FL	FL	3/4 FL	1/2 FL	% FLC	% FLT	% FLT	kg-m ²
KM3.3T70.CAC.TSS.B03	3.7	KM132S	960	8.5	3.75	86.5	86.5	86	0.7	0.64	0.55	600	180	225	0.149
KM3.5T50.CKC.TSS.B03	5.5	KM132M	955	11.8	5.61	88	88	87.5	0.74	0.7	0.6	600	180	225	0.206
KM3.7T50.CBC.TSS.B03	7.5	KM160M	970	15	7.53	89.1	89.1	88.5	0.8	0.75	0.68	600	175	225	0.45
KM3.9T30.CLC.TSS.B03	9.3	KM160L	970	18	9.34	89.8	89.8	89	0.8	0.75	0.68	600	175	225	0.56
KM3.11T0.CLC.TSS.B03	11	KM160L	970	21	11.05	90.3	90.3	89.3	0.8	0.75	0.68	600	175	225	0.59
KM3.15T0.CMC.TSS.B03	15	KM180L	975	27	14.98	91.2	91.2	90.5	0.84	0.81	0.75	600	200	250	1.17
KM3.18T5.CNC.TSS.B03	18.5	KM200L	978	33	18.42	91.7	91.7	90.5	0.84	0.81	0.73	600	200	250	1.84
KM3.22T0.CNC.TSS.B03	22	KM200L	980	40	21.87	92.2	92.2	91	0.84	0.81	0.73	600	200	250	2.08
KM3.30T0.CQC.TSS.B03	30	KM225M	985	53	29.66	92.9	92.9	92	0.84	0.8	0.72	650	200	250	3.67

Dimensional Drawing For TEFC, Foot Mounted (B3) Motors: Frames: KM132 to KM225

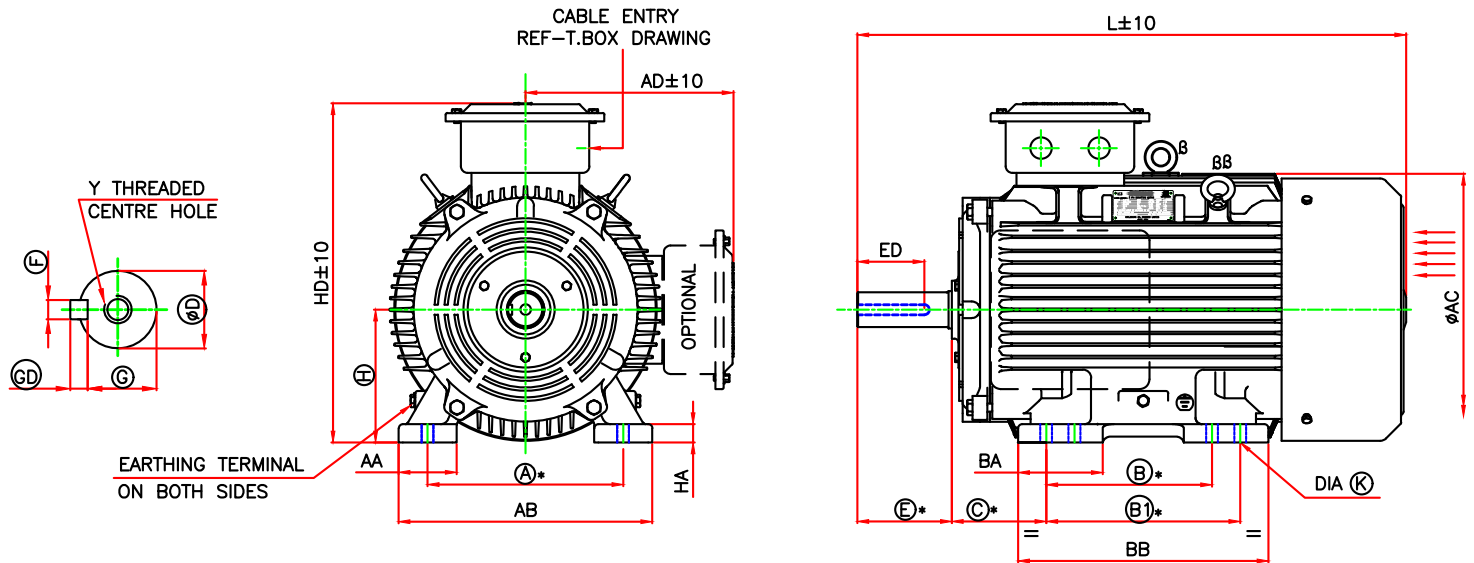

POLE: ALL

FRAME	FOOT FIXING										OVER ALL					SHAFT						
	A	B	B1	C	H TOL.	AA	AB	BA	BB	K	AC	L	HD	AD	HA	D TOL.	E	ED	F TOL.	GD TOL.	G	Y
KM132S/M	216	140	178	89	132/131.5	50	253	83	215	12/12.5	274	500	340	210	16	38.018/38.002	80	60	10/9.964	8.0/7.9	33.0/32.8	M12X28
KM160M/L	254	210	254	108	160/159.5	70	306	102	302	14.5/15	328	665	415	255	22	42.018/42.002	110	80	12/11.957	8.0/7.9	37.0/36.8	M16X36
KM180M/L	279	241	279	121	180/179.5	70	340	105	321	14.5/15	365	720	455	275	24	48.018/48.002	110	80	14/13.957	9.0/8.9	42.5/42.3	M16X36
KM200L	318	-	305	133	200/199.5	70	380	111	357	18.5/19	418	770	520	26	55.030/55.011	110	80	16/15.957	10/9.9	49.0/48.8	M20X42	

POLE: 2

FRAME	FOOT FIXING										OVER ALL					SHAFT						
	A	B	B1	C	H TOL.	AA	AB	BA	BB	K	AC	L	HD	AD	HA	D TOL.	E	ED	F TOL.	GD TOL.	G	Y
KM225M	356	286	311	149	225/224.5	80	435	110	370	18.5/19	462	865	585	360	28	55.030/55.011	110	80	16/15.957	10/9.9	49.0/48.8	M20X42

POLE: 4P&UP

FRAME	FOOT FIXING										OVER ALL					SHAFT						
	A	B	B1	C	H TOL.	AA	AB	BA	BB	K	AC	L	HD	AD	HA	D TOL.	E	ED	F TOL.	GD TOL.	G	Y
KM225S/M	356	286	311	149	225/224.5	80	435	110	370	18.5/19	462	865	585	360	28	60.030/60.011	140	110	18/17.957	11/10.9	53.0/52.8	M20X42

NOTES:-

- 1) ALL DIMENSIONS ARE IN mm
- 2) RINGED DIMENSIONS ARE AS PER IS:1231 / IEC:60072 - 1
- 3) * TOLERANCES ON MANDATORY DIMENSIONS ARE AS PER IS:1231 / IEC:60072
- 4) MINIMUM CLEARANCE AFTER FANCOVER FOR AIR INLET: 100mm
- 5) TERMINAL BOX TOP: STANDARD FEATURE
TERMINAL BOX RHS: ON REQUEST
- 6) β: APPLICABLE FOR 132 TO 225 RHS T. BOX POSITION & 132 - T. BOX POSITION
- 7) ββ: APPLICABLE FOR 160 TO 225 TOP T. BOX POSITION

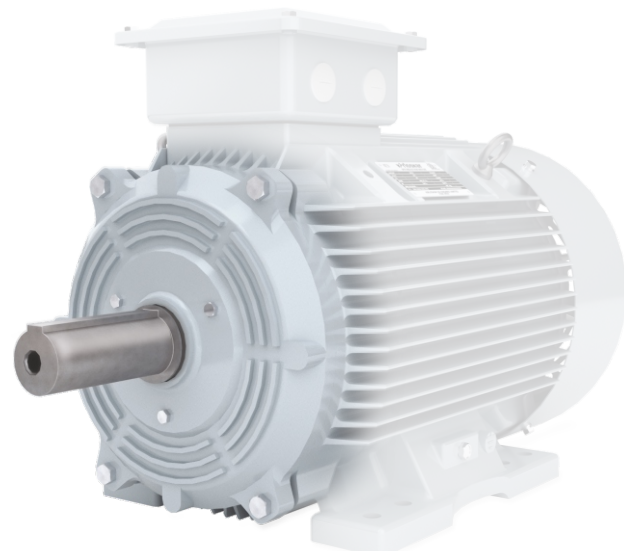

Dimensional Drawing For TEFC, Flange Mounted (B5) Motors: Frames: KM132 to KM225

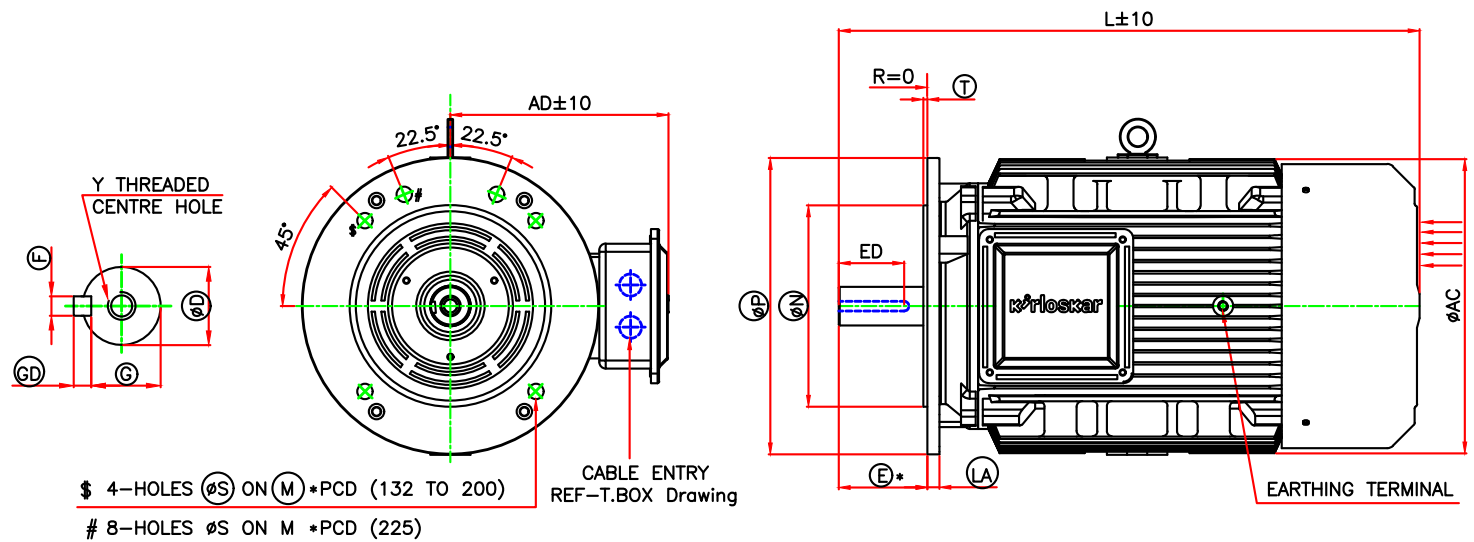

POLE: ALL

FRAME	FLANGE FIXING						OVER ALL				SHAFT					
	M TOL.	N TOL.	P	S	T	LA	AC	L	AD	D TOL.	E	ED	F TOL.	GD TOL.	G	Y
KM132S/M	265	230.016/229.987	300	15	4	12	274	500	210	38.018/38.002	80	60	10/9.964	8.0/7.9	33.0/32.8	M12X28
KM160M/L	300	250.016/249.987	350	19	5	13	328	665	255	42.018/42.002	110	80	12/11.957	8.0/7.9	37.0/36.8	M16X36
KM180M/L	300	250.016/249.987	350	19	5	13	365	720	275	48.018/48.002	110	80	14/13.957	9.0/8.9	42.5/42.3	M16X36
KM200L	350	300.016/299.984	400	19	5	16	418	770	320	55.030/55.011	110	80	16/15.957	10/9.9	49.0/48.8	M20X42

POLE: 2

FRAME	FLANGE FIXING						OVER ALL				SHAFT					
	M TOL.	N TOL.	P	S	T	LA	AC	L	AD	D TOL.	E	ED	F TOL.	GD TOL.	G	Y
KM225M	400	350.018/349.982	450	19	5	16	462	865	360	55.030/55.011	110	80	16/15.957	10/9.9	49.0/48.8	M20X42

POLE: 4P & UP

FRAME	FLANGE FIXING						OVER ALL				SHAFT					
	M TOL.	N TOL.	P	S	T	LA	AC	L	AD	D TOL.	E	ED	F TOL.	GD TOL.	G	Y
KM225S/M	400	350.018/349.982	450	19	5	16	462	865	360	60.030/60.011	140	110	18/17.957	11/10.9	53.0/52.8	M20X42

NOTES:-

- 1) ALL DIMENSIONS ARE IN mm
- 2) RINGED DIMENSIONS ARE AS PER IS:2223 / IEC:60072-1
- 3) * TOLERANCES ON MANDATORY DIMENSIONS ARE AS PER IS:2223 / IEC:60072
- 4) MINIMUM CLEARANCE AFTER FANCOVER FOR AIR INLET: 100mm



Dimensional Drawing For TEFC, Foot Cum Flange Mounted (B35) Motors: Frames: KM132 to KM225

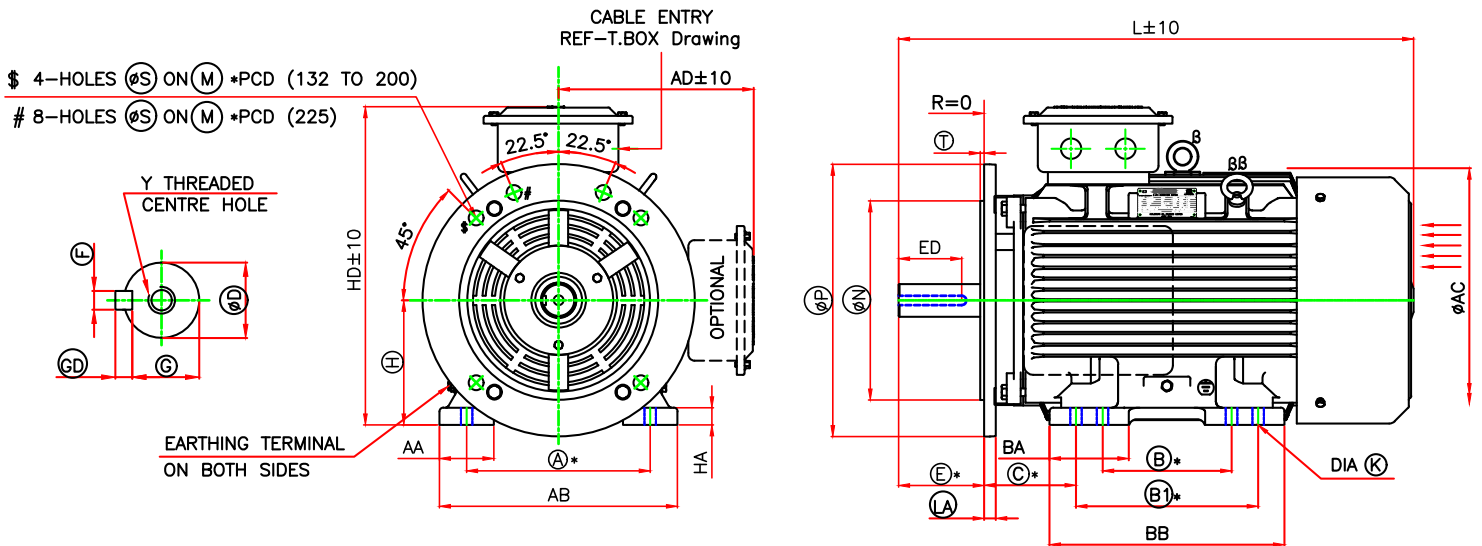

POLE: ALL

RAME	FOOT FIXING										OVER ALL					SHAFT						
	A	B	B1	C	H TOL.	AA	AB	BA	BB	K	AC	L	HD	AD	HA	D TOL.	E	ED	F TOL.	GD TOL.	G	Y
KM132S/M	216	140	178	89	132/131.5	50	253	83	215	12/12.5	274	500	340	210	16	38.018/38.002	80	60	10/9.964	8.0/7.9	33.0/32.8	M12X28
KM160M/L	254	210	254	108	160/159.5	70	306	102	302	14.5/15	328	665	415	255	22	42.018/42.002	110	80	12/11.957	8.0/7.9	37.0/36.8	M16X36
KM180M/L	279	241	279	121	180/179.5	70	340	105	321	14.5/15	365	720	455	275	24	48.018/48.002	110	80	14/13.957	9.0/8.9	42.5/42.3	M16X36
KM200L	318	-	305	133	200/199.5	70	380	111	357	18.5/19	418	770	520	320	26	55.030/55.011	110	80	16/15.957	10/9.9	49.0/48.8	M20X42

POLE: 2

RAME	FOOT FIXING										OVER ALL					SHAFT						
	A	B	B1	C	H TOL.	AA	AB	BA	BB	K	AC	L	HD	AD	HA	D TOL.	E	ED	F TOL.	GD TOL.	G	Y
KM225M	356	286	311	149	225/224.5	80	435	110	370	18.5/19	462	865	585	360	28	55.030/55.011	110	80	16/15.957	10/9.9	49.0/48.8	M20X42

POLE: 4P & UP

RAME	FOOT FIXING										OVER ALL					SHAFT						
	A	B	B1	C	H TOL.	AA	AB	BA	BB	K	AC	L	HD	AD	HA	D TOL.	E	ED	F TOL.	GD TOL.	G	Y
KM225S/M	356	286	311	149	225/224.5	80	435	110	370	18.5/19	462	865	585	360	28	60.030/60.011	140	110	18/17.957	11/10.9	53.0/52.8	M20X42

FRAME	FLANGE FIXING					
	M TOL.	N TOL.	P	S	T	LA
KM132S/M	265	230.016/229.987	300	15	4	12
KM160M/L	300	250.016/249.987	350	19	5	13
KM180M/L	300	250.016/249.987	350	19	5	13
KM200L	350	300.016/299.984	400	19	5	16
KM225S/M	400	350.018/349.982	450	19	5	16

NOTES:-

- 1) ALL DIMENSIONS ARE IN mm
- 2) RINGED DIMENSIONS ARE AS PER IS:1231 / IS:2223 / IEC:60072 - 1
- 3) * TOLERANCES ON MANDATORY DIMENSIONS ARE AS PER IS:1231 / IS:2223 / IEC:60072
- 4) MINIMUM CLEARANCE AFTER FANCOVER FOR AIR INLET: 100mm
- 5) TERMINAL BOX TOP: STANDARD FEATURE
TERMINAL BOX RHS: ON REQUEST
- 6) β: APPLICABLE FOR 132 TO 225 RHS T. BOX POSITION & 132 - T. BOX POSITION
- 7) ββ: APPLICABLE FOR 160 TO 225 TOP T. BOX POSITION

TERMINAL BOX ARRANGEMENT FRAME: KM132 TO KM225

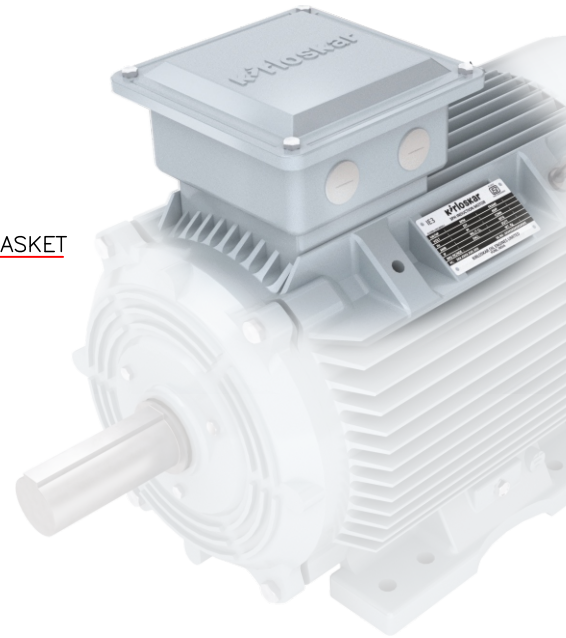
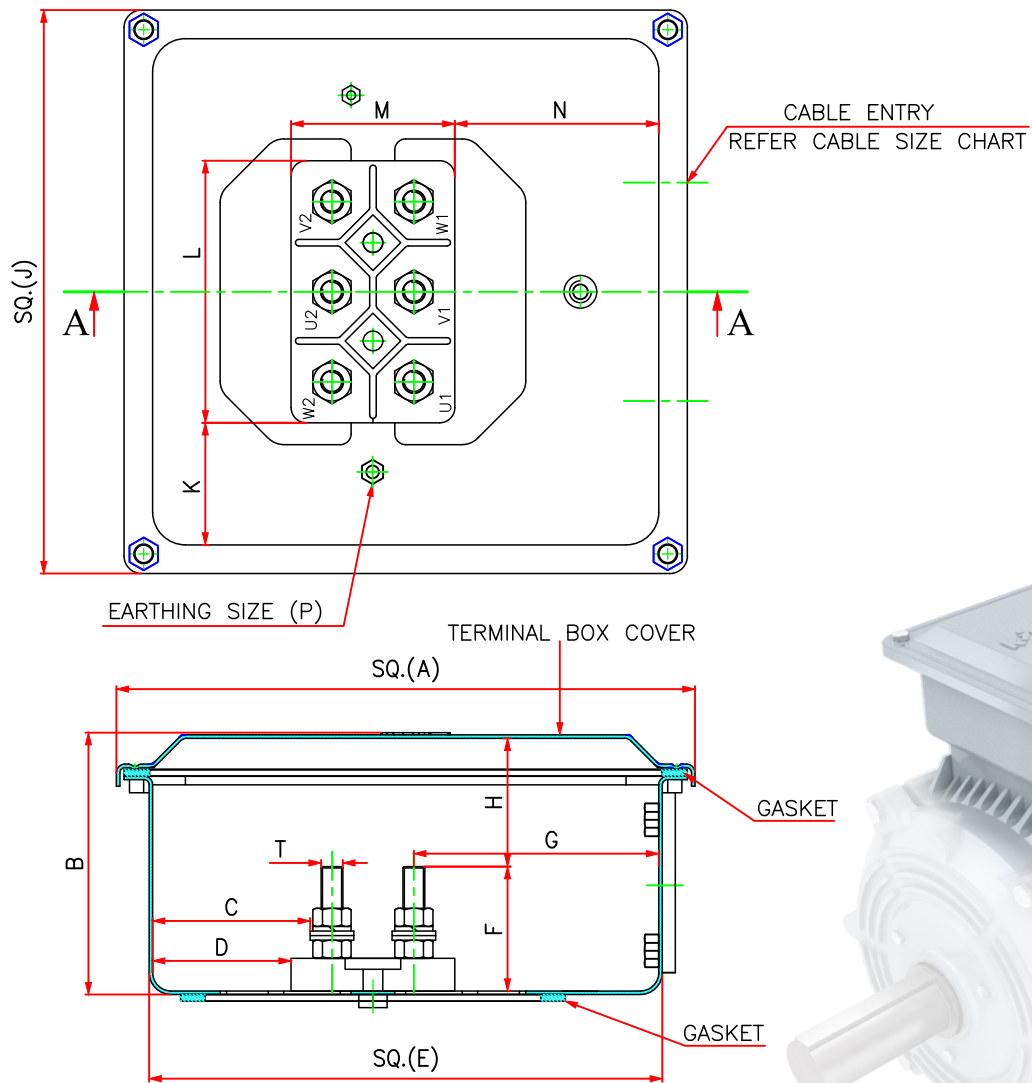

SECTION:A-A

FRAME	A	B	C	D	E	F	G	H	T	J	K	L	M	N	P
KM132	125	68	34	29	100	26.5	39	38	M5	119	17	64	40	29	M5
KM160-KM180	191	86	57	49	155	57	63	26	M6	185	34	85	55	49	M6
KM200	225	103	54	45	190	65	92	34	M8	218	42	104	68	75	M8
KM225	265	120	72	63	235	57	112	59	M10	258	56	120	75	93	M10

NOTE:

- * TERMINAL BOX CAN BE ROTATED IN 360° IN STEPS OF 90°.
- * ONE EARTHING TERMINAL IS PROVIDED INSIDE THE MAIN TERMINAL BOX.
- * CABLE GLANDS ARE NOT IN KIRLOSKAR SCOPE OF SUPPLY.

Tolerance on Electrical Performance:

As per IEC 60034-1 or IS 15999-1, the following tolerances are permitted:

- Efficiency η at

kW \leq 150 kW: -15% of $(1 - \eta)$

kW $>$ 150 kW: -10% of $(1 - \eta)$

Where η is a efficiency mentioned in decimals.

- Power factor = $-1/6 (1 - \cos\phi)$
Minimum absolute value: 0.02
Maximum absolute value: 0.07
- $P_N < 1$ kW : $\pm 30\%$ of the slip
- $P_N > 1$ kW : $\pm 20\%$ of the slip
- Locked-rotor Current / Starting Current / SCC: +20% of Full Load Current (FLC)
- Locked-rotor Torque / Starting Torque / STT: -15% to +25 % of indicated value.
- Breakdown Torque / Pull out Torque / POT: -10% of indicated value.
- Moment of Inertia (or GD^2) ± 10 % of the value.

Voltage and Frequency Variation:

- As per IS 12615 : 2018, motors shall be capable of delivering rated output with:
 - a. Terminal voltage differing from its rated value by not more than $\pm 10\%$
 - b. Frequency differing from its rated value by not more than $\pm 5\%$
 - c. Combined variation - The sum of absolute percent variation of (a) and (b) not exceeding 10%.

In the case of continuous operation at the extreme voltage limits specified at (a) and (b), the temperature rise limits of the winding specified in IS 15999 (Part 1)/IEC 60034-1 shall not exceed by more than 20 K.

In such cases, motor may be designed with higher class of insulation.

Motors operated under the extreme conditions of voltage and/or frequency specified in (a) and (b), the performance values given in the selection tables may not necessarily comply with IS 12615

Efficiency and Power Factor:

The nominal efficiency (η) and the power factor ($\cos\phi$) for motors is listed in the tables.

Efficiency and other performance figures are committed at rated voltage and frequency.

Rated Speed and Direction of Rotation:

The rated speeds are applicable for the rated data. The synchronous speed changes proportionally with the line frequency. The motors are suitable for bi-directional rotation.

Default direction of rotation is Clockwise from DE when L1,L2 and L3 are connected to U1,V1 and W1 respectively.

Counter clockwise rotation is achieved by interchanging any of the two phases.

Rated Torque:

The rated torque in kg-m delivered at the motor shaft is

$$T = (974 \times P)/N$$

Where P is power in kW & N is Full Load Speed in RPM.



Reference Standards:

All Kirloskar Motors shall comply with the latest International and Indian Standards.

These are as under:

List of International Standards:

1. IEC60034-1: Rotating Electrical Machines, Part-1; Rating and Performance.
2. IEC60034-2-1 Standard Methods for Determining Losses and Efficiency.
3. IEC60034-5: Degree of Protection.
4. IEC60034-6: Method of Cooling.
5. IEC60034-9: Noise Limits.
6. IEC60034-14: Mechanical Vibrations Measurement, Evaluation and Limits of Severity.
7. IEC60034-30: Efficiency Classes of Single Speed Three Phase Squirrel Cage Induction Motors.
8. IEC60072-1: Dimensions and Output Ratings of Electrical Machines.

List of Indian Standards:

1. IS1231: Dimensions of Three Phase Induction Motors- Foot Mounted.
2. IS2223: Dimensions of Flange Mounted AC Induction Motors.
3. IS2253: Designations of Types of Construction and Mounting Arrangements for Rotating Electrical Machines.
4. IS4029: Guide for Testing Three Phase Induction Motors.
5. IS/IEC60034-5: Degree of Protection Provided by Enclosures for Rotating Electrical Machinery.
6. IS6362: Designation of Method of Cooling for Rotating Electrical Machines.
7. IS7538: Three Phase Squirrel Cage Induction Motors for Centrifugal Pumps for Agricultural Applications.
8. IS12065: Permissible Limits of Noise Levels for Rotating Electrical Machines.
9. IS12075: Mechanical Vibrations of Rotating Electrical Machines; Measurements, Evaluations and Limits of Vibration Severity.
10. IS12615: Efficiency Classes and Performance Specification.
11. IS15999: Rotating Electrical Machines (Part 1 & 2)

kirloskar motors

Performance Beyond Expectations



For more information, please contact us at “head.motors@kirloskar.com”

kirloskar
Oil Engines

www.kirloskaroilengines.com

KIRLOSKAR OIL ENGINES LIMITED

A Kirloskar Group Company

Laxmanrao Kirloskar Road, Khadki,
Pune 411 003 INDIA.

 **960 411 4411 / 960 411 8811**



Stamp of
Authorised
Representative

Mark bearing word 'Kirloskar' in any form as a suffix or prefix is owned by Kirloskar Proprietary L td. and Kirloskar Oil Engines Ltd. is the Permitted User.
This Catalog is copyrighted and may not be reproduced in any form not even parts of it, without previous written permission by copyright owners, Kirloskar Oil Engines L td.
Product improvement is a continuous process. Kindly contact Kirloskar for latest information.
The product images are for illustration purposes only. It may not be the exact replica of the product.