







6455 S. Dean Martin Dr., Suite C \* Las Vegas, Nevada 89118  
Telephone: (702) 309-8326

## Sample Layouts

**Island Booth: Electrical layouts are required for all island booths.**

Standard Location:

Standard location in an island booth is normally at the center of the booth. Please provide a floor plan because facilities vary in the locations where power can be drawn.

What should be on a completed floor plan:

1. Main drop or outlet location. Island booths do not have a back wall so the main location operates as the point which all other power will be distributed from. There can often be many cords or cables in this location so it is often best to be in a closet, under a table or a location out of site.
2. Location of all other outlets. This includes the dimensions where the outlets will be placed. Without dimensions, outlets are likely to end up in the wrong locations in the booth.
3. Power requirements in each location. This can be 500 Watts / 1000 Watts / 2000 Watts or even 10 Amp 208 volt 3 Phase
4. Booth Orientation. This is especially useful for island booths. It helps us understand which side is which in the booth.

Completed Layout:

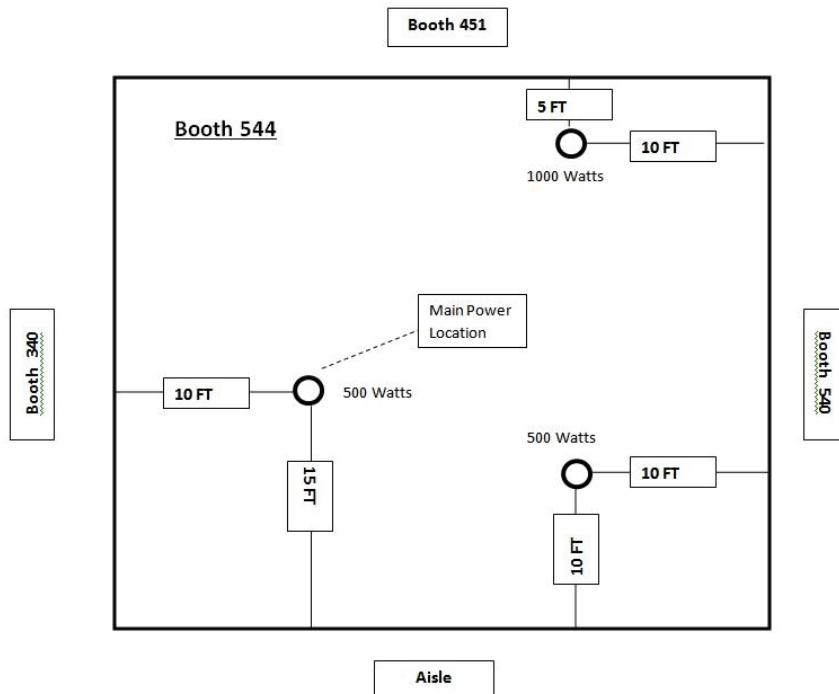

**Inline or Peninsula Booths:**

Layouts are only required when outlets are needed at any other location than the back of the booth.

Standard Location:

In Line

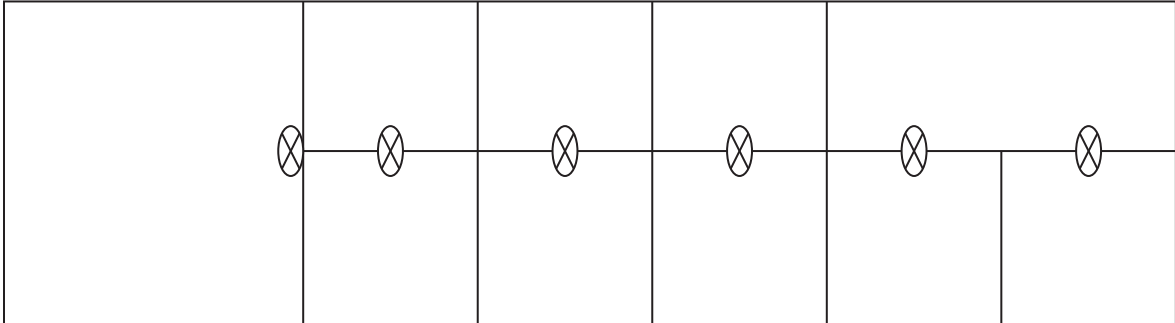

Completed Layout:

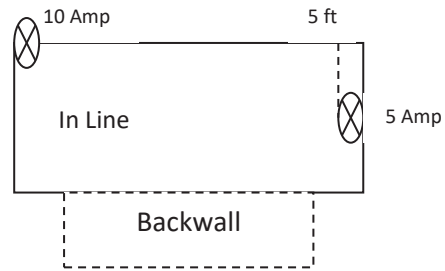
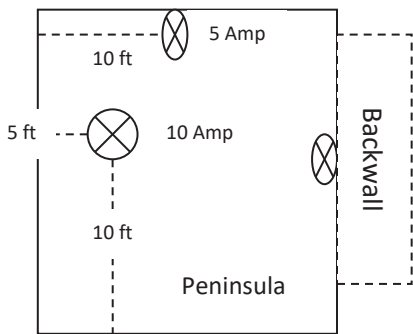

Thank you for your business!