

Welcome to the Webinar on
MEDITATION for Good Health
where we shall learn to
Meditate.

Before taking any new learning or polishing an old skill, or even when doing anything, we must search within ourselves, the purpose, by asking

Why must I do or learn this.

Purposeful activities get **help and boost from Nature.**

This is Nature's Law.

THE FIRST STEP

We must start by asking ourselves the question Why do I want to Meditate?

Just like we ask ourselves, why am I undertaking this journey?

Why am I buying this?

Let us take some time to answer this before we proceed.

If you have answered that Meditation is beneficial, then please also ask yourself how will it benefit you, or which of the benefits that you have heard and want. If you have answered (hopefully you have found the innermost or deepest reason, and truthfully accepted) that I want to learn to Meditate because everyone is doing it, and I don't want to be left behind, then you are the right candidate for learning to Meditate.

Meditation is the second last step of the eight steps of Yoga, culminating in Samadhi. But before we learn to Meditate, we **must** take the earlier steps of Yama, Niyama, Asana, Pranayama, Pratyahara and Dharana before Dhyana or Meditation.

Yama and Niyama are the first two steps which **purify and strengthen** our minds through moral and ethical exercises.

Yama is **restraining** harmful thoughts and Impulses, Niyama is **cultivating** good habits.

If a person has mastered the first two steps perfectly then the next two steps of Yoga, the third and fourth, which are **Asana and Pranayama** are automatic and effortless. A person does not have struggle as our posture and breathing depend very much on our ability to control our impulses and our daily habits, which is Yama & Niyama. Be Tolerant with others, and Strict with Oneself is the Mantra.

The fifth step of Yoga is **Pratyahara** or withdrawing the senses from their objects of enjoyment. This is the most crucial step not only before we **learn to Meditate**, but even while learning any new subject or skill, doing any business, especially related to the **stock markets**, working for a solution to a problem, and even to be just happy and healthy. To achieve success in any field of life we must be able to control and detach our senses.

Pratyahara is very similar to Mindfulness, but much older and a better technique that goes deep within **one's inner psyche, where the power to control of our senses is situated.**

Pratyahara is removing our attention from **things outside** to within our own selves. It is giving up the desire to know what others are doing, and refrain from doing activities and thoughts that waste our energies. It is taking our attention from the body and its emotional needs, higher into the intellectual and spiritual spheres called **Chidhakasha.**

As said earlier, the first question for any Meditator must be Why? Why is it necessary to complete all the steps before learning Meditation? The answer is because the Mind has to be **gradually taken up into the higher realms of Meditation.**

The gradual rise ensures the **mind is set** stabilizes and remains higher, Besides the gradual rise, these six steps are devised to give many rewards and benefits, like when facing an adverse situation, the mind spontaneously becomes calm and meditative. **Which is necessary to find a solution**

Just like a laser which is focussed light has more energy than dispersed light, similarly scattered mental energies are weak and make Meditation difficult. After bringing all the energies which were wandering outside, within us we must collect them in one place. This is **Dharana, the sixth step**. Just like we deposit money in a bank where it grows, similarly energy can also be conserved so that it amplifies, which is useful in attracting opportunities, manifesting the future of our choice, and healing our body and mind. **Power comes from boundless energy.**

Pratyahara is reducing energy and time wastage on unnecessary things, so that more time and attention (energy) can be given to things which help us to conserve our energy and strengthen our mind. It starts by making each day purposeful. Two habits that must be incorporated in our daily routine are shavasana and reading a book which can be either the Bhagvad Gita or any Upanishad. Shavasana for 10 minutes minimum with Yoga Nidra. After reading a minimum of 100 words from the book, contemplating on its essence and writing down our opinion and understanding is a must.

These two exercises remove our attention and energy usage from something unproductive and put them in something constructive. If we master this stage, Meditation is a cake walk. At this stage a lot of seekers decide to search for a teacher that directly takes up Meditation which is putting the cart before the horse. If you find it difficult to complete reading a 100 pages daily from a book only, then the second option is to chant Om for at least one thousand times. If you find that too difficult then you must devote a minimum of one hour per day doing selfless work, by teaching children, cooking for homeless, helping the sick by taking care of them or any such selfless activity. There are many more ideas, direct message me to find out.

Pratyaharaa is Mindfully spending time and energy only on being of service to others and to develop one's personality through restrains and renunciation.

By being socially active and trying to find pleasure in activities, places, people and possessions the crucial step of pratyahara cannot be ascended. Such people must not attempt to do Meditation without first reducing wastage of time and energies. Sanyam, Seva and

Tyaag develop Astikya Buddhi, which is not only necessary to go ahead to the next step of Dharana but it also helps in showing us the positive side of nature, and makes us stress free and stable minded.

Chidhakarasha

दीर्घानो धारानो

Before you sit down to read, study, meditate or think, calm your excited nerves.

Activities that require focus, or concentration should never be done immediately after strenuous physical exercise, household chores, or chattering.

Chidhakarasha

9320077468 for Mindfulness before Meditation

Learning Dharana, the 6th Step of Yoga.

The first five steps recommended by Patanjali are very important if we have to learn how to hold our mind in one place or Dharana. Out of the six, the first two steps of the Yogasutras, called Yama and Niyama purify and strengthen our Mind, and are important and a prerequisite for Pratyahara-Dharana-Dhyana

Meditation is the second last step of the eight steps of Yoga, culminating in Samadhi. Samadhi is when the object and subject merge into one. Example, I meditate for 28 minutes and 48 seconds on a cow, Samadhi is attained when I will loose my identity and merge my identity into the cow. This is **Yoga from the root Yuj or union.**

Dhyana or Meditation is the art of fixing the focus/attention of the mind on a single object or thought for 144 seconds which 12 times of **Dharana**, which is holding the mind for 12 seconds on a thought and after collecting our energies by **Pratyahara**.

Dissipated & Scattered mental energies make the mind weak. A weak mind cannot **focus**. A weak mind cannot perceive beyond superficiality and that is responsible for **faulty judgements and choices**. A weak mind perceives situations, circumstances and people, imperfectly. By collecting scattered energies, we make our mind strong.

Biophotons, also known as ultra-weak photon emissions (UPE), are a universal optical phenomenon for most living biological systems, including humans. They are electromagnetic radiation in the spectral region from 200 to 800 nanometers (nm). ▾

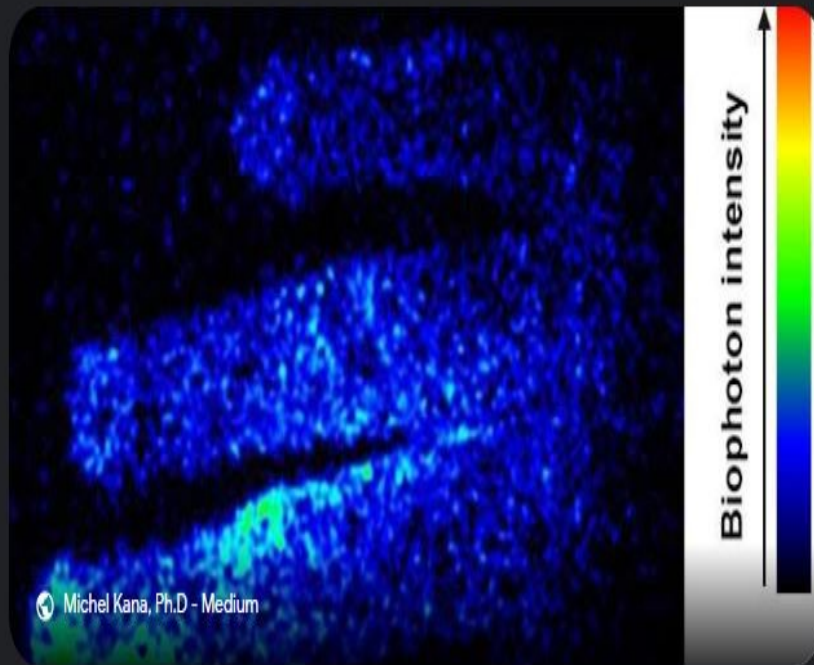

Biophotons are a result of the spontaneous emission of electromagnetic frequencies in the range of 240–650 nm. They are absorbed by all living beings, including humans. ▾

A weak mind tends to make the body weak. A strong mind can control the weak body by its positive response.

We must ask and find out, how a strong mind does not allow the body to become weak, and even when the body becomes weak, why does the body heal faster, with less pain when the mind is strong.

LAYERS TO THE SELF

5 KOSHAS

- Annamaya Kosha**
Physical body
- Pranamaya Kosha**
Energy Body
- Manomaya Kosha**
Emotional Body
- Vijananamaya Kosha**
Wisdom Body
- Anandamaya Kosha**
Bliss Body



The reason is strength is the medicine for all weaknesses, physical, mental, emotional and spiritual. If we collect money, we are able to buy costlier things, similarly if we collect mental energies, we can use them for higher purposes, like Dhyana.

Attempting to focus a weak mind can result in increased evil tendencies including lust and even madness. Page 12 of Yoga in day to day life, by Swami Brahmeshannda.

Chidhakarsha

वैशारिणी दीशिर्इ

GOOD HEALTH WEBINAR 03.08.2020



Higher Mental Strength, has many other benefits. Strength is like powerful microscope and it makes us see the workings of the universe better with a higher power. **We see a world where everyone's compulsions are struggles to become free, even if it means by lying, killing and cheating.**

The same world appears differently to a person with Higher Mental Strength. It becomes a perfect world, where there is no evil, no injustice and every happening is perfectly balanced. **Is it not a Meditative State that we wish to learn and achieve?**

Chidhakarasha

वीरारिणे द्वायोरइ

GOOD HEALTH WEBINAR 03.08.2020



Before we learn to train and discipline our mind we should know three things.

What is it made of, what is stored in it and its functions.

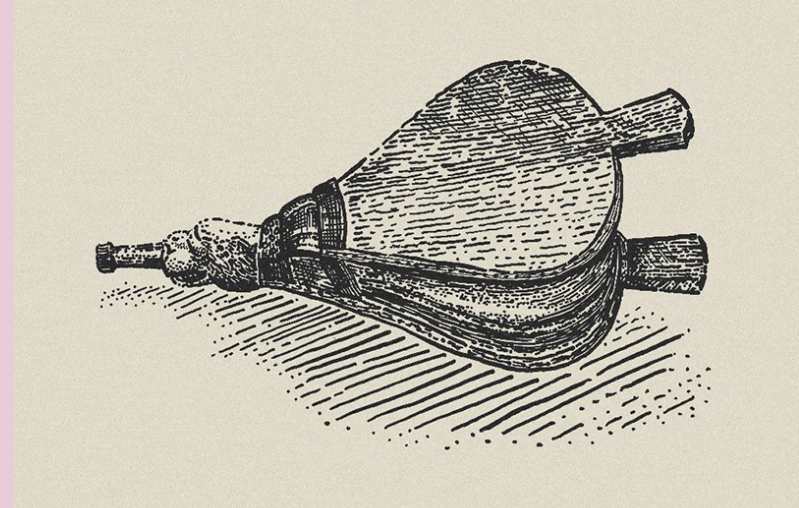
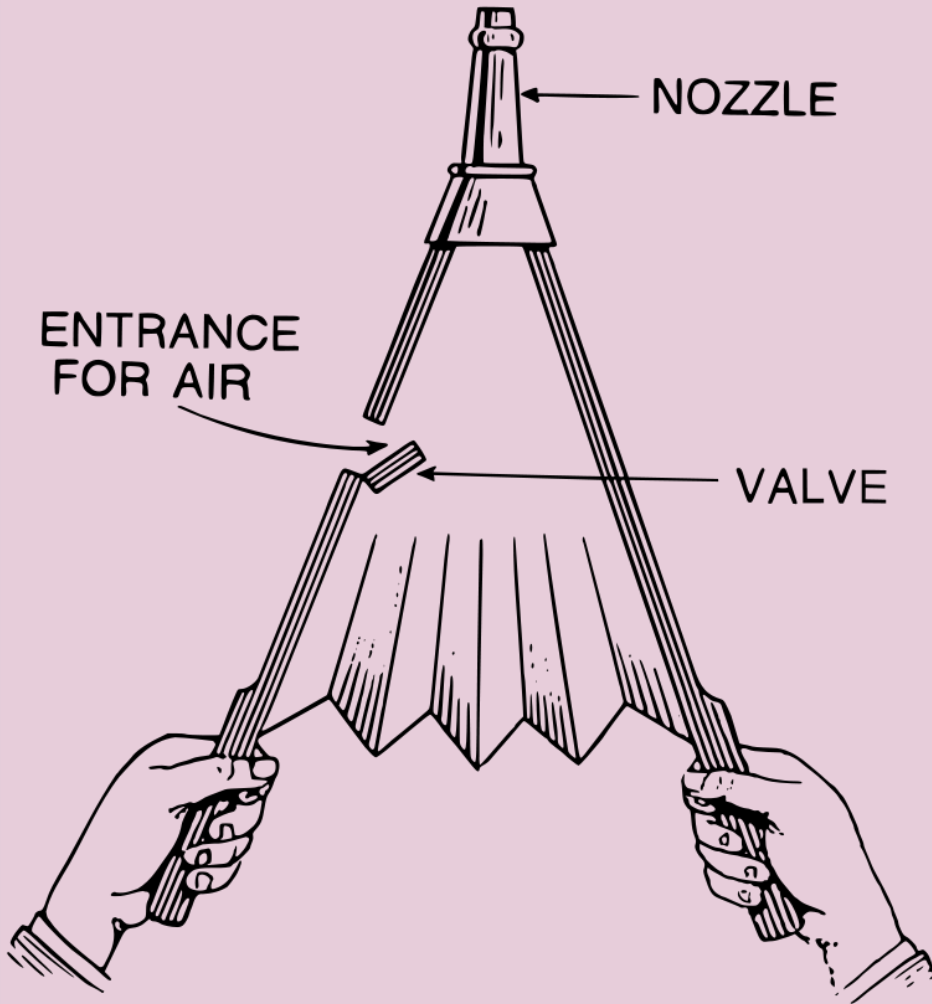

Fig. 46. Bellows.

Role of Lungs and Nerves in Disease.

ત્રિવિદ્યારણ

વૈજ્ઞાનિકો દોષોરૂ

GOOD HEALTH WEBINAR 03.08.2020

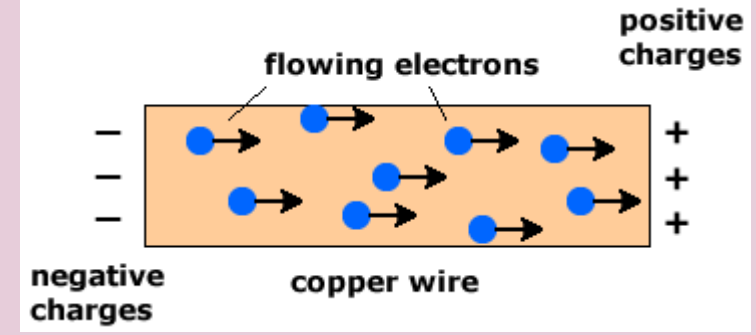

Just like electricity is conducted by wires, our nerves currents are carriers of emotions, feelings, energy and other subtle pranas.



What influences our thinking?

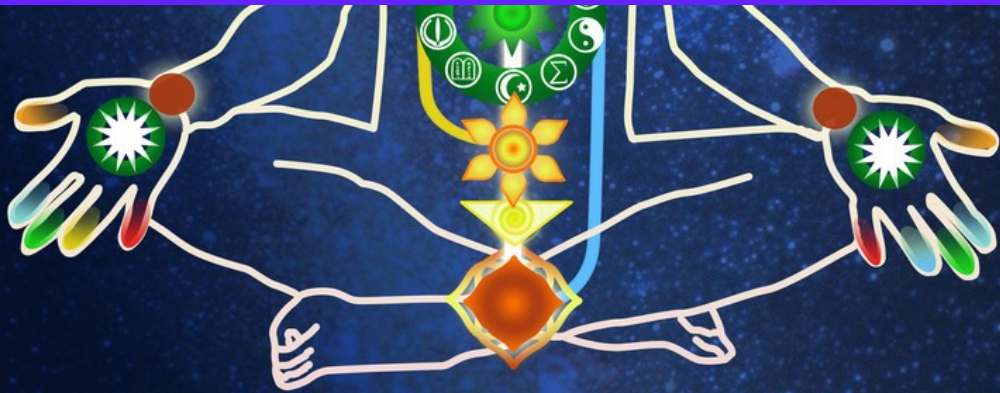

Our thoughts are more subtler than the nerve currents and control the health of our nerves.



તીર્થંકારશ્યા

વૈજ્ઞાનિકો દોષોરૂ

GOOD HEALTH WEBINAR 03.08.2020

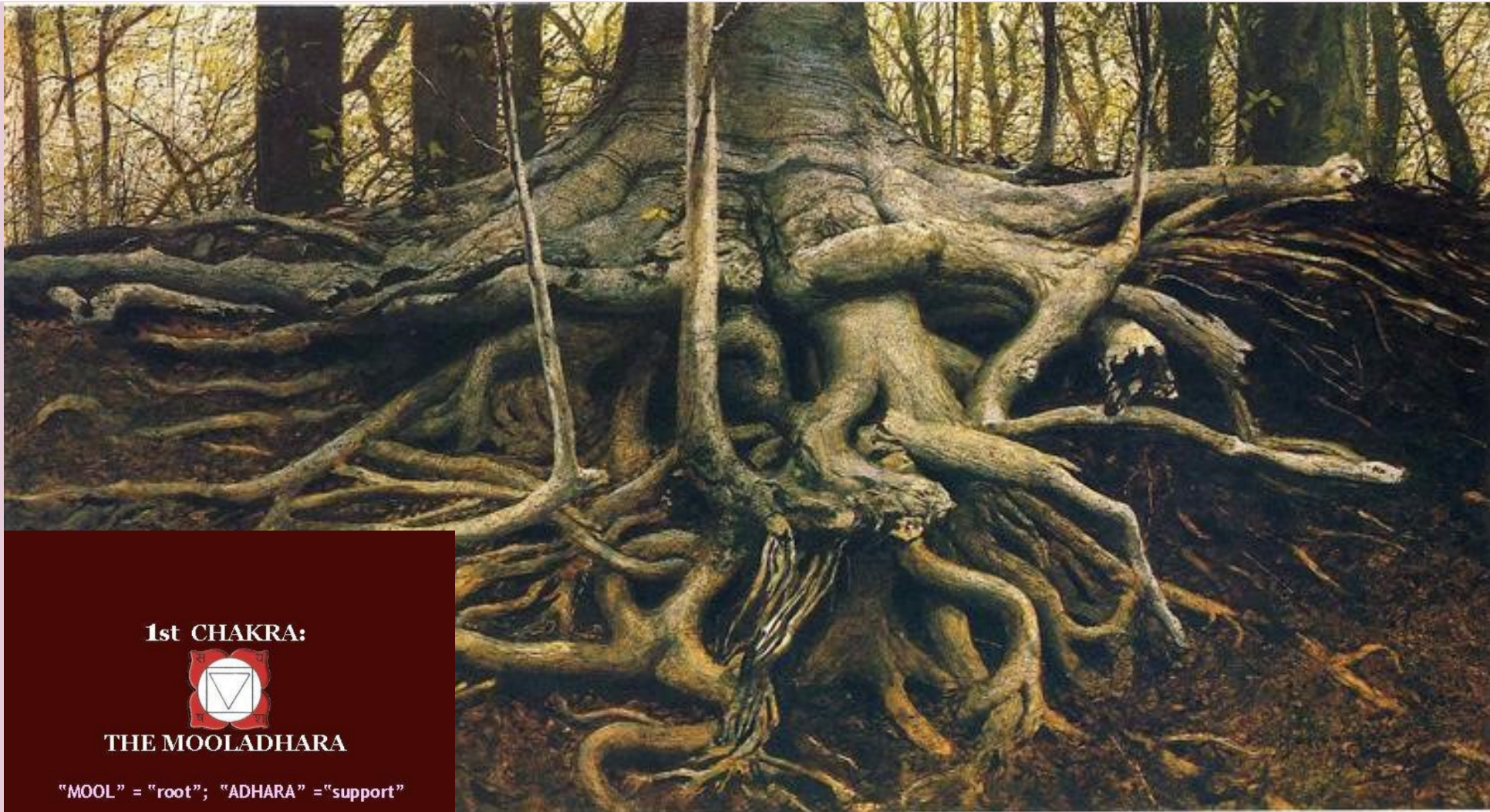

1st CHAKRA:



THE MOOLADHARA

"MOOL" = "root"; "ADHARA" = "support"

તીર્થંકરજ્ઞા

વૈજ્ઞાનિકો દોષોરૂ

GOOD HEALTH WEBINAR 03.08.2020



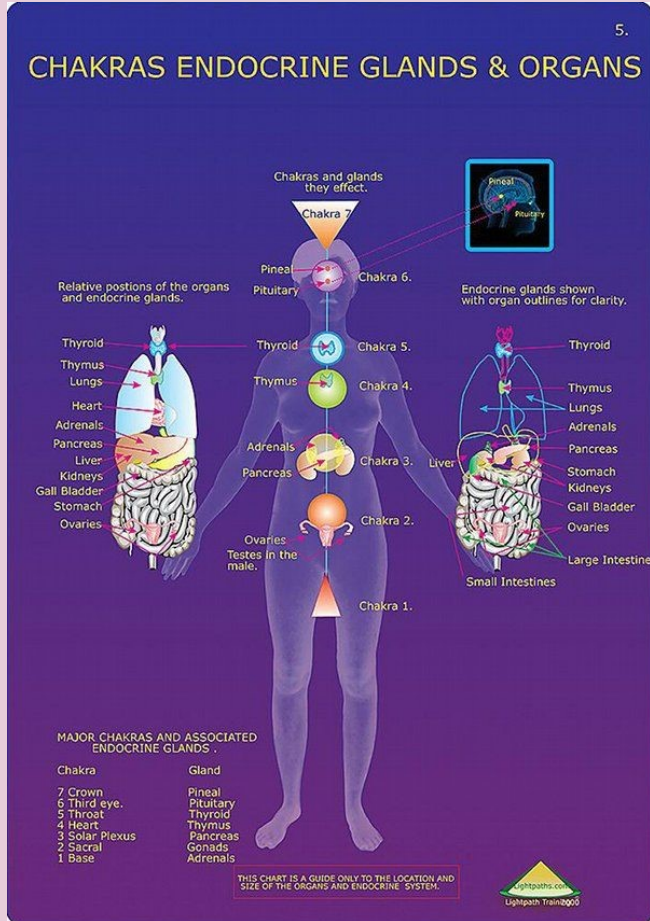

How Emotions Harm Your Body?

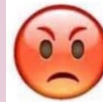

Anger weakens your liver.



Grief weakens your lungs.

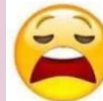

Worry weakens your stomach.



Stress weakens your heart and brain.



Fear weakens your kidney.



Chidhakarsha

To understand how to manage emotions and develop good health, register for the upcoming webinar on 9320077468 with your name and age

Feelings and Emotions travel in our body through the nerves.



Emotions that are uncontrolled gain



intensity and force over time, acting like



acid, corrupting and corroding the nerve



fibers which carry communication to the

brain from the organs

and from the brain to the organs.



Higher than the Mooladhara is the Svadhisthna or self-established. It is the seat of emotions. The cause of these emotions are the energies coming from the root chakra. Self-Importance combines with low energy and creates low self-esteem.



Higher than the Svadhisthana is the Manipura which has the power to redeem us from the toxic energies of the root chakra and control our emotions body too.

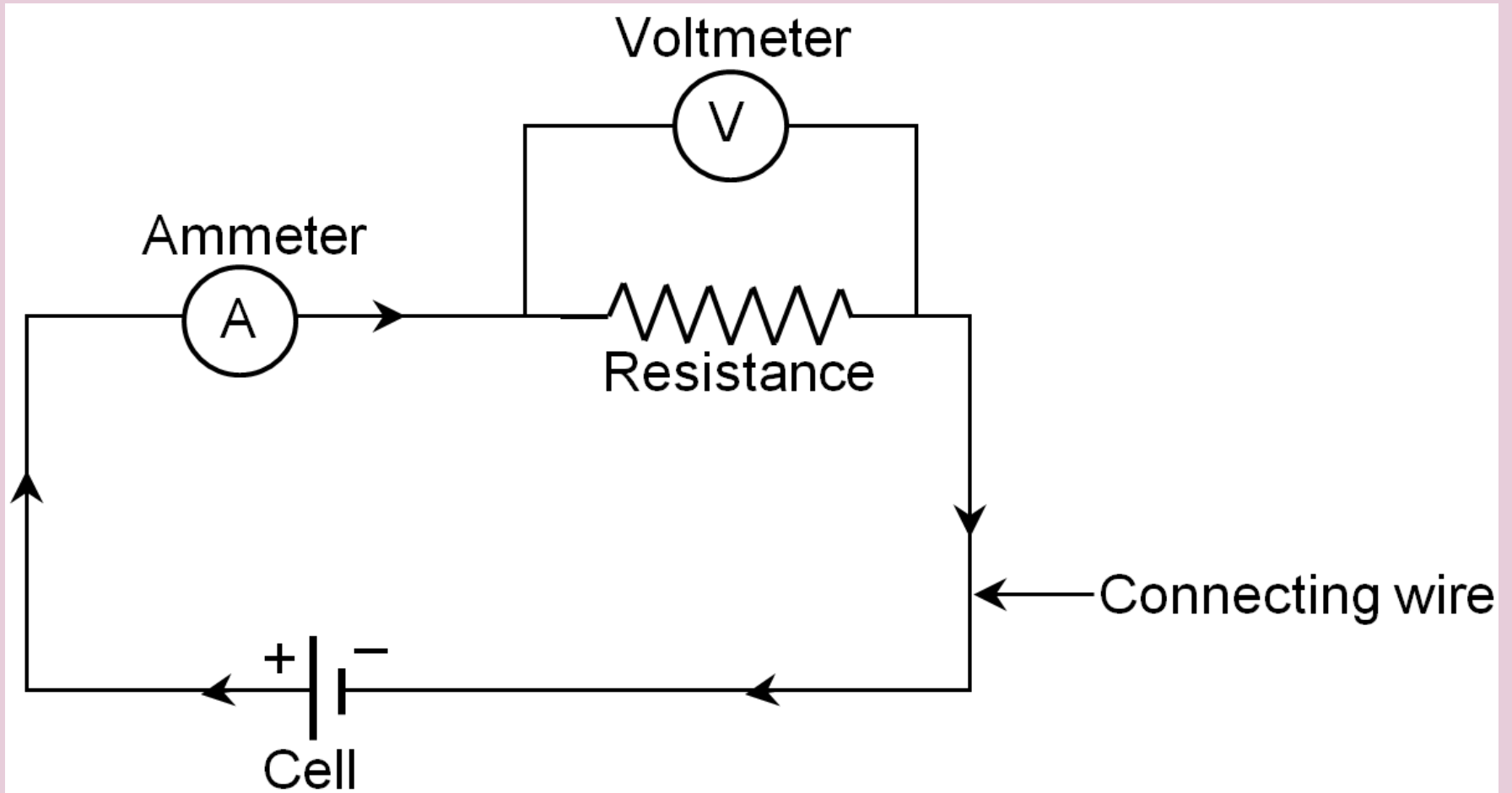



Energy and Association

Energy and Interconnectedness

Energy and Health

Energy and Mind

Energy and Nerves

Energy and Food

Energy and breath

Energy and Matter.