

INTEGRARACK®

Revolutionary Solar Racking Systems

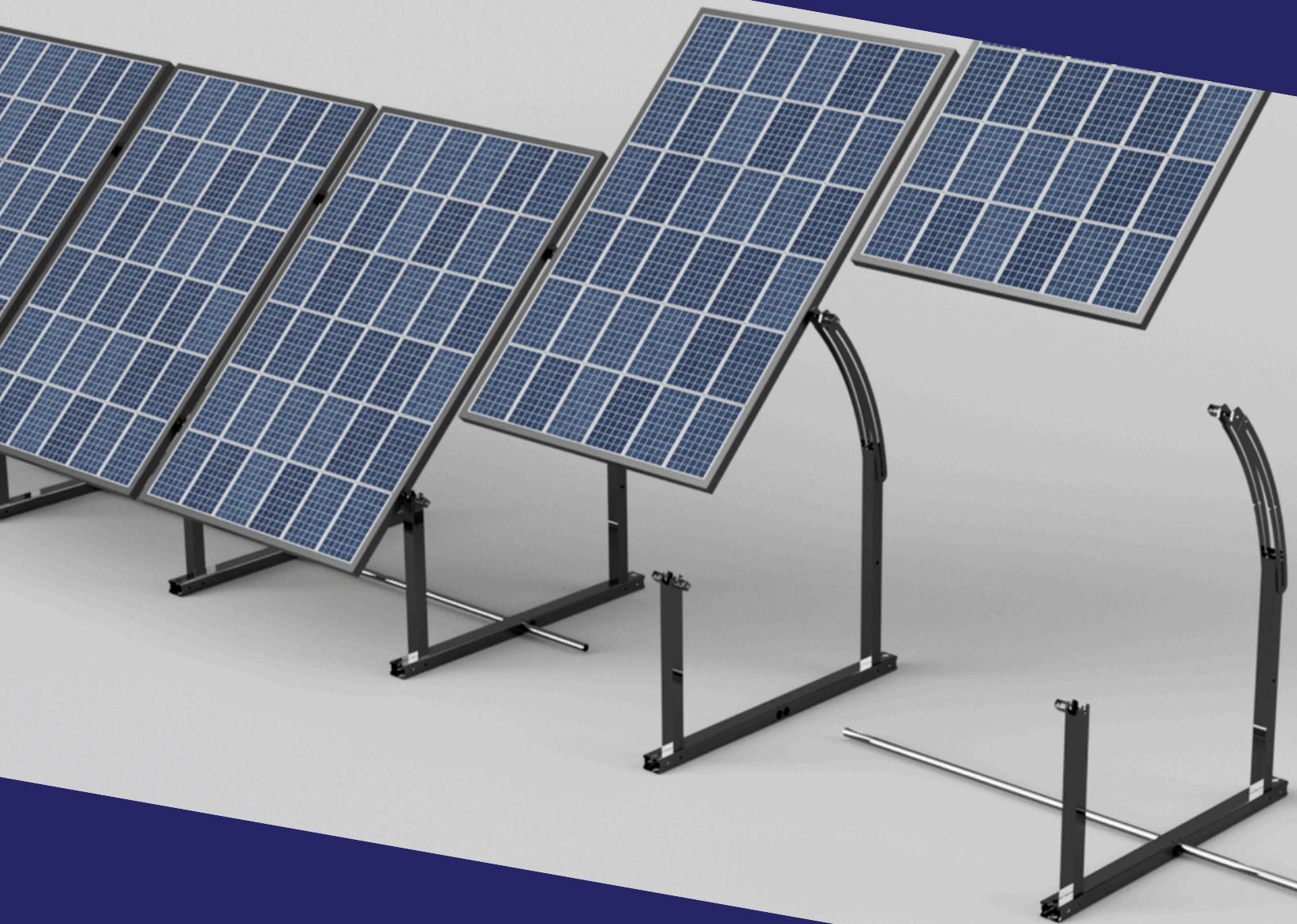

BallastRack Install Instructions

(IR-45ASAA / IR-45ASAB)

Warranty & Disclaimer	2
Mounting Options	3
Included Components & Required Tools	4
Mounting Kit Components & Required Tools	5
Assembly & Fastener Locations	6
Site Preparation & Row Spacing	7
Frame Assembly	8
Frame Spacing	9
IR EarthBallast™ Installation	10
IR EarthScrew™ Installation	13
IR AnchorSpike™ Installation	16
IR AnchorBolt™ Installation	19
Base Ballasted Installation	20
Installing Solar Modules	21
Adjusting The Sun Angle	22
Electrical Bonding & Grounding	24



IntegraRack® backs all of its products with a 25 year limited product warranty. We fully stand by the quality and guarantee that they will hold up under the harshest conditions when properly installed.

Disclaimer

The instructions detailed in this manual will provide the knowledge and requirements necessary for proper installation of the given product. Be sure to read them thoroughly and make sure that you fully understand them before proceeding with installation. Any improper use or installation of these products will void any and all warranty coverage, and may cause failure, property damage or personal injury. IntegraRack is not responsible for any damages caused by improper use. All IntegraRack products are only intended to be installed by professional, licensed installers.

IT IS THE RESPONSIBILITY OF THE INSTALLER TO:

- Comply with any and all applicable local or national codes and regulations.
- The installation methods shown in this manual are tested and approved for use by IntegraRack. Any other method for mounting will void the manufacture warranty.
- Ensure all products are appropriate for the installation according to the environmental and loading conditions.
- Ensure ground at installation site is level and suitable for the desired mounting.
- Disconnect AC power before servicing or removing modules, micro-inverters or power optimizers.
- Review manufacturer's documentation for compatibility and compliance for solar modules and 3rd party systems.
- If loose components or loose fasteners are found during periodic inspection, re-tighten immediately. Any components showing signs of corrosion or damage that compromise safety shall be replaced immediately.
- Provide an appropriate method of direct-to-earth grounding according to the latest edition of the National Electrical Code, including NEC 250: Grounding and Bonding, and NEC 690: Solar Photovoltaic Systems.
- Ensure safe installation of all electrical aspects of the solar system (All electrical installation and procedures should be conducted by a licensed and bonded electrician or solar contractor). Regular maintenance of a module or panel shall not involve breaking or disturbing the bonding path of the system. All work must comply with national, state and local installation procedures, product and safety standards.
- Ensure bare copper grounding wire does not contact aluminum and zinc-plated steel components, to prevent risk of galvanic corrosion.
- Ensure provided information is accurate. Issues resulting from inaccurate information are the installer's responsibility.

Mounting Options

IntegraRack® Mounting Kit Options

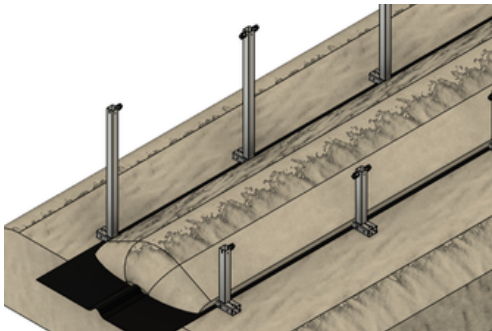

IR EarthBallast™ Kit

Part Number: IR-RFEB1071

Price: \$89.99

Our IR EarthBallast™ Kit comes with pre-cut rolls of strong Geotextile made for retaining walls and a high-strength fast setting epoxy to hold the Geotextile to the frames. This creates a large surface area to hold the dirt mound. See [Stamped Engineering & Datasheets](#) for your specific frame model to determine how much weight is needed per module section.

*3/4" round concrete forming steel stakes are recommended

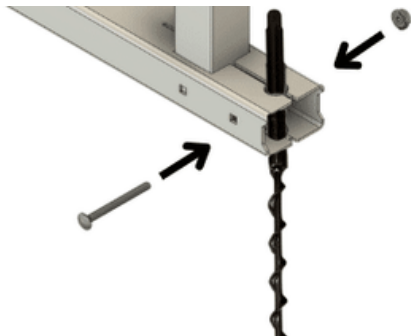

IR EarthScrew™ Kit

Part Number: IR-RFES3075

Price: \$129.99

Our IR EarthScrew™ Kit comes with specially designed 30" screws. Each IR EarthScrew Kit includes ten screws to install up to five frames. This kit provides fast and easy installation and leveling in almost any terrain with incredible strength.

*The IR EarthScrew is not recommended for silt/sand or rocky terrain, only dense compacted soil types.

*Each IR EarthScrew must be tested in soil at installation site to ensure they can withstand a minimum of 1,000 pounds of uplift.



IR SlabBallast™ Kit

Part Number: IR-RFCB1074

Price: \$59.99

Our IR SlabBallast™ Mounting Kit provides (22) concrete anchor bolts and (44) washers for the strongest possible mounting, and allows for easy installation of up to 10 solar modules. The frames can be direct bolted to pre-cast concrete footings or most existing concrete surfaces, such as patios and driveways (local site specific engineering required).

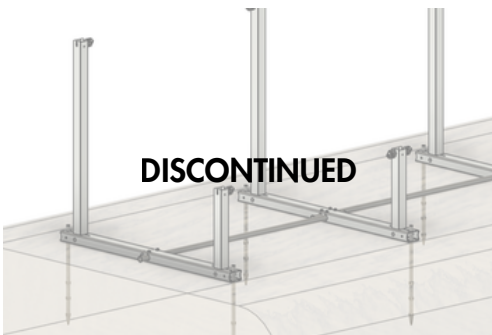

IR AnchorSpike™ Kit

10 Pack

Part Number: IR-RFAS0472

Price: \$144.99

22 Pack

Part Number: IR-RFAS1073

Price: \$299.99

Our IR AnchorSpike™ Kit comes with specially designed 30" barbed aluminum spikes, which have a hollow structure to allow our super strong two-part epoxy to flow deep into the soil and allows for fast and easy leveling of the system.

*The IR AnchorSpike is not recommended for silt/sand or rocky terrain, only dense compacted soil types.

*Each IR AnchorSpike must be tested in the soil at installation site to ensure they can withstand a minimum of 1,000 pounds of uplift.

Alternate Mounting Options

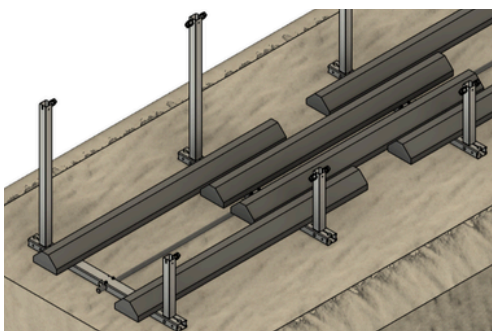

Base Ballast Mounting

Each BallastRack frame can be mounted using concrete curb stops, blocks, or sand bags for temporary or permanent mounting of solar modules.

*See [Stamped Engineering & Datasheets](#) for your specific frame model to determine how much weight is needed per module section.

*Ballast can be sourced locally (more info on Page 21).

*3/4" round concrete forming steel stakes are required

See our [Stamped Engineering & Datasheets](#) for product specific wind and snow load ratings

Included Components

IR-45ASA Components (Per Frame)

- (1) IR-45ASA Base Tube
- (1) IR-45ASA Adjustable Leg
- (1) IR-45ASA Short Leg
- (4) IR-F2 Flange Clamp Bonding Brackets
- (2) Washers (for IR-F2 clamps on short leg only)
- (4) Bolt As
- (4) Bolt Bs
- (4) Nut As

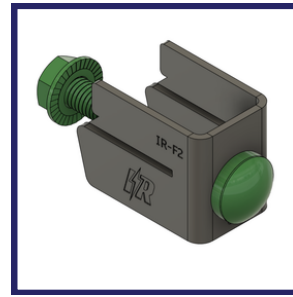

IR-F2 Solar Module Flange
Clamp Bonding Bracket



Washer

IR-45ASAB Components (Per Frame)

- (1) IR-45ASAB Base Tube
- (1) IR-45ASAB Adjustable Leg
- (1) IR-45ASAB Short Leg
- (4) IR-F2 Flange Clamp Bonding Brackets
- (2) Washers (for IR-F2 clamps on short leg only)
- (4) Bolt As
- (4) Bolt Bs
- (4) Nut As



Bolt A



Bolt B



Bolt C



Nut A

Required Tools

- Screw Gun with 1/2" Socket (**DO NOT USE AN IMPACT GUN**)
- Small 1/2" or 13mm Wrench (**NOT INCLUDED WITH BALLASTTRACK FRAMES**)
- Cut-Resistant Work Gloves
- 4' Level
- Tape Measure
- String Line
- 3/4" Round Concrete Forming Stakes (**OPTIONAL**)

Required Additional Materials

- 1" EMT (Electrical Metal Tubing) / Conduit Pipe (Can be sourced at most local hardware stores; NOT required for concrete mounting)
- IlSCO SGB-4 Dual Rated Solar Grounding Lug

Mounting Kit Components



IR EarthBallast Kit

- Quick Cure 15 Epoxy Resin
- Extra Mixing Nozzle
- 3' x 50' Roll of Geotextile Material
- Alcohol Wipes
- Scuff Sponge
- 13mm Ratchet Wrench (For BallastRack Assembly)

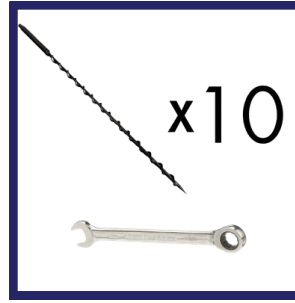

IR EarthScrew Kit

- (10) IR EarthScrews
- 13mm Ratchet Wrench (For BallastRack Assembly)



IR AnchorSpike Kit

- (10/22) IR AnchorSpikes
- Epoxy Resin A
- Epoxy Resin B
- Mixing Cup
- 3oz Measuring Cups
- Stirring Stick
- Funnel
- Gloves
- 13mm Ratchet Wrench (For BallastRack Assembly)



IR AnchorBolt Kit

- (22) 3/8" Concrete Anchor Bolts
- (44) Washers
- (2) 3/8" Concrete Drill Bits
- 13mm Ratchet Wrench (For BallastRack Assembly)

Additional Tools Required For Mounting Kits

IR EarthBallast Kit

- Caulk Gun
- Shovel

OPTIONAL

- Skid-Steer Loader
- 3/4" Round Concrete Forming Steel Stakes

IR EarthScrew Kit

- Powerful 3/8" Drive Impact Wrench Gun or Standard 1/2" Drive Impact Wrench Gun
- 14mm Socket
- Dirt Tamper
- 3/4" Locking Shaft Collars (one for each EarthScrew mounted at the rear of the rack frame; can be sourced at Amazon, Ebay, or other large hardware suppliers)

OPTIONAL

- SDS Max Hammer Drill
- 1x30" SDS Concrete Drill Bit
- Portland Cement Powder
- Eggbeater Style Cement Mixer
- 12-3/4 x 23-1/4" Vinyl Grout Bags
- Funnel

IR AnchorSpike Kit

- Small Sledge Hammer
- SDS Plus Hammer Drill
- 3/4" x 30" SDS Concrete Drill Bit

IR SlabBallast Kit

- SDS Plus Hammer Drill
- 9/16" (14mm) Deep Socket
- Line Chalk

Assembly & Fastener Locations

⚠ CAUTION:
Laser cut parts may have sharp edges; Handle with care and always wear cut resistant work gloves.

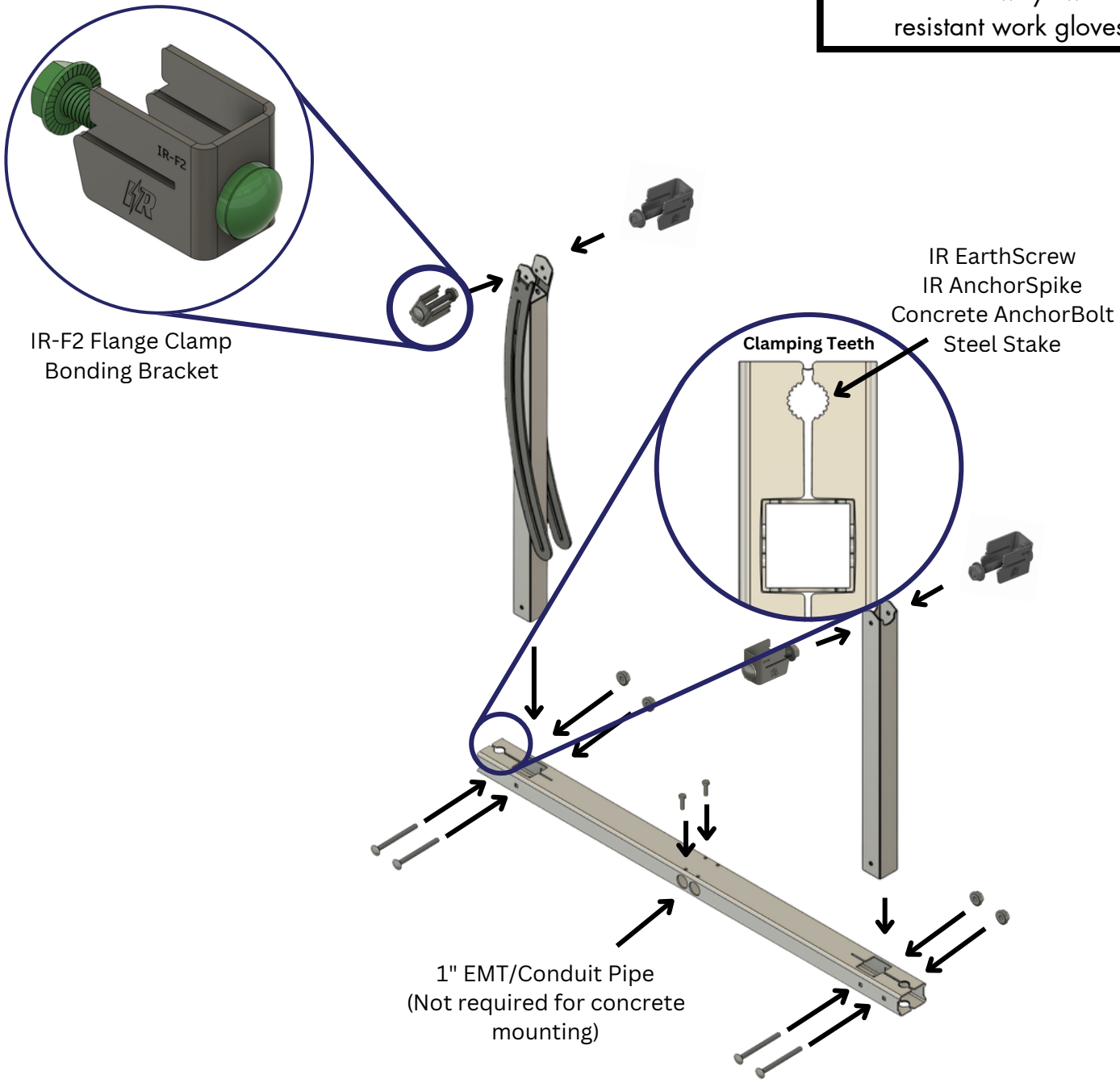

Site Preparation

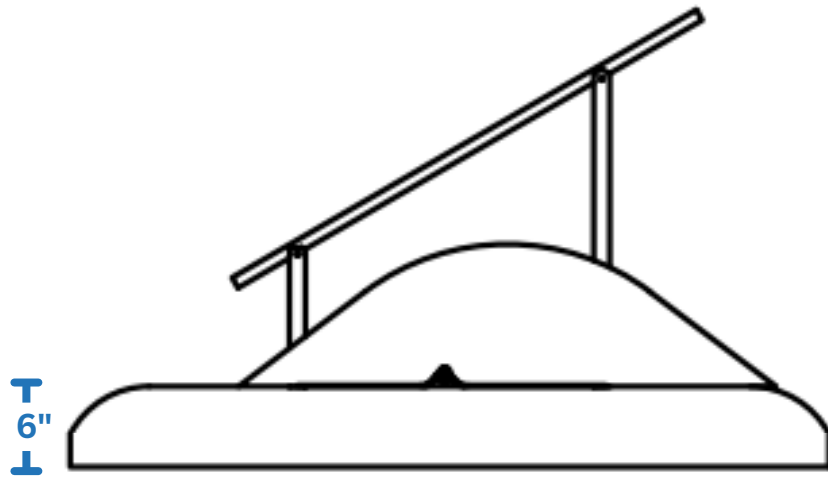

Leveling The Ground

Ensure that the ground at the installation site is as level as possible prior to installation of your BallastRack frames. It is recommended to bring in 6" of extra soil to compact such as road base type material to increase the ground clearance under your solar panels. This elevated pad should be 4.5 - 5' wide for the entire length of the solar array section.

Ensure that the ground at installation site is as level as possible prior to installation.

Maximum Slope

North/South

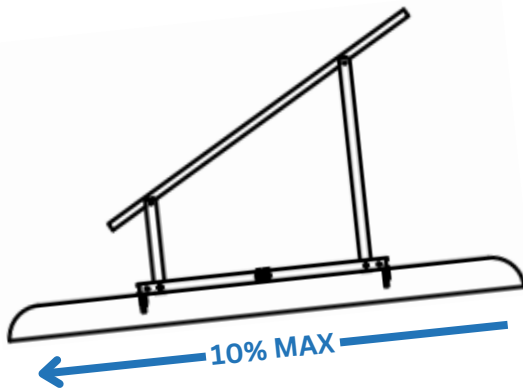

East/West

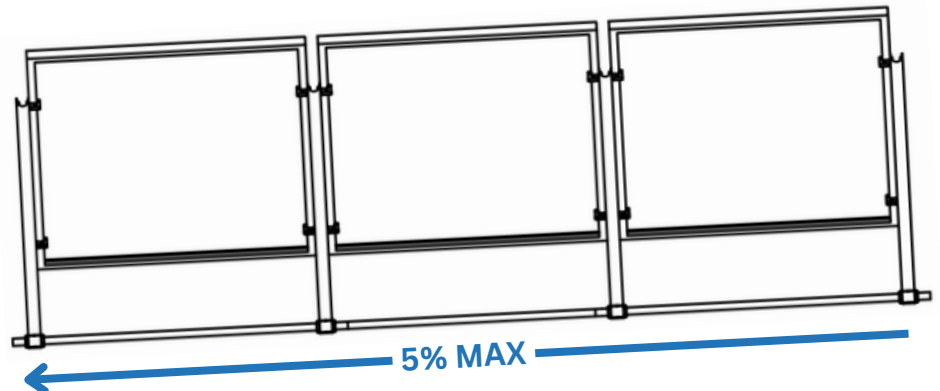

Row Spacing

Row spacing can vary substantially based on terrain elevation, solar panel size being utilized, and the region of the world where the solar array is being installed. Please check with a local solar designer to calculate the exact space needed from row to row.

IMPORTANT

- Make sure to leave the system locked in the lowest position until full installation is complete.
- Despite the recommended torque ratings, some torque wrenches can be inaccurate, and you should stop tightening if the rack frame starts to bend or deform.

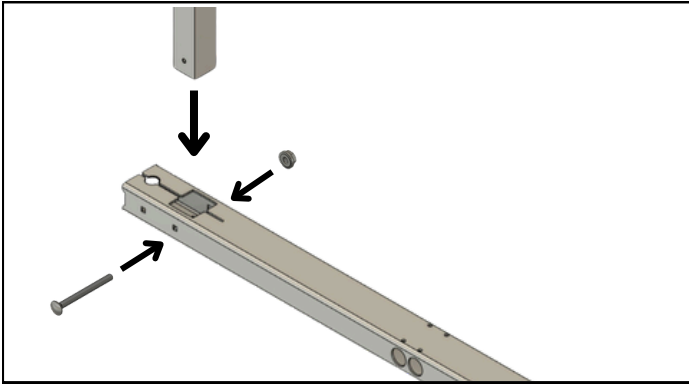

Figure 1

1. Install The Long Leg

Insert the long leg into the square opening at the back of the base tube and make sure the bottom of the adjustable arm is pointed towards the front of the base tube. Use a single Bolt A and Nut A to lock it in place.

***Leg retention bolts require 10 ft lbs of torque**

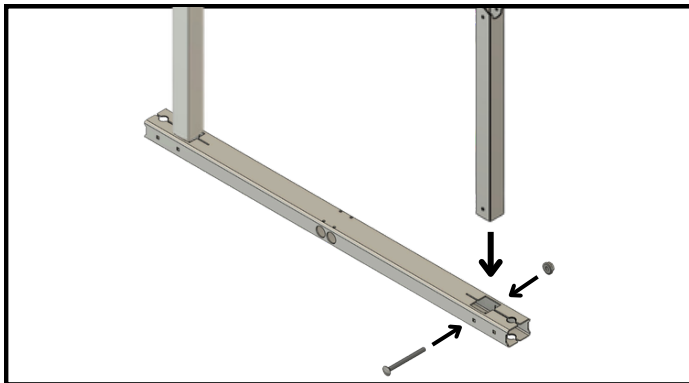

Figure 2

2. Install The Short Leg

Use the same process to install the short leg, making sure that the holes for the solar panel clamps are facing the sides of the base tube.

Repeat Steps 1 & 2 until all frames are assembled.

***Leg retention bolts require 10 ft lbs of torque**

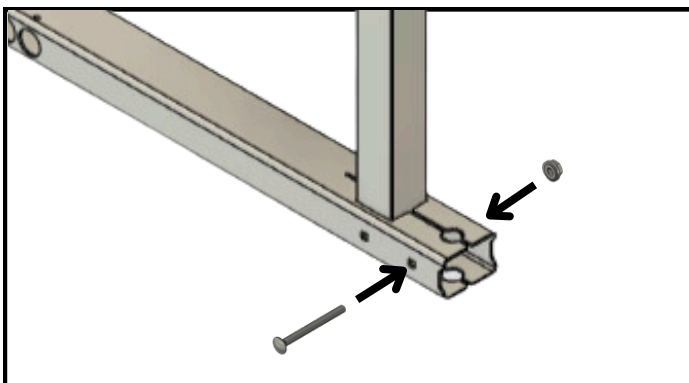

Figure 3

FOR DIRECT BOLTED INSTALL ONLY

If you are direct bolting your system to concrete, use the remaining Bolt As to clamp the ends of each base tube (See Figure 3) and skip to **Page 19** for installation.

***End clamp bolts require 10 ft lbs of torque**

⚠ IMPORTANT

- If direct bolting this system to a concrete surface or otherwise, skip to **Page 19**.
- Make sure to measure the space in between the base tubes and not in between the legs for frame spacing. Always measure along the conduit pipe for accurate spacing.
- Screw gun is required for self threading Bolt Bs. Be careful not to strip the bolts and only loosen them again if necessary.
- PRO TIP: You can cut a 2x4 to your spacing measurement for easy spacing of the frames (it is important to place the 2x4 against the EMT or as close to center as possible).

SPACE BETWEEN FRAMES

IR-45ASA (Aluminum)

(Solar Panel Width) minus 1"

IR-45ASAB (Black Steel)

(Solar Panel Width) minus 3/4"

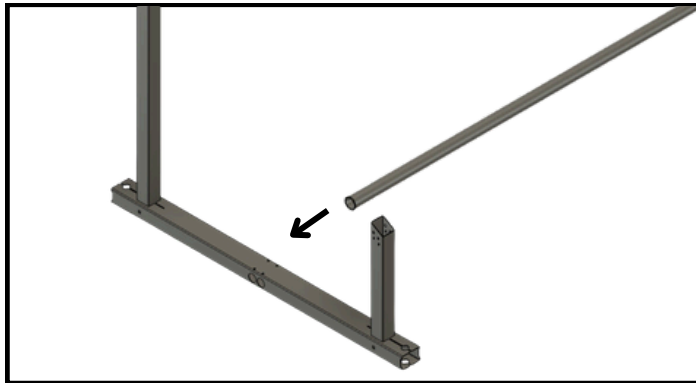

Figure 4

3. Insert 1" EMT/Conduit Pipe

Once all frames are assembled, place one at the start of the row and insert the conduit pipe into one of the openings in the side of the base tube (See Figure 4). Slide the pipe all the way through, but leave at least 2" extra on each end of the system.

1" conduit pipe NOT required for concrete mounting

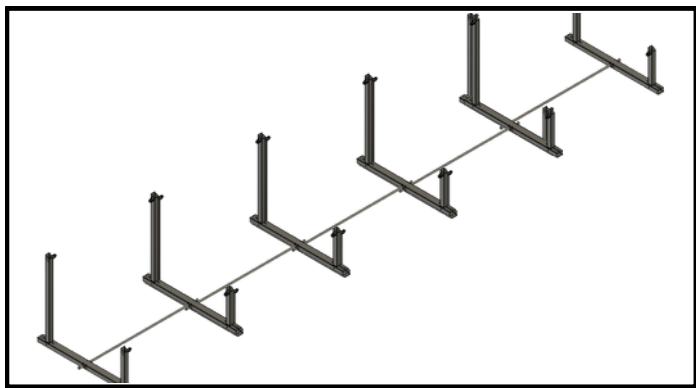

Figure 5

4. Spacing Frames Apart

Slide the next frame along the conduit pipe and space them roughly where they will need to be according to your solar module's width (make sure the conduit pipe goes through the same opening on each frame). Once the end of the first conduit pipe is reached, insert the next conduit pipe through the other opening on the last frame (See Figure 6). Repeat this until all frames are connect by the conduit pipes and are spaced roughly to your solar module's width.

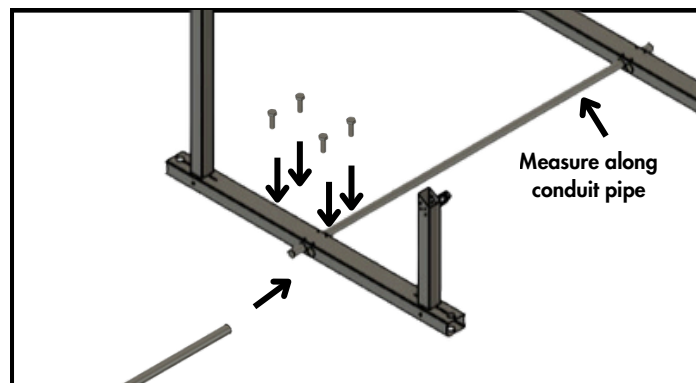

Figure 6

5. Lock Frames In Place

The frames must be spaced the width of your solar panel minus 1" (IR-45ASAB: solar panel width minus 3/4"). Be sure to measure in between the base tubes along the conduit pipe for most accurate spacing. Slide the frames along the conduit pipe and use a screw gun to insert all Bolt Bs into the top of base tubes to lock frames in position. Only two bolts are required per frame except for frames that are connected to two conduit pipes, which require four Bolt Bs (See Figure 6). *No cutting or coupling of the conduit pipe is required.*

Leveling Frames

⚠ IMPORTANT

- Even when placing frames on pre-leveled ground, there can still be some irregularities in the frame system. Before leveling the system, it is important to make sure that all frames are lined up in straight rows using a string line.
- After lining up the frames, stakes can be hammered in place at the front and back of each frame. Stakes are optional, but recommended to keep system in line and for assisting with leveling the frames.

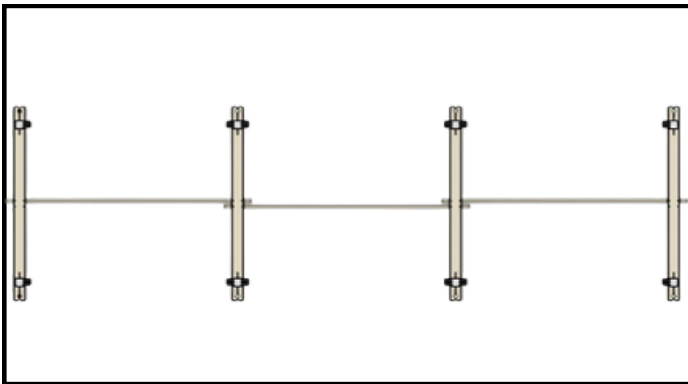

Figure 7

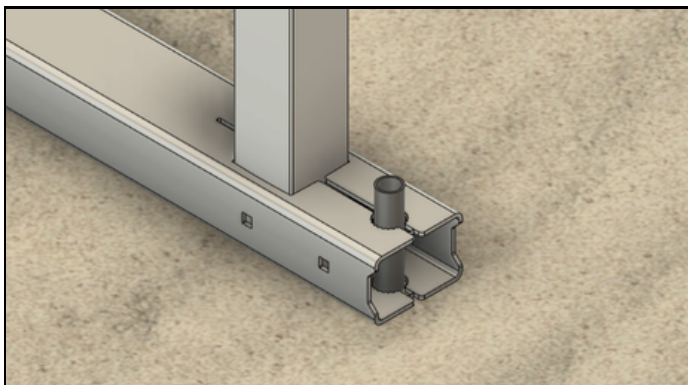

Figure 8

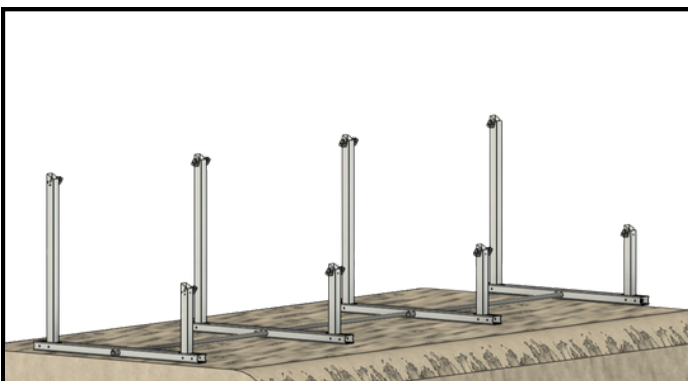

Figure 9

BALLAST WEIGHT REQUIREMENTS

To see the specific weight requirements for your chosen BallastRack Model, view our [Stamped Engineering & Datasheets](#)

1. Line Up The Frames

Run a string line from the long leg of the first frame, stretch it along the frame system to the long leg of the last frame. Adjust the system as necessary until all frames are aligned with the stringline.

2. Place Steel Stakes

Concrete forming steel stakes provide fast and easy leveling as well as added racking strength to the entire system while keeping all of the frames in line. Use a small mallet to hammer concrete stakes into the ground through the stake openings at the end of each base tube. Each base tube can now be leveled using a level/stringline and clamped to the stakes by tightening the bolts at the end of each base tube.

3. Leveling The Frames

Tie a string line from one end of the row to the other. Then, raise the end frames until they are level with each other and higher than all other frames. If there is a high spot in the middle of the row, remove dirt from under that frame so it is below the end frames. Raise all frames up to the string line and clamp them to the stakes to keep them level (see steps 3-4 on page 15). Now, use a shovel to pack dirt underneath the frames to support them at this new height.

Attaching Geotextile

⚠️ IMPORTANT

- It is important to properly prep the top surface of each base tube using the scuff pads and alcohol wipes included with the IR EarthBallast Kit before applying the epoxy adhesive.
- Keep in mind that the epoxy will set up in 15 minutes, so be sure to roll the geotextile along the way as the epoxy is applied.
- Always extend the geotextile fabric 2 feet beyond each end of every row and make sure all of the material is buried.

System Three Technical Specs



Minimum Application Temp.: 40°F (4°C)

Minimum Storage Temp.: 40°F (4°C)

Cure Time: 12 Minutes at 70°F (21°C)

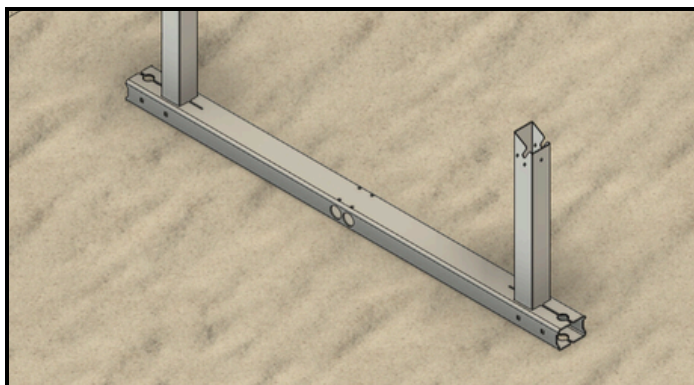

Figure 10

4. Prep Adhesive Surface

Use the included scuff pad to scuff the top of each base tube to remove the surface layer of oxidization and to promote better adhesion. Just before applying the epoxy, clean the surface using the provided alcohol wipes.

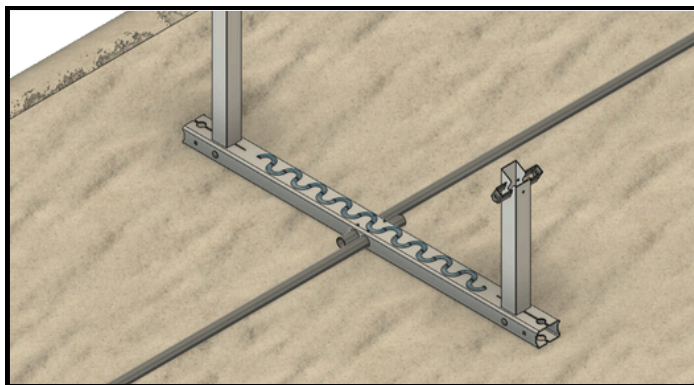

Figure 11

5. Apply Adhesive

Remove the twist cap and pull the sealing plug from the included epoxy and attach the mixing nozzle. Using a caulk gun, apply the epoxy in a zig zag pattern along the top of each base tube in between the two upright legs (See Figure 11).

It is important to note that epoxy only requires 15 minutes to set up, so larger installations may require rolling the Geotextile Material after every 10-12 frames have had the epoxy applied to them.

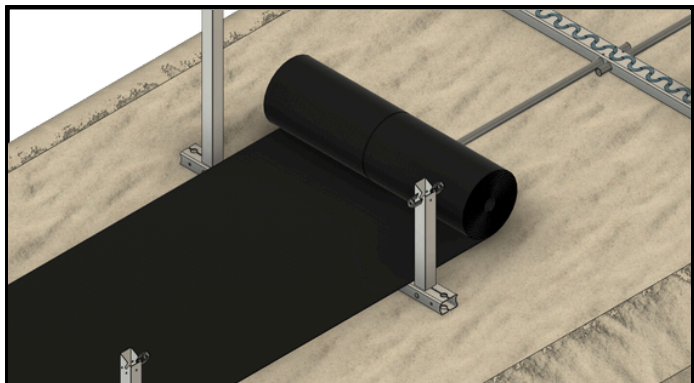

Figure 12

6. Roll Out The Geotextile Material

Secure the first 2 feet of the geotextile roll with weights or rocks ahead of the first frame and pull lightly while unrolling it across the top of the wet epoxy. Keep light tension between each frame section before pulling the material down onto each frame. Before epoxy sets up, use rubber gloves to lightly rub the geotextile material into the wet epoxy before the 15 minutes has lapsed. Extend the geotextile 2 feet beyond the end of the row.

Earth Filling Frames

⚠️ IMPORTANT

- It is recommended to determine the weight of the soil being used for ballasting, to determine how much is needed. Please see our [Engineering & Datasheets](#) for specific weight requirements for the IR-45ASA.
- It is best to use compactable soil for ballast system as loose soil or sand may be displaced by high winds.
- Earth mound should be uniform in shape and size across the entire system to ensure even ballasting.
- Ensure highest point of the earth mound is slightly closer to the long legs for better weight distribution.



Figure 13

7. Earth Fill Frames

Using a shovel or a skid-steer, dump a pile of material onto the geotextile fabric in between each frame. Please see our [Engineering & Datasheets](#) for specific weight requirements for the IR-45ASA. *Repeat this step until every frame is covered.*



Figure 14

8. Pack The Earth Mound

Use a shovel to pack the earth mound down and form it with a shovel/rack into a uniform shape. Make sure the center of the mound is closer to long legs for better weight distribution.



Figure 15

Proceed To Page 21 For Module Installation

⚠️ IMPORTANT

- Not for use in silt/sand soil types and not recommended for rocky soil.
- The IR EarthScrew system is only recommended for frost depths of up to 20".
- It is recommended to test a single IR EarthScrew in the soil at installation site to ensure at least 1,000 pounds of uplift.

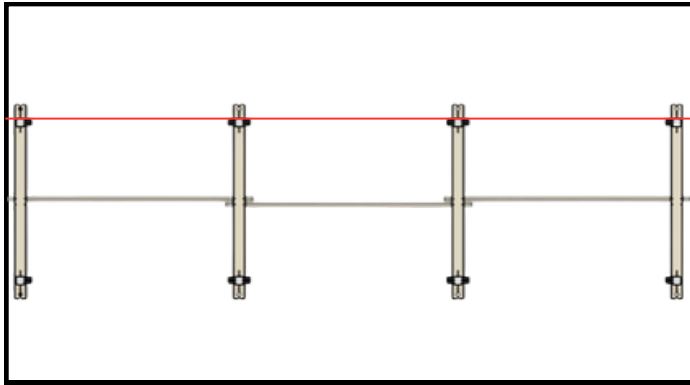

Figure 16

1. Line Up The Frames

String line at the base of the front or rear leg on one end of the row and run it along the row of BallastRack frames to line them up. Leave the string line attached for leveling after install.

Optional Installation Steps - For dense/rocky soil types

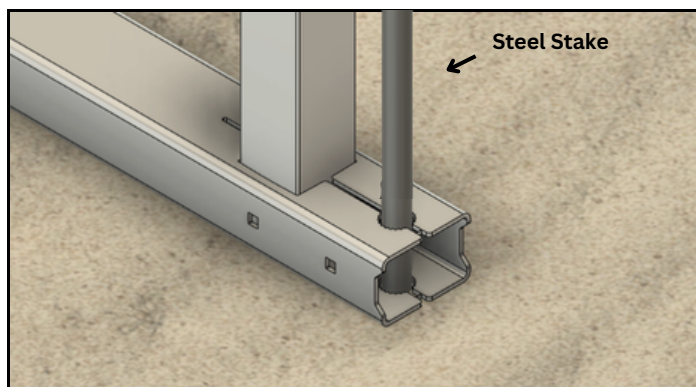

Figure 17

Mark Drilling Locations

Using a steel stake, tap it 1-2" into the ground through the open holes at each end of the base tube to mark the ground for the EarthScrew pre-drilling locations.

*It is best to wet the ground before marking drilling locations

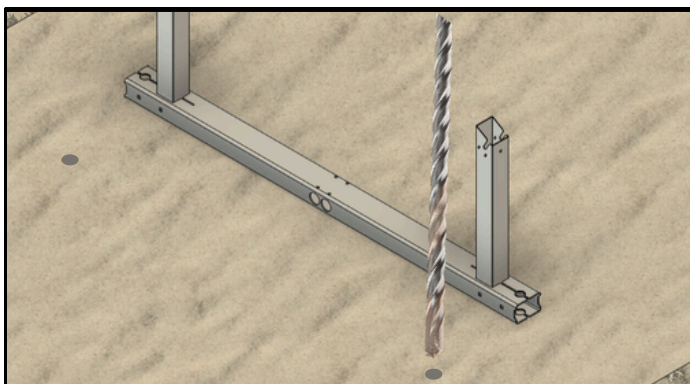

Figure 18

Drill Holes For The IR EarthScrews

Move the entire system 3-4" left or right so the holes can be drilled with the frames out of the way. Use an SDS Max Hammer Drill and a 1x30" SDS Concrete Drill Bit to drill a hole 20-24" deep at each of the marked locations.

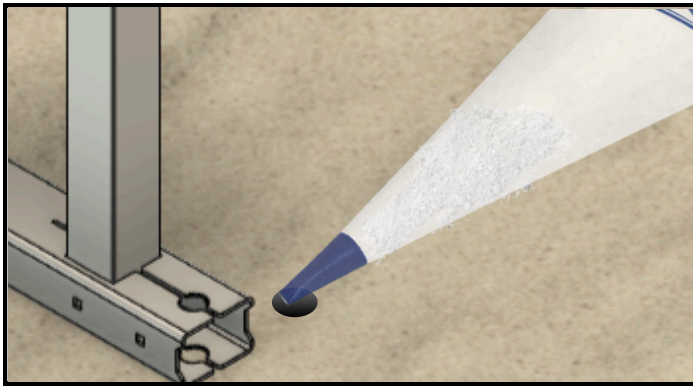

Figure 19

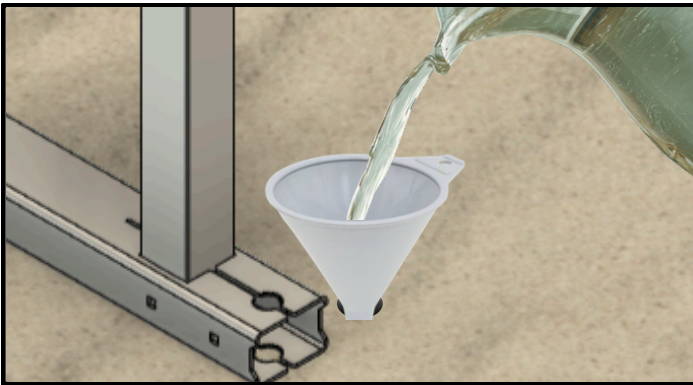

Figure 20

Fill With Water & Portland Cement

Use a funnel to pour 8oz of water into each hole, then use a grout bag to fill each hole with Portland Cement Powder until about 1" from the top. Much of the water will be forced out as the cement powder goes in.

Installing The EarthScrews



Figure 21

2. Install the EarthScrews

Use a powerful $\frac{3}{8}$ " drive impact wrench gun or a standard $\frac{1}{2}$ " drive impact wrench gun with a 14mm socket to screw the EarthScrews into the ground through the opening at the end of each base tube. Screw in until 6" of smooth shank is above the soil ground level.

BallastRack frames can be placed back in position before or after this step.

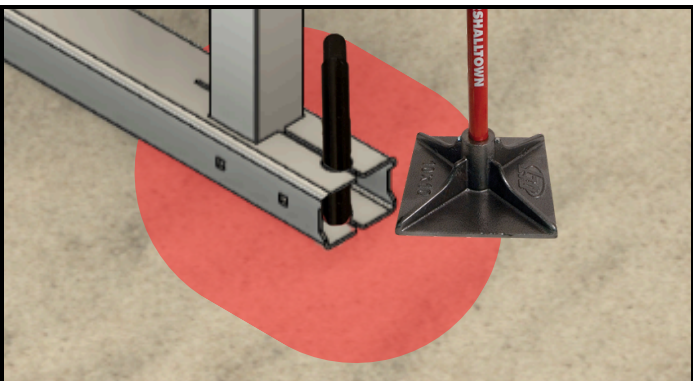

Figure 22

3. Compact The Soil

Berm up the area around the screws and fill with water. Once the water has been fully absorbed and the surface has dried, use a dirt tamper to compact the soil around each screw.

If testing for pullout strength, wait 7-10 days for the soil to fully solidify.

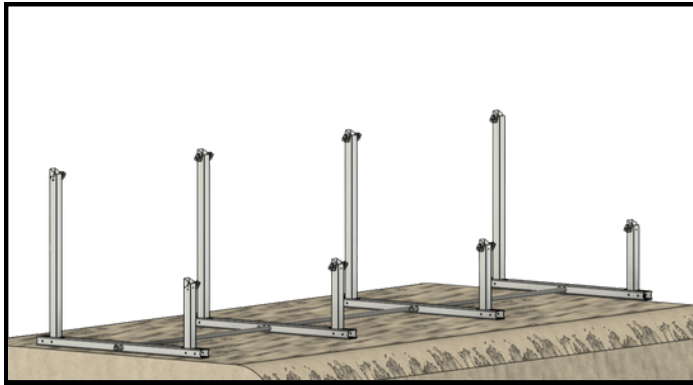

Figure 23

3.Leveling The Frames

To level the frames, the two end-of-row BallastRack frames need to be slightly higher before you level. Now bring the middle frames up to the string line and lock them in place in the next step.

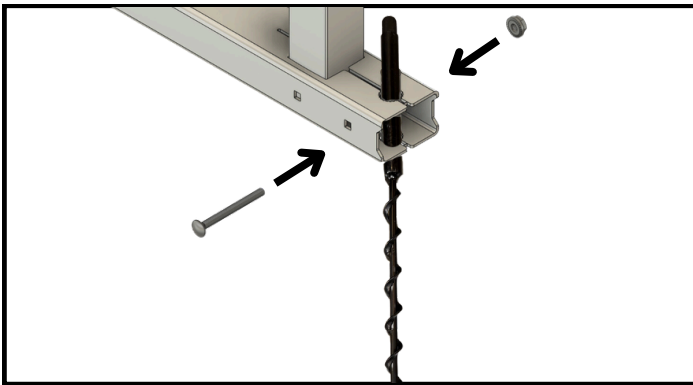

Figure 24

4.Clamp The EarthScrews

Each BallastRack frame has a clamp built into each end of the base tube and small teeth that will bite into the EarthScrew when the second bolt is tightened. Once the frame is level, insert and tighten the second Bolt A to clamp the ends and lock the base tube in a level position (See Figure 24).

***End clamp bolts require 10 ft lbs of torque**

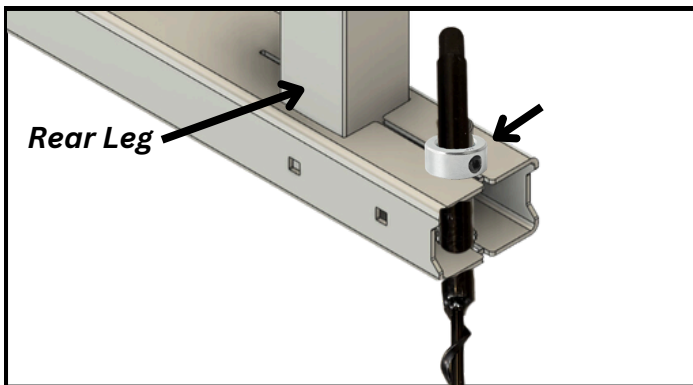

Figure 25

5.Install The Locking Shaft Collars

3/4" locking shaft collars must be installed on each EarthScrew at the rear of each rack frame near the long leg, and can be sourced at Amazon, Ebay, or other large hardware suppliers.

***Not required for AnchorSpikes**



Figure 26

Proceed To Page 21 For Module Installation

Drilling Holes For IR AnchorSpikes

⚠ IMPORTANT

- Ensure that soil is compacted otherwise IR AnchorSpikes will not be as effective.
- The IR AnchorSpike system is only recommended for frost depths of up to 18".
- It is recommended to test a single IR AnchorSpike in the soil at the installation site to ensure to ensure that they can withstand the proper amount of uplift (see our Stamped Engineering & Datasheets).
- Make sure to drill holes as straight as possible.

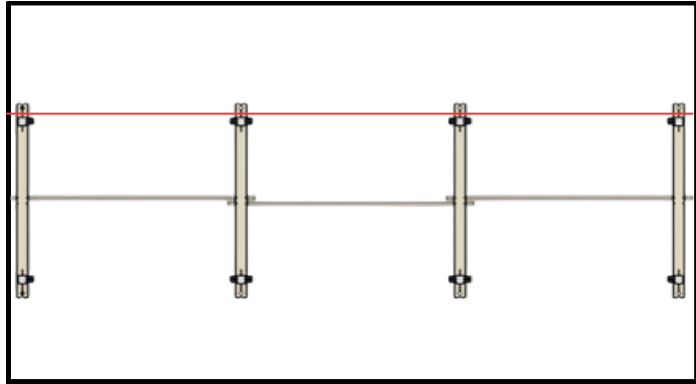

Figure 27

1. Line Up The Frames

Run a string line from the long leg of the first frame, stretch it along the frame system to the long leg of the last frame. Adjust the system as necessary until all frames are aligned with the stringline.

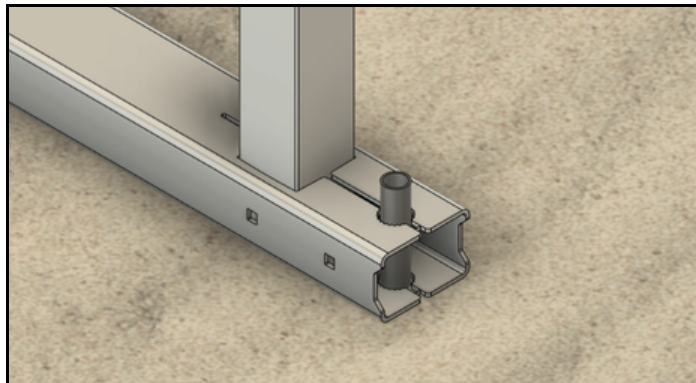

Figure 28

2. Mark Drilling Locations

Hammer one of the AnchorSpikes 1-2" into the ground through the open holes at each end of the base tube and remove it to mark the ground for the AnchorSpike pre-drilling locations.

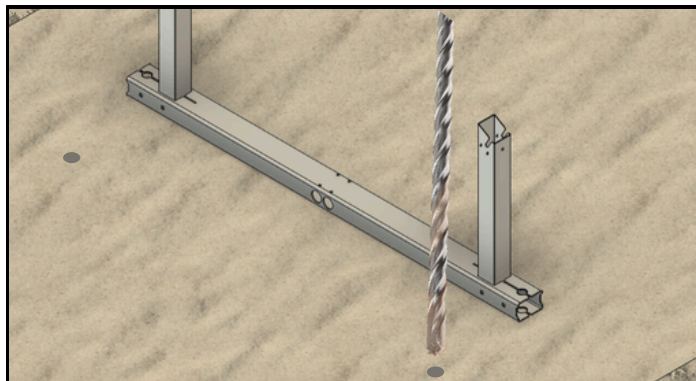

Figure 29

3. Drill Holes For IR AnchorSpikes

Move the entire system 2-3" left or right so the holes can be drilled with the frames out of the way for drilling. Using an SDS Hammer Drill and a 3/4" x 30" SDS Concrete Drill Bit to drill a hole that is at least 26" deep at each of the marked locations.

Installing IR AnchorSpike

IMPORTANT

- Make sure to thoroughly mix the two part epoxy for the recommended time.
- It is important to not fill measuring cup more than 1/4" (6mm) from the top.
- Epoxy takes approximately 8 hours to set up.
- Wear the provided rubber gloves to avoid getting epoxy on skin.



Figure 30

4. Installing The AnchorSpike

Use a hammer to tap the AnchorSpike into the pre-drilled holes. Be sure to leave approximately 6-8" of the spike above ground for easy leveling later on. Lift up the BallastRack frames and slide them onto the AnchorSpike (See Figure 30).



Figure 31

5. Mixing The Epoxy

Pour the A and B Epoxy components into the provided mixing container and stir for 2-3 minutes with the included stirring stick.

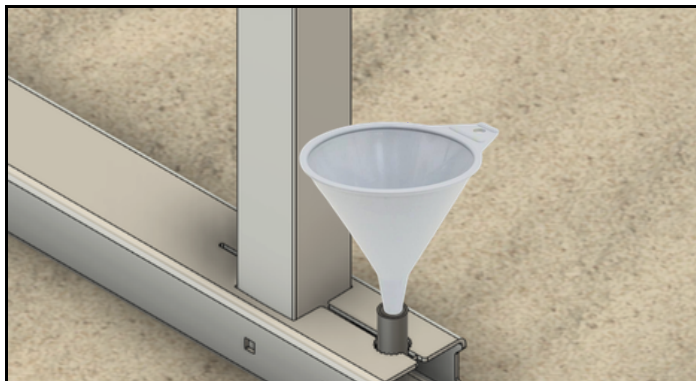

Figure 32

6. Pour The Epoxy Into The IR AnchorSpike

Pour the mixed epoxy into the small measuring cup 1/4" (6mm) down from the top (be careful not to fill more than necessary). Now pour the epoxy through the top of each IR AnchorSpike and wait 8-10 hours for the epoxy to harden before proceeding to the next step.

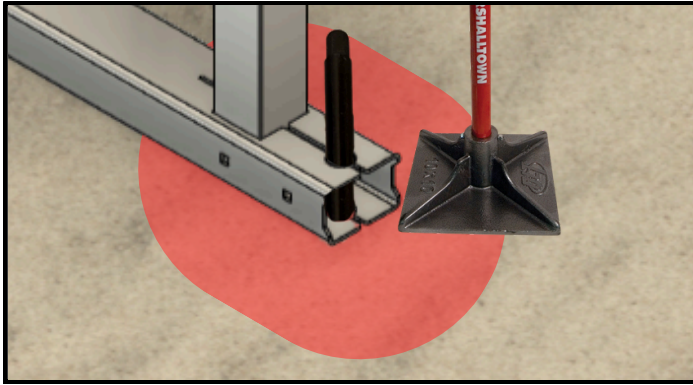

Figure 33

7. Compact The Soil

Wait 24 hours for epoxy to fully cure, then wet the soil around each AnchorSpike and wait 30 minutes for the water to absorb into the soil, then tamp the soil with a dirt tamper.

If testing for pullout strength, wait 7-10 days for the soil to fully solidify.

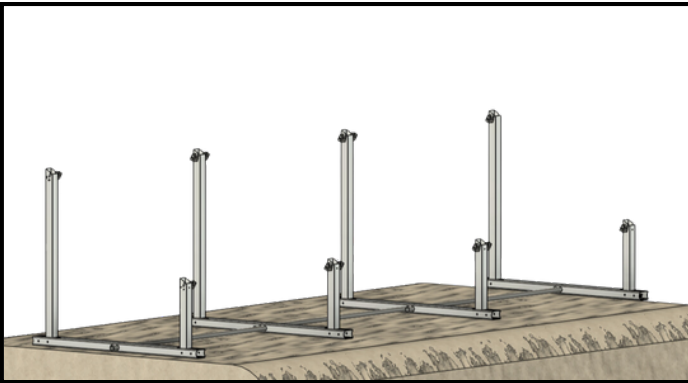

Figure 34

8. Leveling Frames

The easiest way to level the system is to run a string line along the tops of the base tubes and bring them all up to the string line. Level each frame one at a time and clamp the base tubes to the AnchorSpike to keep them level. Once level, proceed to the next step.

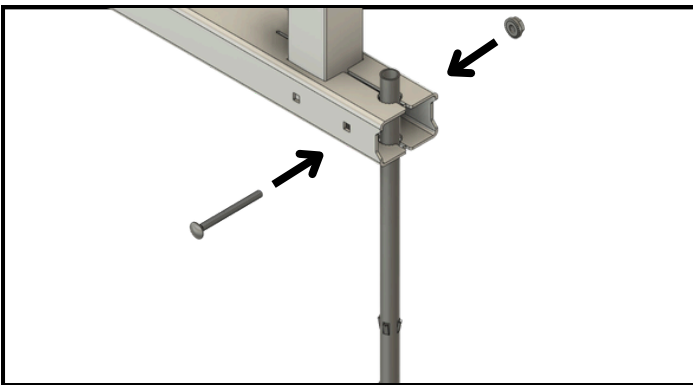

Figure 35

9. Clamp AnchorSpike

Each BallastRack frame has a clamp built into each end of the base tube and small teeth that will bite into the AnchorSpike when the second bolt is tightened. Once the frame is level, insert and tighten the second Bolt A to clamp the ends and lock the base tube in a level position (See Figure 35).

****End clamp bolts require 10 ft lbs of torque***



Figure 36

Proceed To Page 21 For Module Installation

Measuring & Installation

⚠ IMPORTANT

- Make sure to measure the space in between the base tubes and not in between the legs for frame spacing.

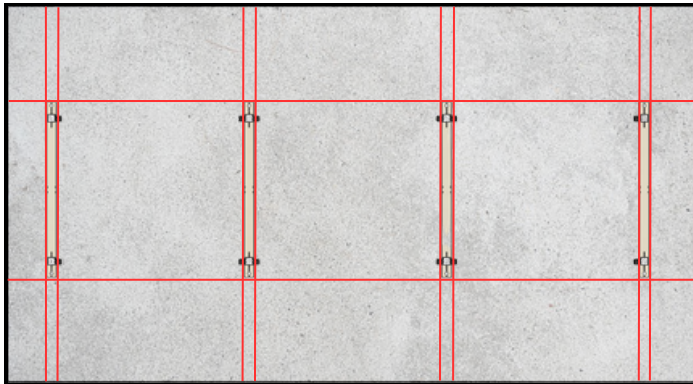

Figure 37

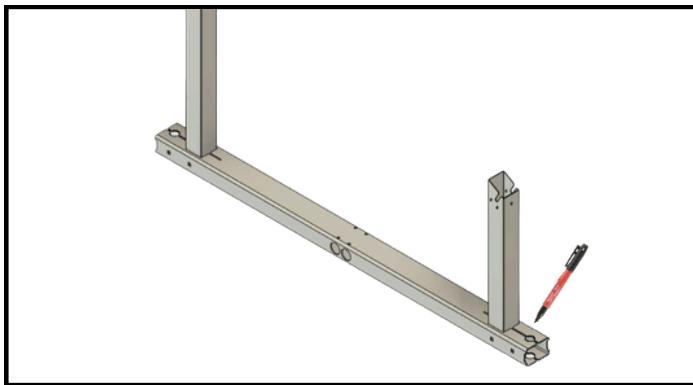

Figure 38

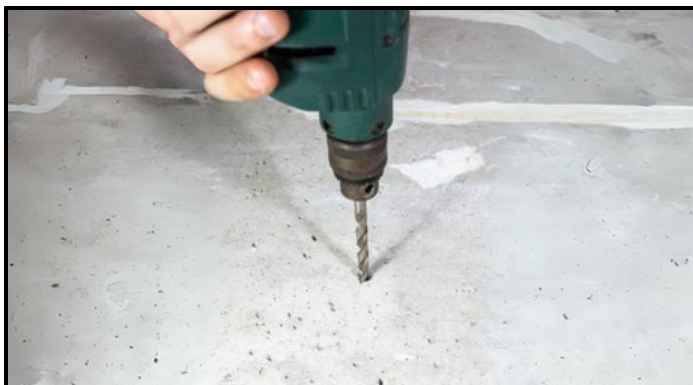

Figure 39

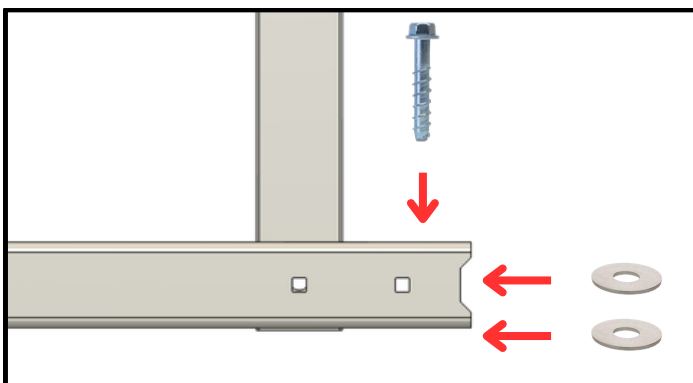

Figure 40

1. Measure & Chalkline Frame Placement

The frames must be spaced according to the width of your solar panels (See Page 10, Step 5). Place all frames at the exact spacing and mark both sides of each base tube. Make sure the frames at each end of the row are lined up straight and mark from the first frame to the last frame and chalk a line in between (See Figure 37).

2. Mark The Drilling Locations

Move each frame into their marked positions and use a permanent marker to outline the opening at the end of each base tube where the concrete anchor bolts will go into the concrete.

3. Drill Pilot Holes

Move all frames out of the way and use an SDS Hammer Drill and the included concrete drill bit to drill a 3" deep hole in the middle each of the marked locations on the concrete.

4. Bolt The Frames To The Concrete

Move all frames back into their marked locations, and bolt them in place using the provided concrete anchor bolts and washers. Make sure to place one washer under the base tube and one under directly under the head of the bolt (See Figure 40).

IMPORTANT

- Round 3/4" concrete forming steel stakes are required for this mounting option to prevent movement of system.



Ballasting Options

The IntegraRack BallastRack system can be ballasted using concrete curb stops, cinder blocks, or sandbags. Make sure to follow the requirements below:

- Ensure that the minimum weight requirement is met for your chosen racking system (see [Engineering & Datasheets](#) for model specific weight requirements)
- Ensure that the ballasted weight is distributed evenly across the length of the system
- Treated lumber can be laid across the base tubes of the frame to support sand bags or cinder blocks
- This mounting option is not recommended in high-wind areas

IMPORTANT

- The IR-45ASA requires a washer for each clamp attached to the short legs of the frame.
- Solar module height can be adjusted after mounting by sliding them along the flange clamps before tightening serrated nuts.
- Have IR-F2 Flange Clamp Bonding Brackets readily available before placing modules for fast mounting.
- The flange of the module will fit into the slot cut into the side of the IR-F2 and the pointed barbs should be inside the flange for bonding of the modules.
- Make sure to remove the serrated nut before placing the IR-F2 clamp onto the flange of the solar panel.

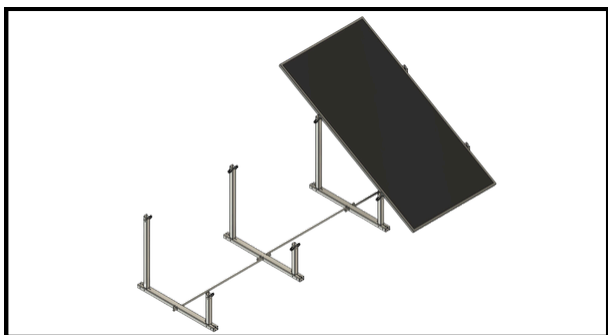

Figure 41

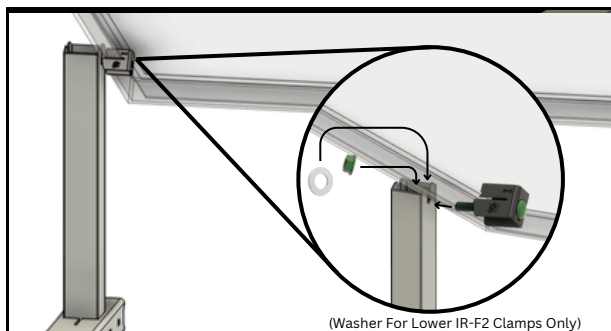

Figure 42

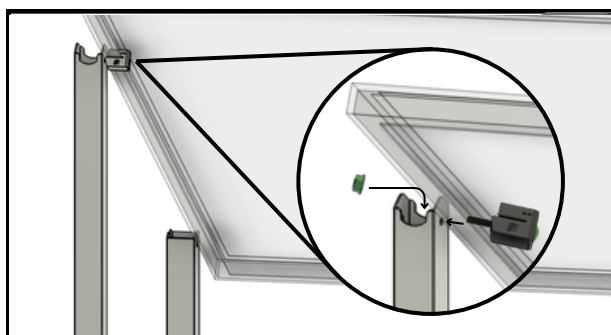

Figure 43

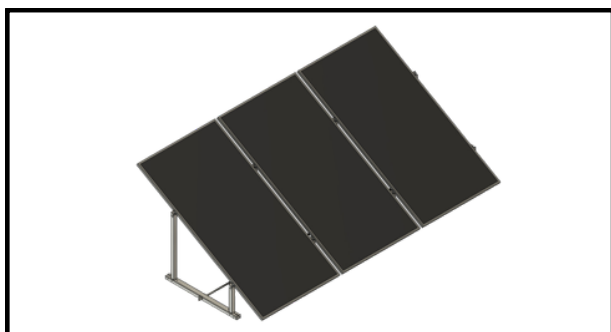

Figure 44

1. Position The First Solar Module

Remove the serrated nuts from the end of each IR-F2 Clamp and keep them readily available for mounting. Carry solar module and place it into position between the the first two frames. Set the module roughly where it will be mounted.

2. Mount Lower IR-F2 Brackets

Lift up the bottom of the solar module to the top of the short legs and attach the lower IR-F2 Clamps in similar fashion to the upper clamps. If washers are included with your frame, the lower clamps will require a washer for easier rotation during angle adjustment. Insert the bolt into the opening, fasten the included washer and nut onto the end of the bolt, and tighten by hand for now. Repeat on both sides.

3. Mount Upper IR-F2 Brackets

Now lift the top of the solar module to the top of the long legs of the frames and get ready to place the IR-F2 Clamp on one side of the module. Slide the clamp onto the flange of the panel, insert the bolt through the opening at the top of the tall leg, and fastened the nut onto the end of the bolt and tighten by hand for now. Repeat this process on the other side of the panel.

4. Adjust Solar Module Height

Once all solar modules are in place, they can be slid up and down to ensure that they are all the same height for a clean looking system. The serrated nuts may need to be loosened before doing so. Simply slide the modules to the desired position and use the ratchet wrench included with your base mounting kit to tighten all of the serrated nuts and lock the modules in place. If you did not purchase a mounting kit most 1/2" or 13mm wrenches will work provided they are small enough to fit in between the bolts. Make sure not to over-tighten.

***IR-F2 clamps require 10 ft lbs of torque**

Adjusting The Sun Angle

Sun Angle Markings

The image below shows the entire assembly of the adjustable leg for each IR-45ASA. You can see that each Adjustable Angle Plate is marked every 5° to help you set it to the desired angle. The following page will explain how to adjust the sun angle for each panel now that they are mounted.

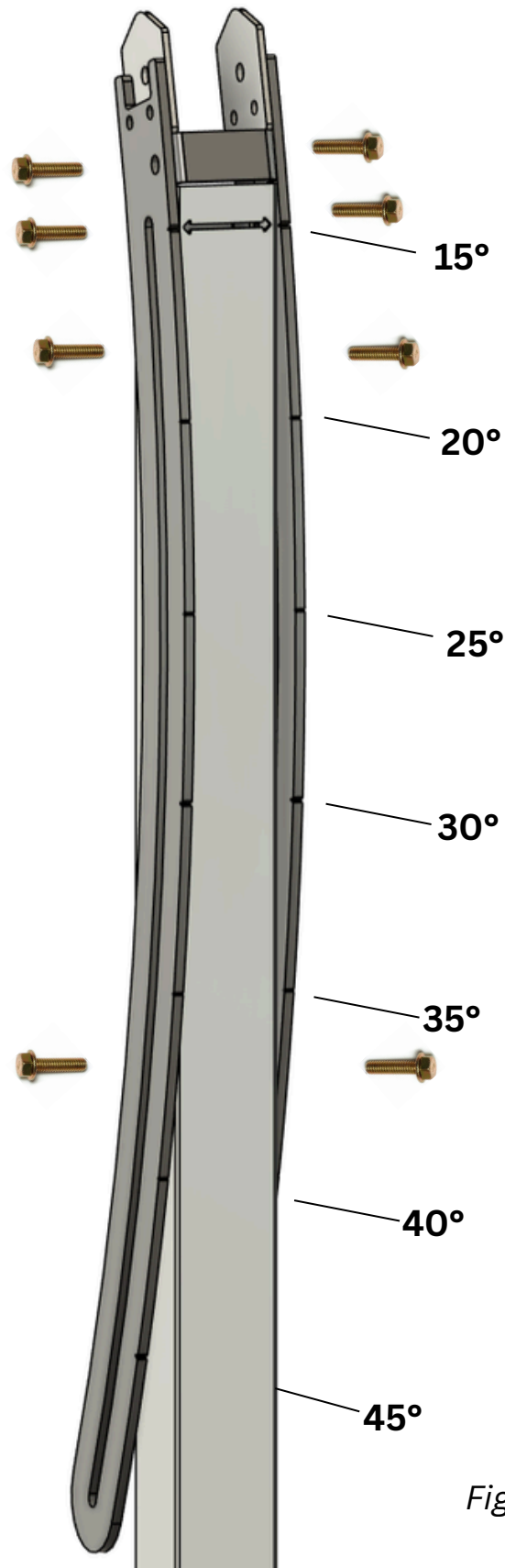

Figure 45

Adjusting The Sun Angle

IMPORTANT

- Before adjusting the system, you will need to remove the coupler bolted in between the panels and safety bolts currently fastened near the bottom of the adjustable arms.
- There is no need to remove the other four bolts, as the adjustable arms are meant to slide along these bolts.
- Do NOT forget to reattach the coupler after setting the sun angle.

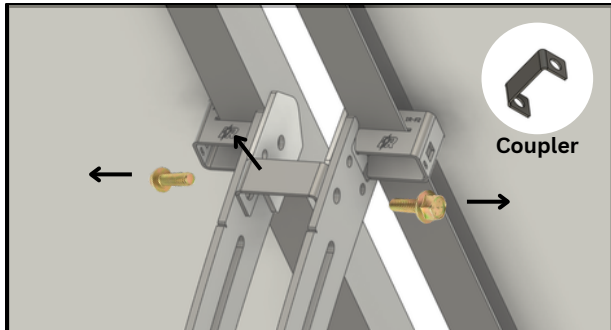

Figure 46

1. Remove The Couplers

Before you can adjust each panel independently, use a screw gun or wrench to remove the coupler in between the two adjustable arms of each frame.

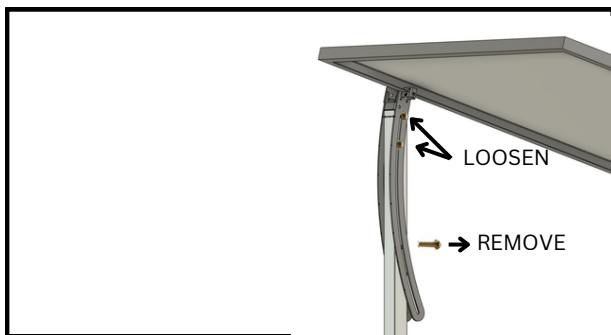

Figure 47

2. Adjust The Sun Angle

Each adjustable arm is attached to the leg by three Bolt Ds. The lowest bolts will need to be removed to slide the arm to its maximum height. Using one hand to hold the panel, use a screw gun to loosen both of the upper bolts on each side. You can now adjust the angle of the panel freely.

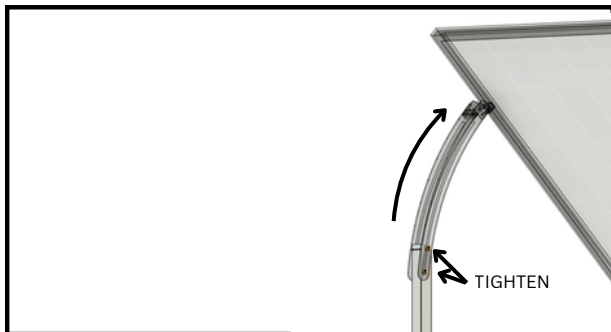

Figure 48

3. Setting The Sun Angle

Each frame should be set at 15° when you take it out of the box. Slide it up and find the desired angle using the notches on the back of the adjustable arms. Each notch represents a 5° increment from 15°-45°. Align the desired angle marker with the arrows on the leg and tighten the upper bolts.

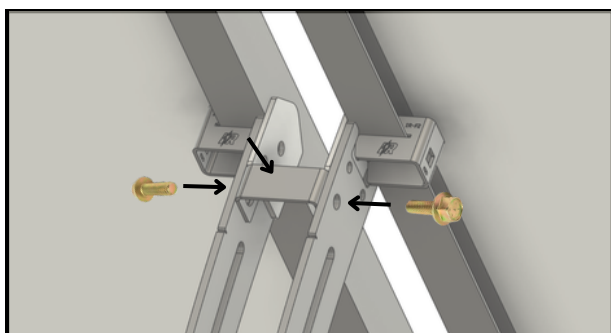

Figure 49

4. Reattach The Couplers

Once you have finished adjusting your panels, be sure to reattach the couplers. All panels must be set to the same angle to attach the couplers.

Electrical Bonding & Grounding

IntegraRack® IR-F2 Solar Panel Clamp



The IR-F2 uses sharp piercing barbs to penetrate the frame of the solar panel and create a bonding path.

*As per UL 2703, the BallastRack railless solar panel racking system is not part of the electrical bonding/grounding pathway.

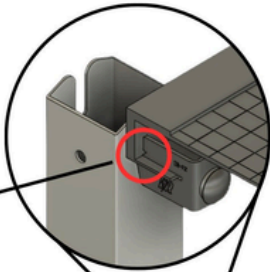

IntegraRack IR-F2 solar panel clamps provide great bonding from solar panel to solar panel, but if full UL 2703 compliance is required for the project, 8" DynoRaxx® DynoBond™ Bonding Jumpers can be used as shown.

Ground mount frames are excluded from the bonding pathway according to UL 2703, therefore, DynoBond bonding jumpers are all that is required to fully comply with UL 2703 electrical bonding requirements for our rail-less solar panel mounting systems.

DynoRaxx® DynoBond™ Bonding Jumper (8 Inch)

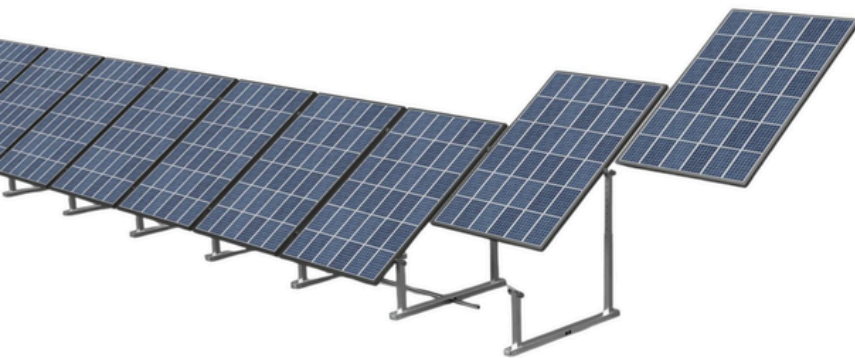
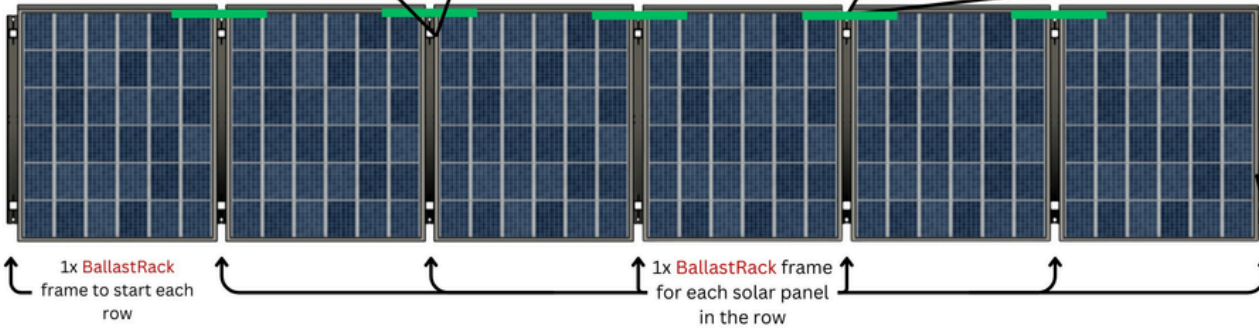
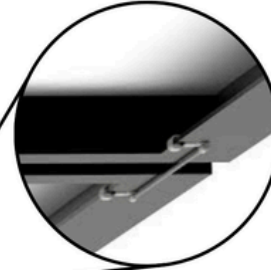

One grounding lug (Ilco SGB-4 Dual Rated Solar Grounding Lug) will need to be clamped to the inner flange of the solar panel frame at one end of each row installed.

Run heavy gauge copper wire from the grounding lug to the systems grounding rod.



**Always check local building codes for proper earth grounding procedures*

Click [HERE](#) to download UL Certificate for DynoBond Bonding Jumpers

IR-F2 Flange Clamp Bonding Bracket

INTEGRATED ZIP TIE SLOT FOR WIRE MANAGEMENT

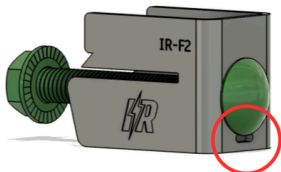

Integrated Wire Management

When using the integrated wire management with the IR BallastRack system, it is best to run your wires near the front legs with enough slack for the panels to move freely during seasonal adjustment.

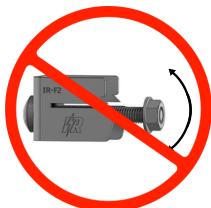

Pre-Inspection of IR-F2 Clamps

Before installing or re-installing any IR-F2 clamps, always check to make sure that the bolt is tightened properly. If the bolt is able to move in any way, the inner nut must be re-tightened.



More IR-45ASA Info



**See Our Other
Revolutionary Products**



©IntegraRack 2024, All Rights Reserved. Multiple US Patents Pending

www.IntegraRack.com