

INTEGRARACK®

Revolutionary Solar Racking Systems

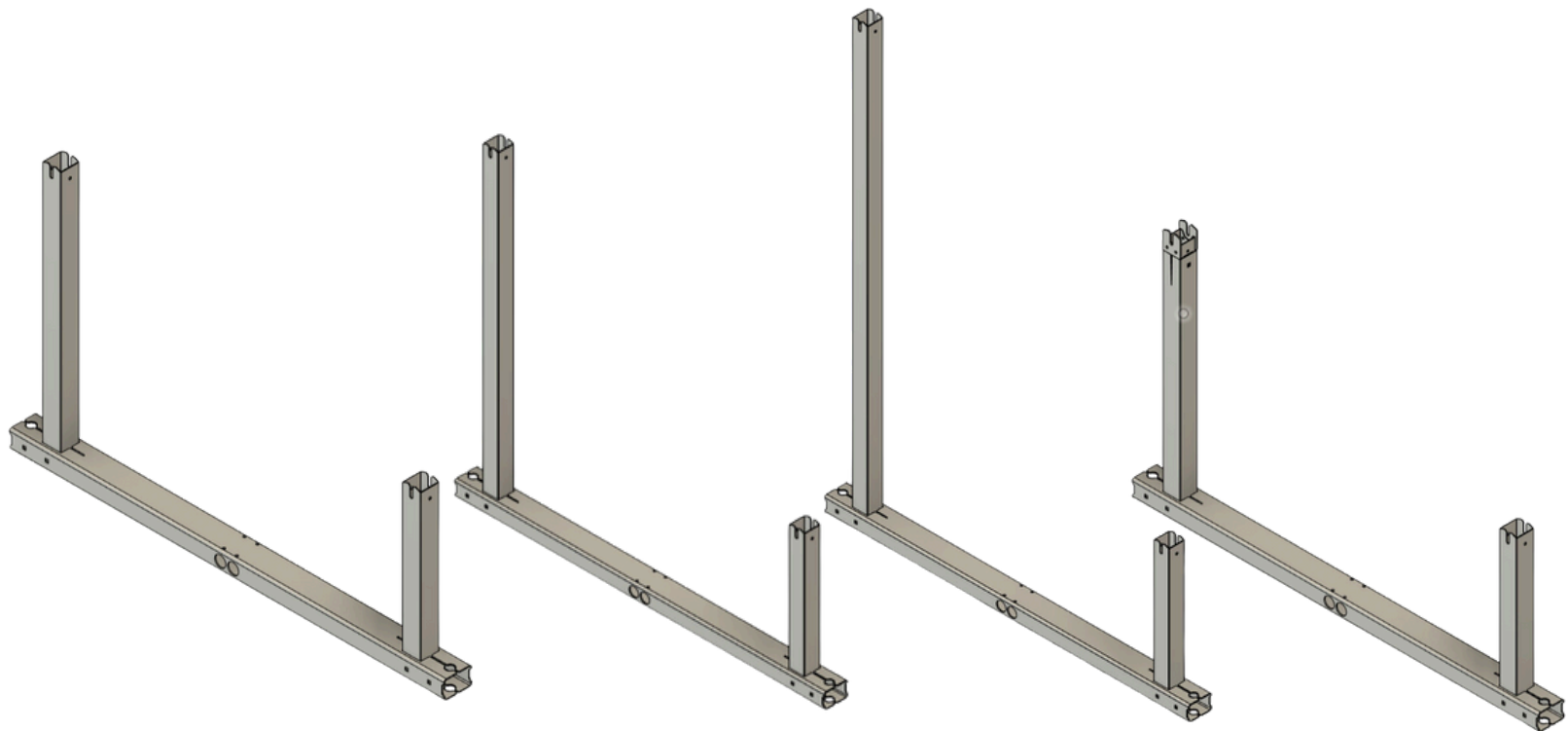

IR-15,30,45,35A INSTALL INSTRUCTIONS

Contents

Warranty & Disclaimer	2
Planning Layout	3
IR Frame Models	4
Mounting Options	5
Components & Required Tools	6
Assembly & Fastener Locations	8
Mounting Kit Components & Required Tools	9
Frame Assembly	10
Frame Spacing	11
IR EarthBallast™ Installation	12
IR AnchorSpike™ Installation	15
Concrete Slab/Footing Lag Bolt Installation	18
Base Ballast Installation	19
IR-35A - Adjusting The Sun Angle	20
Installing Solar Modules	21



IntegraRack® backs all of its products with a 25 year limited product warranty. We fully stand by the quality and guarantee that they will hold up under the harshest conditions when properly installed.

Disclaimer

The instructions detailed in this manual will provide the knowledge and requirements necessary for proper installation of the given product. Be sure to read them thoroughly and make sure that you fully understand them before proceeding with installation. Any improper use or installation of these products will void any and all warranty coverage, and may cause failure, property damage or personal injury. IntegraRack is not responsible for any damages caused by improper use.

IT IS THE RESPONSIBILITY OF THE INSTALLER TO:

- Comply with any and all applicable local or national codes and regulations.
- Ensure all products are appropriate for the installation according to the environmental and loading conditions.
- Ensure ground at installation site is level and suitable for the desired mounting.
- Disconnect AC power before servicing or removing modules, micro-inverters or power optimizers.
- Review manufacturer's documentation for compatibility and compliance for solar modules and 3rd party systems.
- If loose components or loose fasteners are found during periodic inspection, re-tighten immediately. Any components showing signs of corrosion or damage that compromise safety shall be replaced immediately.
- Provide an appropriate method of direct-to-earth grounding according to the latest edition of the National Electrical Code, including NEC 250: Grounding and Bonding, and NEC 690: Solar Photovoltaic Systems.
- Ensure safe installation of all electrical aspects of the solar system (All electrical installation and procedures should be conducted by a licensed and bonded electrician or solar contractor). Regular maintenance of a module or panel shall not involve breaking or disturbing the bonding path of the system. All work must comply with national, state and local installation procedures, product and safety standards.
- Ensure bare copper grounding wire does not contact aluminum and zinc-plated steel components, to prevent risk of galvanic corrosion.
- Ensure provided information is accurate. Issues resulting from inaccurate information are the installer's responsibility.

Example Layout

In the example given below, you can see a twelve solar module system laid out in two rows. With this layout, (14) IR-15/IR-30/IR-45/IR-35A Frames and (48) IR-F2 Solar Module Flange Clamp Bonding Brackets were used. Only a single IR-15/IR-30/IR-45/IR-35A is required for every solar module, with one extra being required to start each row. This system is capable of racking modules of any size, as the spacing of the IR-15/IR-30/IR-45/IR-35A Brackets can be adjusted to the width of the solar module. There is no limit to the number of modules that can be placed in a row, and the more modules in a row, the stronger the system will be. Approximately 6 feet between rows of IR-15/IR-30/IR-45/IR-35A Brackets is recommended to avoid shading, but actual row spacing is determined by the set height of the solar modules.

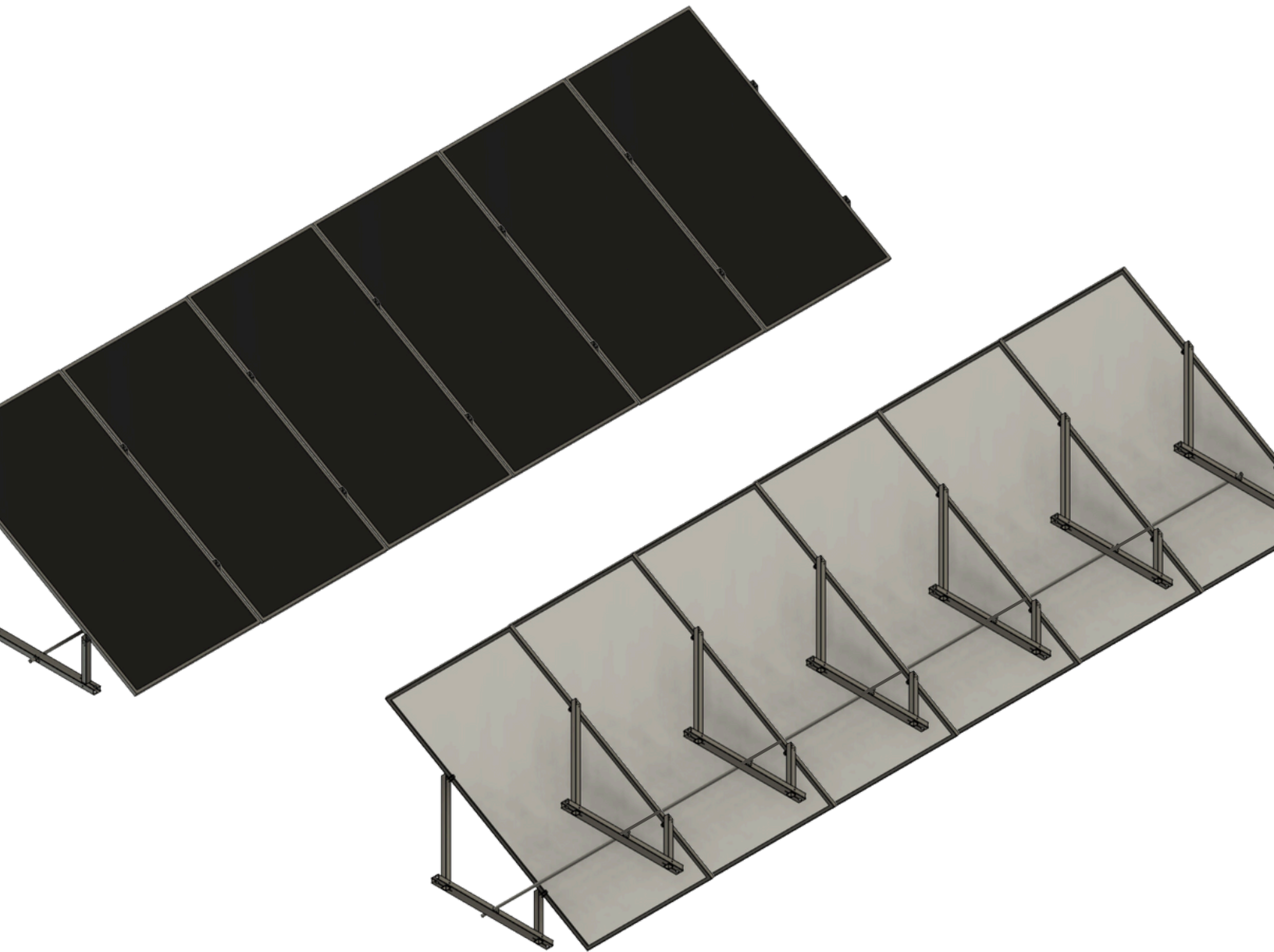

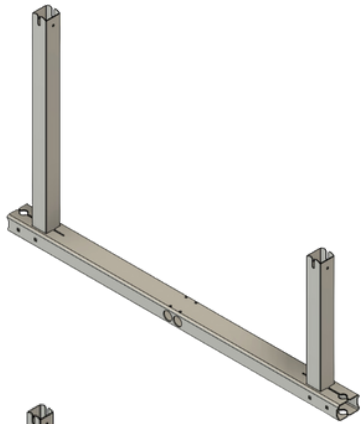

IR-15 BallastRack™ Solar Racking System

The IR-15 is designed to rack solar panels at a fixed 15° sun angle for optimal year-round energy production in equatorial regions such as Florida, Southern Texas and most tropical islands. This system also boasts up to 200mph wind load ratings.

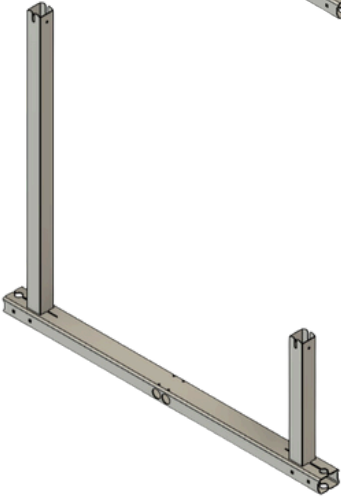

IR-30 BallastRack™ Solar Racking System

The IR-30 is designed to rack solar panels at a fixed 30° sun angle for optimal year-round energy production throughout most of the United States. This system can withstand up to 150mph wind load ratings and up to 100lbs per sq. ft. snow load ratings with a great angle for snow shedding.

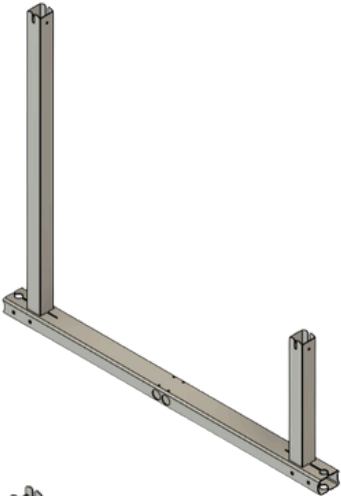

IR-45 BallastRack™ Solar Racking System

The IR-45 is designed to rack solar panels at a fixed 45° sun angle for optimal year-round energy production throughout most of the northern United States and Canada. This system can withstand up to 120mph wind load ratings and up to 100lbs per sq. ft. snow load ratings with a perfect angle for snow shedding.

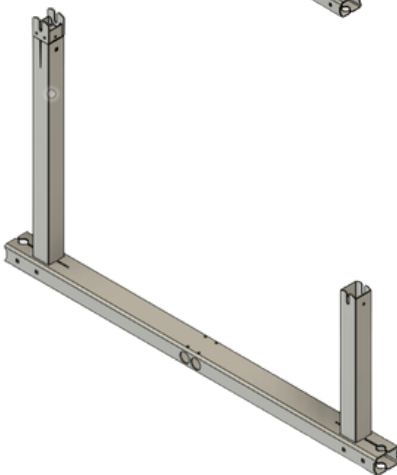

IR-35A Adjustable BallastRack™ Solar Racking System

The IR-35A offers the flexibility to choose the optimal sun angle for your situation with its adjustable leg. This system can be set anywhere from 15°-35° in 2.5° increments using a single carriage bolt for each frame. Not intended for seasonal adjustment.

See page 20 for angle adjustment

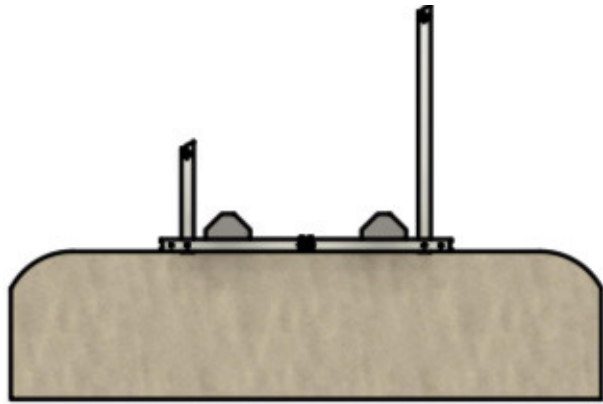

Base Ballast Mounting

Each IR-15/IR-30/IR-45/IR-35A can be mounted using water tote tanks or concrete curb stops for temporary or permanent mounting of solar modules.

Water tote tank not provided (minimum weight and dimensions listed on Page 19).

Concrete curb stops can be sourced locally minimum weight and dimensions listed on Page 19).

Stakes required

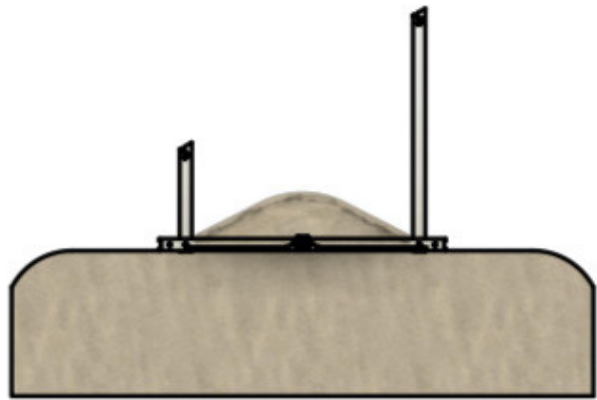

IR EarthBallast™ System

Our IR EarthBallast™ Kit comes with pre-cut rolls of strong Geotextile made for retaining walls and a high-strength tested 5 minute epoxy to hold the Geotextile to the frames. This creates a large surface area to hold the dirt mound. Each module section requires a mound of dirt, road base, or gravel that is approximately 15 inches high or 700 pounds. A shovel or skid-steer can be used to cover the frames with earth fill.

Stakes not required, but are recommended

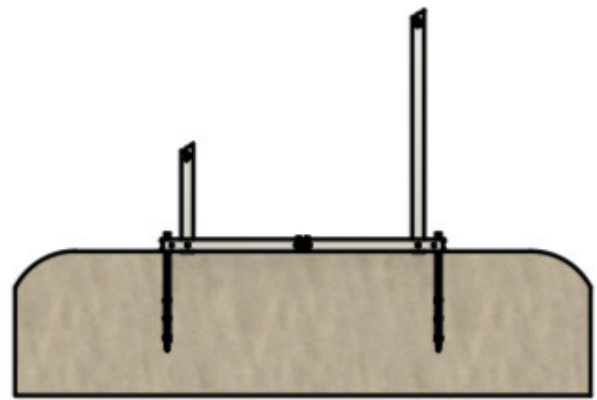

IR AnchorSpike™ System

Our IR AnchorSpike™ Kit comes with our specially designed 19.5 inch barbed aluminum spikes, which have a hollow structure to allow our super strong two-part epoxy to flow deep into the soil and create a solid anchor in the soil rated for up to 600 pounds of uplift per spike in most soil types. Each Frame has clamps at each end to clamp onto the (2) IR AnchorSpikes which allows for fast and easy leveling of the system. IR-AnchorSpikes must be tested in soil at installation site to ensure they can withstand a minimum of 400 pounds of uplift.

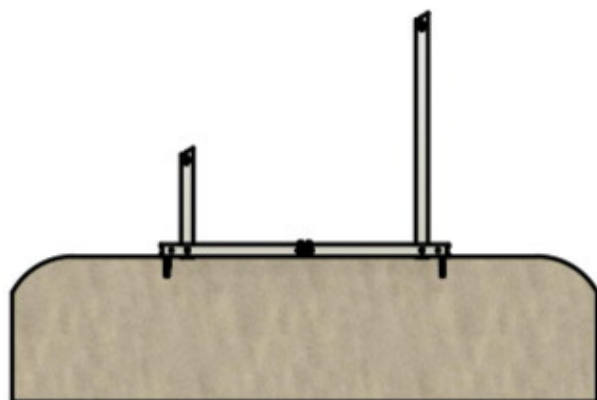

Concrete Slab/Footing Anchor Bolt Mounting

Our IR Concrete Anchor Bolt Mounting Kit provides (22) Concrete Anchor Bolts for the strongest possible mounting, and allows for easy installation of up to 10 solar modules. The Frames can be direct bolted to pre-cast concrete footings or most existing concrete surfaces, such as patios and driveways (local site specific engineering required).

IR-15 Included Components

- (1) IR-15 Base Tube
- (1) IR-15 Short Leg
- (1) IR-15 Long Leg
- (4) IR-F2 Flange Clamp Bonding Brackets
- (4) M8-1.25 x 90mm Carriage Bolts
- (4) M8-1.25 Serrated Nuts
- (4) M8-1.25 x 16mm Thread Cutting Bolts



IR-30 Included Components

- (1) IR-30 Base Tube
- (1) IR-30 Short Leg
- (1) IR-30 Long Leg
- (4) IR-F2 Flange Clamp Bonding Brackets
- (4) M8-1.25 x 90mm Carriage Bolts
- (4) M8-1.25 Serrated Nuts
- (4) M8-1.25 x 16mm Thread Cutting Bolts

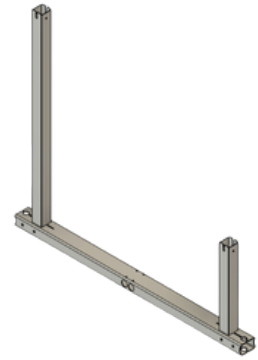

IR-45 Included Components

- (1) IR-45 Base Tube
- (1) IR-45 Short Leg
- (1) IR-45 Long Leg
- (4) IR-F2 Flange Clamp Bonding Brackets
- (4) M8-1.25 x 90mm Carriage Bolts
- (4) M8-1.25 Serrated Nuts
- (4) M8-1.25 x 16mm Thread Cutting Bolts



IR-35A Included Components

- (1) IR-35A Base Tube
- (1) IR-35A Short Leg
- (1) IR-35A Adjustable Leg
- (1) M8-1.25 x 60mm Carriage Bolt Lock
- (4) IR-F2 Flange Clamp Bonding Brackets
- (4) M8-1.25 x 90mm Carriage Bolts
- (4) M8-1.25 Serrated Nuts
- (4) M8-1.25 x 16mm Thread Cutting Bolts



IR-F2 Solar Module Flange Clamp Bonding Bracket

The IR-F2 is engineered to secure your solar modules without the necessity of rails, streamlining the process to allow a single person to install solar panels faster and easier than ever. Its innovative under-mount design prevents panels from flexing out of the clamp, a common issue with conventional over-mount clamps found in rail-based setups. This design feature enhances durability, enabling the system to withstand wind speeds of up to 200 mph.



Required Tools

Tools Needed

- Screw Gun with 1/2" Socket (**DO NOT USE AN IMPACT GUN**)
- 4' Level
- Tape Measure
- String Line

Assembly & Fastener Locations

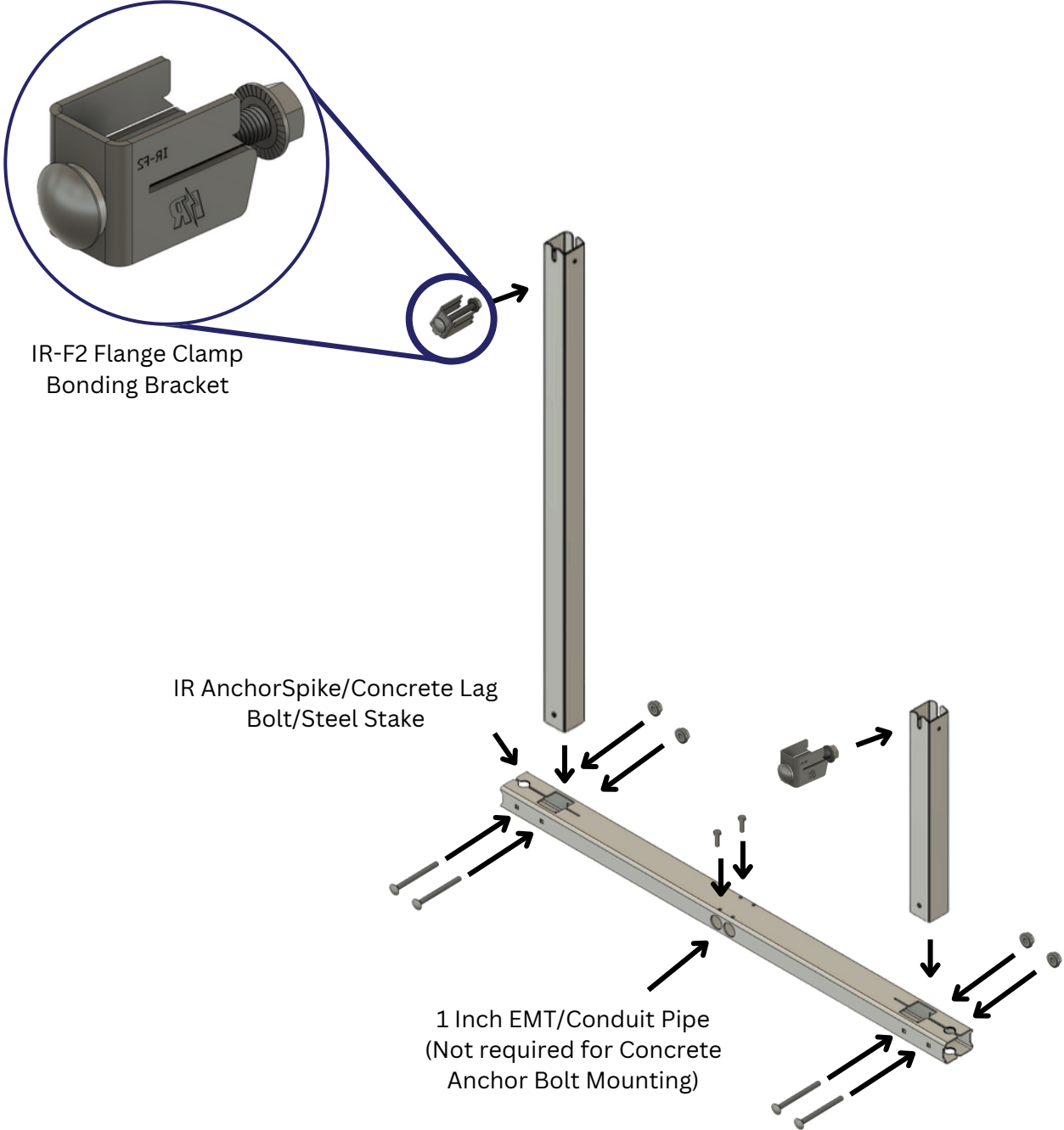

Mounting Kit Components



Geotextile Material



Quick Cure 5 Min. Epoxy



IR AnchorSpike



Concrete Anchor Bolt

IR EarthBallast Kit

- Quick Cure 5 Min. Epoxy Resin
- Extra Mixing Nozzle
- 3' x 50' Roll of Geotextile Material
- Alcohol Wipes
- Scotch-Brite Pad
- 1/2" Open-Ended Ratchet Wrench

IR AnchorSpike Kit

- (10/22) IR AnchorSpikes
- Epoxy Resin A
- Epoxy Resin B
- Mixing Cup
- 3oz Measuring Cups
- Stirring Stick
- Funnel
- Gloves
- 1/2" Open-Ended Ratchet Wrench

Concrete Anchor Bolt Kit

- 3/8" x 2.5" Titen HD Anchor Bolts
- (2) 3/8" Concrete Drill Bits
- 1/2" Open-Ended Ratchet Wrench

Additional Tools Required For Mounting Kits

IR Earth Ballast Kit

- Caulk Gun
- Shovel
- Skid-Steer Loader (Optional)

IR Earth Spike Kit

- Small Sledge Hammer
- Claw Hammer (for frame height adjustment)
- SDS Plus Hammer Drill
- 3/4" x 18" SDS Concrete Drill Bit

Concrete Slab/Footing Kit

- SDS Plus Hammer Drill
- Chalk Line

Assembling Frames

The following instructions can be used for assembly and installation of the IR-15, IR-30, IR-45 and IR-35A. Please see page 20 for angle adjustment of the IR-35A. All of these systems will simply be referred to as “Frames”.

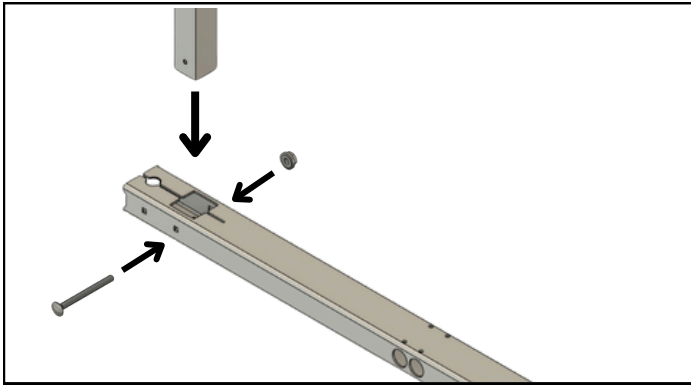

Figure 1

1. Install The Long Leg

Insert the Long Leg into the square opening at the back of the Base Tube and make sure the top is angled towards the front of the Base Tube. Line up the round holes at the bottom of the Long Leg with the corresponding hole in the side of the Base Tube and insert (1) M8-1.25 x 90mm Carriage Bolt all the way through. Tighten the Long Leg in place using (1) M8-1.25 Serrated Nut.

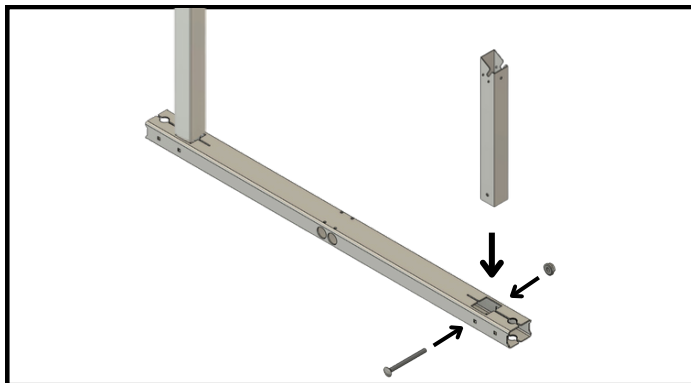

Figure 2

2. Install The Short Leg

Insert the Short Leg into the square opening at the front of the Base Tube and make sure the top is angled towards the front of the Base Tube in line with the Long Leg. Line up the round holes at the bottom of the Short Leg with the corresponding hole in the side of the Base Tube and insert (1) M8-1.25 x 90mm Carriage Bolt all the way through. Tighten the Long Leg in place using (1) M8-1.25 Serrated Nut.

Repeat Steps 1 & 2 until all Frames are assembled.

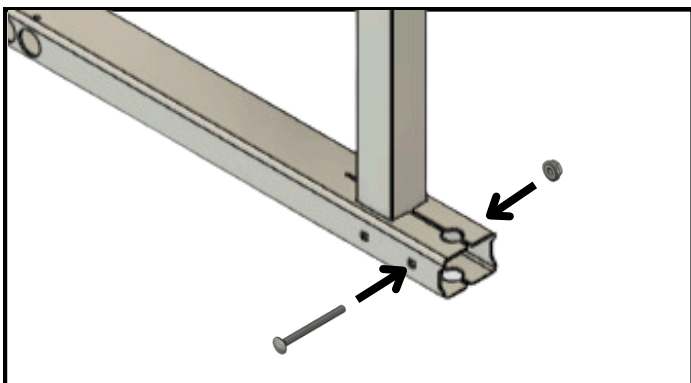

Figure 3

OPTIONAL

If you are NOT installing the IR-15/IR-30/IR-45/IR-35A with steel concrete forming stakes or IR AnchorSpikes, the remaining (2) M8-1.25 x 90mm Carriage Bolts can be used to clamp the ends of the Base Tube in this step (See Figure 3).

Steel concrete forming stakes are only required for Base Ballasted Mounting and are recommended with the IR EarthBallast Mounting Kit

Frame Spacing

Important Disclaimers

- This step is not required if you are mounting Frames with Concrete Anchor Bolts.
- Use the following formula to determine the exact spacing between Frames: **Module Width Minus 1 Inch = Space Between Base Tube Frames** (Example: 42.58 Inch Solar Module = 41.58 Inch Spacing Between Each Base Tube).
- Be sure to measure between the 2x3" lower Base Tubes and not between the 2x2" leg tubes.
- It is recommended to verify your measurements by placing a solar module in between the two frame legs to confirm spacing measurements are correct before final positioning and mounting.
- Be careful not to strip the Thread Cutting Bolts with screw gun and try to avoid the need to remove them after tightening. If frames need to be adjusted, only loosen bolts as much as needed to adjust spacing.

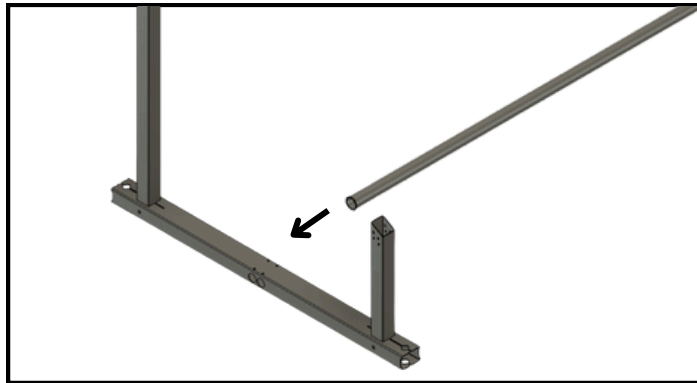

Figure 4

3. Insert 1 Inch EMT/Conduit Pipe

Once all Frames are assembled, place one at the start of the row and insert the Conduit Pipe into one of the openings in the side of the Base Tube (See Figure 4). Slide the pipe all the way through, but leave at least 2 inches hanging out on one side.

1 Inch Conduit Not required for Concrete Anchor Bolt Mounting

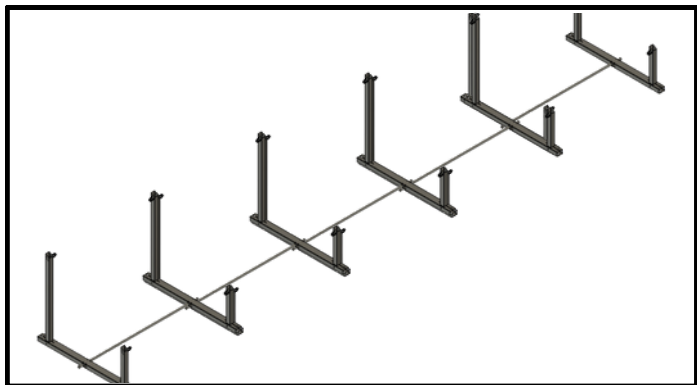

Figure 5

4. Lay Out Frames

Slide the next Frame along the conduit pipe and space them roughly where they will need to be according to your solar module's width (make sure the conduit pipe goes through the same opening on each Frame). Once the end of the first conduit pipe is reached, insert the next conduit pipe through the other opening on the last Frame (See Figure 6). Repeat this until all Frames are connect by the conduit pipes and are spaced roughly to your solar module's width.

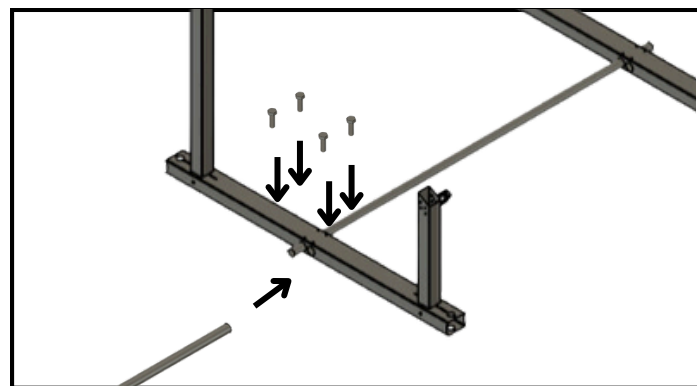

Figure 6

5. Lock Frames In Place

Once all Frames are in place, start bolting the frames directly to the conduit pipe. Use a tape measure to confirm distance between frames is correct before bolting each one to the conduit pipe. Each Frame will require (2) M8-1.25 x 16mm Thread Cutting Bolts to lock it in place on the conduit pipe. Frames connected to two conduit pipes will require all (4) M8-1.25 x 16mm Thread Cutting Bolts (See Figure 6).

No cutting or coupling of the conduit pipe is required. Repeat Steps 3-5 until all Frames are properly spaced.

Leveling Frames

Important Disclaimers

- Even when placing Frames on pre-leveled ground, there can still be some irregularities in the frame system. Before leveling the system, it is important to make sure that all Frames are lined up in a straight line using a string line.
- After lining up the Frames, stakes can be hammered in place at the front and back of each Frame. Stakes are optional, but recommended to keep system in line and for assisting with leveling the frames.

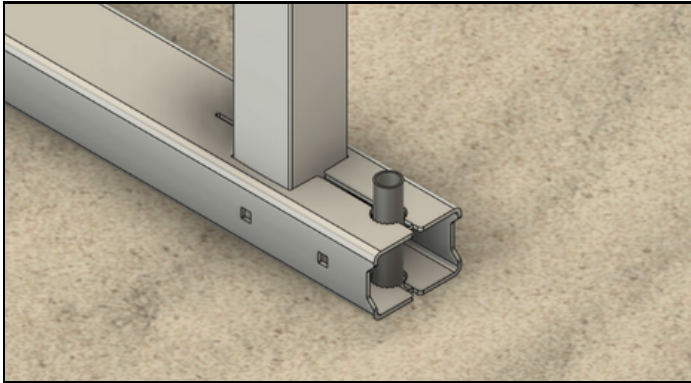

Figure 7

OPTIONAL

Stakes can be used for fast and easy leveling. Use a small mallet to hammer concrete stakes into the ground through the stake openings at the end of each base tube. Each base tube can now be leveled using a level/stringline and clamped to the stakes by tightening the bolts at the end of each Base Tube.

See Step 1 on page 16 for more detailed instructions on this procedure.

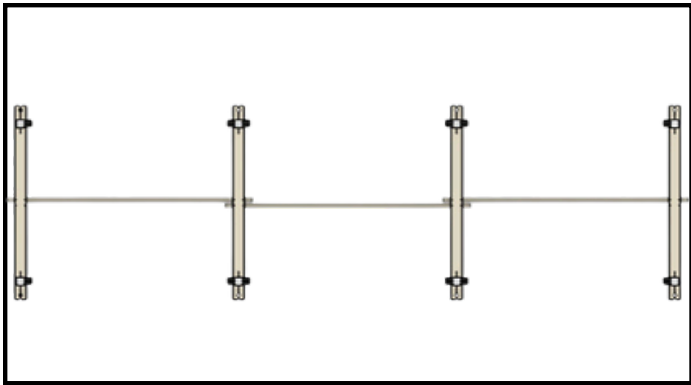

Figure 8

1.Line Up The Frames

Run a string line from the Long Leg of the first Frame, stretch it along the frame system to the Long Leg of the last Frame. Adjust the system as necessary until all Frames are aligned with the stringline.

OPTIONAL: Stakes can be used to keep system in line during alignment and assist with leveling of the frames.

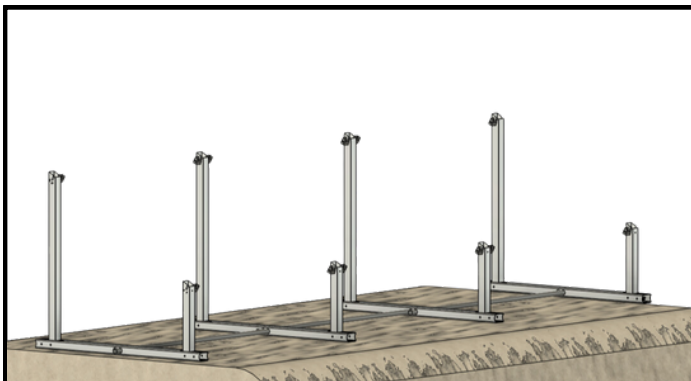

Figure 9

2.Leveling The Frames

The easiest way to level the system is to run a string line along the tops of the Base Tubes and bring them all up to the string line. Using a shovel, dirt can then be added or removed from under the Frames to level the system.

Attaching Geotextile

Important Disclaimers

- It is important to use the provided Scotch-Brite scuff pads and alcohol wipes to prep the application surface of each IR-15/IR-30/IR-45/IR-35A before epoxy is applied.
- Keep in mind that the epoxy will set up in 5 minutes, so be sure to roll the geotextile along the way as the epoxy is applied.

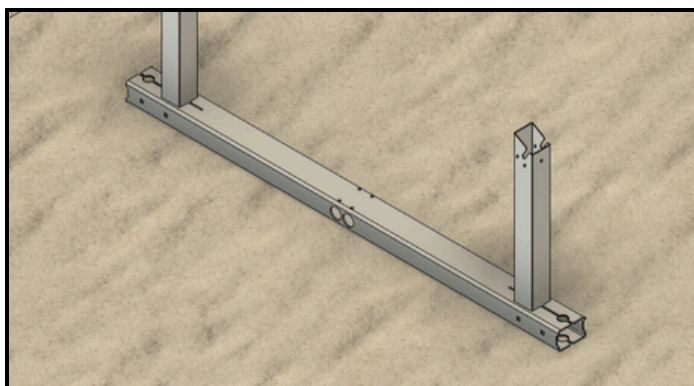

Figure 10

3. Prep Adhesive Surface

Use the included Scotch-Brite Scuff Pad to scuff the top of each Base Tube to remove the surface layer of oxidization and to promote better adhesion. Just before applying the epoxy, clean the surface using the provided alcohol wipes.

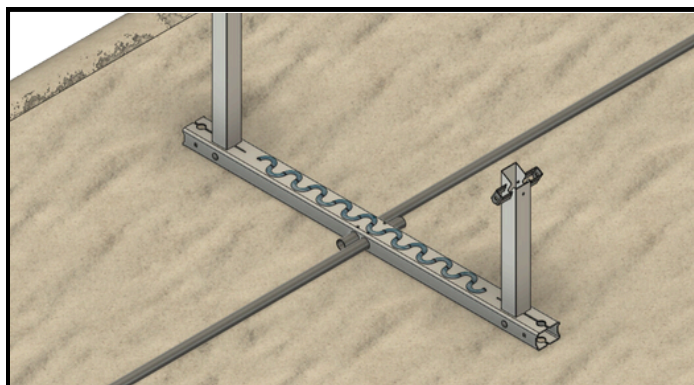

Figure 11

4. Apply Adhesive

Remove the twist cap and pull the sealing plug from the Quick Cure-5 Epoxy and attach the mixing nozzle. Using a caulk gun, apply the epoxy in a zig zag pattern along the top of each IR-15/IR-30/IR-45/IR-35A Base Tube in between the two upright legs (See Figure 11).

It is important to note that epoxy only requires 5 minutes to set up, so larger installations may require rolling the Geotextile Material after every 3 or 4 frames have had the epoxy applied to them.

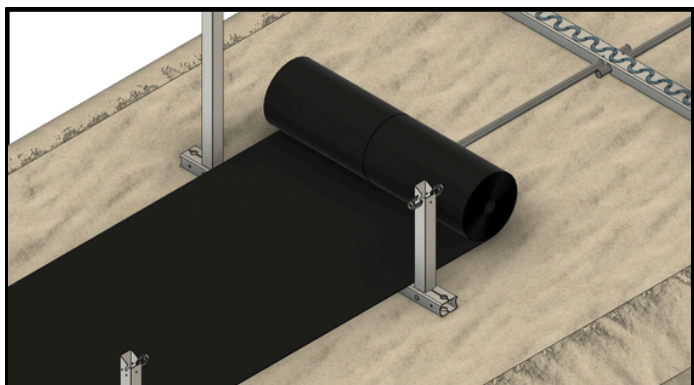

Figure 12

5. Roll Out The Geotextile Material

Secure the first foot of the geotextile roll with weights or rocks ahead of the first frame and pull lightly while unrolling it across the top of the wet epoxy. Keep light tension between each frame section before pulling the material down onto each frame. Before epoxy sets up, use rubber gloves to lightly rub the geotextile material into the wet epoxy before the 5 minutes has lapsed.

Earth Filling Frames

Important Disclaimers

- It is recommended to determine the weight of the soil being used for ballasting, to determine how much is needed. Each module will require at least 700 pounds of soil (approximately a 15 inch high earth mound).
- It is best to use compactable soil for ballast system as loose soil or sand may be displaced by high winds.
- Earth mound should be uniform in shape and size across the entire system to ensure even ballasting.
- Ensure highest point of the earth mound is slightly closer to the Long Legs for better weight distribution.



Figure 13

6. Earth Fill Frames

Using a shovel or a skid-steer, dump a pile of material onto the Geotextile in between each Frame. The highest point of the earth mound should be approximately 15 inches high or 700 pounds per solar module section. *Repeat this step until every frame is covered.*



Figure 14

7. Pack The Earth Mound

Use a shovel to pack the earth mound down and form it with a shovel/rack into a uniform shape. Make sure the center of the mound is closer to Long Legs for better weight distribution.



Figure 15

Proceed To Page 21 For Module Installation

Drilling Holes For IR AnchorSpikes

Important Disclaimers

- Ensure that soil is compacted otherwise IR AnchorSpikes will not be as effective.
- It is recommended to test (1) IR AnchorSpike in the soil at installation site to ensure at least 400 pounds of uplift.
- Make sure to drill holes as straight as possible.

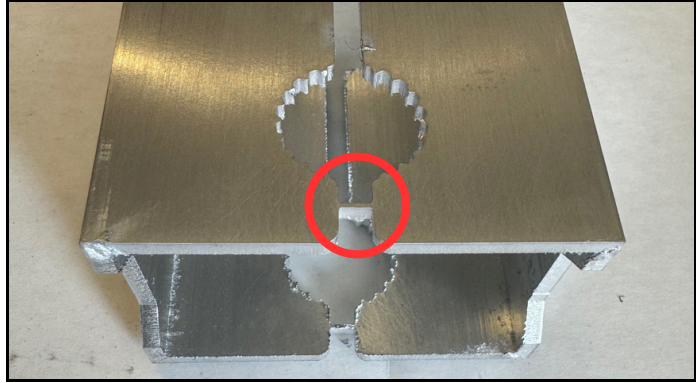

Figure 16

1. Remove Part Separator Strip

If your Base Tube parts have this little part separator strip, use a small hand grinder with a metal cut-off wheel to remove it so your AnchorSpikes or 3/4" steel stakes can be clamped fully without interference.

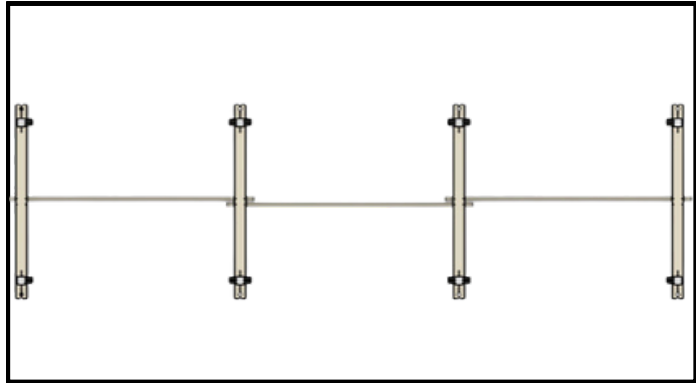

Figure 17

2. Line Up The Frames

Run a string line from the Long Leg of the first Frame, stretch it along the frame system to the Long Leg of the last Frame. Adjust the system as necessary until all Frames are aligned with the stringline.

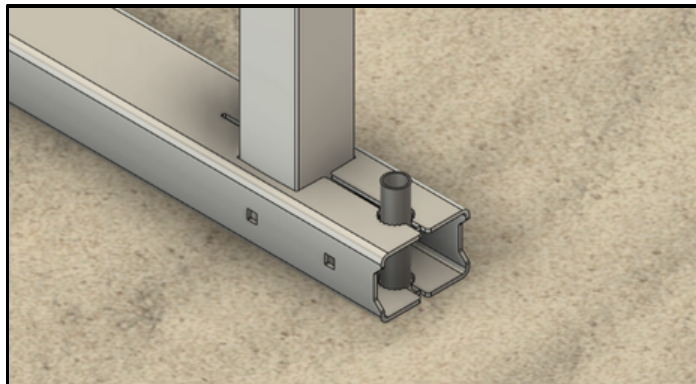

Figure 18

3. Mark Drilling Locations

Hammer a concrete stake or one of the AnchorSpikes 1-2 inches into the ground through the open holes at each end of the Base Tube to mark the ground for the AnchorSpike pre-drilling locations.

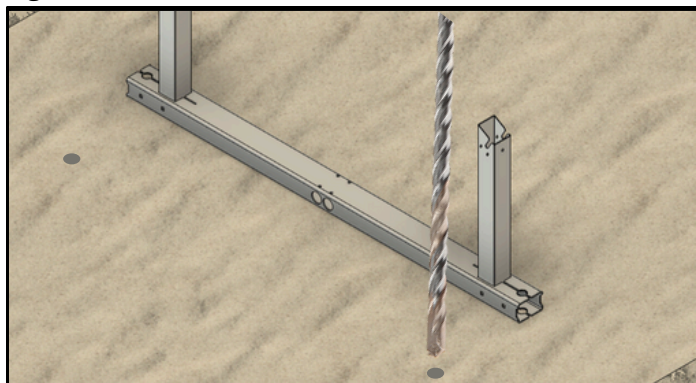

Figure 19

4. Drill Holes For IR AnchorSpikes

Move the entire system 2-3 inches left or right so the holes can be drilled with the frames out of the way for drilling. Using an SDS Hammer Drill and a 3/4" x 18" SDS Concrete Drill Bit to drill a 16 inch deep hole at each of the marked locations. Then move the system back into place and line up the frame hole openings with the pre-drilled holes.

Installing IR AnchorSpikes

Important Disclaimers

- Make sure to thoroughly mix the two part epoxy for the recommended time to ensure proper wind load capabilities.
- Epoxy takes approximately 8 hours to set up.
- Wear the provided rubber gloves to avoid getting epoxy on skin.



Figure 20

5.Placing IR AnchorSpikes

Using a small sledge hammer, tap the IR Anchor Spikes into the pre-drilled holes through the clamp ends of each Frame and leave approximately 2 inches above the Base Tube. This extra 2 inches will allow for leveling of the Frames.



Figure 21

6.Mixing The Epoxy

Pour the A and B Epoxy components into the provided mixing container and stir for 2-3 minutes with the included stirring stick.

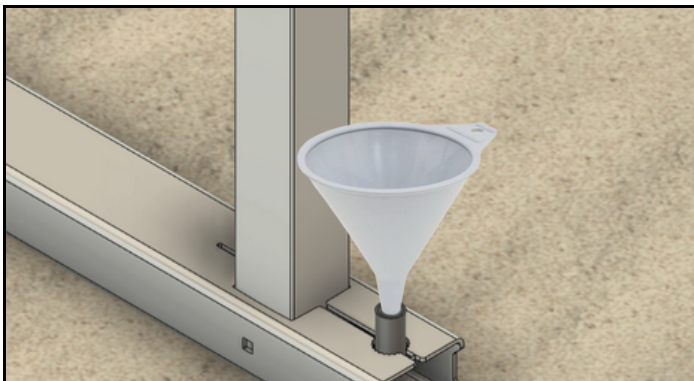

Figure 22

7.Pour The Epoxy Into The IR AnchorSpikes

Now pour the epoxy into one of the small 3oz cups to 1/4" down from the top of the cup and use the included funnel to pour this measured amount through the top of each IR Anchor Spike. Allow 8-10 hours for the epoxy to set up.

Leveling Frames

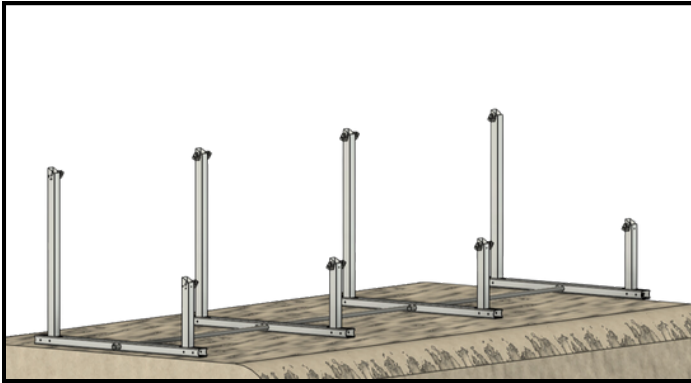

Figure 23

8. Leveling Frames

The easiest way to level the system is to run a string line along the tops of the Base Tubes and bring them all up to the string line. Level each frame one at a time and clamp the base tubes to the AnchorSpikes to keep them level. Once level, proceed to the next step.

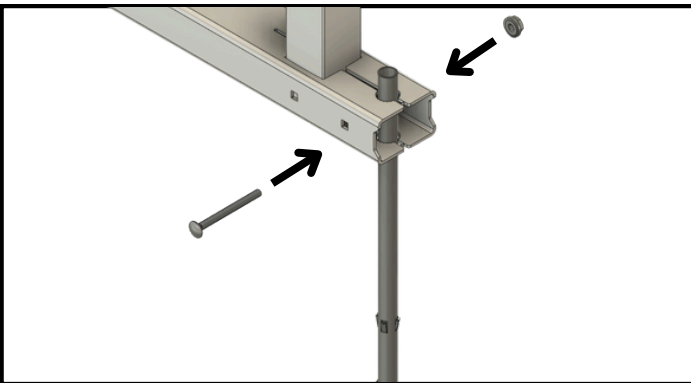

Figure 24

9. Clamp AnchorSpikes

Use the remaining 3.5 Inch carriage bolts to clamp the ends and lock the Base Tube in a level position by clamping it onto the AnchorSpike (See Figure 24).



Figure 25

Proceed To Page 21 For Module Installation

Measuring & Installation

Important Disclaimers

- Make sure that all Frames are straight in line before mounting to ensure proper module mounting.

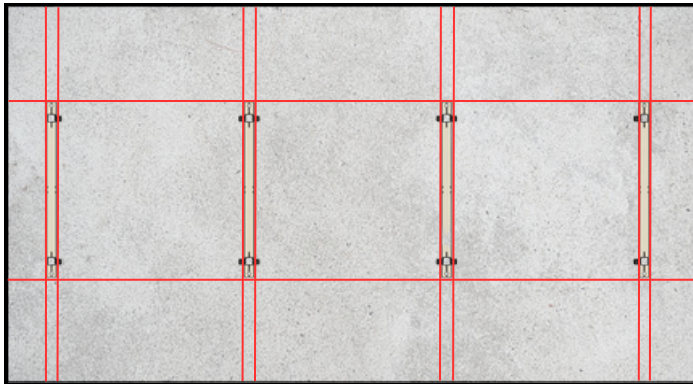

Figure 26

1. Measure & Chalkline Frame Placement

Use the formula provided on page 11 to calculate the distance needed between Frames. Place all Frames at the exact spacing and mark both sides of each Base Tube. Make sure the Frames at each end of the row are lined up straight and mark from the first frame to the last frame and chalk a line in between (See Figure 26).

Double check spacing between Frames

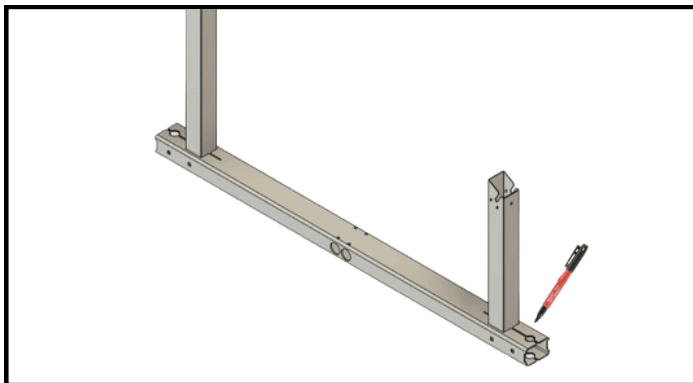

Figure 27

2. Mark The Drilling Locations

Move each Frame into their marked positions and use a permanent marker to outline the opening at the end of each Base Tube where the Concrete Anchor Bolts will go into the concrete.

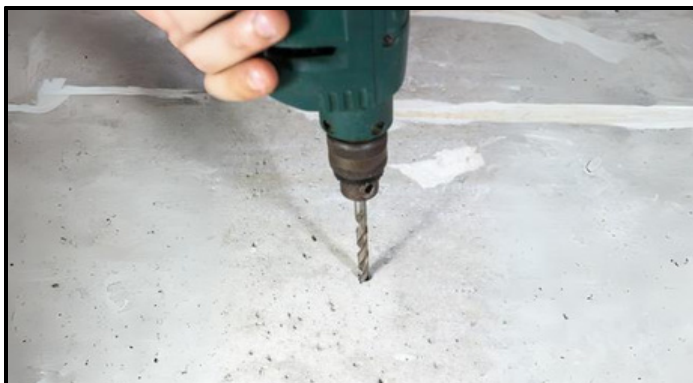

Figure 28

3. Drill Holes

Move all Frames out of the way and use an SDS Hammer Drill and the included 3/8" Concrete Drill Bit to drill a 3 inch deep hole in the middle each of the marked locations on the concrete.

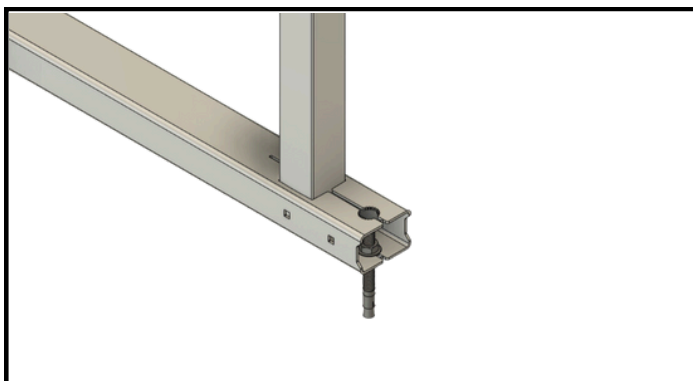

Figure 29

4. Bolt The Frames To The Concrete

Move all Frames back into their marked locations, and bolt them in place using the provided IR Concrete Anchor Bolts and washers.

Placing Ballast

Important Disclaimers

- Steel stakes are recommended for this mounting option to prevent movement of system.
- For Water Tank Ballast, treated lumber or another weather resistant material may be needed as a platform to hold the water tank above the bolt heads on the base tube.

Flat Water Tank Ballast



Figure 30

Recommended Water Tank

For water tank ballasting, we recommend using RecPro's 100 gallon tank or a similar water tank with the dimensions outlines below. This water tank can be placed across up to (3) Frames.

Water Tank Dimensions

- Minimum Length: Width of Solar Panel + 6 Inches
- Maximum Width: 34 Inches
- Maximum Height: 12 Inches

Placing Water Tank

Place water tank inside of the "U" shaped frames and up against the Long Legs to properly distribute the weight for uplift.

Concrete Curb Stop Ballast



Figure 31

Concrete Curb Stop Weight

- Minimum Weight: 350 Pounds Per Module

Placing Concrete Curb Stop

Place concrete curb stop across at least (2) of the IR-15/IR-30/IR-45/IR-35A Base Tubes. Multiple curb stops can be used per module as long as the minimum weight is met.

IR-35A - Adjusting The Sun Angle

Important Disclaimers

- This system is NOT intended for seasonal angle adjustment.
- Always ensure that the adjustable leg is locked firmly in place to maintain maximum wind and snow ratings.
- The numbers on the front and back of the adjustable legs marks the set sun angle.
- Make sure that all frames are set to the same angle for each row.

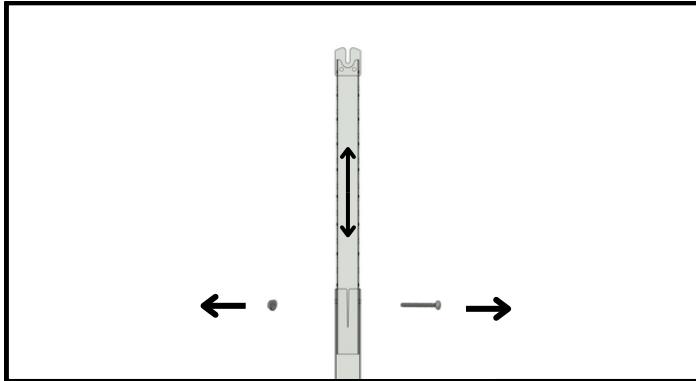

Figure 32

1. Remove The Locking Bolt

The adjustable leg of each IR-35A should be set at 30° when you receive it. To change the angle, simply remove the locking bolt from the side of the leg by loosening the serrated nut with a 1/2 inch wrench. Be careful not to lose the washer inside (Some frames do not have washers).

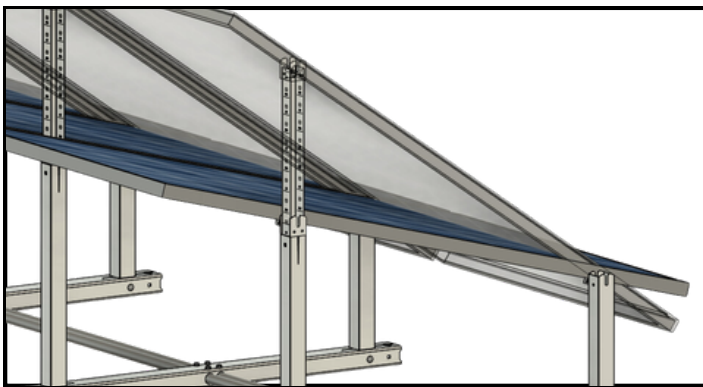

Figure 33

2. Set The Sun Angle

Slide the adjustable leg to the desired sun angle by using the numbers in the front and back of each leg. Each number represents the angle of the system when the line below that number is lined up with the base of the leg.

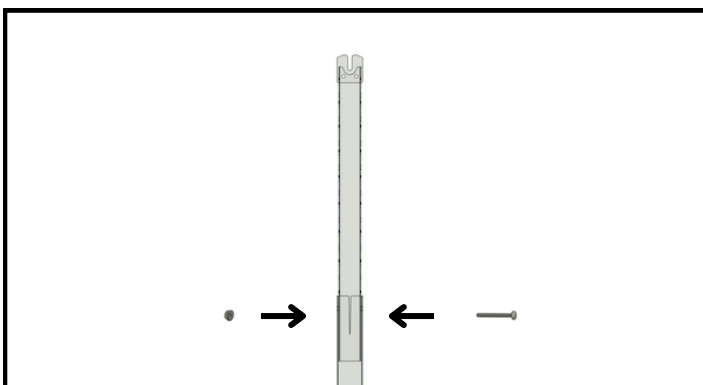

Figure 34

3. Lock The Sun Angle

Once at the desired angle, insert the locking bolt through the base and adjustable leg and tighten the serrated nut. Make sure that the adjustable leg is firmly locked in place to maintain maximum wind and snow ratings (If your frame has a washer, do not forget to put the washer back during assembly).

Installing Solar Modules

Important Disclaimers

- Solar module height can be adjusted after mounting by sliding them along the flange clamps before tightening serrated nuts.
- Have IR-F2 Flange Clamp Bonding Brackets readily available before placing modules for fast mounting.
- The flange of the module will fit into the slot cut into the side of the IR-F2 and the pointed barbs should be inside the flange for bonding of the modules.
- Make sure to remove the serrated nut before placing the IR-F2 clamp onto the flange of the solar panel. Once the clamp is on the flange, the serrated nut can be put back in place.

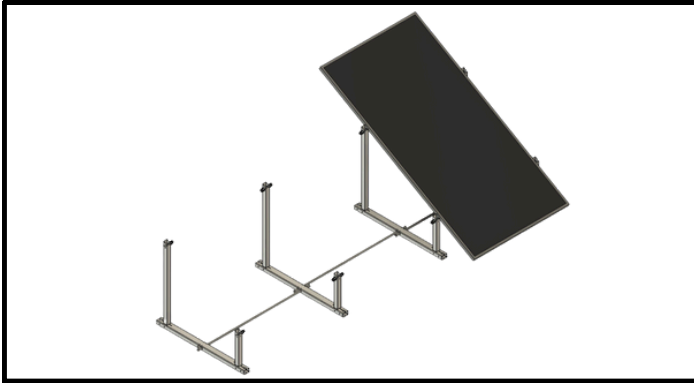

Figure 35

1. Position The First Solar Module

Carry solar module and place it into position between the the first two Frames. Set the module roughly where it will be mounted.

2. Mount Upper IR-F2 Brackets

Lift the top of the solar module above the Long Legs of the Frames and get ready to place the IR-F2 Clamp on one side of the module. Each solar module is to be attached to the legs by four IR-F2 Clamps. Make sure to remove the serrated nut on the end of each IR-F2 before attaching it onto the flange of the solar module. Slide the IR-F2 onto the flange and thread the serrated nut back on to the end of the bolt (only two turns of the serrated nut is necessary for now). Once the first IR-F2 Clamp is attached to the solar module, slide it along the flange until the bolt is over the open slot at the top of the Long Leg and drop it in. Tighten the nut by hand for now and repeat this process on the other side.



Figure 36

3. Mount Lower IR-F2 Brackets

Repeat Step 2 with the lower IR-F2 clamps and leave the serrated nuts tightened by hand for now.

4. Adjust Solar Module Height

Once all solar modules are in place, they can be slid up and down to ensure that they are all the same height for a clean looking system. The serrated nuts may need to be loosened before doing so. Simply slide the modules to the desired position and use the ratchet wrench included with your base mounting kit to tighten all of the serrated nuts and lock the modules in place. If you did not purchase a mounting kit most 1/2" or 13mm wrench will work provided they are small enough to fit in between the bolts.



Figure 37



More IR-15,30,45,35A Info

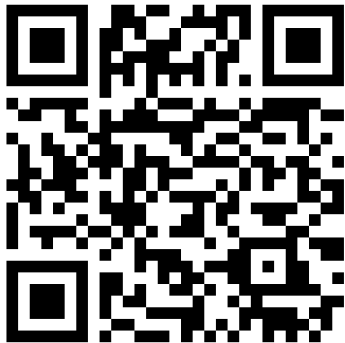

**See Our Other
Revolutionary Products**



©IntegraRack 2024, All Rights Reserved. Multiple US Patents Pending

www.IntegraRack.com