

Rail King[®]

MOBILE RAILCAR MOVER



RAIL KING[®] MODEL RK330

The Rail King Model RK330 Mobile Railcar Mover provides up to 49,250 pounds of tractive effort. Improvements that increase operator safety and productivity include:

- ▶ Enclosed insulated cab with 360-degree visibility. Ergonomically designed with touch hydraulic controls. Standard equipment includes windshield wipers front and rear, cab heater, two defrost fans and full instrumentation including tachometer and tinted safety glass. Dual operator stations are standard.
- ▶ Patented cushion coupler system, full-floating frame and cab design that provides a smooth ride on rail.
- ▶ Wider and taller cab-entry doors, more floor space, more leg room and insulated engine cowling for operator comfort.
- ▶ Hydraulically driven train air compressor for reliable service.
- ▶ Cab deck includes walkover platform, stair-step ladder and solid bar stock hand railing. Large rubber isolators support the cab.
- ▶ Full light package (coupler, railwheel, stop, red and white interior, headlights, step lights and flashing beacon).
- ▶ Hydraulic control system consolidated and located for ease of servicing and maintenance.

Contact your local Rail King representative to find out how we can increase productivity for your switching operations.

RK330

DESIGN FEATURES

- ▶ Friction roadwheel drive
- ▶ Four-speed transmission, autoshift or powershift selection
- ▶ Crossover platform
- ▶ 360° operator visibility
- ▶ Full width bumpers to protect powertrain
- ▶ Good floor space and cab height for ease of moving around
- ▶ Fabricated steel couplers
- ▶ Extended couplers-standard equipment

OPTIONS

- ▶ Air conditioning
- ▶ Air ride seats
- ▶ Step extensions
- ▶ Spotlights
- ▶ Turn signals
- ▶ Fire extinguisher
- ▶ 75-gallon fuel tank
- ▶ Central lube system
- ▶ Remote control
- ▶ Other options available on request



BUILDING FOR THE NEXT CENTURY



STEWART & STEVENSON RK330

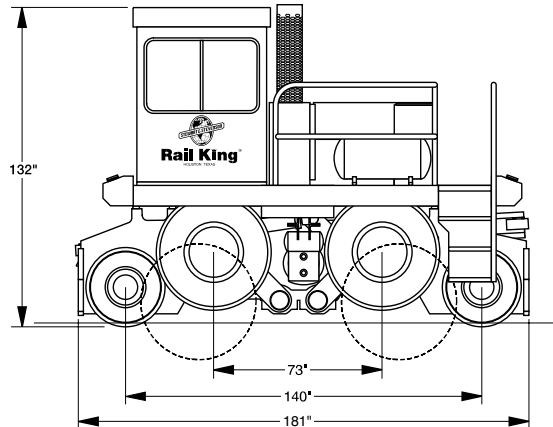
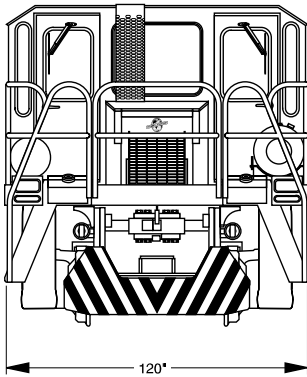

SPECIFICATIONS

GENERAL

WEIGHT	51,500 lb
LENGTH	181"
WIDTH	120"
HEIGHT (ON ROAD)	142"
HEIGHT (ON RAIL)	132"
RAIL CLEARANCE	3"
ROAD CLEARANCE	10"
SPEEDS (FORWARD & REVERSE)	4
ON ROAD	9 mi/h
ON RAIL	15 mi/h

ENGINE

MAKE	Cummins
MODEL	QSB 6.7
TYPE	4-cycle, turbocharged diesel
RATED POWER	204 bhp @ 1900 rpm
FUEL TANK	40 gal
FEATURES	Tier III compliant

MAXIMUM TRACTIVE EFFORT

WHEN BOTH COUPLERS ARE USED	49,250 lb
WHEN ONE COUPLER IS USED	33,000 lb

FRAME

Heavy-duty, welded from 2" steel plate

MUFFLER

Sound-attenuating, spark-arresting with rain cap

TRANSMISSION

John Deere DF150 with torque converter, four speeds forward and reverse, autoshift or power-shift selection

RAIL- & ROAD-DRIVE

John Deere spiral bevel gear set; designed for bi-directional operation, no spin differential with internal planetary axles. Friction drive transmitted from rail-drive axle incorporates separate braking system. Does not require special tires. Rail shock absorption system standard.

BRAKES

Inboard multiple wet-disk brakes. Protected from contaminants and can last up to four times longer than dry-disk brakes. Spark-free for regulatory compliance in hazardous environments.

RAILWHEELS

28" diameter heat-treated cast steel. Tapered tread contour to AAR specifications.

ROADWHEELS

Hard rock lug 16-ply 12.00 x 20

PNEUMATIC SYSTEM

High capacity 50-cfm air compressor system. Includes two compressors, three reservoirs with drains, air dryers, lever operated pressure control valve with emergency stop capability.

POWER STEERING

Full hydrostatic power steering.

COUPLERS

Two weight-transfer couplers made from fabricated steel (no castings). Couplers slide on high-density self-lubricating nylon bearings for long life and minimal maintenance. This heavy-duty coupler system operates on a center pivot housed in a massive synthetic rubber cushion pressed into both sides of the frame.

SANDERS

Replaceable steel sandboxes and eight air-operated sanding tubes with easy clean receivers: two for each rail wheel, front and back.

FULL-WIDTH CAB

Provides excellent visibility down both sides of the railcar when negotiating curves. Standard equipment includes dual controls, two seats, front and rear wipers, heater, two defrost fans and tempered safety glass, foot and hand throttle and brake actuators.

CONTROLS

Improved console with electric switches to implement functions at each operating position. Instrument panel positioned for viewing ease of operator.

OTHER FEATURES

Air blast horn and protect-o-seal fuel cap.

CONTACT US TODAY

Stewart & Stevenson

8787 East Freeway

Houston, TX 77029

Telephone: (713) 679-6525

Facsimile: (713) 671-6386

email: railking@ssss.com

www.stewartandstevenson.com

Rail King[®]
MOBILE RAILCAR MOVER



SSLLC2006-05-018 ©2006 STEWART & STEVENSON

The information in this bulletin is believed to be accurate but all recommendations are made without warranty, since the conditions of use are beyond Stewart & Stevenson's control. Stewart & Stevenson disclaims any liability in connection with the use of this information, and does not warrant against infringement by reason of the use of any of its products in combination with other material or in any process. Stewart & Stevenson warrants only that the product complies with specifications agreed to in contracts of sale.