

AirFlow HVLS Fans

BLUE GIANT®



EAGLE VI - 12' TO 24' DIAMETER HVLS FANS
HIGH VOLUME LOW SPEED TECHNOLOGY

Eagle VI HVLS Fans

STANDARD FEATURES

- A Custom-Engineered Airfoils**
Contoured for maximum air movement, so environments become cooler faster.
- B Wingtips**
Decreases vortices that are harmful to the efficiency of the fan.
- C Environmentally Durable Chassis**
Resists rusting and corrosion even in cold and damp environments.
- D Extension Bar**
Different sizes available to suit site layout and requirements.
- E Optional: Touchscreen Controller †**
Uses intelligent touch technology to control two or more HVLS fans.

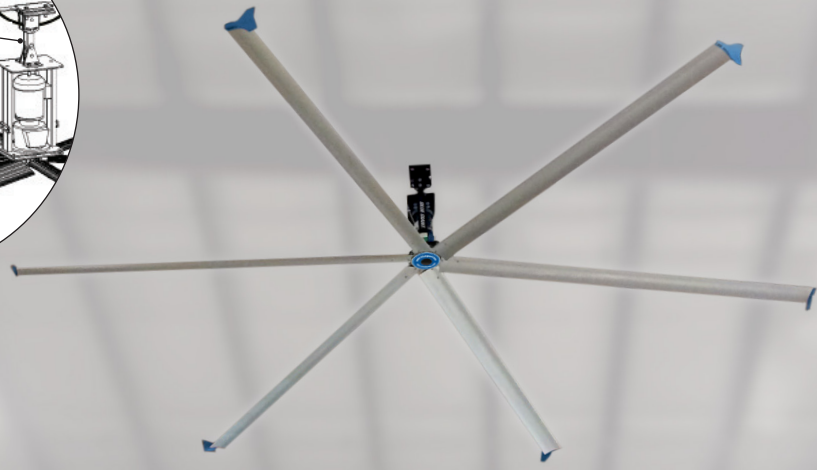
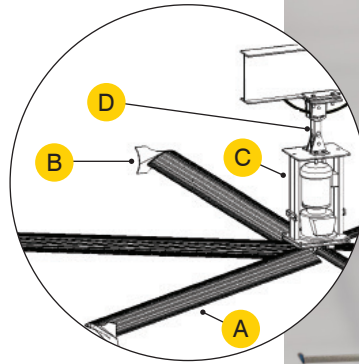

Single phase available. 115V or 230V with both 50Hz. and 60Hz.
Three phase available. 230V, 460V or 575V with both 50Hz. and 60Hz.
† Not Illustrated in photo.

Seasonal Benefits: Create comfortable conditions year round.

Six-Blade Comfort Solution

- Available blade sizes of 12' to 24' (3.6 m to 7.3 m)
- Innovative and aerospace-inspired blade design moves more air with less energy
- Six-airfoil system increases air velocity in summer and de-stratifies hot air pockets in winter
- Produces a higher distribution of airflow than other styles of airfoils
- Compliments existing HVAC systems
- Reduces condensation, corrosion and mold
- Quiet operation

Low on Cost, High on Performance

- Costs pennies an hour to operate
- Energy cost reduction of up to 30%
- Lowers perceived temperatures by up to 15°F
- Reduces air conditioning usage
- Increases employee comfort and productivity in medium to large locations
- Compatible with Blue Giant AutoPilot multi-fan controller for added functionality

Applications

- Warehouses
- Manufacturing facilities
- Sports stadiums
- Indoor arenas
- Auto dealerships
- Agriculture
- Retail facilities



EAGLE VI

Sample Application:

	EXISTING 2-BLADE PROP FANS	PROPOSED 16' HVLS FANS
Quantity	30	8
CFM Each	16,368	166,856
CFM Total	491,040	1,334,848
CFM / Watt	21.6	238.37
Total Watt	22,733	5,600

BLUE GIANT
BLUE GIANT EQUIPMENT CORPORATION

Corporate 410 Admiral Blvd
Mississauga, ON, Canada L5T 2N6
t 905.457.3900 f 905.457.2313

USA 6350 Burnt Poplar Road
Greensboro, NC 27409
www.bluegiant.com

AUTHORIZED DEALER

Blue Giant offers a full line of dock levelers, dock safety equipment, seals and shelters, accessories, ergonomic and scissor lift equipment and industrial trucks. Concurrent with our continuing product improvement program, specifications are subject to change without notice. Please contact Blue Giant for latest information. Some features illustrated may be optional in certain market areas.