



Cleavenger

Compliance Training & Consulting, Inc.

Your Hometown Safety Experts



Volume 4, Issue 7

JULY 2018
419-843-8936



Since 1995

THE CLEAVENGER COMPLIANCE CONNECTION

President's Corner



**HAPPY Independence Day
to all our friends!**

We are happy to announce that Cleavenger Compliance Training & Consulting, Inc. has joined in a partnership with the Professional Remodelers Organization (PRO)! We will be working closely with PRO to help their members receive top-notch safety training, facility auditing, written programs, investigation services and everything the PRO members need to keep their employees safe and to satisfy their on-going training requirements.

"There are hundreds of local companies that belong to PRO and being able to touch these companies and their employees with regards to safety is a challenge we are excited to be a part of"

PRO offers many rewards for being a member, listed below just a few of them.
Member benefits include;



- Continuing Education Classes. (Discount to members)
- Members referring members and PRO referrals to home owners looking for services.
- Networking Opportunities: 7 network nights per year, Golf Outings, Christmas Parties and other gatherings.
- Business to business networking.
- Advertising Opportunities: Web-site, Home Show, Television and Radio.
- PRO- Member Discount: PRO discount card to local businesses and much more...

We will also be conducting open enrollment training at the PRO facility located in Sylvania, Ohio. Make sure to watch the newsletter for training opportunities for your employees.

For questions about a PRO membership, contact Clare Greenfield at 419-471-0101 or email her at Clare@hireaprotoday.com

In This Issue:

- Pro Builders Association
- Open Enrollment Classes
- Fireworks Safety
- AED Myth vs Facts
- OSHA Rule Proposal

Welcome New Clients!

TransCanada Pipelines

Thompson Station, Tennessee

Inteva Products

Adrian, Michigan

R&I Construction

Tiffin, Ohio

CONTACT US

419-843-8936

General E-mail

ConnectionInfo@CleavengerCompliance.com

Bryan Cleavenger

President

Bryan@CleavengerCompliance.com

Tony Hartung

Operations Manager

TonyH@CleavengerCompliance.com

Barb Libstorff

CPR/FA Program Manager

Barb@CleavengerCompliance.com

Erik Cleavenger

Sales Manager

ErikC@CleavengerCompliance.com

Ashley Purcell

Office Manager

AshleyP@CleavengerCompliance.com

Check Out Our Websites



Open Enrollment Part 46 / 8-Hour Refresher/New Miner Mine Safety Training

*When: July 17, 2018

*Where: 420 Madison Ave. Toledo, Ohio 43604

*Cost: \$265.00 per person (Parking, Lunch & Snacks Included)

Call today to reserve your spot! 419-843-8936



Fireworks Safety

According to the NFPA, Each July 4th, thousands of people, most often children and teens, are injured while using consumer fireworks. Despite the dangers of fireworks, few people understand the associated risks, devastating burns, other injuries, fires and even death.

Here are a few statistics and safety tips to consider before you "light the wick" on your 4th of July fun...

- Fireworks start an average of 18,500 fires per year, including 1300 structure fires and 300 vehicle fires.
- These fires cause an average of 3 deaths, 40 injuries and an average of \$43 million in property damage.
- In 2015, U.S Hospital Emergency rooms treated nearly 12,000 people for firework related injuries.

Safety Tips...

- Keep a watchful eye on the kids
- ALWAYS follow the safety instructions
- Obey local laws
- Never carry fireworks in your pocket
- Do NOT shoot fireworks into a container
- NEVER relight a "dud" firework
- Spent fireworks should be wetted down after use
- Dispose of fireworks in a metal trash bin
- Do Not experiment with homemade fireworks
- Only use fireworks outside
- Only use fireworks in clear areas
- Protect your eyes

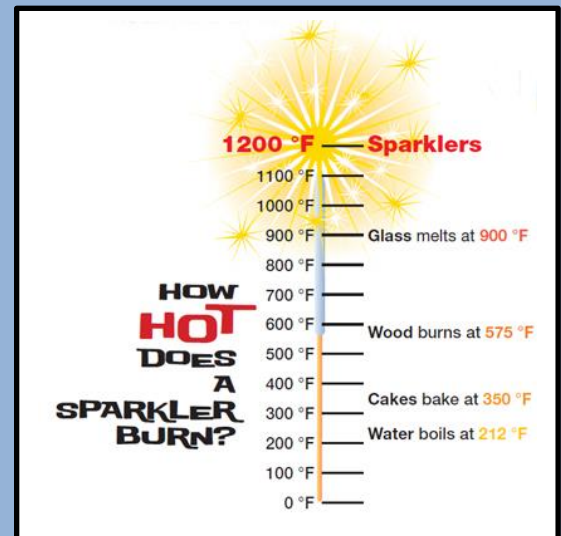

July Safety Tip of the Month... Bench Grinders

- 1/8" gap maximum between the work rest and grinding wheel
- 1/4" gap maximum between the tongue guard and wheel
- A ring test should be conducted prior to using a new wheel
- Pedestal style grinders must be affixed to the floor
- All manufacturer guards must be in place before use

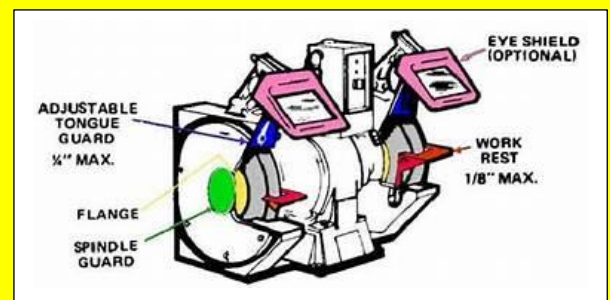



As Safety Professionals, we often receive many questions regarding the use of AED units. These are good questions, but we hope this article will help clarify some of the “myths” of AED use. As always, don’t hesitate to contact us if you have any questions.

Myth: You can shock someone with an AED as a joke or by mistake.

Fact: An AED will only shock someone when electrode pads are placed correctly on a patient in cardiac arrest and one of two specific rhythms are detected. You cannot accidentally or intentionally shock a conscious, healthy person with a public access device AED.

Myth: Just like on TV, if someone goes into cardiac arrest, you can bring them back to life with CPR alone.

Fact: If someone is revived with CPR alone, chances are they were not actually in cardiac arrest, but instead they were suffering some other heart-related condition. The ONLY treatment for sudden cardiac arrest is defibrillation either with an AED or a defibrillator used in hospitals and by emergency medical professionals.

Myth: Only medical professionals can use an AED because you need special training to do it right.

Fact: Anyone who can read the visual directions and/or hear the verbal prompts can use an AED correctly and save a life!

Myth: Only old people go into sudden cardiac arrest.

Fact: Anyone, anywhere at any time can go into sudden cardiac arrest. It does not discriminate based on age, gender, ethnicity or fitness. Athletes, children, all races and both genders are equally at risk. In fact, 16 people under the age of 18 die every day from sudden cardiac arrest, and every 72 hours a young athlete’s life is ended by SCA.

Myth: A heart attack and sudden cardiac arrest are the same thing.

Fact: A heart attack is a plumbing problem caused by a blockage of the arteries in the heart, leading to the death of part of a heart’s muscle mass. Sudden cardiac arrest is an electrical problem caused by the heart’s inability to beat correctly and pump blood to the brain and vital organs, causing the patient to become unconscious immediately due to oxygen deprivation.

Myth: If you use an AED and the person dies anyway you can be sued for causing their death.

Fact: Good Samaritan laws exist in all states to provide protection for rescuers who act in good faith to help another person who is in a life-threatening situation such as sudden cardiac arrest.

Did You Know....

Approximately 41% of all firework injuries are to the head? And, children younger than 15 years of age account for 26% of injuries reported each year...





The U.S. Department of Labor's Occupational Safety and Health Administration today announced a proposed rule to increase the safety of America's construction sites. In addition to providing long-term clarity regarding crane operator certification requirements, the proposal reinstates the employer duty to ensure that a crane operator is qualified to safely operate equipment.

Under the proposed rule, a change to the categories of certifications for crane operators would ensure more operators are able to meet the requirement. The proposal discontinues a 2010 requirement, which never went into effect, that crane operator certification must include the crane lifting capacity for which the operator is certified. The proposal would expand the type of certification programs for crane operators.

OSHA recently published a final rule extending the operator certification compliance date until November 10, 2018, in order to provide the agency with additional time to complete this rulemaking to address stakeholder concerns related to the Cranes and Derricks in Construction standard.

Cleavenger Compliance Training & Consulting, Inc. provides Training, Written Programs, Incident, Accident, Injury and Near-Miss Investigation services and can also help you in the event of an OSHA or MSHA Investigation.

Give us a call for more information regarding these services at 419-843-8936.

Safety Fails!

