

General Catalogue





The SKF® brand now stands for more than ever before, and means more to you as a valued customer.

While SKF maintains its leadership as the hallmark of quality bearings throughout the world, new dimensions in technical advances, product support and services have evolved SKF into a truly solutions-oriented supplier, creating greater value for customers.

These solutions encompass ways to bring greater productivity to customers, not only with breakthrough application-specific products, but also through leading-edge design simulation tools and consultancy services, plant asset efficiency maintenance programmes, and the industry's most advanced supply management techniques.

The SKF brand still stands for the very best in rolling bearings, but it now stands for much more.

SKF – the knowledge engineering company

General

Foreword.....	5
SKF – the knowledge engineering company	10
Contents.....	14

Quantity	Unit	Conversion			
Length	inch	1 mm	0,03937 in	1 in	25,40 mm
	foot	1 m	3,281 ft	1 ft	0,3048 m
	yard	1 m	1,094 yd	1 yd	0,9144 m
	mile	1 km	0,6214 mile	1 mile	1,609 km
Area	square inch	1 mm ²	0,00155 sq.in	1 sq.in	645,16 mm ²
	square foot	1 m ²	10,76 sq.ft	1 sq.ft	0,0929 m ²
Volume	cubic inch	1 cm ³	0,061 cub.in	1 cub.in	16,387 cm ³
	cubic foot	1 m ³	35 cub.ft	1 cub.ft	0,02832 m ³
	imperial gallon	1 l	0,22 gallon	1 gallon	4,5461 l
	U.S. gallon	1 l	0,2642 U.S. gallon	1 U.S. gallon	3,7854 l
Velocity, speed	foot per second	1 m/s	3,28 ft/s	1 ft/s	0,30480 m/s
	mile per hour	1 km/h	0,6214 mile/h (mph)	1 mile/h (mph)	1,609 km/h
Mass	ounce	1 g	0,03527 oz	1 oz	28,350 g
	pound	1 kg	2,205 lb	1 lb	0,45359 kg
	short ton	1 tonne	1,1023 short ton	1 short ton	0,90719 tonne
	long ton	1 tonne	0,9842 long ton	1 long ton	1,0161 tonne
Density	pound per cubic inch	1 g/cm ³	0,0361 lb/cub.in	1 lb/cub.in	27,680 g/cm ³
Force	pound-force	1 N	0,225 lbf	1 lbf	4,4482 N
Pressure, stress	pounds per square inch	1 MPa	145 psi	1 psi	6,8948 × 10 ³ Pa
Moment	inch pound-force	1 Nm	8,85 in.lbf	1 in.lbf	0,113 Nm
Power	foot-pound per second	1 W	0,7376 ft lbf/s	1 ft lbf/s	1,3558 W
	horsepower	1 kW	1,36 HP	1 HP	0,736 kW
Temperature	degree	Celcius	$t_C = 0,555 (t_F - 32)$	Fahrenheit	$t_F = 1,8 t_C + 32$

Foreword

The previous multilingual edition of the SKF General Catalogue was originally published in 1989. Since that time it has been translated into 16 languages and over 1 million copies have been distributed worldwide. In that edition SKF introduced the “New Life Theory”, which since has become a major new technical standard for the bearing industry. With this broad usage and professional acceptance, the SKF General Catalogue is generally considered to be the authoritative reference source of its type throughout industry.

The General Catalogue was subsequently converted to electronic formats for added accessibility and convenience – available in a CD-ROM version, titled “SKF Interactive Engineering Catalogue”, and online at www.skf.com.

This new edition of the General Catalogue is also available electronically as well as in print and includes many revisions, additions and enhancements to make the catalogue even more useful and valuable. A familiarization with the information in this foreword, as well as other annotated sections, enables the user to obtain the maximum benefit from this comprehensive tool.

This foreword discusses the main sections of the catalogue with reference to major technical and product information as well as other available information of importance in understanding the overall capabilities of SKF.

General Catalogue overview

This new SKF General Catalogue contains almost all of the standard rolling bearings and accessories required by industrial equipment manufacturers, as well as those used for replacement purposes. To provide the highest levels of service, SKF endeavours to have its standard assortment match virtually all customer needs and to have products available on a worldwide basis.

The data in this catalogue relate to SKF's state-of-the-art technology and production capabilities as of mid 2005. The data may differ from that shown in earlier catalogues because of redesign, technological developments, or revised methods of calculation.

SKF reserves the right to make continuing improvements to SKF products with respect to materials, design and manufacturing methods, as well as changes necessitated by technological developments.

The units used in this catalogue are in accordance with ISO (International Organization for Standardization) standard 1000:1992, and SI (Système International d'Unités).

Technical section – principles of bearing selection and application

The technical section covers the basics of bearing technology as required for the design of a bearing arrangement. The sections are arranged in the order normally followed by a design engineer.

Significant innovations in the technical section

- A new model for the determination of frictional moment in rolling bearings.
- Revised speed ratings for the thermally permissible reference speeds based on the new friction model.
- A new model for the determination of the requisite lubricant viscosity, based on more accurate knowledge of the influence of raceway surface roughness and of the elastic deformation of the lubricant film.
- A new method to determine lubricant service life as well as the optimum relubrication intervals for grease-lubricated bearings.
- The progress made in rolling bearing technology and the experience accumulated in practical applications in recent years have been taken into consideration and are referenced where appropriate in the various sections of the technical part.
- SKF technical services related to the bearing, the machine, or even the complete manufacturing plant – from bearing selection and calculation, to installation, monitoring, maintenance and replacement, are covered in a separate section.

Product section – bearing designations, descriptions and data

The product tables contain the engineering data required for the selection of a bearing and its application. Information relating to the specific types of bearings covered is arranged in front of the relevant product table(s).

Notable innovations in the product section

Significant products included for the first time are, in order of appearance

- ICOS™ bearing/seal units
- stainless steel deep groove ball bearings
- sealed spherical roller bearings
- CARB® toroidal roller bearings
- hybrid deep groove ball bearings
- INSOCOAT® bearings
- high-temperature ball bearings and Y-bearing units
- NoWear® bearings
- Solid Oil bearings.

Investigations have shown that factors such as mounting, lubrication and maintenance have a much greater influence on bearing life than previously assumed. For this reason, new information has been included on

- SKF products for maintenance and lubrication
- SKF condition monitoring equipment and systems.

Several SKF innovations are worthy of particular note as they offer many advantages for enhanced performance or greater productivity.

For example, some of SKF product enhancements make it possible to build smaller machines having the same or even better performance. Smaller size also implies lighter weight; meaning less friction, lower operating temperatures, reduced lubricant requirements and power consumption, and as a result, improved economy and added value.

To facilitate easy reference to the various product innovations among the volume of information contained in this catalogue, the specific products are identified as follows

- SKF Explorer bearings – the new performance class from SKF
- application optimized bearings – standard bearings tailored for specialized requirements
- mechatronic components – combinations of bearings and electronic sensors.

These innovations represent the most important new products in this catalogue and will be explained in more detail under their appropriate headings in the product section. For convenience, a summary description of these products is included hereafter.

SKF Explorer bearings – the new performance class from SKF

SKF Explorer is a new performance class of rolling bearings, of the types angular contact ball bearings, cylindrical roller bearings, spherical roller bearings, CARB toroidal roller bearings and spherical roller thrust bearings, which provide a substantial improvement in key operational parameters relevant to the bearing type and its typical applications. This new level of superior performance represents the blending

of SKF's applications knowledge with its expertise in tribology, materials development, design optimization and manufacturing.

Using advanced analytical and modelling techniques and supporting testing, SKF engineers were able to confirm that SKF Explorer bearings provide a significant improvement in key operational parameters. These parameters, according to bearing type and application, include noise, vibration, service life, dimensional stability, dynamic load carrying ability and heat generation (frictional moment). Because these parameters are not adequately factored into standardized life calculations, SKF Explorer bearing life is calculated with modified factors, which takes key operational parameters into account.

SKF Explorer bearings are fully interchangeable with previously specified SKF standard bearings of the same type and size. These bearings are included in the relevant product tables and are easily identified by an asterisk (*) in front of the bearing designation.

The making of an SKF Explorer bearing

Achieving the outstanding levels of SKF Explorer bearings has only been possible due to the basic sound engineering design of SKF products and by further improving the manufacturing of bearings to these designs. By studying the interrelationship between each bearing component, SKF engineers were able to maximize the effects of lubrication and minimize the effects of friction, wear and contamination. To do this, an international research team looked at each component at micro level and then developed new procedures to consistently manufacture this new standard of excellence.

SKF Explorer bearings are characterized by a number of technical improvements, some of which are listed below. Depending on the type of the SKF Explorer bearing one or several of these below given examples have been applied:

- Improved bearing steel
SKF Explorer bearings feature an extremely clean and homogenous steel with a minimum number of inclusions. This improved steel is so much cleaner than the highest grades covered by present classification methods that SKF has developed new calculation methods to take this factor into account.

- The unique SKF heat treatment procedures
To maximize the benefits of SKF's ultra-clean steel, engineers incorporated unique heat treatment procedures. These new procedures optimize the bearing's resistance to operational damage without affecting heat stabilization. Wear resistance was improved so dramatically that SKF engineers were not able to accurately predict life expectancy using existing life factors for calculation methods.
- Improved surface finish
The surface finish on all contact surfaces (rolling elements and raceways) has been improved to maximize the effects of the lubricant and reduce vibration and noise levels. This has led to a smoother, cooler running bearing that uses less lubricant and consequently the arrangement, including the seals, requires less maintenance.

Deep groove ball bearings and taper roller bearings

For the rolling bearing types deep groove ball bearings and taper roller bearings there have been many performance improvements since the last SKF General Catalogue. In line with the SKF product strategy, improvements for deep groove ball bearings and taper roller bearings have sufficiently been implemented for certain sizes to qualify as SKF Explorer class bearings. For these selected deep groove ball bearing sizes improved sealing, precision and surface finish, give reduced noise and vibration levels and improved running accuracy. Similarly for selected taper roller bearing sizes, improved surfaces for better lubrication and significantly reduced noise and vibration levels, cleaner steel in combination with improved heat treatment give significantly longer life. Because all these parameters are not adequately factored into standardized life calculations, the bearing life of selected sizes SKF deep groove ball bearings and taper roller bearings is calculated with modified factors in line with all SKF Explorer class bearings.

Application optimized bearings – tailored bearings

These bearings have standardized dimensions but incorporate special features for specific applications. Properly applied, these bearings make costly customized bearings unnecessary, and they can also greatly reduce lead times since they are generally available from stock. This group of SKF bearings includes the following:

- Hybrid deep groove ball bearings with ceramic balls and rings of bearing steel. These bearings have good emergency running properties and can cope with extreme conditions and high speeds. Their inherent resistance to the passage of electric current means that they are very suitable for electric motors and electrically powered tools.
- INSOCOAT bearings have an insulating coating of aluminium oxide on the external surfaces of the inner or outer ring. These bearings can be used in difficult electrical applications with no additional design requirements and they can also be a drop-in replacement for conventional bearings in existing applications.
- Bearings and bearing units for extreme temperatures. Their operating temperature range covers -150 to $+350$ °C, making these products very suitable for kiln trucks, roller hearth furnaces, bakery plants and refrigeration rooms.
- NoWear bearings. These bearings have been surface treated to withstand arduous operating conditions such as zero or very light loads or boundary lubrication conditions.
- Solid Oil bearings for applications where conventional grease or oil lubrication methods are not adequate or practical.

Mechatronic components – bearings and sensors in combination

SKF “plug and play” mechatronic bearing units can be used to monitor or control operating sequences, motion or steering systems. Information in this catalogue provides a brief overview of the mechatronic components and developments engineered by SKF, which have already been well proven in a variety of industrial and automotive applications. More in-depth information on SKF mechatronics products and

capabilities can be obtained through your SKF representative.

Detailed information on Sensor-Bearing Units, which are part of the SKF standard line, can be found together with the appropriate product data.

Other SKF products

In this section, all rolling bearings, plain bearings, linear bearings, and seals etc., not listed in the product section of the catalogue are listed with a brief description. Where further information is available, reference is made to appropriate SKF printed and/or electronic media.

SKF system solutions

SKF has applied its extensive knowledge of particular industrial applications and their demanding requirements, and developed system solutions that yield cost-effective results.

Some of these solutions do not even incorporate bearings. This underscores SKF’s continuing efforts to expand its offerings beyond traditional bearing applications to other technologies from the fields of mechatronics and electronics. Some of the more important system solutions currently available are

- Copperhead system solution for vibrating screens
- system solution for continuous casting plants
- system solution for paper machines
- system solution for printing machines
- system solution for automotive transmissions
- system solution for railway vehicles
- system solution for wind power plants.

Other SKF catalogues

Even though this General Catalogue contains more than 1 100 pages of core products and related information, it is by no means all-inclusive of the total SKF product offering. Detailed information on many of the other SKF products not covered in this General Catalogue is also available in separate, individual printed catalogues which include

- needle roller bearings
- high-precision bearings
- Y-bearings and Y-bearing units

- spherical plain bearings and rod ends
- bearing accessories
- bearing housings
- seals.

A brief description of these products can be found in this General Catalogue under the heading “Other SKF products”, starting on **page 1081**, or online at www.skf.com.

Information on the comprehensive assortment of SKF linear bearing products, ball and roller screws, and linear actuators can be found in the separate SKF catalogue “Linear Motion Product Range”, available from your SKF Linear Motion representative.

The SKF Interactive Engineering Catalogue

SKF provides this catalogue in electronic formats available on CD-ROM or online at www.skf.com. The SKF Interactive Engineering Catalogue contains comprehensive technical information on

- SKF rolling bearings inclusive accessories
- SKF bearing units
- SKF bearing housings
- SKF plain bearings
- SKF seals.

The electronic catalogue formats enable easy navigation and also provide calculations for critical design factors, such as

- basic and modified rating lives (L_{10} and L_{nm})
- requisite lubricant viscosity
- equivalent bearing load
- minimum bearing load
- dynamic axial load carrying capacity of cylindrical roller bearings
- frictional moment
- bearing frequencies
- grease life of sealed bearings
- axial displacement in CARB bearings
- shaft tolerance and resultant fits
- housing tolerance and resultant fits.

In addition, 2 or 3-dimensional drawings can be supplied in some 50 CAD formats via the SKF internet site.

SKF – the supplier of choice

The SKF General Catalogue – as comprehensive as it is – is just one of the many advantages provided to our customers. There are many other capabilities that contribute to the overall value customers receive in making SKF their supplier of choice, such as

- simplified bearing selection
- short delivery times
- worldwide availability
- commitment to product innovation
- state-of-the-art application solutions
- extensive engineering and technology knowledge in virtually every industry.

SKF – the knowledge engineering company

From the company that invented the self-aligning ball bearing 100 years ago, SKF has evolved into a knowledge engineering company that is able to draw on five platforms to create unique solutions for its customers. These platforms include bearings, bearing units and seals, of course, but extend to other areas including: lubricants and lubrication systems, critical for long bearing life in many applications; mechatronics that combine mechanical and electronics knowledge into systems for more effective linear motion and sensorized solutions; and a full range of services, from design and logistics support to conditioning monitoring and reliability systems.

Though the scope has broadened, SKF continues to maintain the world's leadership in the design, manufacture and marketing of rolling bearings, as well as complementary products such as radial seals. SKF also holds an increasingly important position in the market for linear motion products, high-precision aerospace bearings, machine tool spindles and plant maintenance services.

The SKF Group has global ISO 14001 environmental certification. Individual divisions have been approved for quality certification in accordance with either ISO 9000 or QS 9000.

With some 100 manufacturing sites worldwide and sales companies in 70 countries, SKF is a truly international corporation. In addition, our distributors and dealers in some 15 000 locations around the world, an e-business marketplace and a global distribution system put SKF close to customers for the supply of both products and services. In essence, SKF solutions are available wherever and whenever customers need them. Overall, the SKF brand and the corporation are stronger than ever. As the knowledge engineering company, we stand ready to serve you with world-class product competencies, intellectual resources, and the vision to help you succeed.

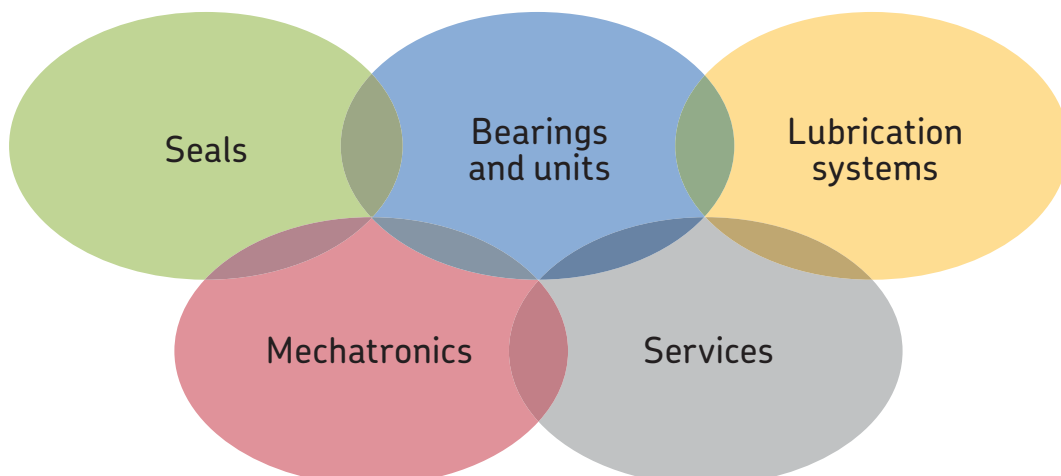



© Airbus – photo: e*m company, H. Goussé

Evolving by-wire technology

SKF has a unique expertise in fast-growing by-wire technology, from fly-by-wire, to drive-by-wire, to work-by-wire. SKF pioneered practical fly-by-wire technology and is a close working partner with all aerospace industry leaders. As an example, virtually all aircraft of the Airbus design use SKF by-wire systems for cockpit flight control.



SKF is also a leader in automotive by-wire technology, and has partnered with automotive engineers to develop two concept cars, which employ SKF mechatronics for steering and braking. Further by-wire development has led SKF to produce an all-electric forklift truck, which uses mechatronics rather than hydraulics for all controls.



Harnessing wind power

The growing industry of wind-generated electric power provides a source of clean, green electricity. SKF is working closely with global industry leaders to develop efficient and trouble-free turbines, providing a wide range of large, highly specialized bearings and condition monitoring systems to extend equipment life of wind farms located in even the most remote and inhospitable environments.



Working in extreme environments

In frigid winters, especially in northern countries, extreme sub-zero temperatures can cause bearings in railway axleboxes to seize due to lubrication starvation. SKF created a new family of synthetic lubricants formulated to retain their lubrication viscosity even at these extreme temperatures. SKF knowledge enables manufacturers and end user customers to overcome the performance issues resulting from extreme temperatures, whether hot or cold. For example, SKF products are at work in diverse environments such as baking ovens and instant freezing in food processing plants



Developing a cleaner cleaner

The electric motor and its bearings are the heart of many household appliances. SKF works closely with appliance manufacturers to improve their products' performance, cut costs, reduce weight, and reduce energy consumption. A recent example of this cooperation is a new generation of vacuum cleaners with substantially more suction. SKF knowledge in the area of small bearing technology is also applied to manufacturers of power tools and office equipment.



Maintaining a 350 km/h R&D lab

In addition to SKF's renowned research and development facilities in Europe and the United States, Formula One car racing provides a unique environment for SKF to push the limits of bearing technology. For over 50 years, SKF products, engineering and knowledge have helped make Scuderia Ferrari a formidable force in F1 racing. (The average racing Ferrari utilizes more than 150 SKF components.) Lessons learned here are applied to the products we provide to automakers and the aftermarket worldwide.



Delivering Asset Efficiency Optimization

Through SKF Reliability Systems, SKF provides a comprehensive range of asset efficiency products and services, from condition monitoring hardware and software to maintenance strategies, engineering assistance and machine reliability programmes. To optimize efficiency and boost productivity, some industrial facilities opt for an Integrated Maintenance Solution, in which SKF delivers all services under one fixed-fee, performance-based contract.



Planning for sustainable growth

By their very nature, bearings make a positive contribution to the natural environment, enabling machinery to operate more efficiently, consume less power, and require less lubrication. By raising the performance bar for our own products, SKF is enabling a new generation of high-efficiency products and equipment. With an eye to the future and the world we will leave to our children, the SKF Group policy on environment, health and safety, as well as the manufacturing techniques, are planned and implemented to help protect and preserve the earth's limited natural resources. We remain committed to sustainable, environmentally responsible growth.

Contents

Principles of bearing selection and application	
Bearing terminology	20
Bearing types.....	23
Selection of bearing type	33
Available space	35
Loads.....	37
Misalignment.....	40
Precision	40
Speed.....	42
Quiet running.....	42
Stiffness	42
Axial displacement	43
Mounting and dismounting	44
Integral seals	45
Matrix: Bearing types – design and characteristics	46
Selection of bearing size	49
System approach and reliability	50
Load ratings and life	51
Selecting bearing size using the life equations	52
Dynamic bearing loads.....	73
Selecting bearing size using the static load carrying capacity	76
Calculation examples	78
SKF calculation tools	82
SKF Engineering Consultancy Services.....	84
SKF life testing.....	85
Friction.....	87
Estimation of the frictional moment	88
More accurate calculation of the frictional moment.....	88
The new SKF model for calculation of the frictional moment.....	89
Frictional behaviour of hybrid bearings.....	102
Starting torque	103
Power loss and bearing temperature	103
Calculation example	104
Speeds and vibration.....	107
Reference speeds	108
Limiting speeds	114
Special cases	114
Vibration generation in a bearing.....	115
Influence of the bearing on the vibration behaviour of the application	115
Bearing data – general.....	117
Dimensions.....	118

Tolerances.....	120
Bearing internal clearance.....	137
Materials for rolling bearings.....	138
Cages.....	144
Designations.....	147
Application of bearings.....	159
Bearing arrangements.....	160
Radial location of bearings.....	164
Axial location of bearings.....	199
Design of associated components.....	204
Bearing preload.....	206
Sealing arrangement.....	218
Lubrication.....	229
Grease lubrication.....	231
Lubricating greases.....	231
SKF greases.....	236
Relubrication.....	237
Relubrication procedures.....	242
Oil lubrication.....	248
Mounting and dismantling.....	257
General information.....	258
Mounting.....	261
Dismounting.....	268
Storage.....	273
Inspection and cleaning.....	273
Reliability and services.....	275
An integrated platform.....	276
The Asset Efficiency Optimization concept.....	276
SKF technology and service solutions.....	277
Condition monitoring products.....	280
Product data	
Deep groove ball bearings.....	287
Angular contact ball bearings.....	405
Self-aligning ball bearings.....	469
Cylindrical roller bearings.....	503
Taper roller bearings.....	601
Spherical roller bearings.....	695
CARB toroidal roller bearings.....	779
Thrust ball bearings.....	837
Cylindrical roller thrust bearings.....	863
Spherical roller thrust bearings.....	877
Engineering products.....	893
Mechatronics.....	955
Bearing accessories.....	973
Bearing housings.....	1031
Maintenance and lubrication products.....	1069
Other SKF products.....	1081
Product index.....	1121

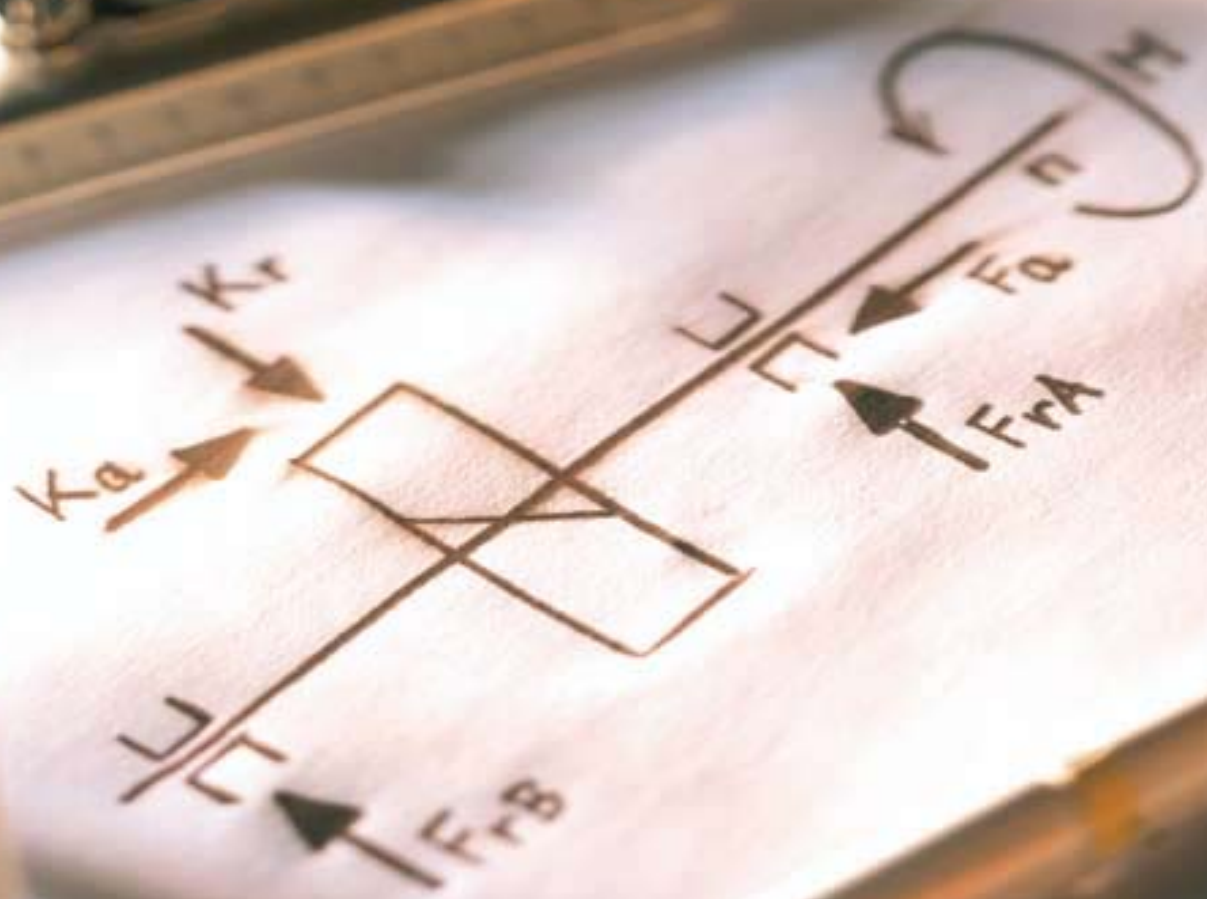

Principles of bearing selection and application

Bearing types	23
Selection of bearing type	33
Selection of bearing size	49
Friction	87
Speeds and vibration	107
Bearing data – general	117
Application of bearings	159
Lubrication	229
Mounting and dismounting	257
Reliability and services	275

Principles of bearing selection and application

A bearing arrangement consists of more than just the bearings. Associated items such as the shaft and housing are integral parts of the overall assembly arrangement. The importance of lubricant and sealing elements cannot be overestimated. Deploying a full bearing's performance relies on the presence of appropriate lubrication and adequate protection from corrosion and the ingress into the assembly of foreign matter. Cleanliness has a profound effect on bearing service life – which is why lubricants and seals have become part of the SKF business. To design a rolling bearing arrangement it is necessary

- to select a suitable bearing type
- to determine a suitable bearing size,

but that is not all. Several other aspects have to be considered, such as

- a suitable form and design of other components of the arrangement
- appropriate fits and bearing internal clearance or preload
- holding devices
- adequate seals
- the type and quantity of lubricant
- installation and removal methods, etc.

Each individual decision affects the performance, reliability and economy of the bearing arrangement.

The amount of work entailed depends on whether experience is already available about similar arrangements. When experience is lacking, when extraordinary demands are made or, when the costs of the bearing arrangement and any subsequent outline have to be given special consideration, then much more work is needed including, for example, more accurate calculations and/or testing.

As the leading bearing supplier SKF manufactures a large number of bearing types, series, designs, variants and sizes. The most common of them are introduced in the section “Product index”, starting on **page 1121**. There are also bearings which are not included in this catalogue. Information about most of these bearings can be found in special catalogues or in the “SKF Interactive Engineering Catalogue” on CD-ROM or online at www.skf.com.

In the following sections of this general technical introduction, the designer of a bearing arrangement can find the necessary basic information presented in the order in which it is generally required. Obviously it is impossible to include all the information needed to cover every conceivable bearing application. For this reason, in many places, reference is made to the comprehensive SKF application engineering service, which includes technical support about the selection of the right bearing as well as calculations of the complete bearing arrangement. The higher the technical demands placed on a bearing arrangement and the more limited the available experience of using bearings for particular applications, the more advisable it is to make use of this service.

The information contained in the general technical section generally applies to rolling bearings, or at least to a group of bearings. Special information specific to one bearing type only can be found in the text preceding the appropriate individual product section. Additional special catalogues and brochures covering specific application areas are available on request. Detailed information on almost all SKF rolling bearings, bearing units, bearing housings, plain bearings, seals etc. can also be found in the “SKF Interactive Engineering Catalogue” on CD-ROM or online at www.skf.com.

It should be noted that the values provided in the product tables for load and speed ratings as well as for the fatigue load limit are heavily rounded.

Bearing terminology

To better understand frequently used bearing terms, definitions are provided on **pages 20** and **21** and explained with the help of drawings. A detailed collection of bearing specific terms and definitions can be found in ISO 5593:1997: Rolling bearings – Vocabulary.

Product index

The product range shown in this General Catalogue comprises approximately 10 000 bearings, bearing accessories and bearing housings. So that users can find the technical data for a product known only by its designation, e.g. 6208-2RS1, the series designations are listed in the index starting on **page 1121**. In this case 62-2RS1 is used. Designations in this index are in alphanumerical order. The page listing for each designation refers to the product table where the particular product type appears for the first time.

Bearing terminology

Bearing arrangement (→ fig. 1)

- 1 Cylindrical roller bearing
- 2 Four-point contact ball bearing
- 3 Housing
- 4 Shaft
- 5 Shaft abutment shoulder
- 6 Shaft diameter
- 7 Locking plate
- 8 Radial shaft seal
- 9 Distance ring
- 10 Housing bore diameter
- 11 Housing bore
- 12 Housing cover
- 13 Snap ring

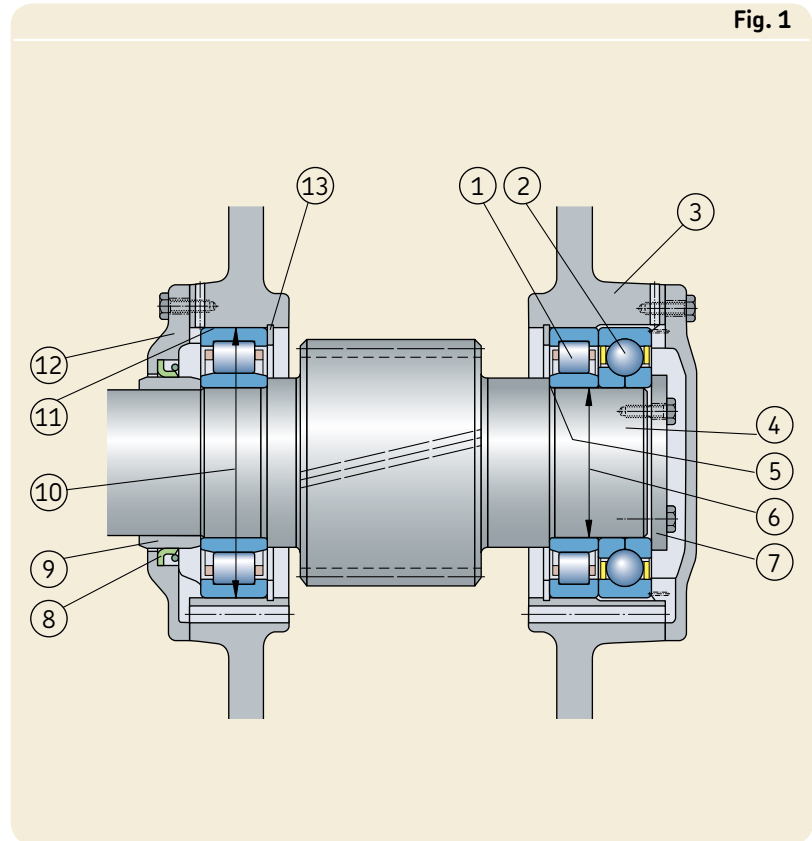

Radial bearings (→ figs. 2 and 3)

- 1 Inner ring
- 2 Outer ring
- 3 Rolling element: ball, cylindrical roller, needle roller, tapered roller, spherical roller
- 4 Cage
- 5 Capping device
- Seal – made of elastomer, contact (shown in figure) or non-contact
- Shield – made of sheet steel, non-contact
- 6 Outer ring outside diameter
- 7 Inner ring bore
- 8 Inner ring shoulder diameter
- 9 Outer ring shoulder diameter
- 10 Snap ring groove
- 11 Snap ring
- 12 Outer ring side face
- 13 Seal anchorage groove
- 14 Outer ring raceway
- 15 Inner ring raceway

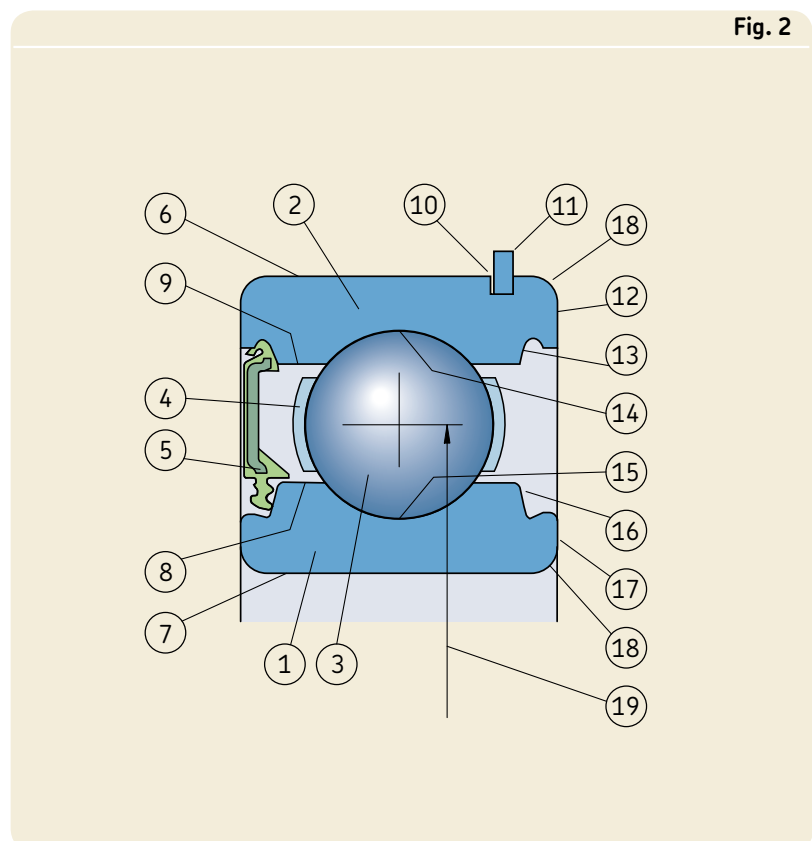
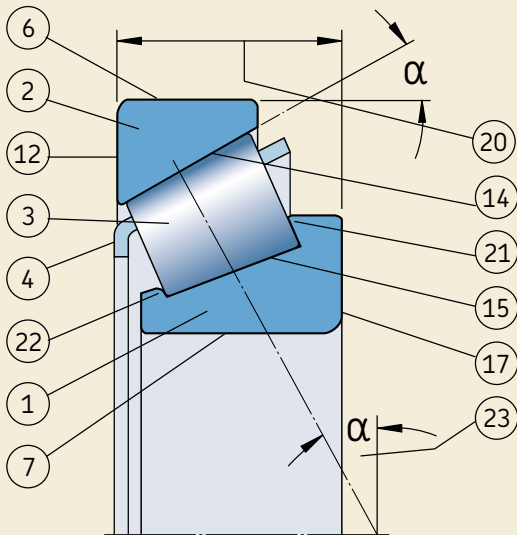
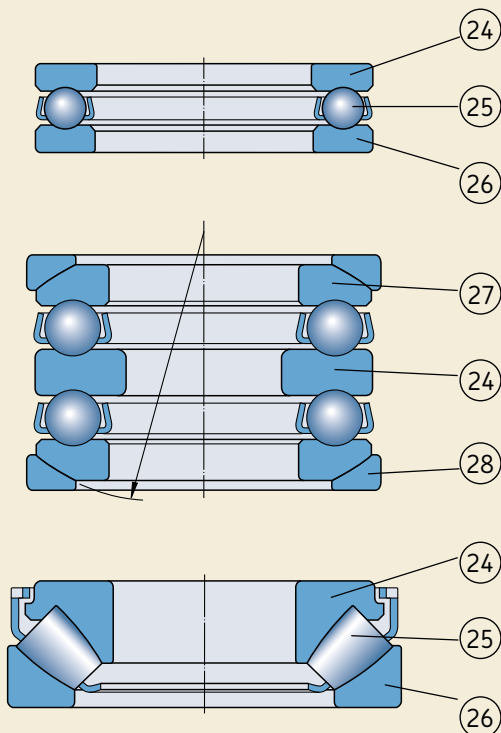

Fig. 3



- 16 Sealing groove
- 17 Inner ring side face
- 18 Chamfer
- 19 Bearing mean diameter
- 20 Total bearing width
- 21 Guiding flange
- 22 Retaining flange
- 23 Contact angle

Fig. 4



Thrust bearings (→ fig. 4)

- 24 Shaft washer
- 25 Rolling element and cage assembly
- 26 Housing washer
- 27 Housing washer with sphered seating surface
- 28 Seating support washer

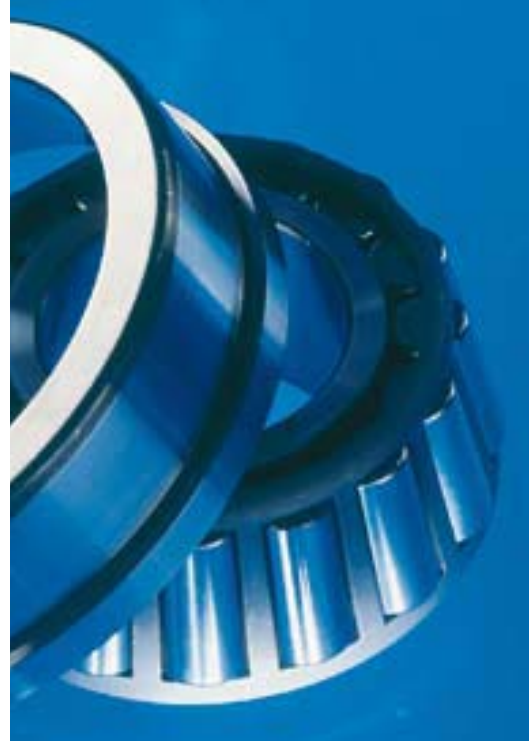

Bearing types

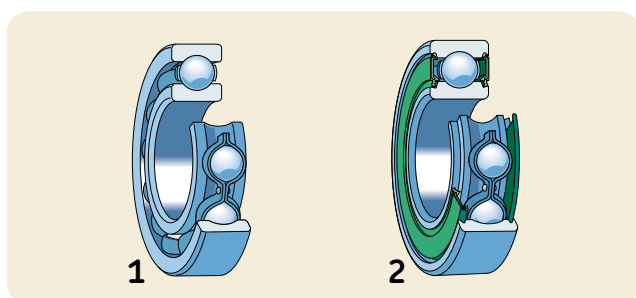

Radial bearings

Deep groove ball bearings

- single row, with or without filling slots
- open basic design (1)
- with shields
- with contact seals (2)
- with a snap ring groove, with or without a snap ring

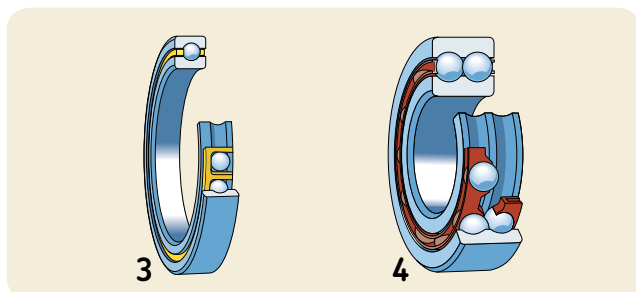

- single row with a fixed section
- open basic design (3)
- with contact seals
- double row (4)

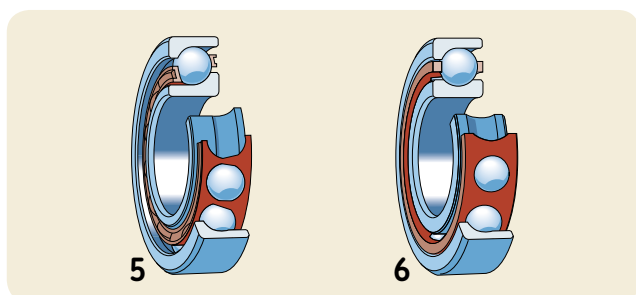

Angular contact ball bearings

- single row
 - basic design for single mounting
 - design for universal matching (5)
- single row high-precision¹⁾
 - basic design for single mounting (6)
 - design for universal matching
 - matched bearing sets

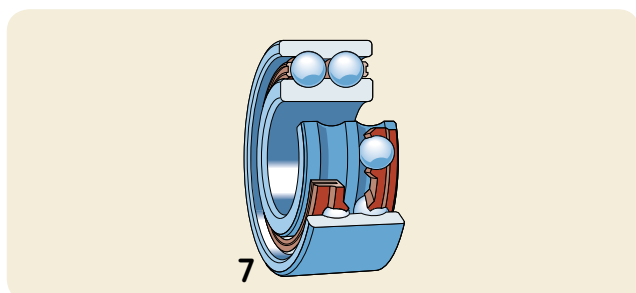

- double row
 - with a one-piece inner ring (7)
 - open basic design
 - with shields
 - with contact seals
 - with a two-piece inner ring

Footnote → page 31

Bearing types

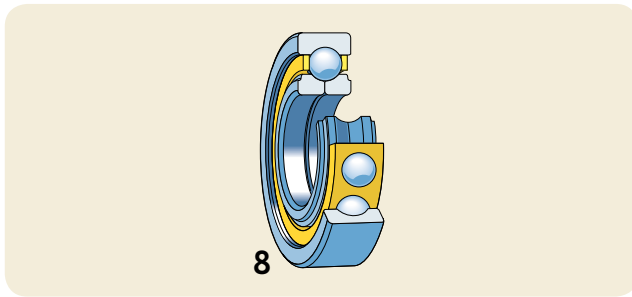

Radial bearings

Four-point contact ball bearings (8)

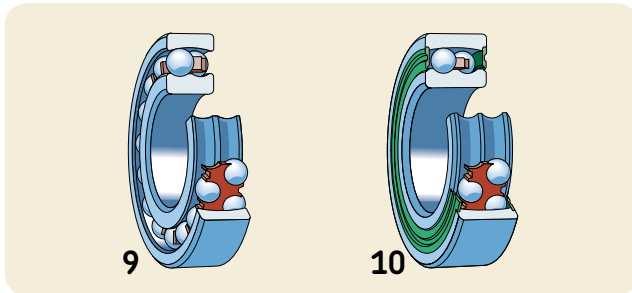

Self-aligning ball bearings
with a cylindrical or tapered bore
open basic design (9)
with contact seals (10)

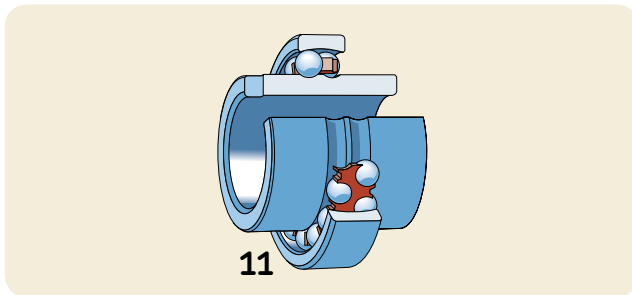

with an extended inner ring (11)

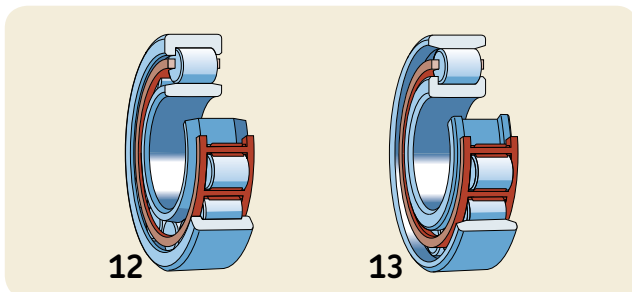

Cylindrical roller bearings

single row
NU design (12)
N design (13)

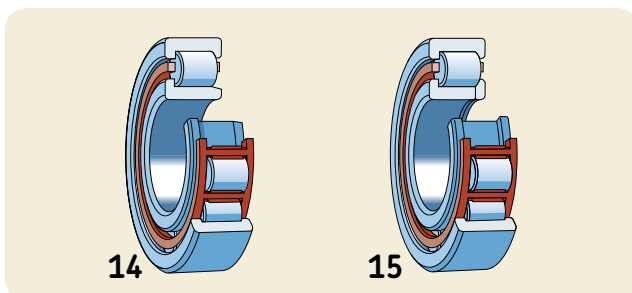

NJ design (14)
NUP design (15)

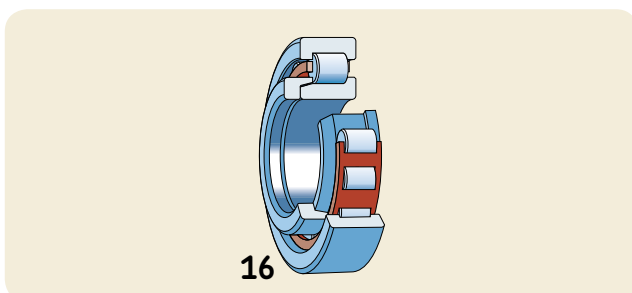

angle ring (16)
for NU and NJ design bearings

Radial bearings

Cylindrical roller bearings

double row¹⁾

with a cylindrical or tapered bore

NNU design (17)

NN design (18)

NNUP design

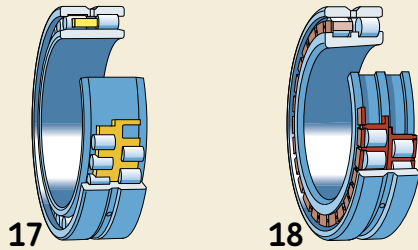

four-row²⁾

with a cylindrical or tapered bore

open design (19)

with contact seals

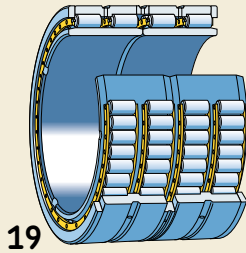

Full complement cylindrical roller bearings

single row

NCF design (20)

NJG design (21)

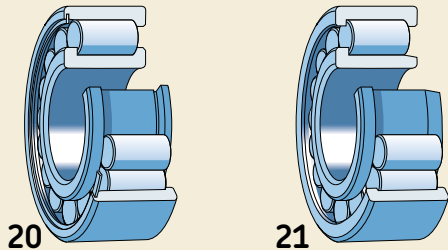

double row

with integral flanges on the inner ring (22)

with integral flanges on the inner and

outer rings

with contact seals (23)

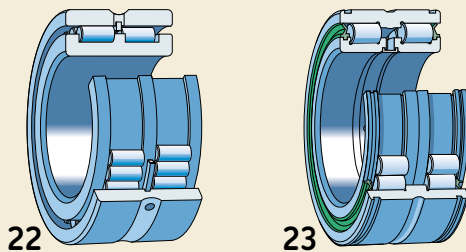

Needle roller and cage assemblies³⁾

single row (24)

double row (25)

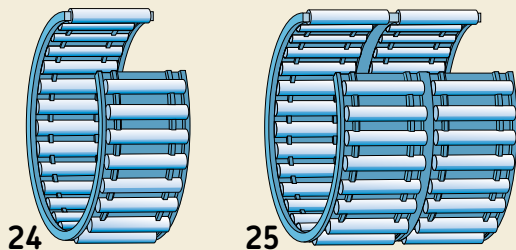

Drawn cup needle roller bearings, open ends³⁾

single and double row

open basic design (26)

with contact seals (27)

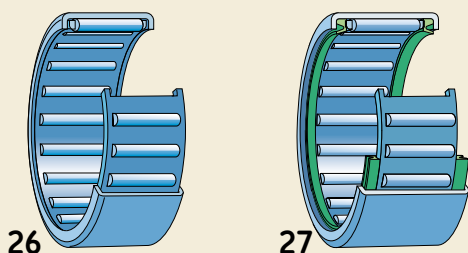

Footnote → page 31

Bearing types

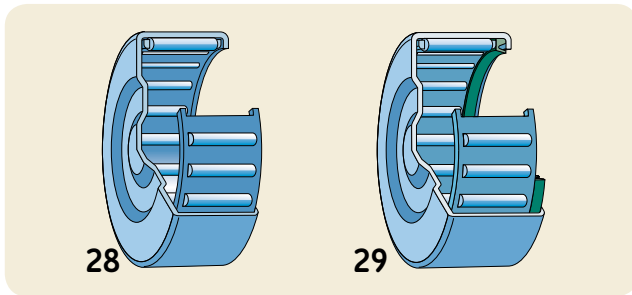

Radial bearings

Drawn cup needle roller bearings, closed end³⁾

single and double row
open basic design (28)
with a contact seal (29)

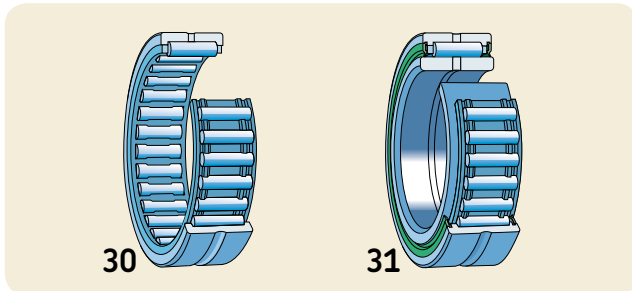

Needle roller bearings with flanges³⁾

single and double row
without an inner ring (30)
with an inner ring
open basic design
with contact seals (31)

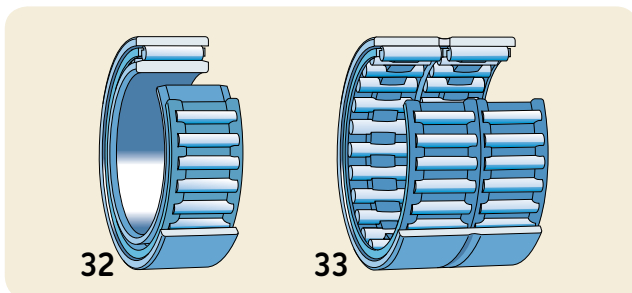

Needle roller bearings without flanges³⁾

single and double row
with an inner ring (32)
without an inner ring (33)

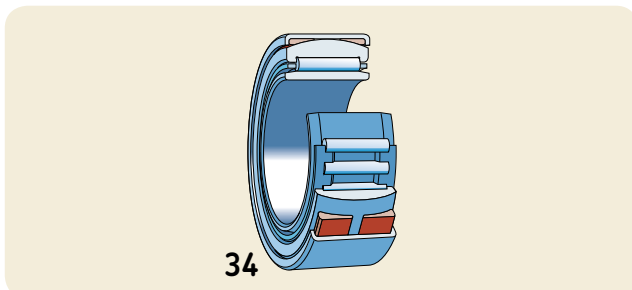

Alignment needle roller bearings³⁾

without an inner ring
with an inner ring (34)

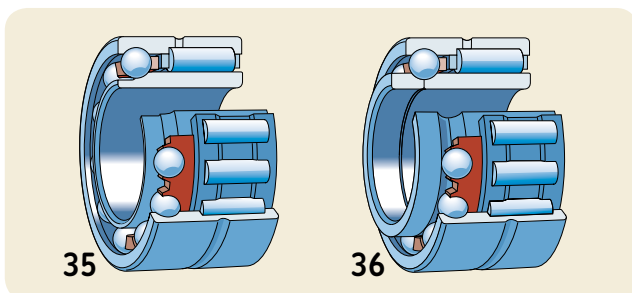

Combined needle roller bearings³⁾

Needle roller/angular contact ball bearings
single direction (35)
double direction (36)

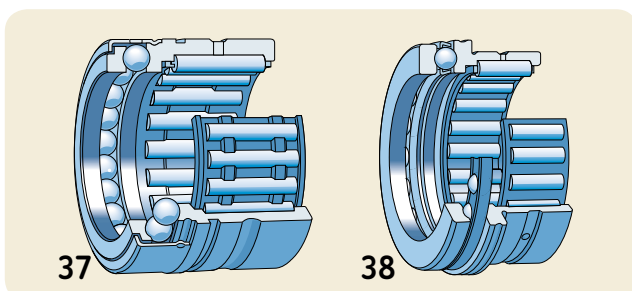

Needle roller/thrust ball bearings
with a full complement thrust ball bearing (37)
with a cage-guided ball set
with or without (38) a cover

Footnote → page 31

Radial bearings

Needle roller/cylindrical roller thrust bearings
without a cover (39)
with a cover (40)

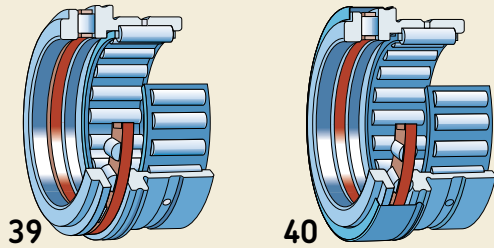

Taper roller bearings

single row
single bearings (41)
matched bearing sets
face-to-face (42)
back-to-back
in tandem

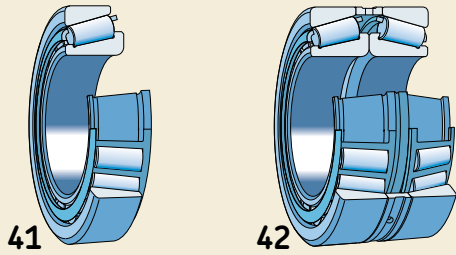

double row²⁾
TDO configuration (back-to-back) (43)
TDI configuration (face-to-face) (44)

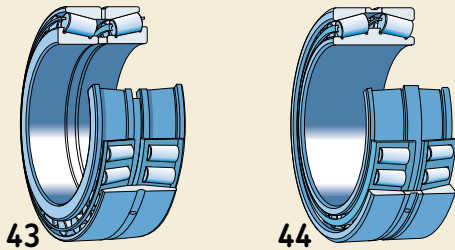

four-row²⁾
TQO configuration (45)
TQI configuration

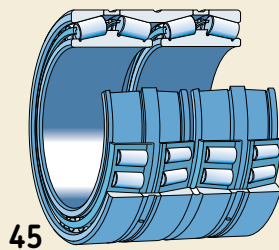

Spherical roller bearings

with a cylindrical or tapered bore
open basic designs (46)
with contact seals (47)

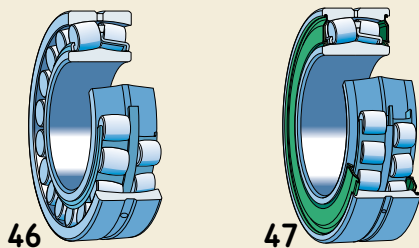

CARB toroidal roller bearings

with a cylindrical or tapered bore
open basic designs
with a cage-guided roller set (48)
with a full complement roller set
with contact seals (49)

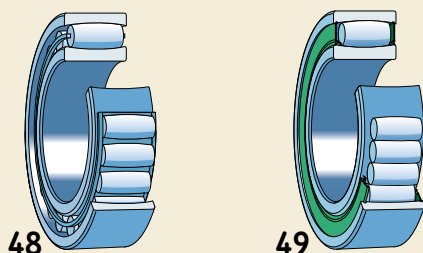

Footnote → page 31

Bearing types

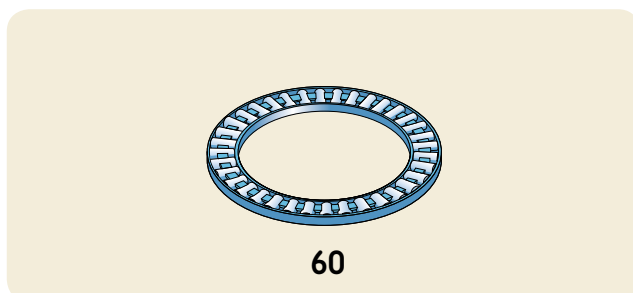
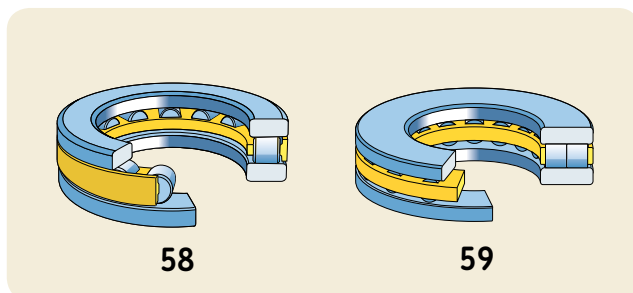
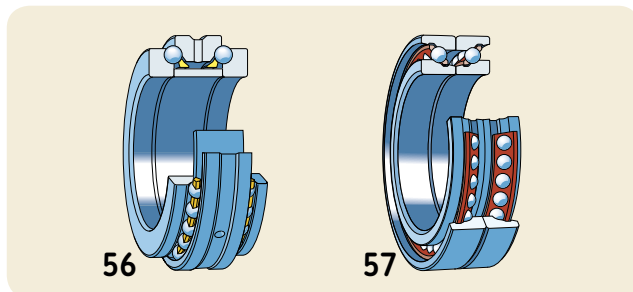
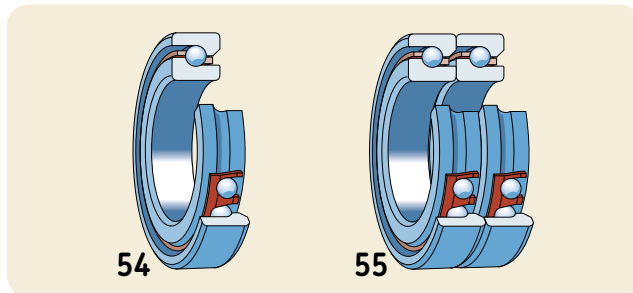
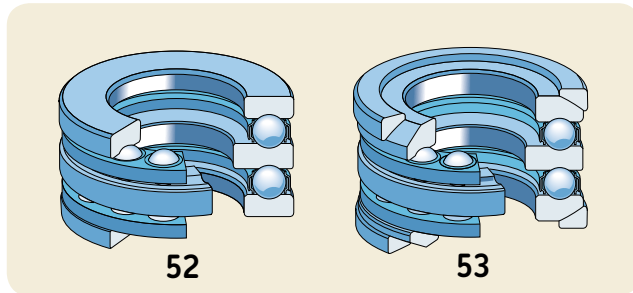
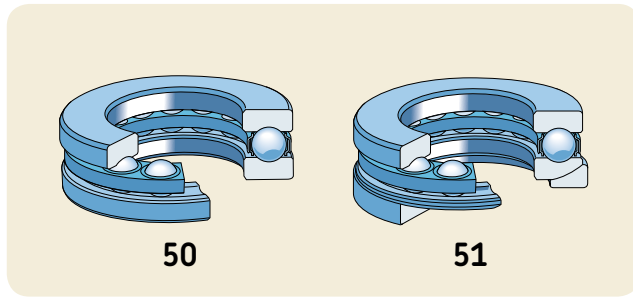

Thrust bearings

Thrust ball bearings

single direction

with a flat housing washer (50)

with a sphered housing washer

with (51) or without a seating washer

double direction

with flat housing washers (52)

with sphered housing washers

with (53) or without seating washers

Angular contact thrust ball bearings¹⁾

high-precision bearings

single direction

basic design for single mounting (54)

design for universal matching

matched bearing sets (55)

double direction

standard design (56)

high-speed design (57)

Cylindrical roller thrust bearings

single direction

single row (58)

double row (59)

components

cylindrical roller and cage thrust assemblies

shaft and housing washers

Needle roller thrust bearings³⁾

single direction (60)

needle roller and cage thrust assemblies

raceway washers

thrust washers

Footnote → page 31

Thrust bearings

Spherical roller thrust bearings
single direction (**61**)

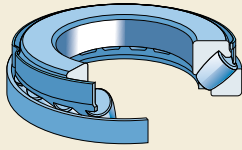

61

Taper roller thrust bearings²⁾
single direction
with or without (**62**) a cover
screw down bearings
double direction (**63**)

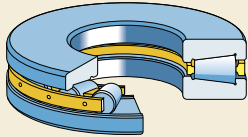

62

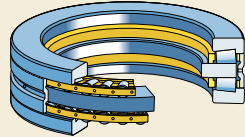

63

Footnote → page 31

Bearing types

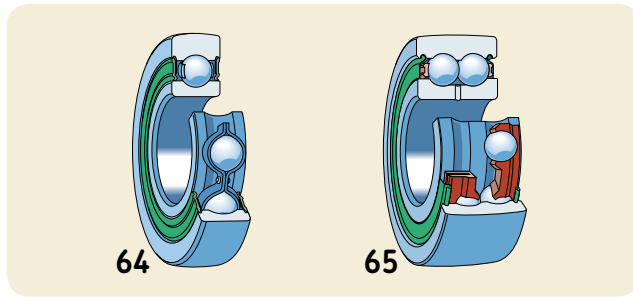

Track runner bearings

Cam rollers

- single row ball bearing cam roller (64)
- double row ball bearing cam roller (65)

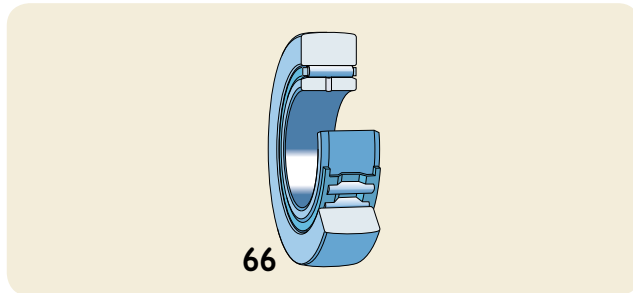

Support rollers³⁾

- without an axial guidance
- with or without contact seals
- without an inner ring
- with an inner ring (66)

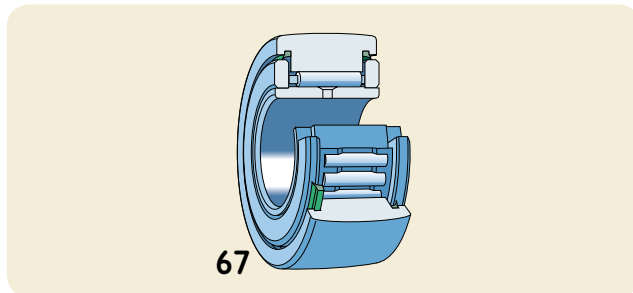

- with an axial guidance by thrust washers
- with or without contact seals
- with a cage-guided needle roller set (67)
- with a full complement needle roller set

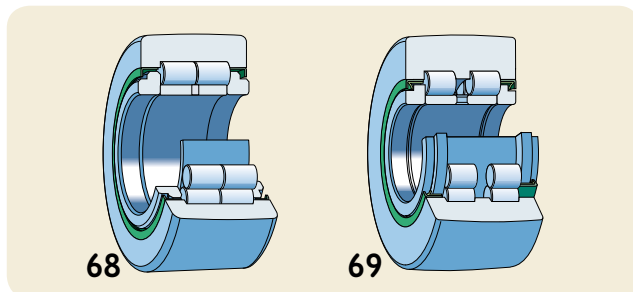

- with an axial guidance by cylindrical rollers
- with labyrinth seals (68)
- with contact seals (69)
- with lamellar seals

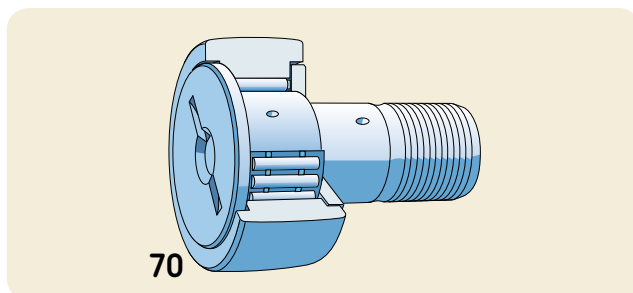

Cam followers³⁾

- with an axial guidance by thrust plate
- with or without contact seals
- with a concentric seating (70)
- with an eccentric seating collar
- with a cage-guided needle roller set (70)
- with a full complement needle roller set

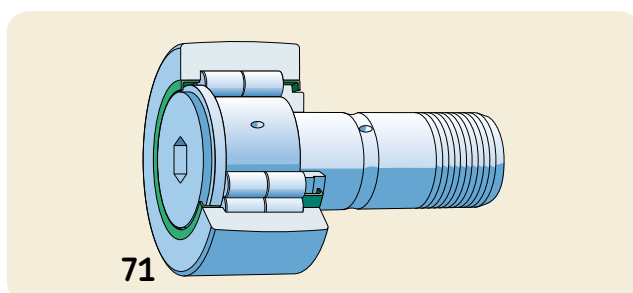

- with an axial guidance by cylindrical rollers
- with labyrinth seals (71)
- with contact seals
- with a concentric seating (71)
- with an eccentric seating collar

Footnote → page 31

Y-bearings

Y-bearings (insert bearings)⁴⁾

with grub screws

inner ring extended on one side (**72**)

inner ring extended on both sides (**73**)

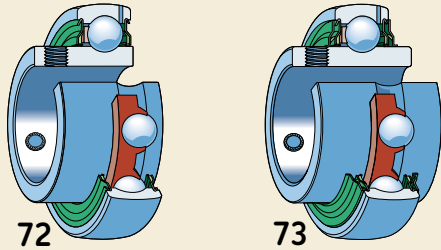

with an eccentric locking collar

inner ring extended on one side (**74**)

inner ring extended on both sides (**75**)

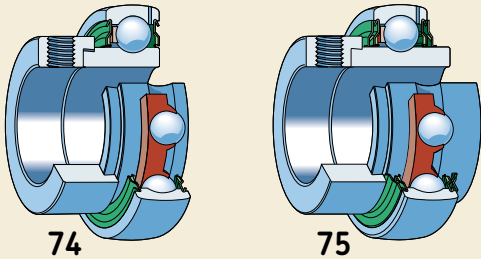

with a tapered bore

inner ring extended on both sides (**76**)

for adapter sleeve mounting

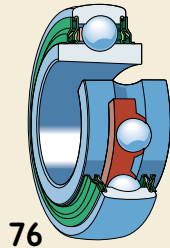

with a standard inner ring

for locating by interference fit on the shaft (**77**)

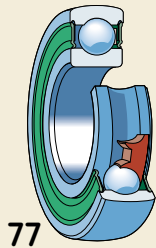

with a hexagonal bore (**78**)

with a square bore

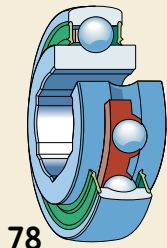

¹⁾ See SKF catalogue "High-precision bearings" or "SKF Interactive Engineering Catalogue"

²⁾ See "SKF Interactive Engineering Catalogue"

³⁾ See SKF catalogue "Needle roller bearings" or "SKF Interactive Engineering Catalogue"

⁴⁾ See SKF catalogue "Y-bearings and Y-bearing units" or "SKF Interactive Engineering Catalogue"

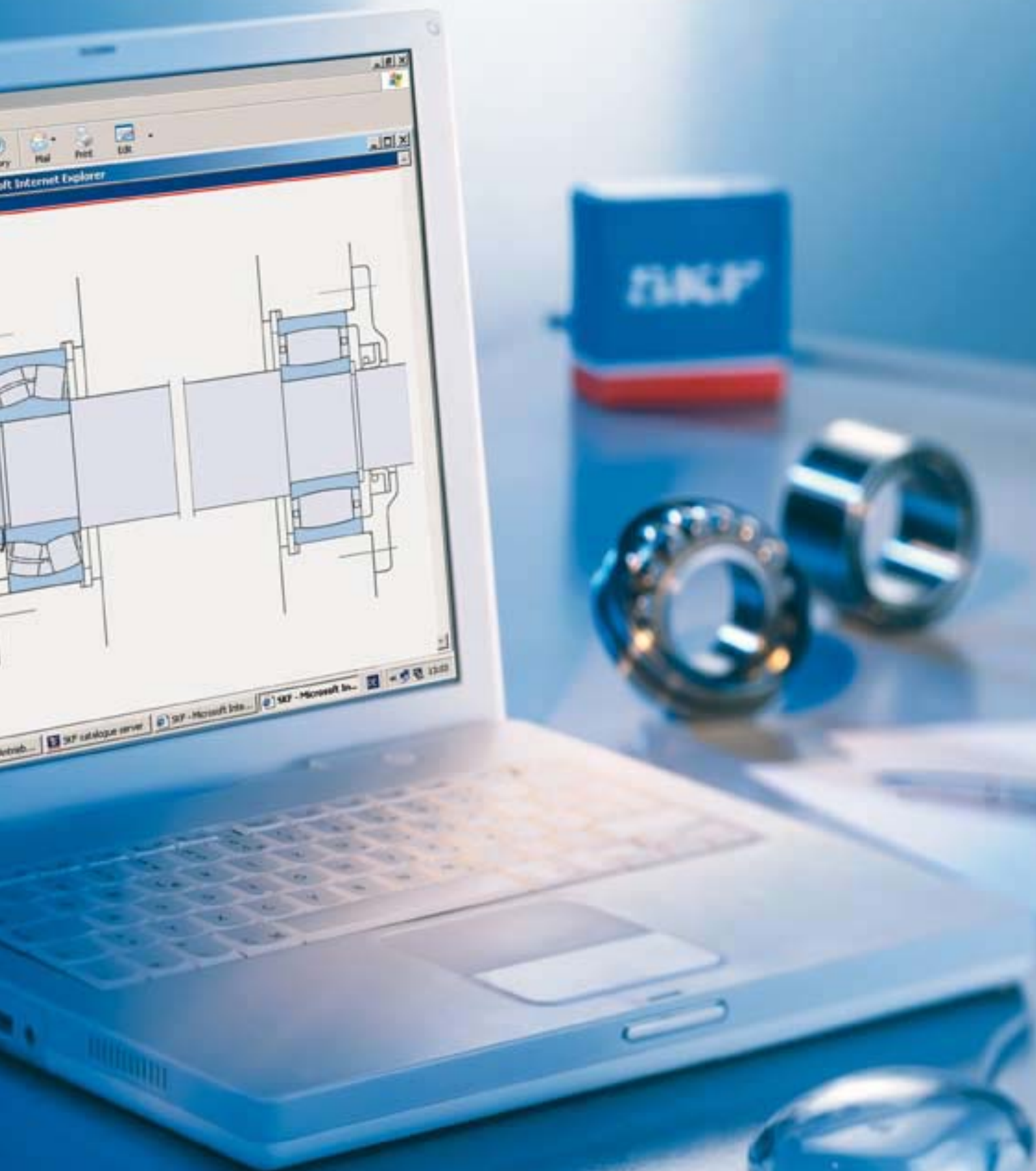

Selection of bearing type

Available space	35
Loads	37
Magnitude of load.....	37
Direction of load	37
Misalignment	40
Precision	40
Speed	42
Quiet running	42
Stiffness	42
Axial displacement	43
Mounting and dismounting	44
Cylindrical bore	44
Tapered bore.....	44
Integral seals	45
Matrix: Bearing types – design and characteristics	46

Selection of bearing type

Each bearing type displays characteristic properties, based on its design, which makes it more, or less, appropriate for a given application. For example, deep groove ball bearings can accommodate moderate radial loads as well as axial loads. They have low friction and can be produced with high precision and in quiet running variants. Therefore they are preferred for small and medium-sized electric motors.

Spherical and toroidal roller bearings can carry very heavy loads and are self-aligning. These properties make them popular for example for heavy engineering applications, where there are heavy loads, shaft deflections and misalignments.

In many cases, however, several factors have to be considered and weighed against each other when selecting a bearing type, so that no general rules can be given. The information provided here should serve to indicate which are the most important factors to be considered when selecting a standard bearing type and thus facilitate an appropriate choice

- available space
- loads
- misalignment
- precision
- speed
- quiet running
- stiffness
- axial displacement
- mounting and dismounting
- integral seals.

A comprehensive overview of the standard bearing types, their design characteristics and their suitability for the demands placed on a given application can be found in the matrix on **pages 46 and 47**. Detailed information on the individual bearing types, including their characteristics and the available designs, can be found in the sections dealing with individual bearing types. Bearing types that are not included in the matrix are generally only used for a few well-defined applications.

The matrix permits only a relatively superficial classification of bearing types. The limited number of symbols does not allow an exact differentiation and some properties do not depend solely on bearing design. For example, the stiffness of an arrangement incorporating angular contact ball bearings or taper roller bearings

also depends on the applied preload and the operating speed, which is influenced by the precision of the bearing and its associated components as well as by the cage design. In spite of its limitations, the matrix on **pages 46 and 47** should enable an appropriate choice of bearing type to be made. It should also be considered that the total cost of a bearing arrangement and inventory considerations could also influence the final choice.

Other important criteria to be observed when designing a bearing arrangement including load carrying capacity and life, friction, permissible speeds, bearing internal clearance or preload, lubrication and sealing are dealt with in depth in separate sections of this catalogue.

The complete SKF product range is not shown in this General Catalogue. Specific catalogues and brochures are available for bearings not covered here – please consult SKF.

Available space

In many cases, one of the principal dimensions of a bearing – the bore diameter – is predetermined by the machine's design and the shaft diameter.

For small-diameter shafts all types of ball bearings can be used, the most popular being deep groove ball bearings; needle roller bearings are also suitable (→ **fig. 1**). For large-diameter shafts, cylindrical, taper, spherical and toroidal roller bearings are available, as well as deep groove ball bearings (→ **fig. 2**).

When radial space is limited, bearings with a small cross section, particularly those with a low cross-sectional height, should be chosen, i.e. bearings in the 8 or 9 Diameter Series. Needle roller and cage assemblies, drawn cup needle roller bearings and needle roller bearings without or even with an inner ring (→ **fig. 3**) are very appropriate (→ SKF catalogue "Needle roller bearings"), as well as certain series of deep groove and angular contact ball bearings, cylindrical, taper, spherical and toroidal roller bearings.

Fig. 1

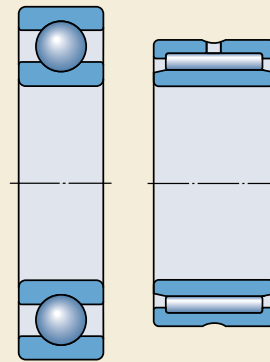

Fig. 2

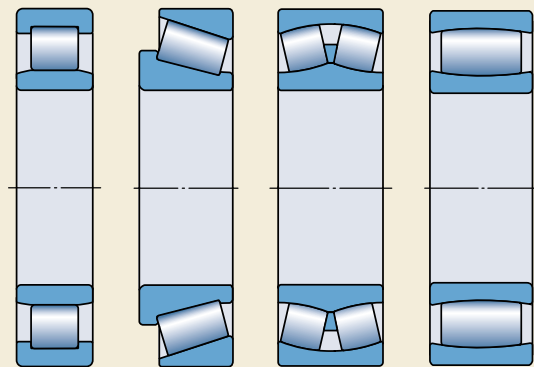
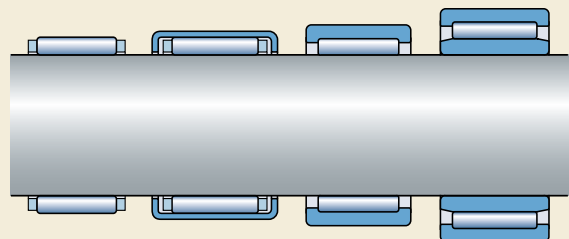

Fig. 3



Selection of bearing type

When axial space is limited, certain series of cylindrical roller bearings and deep groove ball bearings can be used for radial or combined loads respectively (→ **fig. 4**), as well as the various types of combined needle roller bearings (→ **fig. 5**). For purely axial loads, needle roller and cage thrust assemblies (with or without washers) as well as thrust ball bearings and cylindrical roller thrust bearings can be used (→ **fig. 6**).

Fig. 4

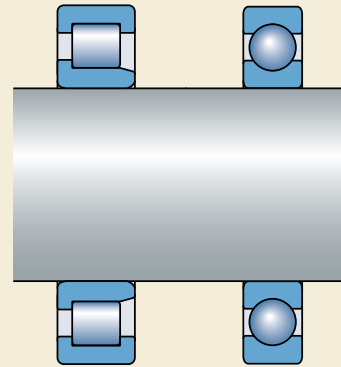

Fig. 5

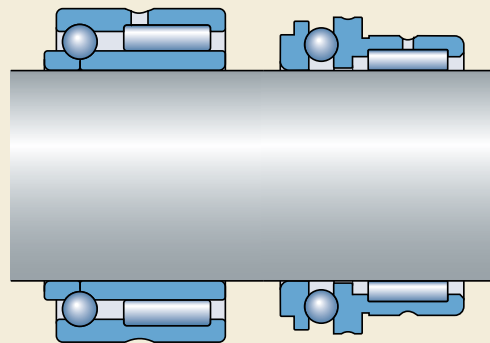

Fig. 6

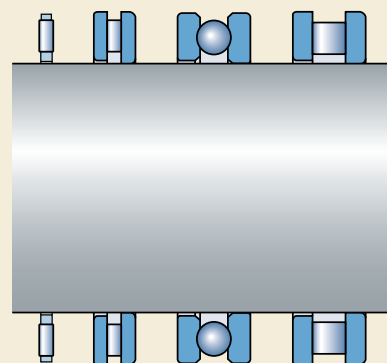
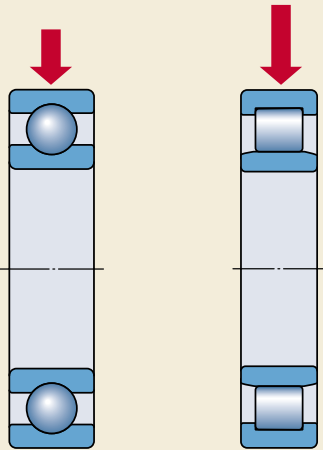

Fig. 7



Loads

Magnitude of load

The magnitude of the load is one of the factors that usually determines the size of the bearing. Generally, roller bearings are able to support heavier loads than similar sized ball bearings (→ **fig. 7**) and bearings having a full complement of rolling elements can accommodate heavier loads than the corresponding caged bearings. Ball bearings are mostly used where loads are light or moderate. For heavy loads and where shaft diameters are large, roller bearings are usually the more appropriate choice.

Direction of load

Fig. 8

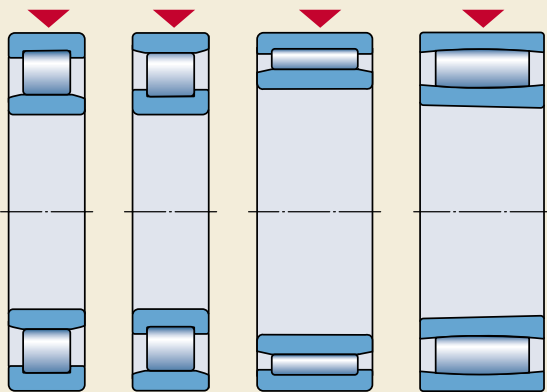

Radial load

NU and N design cylindrical roller bearings, needle roller bearings and toroidal roller bearings can only support pure radial loads (→ **fig. 8**). All other radial bearings can accommodate some axial loads in addition to radial loads (→ “Combined load”).

Axial load

Thrust ball bearings and four-point contact ball bearings (→ **fig. 9**) are suitable for light or moderate loads that are purely axial. Single direction thrust ball bearings can only accommodate axial loads acting in one direction; for axial loads acting in both directions, double direction thrust ball bearings are needed.

Fig. 9

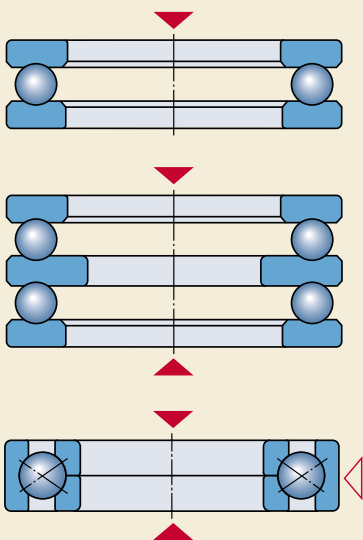
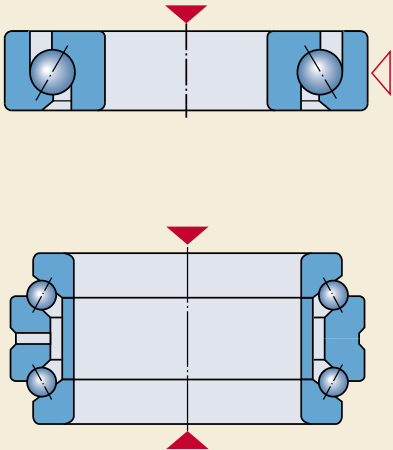

Fig. 10



Angular contact thrust ball bearings can support moderate axial loads at high speeds; here, the single direction bearings can also accommodate simultaneously acting radial loads, while double direction bearings are normally used only for purely axial loads (→ fig. 10).

For moderate and heavy axial loads acting in one direction, needle roller thrust bearings, cylindrical and taper roller thrust bearings are suitable, as are spherical roller thrust bearings (→ fig. 11). Spherical roller thrust bearings can also accommodate simultaneously acting radial loads. For heavy alternating axial loads, two cylindrical roller thrust bearings or two spherical roller thrust bearings can be mounted adjacent to each other.

Combined load

A combined load comprises a radial and an axial load acting simultaneously. The ability of a bearing to carry an axial load is determined by the angle of contact α – the greater the angle, the more suitable the bearing for axial loads. An indication of this is given by the calculation factor Y , which becomes smaller as the contact angle α increases. The values of this factor for a bearing type or for individual bearings can be found in the introductory text of the product table sections, or in the actual product tables. The axial load carrying capacity of a deep groove ball bearing depends on its internal design and the internal clearance in the bearing (→ section “Deep groove ball bearings”, starting on page 287).

For combined loads, single and double row angular contact ball bearings and single row taper roller bearings are most commonly used, although deep groove ball bearings and spherical roller bearings are suitable (→ fig. 12). In addition, self-aligning ball bearings and NJ and NUP design cylindrical roller bearings as well as NJ and NU design cylindrical roller bearings with HJ angle rings can be used for combined loads where the axial component is relatively small (→ fig. 13).

Single row angular contact ball bearings, taper roller bearings, NJ design cylindrical roller bearings, NU design cylindrical roller bearings + HJ angle ring and spherical roller thrust bearings can accommodate axial loads acting in one direction only. For axial loads of alternating direction these bearings must be combined

Fig. 11

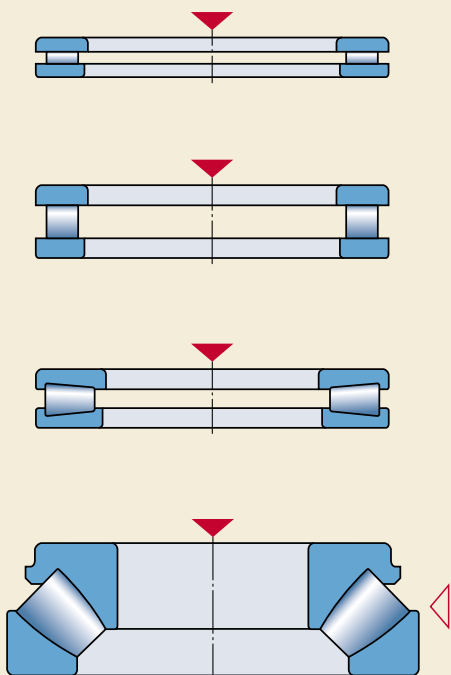
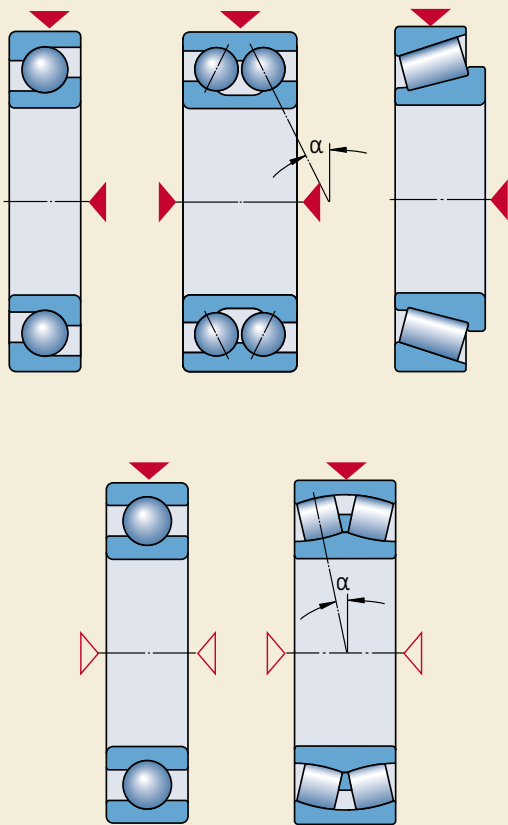

Fig. 12



with a second bearing. For this reason, single row angular contact ball bearings are available as bearings for universal matching and single row taper roller bearings can be supplied as matched sets comprising two single row bearings (→ sections “Single row angular contact ball bearings”, starting on **page 409**, and “Paired single row taper roller bearings”, starting on **page 671**).

When the axial component of combined loads is large, it may be supported independently from the radial load by a separate bearing. In addition to thrust bearings, some radial bearings, e.g. deep groove ball bearings or four-point contact ball bearings (→ **fig. 14**) are suitable for this task. To make sure that the bearing is only subjected to the axial load in such cases, the bearing outer ring must be mounted with radial clearance.

Fig. 13

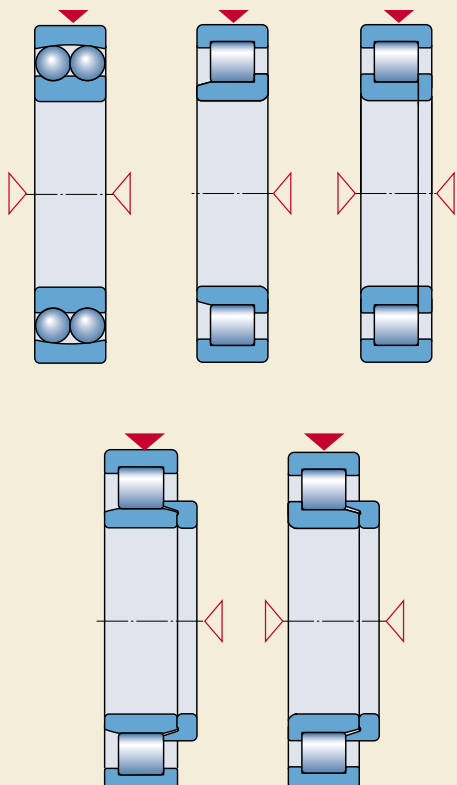
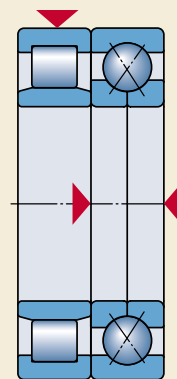

Fig. 14



Selection of bearing type

Moment load

When a load acts eccentrically on a bearing, a tilting moment will occur. Double row bearings, e.g. deep groove or angular contact ball bearings, can accommodate tilting moments, but paired single row angular contact ball bearings or taper roller bearings arranged face-to-face, or better still back-to-back, are more suitable (→ **fig. 15**).

Misalignment

Angular misalignments between the shaft and housing occur, for example, when the shaft bends (flexes) under the operating load, when the bearing seatings in the housing are not machined to the same height or when shafts are supported by bearings in separate housings that are too far apart.

Rigid bearings, i.e. deep groove ball bearings and cylindrical roller bearings cannot accommodate any misalignment, or can only accommodate very minor misalignments, unless by force. Self-aligning bearings, i.e. self-aligning ball bearings, spherical roller bearings, toroidal roller bearings and spherical roller thrust bearings (→ **fig. 16**), on the other hand, can accommodate misalignment produced under operating loads and can also compensate for initial misalignment resulting from machining or mounting errors. Values for the permissible misalignments are provided in the introductory text of the table section. If the expected misalignment exceeds the permissible values, please contact the SKF application engineering service.

Thrust ball bearings with sphered housing washers and seating rings, Y-bearing units and alignment needle roller bearings (→ **fig. 17**) can compensate for initial misalignment arising from machining or mounting errors.

Precision

Bearings with higher precision than Normal are required for arrangements that must have high running accuracy (e.g. machine tool spindle arrangements) as well as those applications where very high speeds are required.

The introductory text to each table section contains information about the tolerance classes to which the bearings in that section are produced. SKF produces a comprehensive range of high-precision bearings, including single row angular contact ball bearings, single and double row cylindrical roller bearings and single and double direction angular contact thrust ball bearings (→ SKF catalogue “High-precision bearings”).

Fig. 15

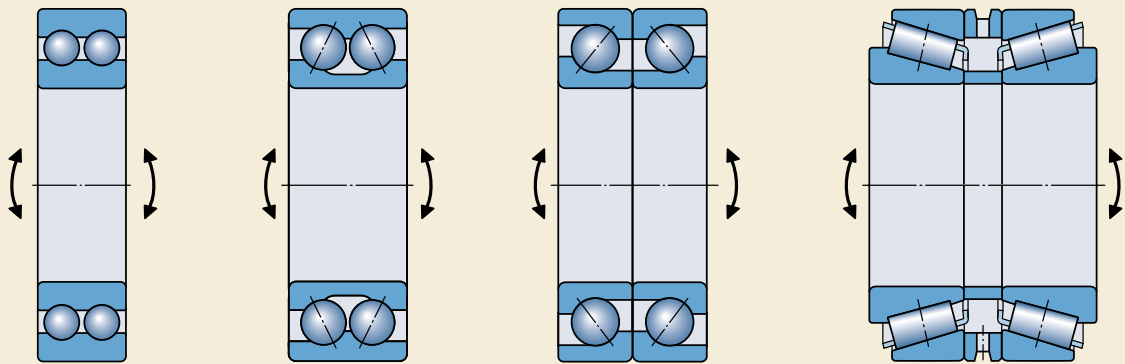

Fig. 16

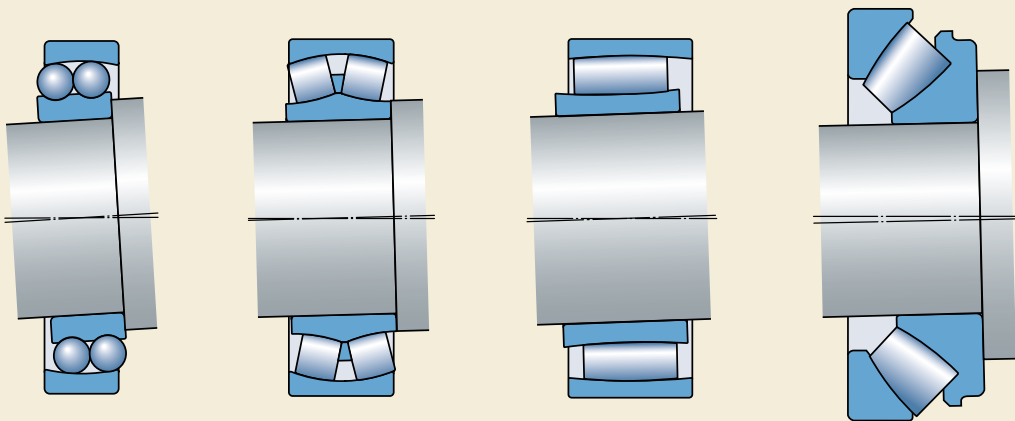
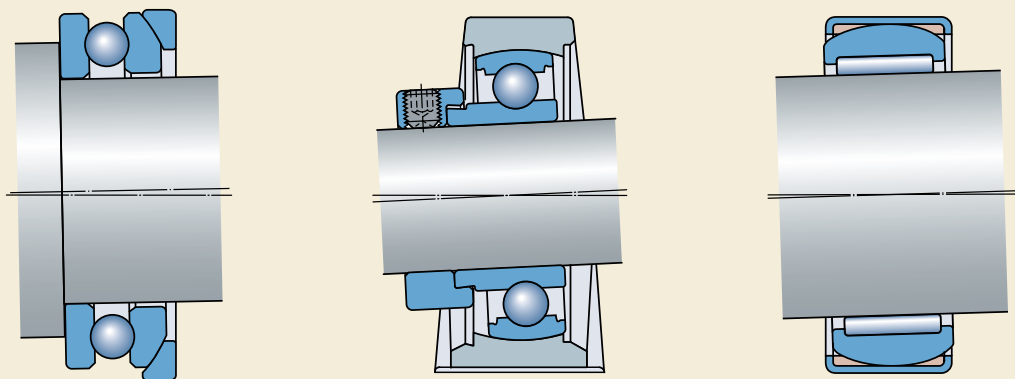

Fig. 17



Speed

The permissible operating temperature limits the speed at which rolling bearings can be operated. Bearing types with low friction and correspondingly low heat generation inside the bearing are therefore the most suitable for high-speed operation.

The highest speeds can be achieved with deep groove ball bearings and self-aligning ball bearings (→ **fig. 18**) when loads are purely radial and with angular contact ball bearings (→ **fig. 19**) for combined loads. This is particularly true of high-precision angular contact ball bearings or deep groove ball bearings with ceramic rolling elements.

Because of their design, thrust bearings cannot accommodate as high speeds as radial bearings.

Quiet running

In certain applications, e.g. small electric motors for household appliances or office machinery, the noise produced in operation is an important factor and can influence the bearing choice. SKF deep groove ball bearings are produced specifically for these applications.

Stiffness

The stiffness of a rolling bearing is characterized by the magnitude of the elastic deformation (resilience) in the bearing under load. Generally, this deformation is very small and can be neglected. In some cases, however, e.g. spindle bearing arrangements for machine tools or pinion bearing arrangements, stiffness is important.

Because of the contact conditions between the rolling elements and raceways, roller bearings, e.g. cylindrical or taper roller bearings (→ **fig. 20**), have a higher degree of stiffness than ball bearings. Bearing stiffness can be further enhanced by applying a preload (→ section “Bearing preload”, starting on **page 206**).

Fig. 18

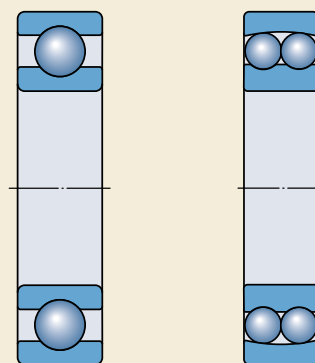

Fig. 19



Fig. 20

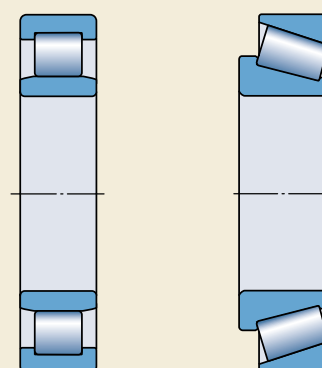
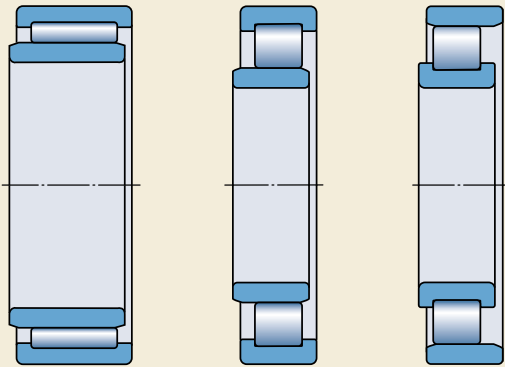

Fig. 21



Axial displacement

Shafts, or other rotating machine components, are generally supported by a locating and a non-locating bearing (→ section “Bearing arrangements”, starting on **page 160**).

Locating bearings provide axial location for the machine component in both directions. The most suitable bearings for this are those that can accommodate combined loads, or can provide axial guidance in combination with a second bearing (→ matrix on **pages 46 and 47**).

Non-locating bearings must permit shaft movement in the axial direction, so that the bearings are not overloaded when, for example, thermal expansion of the shaft occurs. The most suitable bearings for the non-locating position include needle roller bearings and NU and N design cylindrical roller bearings (→ **fig. 21**). NJ design cylindrical roller bearings and some full complement design cylindrical roller bearings can also be used.

In applications where the required axial displacement is relatively large and also the shaft may be misaligned, a CARB toroidal roller bearing (→ **fig. 22**).

All of these bearings permit axial displacement of the shaft with respect to the housing within the bearing. Values for the permissible axial displacement within the bearing are provided in the relevant product tables.

If non-separable bearings, e.g. deep groove ball bearings or spherical roller bearings (→ **fig. 23**) are used as non-locating bearings, one of the bearing rings must have a loose fit (→ section “Radial location of bearings”, starting on **page 164**).

Fig. 22

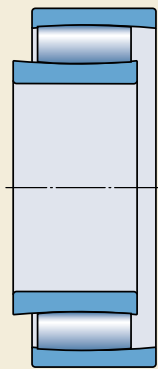
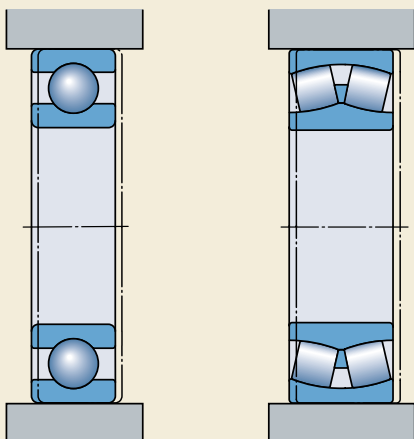

Fig. 23



Mounting and dismounting

Cylindrical bore

Bearings with a cylindrical bore are easier to mount and dismount if they are of separable design rather than non-separable, particularly if interference fits are required for both rings. Separable bearings are also preferable if frequent mounting and dismounting are required, because the ring with rolling element and cage assembly of these separable bearings can be fitted independently of the other ring, e.g. four-point contact ball bearings, cylindrical, needle and taper roller bearings (→ **fig. 24**), as well as ball and roller thrust bearings.

Tapered bore

Bearings with a tapered bore (→ **fig. 25**) can easily be mounted on a tapered journal or on a cylindrical shaft seating using an adapter or withdrawal sleeve (→ **fig. 26**).

Fig. 24

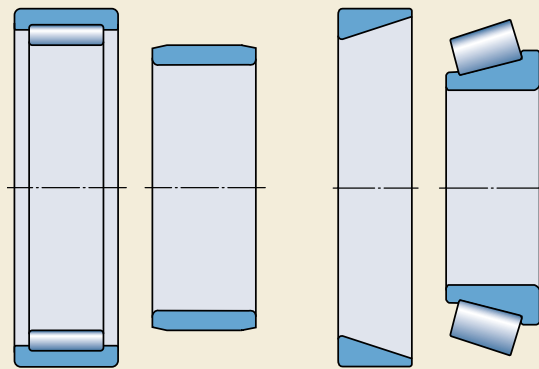
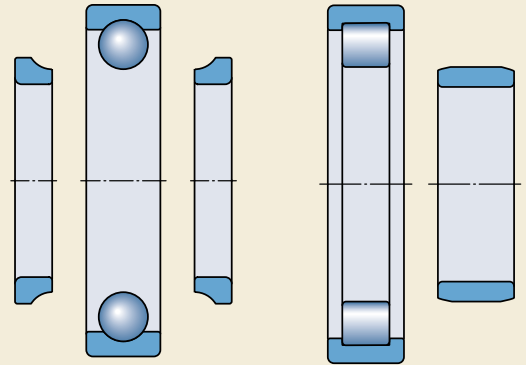

Fig. 25

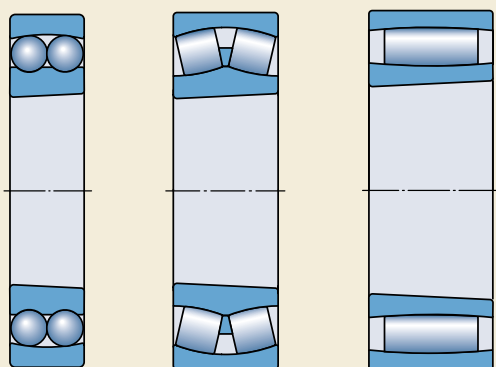
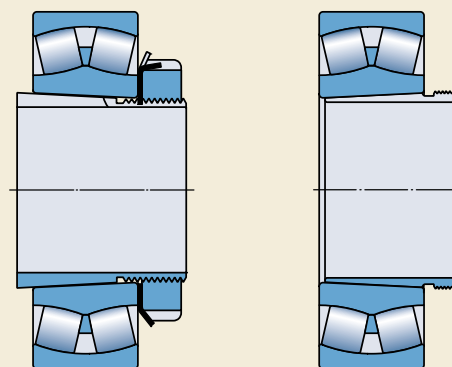

Fig. 26



Integral seals

The selection of a seal is of vital importance to the proper performance of the bearing. SKF supplies bearings with integral

- shields (→ **fig. 27**)
- low-friction seals (→ **fig. 28**)
- contact seals (→ **fig. 29**)

that can provide an economic and space-saving solution for many applications. A large number of sizes are available for

- deep groove ball bearings
- angular contact ball bearings
- self-aligning ball bearings
- cylindrical roller bearings
- needle roller bearings
- spherical roller bearings
- CARB toroidal roller bearings
- cam rollers
- Y-bearings and Y-bearing units.

All bearings with integral seals on both sides are filled with a grease of appropriate quality and quantity.

Fig. 27

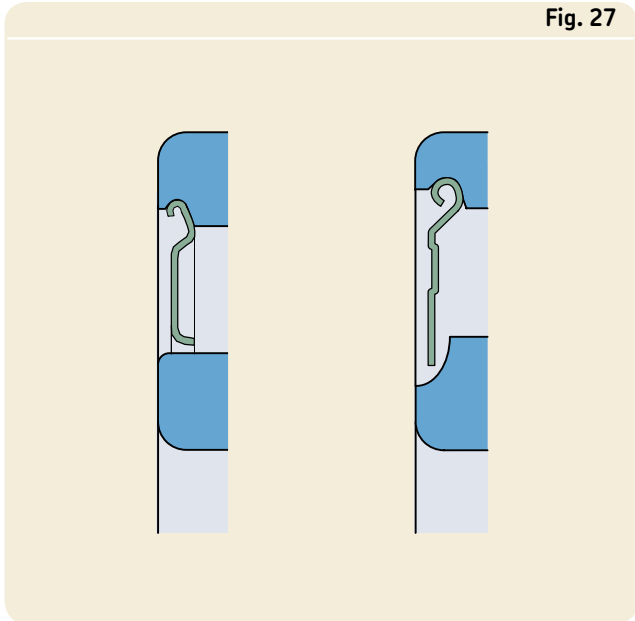

Fig. 28

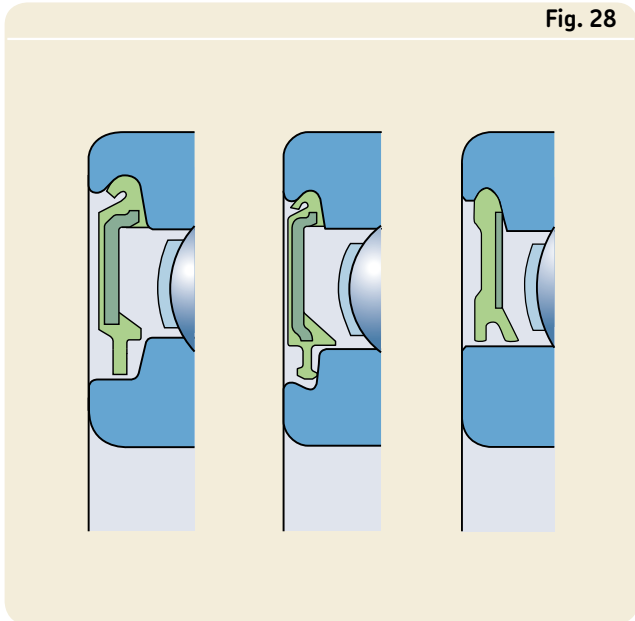
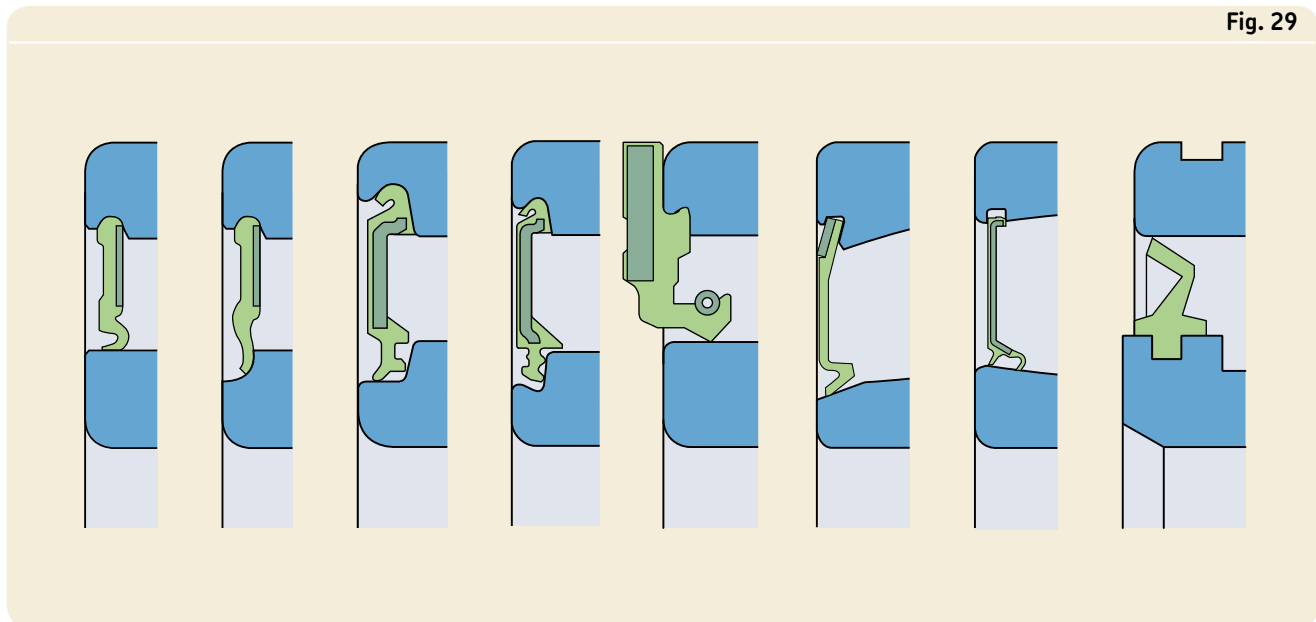

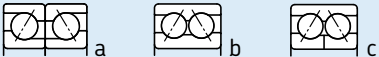

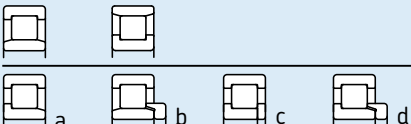

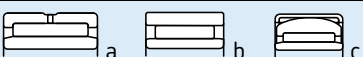
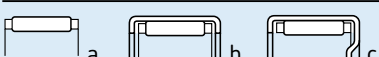
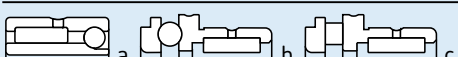

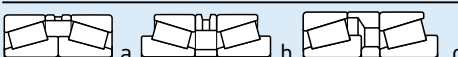









Fig. 29



Selection of bearing type

<p>The matrix can only provide a rough guide so that in each individual case it is necessary to make a more qualified selection referring to the information provided on the preceding pages or the detailed information in the text preceding each table section. If several designs of the bearing type are shown adjacent to each other, the relevant information is indicated by the same small letter used to identify the individual design.</p> <p>Symbols +++ excellent ++ good + fair - poor -- unsuitable ← single direction ↔ double direction</p>		Bearing types – design and characteristics				
		Design				
Bearing type		tapered bore	shields or seals	self-aligning	non-seperable	seperable
Deep groove ball bearings			a			
Angular contact ball bearings, single row						
matched single row, double row			b		a, b	c
four-point contact						
Self-aligning ball bearings						
Cylindrical roller bearings, with cage						
full complement, single row					a	b
full complement, double row			d			
Needle roller bearings, with steel rings			a			
assemblies/drawn cups			b, c			
combined bearings			b, c			
Taper roller bearings						
matched single row						
Spherical roller bearings						
CARB toroidal roller bearings, with cage						
full complement						
Thrust ball bearings						
with sphered housing washer						
Needle roller thrust bearings Cylindrical roller thrust bearings						
Spherical roller thrust bearings						

Characteristics
Suitability of bearings for

purely radial load	purely axial load	combined load	moment load	high speed	high running accuracy	high stiffness	quiet running	low friction	compensation for misalignment in operation	compensation for errors of alignment (initial)	locating bearing arrangements	non-locating bearing arrangements	axial displacement within bearing
+	↔	↔	a- b+	a+++ b+	a+++ b+	+	+++	+++	-	-	++ ↔	+	--
a+ b+++	a+ b+++	++ ←	-	a++ b+	a+++ b+++	+	a++ b+	a++ b+	-	-	++ ←	--	--
++	↔	↔	+	+	++	+	+	+	--	--	++ ↔	+	--
-	↔	↔	+	++	+	+	+	+	--	--	++ ↔	-	--
+	-	-	--	+++	++	-	++	+++	+++	+++	↔	+	--
++	--	--	--	++	++	++	++	++	-	-	--	+++	+++
++	a+ b← c↔	a+ b← c↔	--	++	++	++	+	++	-	-	a++ b← c↔	a+ b←	a+ b←
+++	-	+	--	-	+	+++	-	-	-	-	+	+	+
+++	-	c+ d↔ b←	+	-	+	+++	-	-	--	--	c+ d↔ b←	a+ b←	a+ b←
++	--	--	--	+	a++	++	+	+	--	-- c++	--	+++	+++
++	--	--	--	+	+	++	+	+	--	--	--	+++	+++
+	c+ ←	+	-	+	+	++	+	-	--	--	+	--	--
++	++ ←	+++ ←	-	+	+	++	+	+	-	-	+++ ←	--	--
+++	a++ b↔ c←	a+++ b↔ c←	ab+ c-	+	+	ab+++ c++	+	+	-	--	a+++ b↔ c←	ab- c--	--
+++	+	+++ ↔	--	+	+	++	+	+	+++	+++	++ ↔	+	--
+++	--	--	--	+	+	++	+	+	+++	+++	--	+++	+++
+++	--	--	--	-	+	+++	+	-	+++	+++	--	+++	+++
--	a+ b↔	--	--	-	++ a	+	-	+	-	--	++ a+ b↔	--	--
--	a+ b↔	--	--	-	+	+	-	+	-	++	++ a+ b↔	--	--
--	++ ←	--	--	-	a+ b+++	++	-	-	--	--	++ ←	--	--
--	+++ ←	+	--	-	+	++	-	+	+++	+++	+++ ←	--	--



$$L_{HM} = a_1 a_{SKF} \left(\frac{C}{P} \right)^p$$

Selection of bearing size

System approach and bearing reliability	50
Load ratings and life	51
Dynamic bearing loads and life.....	51
Static bearing loads.....	51
Selecting bearing size using the life equations	52
Basic rating life.....	52
SKF rating life.....	52
SKF life modification factor a_{SKF}	53
Lubrication conditions – the viscosity ratio κ	59
Consideration of EP additives.....	61
Factor η_c for contamination level.....	62
A special case – the adjustment factor a_{23}	68
Life calculation with variable operating conditions.....	70
Influence of operating temperature.....	71
Requisite rating life.....	71
Dynamic bearing loads	73
Calculation of dynamic bearing loads.....	73
Equivalent dynamic bearing load.....	74
Requisite minimum load.....	75
Selecting bearing size using the static load carrying capacity	76
Equivalent static bearing load.....	76
Required basic static load rating.....	77
Checking the static load carrying capacity.....	77
Calculation examples	78
SKF calculation tools	82
SKF Interactive Engineering Catalogue.....	82
SKF bearing beacon.....	82
Orpheus.....	82
Beast.....	83
Other programs.....	83
SKF Engineering Consultancy Services	84
Advanced computer programs.....	84
SKF life testing	85

Selection of bearing size

The bearing size to be used for an application can be initially selected on the basis of its load ratings in relation to the applied loads and the requirements regarding service life and reliability. Values for the basic dynamic load rating C and the basic static load rating C_0 are quoted in the product tables. Both dynamic and static bearing load conditions have to be independently verified. Dynamic loads should be checked using a representative spectrum of load conditions on the bearing. The load spectrum should include any peak (heavy) loads that may occur on rare occasions. Static loads are not only those that are applied with the bearing at rest or at very low rotational speeds ($n < 10$ r/min) but should include checking the static safety of heavy shock loads (very short duration loads).

System approach and bearing reliability

In the SKF life rating equation the stress resulting from the external loads is considered together with stresses originated by the surface topography, lubrication and kinematics of the rolling contact surfaces. The influence on bearing life of this combined stress system provides a better prediction of the actual performance of the bearing in a particular application.

Due to its complexity, a detailed description of the theory is beyond the scope of this catalogue. Therefore, a simplified “catalogue” approach is presented under the heading “SKF rating life”. This enables users to fully exploit bearing life

potential, to undertake controlled downsizing, and to recognize the influence of lubrication and contamination on bearing service life.

Metal fatigue of the rolling contact surfaces is generally the dominant failure mechanism in rolling bearings. Therefore, a criterion based on raceway fatigue is generally sufficient for the selection and sizing of a rolling bearing for a given application. International standards such as ISO 281 are based on metal fatigue of the rolling contact surfaces. Nevertheless, it is important to remember that the complete bearing can be viewed as a system in which the life of each component, i.e. cage, lubricant and seal (→ **fig. 1**), when present, equally contributes and in some cases dominates the effective endurance of the bearing. In theory the optimum service life is achieved when all the components reach the same life.

In other words, the calculated life will correspond to the actual service life of the bearing when the service life of other contributing mechanisms is at least as long as the calculated bearing life. Contributing mechanisms can include the cage, seal and lubricant. In practice metal fatigue is most often the dominating factor.

Fig. 1

Bearing system life

$$L_{\text{bearing}} = f(L_{\text{raceways}}, L_{\text{rolling elements}}, L_{\text{cage}}, L_{\text{lubricant}}, L_{\text{seals}})$$

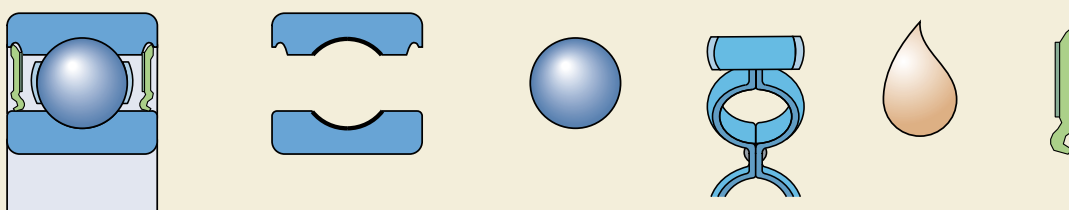

Load ratings and life

Dynamic bearing loads and life

The basic dynamic load rating C is used for calculations involving dynamically stressed bearings, i.e. a bearing that rotates under load. It expresses the bearing load that will give an ISO 281:1990 basic rating life of 1 000 000 revolutions. It is assumed that the load is constant in magnitude and direction and is radial for radial bearings and axial, centrally acting, for thrust bearings.

The basic dynamic load ratings for SKF bearings are determined in accordance with the procedures outlined in ISO 281:1990. The load ratings provided in this catalogue apply to chromium steel bearings, heat-treated to a minimum hardness of 58 HRC, and operating under normal conditions.

SKF Explorer class bearings account among others, for improvements in material and manufacturing techniques applied by SKF and apply update factors to calculate the basic dynamic load ratings according to ISO 281:1990.

The life of a rolling bearing is defined as

- the number of revolutions or
- the number of operating hours at a given speed,

which the bearing is capable of enduring before the first sign of metal fatigue (flaking, spalling) occurs on one of its rings or rolling elements.

Practical experience shows that seemingly identical bearings operating under identical conditions have different individual endurance lives. A clearer definition of the term “life” is therefore essential for the calculation of the bearing size. All information presented by SKF on dynamic load ratings is based on the life that 90 % of a sufficiently large group of apparently identical bearings can be expected to attain or exceed.

There are several other types of bearing life. One of these is “service life”, which represents the actual life of a bearing in real operating conditions before it fails. Note that individual bearing life can only be predicted statistically. Life calculations refer only to a bearing population and a given degree of reliability, i.e. 90 %, furthermore field failures are not generally caused by fatigue, but are more often caused by

contamination, wear, misalignment, corrosion, or as a result of cage, lubrication or seal failure.

Another “life” is the “specification life”. This is the life specified by an authority, for example, based on hypothetical load and speed data supplied by the same authority. It is generally a requisite L_{10} basic rating life and based on experience gained from similar applications.

Static bearing loads

The basic static load rating C_0 is used in calculations when the bearings are to

- rotate at very slow speeds ($n < 10$ r/min)
- perform very slow oscillating movements
- be stationary under load for certain extended periods.

It is also most important to check the safety factor of short duration loads, such as shock or heavy peak loads that act on a bearing, whether it is rotating (dynamically stressed) or at rest.

The basic static load rating as defined in ISO 76:1987 corresponds to a calculated contact stress at the centre of the most heavily loaded rolling element/raceway contact of

- 4 600 MPa for self-aligning ball bearings
- 4 200 MPa for all other ball bearings
- 4 000 MPa for all roller bearings.

This stress produces a total permanent deformation of the rolling element and raceway, which is approximately 0,0001 of the rolling element diameter. The loads are purely radial for radial bearings and centrally acting axial loads for thrust bearings.

Verification of the static bearing loads is performed checking the static safety factor of the application, which is defined as

$$s_0 = C_0/P_0$$

where

C_0 = basic static load rating, kN

P_0 = equivalent static bearing load, kN

s_0 = static safety factor

The maximum load that can occur on a bearing should be used in the calculation of the equivalent static bearing load. Further information about the advised values for the safety

Selection of bearing size

factor and its calculation can be found in the section “Selecting bearing size using the static load carrying capacity”, starting on **page 76**.

Selecting bearing size using the life equations

Basic rating life

The basic rating life of a bearing according to ISO 281:1990 is

$$L_{10} = \left(\frac{C}{P} \right)^p$$

If the speed is constant, it is often preferable to calculate the life expressed in operating hours, using the equation

$$L_{10h} = \frac{10^6}{60 n} L_{10}$$

where

L_{10} = basic rating life (at 90 % reliability), millions of revolutions

L_{10h} = basic rating life (at 90 % reliability), operating hours

C = basic dynamic load rating, kN

P = equivalent dynamic bearing load, kN

n = rotational speed, r/min

p = exponent of the life equation

= 3 for ball bearings

= 10/3 for roller bearings

SKF rating life

For modern high quality bearings the basic rating life can deviate significantly from the actual service life in a given application. Service life in a particular application depends on a variety of influencing factors including lubrication, the degree of contamination, misalignment, proper installation and environmental conditions.

Therefore ISO 281:1990/Amd 2:2000 contains a modified life equation to supplement the basic rating life. This life calculation makes use of a modification factor to account for the lubrication and contamination condition of the bearing and the fatigue limit of the material.

ISO 281:1990/Amd 2:2000 also makes provisions for bearing manufacturers to recommend a suitable method for calculating the life modification factor to be applied to a bearing, based on operating conditions. The SKF life modification factor a_{SKF} applies the concept of a fatigue load limit P_u analogous to that used when calculating other machine components. The values of the fatigue load limit are provided in the product tables. Furthermore, the SKF life modification factor a_{SKF} makes use of the lubrication conditions (viscosity ratio κ) and a factor η_c for the contamination level to reflect the application's operating conditions.

The equation for SKF rating life is in accordance with ISO 281:1990/Amd 2:2000

$$L_{nm} = a_1 a_{SKF} L_{10} = a_1 a_{SKF} \left(\frac{C}{P} \right)^p$$

If the speed is constant, the life can be expressed in operating hours, using the equation

$$L_{nmh} = \frac{10^6}{60 n} L_{nm}$$

where

L_{nm} = SKF rating life (at $100 - n^1$ % reliability), millions of revolutions

L_{nmh} = SKF rating life (at $100 - n^1$ % reliability), operating hours

L_{10} = basic rating life (at 90 % reliability), millions of revolutions

a_1 = life adjustment factor for reliability (→ **table 1**)

a_{SKF} = SKF life modification factor (→ **diagrams 1 to 4**)

C = basic dynamic load rating, kN

P = equivalent dynamic bearing load, kN

n = rotational speed, r/min

p = exponent of the life equation

= 3 for ball bearings

= 10/3 for roller bearings

¹⁾ The factor n represents the failure probability, i.e. the difference between the requisite reliability and 100 %

In some cases it is preferable to express bearing life in units other than millions of revolutions or hours. For example, bearing life for axle bearings used in road and rail vehicles is commonly expressed in terms of kilometres travelled. To facilitate the calculation of bearing life into different units, **table 2, page 58**, provides the conversion factors commonly used.

SKF life modification factor a_{SKF}

As mentioned, this factor represents the relationship between the fatigue load limit ratio (P_u/P), the lubrication condition (viscosity ratio κ) and the contamination level in the bearing (η_c). Values for the factor a_{SKF} can be obtained from four diagrams, depending on bearing type, as a function of $\eta_c (P_u/P)$ for SKF standard and SKF Explorer bearings and different values of the viscosity ratio κ :

Diagram 1: Radial ball bearings, **page 54**.

Diagram 2: Radial roller bearings, **page 55**.

Diagram 3: Thrust ball bearings, **page 56**.

Diagram 4: Thrust roller bearings, **page 57**.

The diagrams are drawn for typical values and safety factors of the type normally associated with fatigue load limits for other mechanical components. Considering the simplifications inherent of the SKF rating life equation, even if the operating conditions are accurately identified, it is not meaningful to use values of a_{skf} in excess of 50.

Table 1

Values for life adjustment factor a_1			
Reliability %	Failure probability n %	Rating life L_{nm}	Factor a_1
90	10	L_{10m}	1
95	5	L_{5m}	0,62
96	4	L_{4m}	0,53
97	3	L_{3m}	0,44
98	2	L_{2m}	0,33
99	1	L_{1m}	0,21

Selection of bearing size

Diagram 1

Factor a_{SKF} for radial ball bearings

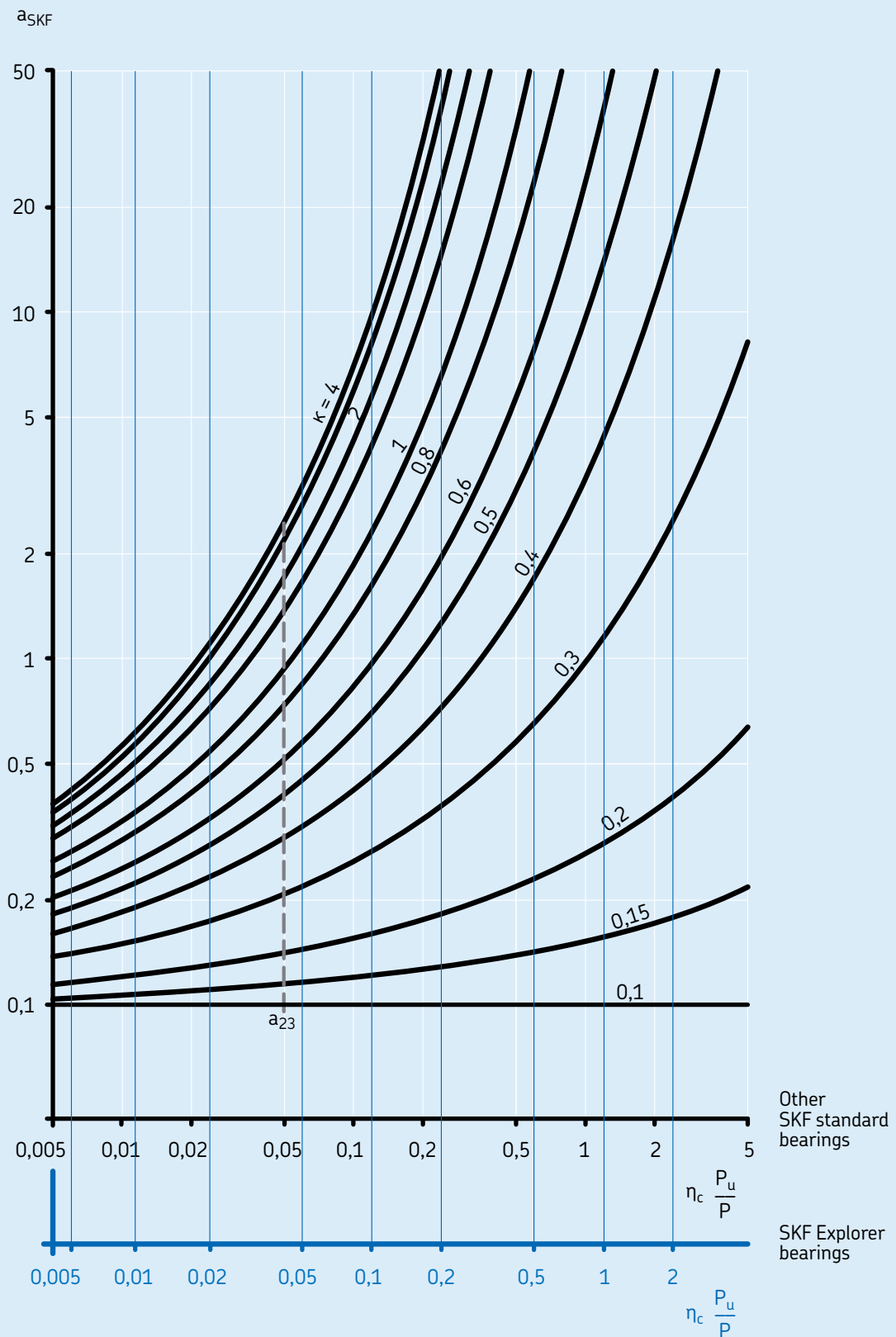

If $\kappa > 4$, use curve for $\kappa = 4$

As the value of $\eta_c (P_u/P)$ tends to zero, a_{SKF} tends to 0,1 for all values of κ

The dotted line marks the position of the old $a_{23} (\kappa)$ scale, where $a_{SKF} = a_{23}$

Factor a_{SKF} for radial roller bearings

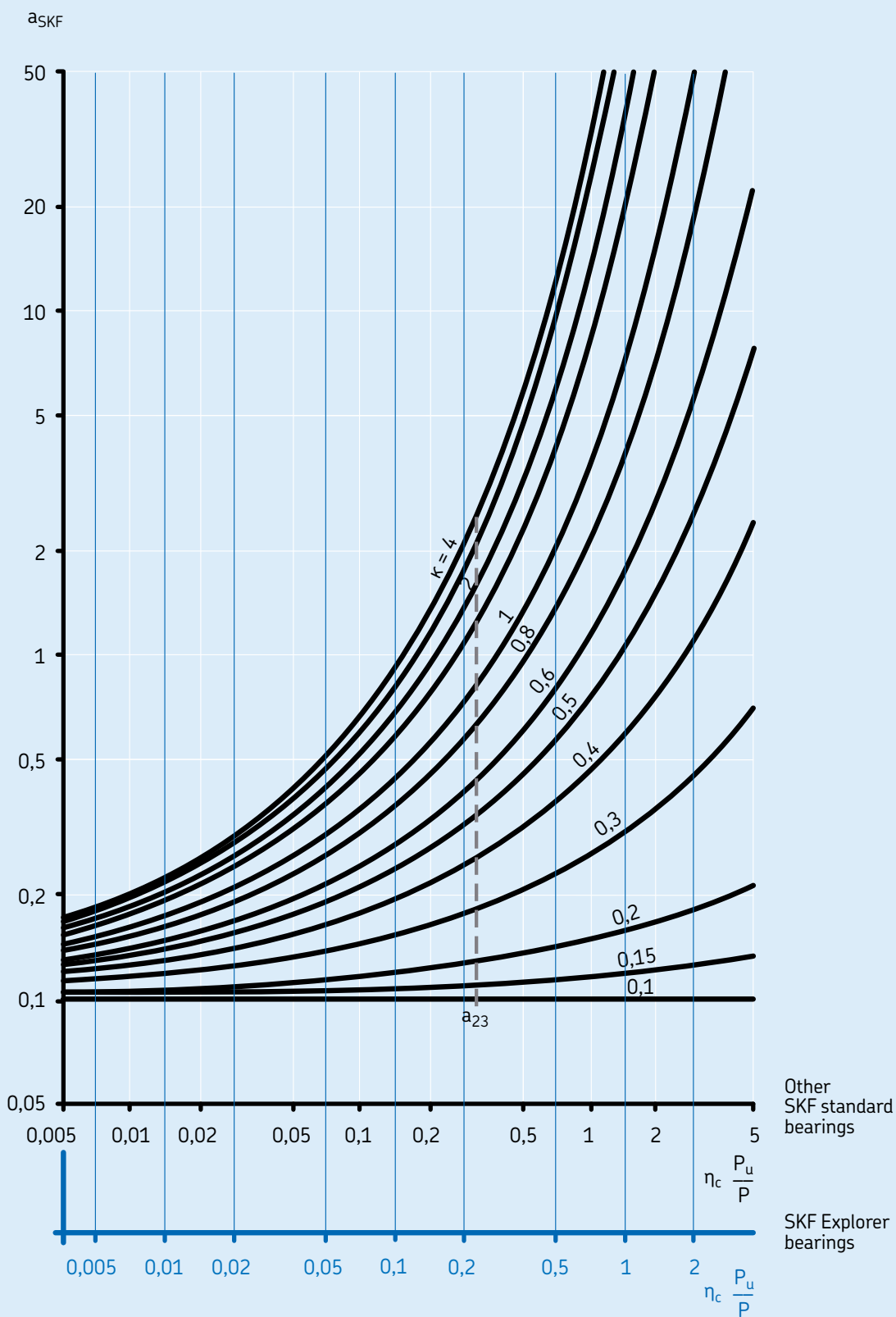

If $\kappa > 4$, use curve for $\kappa = 4$

As the value of $\eta_c (P_u/P)$ tends to zero, a_{SKF} tends to 0,1 for all values of κ

The dotted line marks the position of the old $a_{23}(\kappa)$ scale, where $a_{SKF} = a_{23}$

Factor a_{SKF} for thrust ball bearings

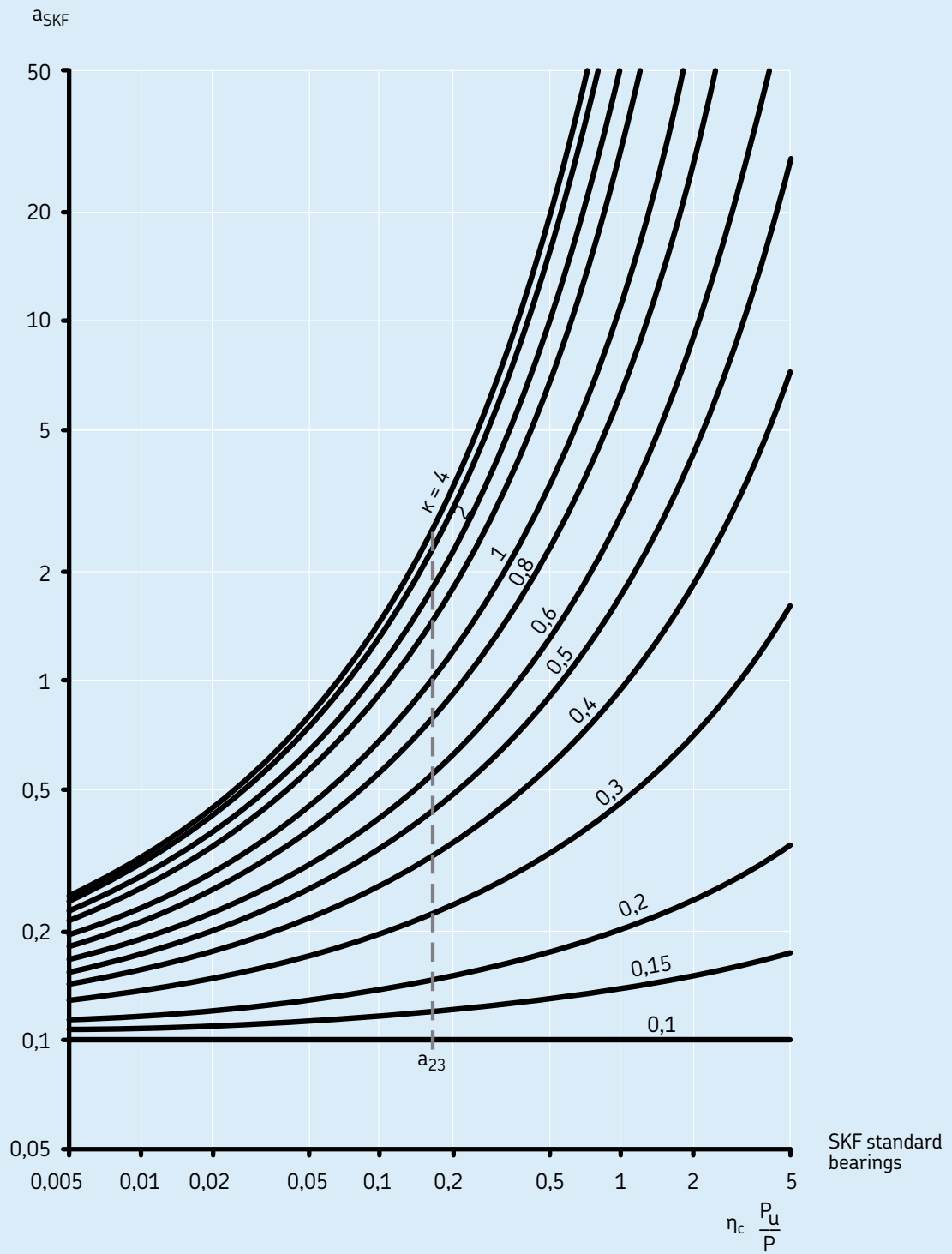

If $\kappa > 4$, use curve for $\kappa = 4$

As the value of $\eta_c (P_u/P)$ tends to zero, a_{SKF} tends to 0,1 for all values of κ

The dotted line marks the position of the old $a_{23} (\kappa)$ scale, where $a_{SKF} = a_{23}$

Factor a_{SKF} for thrust roller bearings

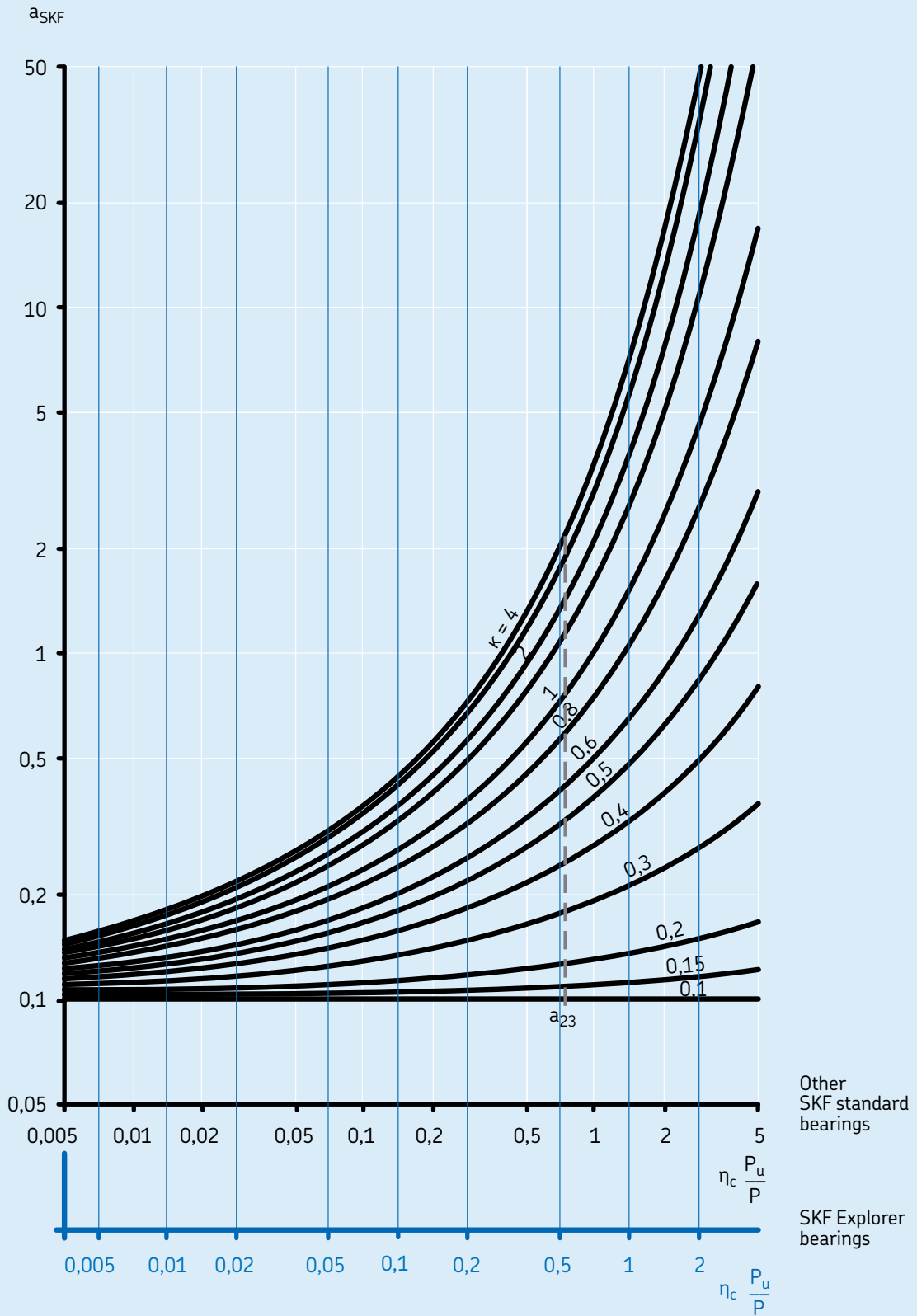

If $\kappa > 4$, use curve for $\kappa = 4$

As the value of $\eta_c (P_u/P)$ tends to zero, a_{SKF} tends to 0,1 for all values of κ

The dotted line marks the position of the old $a_{23} (\kappa)$ scale, where $a_{SKF} = a_{23}$

Selection of bearing size

Calculation of life modification factor a_{SKF}

SKF engineering programs – SKF Bearing Select, or the “SKF Interactive Engineering Catalogue”, available on CD-ROM or online at www.skf.com – can also be used to facilitate the calculation of the factor a_{SKF} . Furthermore, SKF has also developed sophisticated computer programs incorporating the SKF rating life equation directly at the rolling contact stress level, thus permitting other factors influencing bearing life, such as misalignment, shaft deflection and housing deformation to be taken into account (→ section “SKF calculation tools”, starting on page 82).

Table 2

Units conversion factors for bearing life

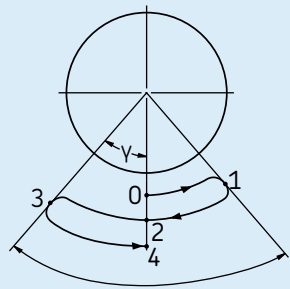

The complete oscillation = 4γ ,
i.e. from point 0 to point 4

Basic units	Conversion factor Millions of revolutions	Operating hours	Millions of kilometres travelled	Millions of oscillation cycles ¹⁾
1 million revolutions	1	$\frac{10^6}{60 n}$	$\frac{\pi D}{10^3}$	$\frac{180}{2 \gamma}$
1 operating hour	$\frac{60 n}{10^6}$	1	$\frac{60 n \pi D}{10^9}$	$\frac{180 \times 60 n}{2 \gamma 10^6}$
1 million kilometres	$\frac{10^3}{\pi D}$	$\frac{10^9}{60 n \pi D}$	1	$\frac{180 \times 10^3}{2 \gamma \pi D}$
1 million oscillation cycles ¹⁾	$\frac{2 \gamma}{180}$	$\frac{2 \gamma 10^6}{180 \times 60 n}$	$\frac{2 \gamma \pi D}{180 \times 10^3}$	1

D = vehicle wheel diameter, m

n = rotational speed, r/min

γ = oscillation amplitude (angle of max. deviation from centre position), degrees

¹⁾ Not valid for small amplitudes ($\gamma < 10$ degrees)

Lubrication conditions – the viscosity ratio κ

The effectiveness of the lubricant is primarily determined by the degree of surface separation between the rolling contact surfaces. If an adequate lubricant film is to be formed, the lubricant must have a given minimum viscosity when the application has reached its normal operating temperature. The condition of the lubricant is described by the viscosity ratio κ as the ratio of the actual viscosity ν to the rated viscosity ν_1 for adequate lubrication, both values being considered when the lubricant is at normal operating temperature (→ section “Selection of lubricating oil”, starting on **page 252**).

$$\kappa = \frac{\nu}{\nu_1}$$

where

κ = viscosity ratio

ν = actual operating viscosity of the lubricant, mm^2/s

ν_1 = rated viscosity depending on the bearing mean diameter and rotational speed, mm^2/s

In order to form an adequate lubricant film between the rolling contact surfaces, the lubricant must retain a certain minimum viscosity when the lubricant is at operating temperature. The rated viscosity ν_1 , required for adequate lubrication, can be determined from **diagram 5, page 60**, using the bearing mean diameter $d_m = 0,5(d + D)$, mm, and the rotational speed of the bearing n , r/min. This diagram has been revised taking the latest findings of tribology in rolling bearings into account.

When the operating temperature is known from experience or can otherwise be determined, the corresponding viscosity at the internationally standardized reference temperature of 40 °C can be obtained from **diagram 6, page 61**, or can be calculated. The diagram is compiled for a viscosity index of 95. **Table 3** lists the viscosity grades according to ISO 3448:1992 showing the range of viscosity for each class at 40 °C. Certain bearing types, e.g. spherical roller bearings, taper roller bearings and spherical roller thrust bearings, normally have a higher operating temperature than other bearing types, e.g. deep groove ball bearings and cylin-

drical roller bearings, under comparable operating conditions.

Table 3

Viscosity classification to ISO 3448			
Viscosity grade	Kinematic viscosity limits at 40 °C		
	mean	min	max
–	mm^2/s		
ISO VG 2	2,2	1,98	2,42
ISO VG 3	3,2	2,88	3,52
ISO VG 5	4,6	4,14	5,06
ISO VG 7	6,8	6,12	7,48
ISO VG 10	10	9,00	11,0
ISO VG 15	15	13,5	16,5
ISO VG 22	22	19,8	24,2
ISO VG 32	32	28,8	35,2
ISO VG 46	46	41,4	50,6
ISO VG 68	68	61,2	74,8
ISO VG 100	100	90,0	110
ISO VG 150	150	135	165
ISO VG 220	220	198	242
ISO VG 320	320	288	352
ISO VG 460	460	414	506
ISO VG 680	680	612	748
ISO VG 1 000	1 000	900	1 100
ISO VG 1 500	1 500	1 350	1 650

Selection of bearing size

Calculation example

A bearing having a bore diameter $d = 340$ mm and an outside diameter $D = 420$ mm is required to operate at a speed $n = 500$ r/min. Since $d_m = 0,5 (d + D)$, $d_m = 380$ mm, from **diagram 5**, the minimum rated viscosity v_1 required to provide adequate lubrication at the operating temperature is approximately 11 mm²/s. From **diagram 6**, assuming that the operating temperature of the bearing is 70 °C, it is found that a lubricant to an ISO VG 32 vis-

cosity class, with an actual viscosity v of at least 32 mm²/s at the reference temperature of 40 °C will be required.

Diagram 5

Estimation of the minimum kinematic viscosity v_1 at operating temperature

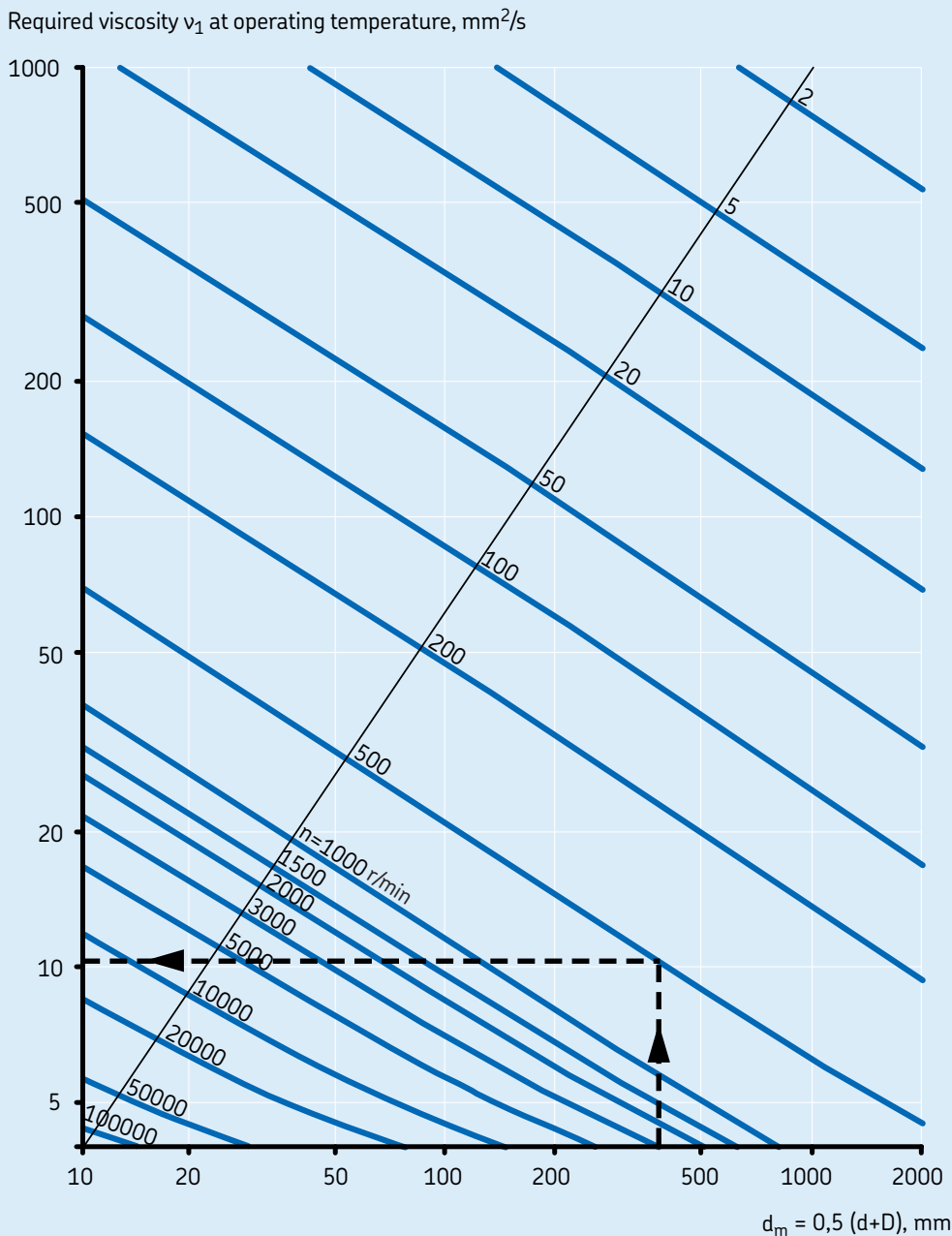

Consideration of EP additives

It is known that some EP additives in the lubricant can extend bearing service life where lubrication might otherwise be poor, e.g. when $\kappa < 1$ and if the factor for the contamination level $\eta_c \geq 0,2$, according to DIN ISO 281 Addendum 1:2003, a value of $\kappa = 1$ can be used in the calculation if a lubricant with proven effective EP additives is used. In this case the life modification factor a_{SKF} has to be limited to ≤ 3 , but not less than a_{SKF} for normal lubricants.

For the remaining range, the life modification factor a_{SKF} can be determined using the actual κ of the application. In case of severe contamination, i.e. contamination factor $\eta_c < 0,2$, the possible benefit of an EP additive has to be proved by testing. Reference should also be made to the information about EP additives presented in the section "Lubrication", starting on **page 229**.

Diagram 6

Conversion to kinematic viscosity ν at reference temperature (ISO VG classification)

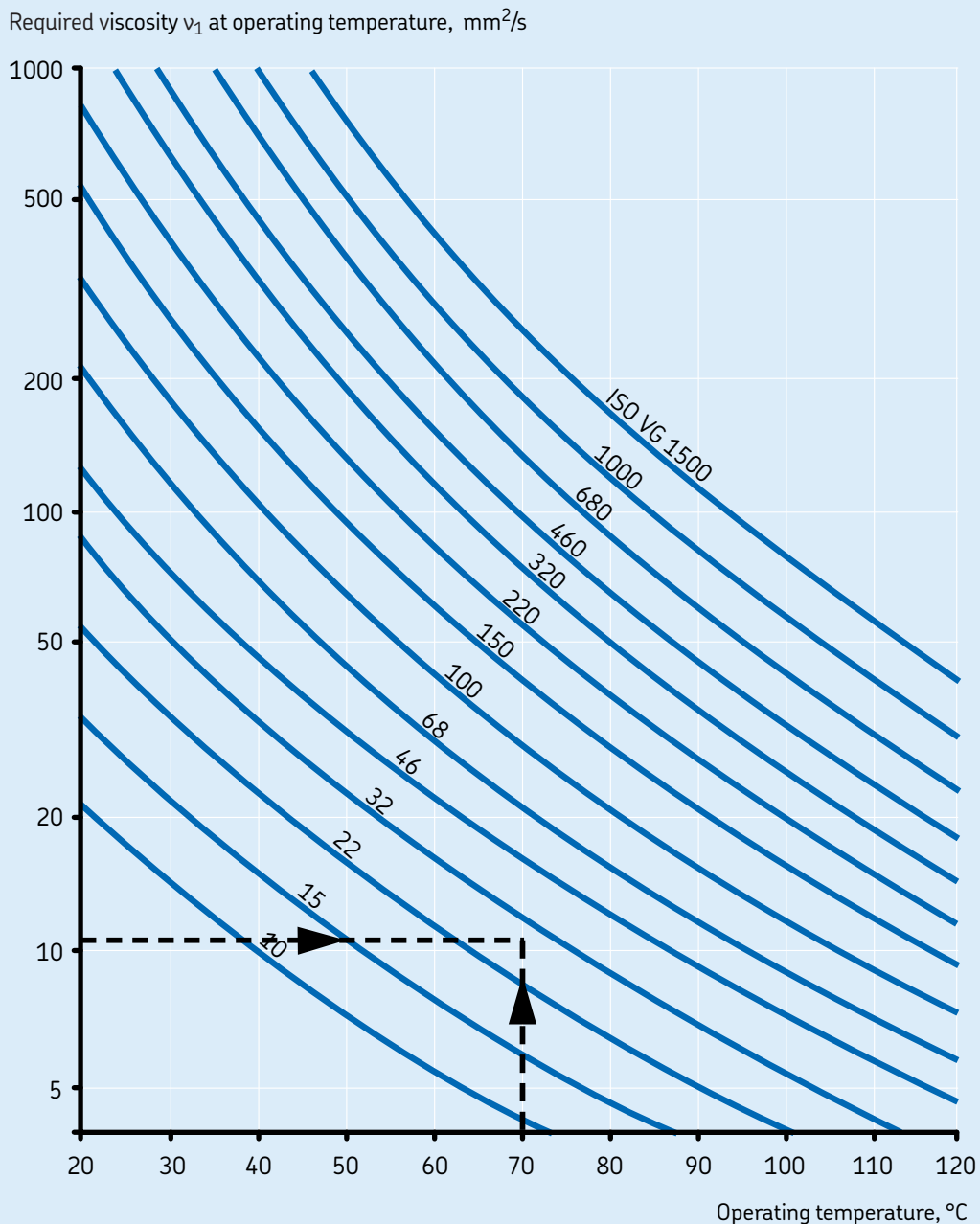

Selection of bearing size

Factor η_c for contamination level

This factor was introduced to consider the contamination level of the lubricant in the bearing life calculation. The influence of contamination on bearing fatigue depends on a number of parameters including bearing size, relative lubricant film thickness, size and distribution of solid contaminant particles, types of contamination (soft, hard etc). The influence of these parameters on bearing life is complex and many of the parameters are difficult to quantify. It is therefore not possible to allocate precise values to η_c that would have general validity. However, some guideline values are provided in **table 4**.

If the bearing is used in an application with a satisfactory record in the field and past life calculations were based on the use of the old

adjustment factor a_{23} , then a corresponding (implicit value) η_c factor can be derived to give an a_{SKF} equivalent to the a_{23} adjustment as explained in the section “A special case – the adjustment factor a_{23} ” on **page 68**.

Note that this approach will probably indicate only an approximate value of the effective factor η_c for the contamination level of the application. A second method to obtain a value for the factor η_c that is representative for an application is by quantifying the contamination level of the lubricant as input for the evaluation of the value for the factor η_c .

Table 4

Guideline values for factor η_c for different levels of contamination	Factor η_c ¹⁾ for bearings with diameter	
	$d_m < 100$ mm	$d_m \geq 100$ mm
Extreme cleanliness Particle size of the order of the lubricant film thickness Laboratory conditions	1	1
High cleanliness Oil filtered through an extremely fine filter Conditions typical of bearings greased for life and sealed	0,8 ... 0,6	0,9 ... 0,8
Normal cleanliness Oil filtered through a fine filter Conditions typical of bearings greased for life and shielded	0,6 ... 0,5	0,8 ... 0,6
Slight contamination Slight contamination of the lubricant	0,5 ... 0,3	0,6 ... 0,4
Typical contamination Conditions typical of bearings without integral seals, coarse filtering, wear particles and ingress from surroundings	0,3 ... 0,1	0,4 ... 0,2
Severe contamination Bearing environment heavily contaminated and bearing arrangement with inadequate sealing.	0,1 ... 0	0,1 ... 0
Very severe contamination Under extreme contamination, values of η_c can be outside the scale resulting in a more severe reduction of life than predicted by the equation for L_{nm}	0	0

¹⁾ The scale for η_c refers only to typical solid contaminants. Contamination by water or other fluids detrimental to bearing life is not included. In case of very heavy contamination ($\eta_c = 0$), failure will be caused by wear, the useful life of the bearing can be shorter than the rated life

ISO contamination classification and filter rating

The standard method for classifying the contamination level in a lubrication system is described in ISO 4406:1999. In this classification system the result of the solid particle counting is converted into a code using a scale number (→ **table 5** and **diagram 7, page 65**).

One method for checking the contamination level of the bearing oil is the microscope counting method. With this counting method two scale numbers, relating to the number of particles $\geq 5 \mu\text{m}$ and $\geq 15 \mu\text{m}$, are used. Another method refers to automatic particle counters, where three scale numbers are used relating to the number of particles $\geq 4 \mu\text{m}$, $\geq 6 \mu\text{m}$ and

$\geq 14 \mu\text{m}$. The classification of the contamination level comprises three scale numbers.

Typical examples of contamination level classifications for lubricating oil are -/15/12 (A) or 22/18/13 (B) as shown in **diagram 7** on **page 65**.

Example A means that the oil contains between 160 and 320 particles $\geq 5 \mu\text{m}$ and between 20 and 40 particles $\geq 15 \mu\text{m}$ per millilitre oil. Though it would be ideal if lubricating oils were continuously filtered, the viability of a filtration system would depend on the optimization between increased costs and increased service performance of the bearing.

A filter rating is an indication of filter efficiency. The efficiency of filters is defined as the filter rating or reduction factor β , which is related to a given particle size. The higher the β value, the more efficient the filter is for the specified particle size. Therefore both the β value and the specified particle size have to be considered. The filter rating β is expressed as the relationship between the number of specified particles before and after filtering. This can be calculated as follows

$$\beta_x = \frac{n_1}{n_2}$$

where

β_x = filter rating related to a specified particle size x

x = particle size, μm

n_1 = number of particles per volume unit (100 ml) larger than x, upstream the filter

n_2 = number of particles per volume unit (100 ml) larger than x, downstream the filter

Note

The filter rating β only relates to one particle size in μm , which is shown as the index e.g. β_3 , β_6 , β_{12} , etc. For example, a complete rating " $\beta_6 = 75$ " means that only 1 of 75 particles of $6 \mu\text{m}$ or larger will pass through the filter.

Determination of η_c when the contamination level is known

For oil lubrication, once the oil contamination level is known, either from a microscope count-

Table 5

ISO classification – allocation of scale number		
Number of particles per millilitre oil		Scale number
over	incl.	
2 500 000		> 28
1 300 000	2 500 000	28
640 000	1 300 000	27
320 000	640 000	26
160 000	320 000	25
80 000	160 000	24
40 000	80 000	23
20 000	40 000	22
10 000	20 000	21
5 000	10 000	20
2 500	5 000	19
1 300	2 500	18
640	1 300	17
320	640	16
160	320	15
80	160	14
40	80	13
20	40	12
10	20	11
5	10	10
2,5	5	9
1,3	2,5	8
0,64	1,3	7
0,32	0,64	6
0,16	0,32	5
0,08	0,16	4
0,04	0,08	3
0,02	0,04	2
0,01	0,02	1
0,00	0,01	0

Selection of bearing size

ing or from an automatic particle counter analysis described in ISO 4406:1999, or indirectly as a result of the filtration ratio that is applied in an oil circulation system, this information can be used to determine the factor η_c for the contamination level. Note that the factor η_c cannot be derived solely from the measure of oil contamination. It depends strongly on the lubrication condition, i.e. κ and the size of the bearing. A simplified method according to DIN ISO 281 Addendum 4:2003 is presented here to obtain the η_c factor for a given application. From the oil contamination code (or filtration ratio of the application), the contamination factor η_c is obtained, using the bearing mean diameter $d_m = 0,5 (d + D)$, mm, and the viscosity ratio κ of that bearing (→ **diagrams 8 and 9, page 66**).

Diagrams 8 and 9 provide typical values for the factor η_c for circulating oil lubrication with different degrees of oil filtration and oil contamination codes. Similar contamination factors can be applied in applications where an oil bath shows virtually no increase in the contamination particles present in the system. On the other hand, if the number of particles in an oil bath continues to increase over time, due to excessive wear or the introduction of contaminants, this must be reflected in the choice of the factor η_c used for the oil bath system as indicated in DIN ISO 281 Addendum 4:2003.

For grease lubrication η_c can also be determined in a similar way, although the contamination may be difficult to measure and is therefore defined in a simple, qualitative manner.

Diagrams 10 and 11, page 67, provide typical values for the factor η_c for grease lubrication for operating conditions of extreme cleanliness and normal cleanliness.

For other degrees of contamination for circulating oil, oil bath and grease lubrication, please refer to DIN ISO 281 Addendum 4:2003 or consult the SKF application engineering service.

An indication of the strong effect of contamination on fatigue life can be obtained from the following example. Several 6305 deep groove ball bearings with and without seals were tested in a highly contaminated environment (a gearbox with a considerable number of wear particles). No failures of the sealed bearings occurred and the tests were discontinued for practical reasons after the sealed bearings had run for periods which were at least 30 times longer than the experimental lives of the

unsealed bearings. The lives of unsealed bearings equalled 0,1 of the calculated L_{10} life, which corresponds to a factor $\eta_c = 0$ as indicated in **table 4, page 62**.

Diagrams 1 to 4, starting on **page 54**, indicate the importance of cleanliness in lubrication by the rapid reduction in the values for the factor a_{SKF} with a diminishing value of the factor η_c . Using integral seals is a very good and economical way to provide high cleanliness in the bearings.

ISO classification and examples for particle counting

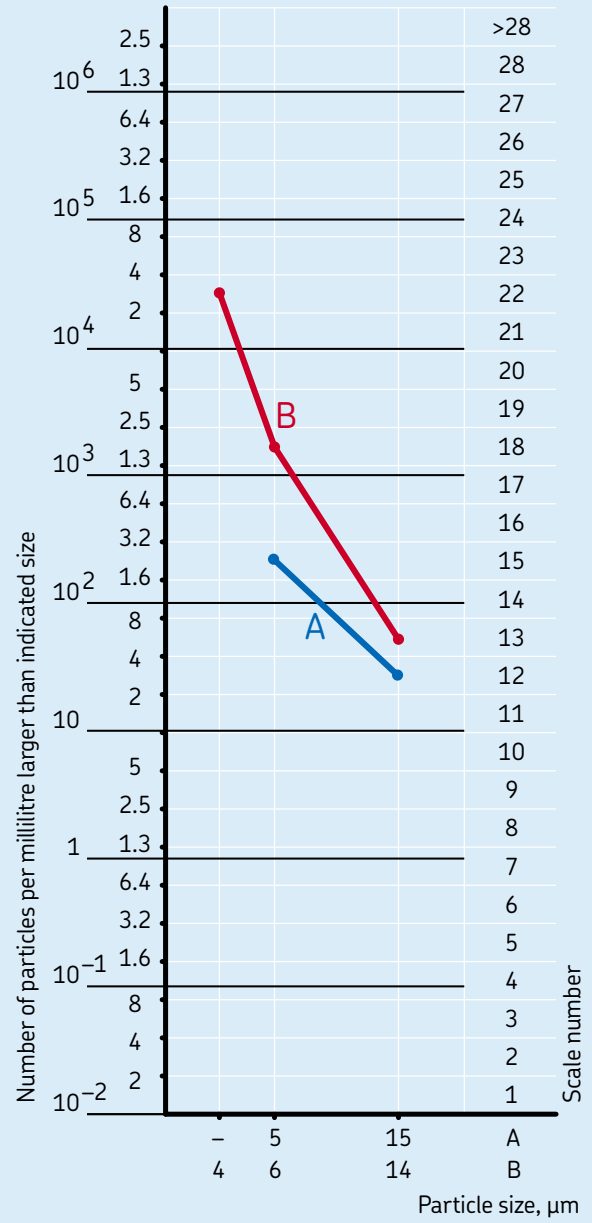

A = microscope particle counting (-/15/12)
 B = automatic particle counter (22/18/13)

Selection of bearing size

Diagram 8

Contamination factor η_c for
 – circulating oil lubrication
 – solid contamination level –/15/12 to ISO 4406:1999
 – filter rating $\beta_{12} = 200$

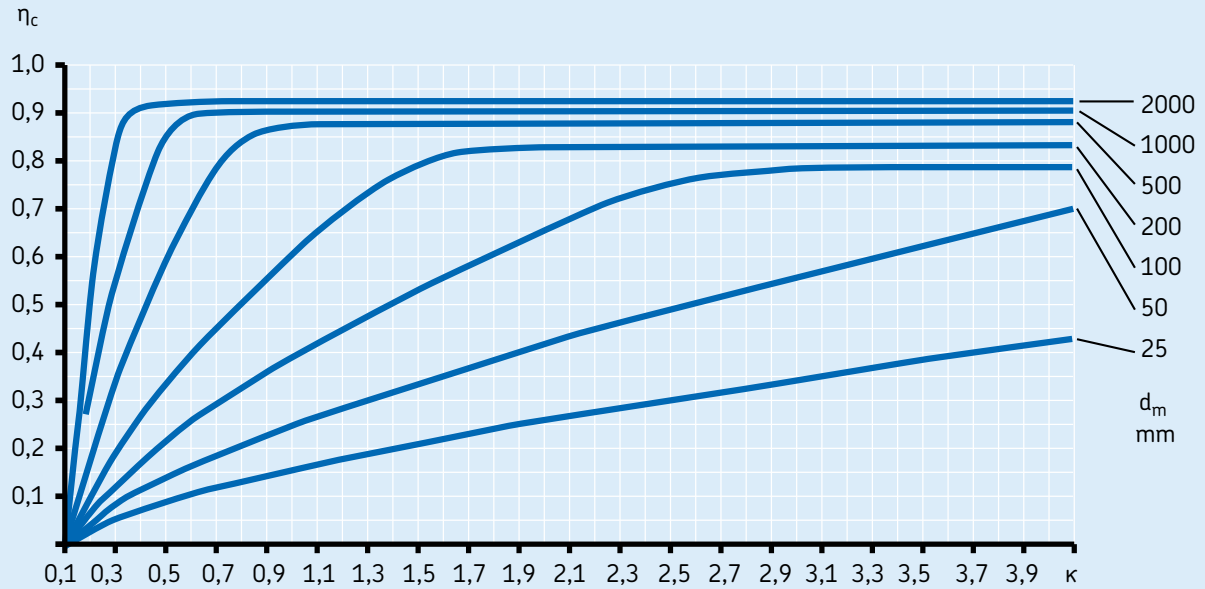

Diagram 9

Contamination factor η_c for
 – circulating oil lubrication
 – solid contamination level –/17/14 to ISO 4406:1999
 – filter rating $\beta_{25} = 75$

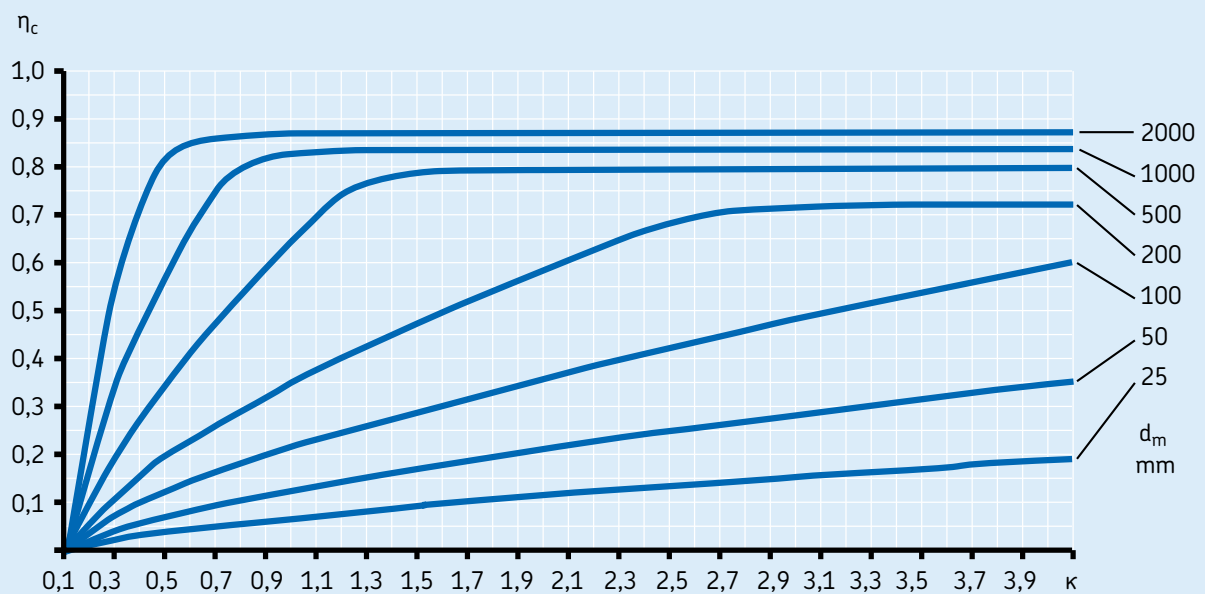

Diagram 10

Contamination factor η_c for grease lubrication, extreme cleanliness

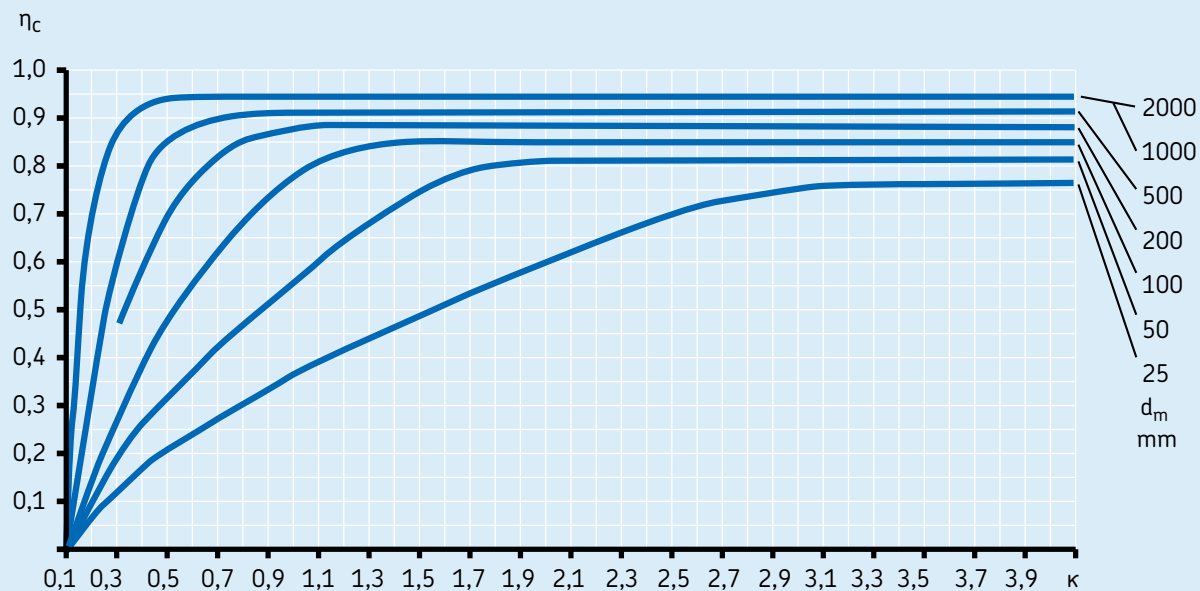
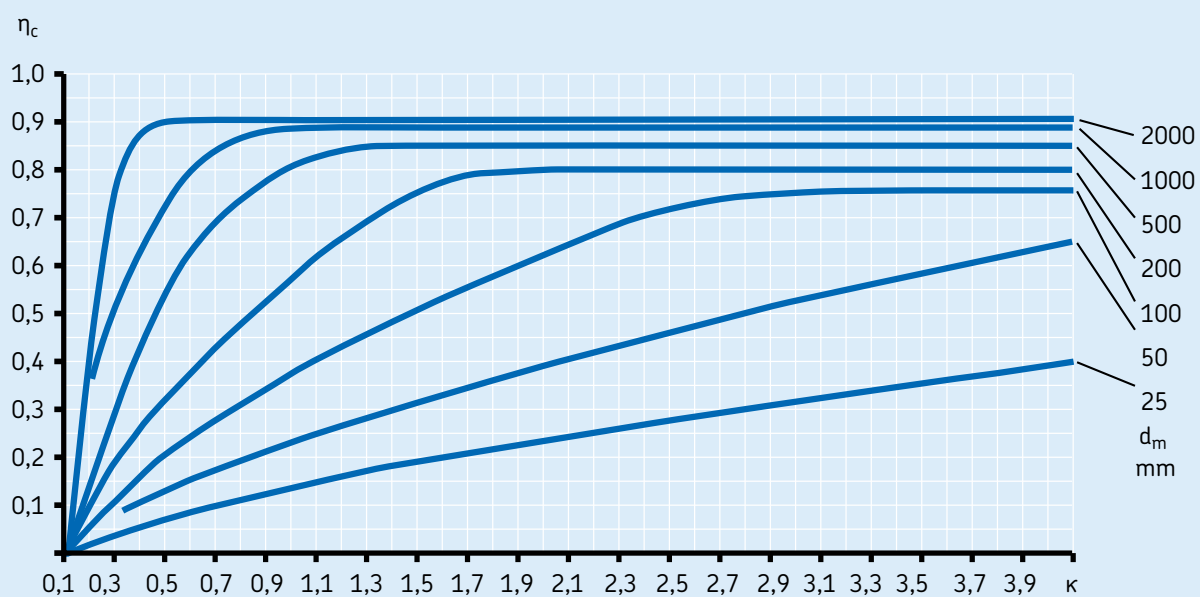

Diagram 11

Contamination factor η_c for grease lubrication, normal cleanliness



Selection of bearing size

A special case – the adjustment factor a_{23}

In previous SKF catalogues the basic rating life was adjusted using the factor a_{23} for material and lubrication. This factor was introduced by SKF in 1975.

In ISO 281:1990/Amd 2:2000 reference is made to this type of life adjustment as a special case of the more general life modification factor a_{SKF} . The a_{23} adjustment implies a specific value of the “contamination-load ratio” $[\eta_c (P_u/P)]_{23}$ used in the diagrams for the SKF life modification factor a_{SKF} . Because the factor a_{23} is only viscosity ratio κ dependent, an a_{23} scale is superimposed on the κ curves of **diagrams 1 to 4**, starting on **page 54**, for the factor a_{SKF} at the point where $\eta_c (P_u/P) = [\eta_c (P_u/P)]_{23}$. The factor η_c for contamination level thus becomes

$$\eta_c = [\eta_c (P_u/P)]_{23} / (P_u/P)$$

The location of the point where $\eta_c (P_u/P) = [\eta_c (P_u/P)]_{23}$ is marked by a dotted line and the values are listed in **table 6** for SKF standard as well as for SKF Explorer bearings. For instance, for standard radial ball bearings the corresponding η_c is

$$\eta_c = \frac{0,05}{P_u/P}$$

At that location of the “contamination-load ratio” $[\eta_c (P_u/P)]_{23} = 0,05$ in **diagram 1, page 54**, $a_{SKF} = a_{23}$ and a_{23} can be read directly from the a_{SKF} axis using the κ scale of the dotted line. The life can then be calculated with the simplified equation

$$L_{nm} = a_1 a_{23} L_{10}$$

where

L_{nm} = SKF rating life (at 100 – n % reliability), millions of revolutions

L_{10} = basic rating life (at 90 % reliability), millions of revolutions

a_1 = life factor for reliability (→ **table 1, page 53**)

a_{23} = adjustment factor for material and lubrication, when $\eta_c (P_u/P) = [\eta_c (P_u/P)]_{23}$ (→ **diagrams 1 to 4, starting on page 54**)

Table 6

Bearing type	Contamination-load ratio $[\eta_c (P_u/P)]_{23}$	
	Ratio $[\eta_c (P_u/P)]_{23}$ for SKF standard bearings	SKF Explorer bearings
Radial bearings		
Ball bearings	0,05	0,04
Roller bearings	0,32	0,23
Thrust bearings		
Ball bearings	0,16	–
Roller bearings	0,79	0,56

Using the adjustment factor a_{23} implies in practice a stress condition characterized by a value of $\eta_c (P_u/P) = [\eta_c (P_u/P)]_{23}$. If the actual $\eta_c (P_u/P)$ of the bearing is lower or higher than the $[\eta_c (P_u/P)]_{23}$ value, there will be an over or under estimation of the life performance. In other words applications with heavy loads and increased contamination or light loads and improved cleanliness are not well represented by the adjustment factor a_{23} .

For standard bearings operating at a load ratio C/P of about 5 the contamination level for a_{23} will require an η_c factor of about 0,4 to 0,5. If the actual cleanliness of the application is lower than the normal level the use of the a_{23} adjustment leads to an overestimation of the life performance of the bearing. Therefore SKF recommends using only the a_{SKF} method to improve reliability in the selection of the bearing size.

The correspondence between the adjustment factors a_{23} and a_{SKF} is useful if it is required to convert applications that were traditionally designed using the adjustment factor a_{23} to the use of the more general a_{SKF} adjustment factor. Indeed many applications that have a satisfactory record of operation, initially calculated using the adjustment factor a_{23} , can be easily converted to an equivalent factor a_{SKF} .

In practice this implies the adoption of a contamination factor η_c of the application based on the “contamination-load ratios” $[\eta_c (P_u/P)]_{23}$ listed in **table 6**. The factor η_c derived in this way represents a simple approximation or the actual factor η_c . This first estimation of the factor η_c can be further improved using oil cleanliness ratings as described in the section “Determination of η_c when the contamination level is known”, starting on **page 64**. See also calculation example 2 on **page 78**.

Selection of bearing size

Life calculation with variable operating conditions

In applications where bearing load varies over time both in magnitude and direction with changes of speed, temperature, lubrication conditions and level of contamination, the bearing life cannot be calculated directly without the need of the intermediate calculation step of an equivalent load related to the variable load conditions. Given the complexity of the system, this intermediate parameter would not be easy to determine and would not simplify the calculation.

Therefore, in the case of fluctuating operating conditions it is necessary to reduce the load spectrum or duty cycle of the application to a limited number of simpler load cases (→ **diagram 12**). In case of continuously variable load, each different load level can be accumulated and the load spectrum reduced to a histogram of constant load blocks, each characterizing a given percentage or time-fraction of the operation of the application. Note that heavy and medium loads consume bearing life at a faster rate than lighter loads. Therefore it is important to have shock and peak loads well represented in the load diagram even if the occurrence of these loads is relatively rare and limited to a few revolutions.

Within each duty interval or “bin”, the bearing load and operating conditions can be averaged to some constant value. Furthermore the number of operating hours or revolutions expected from each duty interval shows the life fraction required by that particular load condition. Thus for instance denoting with N_1 the number of revolutions required under the load condition P_1 , and with N the total life cycle of the application, then life cycle fraction $U_1 = N_1/N$ will be used by the load condition P_1 , which has a calculated life of L_{10m1} . Under variable operating conditions bearing life can be predicted using the equation

$$L_{10m} = \frac{1}{\frac{U_1}{L_{10m1}} + \frac{U_2}{L_{10m2}} + \frac{U_3}{L_{10m3}} + \dots}$$

where

- L_{10m} = SKF rating life (at 90 % reliability), millions of revolutions
- $L_{10m1}, L_{10m2}, \dots$ = fraction SKF rating lives (at 90 % reliability) under constant conditions 1, 2, ..., millions of revolutions
- U_1, U_2, \dots = life cycle fraction under the conditions 1, 2, ...
Note: $U_1 + U_2 + \dots + U_n = 1$

The use of this calculation method is very much dependent on the availability of representative load diagrams for the application. Note that such load history can also be derived from typical operating conditions or standard duty cycles required from that type of application.

Diagram 12

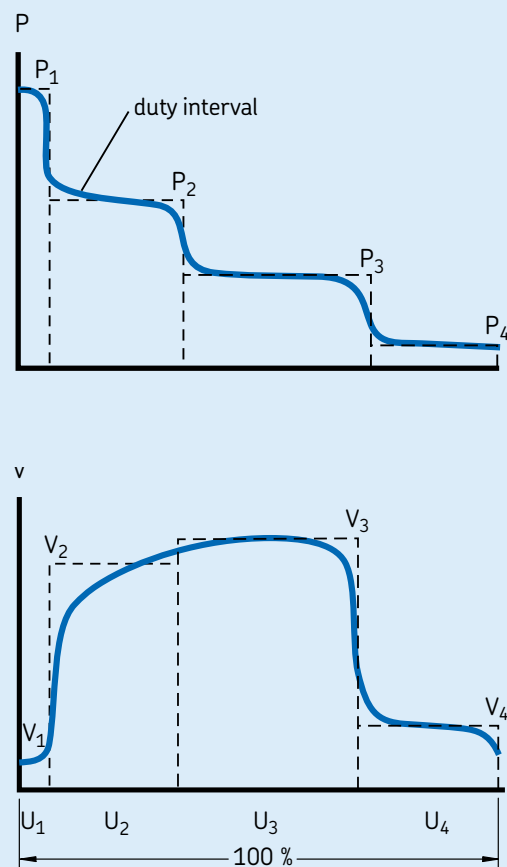

Influence of operating temperature

The dimensions of a bearing in operation change as a result of structural transformations within the material. These transformations are influenced by temperature, time and stress.

To avoid inadmissible dimensional changes in operation due to the structural transformation, bearing materials are subjected to a special heat treatment (stabilization) process (→ **table 7**).

Depending on the bearing type, standard bearings made from through-hardening and induction-hardening steels have a recommended maximum operating temperature, between 120 and 200 °C. These maximum operating temperatures are directly related to the heat treatment process. Where applicable, additional information is found in the introductory text of the product section.

If the normal operating temperatures of the application are higher than the recommended maximum temperature, a bearing with a higher stabilization class is preferred.

For applications where bearings operate continuously at elevated temperatures the dynamic load carrying capacity of the bearing may need to be adjusted.

For further information please consult the SKF application engineering service.

The satisfactory operation of bearings at elevated temperatures also depends on whether the chosen lubricant will retain its lubricating properties and whether the materials used for the seals, cages etc. are suitable (→ sections “Lubrication”, starting on **page 229**, and “Materials for rolling bearings”, starting on **page 138**).

In general, for bearings operating at high temperatures requiring higher stability class than S1, please contact the SKF application engineering service.

Requisite rating life

When determining the bearing size it is suitable to verify the calculated SKF rating life with the specification life of the application if that is available. This usually depends on the type of machine and the requirements regarding duration of service and operational reliability. In the absence of previous experience, the guideline values provided in **tables 8 and 9, page 72**, can be used.

Table 7

Dimensional stability	
Stabilization class	Stabilization up to
SN	120 °C
S0	150 °C
S1	200 °C
S2	250 °C
S3	300 °C
S4	350 °C

Selection of bearing size

Table 8

Guideline values of specification life for different types of machine	
Machine type	Specification life Operating hours
Household machines, agricultural machines, instruments, technical equipment for medical use	300 ... 3 000
Machines used for short periods or intermittently: electric hand tools, lifting tackle in workshops, construction equipment and machines	3 000 ... 8 000
Machines used for short periods or intermittently where high operational reliability is required: lifts (elevators), cranes for packaged goods or slings of drums etc.	8 000 ... 12 000
Machines for use 8 hours a day, but not always fully utilized: gear drives for general purposes, electric motors for industrial use, rotary crushers	10 000 ... 25 000
Machines for use 8 hours a day and fully utilized: machine tools, woodworking machines, machines for the engineering industry, cranes for bulk materials, ventilator fans, conveyor belts, printing equipment, separators and centrifuges	20 000 ... 30 000
Machines for continuous 24 hour use: rolling mill gear units, medium-sized electrical machinery, compressors, mine hoists, pumps, textile machinery	40 000 ... 50 000
Wind energy machinery, this includes main shaft, yaw, pitching gearbox, generator bearings	30 000 ... 100 000
Water works machinery, rotary furnaces, cable stranding machines, propulsion machinery for ocean-going vessels	60 000 ... 100 000
Large electric machines, power generation plant, mine pumps, mine ventilator fans, tunnel shaft bearings for ocean-going vessels	> 100 000

Table 9

Guideline values of specification life for axlebox bearings and units for railway vehicles	
Type of vehicle	Specification life Millions of km
Freight wagons to UIC specification based on continuously acting maximum axle load	0,8
Mass transit vehicles: suburban trains, underground carriages, light rail and tramway vehicles	1,5
Main line passenger coaches	3
Main line diesel and electric multiple units	3 ... 4
Main line diesel and electric locomotives	3 ... 5

Dynamic bearing loads

Calculation of dynamic bearing loads

The loads acting on a bearing can be calculated according to the laws of mechanics if the external forces (e.g. forces from power transmission, work forces or inertia forces) are known or can be calculated. When calculating the load components for a single bearing, the shaft is considered as a beam resting on rigid, moment-free supports for the sake of simplification. Elastic deformations in the bearing, the housing or the machine frame are not considered, nor are the moments produced in the bearing as a result of shaft deflection.

These simplifications are necessary if a bearing arrangement is to be calculated using readily available aids such as a pocket calculator. The standardized methods for calculating basic load ratings and equivalent bearing loads are based on similar assumptions.

It is possible to calculate bearing loads based on the theory of elasticity without making the above assumptions but this requires the use of complex computer programs. In these programs, the bearings, shaft and housing are considered as resilient components of a system.

External forces that arise, for example, from the inherent weight of the shaft and the components that it carries, or from the weight of a vehicle, and the other inertia forces are either known or can be calculated. However, when determining the work forces (rolling forces, cutting forces in machine tools etc.), shock forces and additional dynamic forces, e.g. as a result of unbalance, it is often necessary to rely on estimates based on experience with similar machines or bearing arrangements.

Gear trains

With gear trains, the theoretical tooth forces can be calculated from the power transmitted and the design characteristics of the gear teeth. However, there are additional dynamic forces, produced either in the gear itself or by the input drive or power take-off. Additional dynamic forces in gears result from form errors of the teeth and from unbalanced rotating components. Because of the requirements for quiet running, gears are made to high standards of accuracy and these forces are generally so small that they can be neglected when making bearing calculations.

Additional forces arising from the type and mode of operation of the machines coupled to the gear can only be determined when the operating conditions are known. Their influence on the rating lives of the bearings is considered using an "operation" factor that takes shock loads and the efficiency of the gear into account. Values of this factor for different operating conditions can usually be found in information published by the gear manufacturer.

Belt drives

For belt drives it is necessary to take the effective belt pull (circumferential force) into account, which is dependent on the transmitted torque, when calculating bearing loads. The belt pull must be multiplied by a factor, which is dependent on the type of belt, its preload, belt tension and any additional dynamic forces. Belt manufacturers usually publish values. However, should information not be available, the following values can be used for

- toothed belts = 1,1 to 1,3
- V-belts = 1,2 to 2,5
- plain belts = 1,5 to 4,5

The larger values apply when the distance between shafts is short, for heavy or shock-type duty, or where belt tension is high.

Selection of bearing size

Equivalent dynamic bearing load

If the calculated bearing load F , obtained when using the above information, is found to fulfil the requirements for the basic dynamic load rating C , i.e. the load is constant in magnitude and direction and acts radially on a radial bearing or axially and centrically on a thrust bearing, then $P = F$ and the load may be inserted directly in the life equations.

In all other cases it is first necessary to calculate the equivalent dynamic bearing load. This is defined as that hypothetical load, constant in magnitude and direction, acting radially on radial bearings or axially and centrically on a thrust bearing which, if applied, would have the same influence on bearing life as the actual loads to which the bearing is subjected (→ **fig. 2**).

Radial bearings are often subjected to simultaneously acting radial and axial loads. If the resultant load is constant in magnitude and direction, the equivalent dynamic bearing load P can be obtained from the general equation

$$P = X F_r + Y F_a$$

where

P = equivalent dynamic bearing load, kN

F_r = actual radial bearing load, kN

F_a = actual axial bearing load, kN

X = radial load factor for the bearing

Y = axial load factor for the bearing

An additional axial load only influences the equivalent dynamic load P for a single row radial

bearing if the ratio F_a/F_r exceeds a certain limiting factor e . With double row bearings even light axial loads are generally significant.

The same general equation also applies to spherical roller thrust bearings, which can accommodate both axial and radial loads. For thrust bearings which can accommodate only purely axial loads, e.g. thrust ball bearings and cylindrical roller thrust bearings, the equation can be simplified, provided the load acts centrically, to

$$P = F_a$$

All information and data required for calculating the equivalent dynamic bearing load can be found in the introductory text to each product section and in the product tables.

Fluctuating bearing load

In many cases the magnitude of the load fluctuates. The formula for life calculation with variable operating conditions should be applied (→ **page 70**).

Mean load within a duty interval

Within each loading interval the operating conditions can vary slightly from the nominal value. Assuming that the operating conditions e.g. speed and load direction are fairly constant and the magnitude of the load constantly varies between a minimum value F_{\min} and a maximum value F_{\max} (→ **diagram 13**), the mean load can be obtained from

$$F_m = \frac{F_{\min} + 2 F_{\max}}{3}$$

Rotating load

If, as illustrated in **diagram 14**, the load on the bearing consists of a load F_1 , which is constant in magnitude and direction (e.g. the weight of a rotor) and a rotating constant load F_2 (e.g. an unbalance load), the mean load can be obtained from

$$F_m = f_m (F_1 + F_2)$$

Values for the factor f_m can be obtained from **diagram 15**.

Fig. 2

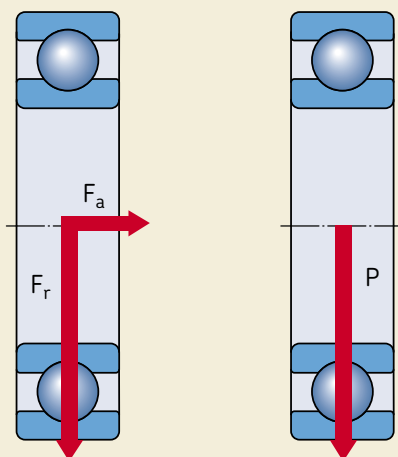
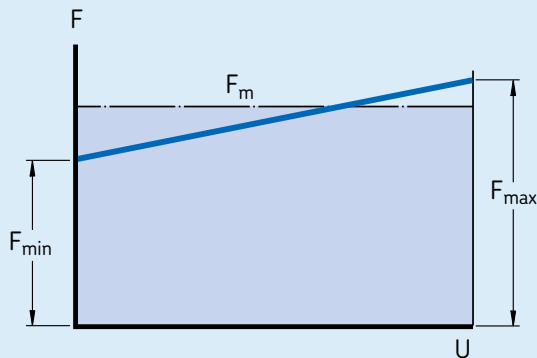

Diagram 13

Load averaging



Requisite minimum load

The correlation between load and service life is less evident at very light loads. Other failure mechanisms than fatigue are determining.

In order to provide satisfactory operation, ball and roller bearings must always be subjected to a given minimum load. A general “rule of thumb” indicates that minimum loads corresponding to 0,02 C should be imposed on roller bearings and minimum loads corresponding to 0,01 C on ball bearings. The importance of applying a minimum load increases where accelerations in the bearing are high, and where speeds are in the region of 50 % or more of the limiting speeds quoted in the product tables (→ section “Speeds and vibration”, starting on **page 107**). If minimum load requirements cannot be met, NoWear bearings could be considered (→ **page 943**).

Recommendations for calculating the requisite minimum loads for the different bearing types are provided in the text preceding each table section.

Diagram 14

Rotating load

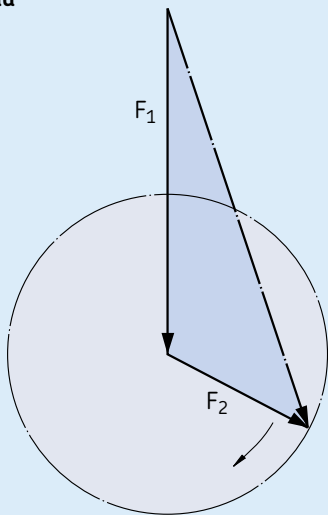
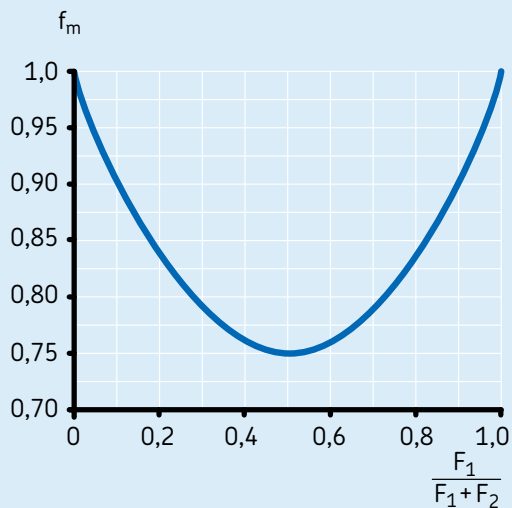

Diagram 15



Selecting bearing size using the static load carrying capacity

The bearing size should be selected on the basis of static load ratings C_0 instead of on bearing life when one of the following conditions exist:

- The bearing is stationary and is subjected to continuous or intermittent (shock) loads.
- The bearing makes slow oscillating or alignment movements under load.
- The bearing rotates under load at very slow speed ($n < 10$ r/min) and is only required to have a short life (the life equation in this case, for a given equivalent load P would give such a low requisite basic dynamic load rating C , that the bearing selected on a life basis would be seriously overloaded in service).
- The bearing rotates and, in addition to the normal operating loads, has to sustain heavy shock loads.

In all these cases, the permissible load for a bearing is determined not by material fatigue but by the amount of permanent deformation to the raceway caused by the load. Loads acting on a stationary bearing, or one which is slowly oscillating, as well as shock loads on a rotating bearing, can produce flattened areas on the rolling elements and indentations in the raceways. The indentations may be irregularly spaced around the raceway, or may be evenly spaced at positions corresponding to the spacing of the rolling elements. If the load acts for several revolutions the deformation will be evenly distributed over the whole raceway. Permanent deformations in the bearing can lead to vibration in the bearing, noisy operation and increased friction. It is also possible that the internal clearance will increase or the character of the fits may be changed.

The extent to which these changes are detrimental to bearing performance depends on the demands placed on the bearing in a particular application. It is therefore necessary to make sure that permanent deformations do not occur, or occur to a very limited extent only, by selecting a bearing with sufficiently high static load carrying capacity, if one of the following demands has to be satisfied

- high reliability
- quiet running (e.g. for electric motors)
- vibration-free operation (e.g. for machine tools)
- constant bearing frictional moment (e.g. for measuring apparatus and test equipment)
- low starting friction under load (e.g. for cranes).

Equivalent static bearing load

Static loads comprising radial and axial components must be converted into an equivalent static bearing load. This is defined as that hypothetical load (radial for radial bearings and axial for thrust bearings) which, if applied, would cause the same maximum rolling element load in the bearing as the actual loads to which the bearing is subjected. It is obtained from the general equation

$$P_0 = X_0 F_r + Y_0 F_a$$

where

P_0 = equivalent static bearing load, kN

F_r = actual radial bearing load (see below), kN

F_a = actual axial bearing load (see below), kN

X_0 = radial load factor for the bearing

Y_0 = axial load factor for the bearing

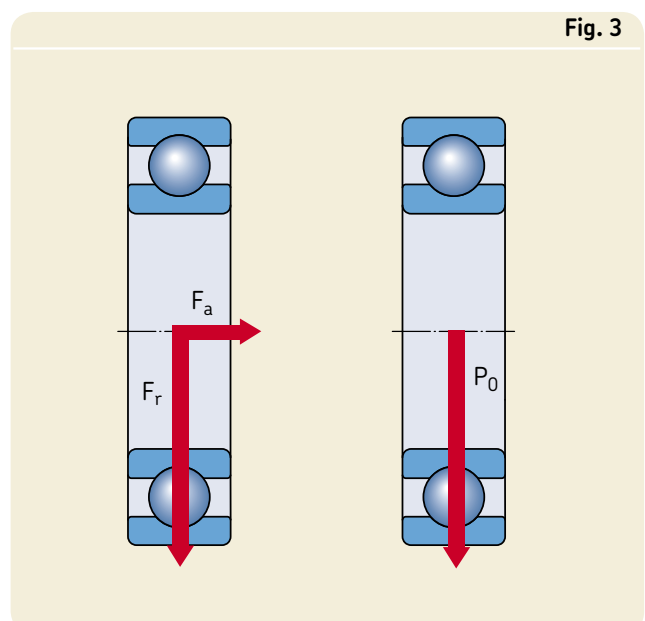

Note

When calculating P_0 , the maximum load that can occur should be used and its radial and axial components (→ **fig. 3**) inserted in the equation above. If a static load acts in different directions on a bearing, the magnitude of these components will change. In these cases, the components of the load giving the largest value of the equivalent static bearing load P_0 should be used.

Information and data necessary for the calculation of the equivalent static bearing load can be found in the introductory text to each product section and in the tables.

Required basic static load rating

When determining bearing size based on the static load carrying capacity a given safety factor s_0 , which represents the relationship between the basic static load rating C_0 and the equivalent static bearing load P_0 , is used to calculate the requisite basic static load rating.

The required basic static load rating C_0 can be determined from

$$C_0 = s_0 P_0$$

where

C_0 = basic static load rating, kN

P_0 = equivalent static bearing load, kN

s_0 = static safety factor

Guideline values based on experience are provided in **table 10** for the static safety factor s_0 for ball and roller bearings for various applications requiring smooth running. At elevated temperatures the static load carrying capacity is reduced. Further information will be supplied on request.

Checking the static load carrying capacity

For dynamically loaded bearings it is advisable, where the equivalent static bearing load P_0 is known, to check that the static load carrying capacity is adequate using

$$s_0 = C_0/P_0$$

If the s_0 value obtained is less than the recommended guideline value (→ **table 10**), a bearing with a higher basic static load rating should be selected.

Table 10

Type of operation	Rotating bearing						Non-rotating bearing	
	Requirements regarding quiet running							
	unimportant		normal		high		Ball bearings	Roller bearings
	Ball bearings	Roller bearings	Ball bearings	Roller bearings	Ball bearings	Roller bearings	Ball bearings	Roller bearings
Smooth, vibration-free	0,5	1	1	1,5	2	3	0,4	0,8
Normal	0,5	1	1	1,5	2	3,5	0,5	1
Pronounced shock loads ¹⁾	≥ 1,5	≥ 2,5	≥ 1,5	≥ 3	≥ 2	≥ 4	≥ 1	≥ 2

For spherical roller thrust bearings it is advisable to use $s_0 \geq 4$

¹⁾ Where the magnitude of the shock load is not known, values of s_0 at least as large as those quoted above should be used. If the magnitude of the shock loads is exactly known, smaller values of s_0 can be applied

Calculation examples

Example 1

An SKF Explorer 6309 deep groove ball bearing is to operate at 3 000 r/min under a constant radial load $F_r = 10$ kN. Oil lubrication is to be used, the oil having an actual kinematic viscosity $\nu = 20$ mm²/s at normal operating temperature. The desired reliability is 90 % and it is assumed that the operating conditions are very clean. What will be the basic and SKF rating lives?

a) The basic rating life for 90 % reliability is

$$L_{10} = \left(\frac{C}{P}\right)^3$$

From the product table for bearing 6309, $C = 55,3$ kN. Since the load is purely radial, $P = F_r = 10$ kN (→ “Equivalent dynamic bearing load” on **page 74**).

$$L_{10} = (55,3/10)^3$$

= 169 millions of revolutions

or in operating hours, using

$$L_{10h} = \frac{10^6}{60 n} L_{10}$$

$$L_{10h} = 1\,000\,000 / (60 \times 3\,000) \times 169$$

= 940 operating hours

b) The SKF rating life for 90 % reliability is

$$L_{10m} = a_1 a_{SKF} L_{10}$$

- As a reliability of 90 % is required, the L_{10m} life is to be calculated and $a_1 = 1$ (→ **table 1, page 53**).
- From the product table for bearing 6309, $d_m = 0,5 (d + D) = 0,5 (45 + 100) = 72,5$ mm
- From **diagram 5, page 60**, the rated oil viscosity at operating temperature for a speed of 3 000 r/min, $\nu_1 = 8,15$ mm²/s. Therefore $\kappa = \nu/\nu_1 = 20/8,15 = 2,45$

- Again from the product table $P_u = 1,34$ kN and $P_u/P = 1,34/10 = 0,134$. As the conditions are very clean, $\eta_c = 0,8$ and $\eta_c P_u/P = 0,107$. With $\kappa = 2,45$ and using the SKF Explorer scale of **diagram 1, page 54**, the value of $a_{SKF} = 8$ is obtained. Then according to the SKF rating life equation

$$L_{10m} = 1 \times 8 \times 169$$

= 1 352 millions of revolutions

or in operating hours using

$$L_{10mh} = \frac{10^6}{60 n} L_{10m}$$

$$L_{10mh} = 1\,000\,000 / (60 \times 3\,000) \times 1\,352$$

= 7 512 operating hours

Example 2

The SKF Explorer 6309 deep groove ball bearing in example 1 belongs to an existing application that was calculated some years ago using the adjustment factor a_{23} . This application fully satisfied the requirements. It is requested to recalculate the life of this bearing in terms of the adjustment factor a_{23} and also of the factor a_{SKF} (based on the field experience of this application), i.e. $a_{SKF} = a_{23}$. Finally it is requested to obtain the factor η_c for the contamination level in the application under the condition $a_{SKF} = a_{23}$.

- With $\kappa = 2,45$, using the a_{23} scale superimposed on the κ curves for the SKF life modification factor a_{SKF} of **diagram 1 on page 54**, factor $a_{23} \approx 1,8$ which can be read on the a_{SKF} axis. Taking into account that this application fully satisfied the requirement, it can be safely assumed that $a_{SKF} = a_{23}$, thus

$$L_{10mh} = a_{23} L_{10h} = a_{SKF} L_{10h}$$

and

$$L_{10mh} = 1,8 \times 940 = 1\,690 \text{ operating hours}$$

- The factor η_c corresponding to this life adjustment is according to **table 6** on **page 68** and for an SKF Explorer 6309 bearing with $P_u/P = 0,134$

$$\eta_c = [\eta_c (P_u/P)]_{23} / (P_u/P) = 0,04/0,134 = 0,3$$

Example 3

An existing application has to be reviewed. An SKF Explorer 6309-2RS1 deep groove ball bearing with integral seals and grease filling, is working under the same conditions as described in example 2 ($\kappa = 2,45$). The contamination conditions of this application have to be checked, to determine if it is possible to reduce the costs for a minimum requisite life of 3 000 hours of operation.

- Considering grease lubrication and integral seals the level of contamination can be characterized as high cleanliness and from **table 4** on **page 62**, $\eta_c = 0,8$. With $P_u/P = 0,134$, $\eta_c (P_u/P) = 0,107$, using the SKF Explorer scale in **diagram 1** on **page 54** and $\kappa = 2,45$, $a_{SKF} = 8$.

$$L_{10mh} = 8 \times 940 = 7\,520 \text{ operating hours}$$

- For a lower cost version – if possible – of the same bearing arrangement an SKF Explorer 6309-2Z bearing with shields is selected. The contamination level can be characterized as normal cleanliness, then from **table 4** on **page 62**, $\eta_c = 0,5$. With $P_u/P = 0,134$, $\eta_c (P_u/P) = 0,067$, using the SKF Explorer scale in **diagram 1** on **page 54** and $\kappa = 2,45$, $a_{SKF} \approx 3,5$.

$$L_{10mh} = 3,5 \times 940 = 3\,290 \text{ operating hours}$$

Conclusion: If possible, this application would be able to take advantage of a more cost effective solution by replacing the sealed bearing with a shielded one.

Note that the use of the rating life based on the a_{23} adjustment factor would not enable this design evaluation. Furthermore it would not be possible to reach the requisite life (\rightarrow example 2, calculated life with the a_{23} adjustment factor would only give 1 690 operating hours).

Example 4

The SKF Explorer 6309 deep groove ball bearing used in example 1 belongs to an existing application that was calculated some years ago using the adjustment factor a_{23} . From the field, there have been complaints of bearing failures. It is required to evaluate the design of this bearing application to determine suitable steps to increase its reliability.

- First the life is determined based on the a_{23} factor. With $\kappa = 2,45$, using the a_{23} scale superimposed on the κ curves for the SKF life modification factor a_{SKF} in **diagram 1** on **page 54**, $a_{23} \approx 1,8$ which can be read on the a_{SKF} axis.

$$L_{10mh} = a_{23} \times L_{10h} = 1,8 \times 940$$

$$= 1\,690 \text{ operating hours}$$

- The factor η_c corresponding to this life adjustment factor a_{23} is according to **table 6** on **page 68** and for $P_u/P = 0,134$

$$\eta_c = [\eta_c (P_u/P)]_{23} / (P_u/P) = 0,04/0,134 = 0,3$$

- A microscope counting of an oil sample taken from the application indicated a contamination classification of $-/17/14$ according to ISO 4406:1999. The contamination consisted mainly of wear particles originated in the system. This can be characterized as “typical contamination”, thus from **table 4** on **page 62** and also from **diagram 9** on **page 66**, $\eta_c = 0,2$. With $P_u/P = 0,134$, $\eta_c (P_u/P) = 0,0268$, using the SKF Explorer scale in **diagram 1** on **page 54** and $\kappa = 2,45$, $a_{SKF} \approx 1,2$.

$$L_{10mh} = 1,2 \times 940 = 1\,130 \text{ operating hours}$$

- By using an SKF Explorer 6309-2RS1 bearing with integral contact seals, the level of contamination can be reduced to the level of “high cleanliness”. Then from **table 4** on **page 62**, $\eta_c = 0,8$. With $P_u/P = 0,134$, $\eta_c (P_u/P) = 0,107$, using the SKF Explorer scale in **diagram 1** on **page 54** and $\kappa = 2,45$, $a_{SKF} = 8$.

$$L_{10mh} = 8 \times 940 = 7\,520 \text{ operating hours}$$

Selection of bearing size

Conclusion: This application has a level of contamination that is more severe than the factor $\eta_c = 0,3$ for the contamination level implicit when using the factor a_{23} , while the real operating conditions, which are typical for contaminated industrial transmissions, call for a factor $\eta_c = 0,2$ when using the factor a_{SKF} .

This may explain the cause of the failures that were experienced with this application. The use of an SKF Explorer 6309-2RS1 bearing with integral contact seals will increase the reliability considerably and overcome this problem.

Example 5

The duty cycle of a sealed SKF Explorer spherical roller bearing 24026-2CS2/VT143 used in heavy transportation equipment of a steel plant has the operating conditions listed in the table below.

The static load of this application is determined reasonably accurately, taking into account the inertia of the load during the loading operation and the occurrence of shock loads for accidental load dropping.

It is required to verify the dynamic and static load conditions of this application, assuming a required L_{10mh} operating life of 60 000 hours and a minimum static safety factor of 1,5.

- From the product table and introductory text:

Load ratings:

$$C = 540 \text{ kN}; C_0 = 815 \text{ kN}; P_u = 81,5 \text{ kN}$$

Dimensions:

$$d = 130 \text{ mm}; D = 200 \text{ mm},$$

$$\text{thus } d_m = 0,5 (130 + 200) = 165 \text{ mm}$$

Grease filling:

Extreme pressure grease with a lithium thickener and mineral base oil, of NLGI consistency class 2, for a temperature range of -20 to $+110$ °C and a base oil viscosity at 40 and 100 °C of 200 and 16 mm^2/s , respectively.

- The following calculations are made or values determined:

- v_1 = rated viscosity, mm^2/s (→ **diagram 5** on **page 60**) – input: d_m and speed
- v = actual operating viscosity, mm^2/s (→ **diagram 6** on **page 61**) – input: lubricant viscosity at 40 °C and operating temperature
- κ = viscosity ratio – calculated (v/v_1)
- η_c = factor for contamination level (→ **table 4** on **page 62**) – “High cleanliness”, sealed bearing: $\eta_c = 0,8$

Example 5/1

Operating conditions					
Duty interval	Equivalent dynamic load	Time fraction	Speed	Temperature	Equivalent static load
–	kN	–	r/min	°C	kN
1	200	0,05	50	50	500
2	125	0,40	300	65	500
3	75	0,45	400	65	500
4	50	0,10	200	60	500

5. L_{10h} = basic rating life according to the equation listed on **page 52** – input: C, P and n
6. a_{SKF} = from **diagram 2** on **page 55** – input: SKF Explorer bearing, η_c , P_u , P and κ
7. $L_{10mh1,2, \dots}$ = SKF rating life according to the equation listed on **page 53** – input a_{SKF} and $L_{10h1,2, \dots}$
8. L_{10mh} = SKF rating life according to the equation listed on **page 70** – input L_{10mh1} , $L_{10mh2, \dots}$ and U_1, U_2, \dots

The SKF rating life of 84 300 hours exceeds the required service life, thus the dynamic load conditions of the bearing are verified.

Finally the static safety factor of this application is examined.

$$s_0 = \frac{C_0}{P_0} = \frac{815}{500} = 1,63$$

$$s_0 = 1,63 > s_{0 \text{ req}}$$

The above shows that the static safety of this application is verified. As the static load is determined accurately, the relatively small margin between the calculated and recommended static safety is of no concern.

Example 5/2

Calculation values										
Duty interval	Equivalent dynamic load	Rated viscosity v_1	Operating viscosity v	$\kappa^1)$	η_c	Basic rating life L_{10h}	a_{SKF}	SKF rating life L_{10mh}	Time fraction U	Resulting SKF rating life L_{10mh}
–	kN	mm ² /s	mm ² /s	–	–	h	–	h	–	h
1	200	120	120	1	0,8	9 136	1,2	11 050	0,05	84 300
2	125	25	60	2,3	0,8	7 295	7,8	57 260	0,40	
3	75	20	60	3	0,8	30 030	43	1 318 000	0,45	
4	50	36	75	2	0,8	232 040	50	11 600 000	0,10	

¹⁾ Grease with EP additives

SKF calculation tools

SKF possesses one of the most comprehensive and powerful sets of modelling and simulation packages in the bearing industry. They range from easy-to-use tools based on SKF General Catalogue formulae to the most sophisticated calculation and simulation systems, running on parallel computers.

The company's philosophy is to develop a range of programs to satisfy a number of customer requirements; from fairly simple design checks, through moderately complex investigations, to the most advanced simulations for bearing and machine design. Wherever possible, these programs are available for in-the-field use on customers' or SKF engineers' laptops, desk top PCs or workstations. Moreover, particular care is taken to provide integration and interoperability of the different systems with each other.

SKF Interactive Engineering Catalogue

The SKF Interactive Engineering Catalogue (IEC) is an easy-to-use tool for bearing selection and calculation. Bearing searches are available based on designation or dimensions, and simple bearing arrangements can be evaluated as well. The equations used are in line with this SKF General Catalogue.

It also enables the generation of CAD bearing drawings that can be imported into customer application drawings developed with the major CAD commercial packages.

The SKF Interactive Engineering Catalogue also contains, in addition to the complete range of rolling bearings, catalogues covering bearing units, bearing housings, plain bearings and seals.

The SKF Interactive Engineering Catalogue is published on CD-ROM or on the Internet at www.skf.com.

SKF bearing beacon

SKF bearing beacon is the new mainstream bearing application program used by SKF engineers to find the best solution for customers' bearing arrangements. The program is the successor of BEACON and its technology enables the modelling in a 3D graphic environment of flexible systems incorporating customer com-



ponents. SKF bearing beacon combines the ability to model generic mechanical systems (using also shafts, gears, housings etc.) with a precise bearing model for an in-depth analysis of the system behaviour in a virtual environment. It also performs bearing rolling fatigue evaluation using the SKF rating life in particular. SKF bearing beacon is the result of several years of specific research and development within SKF.

Orpheus

The numerical tool Orpheus enables studying and optimizing the dynamic behaviour of noise and vibration critical bearing applications (e.g. electric motors, gearboxes). It can be used to solve the complete non-linear equations of motion of a set of bearings and their surrounding components, including gears, shafts and housings.

It can provide profound understanding of and advice on the dynamic behaviour of an application, including the bearings, accounting for form deviations (waviness) and mounting errors (misalignment). This enables SKF engineers to determine the most suitable bearing type and size as well as the corresponding mounting and preload conditions for a given application.

Beast

Beast is a simulation program that enables SKF engineers to simulate the detailed dynamics inside a bearing. It can be seen as a virtual test rig performing detailed studies of forces, moments etc. inside a bearing under virtually any load condition. This enables the “testing” of new concepts and designs in a shorter time and with more information gained compared with traditional physical testing.

Other programs

In addition to the above-mentioned programs, SKF has developed dedicated computer programs that enable SKF scientists to provide customers with bearings having an optimized bearing surface finish to extend bearing life under severe operating conditions. These programs can calculate the lubricant film thickness in elasto-hydrodynamically lubricated contacts. In addition, the local film thickness resulting from the deformation of the three dimensional surface topography inside such contacts is calculated in detail and the consequent reduction of bearing fatigue life.

In order to complete the necessary capabilities for their tasks, SKF engineers use commercial packages to perform e.g. finite element or generic system dynamics analyses. These tools are integrated with the SKF proprietary systems enabling a faster and more robust connection with customer data and models.

SKF Engineering Consultancy Services

The basic information required to calculate and design a bearing arrangement can be found in this catalogue. But there are applications where it is desirable to predict the expected bearing life as accurately as possible, either because sufficient experience with similar bearing arrangements is lacking, or because economy and/or operational reliability are of extreme importance. In such cases, for example, it is advisable to consult the “SKF Engineering Consultancy Services”. They provide calculations and simulations utilizing high-tech computer programs, in combination with an almost one hundred year global experience in the field of rotating machine components.

They can provide support with the complete SKF application know-how. The SKF application specialists can

- analyse the technical problems
- suggest the appropriate system solution
- select the appropriate lubrication and an optimized maintenance practice.

SKF Engineering Consultancy Services provides a new approach to services concerning machines and installations for OEM and end-users. Some of these service benefits are:

- Faster development processes and reduced time to market.
- Reduced implementation costs by virtual testing before production start.
- Improved bearing arrangement by lowering noise and vibration levels.
- Higher power density by upgrading.
- Longer service life by improving lubrication or sealing.

Advanced computer programs

Within the SKF Engineering Consultancy Services there are highly advanced computer programs which can be used for

- analytical modelling of complete bearing arrangements, consisting of shaft, housing, gears, couplings, etc.

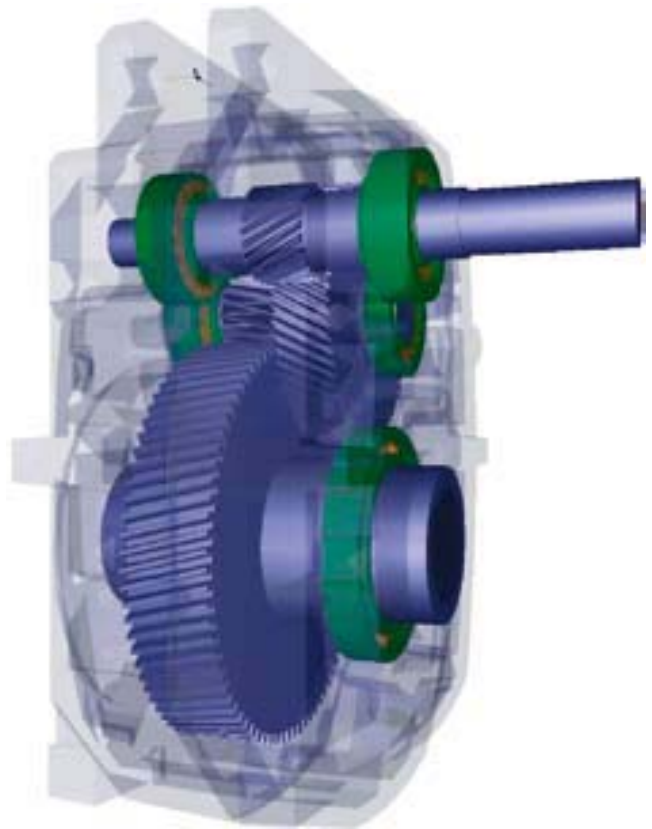

- static analysis, i.e. determination of elastic deformations and stresses in components of mechanical systems
- dynamic analysis, i.e. determination of the vibration behaviour of systems under working conditions (“virtual testing”)
- visual and animated presentation of structural and component deflection
- optimizing system costs, service life, vibration and noise levels.

The high-tech computer programs used within the SKF Engineering Consultancy Services as standard for calculation and simulations are briefly described in the section “SKF calculation tools” on **page 82**.

For further information about the activities of the SKF Engineering Consultancy Services please contact the nearest SKF company.

SKF life testing

SKF endurance testing activities are concentrated at the SKF Engineering Research Centre in the Netherlands. The test facilities there are unique in the bearing industry as regards sophistication and number of test rigs. The centre also supports work carried out at the research facilities of the major SKF manufacturing companies.

SKF undertakes life testing, mainly to be able to continuously improve its products. It is essential to understand and to formulate the fundamental physical laws governing bearing behaviour as a function of internal and external variables. Such variables may represent material properties, internal bearing geometry and conformity, cage design, misalignment, temperature and other operating conditions. However, many influencing factors are not of static but rather of dynamic nature. Examples are the topography of working contact surfaces, the material structure, the internal geometry and the lubricant properties, which continuously undergo change during the bearing operation.

SKF also undertakes life testing to

- verify the performance commitments made in product catalogues
- audit the quality of the SKF standard bearing production
- research the influences of lubricants and lubricating conditions on bearing life
- support the development of theories for rolling contact fatigue
- compare with competitive products.

The powerful and firmly controlled life testing procedure combined with post-test investigations with modern and highly sophisticated equipment makes it possible to investigate the factors and their interactions in a systematic way.

High performance SKF Explorer bearings are an example of the implementation of the optimized influencing factors on the basis of analytical simulation models and experimental verification at component and full bearing level.

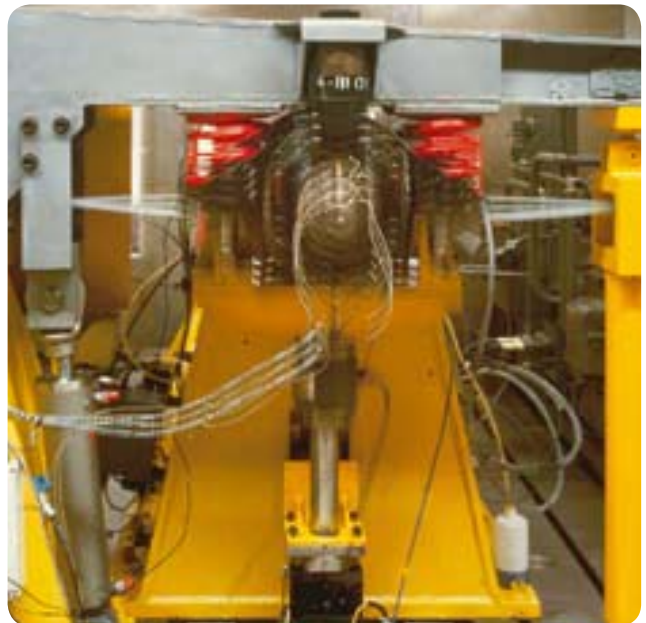

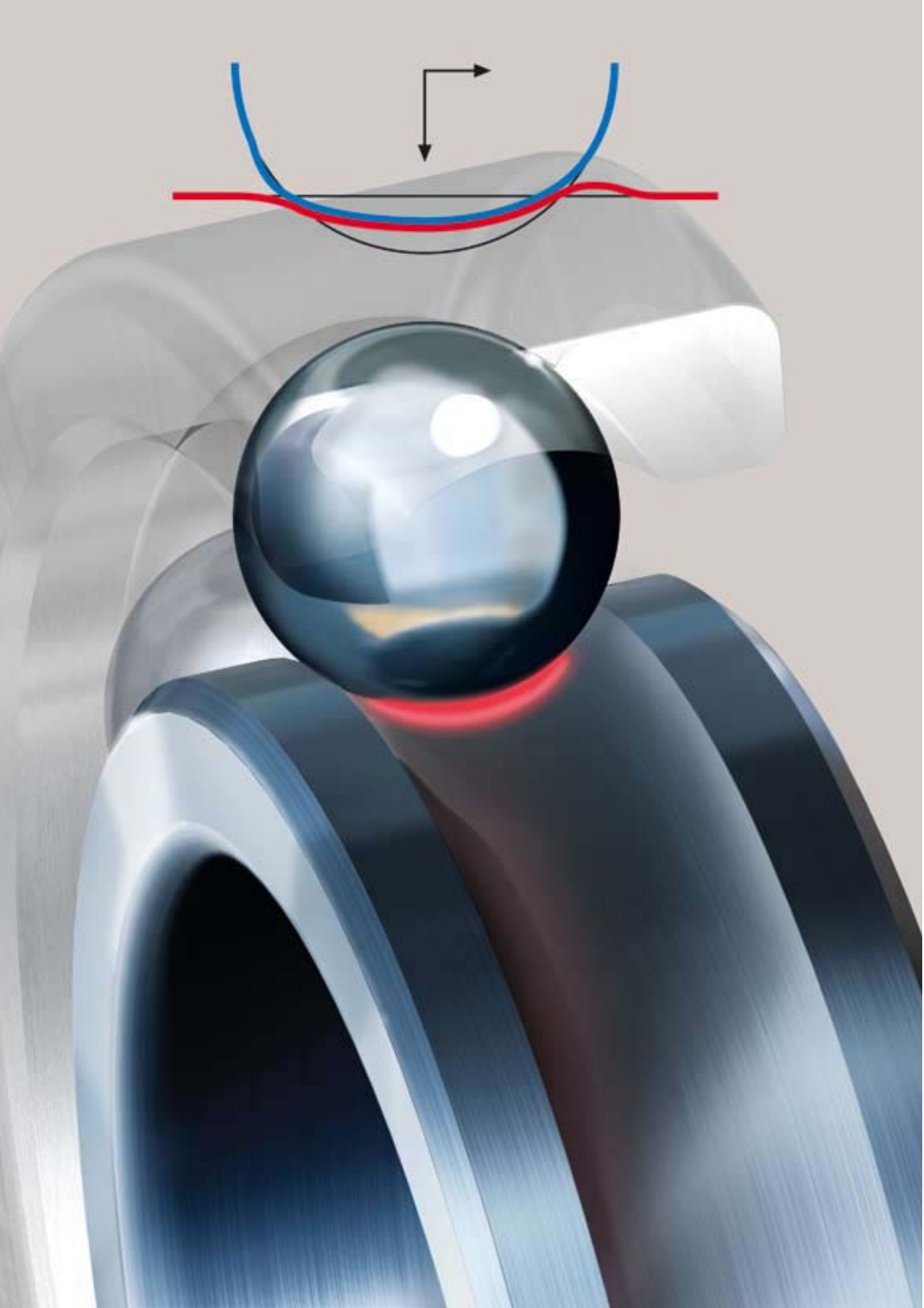

Friction

Estimation of the frictional moment	88
More accurate calculation of the frictional moment.....	88
The new SKF model for calculation of the frictional moment.....	89
Rolling frictional moment	90
Sliding frictional moment	90
Frictional moment of seals.....	90
Additional effects on frictional moments in bearings	96
Inlet shear heating reduction factor	97
Kinematic replenishment/starvation reduction factor	98
Drag losses in oil bath lubrication.....	98
Mixed lubrication for low speeds and viscosities.....	100
Effect of clearance and misalignment on friction.....	101
Effect of grease filling on friction	102
Frictional behaviour of hybrid bearings	102
Starting torque	103
Power loss and bearing temperature.....	103
Calculation example	104

Friction

The friction in a rolling bearing is the determining factor where heat generation in the bearing is concerned and consequently for the operating temperature.

The amount of friction depends on the load and on several other factors, the most important of which are the bearing type and size, the operating speed, the properties of the lubricant and the quantity of lubricant.

The total resistance to rotation of a bearing is made up of the rolling and sliding friction in the rolling contacts, in the contact areas between rolling elements and cage, as well as in the guiding surfaces for the rolling elements or the cage, the friction in the lubricant and the sliding friction of contact seals when applicable.

Estimation of the frictional moment

Under certain conditions

- bearing load $P \approx 0,1 C$
- good lubrication
- normal operating conditions

the frictional moment can be calculated with sufficient accuracy using a constant coefficient of friction μ from the following equation

$$M = 0,5 \mu P d$$

where

M = frictional moment, Nmm

μ = constant coefficient of friction for the bearing (\rightarrow **table 1**)

P = equivalent dynamic bearing load, N

d = bearing bore diameter, mm

More accurate calculation of the frictional moment

One approach to calculate the frictional moment of a rolling bearing is to divide the frictional moment into a so-called load independent moment M_0 and a load dependent moment M_1 and add them together later, giving

$$M = M_0 + M_1$$

This has been the approach until recently. However, more accurate methods are available if the division is based on the type of friction source rather than on its dependency on load. In fact, M_0 accounts for the additional external sources of friction, together with the “hydro-dynamic” component of rolling friction, which also has a load dependent part.

Table 1

Constant coefficient of friction μ for unsealed bearings	
Bearing type	Coefficient of friction μ
Deep groove ball bearings	0,0015
Angular contact ball bearings	
– single row	0,0020
– double row	0,0024
– four-point contact	0,0024
Self-aligning ball bearings	0,0010
Cylindrical roller bearings	
– with cage, when $F_a \approx 0$	0,0011
– full complement, when $F_a \approx 0$	0,0020
Taper roller bearings	0,0018
Spherical roller bearings	0,0018
CARB toroidal roller bearings	0,0016
Thrust ball bearings	0,0013
Cylindrical roller thrust bearings	0,0050
Spherical roller thrust bearings	0,0018

To accurately calculate the frictional moment in a rolling bearing, four different sources must be taken into account

$$M = M_{rr} + M_{sl} + M_{seal} + M_{drag}$$

where

- M = total frictional moment, Nmm
- M_{rr} = rolling frictional moment, Nmm
- M_{sl} = sliding frictional moment, Nmm
- M_{seal} = frictional moment of the seal(s), Nmm
- M_{drag} = frictional moment of drag losses, churning, splashing etc, Nmm

This new approach identifies the sources of friction in every contact occurring in the bearing and combines them; in addition the seal contribution and additional external sources can be added as required to predict the overall frictional moment. Since the model looks into every single contact (raceways and flanges), changes of design and improvements of the surfaces can readily be taken into consideration, making the model more able to reflect improvements in SKF bearing designs and easier to update.

In the following sections the new SKF model for calculating frictional moments starts with the simplest form of the rolling, sliding and seal contributions. In the next section the effects of the oil level in the bearing, high-speed starvation, inlet shear heating and mixed lubrication will be described.

The new SKF model for calculation of the frictional moment

The new SKF model for calculating the frictional moment enables a more accurate calculation of the frictional moment generated in SKF rolling bearings according to the equation

$$M = M_{rr} + M_{sl} + M_{seal} + M_{drag}$$

The new SKF model is derived from more advanced computational models developed by SKF and is designed to provide approximate reference values, under the following application conditions:

- Grease lubrication or normal methods of oil lubrication: oil bath, oil-spot and oil jet.
- For paired bearings, calculate the frictional moment for each bearing separately and then add them up. The radial load is divided equally over the two bearings; the axial load is shared according to the bearing arrangement.
- Loads equal to or larger than the recommended minimum load.
- Constant loads in magnitude and direction.
- Normal operational clearance.

Note

The formulae provided here lead to rather complex calculations. It is therefore strongly advised to make use of the calculation facilities provided in the “SKF Interactive Engineering Catalogue” available on CD-ROM or online at www.skf.com.

Friction

Rolling frictional moment

The rolling frictional moment is calculated from the equation

$$M_{rr} = G_{rr} (v n)^{0,6}$$

where

M_{rr} = rolling frictional moment, Nmm

G_{rr} = a variable that depends on

- the bearing type
- the bearing mean diameter d_m
= 0,5 (d + D), mm
- the radial load F_r , N
- the axial load F_a , N

n = rotational speed, r/min

v = kinematic viscosity of the lubricant at the operating temperature, mm^2/s (for grease lubrication the base oil viscosity)

The values for G_{rr} can be obtained using the equations provided in **table 2** and the geometry constants R provided in **table 3**, starting on **page 92**. Both loads, F_r and F_a , are always considered as positive.

Sliding frictional moment

The sliding frictional moment is calculated using

$$M_{sl} = G_{sl} \mu_{sl}$$

where

M_{sl} = sliding frictional moment, Nmm

G_{sl} = a variable that depends on

- the bearing type,
- the bearing mean diameter d_m
= 0,5 (d + D), mm
- the radial load F_r , N
- the axial load F_a , N

μ_{sl} = sliding friction coefficient, which can be set to the value for full film conditions, i.e. $\kappa \geq 2$,
0,05 for lubrication with mineral oils
0,04 for lubrication with synthetic oils
0,1 for lubrication with transmission fluids
For cylindrical or taper roller bearings use the following values instead:
0,02 for cylindrical roller bearings
0,002 for taper roller bearings

The values for G_{sl} can be obtained using the equations provided in **table 2** and the geometry

constants S provided in **table 3**, starting on **page 92**.

Frictional moment of seals

Where bearings are fitted with contact seals the frictional losses arising from the seal may exceed those generated in the bearing. The frictional moment on seals for bearings that are sealed on both sides can be estimated using the following empirical equation

$$M_{\text{seal}} = K_{S1} d_S^\beta + K_{S2}$$

where

M_{seal} = frictional moment of seals, Nmm

K_{S1} = constant depending on the bearing type

K_{S2} = constant depending on bearing and seal type

d_S = seal counterface diameter (**→ table 4, page 96**)

β = exponent depending on bearing and seal type

Values for constants K_{S1} , and K_{S2} and exponent β can be found in **table 4, page 96**.

M_{seal} is the frictional moment generated by two seals. In case there is one seal only, the friction generated is 0,5 M_{seal} .

For RSL seals for deep groove ball bearings with an outside diameter over 25 mm, use the calculated value of M_{seal} irrespective whether there is one or two seals.

Table 2a

Geometry and load dependent variables for rolling and sliding frictional moments – radial bearings		
Bearing type	Rolling friction variable G_{rr}	Sliding frictional variable G_{sl}
Deep groove ball bearings	when $F_a = 0$ $G_{rr} = R_1 d_m^{1,96} F_r^{0,54}$ when $F_a > 0$ $G_{rr} = R_1 d_m^{1,96} \left(F_r + \frac{R_2}{\sin \alpha_f} F_a \right)^{0,54}$ $\alpha_f = 24,6 (F_a/C_0)^{0,24}$, degrees	when $F_a = 0$ $G_{sl} = S_1 d_m^{-0,26} F_r^{5/3}$ when $F_a > 0$ $G_{sl} = S_1 d_m^{-0,145} \left(F_r^5 + \frac{S_2 d_m^{1,5}}{\sin \alpha_f} F_a^4 \right)^{1/3}$
Angular contact ball bearings¹⁾	$G_{rr} = R_1 d_m^{1,97} [F_r + F_g + R_2 F_a]^{0,54}$ $F_g = R_3 d_m^4 n_2$	$G_{sl} = S_1 d_m^{0,26} [(F_r + F_g)^{4/3} + S_2 F_a^{4/3}]$ $F_g = S_3 d_m^4 n_2$
Four-point contact ball bearings	$G_{rr} = R_1 d_m^{1,97} [F_r + F_g + R_2 F_a]^{0,54}$ $F_g = R_3 d_m^4 n^2$	$G_{sl} = S_1 d_m^{0,26} [(F_r + F_g)^{4/3} + S_2 F_a^{4/3}]$ $F_g = S_3 d_m^4 n^2$
Self-aligning ball bearings	$G_{rr} = R_1 d_m^2 [F_r + F_g + R_2 F_a]^{0,54}$ $F_g = R_3 d_m^{3,5} n^2$	$G_{sl} = S_1 d_m^{-0,12} [(F_r + F_g)^{4/3} + S_2 F_a^{4/3}]$ $F_g = S_3 d_m^{3,5} n^2$
Cylindrical roller bearings	$G_{rr} = R_1 d_m^{2,41} F_r^{0,31}$	$G_{sl} = S_1 d_m^{0,9} F_a + S_2 d_m F_r$
Taper roller bearings¹⁾ For axial load factor Y for single row bearings → product tables	$G_{rr} = R_1 d_m^{2,38} (F_r + R_2 Y F_a)^{0,31}$	$G_{sl} = S_1 d_m^{0,82} (F_r + S_2 Y F_a)$
Spherical roller bearings	$G_{rr,e} = R_1 d_m^{1,85} (F_r + R_2 F_a)^{0,54}$ $G_{rr,l} = R_3 d_m^{2,3} (F_r + R_4 F_a)^{0,31}$ when $G_{rr,e} < G_{rr,l}$ $G_{rr} = G_{rr,e}$ otherwise $G_{rr} = G_{rr,l}$	$G_{sl,e} = S_1 d_m^{0,25} (F_r^4 + S_2 F_a^4)^{1/3}$ $G_{sl,l} = S_3 d_m^{0,94} (F_r^3 + S_4 F_a^3)^{1/3}$ when $G_{sl,e} < G_{sl,l}$ $G_{sl} = G_{sl,e}$ otherwise $G_{sl} = G_{sl,l}$
CARB toroidal roller bearings	when $F_r < (R_2^{1,85} d_m^{0,78}/R_1^{1,85})^{2,35}$ $G_{rr,e} = R_1 d_m^{1,97} F_r^{0,54}$ otherwise $G_{rr,l} = R_2 d_m^{2,37} F_r^{0,31}$	when $F_r < (S_2 d_m^{1,24}/S_1)^{1,5}$ $G_{sl,e} = S_1 d_m^{-0,19} F_r^{5/3}$ otherwise $G_{sl,l} = S_2 d_m^{1,05} F_r$

¹⁾The value to be used for F_a is the external axial load

Table 2b

Geometry and load dependent variables for rolling and sliding frictional moments – thrust bearings		
Bearing type	Rolling friction variable G_{rr}	Sliding friction variable G_{sl}
Thrust ball bearings	$G_{rr} = R_1 d_m^{1,83} F_a^{0,54}$	$G_{sl} = S_1 d_m^{0,05} F_a^{4/3}$
Cylindrical roller thrust bearings	$G_{rr} = R_1 d_m^{2,38} F_a^{0,31}$	$G_{sl} = S_1 d_m^{0,62} F_a$
Spherical roller thrust bearings	$G_{rr,e} = R_1 d_m^{1,96} (F_r + R_2 F_a)^{0,54}$ $G_{rr,l} = R_3 d_m^{2,39} (F_r + R_4 F_a)^{0,31}$ when $G_{rr,e} < G_{rr,l}$ $G_{rr} = G_{rr,e}$ otherwise $G_{rr} = G_{rr,l}$	$G_{sl,e} = S_1 d_m^{-0,35} (F_r^{5/3} + S_2 F_a^{5/3})$ $G_{sl,l} = S_3 d_m^{0,89} (F_r + F_a)$ when $G_{sl,e} < G_{sl,l}$ $G_{sr} = G_{sl,e}$ otherwise $G_{sr} = G_{sl,l}$ $G_f = S_4 d_m^{0,76} (F_r + S_5 F_a)$ $G_{sl} = G_{sr} + \frac{G}{e^{10^{-6} (n v)^{1,4} d_m}}$

Table 3

Geometry constants for rolling and sliding frictional moments						
Bearing type	Geometry constants for rolling frictional moments			sliding frictional moments		
	R_1	R_2	R_3	S_1	S_2	S_3
Deep groove ball bearings	See table 3a			See table 3a		
Angular contact ball bearings						
– single row	$5,03 \times 10^{-7}$	1,97	$1,90 \times 10^{-12}$	$1,30 \times 10^{-2}$	0,68	$1,91 \times 10^{-12}$
– double row	$6,34 \times 10^{-7}$	1,41	$7,83 \times 10^{-13}$	$7,56 \times 10^{-3}$	1,21	$7,83 \times 10^{-13}$
– four-point contact	$4,78 \times 10^{-7}$	2,42	$1,40 \times 10^{-12}$	$1,20 \times 10^{-2}$	0,9	$1,40 \times 10^{-12}$
Self-aligning ball bearings	See table 3b			See table 3b		
Cylindrical roller bearings	See table 3c			See table 3c		
Taper roller bearings	See table 3d			See table 3d		
Spherical roller bearings	See table 3e			See table 3e		
CARB toroidal roller bearings	See table 3f			See table 3f		
Thrust ball bearings	$1,03 \times 10^{-6}$			$1,6 \times 10^{-2}$		
Cylindrical roller thrust bearings	$2,25 \times 10^{-6}$			0,154		
Spherical roller thrust bearings	See table 3g			See table 3g		

Table 3a

Geometry constants for rolling and sliding frictional moments of deep groove ball bearings				
Bearing series	Geometry constants for rolling frictional moments		sliding frictional moments	
	R ₁	R ₂	S ₁	S ₂
2, 3	$4,4 \times 10^{-7}$	1,7	$2,00 \times 10^{-3}$	100
42, 43	$5,4 \times 10^{-7}$	0,96	$3,00 \times 10^{-3}$	40
60, 630	$4,1 \times 10^{-7}$	1,7	$3,73 \times 10^{-3}$	14,6
62, 622	$3,9 \times 10^{-7}$	1,7	$3,23 \times 10^{-3}$	36,5
63, 623	$3,7 \times 10^{-7}$	1,7	$2,84 \times 10^{-3}$	92,8
64	$3,6 \times 10^{-7}$	1,7	$2,43 \times 10^{-3}$	198
160, 161	$4,3 \times 10^{-7}$	1,7	$4,63 \times 10^{-3}$	4,25
617, 618, 628, 637, 638	$4,7 \times 10^{-7}$	1,7	$6,50 \times 10^{-3}$	0,78
619, 639	$4,3 \times 10^{-7}$	1,7	$4,75 \times 10^{-3}$	3,6

Table 3b

Geometry constants for rolling and sliding frictional moments of self-aligning ball bearings						
Bearing series	Geometry constants for rolling frictional moments			sliding frictional moments		
	R ₁	R ₂	R ₃	S ₁	S ₂	S ₃
12	$3,25 \times 10^{-7}$	6,51	$2,43 \times 10^{-12}$	$4,36 \times 10^{-3}$	9,33	$2,43 \times 10^{-12}$
13	$3,11 \times 10^{-7}$	5,76	$3,52 \times 10^{-12}$	$5,76 \times 10^{-3}$	8,03	$3,52 \times 10^{-12}$
22	$3,13 \times 10^{-7}$	5,54	$3,12 \times 10^{-12}$	$5,84 \times 10^{-3}$	6,60	$3,12 \times 10^{-12}$
23	$3,11 \times 10^{-7}$	3,87	$5,41 \times 10^{-12}$	0,01	4,35	$5,41 \times 10^{-12}$
112	$3,25 \times 10^{-7}$	6,16	$2,48 \times 10^{-12}$	$4,33 \times 10^{-3}$	8,44	$2,48 \times 10^{-12}$
130	$2,39 \times 10^{-7}$	5,81	$1,10 \times 10^{-12}$	$7,25 \times 10^{-3}$	7,98	$1,10 \times 10^{-12}$
139	$2,44 \times 10^{-7}$	7,96	$5,63 \times 10^{-13}$	$4,51 \times 10^{-3}$	12,11	$5,63 \times 10^{-13}$

Table 3c

Geometry constants for rolling and sliding frictional moments of cylindrical roller bearings			
Bearing series	Geometry constants for rolling frictional moment	sliding frictional moments	
	S ₁	S ₂	S ₃
Bearing with cage of the N, NU, NJ or NUP design			
2, 3	$1,09 \times 10^{-6}$	0,16	0,0015
4	$1,00 \times 10^{-6}$	0,16	0,0015
10	$1,12 \times 10^{-6}$	0,17	0,0015
12, 20	$1,23 \times 10^{-6}$	0,16	0,0015
22	$1,40 \times 10^{-6}$	0,16	0,0015
23	$1,48 \times 10^{-6}$	0,16	0,0015
Full complement bearings of the NCF, NJG, NNC, NNCF, NNC or NNF design			
All series	$2,13 \times 10^{-6}$	0,16	0,0015

Table 3d

Geometry constants for rolling and sliding frictional moments of taper roller bearings				
Bearing series	Geometry constants for rolling frictional moments		sliding frictional moments	
	R ₁	R ₂	S ₁	S ₂
302	1,76 × 10 ⁻⁶	10,9	0,017	2
303	1,69 × 10 ⁻⁶	10,9	0,017	2
313 (X)	1,84 × 10 ⁻⁶	10,9	0,048	2
320 X	2,38 × 10 ⁻⁶	10,9	0,014	2
322	2,27 × 10 ⁻⁶	10,9	0,018	2
322 B	2,38 × 10 ⁻⁶	10,9	0,026	2
323	2,38 × 10 ⁻⁶	10,9	0,019	2
323 B	2,79 × 10 ⁻⁶	10,9	0,030	2
329	2,31 × 10 ⁻⁶	10,9	0,009	2
330	2,71 × 10 ⁻⁶	11,3	0,010	2
331	2,71 × 10 ⁻⁶	10,9	0,015	2
332	2,71 × 10 ⁻⁶	10,9	0,018	2
LL	1,72 × 10 ⁻⁶	10,9	0,0057	2
L	2,19 × 10 ⁻⁶	10,9	0,0093	2
LM	2,25 × 10 ⁻⁶	10,9	0,011	2
M	2,48 × 10 ⁻⁶	10,9	0,015	2
HM	2,60 × 10 ⁻⁶	10,9	0,020	2
H	2,66 × 10 ⁻⁶	10,9	0,025	2
HH	2,51 × 10 ⁻⁶	10,9	0,027	2
All other	2,31 × 10 ⁻⁶	10,9	0,019	2

Table 3e

Geometry constants for rolling and sliding frictional moments of spherical roller bearings								
Bearing series	Geometry constants for rolling frictional moments				sliding frictional moments			
	R ₁	R ₂	R ₃	R ₄	S ₁	S ₂	S ₃	S ₄
213 E, 222 E	1,6 × 10 ⁻⁶	5,84	2,81 × 10 ⁻⁶	5,8	3,62 × 10 ⁻³	508	8,8 × 10 ⁻³	117
222	2,0 × 10 ⁻⁶	5,54	2,92 × 10 ⁻⁶	5,5	5,10 × 10 ⁻³	414	9,7 × 10 ⁻³	100
223	1,7 × 10 ⁻⁶	4,1	3,13 × 10 ⁻⁶	4,05	6,92 × 10 ⁻³	124	1,7 × 10 ⁻²	41
223 E	1,6 × 10 ⁻⁶	4,1	3,14 × 10 ⁻⁶	4,05	6,23 × 10 ⁻³	124	1,7 × 10 ⁻²	41
230	2,4 × 10 ⁻⁶	6,44	3,76 × 10 ⁻⁶	6,4	4,13 × 10 ⁻³	755	1,1 × 10 ⁻²	160
231	2,4 × 10 ⁻⁶	4,7	4,04 × 10 ⁻⁶	4,72	6,70 × 10 ⁻³	231	1,7 × 10 ⁻²	65
232	2,3 × 10 ⁻⁶	4,1	4,00 × 10 ⁻⁶	4,05	8,66 × 10 ⁻³	126	2,1 × 10 ⁻²	41
238	3,1 × 10 ⁻⁶	12,1	3,82 × 10 ⁻⁶	12	1,74 × 10 ⁻³	9 495	5,9 × 10 ⁻³	1 057
239	2,7 × 10 ⁻⁶	8,53	3,87 × 10 ⁻⁶	8,47	2,77 × 10 ⁻³	2 330	8,5 × 10 ⁻³	371
240	2,9 × 10 ⁻⁶	4,87	4,78 × 10 ⁻⁶	4,84	6,95 × 10 ⁻³	240	2,1 × 10 ⁻²	68
241	2,6 × 10 ⁻⁶	3,8	4,79 × 10 ⁻⁶	3,7	1,00 × 10 ⁻²	86,7	2,9 × 10 ⁻²	31
248	3,8 × 10 ⁻⁶	9,4	5,09 × 10 ⁻⁶	9,3	2,80 × 10 ⁻³	3 415	1,2 × 10 ⁻²	486
249	3,0 × 10 ⁻⁶	6,67	5,09 × 10 ⁻⁶	6,62	3,90 × 10 ⁻³	887	1,7 × 10 ⁻²	180

Table 3f

Geometry constants for rolling and sliding frictional moments of CARB toroidal roller bearings

Bearing series	Geometry constants for rolling frictional moments		sliding frictional moments	
	R ₁	R ₂	S ₁	S ₂
C 22	1,17 × 10 ⁻⁶	2,08 × 10 ⁻⁶	1,32 × 10 ⁻³	0,8 × 10 ⁻²
C 23	1,20 × 10 ⁻⁶	2,28 × 10 ⁻⁶	1,24 × 10 ⁻³	0,9 × 10 ⁻²
C 30	1,40 × 10 ⁻⁶	2,59 × 10 ⁻⁶	1,58 × 10 ⁻³	1,0 × 10 ⁻²
C 31	1,37 × 10 ⁻⁶	2,77 × 10 ⁻⁶	1,30 × 10 ⁻³	1,1 × 10 ⁻²
C 32	1,33 × 10 ⁻⁶	2,63 × 10 ⁻⁶	1,31 × 10 ⁻³	1,1 × 10 ⁻²
C 39	1,45 × 10 ⁻⁶	2,55 × 10 ⁻⁶	1,84 × 10 ⁻³	1,0 × 10 ⁻²
C 40	1,53 × 10 ⁻⁶	3,15 × 10 ⁻⁶	1,50 × 10 ⁻³	1,3 × 10 ⁻²
C 41	1,49 × 10 ⁻⁶	3,11 × 10 ⁻⁶	1,32 × 10 ⁻³	1,3 × 10 ⁻²
C 49	1,49 × 10 ⁻⁶	3,24 × 10 ⁻⁶	1,39 × 10 ⁻³	1,5 × 10 ⁻²
C 59	1,77 × 10 ⁻⁶	3,81 × 10 ⁻⁶	1,80 × 10 ⁻³	1,8 × 10 ⁻²
C 60	1,83 × 10 ⁻⁶	5,22 × 10 ⁻⁶	1,17 × 10 ⁻³	2,8 × 10 ⁻²
C 69	1,85 × 10 ⁻⁶	4,53 × 10 ⁻⁶	1,61 × 10 ⁻³	2,3 × 10 ⁻²

Table 3g

Geometry constants for rolling and sliding frictional moments of spherical roller thrust bearings

Bearing series	Geometry constants for rolling frictional moments				sliding frictional moments				
	R ₁	R ₂	R ₃	R ₄	S ₁	S ₂	S ₃	S ₄	S ₅
292	1,32 × 10 ⁻⁶	1,57	1,97 × 10 ⁻⁶	3,21	4,53 × 10 ⁻³	0,26	0,02	0,1	0,6
292 E	1,32 × 10 ⁻⁶	1,65	2,09 × 10 ⁻⁶	2,92	5,98 × 10 ⁻³	0,23	0,03	0,17	0,56
293	1,39 × 10 ⁻⁶	1,66	1,96 × 10 ⁻⁶	3,23	5,52 × 10 ⁻³	0,25	0,02	0,1	0,6
293 E	1,16 × 10 ⁻⁶	1,64	2,00 × 10 ⁻⁶	3,04	4,26 × 10 ⁻³	0,23	0,025	0,15	0,58
294 E	1,25 × 10 ⁻⁶	1,67	2,15 × 10 ⁻⁶	2,86	6,42 × 10 ⁻³	0,21	0,04	0,2	0,54

Table 4

Seal frictional moment: Calculation of exponent and constants						
Seal type Bearing type	Bearing outside diameter		Exponent and constants			Seal counter-face diameter $d_s^{1)}$
	D over	incl.	β	K_{S1}	K_{S2}	
RSL seals Deep groove ball bearings	25	25 52	0 2,25	0 0,0018	0 0	d_2 d_2
RZ seals Deep groove ball bearings		175	0	0	0	d_1
RSH seals Deep groove ball bearings		52	2,25	0,028	2	d_2
RS1 seals Deep groove ball bearings		62 80 100	2,25 2,25 2,25 2,25	0,023 0,018 0,018 0,018	2 20 15 0	d_1, d_2 d_1, d_2 d_1, d_2 d_1, d_2
Angular contact ball bearings	30	120	2	0,014	10	d_1
Self-aligning ball bearings	30	125	2	0,014	10	d_2
LS seals Cylindrical roller bearings	42	360	2	0,032	50	E
CS, CS2 and CS5 seals Spherical roller bearings	62	300	2	0,057	50	d_2
CARB toroidal roller bearings	42	340	2	0,057	50	d_2

¹⁾ Designation of the dimension listed in the product table

Additional effects on frictional moments in bearings

In order to follow more closely the real behaviour of the bearing, and if an even more accurate calculation is needed, the new SKF model is able to consider additional effects which can be added into the equation. Those additional effects include

- inlet shear heating reduction
- replenishment/starvation speed effects for oil-spot, oil jet, grease and low level oil bath lubrication
- drag loss effects in oil bath lubrication
- mixed lubrication for low speeds and/or low viscosities.

Including these additional sources, the final equation for the total frictional moment of a bearing is

$$M = \phi_{ish} \phi_{rs} M_{rr} + M_{sl} + M_{seal} + M_{drag}$$

where

M = total frictional moment of a bearing, Nmm

$$M_{rr} = G_{rr} (v n)^{0,6}$$

$$M_{sl} = G_{sl} \mu_{sl}$$

$$M_{seal} = K_{S1} d_s^\beta + K_{S2}$$

M_{drag} = frictional moment of drag losses, churning, splashing etc, Nmm

ϕ_{ish} = inlet shear heating reduction factor

ϕ_{rs} = kinematic replenishment/starvation reduction factor

The reduction factors ϕ_{ish} and ϕ_{rs} are introduced in the new SKF friction model to account for the effects of inlet shear heating reduction and high-speed replenishment/starvation of rolling friction, respectively. The sliding friction coefficient μ_{sl} increases for low speeds and/or viscosity to account for the mixed lubrication regime.

Inlet shear heating reduction factor

When sufficient lubricant is available in the bearing, not all of it can go through the contacts; only a tiny amount of lubricant is used to build-up the film thickness. Due to this effect, some of the oil close to the contact inlet will be rejected and will produce reverse flow (→ **fig. 1**). This reverse flow shears the lubricant, generating heat that lowers the oil viscosity and reduces the film thickness and rolling friction component.

For the effect described above, the inlet shear heating reduction factor can be obtained approximately from

$$\phi_{ish} = \frac{1}{1 + 1,84 \times 10^{-9} (n d_m)^{1,28} v^{0,64}}$$

where

ϕ_{ish} = inlet shear heating reduction factor

n = rotational speed, r/min

d_m = bearing mean diameter
= 0,5 (d+D), mm

v = kinematic viscosity of the lubricant at the operating temperature, mm²/s (for grease lubrication the base oil viscosity)

Values for the inlet shear heating factor ϕ_{ish} can be obtained from **diagram 1** as a function of the combined parameter $(n d_m)^{1,28} v^{0,64}$.

Fig. 1

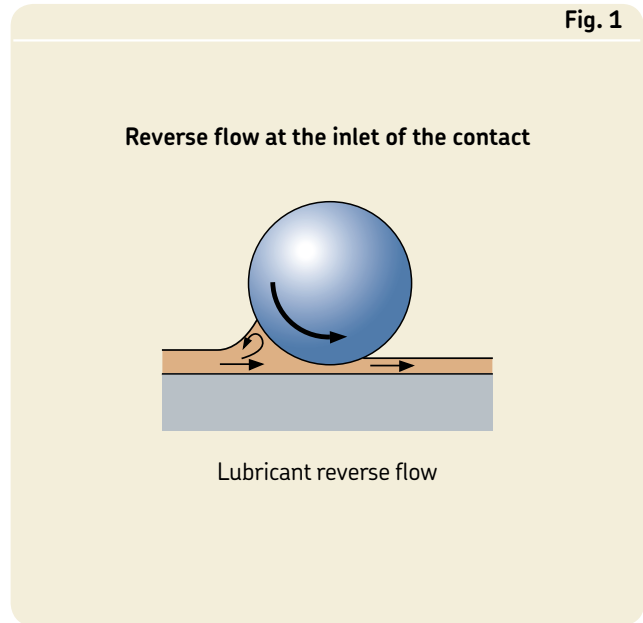
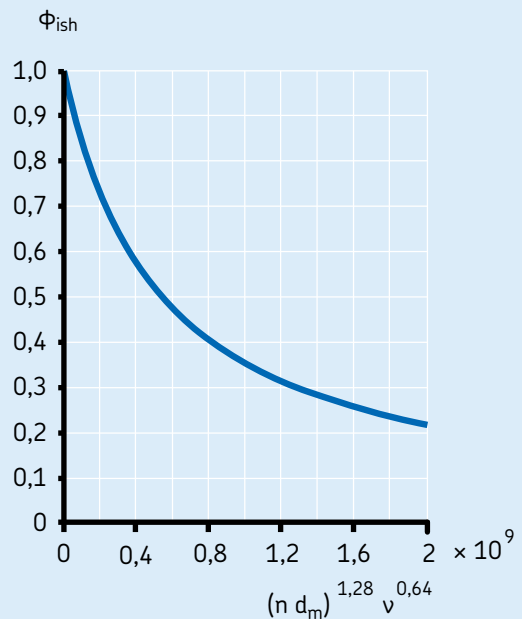

Diagram 1

Inlet shear heating factor ϕ_{ish}



Kinematic replenishment/starvation reduction factor

For oil-spot, oil jet, low level oil bath lubrication conditions (e.g. oil level lower than the lowest rolling element centre) and grease lubrication, subsequent overrolling of the raceways might push away the excess of lubricant. Due to the bearing speed or high viscosity, the lubricant at the edges of the contacts might not have sufficient time to replenish the raceways, this effect is called “kinematic starvation” and causes a drop in the film thickness and in the rolling friction.

For the type of lubrication conditions described above, the kinematic replenishment/starvation reduction factor can be obtained approximately from

$$\phi_{rs} = \frac{1}{e^{K_{rs} \nu n (d + D)} \sqrt{\frac{K_z}{2(D-d)}}}$$

where

ϕ_{rs} = kinematic replenishment/starvation reduction factor

e = base of natural logarithm $\approx 2,718$

K_{rs} = the replenishment/starvation constant
 3×10^{-8} for low level oil bath and oil jet lubrication

6×10^{-8} for grease and oil-spot lubrication

K_z = bearing type related geometry constant (→ table 5)

ν = kinematic viscosity at the operating temperature, mm^2/s

n = rotational speed, r/min

d = bearing bore diameter, mm

D = bearing outside diameter, mm

Drag losses in oil bath lubrication

As drag losses are the most important additional sources of friction, the additional source term therefore is reduced to the drag losses component M_{drag} .

In oil bath lubrication, the bearing is partially, or in special situations, completely submerged. Under these conditions the size and geometry of the oil reservoir together with the oil level used can have a substantial impact on the bearing frictional moment. For a very large oil bath, disregarding any reservoir size interaction and

any influence of other mechanical elements working close to the bearing, e.g. external oil agitation, gears or cams, the drag losses in a bearing as a function of the oil level in the reservoir can be approximated from the variable V_M plotted in **diagram 2** as a function of the oil level H (→ **fig. 2**) and the bearing mean diameter $d_m = 0,5 (d + D)$. **Diagram 2** can be applied for bearing speeds up to the reference speed of the bearing. At higher speeds and high oil levels other effects might have an important influence in the results.

The variable V_M in **diagram 2** is related to the frictional moment of drag losses for ball bearings by

Table 5

Geometry constants K_z and K_L		
Bearing type	Geometry constants	
	K_z	K_L
Deep groove ball bearings – single and double row	3,1	–
Angular contact ball bearings – single row	4,4	–
– double row	3,1	–
– four-point contact	3,1	–
Self-aligning ball bearings	4,8	–
Cylindrical roller bearings – with cage	5,1	0,65
– full complement	6,2	0,7
Taper roller bearings	6	0,7
Spherical roller bearings	5,5	0,8
CARB toroidal roller bearings – with cage	5,3	0,8
– full complement	6	0,75
Thrust ball bearings	3,8	–
Cylindrical roller thrust bearings	4,4	0,43
Spherical roller thrust bearings	5,6	0,58 ¹⁾

¹⁾ Only for single mounted bearings

$$M_{\text{drag}} = V_M K_{\text{ball}} d_m^5 n^2$$

and for roller bearings by

$$M_{\text{drag}} = 10 V_M K_{\text{roll}} B d_m^4 n^2$$

where

M_{drag} = frictional moment of drag losses, Nmm

V_M = variable as a function of the oil level according to **diagram 2**

K_{ball} = ball bearing related constant, see below

K_{roll} = roller bearing related constant, see below

d_m = bearing mean diameter, mm

B = bearing inner ring width, mm

n = rotational speed, r/min

Values for the variable V_M can be obtained in **diagram 2**, from the red curve for ball bearings and from the blue curve for roller bearings.

The ball bearing related constant is defined as

$$K_{\text{ball}} = \frac{i_{\text{rw}} K_Z (d + D)}{D - d} \times 10^{-12}$$

and the roller bearing related constant as

$$K_{\text{roll}} = \frac{K_L K_Z (d + D)}{D - d} \times 10^{-12}$$

where

K_{ball} = ball bearing related constant

K_{roll} = roller bearing related constant

i_{rw} = the number of ball rows

K_Z = bearing type related geometry constant (**→ table 5, page 98**)

K_L = roller bearing type related geometry constant (**→ table 5, page 98**)

d = bearing bore diameter, mm

D = bearing outside diameter, mm

Note

To calculate drag losses for oil jet lubrication, one can use the oil bath model, with the oil level to half the roller diameter and multiply the obtained value for M_{drag} by a factor of two.

To calculate drag losses for vertical shaft arrangements an approximate value can be obtained by using the model for fully submerged bearings and multiply the obtained value for M_{drag} by a factor equal to that width (height) that

Fig. 2

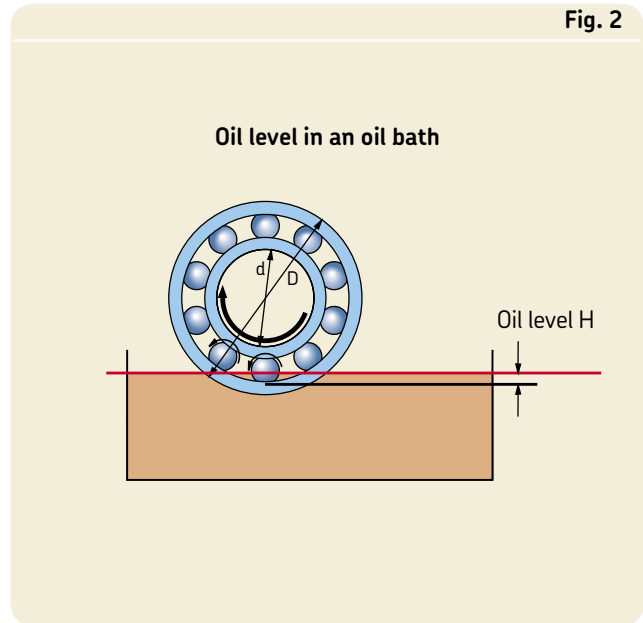
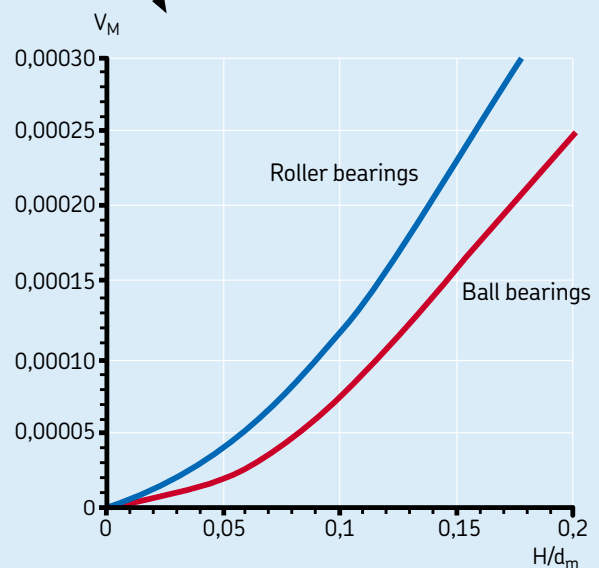
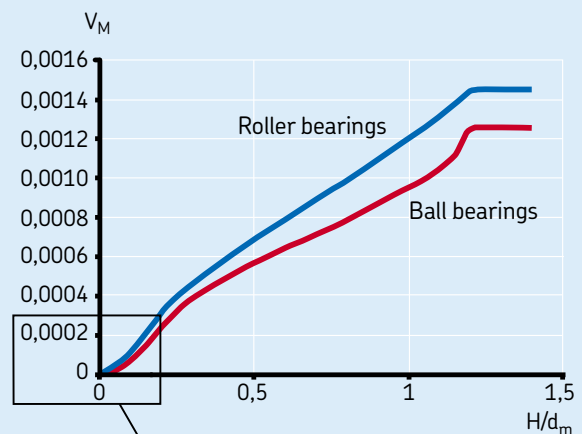

Diagram 2

Drag loss variable V_M



Friction

is submerged relative to the total bearing width (height).

Mixed lubrication for low speeds and viscosities

For operating conditions of small κ values (≤ 2) the application lies in the mixed lubrication regime; occasional metal-to-metal contact may occur, which increases friction. A sketch of a typical bearing frictional moment as a function of rotational speed and viscosity is depicted in **diagram 3**. During the start-up period with increasing speed or viscosity the frictional moment decreases, since a lubricating film is built up and the bearing enters into the full elasto-hydrodynamic (EHL) regime. With higher speeds or viscosities friction increases due to the increase of film thickness until high-speed starvation and thermal effects reduce friction again.

The sliding friction coefficient can be calculated with the following equation

$$\mu_{sl} = \phi_{bl} \mu_{bl} + (1 - \phi_{bl}) \mu_{EHL}$$

where

μ_{sl} = sliding friction coefficient

ϕ_{bl} = weighting factor for the sliding friction coefficient, see below

μ_{bl} = coefficient depending on the additive package in the lubricant, approximate value 0,15

μ_{EHL} = friction coefficient in full film conditions:
 0,05 for lubrication with mineral oils
 0,04 for lubrication with synthetic oils
 0,1 for lubrication with transmission fluids

For applications with cylindrical or taper roller bearings, use following values instead:

0,02 for cylindrical roller bearings

0,002 for taper roller bearings

The weighting factor for the sliding frictional moment can be estimated using the following equation

$$\phi_{bl} = \frac{1}{e^{2,6 \times 10^{-8} (n v)^{1,4} d_m}}$$

Diagram 3

Bearing frictional moment as a function of the speed and viscosity

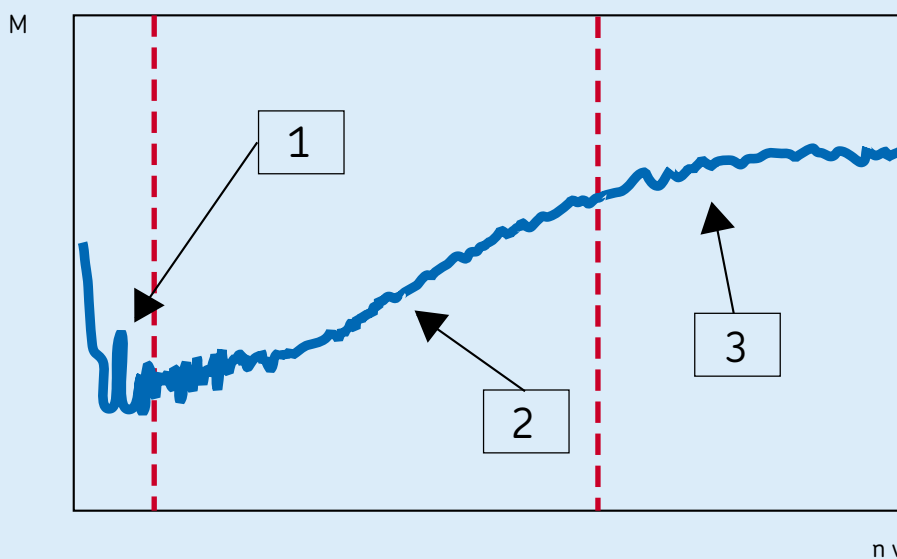

Zone 1: Mixed lubrication
 Zone 2: EHL Elasto-hydrodynamic lubrication
 Zone 3: EHL + thermal and starvation effects

where

ϕ_{bl} = weighting factor for the sliding friction coefficient

e = base of natural logarithm = 2,718

n = operational speed, r/min

ν = kinematic viscosity of the lubricant at the operating temperature, mm²/s (for grease lubrication the base oil viscosity)

d_m = bearing mean diameter, mm

An estimation of the weighting factor ϕ_{bl} for the sliding friction coefficient can be made using the curve shown in **diagram 4**.

Effects of clearance and misalignment on friction

Changes in clearance and/or misalignment in bearings will modify the frictional moment. The above-described model considers normal clearance and an aligned bearing. However, high bearing operating temperatures or high speed might reduce internal bearing clearance, which can increase friction. Misalignment generally increases friction, however, for self-aligning ball bearings, spherical roller bearings, CARB toroidal roller bearings and spherical roller thrust bearings the corresponding increase of friction with misalignment is negligible.

For specific application conditions sensitive to changes of clearance and misalignment please contact the SKF application engineering service.

Diagram 4

Weighting factor ϕ_{bl} for the sliding friction coefficient

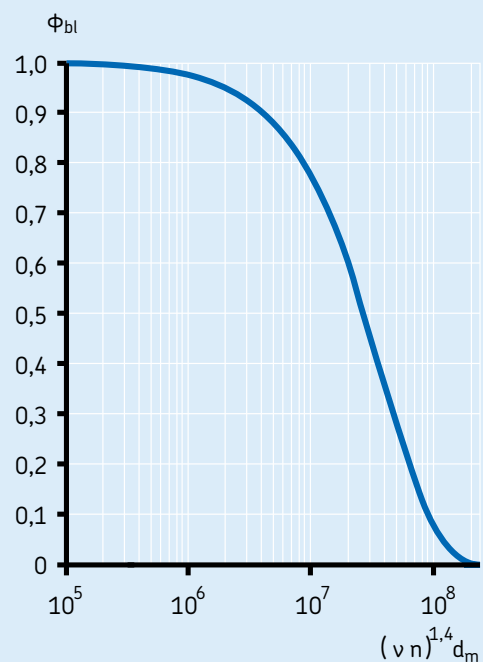

Effects of grease filling on friction

When grease lubrication is used, and the bearing has just been filled (or refilled) with the recommended amount of grease, the bearing can show considerably higher frictional values during the first hours or days of operation (depending on the speed) than had been calculated originally. This is because the grease takes time to redistribute itself within the free space in the bearing; meanwhile it is churned and moved around. To estimate this effect, multiply the initial rolling frictional moment by a factor of 2 for light series and a factor of 4 for heavy series. However, after this “running-in” period, the frictional moment comes down to similar values as oil lubricated bearings; in many cases even lower values are possible. If the bearing is filled with an excessive amount of grease, higher values of friction in the bearing may result. Please refer to the section “Relubrication”, starting on **page 237**, or contact the SKF application engineering service for more detailed information.

Frictional behaviour of hybrid bearings

Due to the higher values for the modulus of elasticity of ceramics, hybrid bearings will have smaller contact areas, which favour a reduction of the rolling and sliding friction components. In addition, the lower density of ceramics compared with steel reduces the centrifugal forces, and this also may reduce friction at high speeds.

In the above equations, the frictional moment for hybrid angular contact ball bearings can be calculated by substituting the geometry constants R_3 and S_3 of the all-steel bearings by $0,41 R_3$ and $0,41 S_3$ respectively.

High speed designs with hybrid deep groove ball bearings include the practise to axially preload the bearing arrangement. The deep groove ball bearings will under such a condition act as angular contact ball bearings and thus see a similar reduction in friction level at high speeds. However, such a friction calculation needs to be done in cooperation with the SKF application engineering service.

Starting torque

The starting torque of a rolling bearing is defined as the frictional moment that must be overcome in order for the bearing to start rotating from the stationary condition. Under normal ambient temperature, +20 to +30 °C, starting at zero speed and $\mu_{sl} = \mu_{bl}$, the starting torque can be calculated using only the sliding frictional moment and the frictional moment of seals, if present. Therefore

$$M_{\text{start}} = M_{\text{sl}} + M_{\text{seal}}$$

where

M_{start} = starting frictional moment, Nmm

M_{sl} = sliding frictional moment, Nmm

M_{seal} = frictional moment of the seals, Nmm

However, the starting torque can be considerably higher for roller bearings with a large contact angle, up to four times as high as for taper roller bearings of series 313, 322 B, 323 B and T7FC, and up to eight times as high for spherical roller thrust bearings.

Power loss and bearing temperature

The power loss in a bearing as a result of bearing friction can be obtained using the equation

$$N_R = 1,05 \times 10^{-4} M n$$

where

N_R = power loss, W

M = total frictional moment of the bearing, Nmm

n = rotational speed, r/min

If the cooling factor (the heat to be removed from the bearing per degree of temperature difference between bearing and ambient) is known, a rough estimate of the temperature increase in the bearing can be obtained using

$$\Delta T = N_R / W_s$$

where

ΔT = temperature increase, °C

N_R = power loss, W

W_s = cooling factor, W/°C

Calculation example

A spherical roller bearing 22208 E is to operate at a speed of 3 500 r/min under the following operating conditions:

Actual radial bearing load $F_r = 2\,990\text{ N}$

Actual axial bearing load $F_a = 100\text{ N}$

Inner ring rotation

Operating temperature $+40\text{ °C}$

Oil bath lubrication

Oil level $H = 2,5\text{ mm}$ above the edge of the outer ring raceway under static conditions. Mineral oil having a kinematic viscosity $\nu = 68\text{ mm}^2/\text{s}$ at 40 °C

Requirement:

What will be the total frictional moment?

1. Calculation of the geometry and load dependent variables

According to **table 2a** on **page 91** with bearing mean diameter

$$d_m = 0,5 (d + D) = 0,5 (40 + 80) = 60\text{ mm}$$

- Rolling friction variables

$$\begin{aligned} G_{rr,e} &= R_1 d_m^{1,85} (F_r + R_2 F_a)^{0,54} \\ &= 1,6 \times 10^{-6} \times 60^{1,85} \times \\ &\quad (2\,990 + 5,84 \times 100)^{0,54} \\ &= 0,26 \end{aligned}$$

$$\begin{aligned} G_{rr,l} &= R_3 d_m^{2,3} (F_r + R_4 F_a)^{0,31} \\ &= 2,81 \times 10^{-6} \times 60^{2,3} \times \\ &\quad (2\,990 + 5,8 \times 100)^{0,31} \\ &= 0,436 \end{aligned}$$

since $G_{rr,e} < G_{rr,l}$, then

$$G_{rr} = 0,26$$

- Sliding friction variables

$$\begin{aligned} G_{sl,e} &= S_1 d_m^{0,25} (F_r^4 + S_2 F_a^4)^{1/3} \\ &= 3,62 \times 10^{-3} \times 60^{0,25} \times \\ &\quad (2\,990^4 + 508 \times 100^4)^{1/3} \\ &= 434 \end{aligned}$$

$$\begin{aligned} G_{sl,l} &= S_3 d_m^{0,94} (F_r^3 + S_4 F_a^3)^{1/3} \\ &= 8,8 \times 10^{-3} \times 60^{0,94} \times \\ &\quad (2\,990^3 + 117 \times 100^3)^{1/3} \\ &= 1\,236,6 \end{aligned}$$

since $G_{sl,e} < G_{sl,l}$, then

$$G_{sl} = 434$$

2. Calculation of the rolling frictional moment

$$\begin{aligned} M_{rr} &= G_{rr} (\nu n)^{0,6} = 0,26 \times (68 \times 3\,500)^{0,6} \\ &= 437\text{ Nmm} \end{aligned}$$

3. Calculation of the sliding frictional moment

Assuming full film conditions, $\kappa > 2$

$$M_{sl} = \mu_{sl} G_{sl} = 0,05 \times 434 = 21,7\text{ Nmm}$$

4. Calculation of the inlet shear heating reduction factor

$$\begin{aligned} \Phi_{ish} &= \frac{1}{1 + 1,84 \times 10^{-9} \times (n \times d_m)^{1,28} \nu^{0,64}} \\ &= \frac{1}{1 + 1,84 \times 10^{-9} \times (3\,500 \times 60)^{1,28} 68^{0,64}} \\ &\approx 0,85 \end{aligned}$$

5. Calculation of kinematic replenishment/starvation reduction factor for oil bath lubrication

$$\begin{aligned}\phi_{rs} &= \frac{1}{e^{K_{rs} v n (d+D)} \sqrt{\frac{K_z}{2(D-d)}}} \\ &= \frac{1}{2,718^{3 \times 10^{-8} \times 68 \times 3\,500 \times (40+80)} \sqrt{\frac{5,5}{2 \times (80-40)}}} \\ &\approx 0,8\end{aligned}$$

6. Calculation of the drag losses in oil bath lubrication

With a drag loss variable as function of

$$H/d_m = 2,5/60 = 0,041$$

from the **diagram 2** on **page 99**, it can be seen that drag losses are small, since $H/d_m < 0,1$. However, they can still be taken into account. For roller bearings the drag loss variable V_M becomes approximately $0,3 \times 10^{-4}$.

Then the roller bearing related constant can be obtained from

$$\begin{aligned}K_{roll} &= \frac{K_L K_z (d+D)}{D-d} \times 10^{-12} \\ &= \frac{0,8 \times 5,5 \times (40+80)}{80-40} \times 10^{-12} \\ &= 13,2 \times 10^{-12}\end{aligned}$$

The drag losses can then be obtained, as an approximation, from

$$\begin{aligned}M_{drag} &= 10 V_M K_{roll} B d_m^4 n^2 \\ &= 10 \times 0,3 \times 10^{-4} \times \\ &\quad 13,2 \times 10^{-12} \times 23 \times 604 \times 3\,500^2 \\ &= 14,5 \text{ Nmm}\end{aligned}$$

7. Calculation of the total frictional moment of 22208 E according to the new SKF model

$$\begin{aligned}M &= \phi_{ish} \phi_{rs} M_{rr} + M_{sl} + M_{drag} \\ &= 0,85 \times 0,8 \times 437 + 21,7 + 14,5 \\ &= 334 \text{ Nmm}\end{aligned}$$

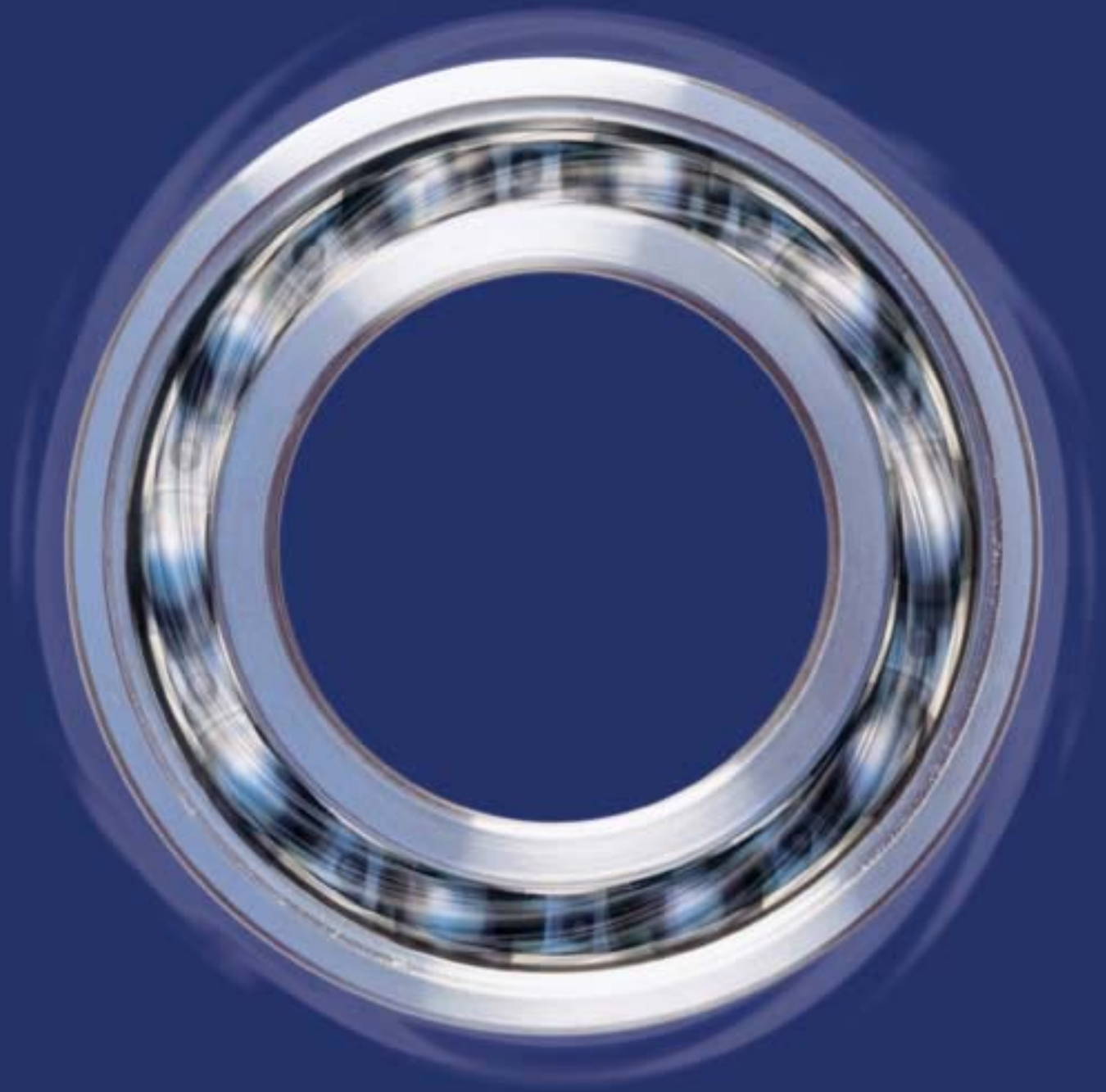

Speeds and vibration

Reference speeds	108
Influence of load and oil viscosity on reference speed/permissible speed.....	108
Speeds above the reference speed.....	109
Limiting speeds.....	114
Special cases	114
Low speeds	114
Oscillating movements.....	114
Vibration generation in a bearing	115
Excitation due to varying numbers of loaded rolling elements.....	115
Accuracy of associated components.....	115
Local damage.....	115
Contaminants	115
Influence of the bearing on the vibration behaviour of the application	115

Speeds and vibration

There is a limit to the speed at which rolling bearings can be operated. Generally, it is the operating temperature for the lubricant being used or the material of the bearing components that sets the limit.

The speed at which limiting operating temperature is reached depends on the frictional heat generated in the bearing (including any externally applied heat) and the amount of heat that can be transported away from the bearing.

Bearing type and size, internal design, load, lubrication and cooling conditions as well as cage design, accuracy and internal clearance all play a part in determining speed capability.

In the product tables generally two speeds are listed: (thermal) reference speed and (kinematical) limiting speed, the value of which depending on what criteria are considered.

Reference speeds

The (thermal) reference speed listed in the product tables represent a reference value that is to be used to determine the permissible operational speed of the bearing subjected to a certain load and running with a certain lubricant viscosity.

The values of the reference speed listed are in according with ISO 15312:2003 (where thrust ball bearings are excluded). This ISO standard has been established for oil lubrication, but is also valid for grease lubrication.

The reference speed for a given bearing represents the speed, under specified operating conditions, at which there is equilibrium between the heat that is generated by the bearing and the heat that is dissipated from the bearing to the shaft, housing and lubricant. The reference conditions according to ISO 15312:2003 for obtaining this heat balance are

- a temperature increase of 50 °C above an ambient temperature of 20 °C, i.e. a bearing temperature of 70 °C, measured on the bearing stationary outer ring or housing washer
- for a radial bearing: a constant radial load, being 5 % of the basic static load rating C_0
- for a thrust bearing: a constant axial load, being 2 % of the basic static load rating C_0
- open bearings with Normal clearance

for oil lubricated bearings:

- lubricant: mineral oil without EP additives having a kinematic viscosity at 70 °C of:
 $\nu = 12 \text{ mm}^2/\text{s}$ (ISO VG 32) for radial bearings,
 $\nu = 24 \text{ mm}^2/\text{s}$ (ISO VG 68) for thrust roller bearings
- method of lubrication: oil bath with the oil reaching up to the middle of the rolling element in the lowest position

for grease lubricated bearings:

- lubricant: regular grease with a lithium thickener and a mineral base oil having a viscosity of 100 to 200 mm^2/s at 40 °C (e.g. ISO VG 150)
- grease quantity: approximately 30 % of the free space in the bearing.

A temperature peak may occur during initial start-up of a grease-lubricated bearing. Therefore the bearing may have to be in operation for up to 10 to 20 hours before it reaches normal operating temperature.

Under these specific conditions the reference speed for oil and grease-lubrication will be equal.

It may be necessary to reduce the ratings in applications where the outer ring rotates.

For certain bearings, where the speed limit is not determined by heat from the rolling element/raceway contacts, only limiting speeds are shown in the bearing tables. These include, for example, bearings with contact seals.

Influence of load and oil viscosity on reference speed/permissible speed

When load and viscosity values higher than the reference values are applied, the frictional resistance will increase so that a bearing cannot operate at the suggested reference speed, unless higher temperatures can be permitted. Lower viscosity values may result in higher operational speeds.

The influence of load and kinematic viscosity on the reference speed can be obtained from the diagrams:

Diagram 1: Radial ball bearings, **page 110.**

Diagram 2: Radial roller bearings, **page 111.**

Diagram 3: Thrust ball bearings, **page 112.**

Diagram 4: Thrust roller bearings, **page 113.**

Oil lubrication

Values of the adjustment factors for oil lubrication

- f_p : for the influence of the equivalent dynamic bearing load P and
- f_v : for the influence of viscosity

can be obtained from **diagrams 1 to 4** as a function of P/C_0 and the bearing mean diameter d_m

where

P = equivalent dynamic bearing load, kN

C_0 = basic static load rating, kN

d_m = bearing mean diameter
= $0,5 (d + D)$, mm

The viscosity values in the diagrams are expressed with ISO designations, for example, ISO VG 32, where 32 is the oil viscosity at 40 °C.

If the reference temperature of 70 °C is to remain unchanged, the permissible speed is obtained from

$$n_{\text{perm}} = n_r f_p f_v$$

where

n_{perm} = permissible rotational speed, r/min

n_r = reference speed, r/min

f_p = adjustment factor for bearing load P

f_v = adjustment factor for oil viscosity

Grease lubrication

The diagrams are also valid for grease lubrication. However, the reference speed for grease lubrication is based on a base oil viscosity VG 150, but can also be used for the viscosity range ISO VG 100 – ISO VG 200. For other viscosities, the value of f_v needs to be calculated as f_v for the base oil viscosity at 40 °C of the selected grease, divided by f_v for an ISO VG 150 oil, i.e.

$$n_{\text{perm}} = n_r f_p \frac{f_v \text{ actual base oil viscosity}}{f_v \text{ base oil viscosity ISO VG150}}$$

Example 1

An SKF Explorer 6210 deep groove ball bearing is subjected to a load $P = 0,24 C_0$ and has an oil bath lubrication with oil viscosity 68 mm²/s at 40 °C. Which reference speed can be expected?

For bearing 6210: $d_m = 0,5 (50 + 90) = 70$ mm. From **diagram 1, page 110**, with $d_m = 70$ mm and $P/C_0 = 0,24$, $f_p = 0,63$ and with $P/C_0 = 0,24$ and ISO VG 68, $f_v = 0,85$.

The permissible bearing speed for which an operating temperature of 70 °C can be expected, n_{perm} , will then be

$$n_{\text{perm}} = 15\,000 \times 0,63 \times 0,85 = 8\,030 \text{ r/min}$$

Example 2

An SKF Explorer 22222 E spherical roller bearing is subjected to a load $P = 0,15 C_0$ and is grease lubricated having a base oil viscosity 220 mm²/s at 40 °C. Which reference speed can be expected?

For bearing 22222 E: $d_m = 0,5 (110 + 200) = 155$ mm. From **diagram 2, page 111**, with $d_m = 155$ mm and $P/C_0 = 0,15$, $f_p = 0,53$ and with $P/C_0 = 0,15$ and ISO VG 220, $f_v \text{ actual} = 0,83$; with $P/C_0 = 0,15$ and ISO VG 150, $f_v \text{ ISO VG150} = 0,87$.

The permissible bearing speed for which an operating temperature of 70 °C can be expected, n_{perm} , will then be

$$n_{\text{perm}} = 3\,000 \times 0,53 \times 0,83 / 0,87 = 1\,520 \text{ r/min}$$

Speeds above the reference speed

It is possible to operate bearings at speeds above the reference speed if the friction within the bearing can be reduced via a lubrication system that applies accurately measured small quantities of lubricant, or by removing heat either by a circulating oil lubrication system, by cooling ribs on the housing, or by directing cooling air streams (→ section “Methods of oil lubrication”, starting on **page 248**).

Any increase in speed above the reference speed without taking any of these precautions could cause bearing temperatures to rise excessively. An increase in bearing temperature means that lubricant viscosity is lowered and film formation is made more difficult, leading to even higher friction and further temperature increases. If, at the same time, the operational clearance in the bearing is reduced because of increased inner ring temperature, the final consequence would be bearing seizure. Any increase in speed above the reference speed generally means that the temperature difference between inner and outer rings is greater than normal.

Adjustment factors f_p and f_v for radial ball bearings

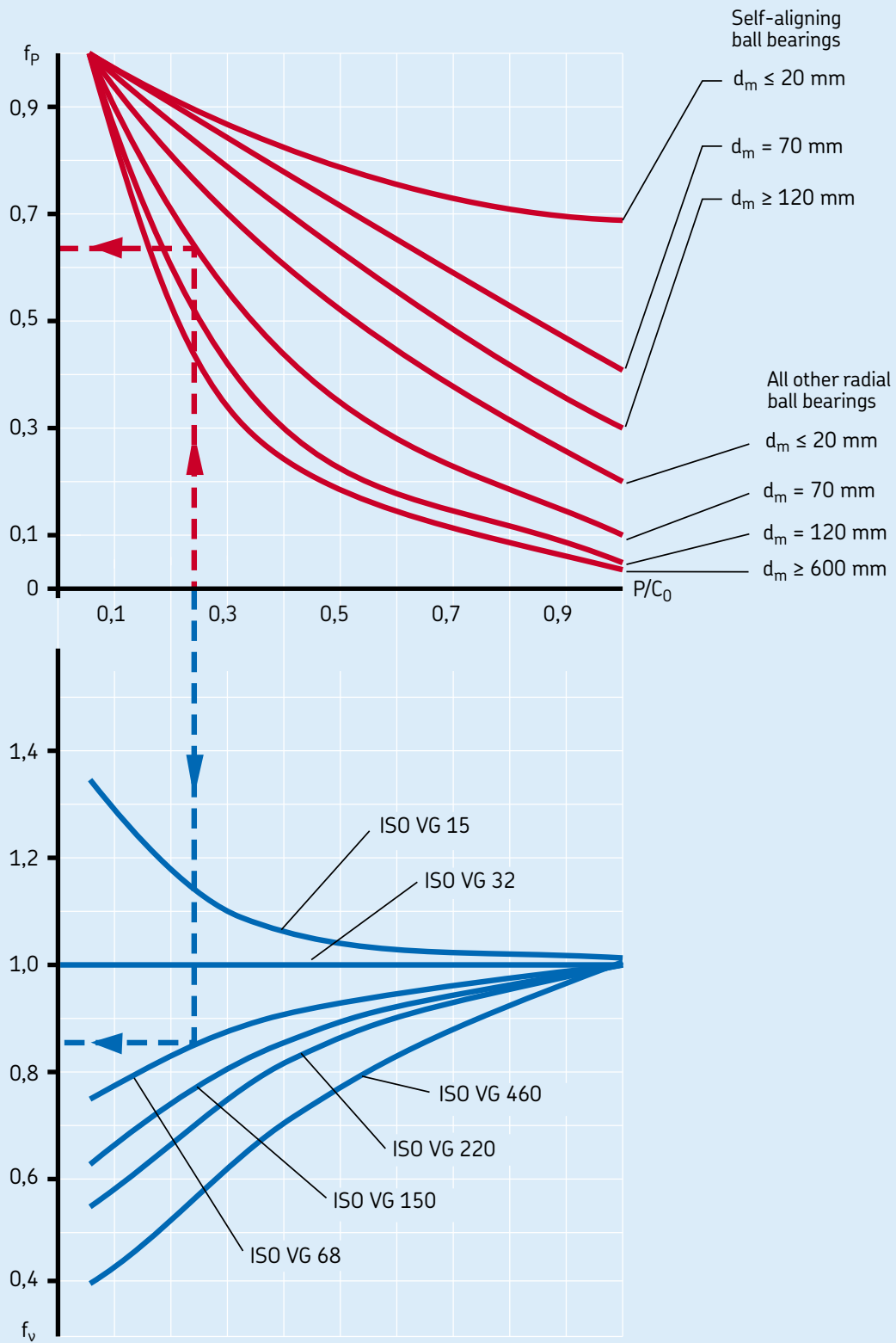

Adjustment factors f_p and f_v for radial roller bearings

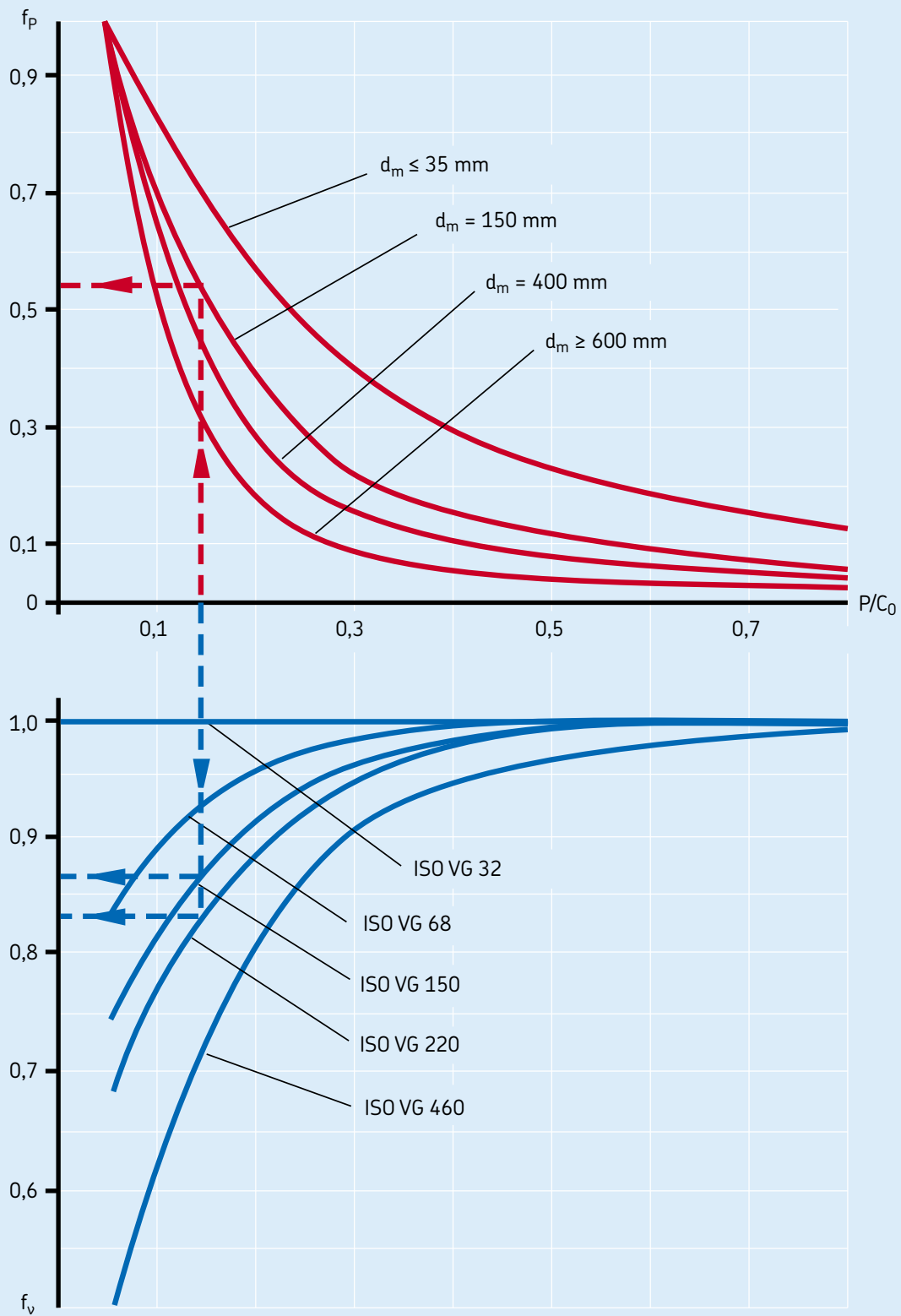

Adjustment factors f_p and f_v for thrust ball bearings

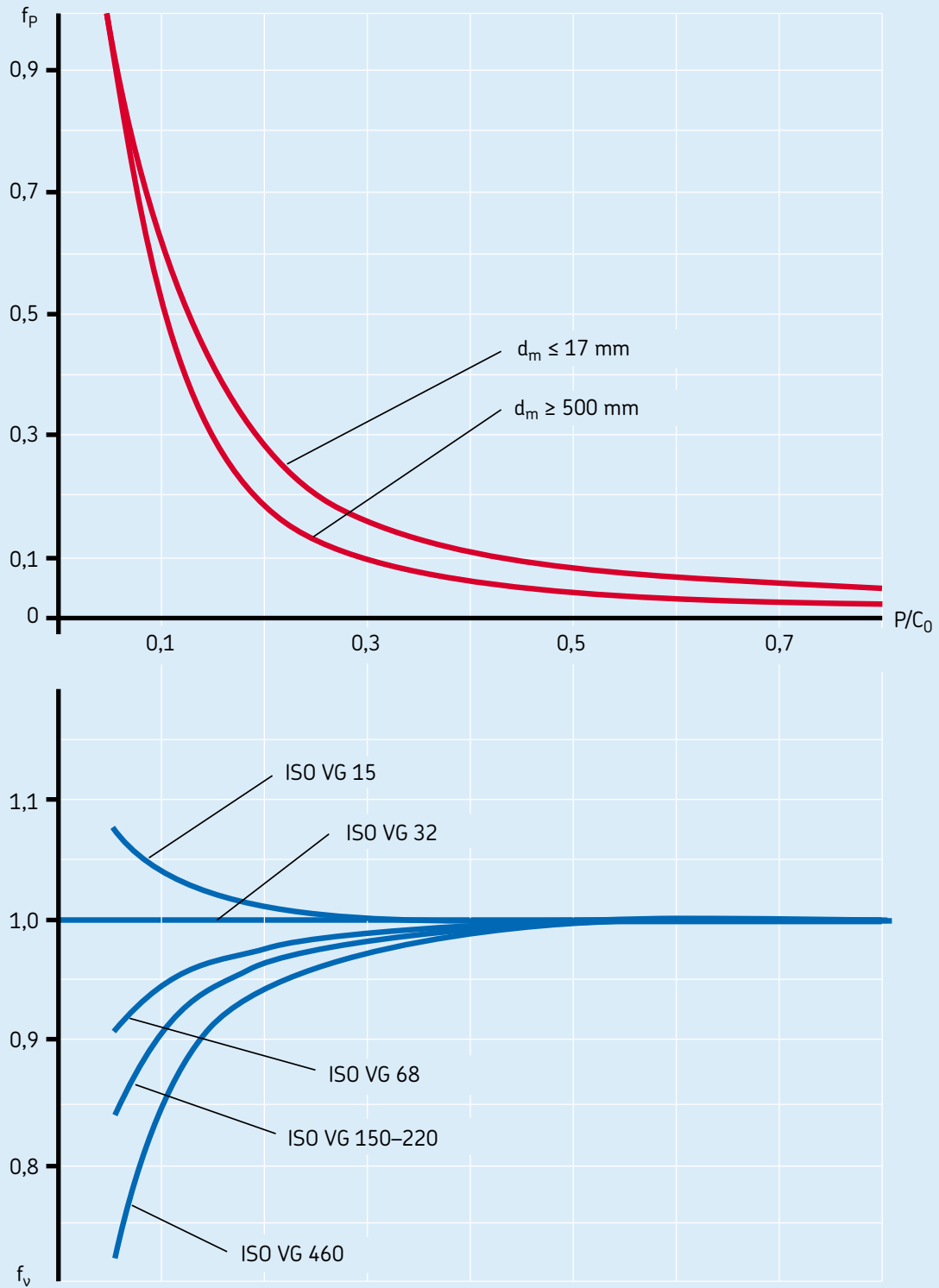

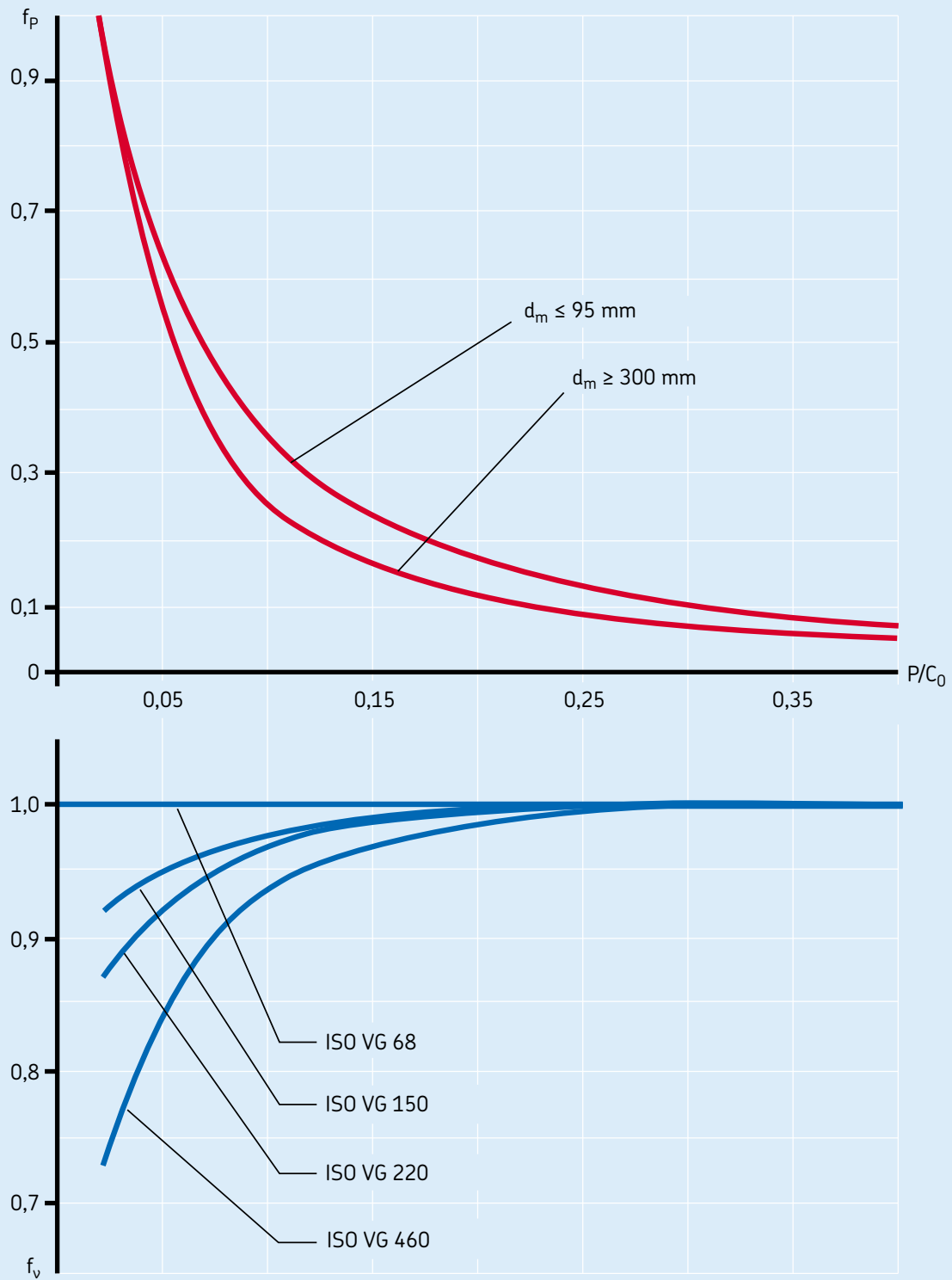
Adjustment factors f_p and f_v for thrust roller bearings

Speeds and vibration

Usually, therefore, a bearing with a C3 internal clearance, which is greater than Normal, is required, and it may be necessary to look more closely at the temperature distribution in the bearing.

Limiting speeds

The limiting speed is determined by criteria that include the form stability or strength of the cage, lubrication of cage guiding surfaces, centrifugal and gyratory forces acting on the rolling elements, precision and other speed-limiting factors, such as seals and lubricant for sealed bearings.

Experience gained from laboratory tests and practical applications indicates that there are maximum speeds that should not be exceeded for technical reasons or because of the very high costs involved to keep the operating temperature at an acceptable level.

The limiting speeds shown in the bearing tables are valid for the bearing design and standard cage execution shown.

To run bearings at higher speeds than those shown in the tables some of the speed-limiting factors need to be improved, such as the running accuracy, cage material and design, lubrication and heat dissipation. It is therefore advisable to contact the SKF application engineering service.

For grease lubrication additional aspects should be considered such as lubrication of the cage guiding surfaces and the shear strength of the lubricant, which are determined by the base oil and thickener (→ section “Grease lubrication”, starting on **page 231**).

Some open ball bearings have very low friction and reference speeds listed might be higher than the limiting speeds. Therefore, the permissible speed needs to be calculated and be compared to the limiting speed. The lower of the two values should be retained.

It should be remembered that if bearings are to function satisfactorily, at high speeds, they must be subjected to a given minimum load. Details can be found in the introductory texts of the product tables under the heading “Minimum load”.

Special cases

In certain applications the speed limits are superseded in importance by other considerations.

Low speeds

At very low speeds it is impossible for an elasto-hydrodynamic lubricant film to be built up in the contacts between the rolling elements and raceways. In these applications, lubricants containing EP additives should generally be used (→ section “Grease lubrication”, starting on **page 231**).

Oscillating movements

With this type of movement the direction of rotation changes before the bearing has completed a single revolution. As the rotational speed is zero at the point where the direction of rotation is reversed, a full hydrodynamic film of lubricant cannot be maintained. In these cases it is important to use a lubricant containing an effective EP additive in order to obtain a boundary lubrication film that is able to support loads.

It is not possible to give a limit or a rating for the speed of such oscillating movements as the upper limit is not dictated by a heat balance but by the inertia forces that come into play. With each reversal of direction, there is a danger that inertia will cause the rolling elements to slide for a short distance and smear the raceways. The permissible accelerations and decelerations depend on the mass of the rolling elements and cage, the type and quantity of lubricant, the operational clearance and the bearing load. For connecting rod bearing arrangements, for example, preloaded bearings incorporating relatively small rolling elements with a small mass are used. General guidelines cannot be provided and it is necessary to analyse the movements more precisely in individual cases. It is advisable to contact the SKF application engineering service.

Vibration generation in a bearing

In general a rolling bearing does not generate noise by itself. What is perceived as “bearing noise” is in fact the audible effect of the vibrations generated directly or indirectly by the bearing on the surrounding structure. This is the reason why most of the time noise problems can be considered as vibration problems involving the complete bearing application.

Excitation due to varying numbers of loaded rolling elements

When a radial load is applied to a bearing, the number of rolling elements carrying the load varies slightly during operation, i.e. 2-3-2-3... This generates a displacement in the direction of the load. The resulting vibration cannot be avoided, but can be reduced by applying an axial preload to load all the rolling elements (not possible with cylindrical roller bearings).

Accuracy of associated components

In cases where there is a tight fit between the bearing ring and the housing or the shaft, the bearing ring may take the shape of the adjacent component. If form deviations are present, these may cause vibrations during operation. It is therefore important to machine the shaft and housing seating to the required tolerances (→ section “Tolerances for cylindrical form” on page 194).

Local damage

Due to mishandling or incorrect mounting, small sections on the raceways and rolling elements can be damaged. During operation, overrolling a damaged bearing component generates a specific vibration frequency. Frequency analysis of the vibrations can identify which bearing component suffered damage. This principle is used in SKF Condition Monitoring equipment to detect bearing damage.

To calculate SKF bearing frequencies please refer to the section “Calculations” in the “SKF Interactive Engineering Catalogue” on CD-ROM or online at www.skf.com, or contact the SKF application engineering service.

Contaminants

If operating in contaminated conditions, dirt particles may enter the bearing and be overrolled by the rolling elements. The generated vibration level is dependent on the amount, the size and the composition of the overrolled contaminant particles. No typical frequency pattern is generated. However, an audible and disturbing noise may be created.

Influence of the bearing on the vibration behaviour of the application

In many applications bearing stiffness is of the same order as the stiffness of the surrounding structure. This opens the possibility to reduce vibrations of the application by properly choosing the bearing (including preload and clearance) and its arrangement in the application. There are three ways to reduce vibration:

- Remove the critical excitation vibration from the application.
- Dampen the critical excitation vibration between excitant component and resonant components.
- Change the stiffness of the structure to change the critical frequency.

SKF

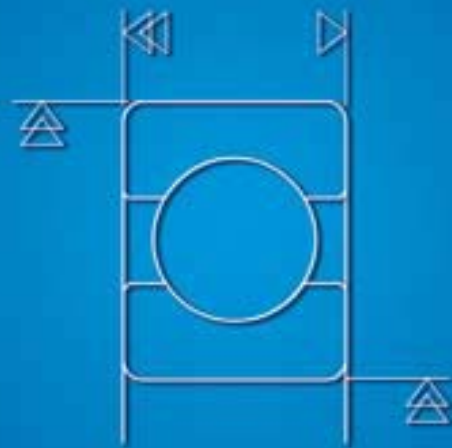
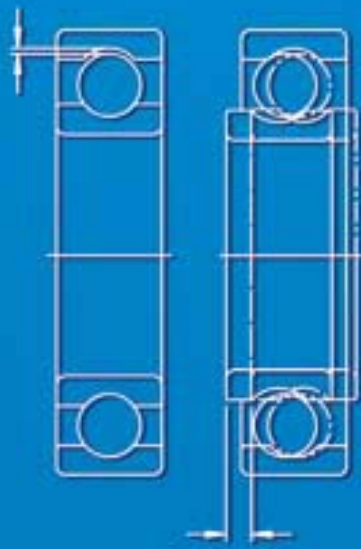
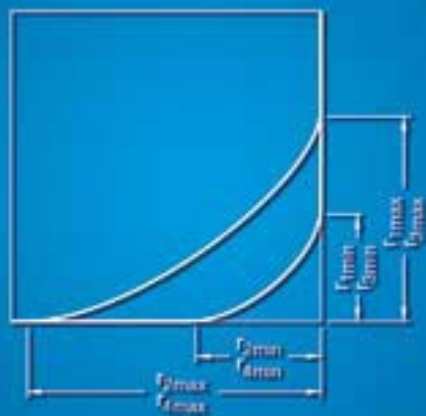

Bearing data – general

Dimensions	118
ISO General Plans.....	118
General Plans for inch bearings.....	119
Chamfer dimensions	119
Tolerances	120
Tolerance symbols.....	120
Diameter Series identification	120
Tolerance tables.....	120
Limits for chamfer dimensions	121
Bearing internal clearance	137
Materials for rolling bearings	138
Materials for bearing rings and rolling elements.....	138
Cage materials.....	140
Seal materials.....	142
Safety precautions for fluoro rubber	143
Coatings	143
Cages	144
Pressed cages	144
Solid cages.....	145
Pin-type cages.....	146
Materials	146
Designations	147
Basic designations.....	148
Supplementary designations.....	151

Dimensions

Manufacturers and users of rolling bearings are, for reasons of price, quality and ease of replacement, only interested in a limited number of bearing sizes. The International Organization for Standardization (ISO) has therefore laid down General Plans for the boundary dimensions of

- metric radial rolling bearings in standard ISO 15:1998, except taper roller bearings
- metric radial taper roller bearings in standard ISO 355:1977
- metric thrust rolling bearings in standard ISO 104: 2002.

ISO General Plans

The ISO General Plans for boundary dimensions of radial bearings contain a progressive series of standardized outside diameters for every standard bore diameter arranged in Diameter Series 7, 8, 9, 0, 1, 2, 3 and 4 (in order of increasing outside diameter). Within each Diameter Series different Width Series have also been established (Width Series 8, 0, 1, 2, 3, 4, 5, 6 and 7 in order of increasing width). The Width Series for radial bearings corresponds to the Height Series for thrust bearings (Height Series 7, 9, 1 and 2 in order of increasing height).

By combining a Width or Height Series with a Diameter Series, a Dimension Series, designated by two figures, is arrived at. The first figure identifies the Width or Height Series and the second the Diameter Series (→ **fig. 1**).

In the ISO General Plan for single row metric taper roller bearings, the boundary dimensions are grouped for certain ranges of the contact angle α , known as the Angle Series (Angle Series 2, 3, 4, 5, 6 and 7 in order of increasing angle). Based on the relationship between the outside and bore diameters, and between the total bearing width and the cross-sectional height, Diameter and Width Series have also been established. Here, a Dimension Series is obtained by combining the Angle Series with a Diameter and a Width Series (→ **fig. 2**). These Dimension Series consist of one figure for the Angle Series and two letters, where the first letter identifies the Diameter Series and the second the Width Series.

With a very few exceptions, dictated by rolling bearing development, the bearings in this catalogue comply with the ISO General Plans or with other ISO standards for the dimensions of some bearing types for which the ISO Dimension Series are inappropriate. Interchangeability is therefore guaranteed. Additional information is provided under the heading “Dimensions” in the introductory texts to the individual product sections.

Experience has shown that the requirements of the vast majority of bearing applications can be met using bearings with these standardized dimensions.

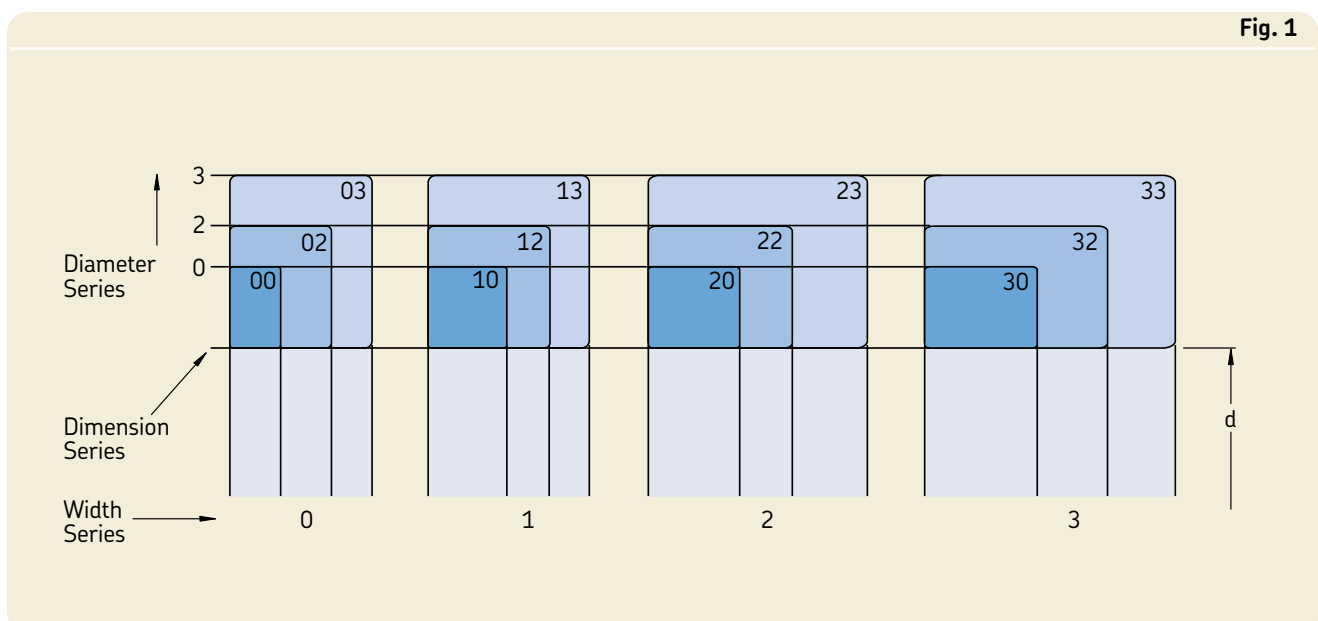

General Plans for inch bearings

A large group of bearings in inch sizes are inch taper roller bearings. The dimensions of these bearings conform to AFBMA Standard 19-1974 (ANSI B3.19-1975). ANSI/ABMA Standard 19.2-1994 has subsequently replaced this standard, but this later standard no longer includes dimensions.

In addition to the inch taper roller bearings, some inch ball bearings and cylindrical roller bearings that follow the earlier British Standard BS 292-2:1982, are also available, but not shown in this catalogue. This standard has subsequently been withdrawn as a consequence of metrication and it is not recommended that these bearings be used for new designs.

Chamfer dimensions

Minimum values for the chamfer dimensions (→ **fig. 3**) in the radial direction (r_1, r_3) and the axial direction (r_2, r_4) are provided in the product tables. These values are in accordance with the General Plans listed in the Standards

- ISO 15:1998, ISO 12043:1995 and ISO 12044:1995 for radial rolling bearings
- ISO 355:1977 for radial taper roller bearings
- ISO 104: 2002 for thrust rolling bearings.

The appropriate maximum chamfer limits, that are important when dimensioning fillet radii are in accordance with the Standard ISO 582:1995 and can be found in the section “Tolerances”, starting on **page 120**.

Fig. 3

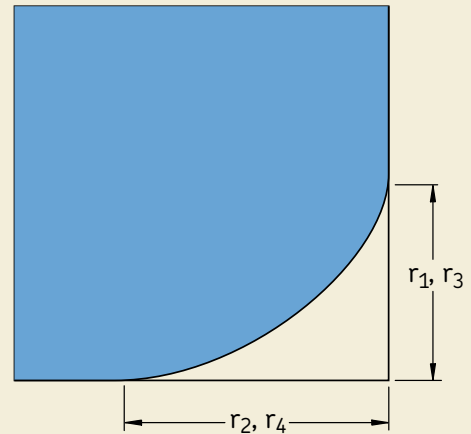
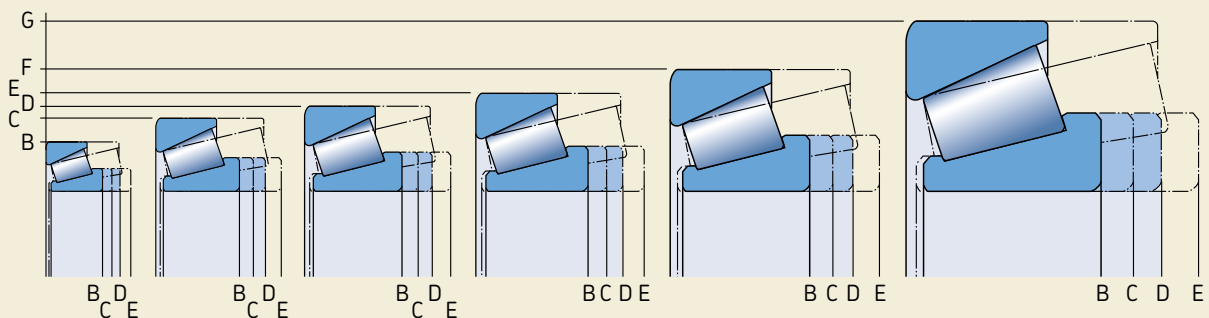

Fig. 2



Tolerances

The dimensional and running accuracy of rolling bearings has been standardized internationally. In addition to the Normal tolerances, the ISO standards also cover closer tolerances, e.g.

- tolerance class 6 which corresponds to SKF tolerance class P6
- tolerance class 5 which corresponds to SKF tolerance class P5.

For special applications, such as machine tool spindles, SKF also manufactures bearings with higher accuracy, e.g. to tolerance classes P4, P4A, PA9A, SP and UP. For additional information please refer to the SKF catalogue “High-precision bearings”.

Tolerance information about each bearing type is contained in the introductory texts to the various product table sections under the heading “Tolerances”. Bearings with higher accuracy than Normal are identified by a designation suffix for the tolerance class (→ section “Supplementary designations”, starting on **page 151**).

Tolerance symbols

The tolerance symbols used in the tolerance **tables 3 to 12** are listed together with their definitions in **table 1** on **pages 122 and 123**.

Diameter Series identification

As the tolerances for the bore and outside diameter variation V_{dp} and V_{Dp} quoted in the tables for metric rolling bearings (except taper roller bearings) are not universally valid for all Diameter Series, and it is not always possible to immediately identify the ISO Diameter Series to which a bearing belongs from its designation, this information is provided in **table 2** on **page 124**.

Tolerance tables

The actual tolerances are provided in the tables referenced in the following.

Table 3: Normal tolerances for radial bearings, except taper roller bearings

Table 4: Class P6 tolerances for radial bearings, except taper roller bearings

Table 5: Class P5 tolerances for radial bearings, except taper roller bearings

Table 6: Normal and class CL7C tolerances for metric taper roller bearings

Table 7: Class CLN tolerances for metric taper roller bearings

Table 8: Class P5 tolerances for metric taper roller bearings

Table 9: Tolerances for inch taper roller bearings

Table 10: Tolerances for thrust bearings

Table 11: Normal, P6 and P5 class tolerances for tapered bore, taper 1:12

Table 12: Normal tolerances for tapered bore, taper 1:30

Where standardized, the values comply with ISO 492:2002, ISO 199:1997 and ANSI/ABMA Std 19.2:1994.

Limits for chamfer dimensions

To prevent the improper dimensioning of fillets on associated components for rolling bearings and to facilitate the calculation of retaining ring location arrangements, the maximum chamfer limits for the relevant minimum chamfer dimensions (→ **fig. 4**) provided in the product tables can be found in

Table 13: Chamfer dimension limits for metric radial and thrust bearings, except taper roller bearings

Table 14: Chamfer dimension limits for metric radial taper roller bearings

Table 15: Chamfer dimension limits for inch taper roller bearings

starting on **page 135**. These limits for metric bearings conform to ISO 582:1995. The chamfer dimension limits for inch taper roller bearings, which differ considerably from those for metric bearings, conform to ANSI/ABMA 19.2-1994.

The symbols used in the **tables 13 to 15** are listed together with their definitions in **table 1** on **pages 122 and 123**.

Example

Which is the largest radial value ($r_{1\max}$) for the chamfer of deep groove ball bearing 6211?

From the product table on **page 309** $r_{1\min} = 1,5$ mm and $d = 55$ mm are obtained. **Table 13** on **page 135** with $r_{s\min} = 1,5$ mm and d smaller than 120 mm then gives $r_{1\max} = 2,3$ mm.

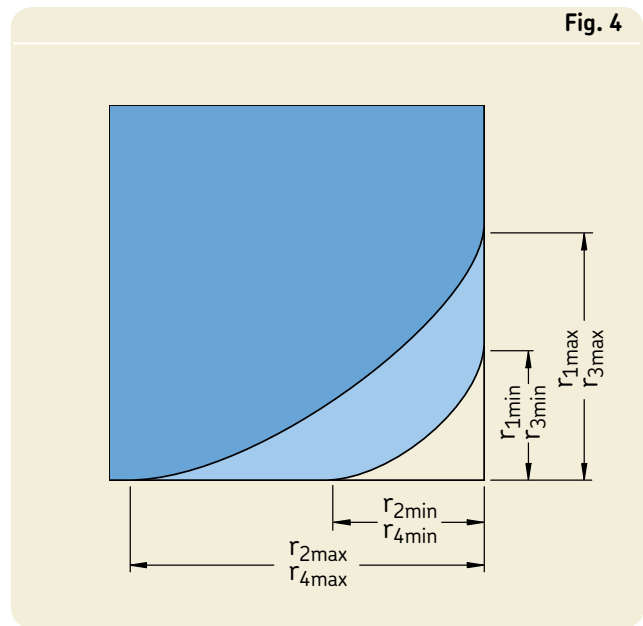

Table 1

Tolerance symbols	
Tolerance symbol	Definition
Bore diameter	
d	Nominal bore diameter
d_s	Single bore diameter
d_{mp}	1. Mean bore diameter; arithmetical mean of the largest and smallest single bore diameters in one plane 2. Mean diameter at the small end of a tapered bore; arithmetical mean of the largest and smallest single diameters
Δ_{ds}	Deviation of a single bore diameter from the nominal ($\Delta_{ds} = d_s - d$)
Δ_{dmp}	Deviation of the mean bore diameter from the nominal ($\Delta_{dmp} = d_{mp} - d$)
V_{dp}	Bore diameter variation; difference between the largest and smallest single bore diameters in one plane
V_{dmp}	Mean bore diameter variation; difference between the largest and smallest mean bore diameter
d₁	Nominal diameter at theoretical large end of a tapered bore
d_{1mp}	Mean diameter at theoretical large end of tapered bore; arithmetical mean of the largest and smallest single bore diameters
Δ_{d1mp}	Deviation of the mean bore diameter at the theoretical large end of a tapered bore from the nominal ($\Delta_{d1mp} = d_{1mp} - d_1$)
Outside diameter	
D	Nominal outside diameter
D_s	Single outside diameter
D_{mp}	Mean outside diameter; arithmetical mean of the largest and smallest single outside diameters in one plane
Δ_{Ds}	Deviation of a single outside diameter from the nominal ($\Delta_{Ds} = D_s - D$)
Δ_{Dmp}	Deviation of the mean outside diameter from the nominal ($\Delta_{Dmp} = D_{mp} - D$)
V_{Dp}	Outside diameter variation; difference between the largest and smallest single outside diameters in one plane
V_{Dmp}	Mean outside diameter variation; difference between the largest and smallest mean outside diameter
Chamfer limits	
r_s	Single chamfer dimension
r_{s min}	Smallest single chamfer dimension of r _s , r ₁ , r ₂ , r ₃ , r ₄ ...
r₁, r₃	Radial direction chamfer dimensions
r₂, r₄	Axial direction chamfer dimensions

Tolerance symbols	
Tolerance symbol	Definition
Width or height	
B, C	Nominal width of inner ring and outer ring, respectively
B_s, C_s	Single width of inner ring and outer ring, respectively
B_{1s}, C_{1s}	Single width of inner ring and outer ring, respectively, of a bearing specifically manufactured for paired mounting
Δ_{Bs}, Δ_{Cs}	Deviation of single inner ring width or single outer ring width from the nominal ($\Delta_{Bs} = B_s - B$; $\Delta_{Cs} = C_s - C$; $\Delta_{B1s} = B_{1s} - B_1$; $\Delta_{C1s} = C_{1s} - C_1$)
V_{Bs}, V_{Cs}	Ring width variation; difference between the largest and smallest single widths of inner ring and of outer ring, respectively
T	1. Nominal width (abutment width) of taper roller bearing; distance between inner ring (cone) back face and outer ring (cup) back face 2. Nominal height (H) of single direction thrust bearing (except spherical roller thrust bearing, see T ₄)
T₁	1. Nominal width of taper roller bearing, cone assembled with master cup 2. Nominal height (H ₁) of single direction thrust ball bearing with seating washer
T₂	1. Nominal width of taper roller bearing, cup assembled with master cone 2. Nominal height (H) of double direction thrust bearing
T₃	Nominal height (H ₁) of double direction thrust ball bearing with seating washers
T₄	Nominal height (H) of spherical roller thrust bearing
Δ_{Ts}	1. Deviation of effective single width of taper roller bearing from the nominal 2. Deviation of height of single direction thrust bearing from the nominal (except spherical roller thrust bearing, see Δ _{T4s})
Δ_{T1s}	1. Deviation of effective single width of cone from the nominal 2. Deviation of height of single direction thrust ball bearing with seating washer from the nominal
Δ_{T2s}	1. Deviation of effective single width of cup from the nominal 2. Deviation of height of double direction thrust bearing from the nominal
Δ_{T3s}	Deviation of height of double direction thrust ball bearing with seating washers from the nominal
Δ_{T4s}	Deviation of height of spherical roller thrust bearing from the nominal
Running accuracy	
K_{ia}, K_{ea}	Radial runout of inner ring and outer ring, respectively, of assembled bearing
S_d	Side face runout with reference to bore (of inner ring)
S_D	Outside inclination variation; variation in inclination of outside cylindrical surface to outer ring side face
S_{ia}, S_{ea}	Axial runout of inner ring and outer ring, respectively, of assembled bearing
S_i, S_e	Thickness variation, measured from middle of raceway to back (seating) face of shaft washer and of housing washer, respectively (axial runout)

Bearing data – general

Table 2

Diameter Series (radial bearings)			
Bearing type	ISO Diameter Series 7, 8, 9	0, 1	2, 3, 4
Deep groove ball bearings ¹⁾	617, 618, 619 627, 628 637, 638, 639	60 160, 161 630	2, 3 42, 43 62, 63, 64, 622, 623
Angular contact ball bearings			32, 33 72, 73 QJ 2, QJ 3
Self-aligning ball bearings ²⁾	139	10, 130	12, 13, 112 22, 23
Cylindrical roller bearings		NU 10, 20 NJ 10	NU 2, 3, 4, 12, 22, 23 NJ 2, 3, 4, 22, 23 NUP 2, 3, 22, 23 N 2, 3
Full complement cylindrical roller bearings	NCF 18, 19, 28, 29 NNC 48, 49 NNCF 48, 49 NNCL 48, 49	NCF 30 NNF 50 NNCF 50	NCF 22 NJG 23
Spherical roller bearings	238, 239 248, 249	230, 231 240, 241	222, 232 213, 223
CARB toroidal roller bearings	C 39, 49, 59, 69	C 30, 31 C 40, 41	C 22, 23 C 32

¹⁾ Bearings 604, 607, 608, 609 belong to Diameter Series 0, bearings 623, 624, 625, 626, 627, 628 and 629 to Diameter Series 2, bearings 634, 635 and 638 to Diameter Series 3

²⁾ Bearing 108 belongs to Diameter Series 0, bearings 126, 127 and 129 to Diameter Series 2, bearing 135 to Diameter Series 3

Table 3

Normal tolerances for radial bearings, except taper roller bearings

Inner ring

d		$\Delta_{dmp}^{1)}$		V_{dp} Diameter Series			V_{dmp}	Δ_{Bs}		Δ_{B1s}		V_{Bs}	K_{ia}
over	incl.	high	low	7, 8, 9 max	0, 1 max	2, 3, 4 max	max	high	low	high	low	max	max
mm		μm		μm			μm	μm		μm		μm	μm
–	2,5	0	–8	10	8	6	6	0	–40	–	–	12	10
2,5	10	0	–8	10	8	6	6	0	–120	0	–250	15	10
10	18	0	–8	10	8	6	6	0	–120	0	–250	20	10
18	30	0	–10	13	10	8	8	0	–120	0	–250	20	13
30	50	0	–12	15	12	9	9	0	–120	0	–250	20	15
50	80	0	–15	19	19	11	11	0	–150	0	–380	25	20
80	120	0	–20	25	25	15	15	0	–200	0	–380	25	25
120	180	0	–25	31	31	19	19	0	–250	0	–500	30	30
180	250	0	–30	38	38	23	23	0	–300	0	–500	30	40
250	315	0	–35	44	44	26	26	0	–350	0	–500	35	50
315	400	0	–40	50	50	30	30	0	–400	0	–630	40	60
400	500	0	–45	56	56	34	34	0	–450	0	–630	50	65
500	630	0	–50	63	63	38	38	0	–500	0	–800	60	70
630	800	0	–75	–	–	–	–	0	–750	–	–	70	80
800	1 000	0	–100	–	–	–	–	0	–1 000	–	–	80	90
1 000	1 250	0	–125	–	–	–	–	0	–1 250	–	–	100	100
1 250	1 600	0	–160	–	–	–	–	0	–1 600	–	–	120	120
1 600	2 000	0	–200	–	–	–	–	0	–2 000	–	–	140	140

¹⁾Tolerances for tapered bores → tables 11 and 12 on pages 133 and 134

Outer ring

D		Δ_{Dmp}		$V_{Dp}^{1)}$ Diameter Series				$V_{Dmp}^{1)}$	$\Delta_{Cs}, \Delta_{C1s}, V_{Cs}$	K_{ea}
over	incl.	high	low	7, 8, 9 max	0, 1 max	2, 3, 4 max	Sealed bearings ²⁾ max	max	max	
mm		μm		μm				μm	μm	
2,5	18	0	–8	10	8	6	10	6	Values are identical to those for inner ring of same bearing	15
18	30	0	–9	12	9	7	12	7		15
30	50	0	–11	14	11	8	16	8		20
50	80	0	–13	16	13	10	20	10		25
80	120	0	–15	19	19	11	26	11		35
120	150	0	–18	23	23	14	30	14		40
150	180	0	–25	31	31	19	38	19		45
180	250	0	–30	38	38	23	–	23		50
250	315	0	–35	44	44	26	–	26		60
315	400	0	–40	50	50	30	–	30		70
400	500	0	–45	56	56	34	–	34		80
500	630	0	–50	63	63	38	–	38		100
630	800	0	–75	94	94	55	–	55		120
800	1 000	0	–100	125	125	75	–	75		140
1 000	1 250	0	–125	–	–	–	–	–		160
1 250	1 600	0	–160	–	–	–	–	–		190
1 600	2 000	0	–200	–	–	–	–	–		220
2 000	2 500	0	–250	–	–	–	–	–		250

¹⁾Applies before bearing is assembled and after removal of internal and/or external snap ring, if used

²⁾Applies only to bearings of Diameter Series 2, 3 and 4

Bearing data – general

Table 4

Class P6 tolerances for radial bearings, except taper roller bearings

Inner ring

d		$\Delta_{dmp}^{1)}$		V_{dp} Diameter Series			V_{dmp}	Δ_{Bs}		Δ_{B1s}		V_{Bs}	K_{ia}
over	incl.	high	low	7, 8, 9 max	0, 1 max	2, 3, 4 max	max	high	low	high	low	max	max
mm		μm		μm			μm	μm		μm		μm	μm
–	2,5	0	–7	9	7	5	5	0	–40	–	–	12	5
2,5	10	0	–7	9	7	5	5	0	–120	0	–250	15	6
10	18	0	–7	9	7	5	5	0	–120	0	–250	20	7
18	30	0	–8	10	8	6	6	0	–120	0	–250	20	8
30	50	0	–10	13	10	8	8	0	–120	0	–250	20	10
50	80	0	–12	15	15	9	9	0	–150	0	–380	25	10
80	120	0	–15	19	19	11	11	0	–200	0	–380	25	13
120	180	0	–18	23	23	14	14	0	–250	0	–500	30	18
180	250	0	–22	28	28	17	17	0	–300	0	–500	30	20
250	315	0	–25	31	31	19	19	0	–350	0	–500	35	25
315	400	0	–30	38	38	23	23	0	–400	0	–630	40	30
400	500	0	–35	44	44	26	26	0	–450	0	–630	45	35
500	630	0	–40	50	50	30	30	0	–500	0	–800	50	40
630	800	0	–50	–	–	–	–	0	–750	–	–	55	45
800	1 000	0	–60	–	–	–	–	0	–1 000	–	–	60	50
1 000	1 250	0	–75	–	–	–	–	0	–1 250	–	–	70	60
1 250	1 600	0	–90	–	–	–	–	0	–1 600	–	–	70	70
1 600	2 000	0	–115	–	–	–	–	0	–2 000	–	–	80	80

¹⁾Tolerances for tapered bores → table 11 on page 133

Outer ring

D		Δ_{Dmp}		V_D Diameter Series			Sealed bearings ²⁾	$V_{Dmp}^{1)}$	$\Delta_{Cs}, \Delta_{C1s}, V_{Cs}$	K_{ea}
over	incl.	high	low	7, 8, 9 max	0, 1 max	2, 3, 4 max	max	max	max	
mm		μm		μm			μm	μm	μm	
2,5	18	0	–7	9	7	5	9	5	Values are identical to those for inner ring of same bearing	8
18	30	0	–8	10	8	6	10	6		9
30	50	0	–9	11	9	7	13	7		10
50	80	0	–11	14	11	8	16	8		13
80	120	0	–13	16	16	10	20	10		18
120	150	0	–15	19	19	11	25	11		20
150	180	0	–18	23	23	14	30	14		23
180	250	0	–20	25	25	15	–	15		25
250	315	0	–25	31	31	19	–	19		30
315	400	0	–28	35	35	21	–	21		35
400	500	0	–33	41	41	25	–	25		40
500	630	0	–38	48	48	29	–	29		50
630	800	0	–45	56	56	34	–	34		60
800	1 000	0	–60	75	75	45	–	45		75
1 000	1 250	0	–75	–	–	–	–	–		85
1 250	1 600	0	–90	–	–	–	–	–		100
1 600	2 000	0	–115	–	–	–	–	–		100
2 000	2 500	0	–135	–	–	–	–	–		120

¹⁾Applies before bearing is assembled and after removal of internal and/or external snap ring, if used

²⁾Applies only to bearings of Diameter Series 0, 1, 2, 3 and 4

Table 5

Class P5 tolerances for radial bearings, except taper roller bearings

Inner ring

d		Δ_{dmp}		V_{dp} Diameter Series 7, 8, 9 max		V_{dmp} max	Δ_{Bs}		Δ_{B1s}		V_{Bs} max	K_{ia} max	S_d max	$S_{ia}^{1)}$ max
over	incl.	high	low	max	0, 1, 2, 3, 4 max	max	high	low	high	low	max	max	max	max
mm		μm		μm		μm	μm		μm		μm	μm	μm	μm
-	2,5	0	-5	5	4	3	0	-40	0	-250	5	4	7	7
2,5	10	0	-5	5	4	3	0	-40	0	-250	5	4	7	7
10	18	0	-5	5	4	3	0	-80	0	-250	5	4	7	7
18	30	0	-6	6	5	3	0	-120	0	-250	5	4	8	8
30	50	0	-8	8	6	4	0	-120	0	-250	5	5	8	8
50	80	0	-9	9	7	5	0	-150	0	-250	6	5	8	8
80	120	0	-10	10	8	5	0	-200	0	-380	7	6	9	9
120	180	0	-13	13	10	7	0	-250	0	-380	8	8	10	10
180	250	0	-15	15	12	8	0	-300	0	-500	10	10	11	13
250	315	0	-18	18	14	9	0	-350	0	-500	13	13	13	15
315	400	0	-23	23	18	1	0	-400	0	-630	15	15	15	20
400	500	0	-28	28	21	1	0	-450	0	-630	18	17	18	23
500	630	0	-35	35	26	1	0	-500	0	-800	20	19	20	25
630	800	0	-45	-	-	-	0	-750	-	-	26	22	26	30
800	1 000	0	-60	-	-	-	0	-1 000	-	-	32	26	32	30
1 000	1 250	0	-75	-	-	-	0	-1 250	-	-	38	30	38	30
1 250	1 600	0	-90	-	-	-	0	-1 600	-	-	45	35	45	30
1 600	2 000	0	-115	-	-	-	0	-2 000	-	-	55	40	55	30

¹⁾Applies only to deep groove and angular contact ball bearings

Outer ring

D		Δ_{Dmp}		$V_{Dp}^{1)}$ Diameter Series 7,8,9 max		V_{Dmp} max	$\Delta_{Cs}, \Delta_{C1s}$	V_{Cs}	K_{ea}	S_D	$S_{ea}^{2)}$
over	incl.	high	low	max	0,1,2,3,4 max	max		max	max	max	max
mm		μm		μm		μm		μm	μm	μm	μm
2,5	18	0	-5	5	4	3	Values are identical to those for inner ring of same bearing	5	5	8	8
18	30	0	-6	6	5	3		5	6	8	8
30	50	0	-7	7	5	4		5	7	8	8
50	80	0	-9	9	7	5		6	8	8	10
80	120	0	-10	10	8	5		8	10	9	11
120	150	0	-11	11	8	6		8	11	10	13
150	180	0	-13	13	10	7		8	13	10	14
180	250	0	-15	15	11	8		10	15	11	15
250	315	0	-18	18	14	9		11	18	13	18
315	400	0	-20	20	15	10		13	20	13	20
400	500	0	-23	23	17	12	15	23	15	23	
500	630	0	-28	28	21	14	18	25	18	25	
630	800	0	-35	35	26	18	20	30	20	30	
800	1 000	0	-50	50	29	25	25	35	25	35	
1 000	1 250	0	-63	-	-	-	30	40	30	45	
1 250	1 600	0	-80	-	-	-	35	45	35	55	
1 600	2 000	0	-100	-	-	-	38	55	40	55	
2 000	2 500	0	-125	-	-	-	45	65	50	55	

¹⁾ Does not apply to sealed or shielded bearings

²⁾ Applies only to deep groove and angular contact ball bearings

Bearing data – general

Table 6

Normal and class CL7C tolerances for metric taper roller bearings

Inner ring, bearing width and ring widths

d		Δ_{dmp}		V_{dp}	V_{dmp}	Δ_{Bs}		K_{ia} Tolerance classes		Δ_{Ts}		Δ_{T1s}		Δ_{T2s}	
over	incl.	high	low	max	max	high	low	Normal max	CL7C max	high	low	high	low	high	low
mm		μm		μm	μm	μm		μm		μm		μm		μm	
10	18	0	-12	12	9	0	-120	15	7	+200	0	+100	0	+100	0
18	30	0	-12	12	9	0	-120	18	8	+200	0	+100	0	+100	0
30	50	0	-12	12	9	0	-120	20	10	+200	0	+100	0	+100	0
50	80	0	-15	15	11	0	-150	25	10	+200	0	+100	0	+100	0
80	120	0	-20	20	15	0	-200	30	13	+200	-200	+100	-100	+100	-100
120	180	0	-25	25	19	0	-250	35	–	+350	-250	+150	-150	+200	-100
180	250	0	-30	30	23	0	-300	50	–	+350	-250	+150	-150	+200	-100
250	315	0	-35	35	26	0	-350	60	–	+350	-250	+150	-150	+200	-100
315	400	0	-40	40	30	0	-400	70	–	+400	-400	+200	-200	+200	-200

Outer ring

D		Δ_{Dmp}		V_{Dp}	V_{Dmp}	Δ_{Cs}	K_{ea} Tolerance classes	
over	incl.	high	low	max	max		Normal max	CL7C max
mm		μm		μm	μm		μm	
18	30	0	-12	12	9	Values are identical to those for inner ring of same bearing	18	9
30	50	0	-14	14	11		20	10
50	80	0	-16	16	12		25	13
80	120	0	-18	18	14		35	18
120	150	0	-20	20	15		40	20
150	180	0	-25	25	19	45	23	
180	250	0	-30	30	23	50	–	
250	315	0	-35	35	26	60	–	
315	400	0	-40	40	30	70	–	
400	500	0	-45	45	34	80	–	
500	630	0	-50	50	38	100	–	
630	800	0	-75	75	55	120	–	

Table 7

Class CLN tolerances for metric taper roller bearings

Inner ring, bearing width and ring widths

d		Δ_{dmp}		V_{dp}	V_{dmp}	Δ_{Bs}		Δ_{Cs}		K_{ia}	Δ_{Ts}		Δ_{T1s}		Δ_{T2s}	
over	incl.	high	low	max	max	high	low	high	low	max	high	low	high	low	high	low
mm		μm		μm	μm	μm		μm		μm	μm		μm		μm	
10	18	0	-12	12	9	0	-50	0	-100	15	+100	0	+50	0	+50	0
18	30	0	-12	12	9	0	-50	0	-100	18	+100	0	+50	0	+50	0
30	50	0	-12	12	9	0	-50	0	-100	20	+100	0	+50	0	+50	0
50	80	0	-15	15	11	0	-50	0	-100	25	+100	0	+50	0	+50	0
80	120	0	-20	20	15	0	-50	0	-100	30	+100	0	+50	0	+50	0
120	180	0	-25	25	19	0	-50	0	-100	35	+150	0	+50	0	+100	0
180	250	0	-30	30	23	0	-50	0	-100	50	+150	0	+50	0	+100	0
250	315	0	-35	35	26	0	-50	0	-100	60	+200	0	+100	0	+100	0
315	400	0	-40	40	30	0	-50	0	-100	70	+200	0	+100	0	+100	0

Outer ring

D		Δ_{Dmp}		V_{Dp}	V_{Dmp}	K_{ea}
over	incl.	high	low	max	max	max
mm		μm		μm	μm	μm
18	30	0	-12	12	9	18
30	50	0	-14	14	11	20
50	80	0	-16	16	12	25
80	120	0	-18	18	14	35
120	150	0	-20	20	15	40
150	180	0	-25	25	19	45
180	250	0	-30	30	23	50
250	315	0	-35	35	26	60
315	400	0	-40	40	30	70
400	500	0	-45	45	34	80
500	630	0	-50	50	38	100

Bearing data – general

Table 8

Class P5 tolerances for metric taper roller bearings

Inner ring and bearing widths

d		Δ_{dmp}		V_{dp}	V_{dmp}	Δ_{Bs}		K_{ia}	S_d	Δ_{Ts}	
over	incl.	high	low	max	max	high	low	max	max	high	low
mm		μm		μm	μm	μm		μm	μm	μm	
10	18	0	-7	5	5	0	-200	5	7	+200	-200
18	30	0	-8	6	5	0	-200	5	8	+200	-200
30	50	0	-10	8	5	0	-240	6	8	+200	-200
50	80	0	-12	9	6	0	-300	7	8	+200	-200
80	120	0	-15	11	8	0	-400	8	9	+200	-200
120	180	0	-18	14	9	0	-500	11	10	+350	-250
180	250	0	-22	17	11	0	-600	13	11	+350	-250
250	315	0	-25	19	13	0	-700	16	13	+350	-250
315	400	0	-30	23	15	0	-800	19	15	+400	-400

Outer ring

D		Δ_{Dmp}		V_{Dp}	V_{Dmp}	Δ_{Cs}	K_{ea}	S_D
over	incl.	high	low	max	max		max	max
mm		μm		μm	μm		μm	μm
18	30	0	-8	6	5	Values are identical to those for inner ring of same bearing	6	8
30	50	0	-9	7	5		7	8
50	80	0	-11	8	6		8	8
80	120	0	-13	10	7		10	9
120	150	0	-15	11	8		11	10
150	180	0	-18	14	9		13	10
180	250	0	-20	15	10		15	11
250	315	0	-25	19	13		18	13
315	400	0	-28	22	14		20	13
400	500	0	-33	25	17		23	15
500	630	0	-38	29	19	25	18	

Table 9

Tolerances for inch taper roller bearings

Inner ring

d		Δ_{ds} Tolerance classes			
over	incl.	Normal, CL2		CL3, CLO	
		high	low	high	low
mm		μm			
-	76,2	+13	0	+13	0
76,2	101,6	+25	0	+13	0
101,6	266,7	+25	0	+13	0
266,7	304,8	+25	0	+13	0
304,8	609,6	+51	0	+25	0
609,6	914,4	+76	0	+38	0

Outer ring

D		Δ_{Ds} Tolerance classes				$K_{ia}, K_{ea}, S_{ia}, S_{ea}$ Tolerance classes			
over	incl.	Normal, CL2		CL3, CLO		Normal CL2		CL3	CLO
		high	low	high	low	max	max	max	max
mm		μm				μm			
-	304,8	+25	0	+13	0	51	38	8	4
304,8	609,6	+51	0	+25	0	51	38	18	9
609,6	914,4	+76	0	+38	0	76	51	51	26
914,4	1 219,2	+102	0	+51	0	76	-	76	38
1 219,2	-	+127	0	+76	0	76	-	76	-

Abutment width of single row bearing

d		D		Δ_{Ts} Tolerance classes					
over	incl.	over	incl.	Normal		CL2		CL3, CLO	
				high	low	high	low	high	low
mm		mm		μm					
-	101,6	-	-	+203	0	+203	0	+203	-203
101,6	266,7	-	-	+356	-254	+203	0	+203	-203
266,7	304,8	-	-	+356	-254	+203	0	+203	-203
304,8	609,6	-	508	+381	-381	+381	-381	+203	-203
304,8	609,6	508	-	+381	-381	+381	-381	+381	-381
609,6	-	-	-	+381	-381	-	-	+381	-381

Bearing data – general

Table 10

Tolerances for thrust bearings											
Nominal diameter d, D		Shaft washer Tolerance classes Normal, P6, P5			Tolerance classes			Housing washer Tolerance classes Normal, P6, P5			S _e max
		Δ _{dmp}		V _{dp}	Normal	P6	P5	Δ _{Dmp}		V _{Dp}	
over	incl.	high	low	max	S _i ¹⁾ max	S _i ¹⁾ max	S _i ¹⁾ max	high	low	max	max
mm		μm		μm	μm	μm	μm	μm		μm	
–	18	0	–8	6	10	5	3	0	–11	8	Values are identical to those for shaft washer of same bearing
18	30	0	–10	8	10	5	3	0	–13	10	
30	50	0	–12	9	10	6	3	0	–16	12	
50	80	0	–15	11	10	7	4	0	–19	14	
80	120	0	–20	15	15	8	4	0	–22	17	
120	180	0	–25	19	15	9	5	0	–25	19	
180	250	0	–30	23	20	10	5	0	–30	23	
250	315	0	–35	26	25	13	7	0	–35	26	
315	400	0	–40	30	30	15	7	0	–40	30	
400	500	0	–45	34	30	18	9	0	–45	34	
500	630	0	–50	38	35	21	11	0	–50	38	
630	800	0	–75	–	40	25	13	0	–75	55	
800	1 000	0	–100	–	45	30	15	0	–100	75	
1 000	1 250	0	–125	–	50	35	18	0	–125	–	
1 250	1 600	0	–160	–	60	40	21	0	–160	–	
1 600	2 000	–	–	–	–	–	–	0	–200	–	
2 000	2 500	–	–	–	–	–	–	0	–250	–	

¹⁾Does not apply to spherical roller thrust bearings

Bearing height		Tolerance classes Normal, P6, P5										SKF		SKF Explorer	
d		Δ _{Ts}		Δ _{T1s}		Δ _{T2s}		Δ _{T3s}		Δ _{T4s} ISO		high	low	high	low
over	incl.	high	low	high	low	high	low	high	low	high	low	high	low	high	low
mm		μm		μm		μm		μm		μm					
–	30	+20	–250	+100	–250	+150	–400	+300	–400	–	–	–	–	–	–
30	50	+20	–250	+100	–250	+150	–400	+300	–400	–	–	–	–	–	–
50	80	+20	–300	+100	–300	+150	–500	+300	–500	+20	–300	0	–125	0	–100
80	120	+25	–300	+150	–300	+200	–500	+400	–500	+25	–300	0	–150	0	–100
120	180	+25	–400	+150	–400	+200	–600	+400	–600	+25	–400	0	–175	0	–125
180	250	+30	–400	+150	–400	+250	–600	+500	–600	+30	–400	0	–200	0	–125
250	315	+40	–400	–	–	–	–	–	–	+40	–400	0	–225	0	–150
315	400	+40	–500	–	–	–	–	–	–	+40	–500	0	–300	0	–200
400	500	+50	–500	–	–	–	–	–	–	+50	–500	0	–420	–	–
500	630	+60	–600	–	–	–	–	–	–	+60	–600	0	–500	–	–
630	800	+70	–750	–	–	–	–	–	–	+70	–750	0	–630	–	–
800	1 000	+80	–1 000	–	–	–	–	–	–	+80	–1 000	0	–800	–	–
1 000	1 250	–	–	–	–	–	–	–	–	+100	–1 400	0	–1 000	–	–
1 250	1 600	–	–	–	–	–	–	–	–	+120	–1 600	0	–1 200	–	–

Table 11

Normal, P6 and P5 class tolerances for tapered bores, taper 1:12

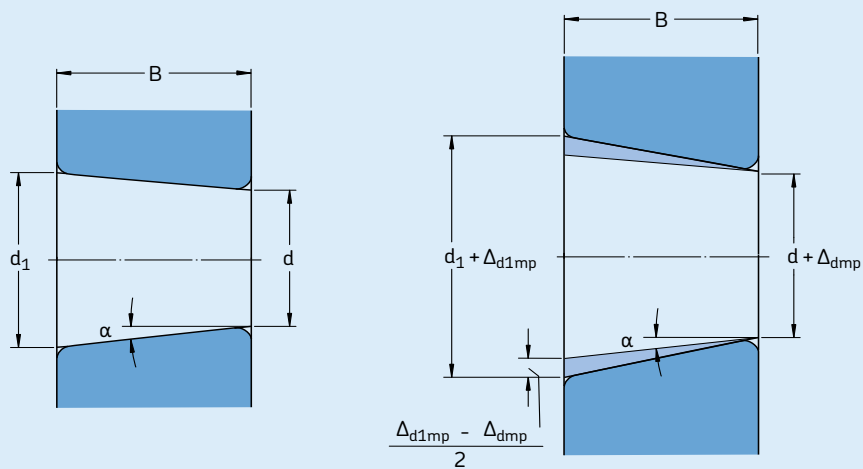

Half angle of taper 1:12
 $\alpha = 2^\circ 23' 9,4''$

Largest theoretical diameter d_1
 $d_1 = d + \frac{1}{12} \times B$

Bore diameter		Tolerance classes Normal, P6					Tolerance class P5					
d		Δ_{dmp}		$V_{dp}^{1)}$	$\Delta_{d1mp} - \Delta_{dmp}$		Δ_{dmp}		$V_{dp}^{1)}$	$\Delta_{d1mp} - \Delta_{dmp}$		
over	incl.	high	low	max	high	low	high	low	max	high	low	
mm		μm										
18	30	+21	0	13	+21	0	+13	0	13	+13	0	
30	50	+25	0	15	+25	0	+16	0	15	+16	0	
50	80	+30	0	19	+30	0	+19	0	19	+19	0	
80	120	+35	0	25	+35	0	+22	0	22	+22	0	
120	180	+40	0	31	+40	0	+25	0	25	+25	0	
180	250	+46	0	38	+46	0	+29	0	29	+29	0	
250	315	+52	0	44	+52	0	+32	0	32	+32	0	
315	400	+57	0	50	+57	0	+36	0	36	+36	0	
400	500	+63	0	56	+63	0	+40	0	–	+40	0	
500	630	+70	0	70	+70	0	+44	0	–	+44	0	
630	800	+80	0	–	+80	0	+50	0	–	+50	0	
800	1 000	+90	0	–	+90	0	+56	0	–	+56	0	
1 000	1 250	+105	0	–	+105	0	+66	0	–	+66	0	
1 250	1 600	+125	0	–	+125	0	+78	0	–	+78	0	
1 600	2 000	+150	0	–	+150	0	+92	0	–	+92	0	

¹⁾Applies in any single radial plane of the bore

Normal tolerances for tapered bores, taper 1:30

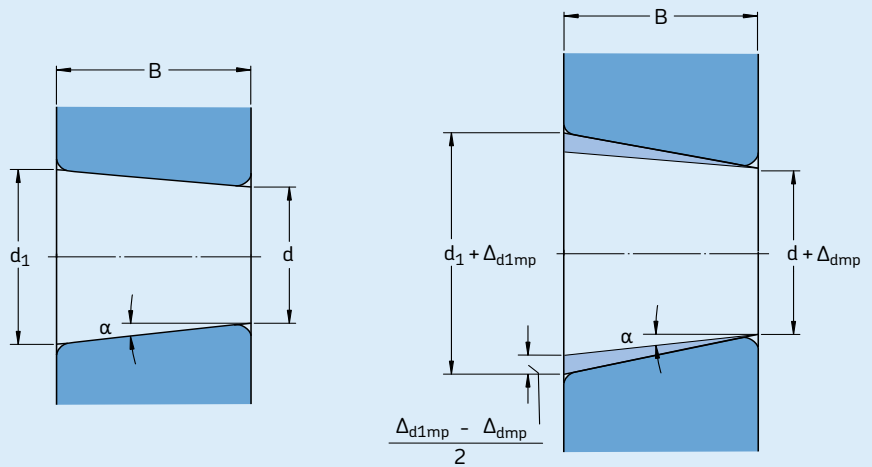

Half angle of taper 1:30
 $\alpha = 0^\circ 57' 17,4''$

Largest theoretical diameter d_1
 $d_1 = d + \frac{1}{30} \times B$

Bore diameter		Normal tolerances				
d		Δ_{dmp}		$V_{dp}^{1)}$	$\Delta_{d1mp} - \Delta_{dmp}$	
		high	low	max	high	low
mm		μm				
-	80	+15	0	19	+30	0
80	120	+20	0	22	+35	0
120	180	+25	0	40	+40	0
180	250	+30	0	46	+46	0
250	315	+35	0	52	+52	0
315	400	+40	0	57	+57	0
400	500	+45	0	63	+63	0
500	630	+50	0	70	+70	0
630	800	+75	0	-	+100	0
800	1 000	+100	0	-	+100	0
1 000	1 250	+125	0	-	+115	0
1 250	1 600	+160	0	-	+125	0
1 600	2 000	+200	0	-	+150	0

¹⁾Applies in any single plane of the bore

Table 13

Chamfer dimension limits for metric radial and thrust bearings, except taper roller bearings

Minimum single chamfer dimension	Nominal bearing bore diameter		Maximum chamfer dimensions		
	r_s min	d over incl.	Radial bearings	Thrust bearings	
			$r_{1,3}$ max	$r_{2,4}$ max	$r_{1,2,3,4}$ max
mm	mm		mm		
0,05	–	–	0,1	0,2	0,1
0,08	–	–	0,16	0,3	0,16
0,1	–	–	0,2	0,4	0,2
0,15	–	–	0,3	0,6	0,3
0,2	–	–	0,5	0,8	0,5
0,3	–	40	0,6	1	0,8
	40	–	0,8	1	0,8
0,6	–	40	1	2	1,5
	40	–	1,3	2	1,5
1	–	50	1,5	3	2,2
	50	–	1,9	3	2,2
1,1	–	120	2	3,5	2,7
	120	–	2,5	4	2,7
1,5	–	120	2,3	4	3,5
	120	–	3	5	3,5
2	–	80	3	4,5	4
	80	220	3,5	5	4
	220	–	3,8	6	4
2,1	–	280	4	6,5	4,5
	280	–	4,5	7	4,5
2,5	–	100	3,8	6	–
	100	280	4,5	6	–
	280	–	5	7	–
3	–	280	5	8	5,5
	280	–	5,5	8	5,5
4	–	–	6,5	9	6,5
5	–	–	8	10	8
6	–	–	10	13	10
7,5	–	–	12,5	17	12,5
9,5	–	–	15	19	15
12	–	–	18	24	18

Table 14

Chamfer dimension limits for metric radial taper roller bearings

Minimum single chamfer dimension	Nominal bearing bore/outside diameter		Maximum chamfer dimensions	
	r_s min	d, D over incl.	$r_{1,3}$ max	$r_{2,4}$ max
mm	mm		mm	
0,3	–	40	0,7	1,4
	40	–	0,9	1,6
0,6	–	40	1,1	1,7
	40	–	1,3	2
1	–	50	1,6	2,5
	50	–	1,9	3
1,5	–	120	2,3	3
	120	250	2,8	3,5
	250	–	3,5	4
2	–	120	2,8	4
	120	250	3,5	4,5
	250	–	4	5
2,5	–	120	3,5	5
	120	250	4	5,5
	250	–	4,5	6
3	–	120	4	5,5
	120	250	4,5	6,5
	250	400	5	7
	400	–	5,5	7,5
4	–	120	5	7
	120	250	5,5	7,5
	250	400	6	8
	400	–	6,5	8,5
5	–	180	6,5	8
	180	–	7,5	9
6	–	180	7,5	10
	180	–	9	11

Table 15

Chamfer dimension limits for inch taper roller bearings									
Minimum single chamfer dimension		Inner ring Nominal bearing bore diameter		Maximum chamfer dimensions		Outer ring Nominal bearing outside diameter		Maximum chamfer dimensions	
r _s min over	incl.	d over	incl.	r ₁ max	r ₂ max	D over	incl.	r ₃ max	r ₄ max
mm		mm		mm		mm		mm	
0,6	1,4	101,6 254	101,6 254	r ₁ min + 0,5	r ₂ min + 1,3	168,3 266,7 355,6	168,3 266,7 355,6	r ₃ min + 0,6	r ₄ min + 1,2
				r ₁ min + 0,6	r ₂ min + 1,8			r ₃ min + 0,8	r ₄ min + 1,4
				r ₁ min + 0,9	r ₂ min + 2			r ₃ min + 1,7	r ₄ min + 1,7
1,4	2,5	101,6 254	101,6 254	r ₁ min + 0,5	r ₂ min + 1,3	168,3 266,7 355,6	168,3 266,7 355,6	r ₃ min + 0,6	r ₄ min + 1,2
				r ₁ min + 0,6	r ₂ min + 1,8			r ₃ min + 0,8	r ₄ min + 1,4
				r ₁ min + 2	r ₂ min + 3			r ₃ min + 1,7	r ₄ min + 1,7
2,5	4,0	101,6 254 400	101,6 254 400	r ₁ min + 0,5	r ₂ min + 1,3	168,3 266,7 355,6 400	168,3 266,7 355,6 400	r ₃ min + 0,6	r ₄ min + 1,2
				r ₁ min + 0,6	r ₂ min + 1,8			r ₃ min + 0,8	r ₄ min + 1,4
				r ₁ min + 2	r ₂ min + 4			r ₃ min + 1,7	r ₄ min + 1,7
4,0	5,0	101,6 254	101,6 254	r ₁ min + 0,5	r ₂ min + 1,3	168,3 266,7 355,6	168,3 266,7 355,6	r ₃ min + 0,6	r ₄ min + 1,2
				r ₁ min + 0,6	r ₂ min + 1,8			r ₃ min + 0,8	r ₄ min + 1,4
				r ₁ min + 2,5	r ₂ min + 4			r ₃ min + 1,7	r ₄ min + 1,7
5,0	6,0	101,6 254	101,6 254	r ₁ min + 0,5	r ₂ min + 1,3	168,3 266,7 355,6	168,3 266,7 355,6	r ₃ min + 0,6	r ₄ min + 1,2
				r ₁ min + 0,6	r ₂ min + 1,8			r ₃ min + 0,8	r ₄ min + 1,4
				r ₁ min + 3	r ₂ min + 5			r ₃ min + 1,7	r ₄ min + 1,7
6,0	7,5	101,6 254	101,6 254	r ₁ min + 0,5	r ₂ min + 1,3	168,3 266,7 355,6	168,3 266,7 355,6	r ₃ min + 0,6	r ₄ min + 1,2
				r ₁ min + 0,6	r ₂ min + 1,8			r ₃ min + 0,8	r ₄ min + 1,4
				r ₁ min + 4,5	r ₂ min + 6,5			r ₃ min + 1,7	r ₄ min + 1,7
7,5	9,5	101,6 254	101,6 254	r ₁ min + 0,5	r ₂ min + 1,3	168,3 266,7 355,6	168,3 266,7 355,6	r ₃ min + 0,6	r ₄ min + 1,2
				r ₁ min + 0,6	r ₂ min + 1,8			r ₃ min + 0,8	r ₄ min + 1,4
				r ₁ min + 6,5	r ₂ min + 9,5			r ₃ min + 1,7	r ₄ min + 1,7
9,5	12	101,6 254	101,6 254	r ₁ min + 0,5	r ₂ min + 1,3	168,3 266,7 355,6	168,3 266,7 355,6	r ₃ min + 0,6	r ₄ min + 1,2
				r ₁ min + 0,6	r ₂ min + 1,8			r ₃ min + 0,8	r ₄ min + 1,4
				r ₁ min + 8	r ₂ min + 11			r ₃ min + 1,7	r ₄ min + 1,7
								r ₃ min + 8	r ₄ min + 11

Bearing internal clearance

Bearing internal clearance (→ **fig. 5**) is defined as the total distance through which one bearing ring can be moved relative to the other in the radial direction (radial internal clearance) or in the axial direction (axial internal clearance).

It is necessary to distinguish between the internal clearance of a bearing, before mounting and the internal clearance in a mounted bearing, which has reached its operating temperature (operational clearance). The initial internal clearance (before mounting) is greater than the operational clearance because different degrees of interference in the fits and differences in thermal expansion of the bearing rings and the associated components cause the rings to be expanded or compressed.

The radial internal clearance of a bearing is of considerable importance if satisfactory operation is to be obtained. As a general rule, ball bearings should always have an operational clearance that is virtually zero, or there may be a slight preload. Cylindrical, spherical and CARB toroidal roller bearings, on the other hand, should always have some residual clearance – however small – in operation. The same is true of taper roller bearings, except in bearing arrangements where stiffness is desired, e.g. pinion bearing arrangements, where the bearings are mounted with a certain amount of preload (→ section “Bearing preload”, starting on **page 206**).

The bearing internal clearance referred to as Normal has been selected so that a suitable

operational clearance will be obtained when bearings are mounted with the fits usually recommended and operating conditions are normal. Where operating and mounting conditions differ from the normal, e.g. where interference fits are used for both bearing rings, unusual temperatures prevail etc., bearings with greater or smaller internal clearance than Normal are required. In such cases, SKF recommends checking residual clearance in the bearing after it has been mounted.

Bearings having an internal clearance other than Normal are identified by the suffixes C1 to C5 (→ **table 16**).

Tables providing the clearance values for the various bearing types can be found in the text preceding the relevant product section. For paired single row angular contact ball bearings and taper roller bearings, double row angular contact ball bearings and four-point contact ball bearings, values for the axial internal clearance are provided instead of radial clearance, as the axial clearance is of greater importance in application design for these bearing types.

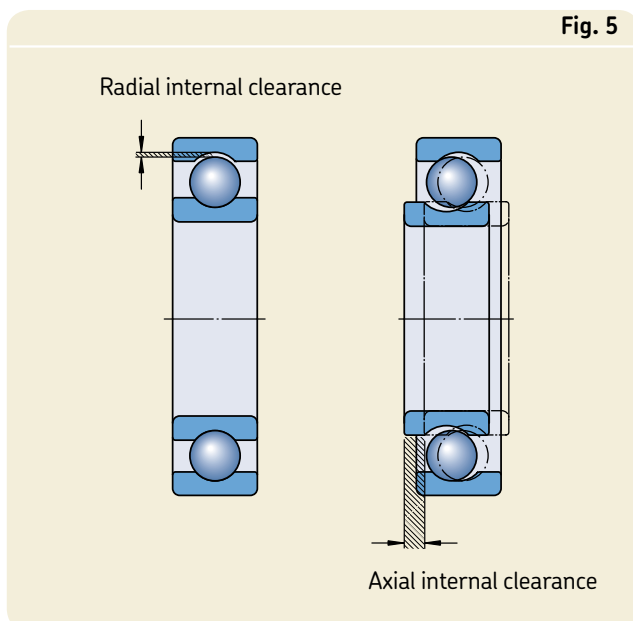

Table 16

Supplementary designation for internal clearance

Suffix	Internal clearance
C1	Less than C2
C2	Less than Normal
CN	Normal, only used in combination with letters indicating reduced or displaced clearance range.
C3	Greater than Normal
C4	Greater than C3
C5	Greater than C4

Materials for rolling bearings

The materials from which the bearing components are made determine to a large extent the performance and reliability of rolling bearings. For the bearing rings and rolling elements typical considerations include hardness for load carrying capacity, fatigue resistance under rolling contact conditions, under clean or contaminated lubrication conditions, and the dimensional stability of the bearing components. For the cage, considerations include friction, strain, inertia forces, and in some cases, the chemical action of certain lubricants, solvents, coolants and refrigerants. The relative importance of these considerations can be affected by other operational parameters such as corrosion, elevated temperatures, shock loads or combinations of these and other conditions.

Because SKF has the competence and facilities to provide a variety of materials, processes and coatings, SKF application engineers can assist in selecting those bearings that will provide superior performance for particular applications.

Contact seals integrated in rolling bearings can also have a considerable impact on the performance and reliability of the bearings. The materials they are made of have to offer excellent oxidation, thermal or chemical resistance.

In order to meet the needs of various applications, SKF uses different materials for bearing rings, rolling elements, cages and seals. Furthermore, in applications where sufficient lubrication cannot be achieved or where an electric current passing through the bearings has to be prevented, SKF bearings can be supplied with special coatings.

Materials for bearing rings and rolling elements

Bearing steels for through-hardening

The most common steel for through-hardening is a carbon chromium steel, containing approximately 1 % carbon and 1,5 % chromium, according to ISO 683-17:1999. Today, carbon-chromium steel is one of the oldest and most intensively investigated steels; due to the continuously increasing demands for extended bearing service life. The composition of this roll-

ing bearing steel provides an optimum balance between manufacturing and application performance. This steel is normally given a martensitic or bainitic heat treatment during which it is hardened to the range of 58 to 65 HRC.

Within the last few years process developments have enabled more stringent cleanliness specifications to be realized, which has had a significant impact on the consistency and quality of SKF's bearing steel. The reduction of oxygen and harmful non-metallic inclusions has led to significantly improved properties of rolling bearing steels – the steels from which the SKF Explorer class bearings are made.

Bearing steels for induction-hardening

Surface induction-hardening offers the possibility to selectively harden a component's raceway, while leaving the remainder of the component unaffected by the hardening process. The steel grade and the manufacturing processes used prior to surface induction-hardening dictate the properties in the unaffected area, which means that a combination of properties can be achieved in one component.

An example of this is a flanged wheel hub bearing unit (HBU) where the properties of the unhardened flange are designed to resist structural fatigue, while the raceway is designed to resist rolling contact fatigue.

Bearing steels for case-hardening

Chromium-nickel and manganese-chromium alloyed steels according to ISO 683-17:1999 with a carbon content of approximately 0,15 % are those steels for case-hardening most commonly used for SKF rolling bearings.

In applications where there are high tensile interference fits and heavy shock loads, bearings with case-hardened rings and/or rolling elements are recommended.

Stainless bearing steels

The most common stainless steels used for SKF bearing rings and rolling elements are the high chromium content steels X65Cr14 according to ISO 683-17:1999 and X105CrMo17 according to EN 10088-1:1995.

It should be noted that for some applications, corrosion resistant coatings might be an excellent alternative to stainless steel. For additional information about alternative coatings, please consult the SKF application engineering service.

High-temperature bearing steels

Depending on the bearing type, standard bearings made from steels for through-hardening and surface-hardening have a recommended maximum operating temperature, which differs between 120 and 200 °C. The maximum operating temperature is directly related to the heat treatment process used in manufacturing components.

For operating temperatures up to 250 °C; a special heat treatment (stabilization) can be applied. In this case a reduction of the load carrying capacity of the bearing has to be taken into account.

For bearings operated at elevated temperatures, higher than 250 °C, for extended periods, highly alloyed steels like the 80MoCrV42-16 manufactured to ISO 683-17:1999 should be used, because they retain their hardness and bearing performance characteristics even under extreme temperature conditions.

For additional information about high temperature bearing steels, please contact the SKF application engineering service.

Ceramics

The common ceramic used for SKF bearing rings and rolling elements is a bearing grade silicon nitride material. It consists of fine elongated grains of beta-silicon nitride in a glassy phase matrix. It provides a combination of favourable properties for rolling bearings, such as high hardness, low density, low thermal expansion, high electric resistivity, low dielectric constant and no response to magnetic fields (→ **table 17**).

Table 17

Comparison of the material properties of bearing steel and silicon nitride		
Material properties	Bearing steel	Bearing grade silicon nitride
Mechanical properties		
Density (g/cm ³)	7,9	3,2
Hardness	700 HV10	1 600 HV10
Modulus of elasticity (kN/mm ²)	210	310
Thermal expansion (10 ⁻⁶ /K)	12	3
Electrical properties (at 1 MHz)		
Electrical resistivity (Ωm)	0,4 × 10 ⁻⁶ (Conductor)	10 ¹² (Insulator)
Dielectric strength (kV/mm)	–	15
Relative dielectric constant	–	8

Cage materials

Sheet steel cages

The majority of pressed sheet steel cages are made from continuously hot-rolled low carbon sheet steel according to EN 10111:1998. These lightweight cages have relatively high strength and can be surface treated to further reduce friction and wear.

Pressed cages normally used in stainless steel bearings are made from stainless steel X5CrNi18-10 according to EN 10088-1:1995.

Machined steel cages

Machined steel cages are normally made of non-alloyed structural steel of type S355GT (St 52) according to EN 10 025:1990 + A:1993. To improve sliding and wear-resistance properties some machined steel cages are surface treated.

Machined steel cages are used for large-size bearings or in applications where there is a danger that season cracking, caused by a chemical reaction, may occur if a brass cage were used. Steel cages can be used at operating temperatures up to 300 °C. They are not affected by the mineral or synthetic oil-based lubricants normally used for rolling bearings, or by the organic solvents used to clean bearings.

Sheet brass cages

Pressed sheet brass cages are used for some small and medium-sized bearings. The brass used for these cages conforms to EN 1652:1997. In applications such as compressors for refrigeration using ammonia, season cracking in sheet brass might occur, therefore machined brass or steel cages should be used instead.

Machined brass cages

Most brass cages are machined from a CW612N cast or wrought brass according to EN 1652:1997. They are unaffected by most common bearing lubricants, including synthetic oils and greases, and can be cleaned using normal organic solvents. Brass cages should not be used at temperatures in excess of 250 °C.

Polymer cages

Polyamide 6,6

For the majority of injection moulded cages polyamide 6,6 is used. This material, with glass fibre reinforcement or without, is characterized by a favourable combination of strength and elasticity. The mechanical properties like strength and elasticity of polymeric materials are temperature dependent and subject to permanent changes under operating conditions, called ageing. The most important factors that play a role in this ageing behaviour are temperature, time and the medium (lubricant) to which the polymer is exposed. The relationship between these factors for glass fibre reinforced polyamide 6,6 is illustrated in **diagram 1**. It appears that the cage life decreases with increasing temperature and the aggressiveness of the lubricant.

Therefore, whether polyamide cages are suitable for a specific application depends on the operating conditions and life requirements. In **table 18** the classification of lubricants into “aggressive” and “mild” is reflected by the “permissible operating temperature” for the use of cages made from glass fibre reinforced polyamide 6,6 in various lubricants. The permissible operating temperature in this table is defined as the temperature, which gives a cage ageing life of at least 10 000 operating hours.

Some media are even more “aggressive” than those listed in **table 18**. A typical example is ammonia applied as refrigerant in compressors. In those cases, cages made from glass fibre reinforced polyamide 6,6 should not be used at operating temperatures above +70 °C.

Towards the low operating temperature side, also a limit can be set since polyamide loses its elasticity, which can result in cage failures. Cages made from glass fibre reinforced polyamide 6,6 should for this reason not be applied at a continuous operating temperature below -40 °C.

Where a high degree of toughness is a dominant factor, such as in railway axleboxes, a super-tough modification of polyamide 6,6 is applied. Please consult the SKF application engineering service for cage availability for specific bearing executions.

Table 18

Permissible operating temperatures for cages of glass fibre reinforced polyamide 6,6 with various bearing lubricants

Lubricant	Permissible operating temperature ¹⁾
Mineral oils	
Oils without EP additives, e.g. machine or hydraulic oils	120 °C
Oils with EP additives, e.g. industrial and automotive gearbox oils	110 °C
Oils with EP additives, e.g. automotive rear axle and differential gear oils (automotive), hypoid gear oils	100 °C
Synthetic oils	
Polyglycols, poly-alpha-olefins	120 °C
Diesters, silicones	110 °C
Phosphate esters	80 °C
Greases	
Lithium greases	120 °C
Polyurea, bentonite, calcium complex greases	120 °C
For sodium and calcium greases and other greases with a maximum operating temperature below 120 °C, the maximum temperature for the polyamide cage is the same as the maximum operating temperature for the grease.	

¹⁾ Measured on the outside surface of the outer ring

Polyamide 4,6

Glass fibre reinforced polyamide 4,6 is used for some small and medium size CARB toroidal roller bearings as standard. These cages have a 15 °C higher permissible operating temperature than those made from glass fibre reinforced polyamide 6,6.

Polyetheretherketone (PEEK)

The use of the glass fibre reinforced PEEK for cages has become common within SKF for demanding conditions regarding high speeds, chemical attack or high temperatures. The exceptional properties of PEEK are superior combination of strength and flexibility, high operating temperature range, high chemical and wear resistance and good processability. Due to these outstanding features, PEEK cages are available as standard for some ball and cylindrical roller bearings, like hybrid and/or high-precision bearings. The material does not show signs of ageing by temperature and oil additives up to +200 °C. However, the maximum temperature for high-speed use is limited to +150 °C as this is the softening temperature of the polymer.

Diagram 1

Cage ageing life for glass fibre reinforced polyamide 6,6

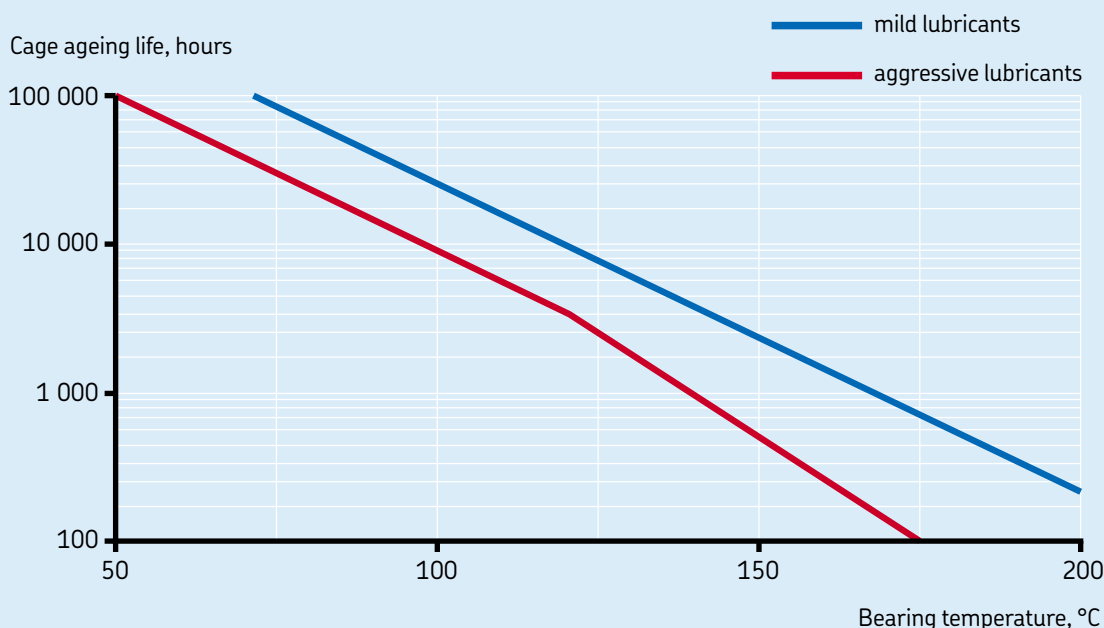

Bearing data – general

Phenolic resin

Lightweight, fabric reinforced phenolic resin cages can withstand heavy centrifugal as well as acceleration forces, but are not able to accommodate high operating temperatures. In most cases, these cages are used as standard in high-precision angular contact ball bearings.

Other materials

In addition to the materials described above, SKF bearings for special applications may be fitted with cages made of other engineering polymer materials, light alloys or special cast iron. For information on cages made from alternative materials please consult the SKF application engineering service.

Seal materials

Seals integrated in SKF bearings are typically made from elastomer materials. The type of material can depend on the series and size of the bearing as well as the application requirements. SKF seals are generally produced from the materials listed below.

Acrylonitrile-butadiene rubber

Acrylonitrile-butadiene rubber (NBR) is the “universal” seal material. This copolymer, produced from acrylonitrile and butadiene, shows good resistance to the following media

- most mineral oils and greases with a mineral oil base
- normal fuels: petrol, diesel and light heating oils
- animal and vegetable oils and fats
- hot water.

It also tolerates short-term dry running of the sealing lip. The permissible operating temperature range is -40 to $+100$ °C; for brief periods temperatures of up to $+120$ °C can be tolerated. At higher temperatures the material hardens.

Hydrogenated acrylonitrile-butadiene rubber

Hydrogenated acrylonitrile-butadiene rubber (HNBR) has appreciably better wear characteristics than nitrile rubber so that seals made of this material have a longer service life. Hydrogenated acrylonitrile-butadiene rubber is also

more resistant to heat, ageing and hardening in hot oil or ozone.

Mixtures of oil in air may have a negative impact on seal life. The upper operating temperature limit is $+150$ °C, which is appreciably higher than that of normal nitrile rubber.

Fluoro rubber

Fluoro rubbers (FKM) are characterized by their high thermal and chemical resistance. Their resistance to ageing and ozone is very good and their gas permeability is very slight. They have exceptionally good wear-characteristics even under harsh environmental conditions and can withstand operating temperatures up to $+200$ °C. Seals made from this material can tolerate dry running of the lip for short periods.

Fluoro rubbers are also resistant to oils and hydraulic fluids, fuels and lubricants, mineral acids and aliphatic as well as aromatic hydrocarbons, which would cause seals made from other materials to fail. In the presence of esters, ethers, ketones, certain amines and hot anhydrous hydrofluorides fluoro rubbers should not be used.

At temperatures above 300 °C, fluoro rubber gives off dangerous fumes. As handling seals made of fluoro rubber constitutes a potential safety risk, the safety precautions mentioned hereafter must always be considered.

Polyurethane

Polyurethane (AU) is a wear-resistant organic material, which has good elastic properties. It withstands operating temperatures in the range of -20 up to $+80$ °C. It has good resistance to mineral oil based greases, mineral oils with no or low quantity of EP additives, water and water-oil mixtures for example. It is not resistant to acids, alkalics or polar solvents.

WARNING!

Safety precautions for fluoro rubber

Fluoro rubber is very stable and harmless in normal operating conditions up to +200 °C. However, if exposed to extreme temperatures above 300 °C, e.g. fire or the flame of a cutting torch, fluoro rubber seals give off hazardous fumes. These fumes can be harmful if inhaled, as well as to the eyes. In addition, once the seals have been heated to such temperatures, they are dangerous to handle even after they have cooled and should not be in contact with the skin. If it is necessary to handle bearings with seals that have been subjected to high temperatures, such as when dismantling the bearing, the following safety precautions should be observed:

- Always wear protective goggles, gloves and appropriate breathing apparatus.
- Place the remains of the seals in an airtight plastic container marked with a symbol for “material will etch”.
- Follow the safety precautions in the appropriate material safety data sheet (MSDS).

If there is unintentional contact with the seals, wash hands with soap and plenty of water and flush eyes with plenty of water and consult a doctor immediately. If the fumes have been inhaled, consult a doctor immediately.

The user is responsible for the correct use of the product during its service life and its proper disposal. SKF takes no responsibility for the improper handling of fluoro rubber seals or for any injury resulting from their use.

Coatings

Coating is a well-established method to upgrade materials and to provide bearings with additional features for specific application conditions. Two different coating methods developed by SKF are available and already successfully proven in many applications.

The surface coating, trademarked NoWear, applies a low friction ceramic coating on the bearing inner surfaces to withstand long periods of operation under marginal lubrication for example. More details can be found in the section “NoWear bearings”, starting on **page 943**.

The SKF INSOCOAT® coating, which can be applied to the external surfaces of the outer ring or inner ring of a bearing, offers resistance to the damage that can be caused by the passage of electric current through the bearing. More details can be found in the section “INSOCOAT bearings”, starting on **page 911**.

Other coatings like zinc chromate for example, can offer an alternative to stainless steel in a corrosive environment, especially for ready-to-mount bearing units.

Cages

Cages have an appreciable influence on the suitability of rolling bearings. Their main purposes are

- keeping the rolling elements at an appropriate distance from each other and to prevent direct contact between neighbouring rolling elements, in order to keep friction and thus heat generation at a minimum
- keeping the rolling elements evenly distributed around the complete circumference to provide even load distribution and quiet and uniform running
- guiding the rolling elements in the unloaded zone, to improve the rolling conditions in the bearing and to prevent damaging sliding movements
- retaining the rolling elements, where bearings are of a separable design and one bearing ring is removed during mounting or dismounting.

Cages are mechanically stressed by frictional, strain and inertia forces and they may also be subjected to the chemical action of certain lubricants, lubricant additives or products of their ageing, organic solvents or coolants. Therefore the design and material are of paramount importance for the performance of the cage as well as for the operational reliability of the bearing itself. This is the reason why SKF has developed various cage types and designs of different materials for the different bearing types.

In the introductory text to each product section information is provided about the standard cages fitted to the bearings and also possible alternatives. If a bearing with a non-standard cage is required, it is always advisable to check availability before ordering.

In general, the cages for SKF rolling bearings can be classified as pressed, solid or pin-type cages

Pressed cages

Pressed cages for SKF bearings (→ **fig. 6**) generally are made of sheet steel and with some exceptions of sheet brass. Depending on the bearing type pressed cages are designed as

- ribbon-type brass or steel cage (**a**)
- riveted steel cage (**b**)
- snap-type brass or steel cage (**c**)
- extremely strong window-type steel cage (**d**).

Pressed cages offer the advantage of lower weight as well as the advantage of more space inside the bearing, which facilitates entry of the lubricant into the bearing.

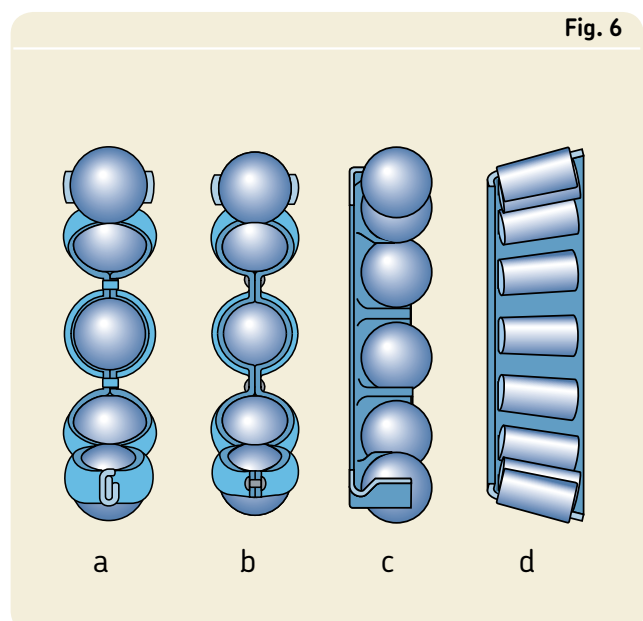

Solid cages

Solid cages for SKF bearings (→ **fig. 7**) are made from brass, steel, light alloy, polymer or fabric reinforced phenolic resin. Depending on the bearing design they are designed as

- two-piece machined riveted cage (**a**)
- two-piece machined cage with integral rivets (**b**)
- one-piece machined window-type cage (**c**)
- double pronged machined cage (**d**)
- injection moulded polymer window-type cage (**e**)
- injection moulded polymer snap-type cage (**f**)
- one-piece machined cage of fabric reinforced phenolic resin.

Machined metal cages generally permit higher speeds and are necessary when movements additional to pure rotation are superimposed, particularly when conditions of high acceleration prevail. Suitable steps must be taken (e.g. oil lubrication) to provide sufficient supply of lubricant to the guiding surfaces of the cage and to the inside of the bearing. Machined cages are centred (→ **fig. 8**) either on the

- rolling elements (**a**)
- inner ring shoulder(s) (**b**)
- outer ring shoulder(s) (**c**)

and are thus radially guided.

Fig. 8

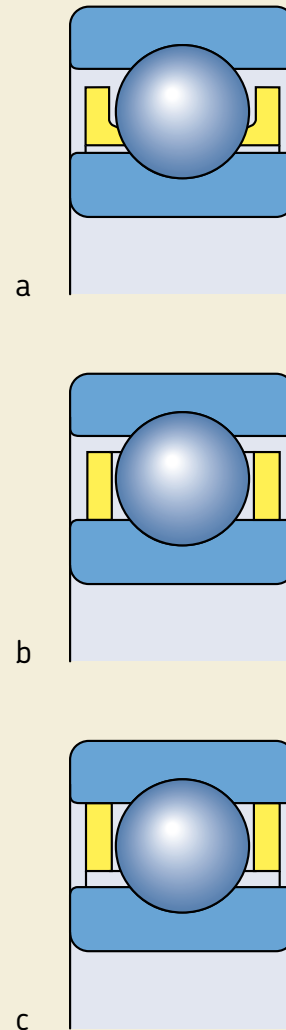
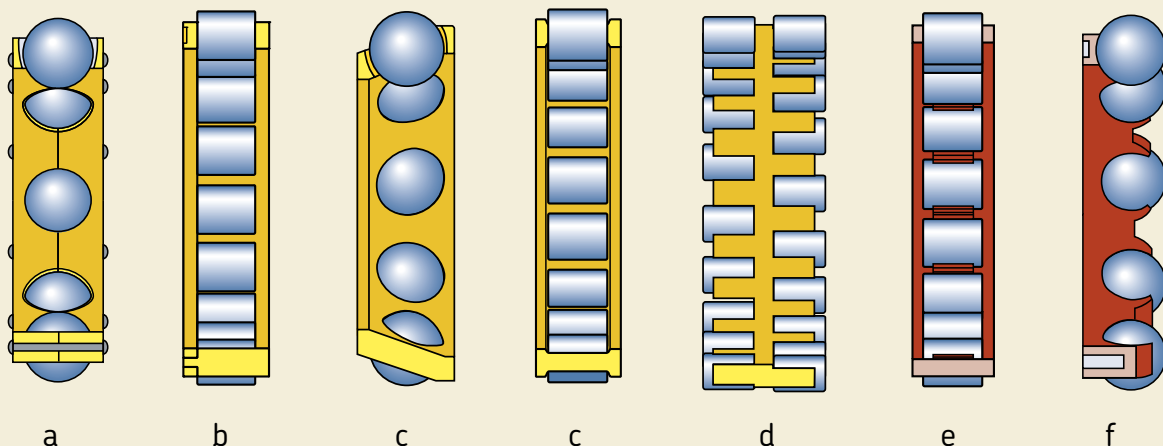

Fig. 7



Bearing data – general

Solid polymer cages are characterized by a favourable combination of strength and elasticity. The good sliding properties of the polymer on lubricated steel surfaces and the smoothness of the cage surfaces in contact with the rolling elements produce just little friction so that heat generation and wear in the bearing are at a minimum. The low density of the material means that the inertia of the cage is small. The excellent running properties of polymer cages under lubricant starvation conditions permit continued operation of the bearing for some time without risk of seizure and secondary damage.

Pin-type cages

Steel pin-type cages need pierced rollers (→ **fig. 9**) and are only used together with large-sized roller bearings. These cages have relative low weight and enable a large number of rollers being incorporated.

Materials

Detailed information about materials used for cages can be found in the section “Materials for rolling bearings”, starting on **page 138**.

Fig. 9

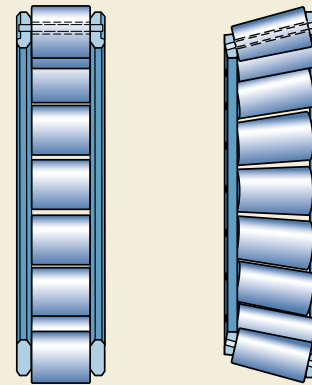

Designations

Designations of rolling bearings consist of combinations of figures and/or letters, the significance of which is not immediately apparent. Therefore, the SKF designation system for rolling bearings will be described and the significance of the more common supplementary designations explained. To avoid confusion, the designations used for specific rolling bearing types, such as needle roller bearings, Y-bearings or high-precision bearings are not covered. More information about these can be found in the relevant catalogues. Also very specific bearing types, such as fixed-section bearings, slewing bearings or linear bearings are not covered either. These designations differ sometimes considerably from the system described here.

Bearing designations are divided into two main groups: designations for standard bearings and designations for special bearings. Standard bearings are bearings that normally have standardized dimensions, whereas special bearings have special dimensions dictated by customer demands. These customized bearings are also referred to as “drawing number” bearings and they will not be covered in detail in this section.

The complete designation may consist of a basic designation with or without one or more supplementary designations (→ **diagram 2**). The complete bearing designation, i.e. the basic designation with supplementary designations is always marked on the bearing package, whereas the designation marked on the bearing may sometimes be incomplete, e.g. for manufacturing reasons.

Basic designations identify the

- type
- basic design
- standard boundary dimensions

of a bearing. Supplementary designations identify

- bearing components and/or
- variants having a design and/or feature(s) that differ in some respect from the basic design.

Supplementary designations may precede the basic designation (prefixes) or follow it (suffixes). Where several supplementary designations

are used to identify a given bearing, they are always written in a given order (→ **diagram 4, page 150**).

The list of supplementary designations presented in the following is not exhaustive, but includes those most commonly used.

Diagram 2

Bearing designation system

Examples

R	NU 2212		ECML
W	6008	/	C3
	23022	-	2CS

Prefix

Space or non-separated

Basic designation

Space, oblique stroke or hyphen

Suffix

Basic designations

All SKF standard bearings have a characteristic basic designation, which generally consists of 3, 4 or 5 figures, or a combination of letters and figures. The design of the system used for almost all standard ball and roller bearing types is shown schematically in **diagram 3**. The figures and combinations of letters and figures have the following meaning:

- The first figure or the first letter or combination of letters identifies the bearing type; the actual bearing type can be seen from the presentation (→ **diagram 3**).
- The following two figures identify the ISO Dimension Series; the first figure indicates the Width or Height Series (dimensions B, T or H) and the second the Diameter Series (dimension D).
- The last two figures of the basic designation give the size code of the bearing; when multiplied by 5, the bore diameter in millimetres is obtained.

But there is no rule without some exceptions. The most important ones in the bearing designation system are listed below.

1. In a few cases the figure for the bearing type and/or the first figure of the Dimension Series identification is omitted. These figures are given in brackets in **diagram 3**.
2. For bearings having a bore diameter smaller than 10 mm or equal to or greater than 500 mm, the bore diameter is generally given in millimetres and is not coded. The size identification is separated from the rest of the bearing designation by an oblique stroke, e.g. 618/8 (d = 8 mm) or 511/530 (d = 530 mm).
This is also true of standard bearings according to ISO 15:1998 that have bore diameters of 22, 28 or 32 mm, e.g. 62/22 (d = 22 mm).
3. Bearings with bore diameters of 10, 12, 15 and 17 mm have the following size code identifications:
00 = 10 mm
01 = 12 mm
02 = 15 mm
03 = 17 mm

4. For some smaller bearings having a bore diameter below 10 mm, such as deep groove, self-aligning and angular contact ball bearings, the bore diameter is also given in millimetres (uncoded) but is not separated from the series designation by an oblique stroke, e.g. 629 or 129 (d = 9 mm).
5. Bore diameters that deviate from the standard bore diameter of a bearing have always been given uncoded, in millimetres with up to three decimal places. This bore diameter identification is part of the basic designation and is separated from the basic designation by an oblique stroke, e.g. 6202/15.875 (d = 15,875 mm = $\frac{5}{8}$ in).

Series designations

Each standard bearing belongs to a given bearing series, which is identified by the basic designation without the size identification. Series designations often include a suffix A, B, C, D or E or a combination of these letters e.g. CA. These are used to identify differences in internal design, e.g. contact angle.

The most common series designations are shown in **diagram 3** above the bearing sketches. The figures in brackets are not included in the series designation.

Designation system for SKF standard metric ball and roller bearings

Bearing series				6(0)4									
				544	623					(0)4			
	223			524	6(0)3					33			
	213			543	622					23			
	232			523	6(0)2		23		(0)3				
	222			542	630		32		22				
	241			522	6(1)0		22		12				
	231				16(0)0		41		(0)2				
	240	323		534	639		31	31	41				
	230	313		514	619		60	30	31				
	249	303		533	609		50	20	60				
	239	332		513	638	7(0)4	814	40	10	50			
139	248	322		532	628	7(0)3	894	30	39	40			23
130	238	302		512	618	7(0)2	874	69	29	30			(0)3
(1)23		331		511	608	7(1)0	813	59	19	69			12
1(0)3													
(1)22	294	330		510	637	719	893	49	38	49			(0)2
(0)33	1(0)2	293	320	4(2)3	591	627	718	812	39	28	39		10
(0)32	1(1)0	292	329	4(2)2	590	617	708	811	29	18	48		19

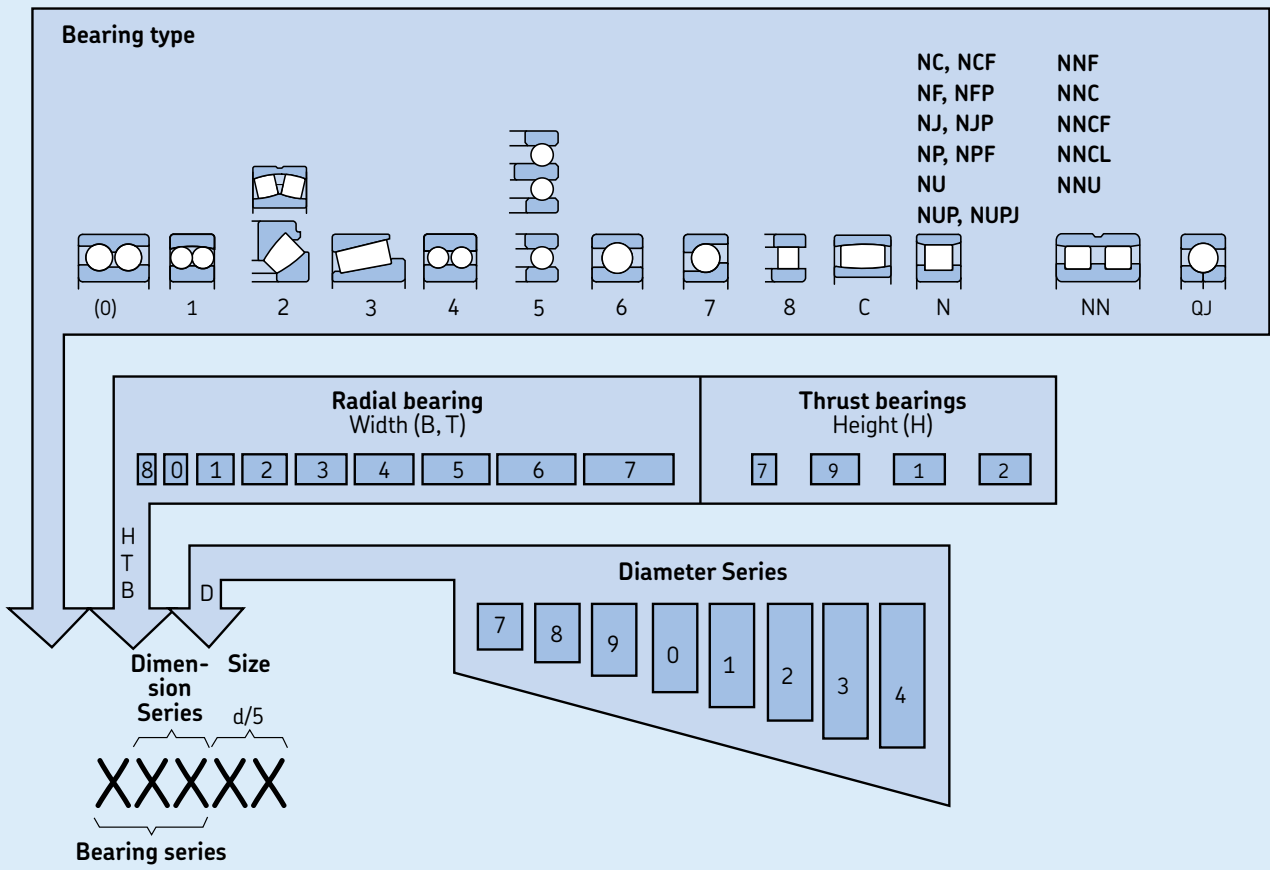

Code	Bearing type	Code	Bearing type	Code	Bearing type
0	Double row angular contact ball bearings	7	Single row angular contact ball bearings	QJ	Four-point contact ball bearings
1	Self-aligning ball bearings	8	Cylindrical roller thrust bearings	T	Taper roller bearings according to ISO 355-1977
2	Spherical roller bearings, spherical roller thrust bearings	C	CARB toroidal roller bearings		
3	Taper roller bearings	N	Cylindrical roller bearings. A second and sometimes a third letter are used to identify the number of the rows or the configuration of the flanges, e.g. NJ, NU, NUP, NN, NNU, NNCF etc.		
4	Double row deep groove ball bearings				
5	Thrust ball bearings				
6	Single row deep groove ball bearings				

Designation system for suffixes

Designation example

6205-RS1NRTN9/P63LT20CVB123

23064 CCK/HA3C084S2W33

Group 1	Group 2	Group 3	/	Group 4					
				4.1	4.2	4.3	4.4	4.5	4.6
6205	-RS1NR	TN9	/		P63			LT20C	VB123
23064	CC	K	/	HA3	C084		S2	W33	

Basic designation

Space

Suffixes

Group 1: Internal design

Group 2: External design (seals, snap ring groove etc.)

Group 3: Cage design

Oblique stroke

Group 4: Variants

Group 4.1: Materials, heat treatment

Group 4.2: Accuracy, clearance, quiet running

Group 4.3: Bearing sets, paired bearings

Group 4.4: Stabilization

Group 4.5: Lubrication

Group 4.6: Other variants

Supplementary designations

Prefixes

Prefixes are used to identify components of a bearing and are usually then followed by the designation of the complete bearing, or to avoid confusion with other bearing designations. For example they are used in front of designations for taper roller bearings according to a system described in ANSI/ ABMA Standard 19 for (predominantly) inch bearings.

GS	Housing washer of a cylindrical roller thrust bearing
K	Cylindrical roller and cage thrust assembly
K-	Inner ring with roller and cage assembly (cone) or outer ring (cup) of inch taper roller bearing belonging to an ABMA standard series
L	Separate inner or outer ring of a separable bearing
R	Inner or outer ring with roller (and cage) assembly of a separable bearing
W	Stainless steel deep groove ball bearing
WS	Shaft washer of a cylindrical roller thrust bearing
ZE	Bearing with SensorMount® feature

Suffixes

Suffixes are used to identify designs or variants which differ in some way from the original design, or which differ from the current standard design. The suffixes are divided into groups and when more than one special feature is to be identified; suffixes are provided in the order shown in the scheme in **diagram 4**.

The most commonly used suffixes are listed below. Note that not all variants are available.

A	Deviating or modified internal design with the same boundary dimensions. As a rule the significance of the letter is bound to the particular bearing or bearing series. Examples: 4210 A: Double row deep groove ball bearing without filling slots 3220 A: Double row angular contact ball bearing without filling slots
AC	Single row angular contact ball bearing with a 25° contact angle
ADA	Modified snap ring grooves in the outer ring; a two-piece inner ring held together by a retaining ring
B	Deviating or modified internal design with the same boundary dimensions. As a rule the significance of the letter is bound to the particular bearing series. Examples: 7224 B: Single row angular contact ball bearing with a 40° contact angle 32210 B: Steep contact angle taper roller bearing
Bxx(x)	B combined with a two or three-figure number identifies variants of the standard design that cannot be identified by generally applicable suffixes. Example: B20: Reduced width tolerance
C	Deviating or modified internal design with the same boundary dimensions. As a rule the significance of the letter is bound to the particular bearing series. Example: 21306 C: Spherical roller bearing with a flangeless inner ring, symmetrical rollers, loose guide ring and a pressed window-type steel cage

Bearing data – general

CA	<ol style="list-style-type: none"> 1. Spherical roller bearing of C design, but with retaining flanges on the inner ring and a machined cage 2. Single row angular contact ball bearing for universal matching. Two bearings arranged back-to-back or face-to-face will have an axial internal clearance smaller than Normal (CB) before mounting 	CN	<p>Normal internal clearance, normally only used together with an additional letter that identifies a reduced or displaced clearance range. Examples:</p> <p>CNH Upper half of the Normal clearance range</p> <p>CNL Lower half of the Normal clearance range</p> <p>CNM Two middle quarters of the Normal clearance range</p> <p>CNP Upper half of the Normal and lower half of C3 clearance</p> <p>The above letters H, L, M and P are also used together with the clearance classes C2, C3, C4 and C5</p>
CAC	Spherical roller bearing of the CA design but with enhanced roller guidance	CV	Full complement cylindrical roller bearing with modified internal design
CB	<ol style="list-style-type: none"> 1. Single row angular contact ball bearing for universal matching. Two bearings arranged back-to-back or face-to-face will have a Normal axial internal clearance before mounting 2. Controlled axial clearance of a double row angular contact ball bearing 	CS	Sheet steel reinforced contact seal of acrylonitrile-butadiene rubber (NBR) on one side of the bearing
CC	<ol style="list-style-type: none"> 1. Spherical roller bearing of C design but with enhanced roller guidance 2. Single row angular contact ball bearing for universal matching. Two bearings arranged back-to-back or face-to-face will have an axial internal clearance larger than Normal (CB) before mounting 	2CS	CS contact seal on both sides of the bearing
CLN	Taper roller bearing with tolerances corresponding to ISO tolerance class 6X	CS2	Sheet steel reinforced contact seal of fluoro rubber (FKM) on one side of the bearing
CLO	Inch taper roller bearing with tolerances to class 0 according to ANSI/ABMA Standard 19.2:1994	2CS2	CS2 contact seal on both sides of the bearing
CL00	Inch taper roller bearing with tolerances to class 00 according to ANSI/ABMA Standard 19.2:1994	CS5	Sheet steel reinforced contact seal of hydrogenated acrylonitrile-butadiene rubber (HNBR) on one side of the bearing
CL3	Inch taper roller bearing with tolerances to class 3 according to ANSI/ABMA Standard 19.2:1994	2CS5	CS5 contact seal on both sides of the bearing
CL7C	Taper roller bearing with special frictional behaviour and heightened running accuracy	C1	Bearing internal clearance smaller than C2
		C2	Bearing internal clearance smaller than Normal (CN)
		C3	Bearing internal clearance greater than Normal (CN)
		C4	Bearing internal clearance greater than C3
		C5	Bearing internal clearance greater than C4
		C02	Extra reduced tolerance for running accuracy of inner ring of assembled bearing
		C04	Extra reduced tolerance for running accuracy of outer ring of assembled bearing
		C08	C02 + C04
		C083	C02 + C04 + C3

- C10** Reduced tolerance for the bore and outside diameters
- D** Deviating or modified internal design with the same boundary dimensions; as a rule the significance of the letter is bound to the particular bearing series.
Example:
3310 D: Double row angular contact ball bearing with a two-piece inner ring
- DA** Modified snap ring grooves in the outer ring; two-piece inner ring held together by a retaining ring
- DB** Two single row deep groove ball bearings (1), single row angular contact ball bearings (2) or single row taper roller bearings matched for mounting in a back-to-back arrangement. The letter(s) following the DB indicate the magnitude of the axial internal clearance or preload in the bearing pair before mounting.
- A Light preload (2)
 - B Moderate preload (2)
 - C Heavy preload (2)
 - CA Axial internal clearance smaller than Normal (CB) (1, 2)
 - CB Normal axial internal clearance (1, 2)
 - CC Axial internal clearance larger than Normal (CB) (1, 2)
 - C Special axial internal clearance in μm
 - GA Light preload (1)
 - GB Moderate preload (1)
 - G Special preload in daN
- For paired taper roller bearings the design and arrangement of the intermediate rings between the inner and outer rings are identified by a two-figure number which is placed between DB and the above mentioned letters.
- DF** Two single row deep groove ball bearings, single row angular contact ball bearings or single row taper roller bearings matched for mounting in a face-to-face arrangement. The letter(s) following the DF are explained under DB
- DT** Two single row deep groove ball bearings, single row angular contact ball bearings or single row taper roller bearings matched for mounting in a tandem arrangement; for paired taper roller bearings the design and arrangement of the intermediate rings between the inner and/or outer rings are identified by a two-figure number which follows immediately after DT
- E** Deviating or modified internal design with the same boundary dimensions; as a rule the significance of the letter is bound to the particular bearing series; usually indicates reinforced rolling element complement. Example:
7212 BE: Single row angular contact ball bearing with a 40° contact angle and optimized internal design
- EC** Single row cylindrical roller bearing with an optimized internal design and with modified roller end/flange contact
- ECA** Spherical roller bearing of CA design but with reinforced rolling element complement
- ECAC** Spherical roller bearing of CAC design but with reinforced rolling element complement
- F** Machined steel or special cast iron cage, rolling element centred; different designs or material grades are identified by a figure following the F, e.g. F1
- FA** Machined steel or special cast iron cage; outer ring centred
- FB** Machined steel or special cast iron cage; inner ring centred
- G** Single row angular contact ball bearing for universal matching. Two bearings arranged back-to-back or face-to-face will have a certain axial clearance before mounting

Bearing data – general

G..	Grease filling. A second letter indicates the temperature range of the grease and a third letter identifies the actual grease. The significance of the second letter is as follows: E Extreme pressure grease F Food compatible grease H, J High temperature grease, e.g. –20 to +130 °C L Low temperature grease, e.g. –50 to +80 °C M Medium temperature grease, e.g. –30 to +110 °C W, X Low/high temperature grease, e.g. –40 to +140 °C A figure following the three-letter grease code indicates that the filling degree deviates from the standard: Figures 1, 2 and 3 indicate smaller than standard, 4 up to 9 a larger fill. Examples: GEA: Extreme pressure grease, standard fill GLB2: Low temperature grease, 15 to 25 % fill	HA	Case-hardened bearing or bearing components. For closer identification HA is followed by one of the following figures: 0 Complete bearing 1 Outer and inner rings 2 Outer ring 3 Inner ring 4 Outer ring, inner ring and rolling elements 5 Rolling elements 6 Outer ring and rolling elements 7 Inner ring and rolling elements
GA	Single row angular contact ball bearing for universal matching. Two bearings arranged back-to-back or face-to-face will have a light preload before mounting	HB	Bainite-hardened bearing or bearing components. For closer identification HB is followed by one of the figures explained under HA
GB	Single row angular contact ball bearing for universal matching. Two bearings arranged back-to-back or face-to-face will have a moderate preload before mounting	HC	Bearing or bearing components of ceramic material. For closer identification HC is followed by one of the figures explained under HA
GC	Single row angular contact ball bearing for universal matching. Two bearings arranged back-to-back or face-to-face will have a heavy preload before mounting	HE	Bearing or bearing components of vacuum remelted steel. For closer identification HE is followed by one of the figures explained under HA
GJN	Grease with a polyurea thickener of consistency 2 to the NLGI Scale for a temperature range –30 to +150 °C (normal fill grade)	HM	Martensite-hardened bearing or bearing components. For closer identification HM is followed by one of the figures explained under HA
GXN	Grease with a polyurea thickener of consistency 2 to the NLGI Scale for a temperature range –40 to +150 °C (normal fill grade)	HN	Special surface heat-treated bearing or bearing components. For closer identification HN is followed by one of the figures explained under HA
H	Pressed snap-type steel cage, hardened	HT	Grease fill for high temperatures (e.g. –20 to +130 °C). HT or a two-figure number following HT identifies the actual grease. Filling degrees other than standard are identified by a letter or letter/figure combination following HTxx: A Filling degree less than standard B Filling degree greater than standard C Filling degree greater than 70 % F1 Filling degree less than standard F7 Filling degree greater than standard F9 Filling degree greater than 70 % Examples: HTB, HT22 or HT24B
		HV	Bearing or bearing components of hardenable stainless steel. For closer identification HV is followed by one of the figures explained under HA
		J	Pressed steel cage, rolling element centred, unhardened; different designs are identified by a figure, e.g. J1

JR	Cage comprising of two flat washers of unhardened steel, riveted together	N	Snap ring groove in the outer ring
K	Tapered bore, taper 1:12	NR	Snap ring groove in the outer ring with appropriate snap ring
K30	Tapered bore, taper 1:30	N1	One locating slot (notch) in one outer ring side face or housing washer
LHT	Grease fill for low and high temperatures (e.g. -40 to +140 °C). A two-figure number following LHT identifies the actual grease. An additional letter or letter/figure combination as mentioned under "HT" identifies filling degrees other than standard. Examples: LHT23, LHT23C or LHT23F7	N2	Two locating slots (notches) 180° apart in one outer ring side face or housing washer
LS	Contact seal of acrylonitrile-butadiene rubber (NBR) or polyurethane (AU) with or without sheet steel reinforcement, on one side of the bearing	P	Injection moulded cage of glass fibre reinforced polyamide 6,6, rolling element centred
2LS	LS contact seal on both sides of the bearing	PH	Injection moulded cage of polyether-etherketone (PEEK), rolling element centred
LT	Grease fill for low temperatures (e.g. -50 to +80 °C). LT or a two-figure number following LT identifies the actual grease. An additional letter or letter/figure combination as mentioned under "HT" identifies filling degrees other than standard. Examples: LT, LT10 or LTF1	PHA	Injection moulded cage of polyether-etherketone (PEEK), outer ring centred
L4B	Bearing rings and rolling elements with special surface coating	PHAS	Injection moulded cage of polyether-etherketone (PEEK), outer ring centred, lubrication grooves in the guiding surfaces
L5B	Rolling elements with special surface coating	P4	Dimensional and running accuracy to ISO tolerance class 4
L5DA	NoWear bearing with coated rolling elements	P5	Dimensional and running accuracy to ISO tolerance class 5
L7DA	NoWear bearing with coated rolling elements and inner ring raceway(s)	P6	Dimensional and running accuracy to ISO tolerance class 6
M	Machined brass cage, rolling element centred; different designs or material grades are identified by a figure or a letter, e.g. M2, MC	P62	P6 + C2
MA	Machined brass cage, outer ring centred	P63	P6 + C3
MB	Machined brass cage, inner ring centred	Q	Optimized internal geometry and surface finish (taper roller bearing)
ML	Machined one-piece window-type brass cage, inner or outer ring centred	R	1. Integral external outer ring flange 2. Crowned runner surface (track runner bearing)
MP	Machined one-piece window-type brass cage, with punched or reamed pockets, inner or outer ring centred	RS	Contact seal of acrylonitrile-butadiene rubber (NBR) with or without sheet steel reinforcement on one side of the bearing
MR	Machined one-piece window-type brass cage, rolling element centred	2RS	RS contact seal on both sides of the bearing
MT	Grease fill for medium temperatures (e.g. -30 to +110 °C). A two-figure number following MT identifies the actual grease. An additional letter or letter/figure combination as mentioned under "HT" identifies filling degrees other than standard. Examples: MT33, MT37F9 or MT47	RS1	Sheet steel reinforced contact seal of acrylonitrile-butadiene rubber (NBR) on one side of the bearing
		2RS1	RS1 contact seal on both sides of the bearing
		RS1Z	Sheet steel reinforced contact seal of acrylonitrile-butadiene rubber (NBR) on one side and one shield on the other side of the bearing
		RS2	Sheet steel reinforced contact seal of fluoro rubber (FKM) on one side of the bearing
		2RS2	RS2 contact seal on both sides of the bearing

Bearing data – general

RSH	Sheet steel reinforced contact seal of acrylonitrile-butadiene rubber (NBR) on one side of the bearing	V...	V combined with a second letter, identifies a variant group, and followed by a three- or four-figure number denotes variants not covered by “standard” designation suffixes. Examples:
2RSH	RSH contact seal on both sides of the bearing		VA Application oriented variants
RSL	Sheet steel reinforced low-friction contact seal of acrylonitrile-butadiene rubber (NBR) on one side of the bearing		VB Boundary dimension deviations
2RSL	RSL low-friction contact seal on both sides of the bearing		VE External or internal deviations
RZ	Sheet steel reinforced low-friction seal of acrylonitrile-butadiene rubber (NBR) on one side of the bearing		VL Coatings
2RZ	RZ low-friction seal on both sides of the bearing		VQ Quality and tolerances other than standard
S0	Bearing rings or washers dimensionally stabilized for use at operating temperatures up to +150 °C		VS Clearance and preload
S1	Bearing rings or washers dimensionally stabilized for use at operating temperatures up to +200 °C		VT Lubrication
S2	Bearing rings or washers dimensionally stabilized for use at operating temperatures up to +250 °C		VU Miscellaneous applications
S3	Bearing rings or washers dimensionally stabilized for use at operating temperatures up to +300 °C	VA201	Bearing for high-temperature applications (e.g. kiln trucks)
S4	Bearing rings or washers dimensionally stabilized for use at operating temperatures up to +350 °C	VA208	Bearing for high-temperature applications
T	Window-type cage of fabric reinforced phenolic resin, rolling element centred	VA216	Bearing for high-temperature applications
TB	Window-type cage of fabric reinforced phenolic resin, inner ring centred	VA228	Bearing for high-temperature applications
TH	Snap-type cage of fabric reinforced phenolic resin, rolling element centred	VA301	Bearing for traction motors
TN	Injection moulded cage of polyamide 6,6, rolling element centred	VA305	Bearing for traction motors + special inspection routines
TNH	Injection moulded cage of polyether-etherketone (PEEK), rolling element centred	VA3091	Bearing for traction motors with aluminium oxide coated outside surface of outer ring for electrical resistance up to 1 000 V DC
TNHA	Injection moulded cage of polyether-etherketone (PEEK), outer ring centred	VA320	Bearing for railway axleboxes according to EN 12080:1998
TN9	Injection moulded cage of glass fibre reinforced polyamide 6,6, rolling element centred	VA350	Bearing for railway axleboxes
U	U combined with a one-figure number identifies a taper roller bearing, cone or cup, with reduced width tolerance. Examples: U2: Width tolerance +0,05/0 mm U4: Width tolerance +0,10/0 mm	VA405	Bearing for vibratory applications
V	Full complement bearing (without cage)	VA406	Bearing for vibratory applications with special PTFE bore coating
		VC025	Bearing with specially debris-heat-treated components for applications in heavily contaminated environments
		VE240	CARB bearing modified for greater axial displacement
		VE447	Shaft washer with three equally spaced threaded holes in one side face to accommodate hoisting tackle
		VE552	Outer ring with three equally spaced threaded holes in one side face to accommodate hoisting tackle
		VE553	Outer ring with three equally spaced threaded holes in both side faces to accommodate hoisting tackle
		VE632	Housing washer with three equally spaced threaded holes in one side face to accommodate hoisting tackle
		VG114	Surface-hardened pressed steel cage

VH	Full complement cylindrical roller bearing with self-retaining roller set
VL0241	Aluminium oxide coated outside surface of outer ring for electrical resistance up to 1 000 V DC
VL2071	Aluminium oxide coated outside surface of inner ring for electrical resistance up to 1 000 V DC
VQ015	Inner ring with crowned raceway for increased permissible misalignment
VQ424	Running accuracy better than C08
VT143	Extreme pressure grease with a lithium thickener of consistency 2 to the NLGI Scale for a temperature range –20 to +110 °C (normal fill grade)
VT378	Food grade grease with an aluminium thickener of consistency 2 to the NLGI Scale for a temperature range –25 to +120 °C (normal fill grade)
W	Without annular groove and lubrication holes in outer ring
WT	Grease fill for low as well as high temperatures (e.g. –40 to +160 °C). WT or a two-figure number following WT identifies the actual grease. An additional letter or letter/figure combination as mentioned under “HT” identifies filling degrees other than standard. Examples: WT or WTF1
W20	Three lubrication holes in the outer ring
W26	Six lubrication holes in the inner ring
W33	Annular groove and three lubrication holes in the outer ring
W33X	Annular groove and six lubrication holes in the outer ring
W513	Six lubrication holes in the inner ring and annular groove and three lubrication holes in the outer ring
W64	Solid Oil filling
W77	Plugged W33 lubrication holes
X	1. Boundary dimensions altered to conform to ISO standards 2. Cylindrical runner surface (track runner bearing)
Y	Pressed brass cage, rolling element centred; different designs or material grades are identified by a figure following the Y, e.g. Y1
Z	Shield of pressed sheet steel on one side of the bearing
ZZ	Z-shield on both sides of the bearing

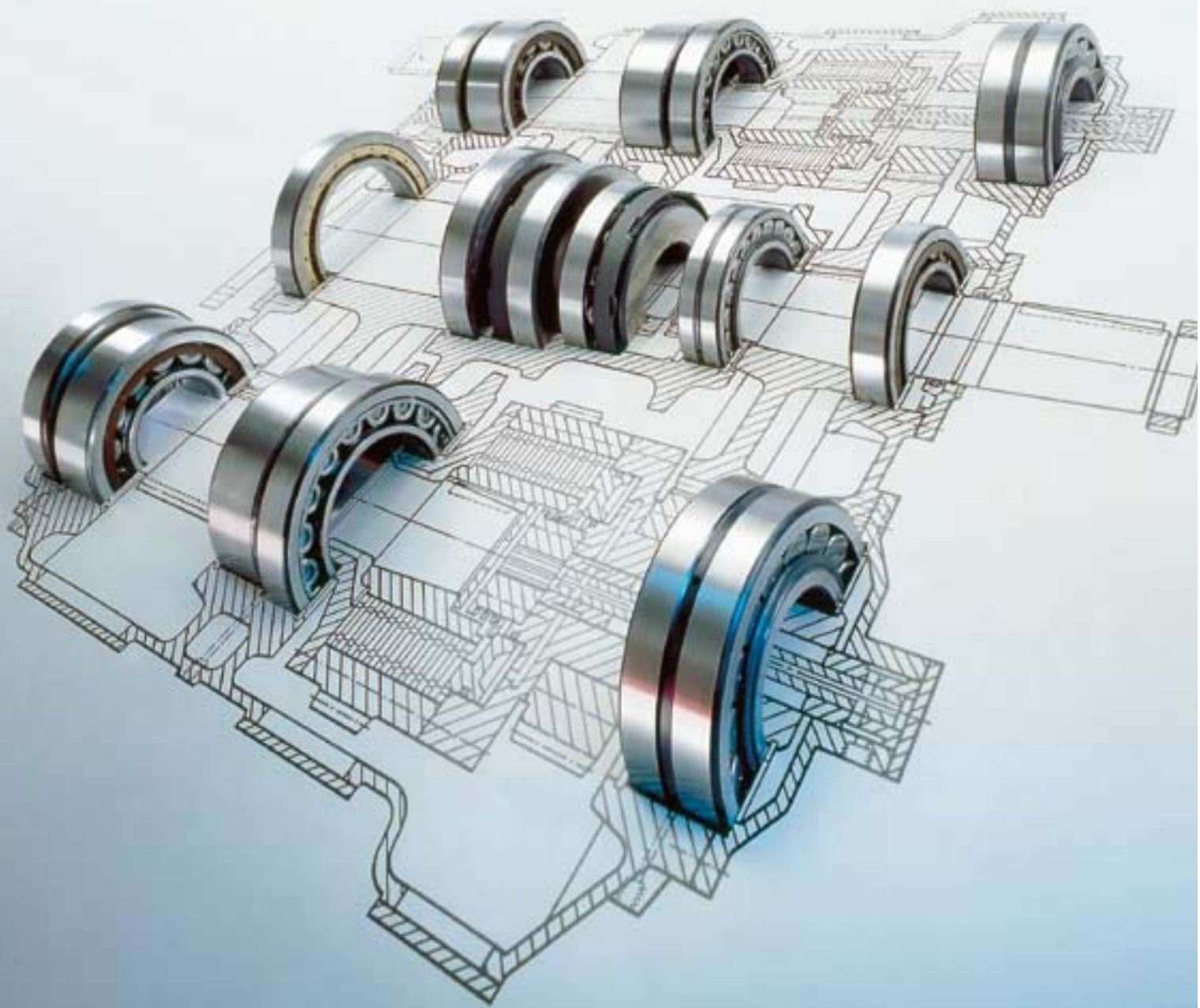

Application of bearings

Bearing arrangements.....	160
Locating and non-locating bearing arrangements	160
Adjusted bearing arrangements.....	162
“Floating” bearing arrangements.....	162
Radial location of bearings.....	164
Selection of fit.....	164
Recommended fits	167
Tables with recommendations for fits	168
Tolerance tables.....	172
Fits for hollow shafts	172
Dimensional, form and running accuracy of bearing seatings and abutments	194
Surface roughness of bearing seatings.....	198
Raceways on shafts and in housings.....	198
Axial location of bearings.....	199
Methods of location.....	199
Abutment and fillet dimensions.....	202
Designing associated components	204
Bearing preload	206
Types of preload	206
Effect of bearing preload.....	208
Determining preload force	208
Adjustment procedures.....	212
Preloading by springs.....	216
Maintaining the correct preload	216
Bearings for preloaded bearing arrangements	217
Sealing arrangements	218
Types of seals.....	218
Selection of seal type	219
Integral bearing seals.....	221
External seals	223

Bearing arrangements

The bearing arrangement of a rotating machine component, e.g. a shaft, generally requires two bearings to support and locate the component radially and axially relative to the stationary part of the machine, such as a housing. Depending on the application, load, requisite running accuracy and cost considerations, the arrangement may consist of

- locating and non-locating bearing arrangements
- adjusted bearing arrangements
- “floating” bearing arrangements.

Bearing arrangements consisting of a single bearing that can support radial, axial and moment loads, e.g. for an articulated joint, are not dealt with in this catalogue. If such arrangements are required it is advisable to contact the SKF application engineering service.

Locating and non-locating bearing arrangements

The locating bearing at one end of the shaft provides radial support and at the same time locates the shaft axially in both directions. It must, therefore, be fixed in position both on the shaft and in the housing. Suitable bearings are radial bearings which can accommodate combined loads, e.g. deep groove ball bearings, double row or paired single row angular contact ball bearings, self-aligning ball bearings, spherical roller bearings or matched taper roller bearings. Combinations of a radial bearing that can accommodate purely radial load, e.g. a cylindrical roller bearing having one ring without flanges, with a deep groove ball bearing, four-point contact ball bearing or a double direction thrust bearing can also be used as the locating bearing. The second bearing then provides axial location in both directions but must be mounted with radial freedom (i.e. have a clearance fit) in the housing.

The non-locating bearing at the other end of the shaft provides radial support only. It must also enable axial displacement so that the bearings do not mutually stress each other, e.g. when the shaft length changes as a result of thermal expansion. Axial displacement can take place within the bearing in the case of needle

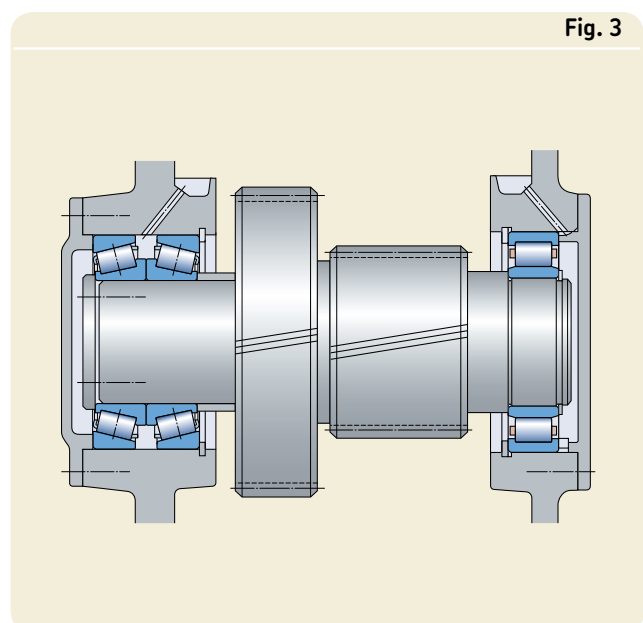
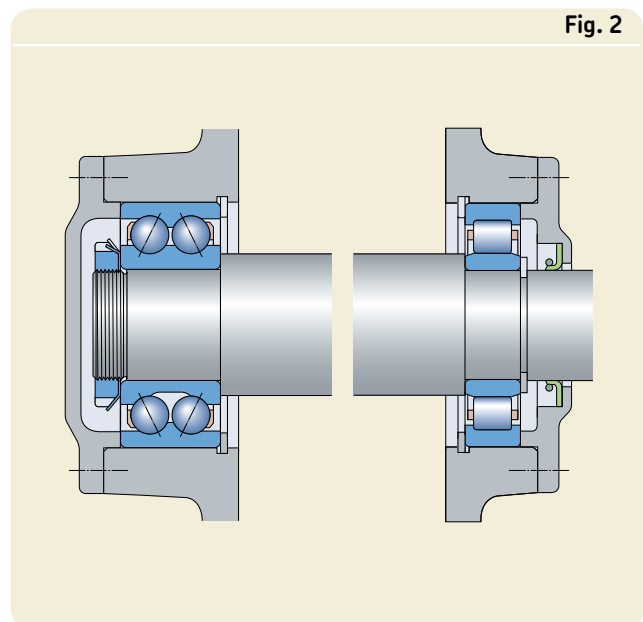
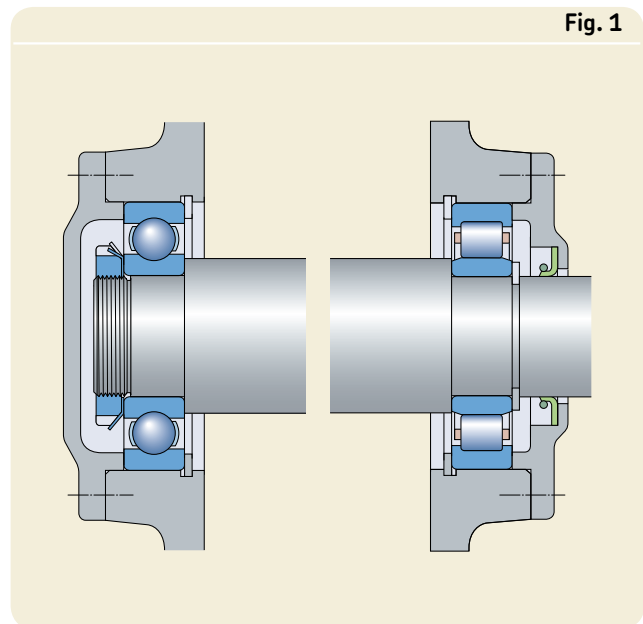

Fig. 4

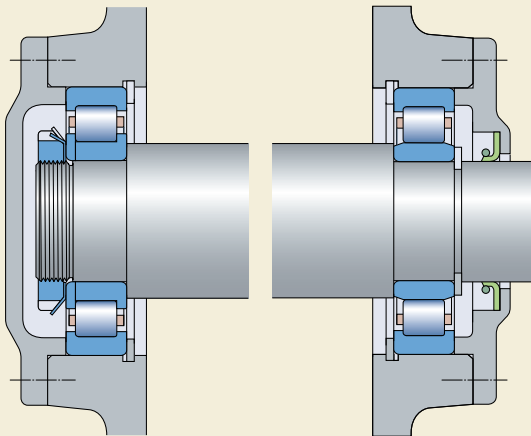

Fig. 5

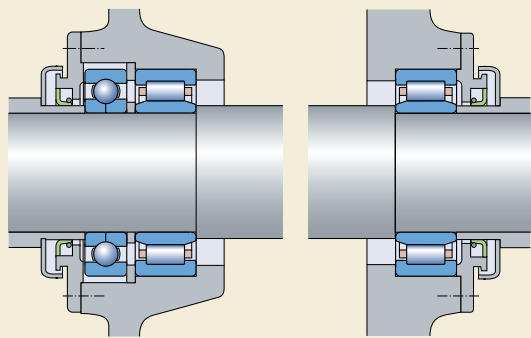
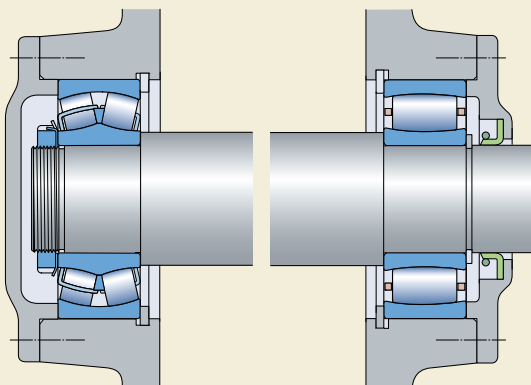

Fig. 6



roller bearings, NU and N design cylindrical roller bearings and CARB toroidal roller bearings, or between one of the bearing rings and its seating, preferably between the outer ring and its seating in the housing bore.

From the large number of locating/non-locating bearing combinations the popular combinations are described in the following.

For stiff bearing arrangements where “frictionless” axial displacements should take place within the bearing the following combinations may be used

- deep groove ball bearing/cylindrical roller bearing (→ **fig. 1**)
- double row angular contact ball bearing/cylindrical roller bearing (→ **fig. 2**)
- matched single row taper roller bearings/cylindrical roller bearing (→ **fig. 3**)
- NUP design cylindrical roller bearing/NU design cylindrical roller bearing (→ **fig. 4**)
- NU design cylindrical roller bearing and four-point contact ball bearing/NU design cylindrical roller bearing (→ **fig. 5**).

For the above combinations, angular misalignment of the shaft must be kept to a minimum. If this is not possible it is advisable to use combinations of self-aligning bearings to enable misalignment, viz.

- self-aligning ball bearing/CARB toroidal roller bearing or
- spherical roller bearing/CARB toroidal roller bearing (→ **fig. 6**).

The ability of these arrangements to accommodate angular misalignments as well as axial displacements avoids generating internal axial forces in the bearing system.

Application of bearings

For bearing arrangements with rotating inner ring load, where changes in the shaft length are to be accommodated between the bearing and its seating, axial displacement should take place between the outer ring of the bearing and the housing. The most usual combinations are

- deep groove ball bearing/deep groove ball bearing (→ **fig. 7**)
- self-aligning ball or spherical roller bearing/self-aligning ball or spherical roller bearing (→ **fig. 8**)
- matched single row angular contact ball bearings/deep groove ball bearing (→ **fig. 9**).

Adjusted bearing arrangements

In adjusted bearing arrangements the shaft is axially located in one direction by the one bearing and in the opposite direction by the other bearing. This type of arrangement is referred to as “cross located” and is generally used for short shafts. Suitable bearings include all types of radial bearings that can accommodate axial loads in at least one direction, including

- angular contact ball bearings (→ **fig. 10**)
- taper roller bearings (→ **fig. 11**).

In certain cases where single row angular contact ball bearings or taper roller bearings are used for cross-located arrangements, preload may be necessary (→ **page 206**).

“Floating” bearing arrangements

Floating bearing arrangements are also cross located and are suitable where demands regarding axial location are moderate or where other components on the shaft serve to locate it axially.

Suitable bearings for this type of arrangement are

- deep groove ball bearings (→ **fig. 12**)
- self-aligning ball bearings
- spherical roller bearings.

In these types of arrangements it is important that one ring of each bearing should be able to move on or in its seating, preferably the outer ring in the housing. A floating bearing arrangement can also be obtained with two NJ design cylindrical roller bearings, with offset inner rings (→ **fig. 13**). In this case the axial movement can take place within the bearing.

Fig. 7

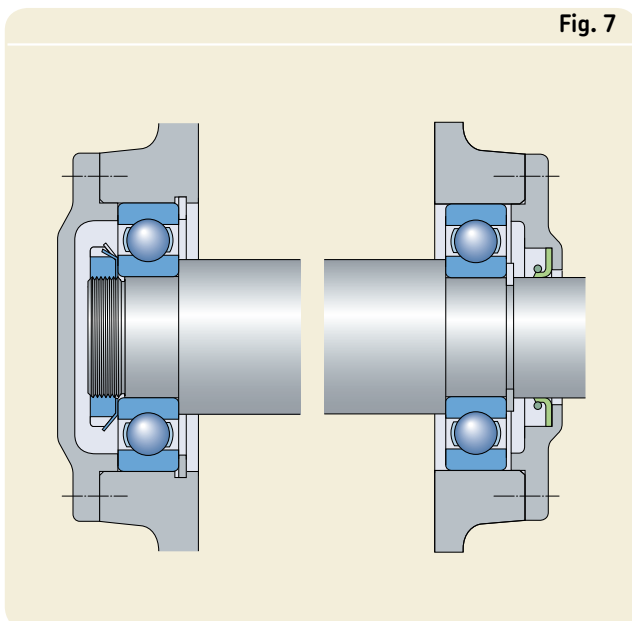

Fig. 8

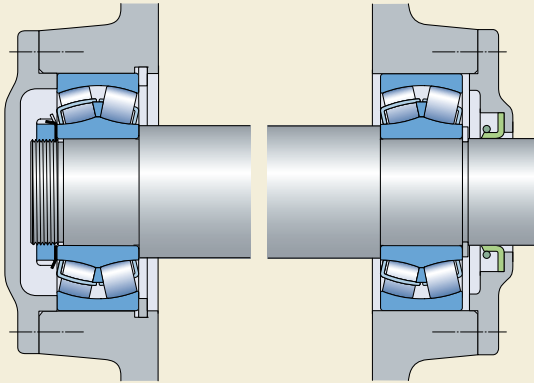

Fig. 11

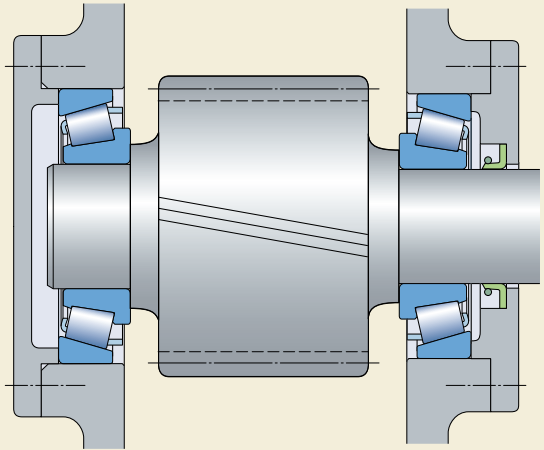

Fig. 9

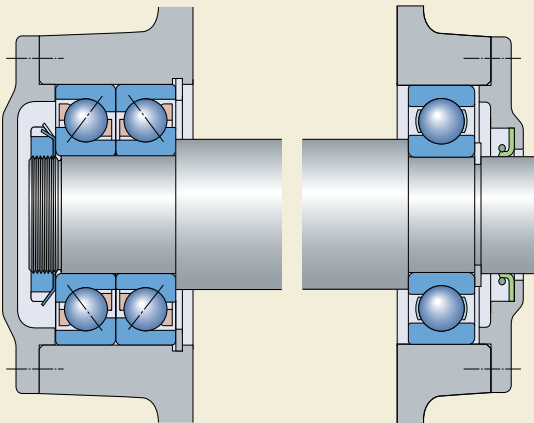

Fig. 12

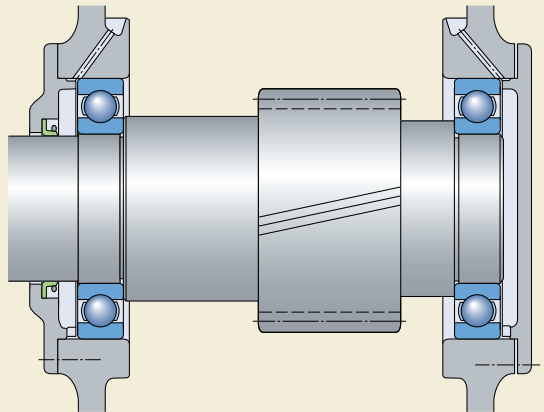

Fig. 10

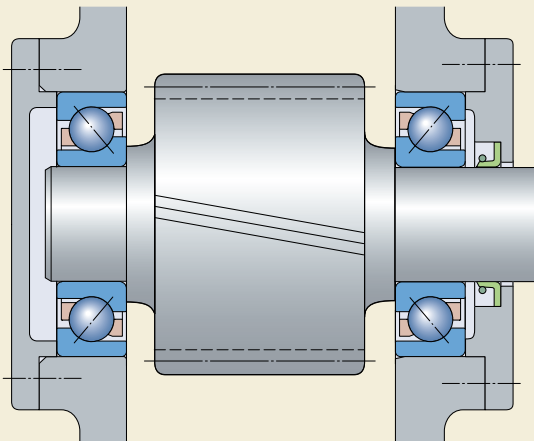
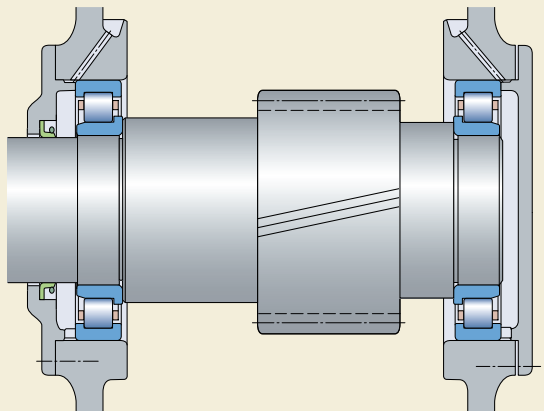

Fig. 13



Radial location of bearings

If the load carrying ability of a bearing is to be fully utilized, its rings or washers must be fully supported around their complete circumference and across the entire width of the raceway. The support, which must be firm and even can be provided by a cylindrical or tapered seating or, for thrust bearing washers, by a flat (plane) support surface. This means that bearing seatings must be made with adequate accuracy and that their surface should be uninterrupted by grooves, holes or other features. In addition, the bearing rings must be reliably secured to prevent them from turning on or in their seatings under load.

Generally speaking, satisfactory radial location and adequate support can only be obtained when the rings are mounted with an appropriate degree of interference. Inadequately or incorrectly secured bearing rings generally cause damage to the bearings and associated components. However, when easy mounting and dismounting are desirable, or when axial displacement is required with a non-locating bearing, an interference fit cannot always be used. In certain cases where a loose fit is employed it is necessary to take special precautions to limit the inevitable wear from creep, as for example, by surface hardening of the bearing seating and abutments, lubrication of the mating surfaces via special lubrication grooves and the removal of wear particles, or slots in the bearing ring side faces to accommodate keys or other holding devices.

Selection of fit

When selecting a fit, the factors discussed in this section should be considered, together with the general guidelines provided.

1. Conditions of rotation

Conditions of rotation refer to the bearing ring being considered in relation to the direction of the load (→ **table 1**). Essentially, there are three different conditions: “rotating load”, “stationary load” and “direction of load indeterminate”.

“Rotating load” pertains if the bearing ring rotates and the load is stationary, or if the ring is stationary and the load rotates so that all points on the raceway are subjected to load in the course of one revolution. Heavy loads which

do not rotate but oscillate, for example, those acting on connecting rod bearings, are generally considered as rotating loads.

A bearing ring subjected to a rotating load will turn (creep or wander) on its seating if mounted with a clearance fit, and wear (fretting corrosion) of the contact surfaces will result. To prevent this, interference fits must be used. The degree of interference needed is dictated by the operating conditions (→ **points 2 and 4** below).

“Stationary load” pertains if the bearing ring is stationary and the load is also stationary, or if the ring and the load rotate at the same speed, so that the load is always directed towards the same position on the raceway. Under these conditions, a bearing ring will normally not turn on its seating. Therefore, the ring need not necessarily have an interference fit, unless this is required for other reasons.

“Direction of load indeterminate” represents variable external loads, shock loads, vibrations and unbalance loads in high-speed machines. These give rise to changes in the direction of load, which cannot be accurately described. When the direction of load is indeterminate and particularly where heavy loads are involved, it is desirable that both rings have an interference fit. For the inner ring the recommended fit for a rotating load is normally used. However, when the outer ring must be free to move axially in the housing, and the load is not heavy, a somewhat looser fit than that recommended for a rotating load may be used.

2. Magnitude of the load

The interference fit of a bearing inner ring on its seating will be loosened with increasing load, as the ring will deform. Under the influence of rotating load the ring may begin to creep. The degree of interference must therefore be related to the magnitude of the load; the heavier the load, the greater the interference fit required (→ fig. 14). Shock loads and vibration also need to be considered.

Magnitude of load is defined as

- $P \leq 0,05 C$ – light load
- $0,05 C < P \leq 0,1 C$ – normal load
- $0,1 C < P \leq 0,15 C$ – heavy load
- $P > 0,15 C$ – very heavy load.

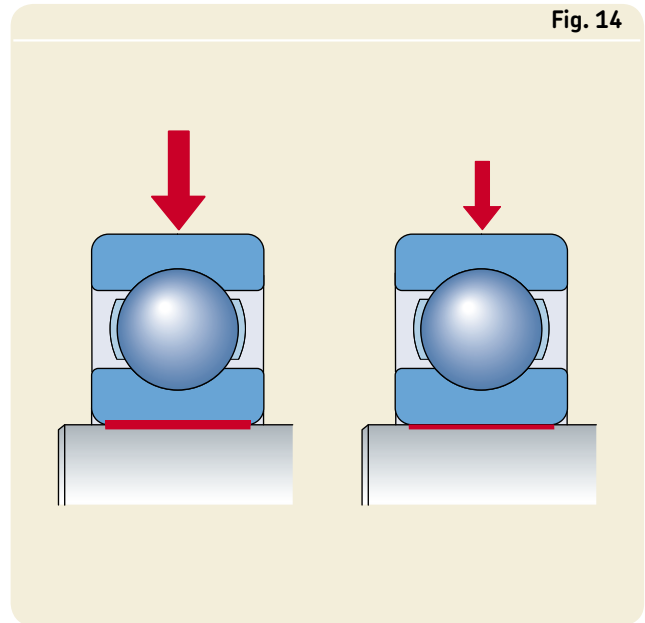

Table 1

Conditions of rotation and loading				
Operating conditions	Schematic illustration	Load condition	Example	Recommended fits
Rotating inner ring Stationary outer ring Constant load direction		Rotating load on inner ring Stationary load on outer ring	Belt-driven shafts	Interference fit for inner ring Loose fit for outer ring
Stationary inner ring Rotating outer ring Constant load direction		Stationary load on inner ring Rotating load on outer ring	Conveyor idlers Car wheel hub bearings	Loose fit for inner ring Interference fit for outer ring
Rotating inner ring Stationary outer ring Load rotates with inner ring		Stationary load on inner ring Rotating load on outer ring	Vibratory applications Vibrating screens or motors	Interference fit for outer ring Loose fit for inner ring
Stationary inner ring Rotating outer ring Load rotates with outer ring		Rotating load on inner ring. Stationary load on outer ring	Gyratory crusher (Merry-go-round drives)	Interference fit for inner ring Loose fit for outer ring

Application of bearings

3. Bearing internal clearance

An interference fit of a bearing on a shaft or in a housing means that the ring is elastically deformed (expanded or compressed) and that the bearing internal clearance is reduced. A certain minimum clearance should remain, however (→ section “Bearing internal clearance” on **page 137**). The initial clearance and permissible reduction depend on the type and size of the bearing. The reduction in clearance due to the interference fit can be so large that bearings with an initial clearance, which is greater than Normal, have to be used in order to prevent the bearing from becoming preloaded (→ **fig. 15**).

4. Temperature conditions

In many applications the outer ring has a lower temperature in operation than the inner ring. This might lead to reduced internal clearance (→ **fig. 16**).

In service, bearing rings normally reach a temperature that is higher than that of the components to which they are fitted. This can result in an easing of the fit of the inner ring on its seating, while outer ring expansion may prevent the desired axial displacement of the ring in its housing. Fast starting up or seal friction might also lead to easing of the inner ring fit.

Temperature differentials and the direction of heat flow in the bearing arrangement must therefore be carefully considered.

5. Running accuracy requirements

To reduce resilience and vibration, clearance fits should generally not be used for bearings where high demands are placed on running accuracy. Bearing seatings on the shaft and in the housing should be made to narrow dimensional tolerances, corresponding at least to grade 5 for the shaft and at least to grade 6 for the housing. Tight tolerances should also be applied to the cylindricity (→ **table 11, page 196**).

6. Design and material of shaft and housing

The fit of a bearing ring on its seating must not lead to uneven distortion of the ring (out-of-round). This can be caused, for example, by discontinuities in the seating surface. Split housings are therefore not generally suitable where outer rings are to have a heavy interference fit and the selected tolerance should not give a tighter fit than that obtained with tolerance group H (or at the most K). To provide adequate

Fig. 15

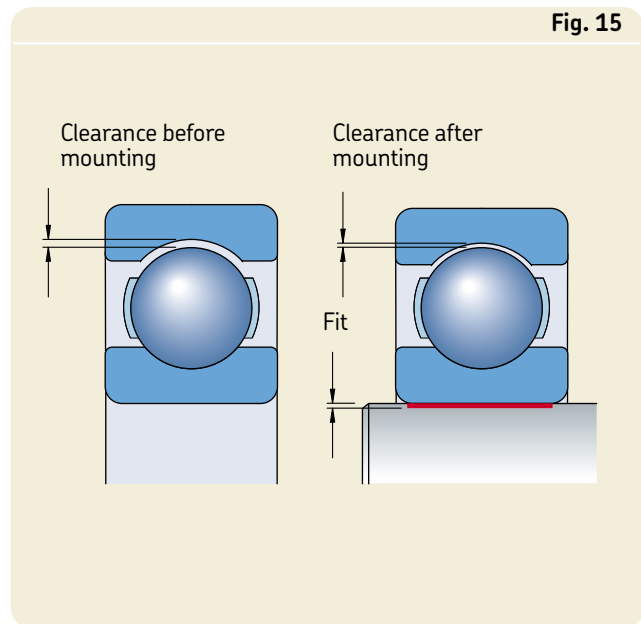
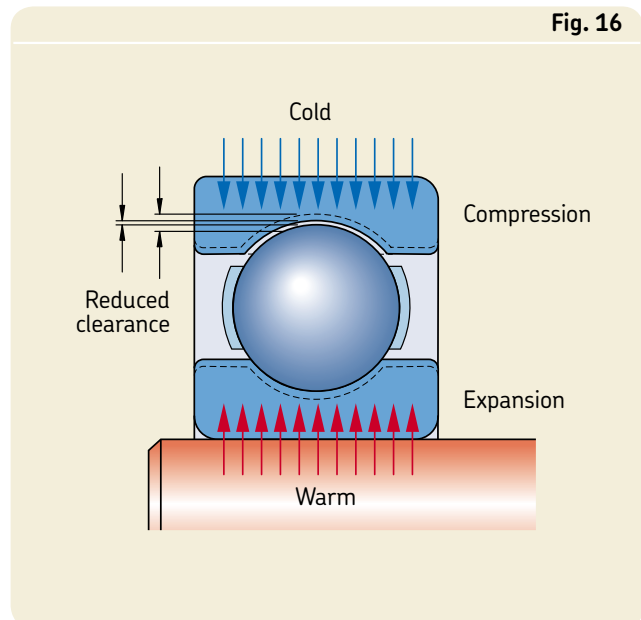

Fig. 16



support for bearing rings mounted in thin-walled housings, light alloy housings or on hollow shafts, heavier interference fits than those normally recommended for thick-walled steel or cast iron housings or for solid shafts should be used (→ section “Fits for hollow shafts”, starting on **page 172**). Also, sometimes lighter interference fits may be required for certain shaft materials.

7. Ease of mounting and dismounting

Bearings with clearance fits are usually easier to mount or dismount than those with interference fits. Where operating conditions necessitate interference fits and it is essential that mounting and dismounting can be done easily, separable bearings, or bearings with a tapered bore may be used. Bearings with a tapered bore can be mounted either directly on a tapered shaft seating or via adapter or withdrawal sleeves on smooth or stepped cylindrical shafts (→ **figs. 26, 27 and 28, page 201**).

8. Displacement of the non-locating bearing

If bearings that cannot accommodate axial displacement within the bearing are used in the non-locating position, it is imperative that one of the bearing rings is free to move axially at all times. Adopting a clearance fit for the ring that carries a stationary load will provide this (→ **fig. 20, page 199**). When the outer ring is under stationary load so that axial displacement is accommodated or takes place in the housing bore, a hardened intermediate bushing or sleeve is often fitted to the outer ring, for example, where light alloy housings are employed. In this way a “hammering out” of the housing seating because of the lower material hardness is avoided; it would otherwise result in the axial displacement being restricted or even prohibited over time.

If cylindrical roller bearings having one ring without flanges, needle roller bearings or CARB toroidal roller bearings are used, both bearing rings may be mounted with an interference fit because axial displacement will take place within the bearing.

Recommended fits

The tolerances for the bore and outside diameters of rolling bearings are internationally standardized (→ section “Tolerances”, starting on **page 120**).

To achieve an interference or a clearance fit for bearings with a cylindrical bore and cylindrical outside diameter, suitable tolerance ranges for the seatings on the shaft and in the housing bore are selected from the ISO tolerance system. Only a limited number of ISO tolerance grades need be considered for rolling bearing applications. The location of the most commonly used grades relative to the bearing bore and outside diameter tolerances are illustrated in **fig. 17, page 168**.

Bearings with a tapered bore are mounted either directly on tapered shaft seatings or on adapter or withdrawal sleeves, having an external taper, which are fitted to cylindrical shaft seatings. In these cases, the fit of the bearing inner ring is not determined, as for bearings with a cylindrical bore, by the selected shaft tolerance but by the distance through which the ring is driven up on its tapered seating or sleeve. Special precautions with respect to the reduction of the internal clearance must be observed as mentioned in the sections “Self-aligning ball bearings”, “Spherical roller bearings” and “CARB toroidal roller bearings”.

If the bearings are to be secured using adapter or withdrawal sleeves, larger diameter tolerances are permitted for the sleeve seating, but the tolerances for cylindricity must be tighter (→ section “Dimensional, form and running accuracy of bearing seatings and abutments”, starting on **page 194**).

Application of bearings

Tables with recommendations for fits

Recommendations for bearing fits for solid steel shafts can be found in

Table 2: Radial bearings with cylindrical bore

Table 3: Thrust bearings

and for cast iron and steel housings in

Table 4: Radial bearings – non-split housings

Table 5: Radial bearings – split or non-split housings

Table 6: Thrust bearings

These recommendations for modern bearings are based on the general selection guidelines described above, developments in bearing design and years of experience for a very wide range of bearing arrangements and applications. Modern bearings can carry substantially greater loads than previous conventional bearings and the recommendations reflect these more demanding conditions. The tables of hous-

ing tolerance recommendations also provide information as to whether the outer ring can be axially displaced in the housing bore. Using this information it is possible to check whether the chosen tolerance is suitable for non-separable bearings that are to be used in the non-locating position and cannot accommodate axial displacement within the bearing.

Note

For applications with stainless steel bearings, the recommended tolerances in **tables 2 to 6** on **pages 169 to 171** apply, but the restrictions in the footnotes ²⁾ and ³⁾ in **table 2** shall be taken into account. The footnote ¹⁾ in **table 2** is not valid for stainless steel bearings. If tighter fits than those recommended in **table 2** are needed, please contact the SKF application engineering service. It also may be necessary to consider the initial bearing clearance, e.g. when using stainless steel shafts at elevated temperatures.

Fig. 17

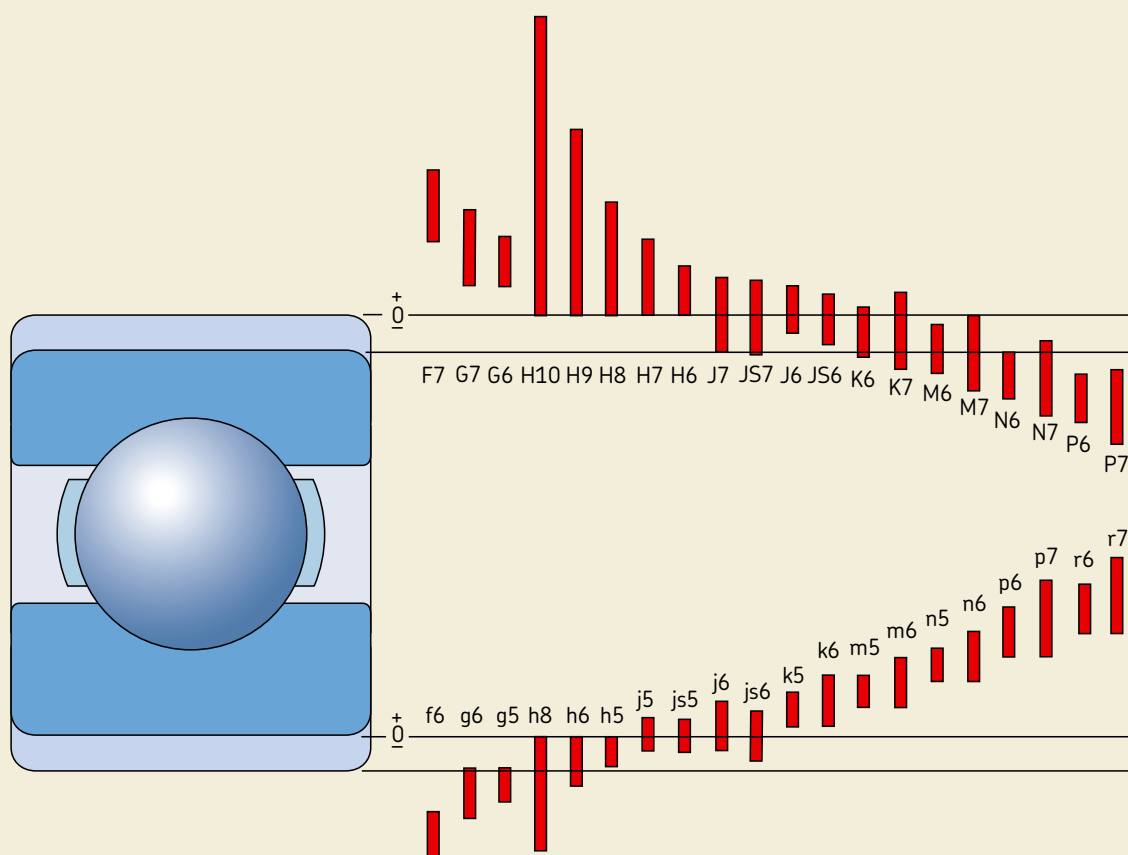

Table 2

Fits for solid steel shafts

Radial bearings with cylindrical bore

Conditions ¹⁾	Examples	Shaft diameter, mm				Tolerance
		Ball bearings ¹⁾	Cylindrical roller bearings	Taper roller bearings	CARB and spherical roller bearings	
Rotating inner ring load or direction of load indeterminate						
Light and variable loads (P ≤ 0,05 C)	Conveyors, lightly loaded gearbox bearings	≤ 17	–	–	–	js5 (h5) ²⁾
		(17) to 100	≤ 25	≤ 25	–	j6 (j5) ²⁾
Normal to heavy loads (P > 0,05 C)	Bearing applications generally, electric motors, turbines, pumps, gearing, wood-working machines, wind mills	(100) to 140	(25) to 60	(25) to 60	–	k6
		–	(60) to 140	(60) to 140	–	m6
		≤ 10	–	–	–	js5
		(10) to 17	–	–	–	j5 (j5) ²⁾
		(17) to 100	–	–	< 25	k5 ³⁾
		–	≤ 30	≤ 40	–	k6
		(100) to 140	(30) to 50	(40) to 65	25 to 40	m5
		(140) to 200	–	–	–	m6
		–	(50) to 65	–	(40) to 60	n5 ⁴⁾
		(200) to 500	(65) to 100	(65) to 200	(60) to 100	n6 ⁴⁾
–	(100) to 280	(200) to 360	(100) to 200	p6 ⁵⁾		
> 500	–	–	–	p7 ⁴⁾		
–	(280) to 500	(360) to 500	(200) to 500	r6 ⁴⁾		
–	> 500	> 500	> 500	r7 ⁴⁾		
Heavy to very heavy loads and shock loads with difficult working conditions (P > 0,1 C)	Axleboxes for heavy railway vehicles, traction motors, rolling mills	–	(50) to 65	–	(50) to 70	n5 ⁴⁾
		–	(65) to 85	(50) to 110	–	n6 ⁴⁾
		–	(85) to 140	(110) to 200	(70) to 140	p6 ⁶⁾
		–	(140) to 300	(200) to 500	(140) to 280	r6 ⁷⁾
		–	(300) to 500	–	(280) to 400	s6 _{min} ± IT6/2 ⁶⁾⁸⁾
–	> 500	> 500	> 400	s7 _{min} ± IT7/2 ⁶⁾⁸⁾		
High demands on running accuracy with light loads (P ≤ 0,05 C)	Machine tools	8 to 240	–	–	–	js4
		–	25 to 40	25 to 40	–	js4 (j5) ⁹⁾
		–	(40) to 140	(40) to 140	–	k4 (k5) ⁹⁾
		–	(140) to 200	(140) to 200	–	m5
		–	(200) to 500	(200) to 500	–	n5
Stationary inner ring load						
Easy axial displacement of inner ring on shaft desirable	Wheels on non-rotating axles					g6 ¹⁰⁾
Easy axial displacement of inner ring on shaft unnecessary	Tension pulleys, rope sheaves					h6
Axial loads only						
	Bearing applications of all kinds	≤ 250	–	≤ 250	≤ 250	j6
		> 250	–	> 250	> 250	js6

1) For normally to heavily loaded ball bearings (P > 0,05 C), radial clearance greater than Normal is often needed when the shaft tolerances in the table above are used. Sometimes the working conditions require tighter fits to prevent ball bearing inner rings from turning (creeping) on the shaft. If proper clearance, mostly larger than Normal clearance is selected, the tolerances below can then be used

- k4 for shaft diameters 10 to 17 mm
- k5 for shaft diameters (17) to 25 mm
- m5 for shaft diameters (25) to 140 mm
- n6 for shaft diameters (140) to 300 mm
- p6 for shaft diameters (300) to 500 mm

For additional information please contact the SKF application engineering service

2) The tolerance in brackets applies to stainless steel bearings

3) For stainless steel bearings within the diameter range 17 to 30 mm, tolerance j5 applies

4) Bearings with radial internal clearance greater than Normal may be necessary

5) Bearings with radial internal clearance greater than Normal are recommended for d ≤ 150 mm. For d > 150 mm bearings with radial internal clearance greater than Normal may be necessary

6) Bearings with radial internal clearance greater than Normal are recommended

7) Bearings with radial internal clearance greater than Normal may be necessary. For cylindrical roller bearings radial internal clearance greater than Normal is recommended

8) For tolerance values please consult the SKF Interactive Engineering Catalogue online at www.skf.com or the SKF application engineering service

9) The tolerance in brackets apply to taper roller bearings. For lightly loaded taper roller bearings adjusted via the inner ring, js5 or js6 should be used

10) Tolerance f6 can be selected for large bearings to provide easy displacement

Application of bearings

Table 3

Fits for solid steel shafts		
Thrust bearings		
Conditions	Shaft diameter, mm	Tolerance
Axial loads only		
Thrust ball bearings	–	h6
Cylindrical roller thrust bearings	–	h6 (h8)
Cylindrical roller and cage thrust assemblies	–	h8
Combined radial and axial loads acting on spherical roller thrust bearings		
Stationary load on shaft washer	≤ 250	j6
	> 250	js6
Rotating load on shaft washer, or direction of load indeterminate	≤ 200	k6
	(200) to 400	m6
	> 400	n6

Table 4

Fits for cast iron and steel housings			
Radial bearings – non-split housings			
Conditions ¹⁾	Examples	Tolerance ¹⁾	Displacement of outer ring
Rotating outer ring load			
Heavy loads on bearings in thin-walled housings, heavy shock loads (P > 0,1 C)	Roller bearing wheel hubs, big-end bearings	P7	Cannot be displaced
Normal to heavy loads (P > 0,05 C)	Ball bearing wheel hubs, big-end bearings, crane travelling wheels	N7	Cannot be displaced
Light and variable loads (P ≤ 0,05 C)	Conveyor rollers, rope sheaves, belt tensioner pulleys	M7	Cannot be displaced
Direction of load indeterminate			
Heavy shock loads	Electric traction motors	M7	Cannot be displaced
Normal to heavy loads, (P > 0,05 C) axial displacement of outer ring unnecessary	Electric motors, pumps, crankshaft bearings	K7	Cannot be displaced as a rule
Accurate or quiet running²⁾			
Ball bearings	Small electric motors	J6 ³⁾	Can be displaced
Taper roller bearings	When adjusted via the outer ring	JS5	–
	Axially located outer ring	K5	–
	Rotating outer ring load	M5	–

¹⁾ For ball bearings with D ≤ 100 mm, tolerance grade IT6 is often preferable and is recommended for bearings with thin-walled rings, e.g. in the 7, 8 or 9 Diameter Series. For these series, cylindricity tolerances IT4 are also recommended

²⁾ For high-precision bearings to tolerance class P5 or better, other recommendations apply (→ the SKF catalogue “High-precision bearings”)

³⁾ When easy displacement is required use H6 instead of J6

Table 5

Fits for cast iron and steel housings

Radial bearings – split or non-split housings

Conditions	Examples	Tolerance ¹⁾	Displacement of outer ring
Direction of load indeterminate			
Light to normal loads ($P \leq 0,1 C$) axial displacement of outer ring desirable	Medium-sized electrical machines, pumps, crankshaft bearings	J7	Can be displaced as a rule
Stationary outer ring load			
Loads of all kinds	General engineering, railway axleboxes	H7 ²⁾	Can be displaced
Light to normal loads ($P \leq 0,1 C$) with simple working conditions	General engineering	H8	Can be displaced
Heat conduction through shaft	Drying cylinders, large electrical machines with spherical roller bearings	G7 ³⁾	Can be displaced

¹⁾ For ball bearings with $D \leq 100$ mm, tolerance grade IT6 is often preferable and is recommended for bearings with thin-walled rings, e.g. in the 7, 8 or 9 Diameter Series. For these series, cylindricity tolerances IT4 are also recommended

²⁾ For large bearings ($D > 250$ mm) and temperature differences between outer ring and housing > 10 °C, G7 should be used instead of H7

³⁾ For large bearings ($D > 250$ mm) and temperature differences between outer ring and housing > 10 °C, F7 should be used instead of G7

Table 6

Fits for cast iron and steel housings

Thrust bearings

Conditions	Tolerance	Remarks
Axial loads only		
Thrust ball bearings	H8	For less accurate bearing arrangements there can be a radial clearance of up to $0,001 D$
Cylindrical roller thrust bearings	H7 (H9)	
Cylindrical roller and cage thrust assemblies	H10	
Spherical roller thrust bearings where separate bearings provide radial location	–	Housing washer must be fitted with adequate radial clearance so that no radial load whatsoever can act on the thrust bearings
Combined radial and axial loads on spherical roller thrust bearings		
Stationary load on housing washer	H7	See also “Design of associated components” in section “Spherical roller thrust bearings” on page 881
Rotating load on housing washer	M7	

Application of bearings

Tolerance tables

The values shown in **tables 7 and 8** for the shaft and housing tolerances enable the character of the fit to be established

- the upper and lower limits of Normal tolerances for the bearing bore and outside diameter deviations
- the upper and lower limits of the shaft and housing bore diameter deviations in accordance with ISO 286-2:1988
- the smallest and largest values of the theoretical interference (+) or clearance (–) in the fit
- the smallest and largest values of the probable interference (+) or clearance (–) in the fit.

The appropriate values for rolling bearing seatings on shafts are listed for the tolerances

e7, f5, f6, g5, g6

in **table 7a, pages 174 and 175**

h5, h6, h8, h9, j5

in **table 7b, pages 176 and 177**

j6, js5, js6, js7, k4

in **table 7c, pages 178 and 179**

k5, k6, m5, m6, n5

in **table 7d, pages 180 and 181**

n6, p6, p7, r6, r7

in **table 7e, pages 182 and 183**

The appropriate values for the rolling bearing housing seatings are listed for the tolerances

F7, G6, G7, H5, H6

in **table 8a, pages 184 and 185**

H7, H8, H9, H10, J6

in **table 8b, pages 186 and 187**

J7, JS5, JS6, JS7, K5

in **table 8c, pages 188 and 189**

K6, K7, M5, M6, M7

in **table 8d, pages 190 and 191**

N6, N7, P6, P7

in **table 8e, pages 192 and 193**

The Normal tolerances for the bore and outside diameter for which the limiting values have been calculated are valid for all metric rolling bearings with the exception of metric taper roller bearings when $d \leq 30$ mm and $D \leq 150$ mm and for thrust bearings when $D \leq 150$ mm. The diameter tolerances for these bearings deviate from

the Normal tolerances for the other rolling bearings (→ tolerance tables on **pages 125 to 132**).

The values for the probable interference or clearance cover 99 % of all the combinations of the theoretical interference or clearance.

When bearings of higher accuracy than Normal are used, the reduced bore and outside tolerances mean that the interference or clearance of the fits is reduced correspondingly. If, in such cases, a more accurate calculation of the limits is required it is advisable to contact the SKF application engineering service.

Fits for hollow shafts

If bearings are to be mounted with an interference fit on a hollow shaft it is generally necessary to use a heavier interference fit than would be used for a solid shaft in order to achieve the same surface pressure between the inner ring and shaft seating. The following diameter ratios are important when deciding on the fit to be used

$$c_i = \frac{d_i}{d} \text{ and } c_e = \frac{d}{d_e}$$

The fit is not appreciably affected until the diameter ratio of the hollow shaft $c_i \geq 0,5$. If the average outside diameter of the inner ring is not known, the diameter ratio c_e can be calculated with sufficient accuracy using the equation

$$c_e = \frac{d}{k(D - d) + d}$$

where

c_i = diameter ratio of the hollow shaft

c_e = diameter ratio of the inner ring

d = outside diameter of the hollow shaft, bore diameter of the bearing, mm

d_i = internal diameter of the hollow shaft, mm

d_e = average outside diameter of the inner ring, mm

D = outside bearing diameter, mm

k = a factor for the bearing type

for self-aligning ball bearings in the 22 and 23 series, $k = 0,25$

for cylindrical roller bearings, $k = 0,25$

for all other bearings, $k = 0,3$

To determine the requisite interference fit for a bearing to be mounted on a hollow shaft, use the mean probable interference between the shaft seating and bearing bore obtained for the tolerance recommendation for a solid shaft of the same diameter. If the plastic deformation (smoothing) of the mating surfaces produced during mounting is neglected, then the effective interference can be equated to the mean probable interference.

The interference Δ_H needed for a hollow steel shaft can then be determined in relation to the known interference Δ_V for the solid shaft from **diagram 1**. Δ_V equals the mean value of the smallest and largest values of the probable interference for the solid shaft. The tolerance for the hollow shaft is then selected so that the mean probable interference is as close as possible to the interference Δ_H obtained from **diagram 1**.

Example

A 6208 deep groove ball bearing with $d = 40$ mm and $D = 80$ mm is to be mounted on a hollow shaft having a diameter ratio $c_i = 0,8$. What is the requisite interference and what are the appropriate shaft limits?

If the bearing were to be mounted on a solid steel shaft and subjected to normal loads, a tolerance k5 would be recommended. From **table 7d, page 180**, a shaft diameter of 40 mm, the mean probable interference $\Delta_V = (22 + 5)/2 = 13,5 \mu\text{m}$. For $c_i = 0,8$ and

$$c_e = \frac{40}{0,3(80 - 40) + 40} = 0,77$$

so that from **diagram 1** the ratio $\Delta_H/\Delta_V = 1,7$. Thus the requisite interference for the hollow shaft $\Delta_H = 1,7 \times 13,5 = 23 \mu\text{m}$. Consequently, tolerance m6 is selected for the hollow shaft as this gives a mean probable interference of this order.

Diagram 1

Relation of interference Δ_H , needed for a hollow steel shaft, to the known interference Δ_V for a solid steel shaft

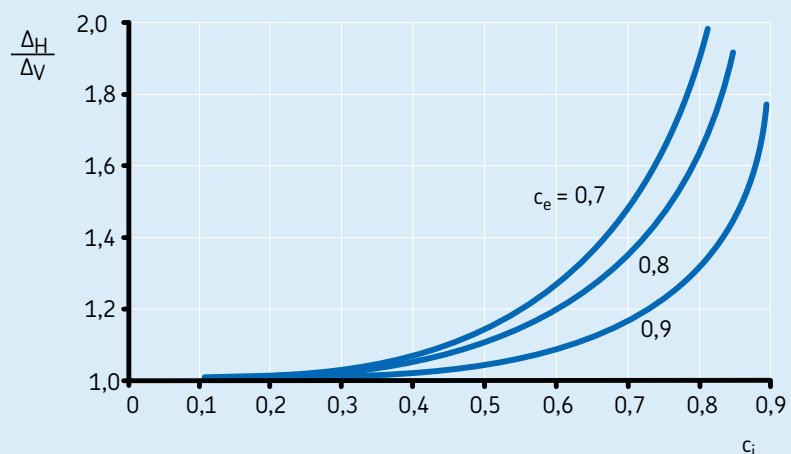
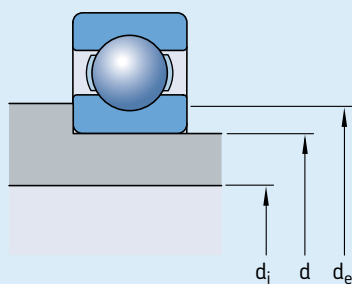

Application of bearings

Table 7a

Shaft tolerances and resultant fits													
Shaft Nominal diameter d		Bearing Bore diameter tolerance Δ_{dmp}		Deviations of shaft diameter, resultant fits									
				Tolerances									
				e7	f5	f6	g5	g6					
				Deviations (shaft diameter)									
				Theoretical interference (+)/clearance (-)									
				Probable interference (+)/clearance (-)									
over	incl.	low	high										
mm		μm		μm									
1	3	-8	0	-14	-24	-6	-10	-6	-12	-2	-6	-2	-8
				-6	-24	+2	-10	+2	-12	+6	-6	+6	-8
				-8	-22	+1	-9	0	-10	+5	-5	+4	-6
3	6	-8	0	-20	-32	-10	-15	-10	-18	-4	-9	-4	-12
				-12	-32	-2	-15	-2	-18	+4	-9	+4	-12
				-14	-30	-3	-14	-4	-16	+3	-8	+2	-10
6	10	-8	0	-25	-40	-13	-19	-13	-22	-5	-11	-5	-14
				-17	-40	-5	-19	-5	-22	+3	-11	+3	-14
				-20	-37	-7	-17	-7	-20	+1	-9	+1	-12
10	18	-8	0	-32	-50	-16	-24	-16	-27	-6	-14	-6	-17
				-24	-50	-8	-24	-8	-27	+2	-14	+2	-17
				-27	-47	-10	-22	-10	-25	0	-12	0	-15
18	30	-10	0	-40	-61	-20	-29	-20	-33	-7	-16	-7	-20
				-30	-61	-10	-29	-10	-33	+3	-16	+3	-20
				-33	-58	-12	-27	-13	-30	+1	-14	0	-17
30	50	-12	0	-50	-75	-25	-36	-25	-41	-9	-20	-9	-25
				-38	-75	-13	-36	-13	-41	+3	-20	+3	-25
				-42	-71	-16	-33	-17	-37	0	-17	-1	-21
50	80	-15	0	-60	-90	-30	-43	-30	-49	-10	-23	-10	-29
				-45	-90	-15	-43	-15	-49	+5	-23	+5	-29
				-50	-85	-19	-39	-19	-45	+1	-19	+1	-25
80	120	-20	0	-72	-107	-36	-51	-36	-58	-12	-27	-12	-34
				-52	-107	-16	-51	-16	-58	+8	-27	+8	-34
				-59	-100	-21	-46	-22	-52	+3	-22	+2	-28
120	180	-25	0	-85	-125	-43	-61	-43	-68	-14	-32	-14	-39
				-60	-125	-18	-61	-18	-68	+11	-32	+11	-39
				-68	-117	-24	-55	-25	-61	+5	-26	+4	-32
180	250	-30	0	-100	-146	-50	-70	-50	-79	-15	-35	-15	-44
				-70	-146	-20	-70	-20	-79	+15	-35	+15	-44
				-80	-136	-26	-64	-28	-71	+9	-29	+7	-36
250	315	-35	0	-110	-162	-56	-79	-56	-88	-17	-40	-17	-49
				-75	-162	-21	-79	-21	-88	+18	-40	+18	-49
				-87	-150	-29	-71	-30	-79	+10	-32	+9	-40
315	400	-40	0	-125	-182	-62	-87	-62	-98	-18	-43	-18	-54
				-85	-182	-22	-87	-22	-98	+22	-43	+22	-54
				-98	-169	-30	-79	-33	-87	+14	-35	+11	-43
400	500	-45	0	-135	-198	-68	-95	-68	-108	-20	-47	-20	-60
				-90	-198	-23	-95	-23	-108	+25	-47	+25	-60
				-105	-183	-32	-86	-35	-96	+16	-38	+13	-48

Table 7a

Shaft tolerances and resultant fits

Shaft Nominal diameter d		Bearing Bore diameter tolerance Δ_{dmp}		Deviations of shaft diameter, resultant fits Tolerances									
				e7	f5		f6		g5		g6		
over	incl.	low	high	Deviations (shaft diameter)									
				Theoretical interference (+)/clearance (-)									
				Probable interference (+)/clearance (-)									
mm		μm		μm									
500	630	-50	0	-145	-215	-76	-104	-76	-120	-22	-50	-22	-66
				-95	-215	-26	-104	-26	-120	+28	-50	+28	-66
				-111	-199	-36	-94	-39	-107	+18	-40	+15	-53
630	800	-75	0	-160	-240	-80	-112	-80	-130	-24	-56	-24	-74
				-85	-240	-5	-112	-5	-130	+51	-56	+51	-74
				-107	-218	-17	-100	-22	-113	+39	-44	+34	-57
800	1 000	-100	0	-170	-260	-86	-122	-86	-142	-26	-62	-26	-82
				-70	-260	+14	-122	+14	-142	+74	-62	+74	-82
				-97	-233	0	-108	-6	-122	+60	-48	+54	-62
1 000	1 250	-125	0	-195	-300	-98	-140	-98	-164	-28	-70	-28	-94
				-70	-300	+27	-140	+27	-164	+97	-70	+97	-94
				-103	-267	+10	-123	+3	-140	+80	-53	+73	-70
1 250	1 600	-160	0	-220	-345	-110	-160	-110	-188	-30	-80	-30	-108
				-60	-345	+50	-160	+50	-188	+130	-80	+130	-108
				-100	-305	+29	-139	+20	-158	+109	-59	+100	-78
1 600	2 000	-200	0	-240	-390	-120	-180	-120	-212	-32	-92	-32	-124
				-40	-390	+80	-180	+80	-212	+168	-92	+168	-124
				-90	-340	+55	-155	+45	-177	+143	-67	+133	-89

Table 7b

Shaft tolerances and resultant fits

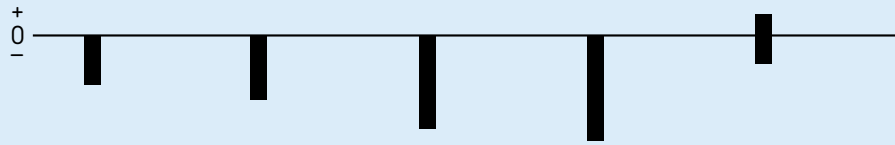

Shaft Nominal diameter d		Bearing Bore diameter tolerance Δ_{dmp}		Deviations of shaft diameter, resultant fits Tolerances									
				h5		h6		h8		h9		j5	
over	incl.	low	high	Deviations (shaft diameter)									
				Theoretical interference (+)/clearance (-)									
				Probable interference (+)/clearance (-)									
mm		μm		μm									
1	3	-8	0	0	-4	0	-6	0	-14	0	-25	+2	-2
				+8	-4	+8	-6	+8	-14	+8	-25	+10	-2
				+7	-3	+6	-4	+6	-12	+5	-22	+9	-1
3	6	-8	0	0	-5	0	-8	0	-18	0	-30	+3	-2
				+8	-5	+8	-8	+8	-18	+8	-30	+11	-2
				+7	-4	+6	-6	+5	-15	+5	-27	+10	-1
6	10	-8	0	0	-6	0	-9	0	-22	0	-36	+4	-2
				+8	-6	+8	-9	+8	-22	+8	-36	+12	-2
				+6	-4	+6	-7	+5	-19	+5	-33	+10	0
10	18	-8	0	0	-8	0	-11	0	-27	0	-43	+5	-3
				+8	-8	+8	-11	+8	-27	+8	-43	+13	-3
				+6	-6	+6	-9	+5	-24	+5	-40	+11	-1
18	30	-10	0	0	-9	0	-13	0	-33	0	-52	+5	-4
				+10	-9	+10	-13	+10	-33	+10	-52	+15	-4
				+8	-7	+7	-10	+6	-29	+6	-48	+13	-2
30	50	-12	0	0	-11	0	-16	0	-39	0	-62	+6	-5
				+12	-11	+12	-16	+12	-39	+12	-62	+18	-5
				+9	-8	+8	-12	+7	-34	+7	-57	+15	-2
50	80	-15	0	0	-13	0	-19	0	-46	0	-74	+6	-7
				+15	-13	+15	-19	+15	-46	+15	-74	+21	-7
				+11	-9	+11	-15	+9	-40	+9	-68	+17	-3
80	120	-20	0	0	-15	0	-22	0	-54	0	-87	+6	-9
				+20	-15	+20	-22	+20	-54	+20	-87	+26	-9
				+15	-10	+14	-16	+12	-46	+12	-79	+21	-4
120	180	-25	0	0	-18	0	-25	0	-63	0	-100	+7	-11
				+25	-18	+25	-25	+25	-63	+25	-100	+32	-11
				+19	-12	+18	-18	+15	-53	+15	-90	+26	-5
180	250	-30	0	0	-20	0	-29	0	-72	0	-115	+7	-13
				+30	-20	+30	-29	+30	-72	+30	-115	+37	-13
				+24	-14	+22	-21	+18	-60	+17	-102	+31	-7
250	315	-35	0	0	-23	0	-32	0	-81	0	-130	+7	-16
				+35	-23	+35	-32	+35	-81	+35	-130	+42	-16
				+27	-15	+26	-23	+22	-68	+20	-115	+34	-8
315	400	-40	0	0	-25	0	-36	0	-89	0	-140	+7	-18
				+40	-25	+40	-36	+40	-89	+40	-140	+47	-18
				+32	-17	+29	-25	+25	-74	+23	-123	+39	-10
400	500	-45	0	0	-27	0	-40	0	-97	0	-155	+7	-20
				+45	-27	+45	-40	+45	-97	+45	-155	+52	-20
				+36	-18	+33	-28	+28	-80	+26	-136	+43	-11

Table 7b

Shaft tolerances and resultant fits

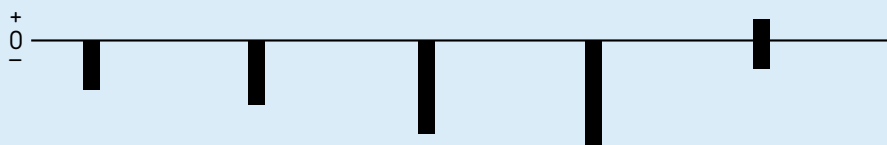

Shaft Nominal diameter d		Bearing Bore diameter tolerance Δ_{dmp}		Deviations of shaft diameter, resultant fits Tolerances									
				h5	h6		h8		h9		j5		
over	incl.	low	high	Deviations (shaft diameter)									
				Theoretical interference (+)/clearance (-)									
				Probable interference (+)/clearance (-)									
mm		μm		μm									
500	630	-50	0	0	-28	0	-44	0	-110	0	-175	-	-
				+50	-28	+50	-44	+50	-110	+50	-175	-	-
				+40	-18	+37	-31	+31	-91	+29	-154	-	-
630	800	-75	0	0	-32	0	-50	0	-125	0	-200	-	-
				+75	-32	+75	-50	+75	-125	+75	-200	-	-
				+63	-20	+58	-33	+48	-98	+45	-170	-	-
800	1 000	-100	0	0	-36	0	-56	0	-140	0	-230	-	-
				+100	-36	+100	-56	+100	-140	+100	-230	-	-
				+86	-22	+80	-36	+67	-107	+61	-191	-	-
1 000	1 250	-125	0	0	-42	0	-66	0	-165	0	-260	-	-
				+125	-42	+125	-66	+125	-165	+125	-260	-	-
				+108	-25	+101	-42	+84	-124	+77	-212	-	-
1 250	1 600	-160	0	0	-50	0	-78	0	-195	0	-310	-	-
				+160	-50	+160	-78	+160	-195	+160	-310	-	-
				+139	-29	+130	-48	+109	-144	+100	-250	-	-
1 600	2 000	-200	0	0	-60	0	-92	0	-230	0	-370	-	-
				+200	-60	+200	-92	+200	-230	+200	-370	-	-
				+175	-35	+165	-57	+138	-168	+126	-296	-	-

Table 7c

Shaft tolerances and resultant fits

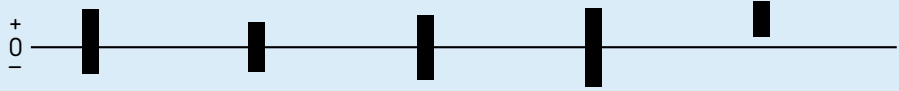

Shaft Nominal diameter d		Bearing Bore diameter tolerance Δ_{dmp}		Deviations of shaft diameter, resultant fits									
				Tolerances									
				j6		js5		js6		js7		k4	
				Deviations (shaft diameter)									
				Theoretical interference (+)/clearance (-)									
				Probable interference (+)/clearance (-)									
over	incl.	low	high										
mm		μm		μm									
1	3	-8	0	+4	-2	+2	-2	+3	-3	+5	-5	+3	0
				+12	-2	+10	-2	+11	-3	+13	-5	+11	0
				+10	0	+9	-1	+9	-1	+11	-3	+10	+1
3	6	-8	0	+6	-2	+2,5	-2,5	+4	-4	+6	-6	+5	+1
				+14	-2	+10,5	-2,5	+12	-4	+14	-6	+13	+1
				+12	0	+9	-1	+10	-2	+12	-4	+12	+2
6	10	-8	0	+7	-2	+3	-3	+4,5	-4,5	+7,5	-7,5	+5	+1
				+15	-2	+11	-3	+12,5	-4,5	+15,5	-7,5	+13	+1
				+13	0	+9	-1	+11	-3	+13	-5	+12	+2
10	18	-8	0	+8	-3	+4	-4	+5,5	-5,5	+9	-9	+6	+1
				+16	-3	+12	-4	+13,5	-5,5	+17	-9	+14	+1
				+14	-1	+10	-2	+11	-3	+14	-6	+13	+2
18	30	-10	0	+9	-4	+4,5	-4,5	+6,5	-6,5	+10,5	-10,5	+8	+2
				+19	-4	+14,5	-4,5	+16,5	-6,5	+20,5	-10,5	+18	+2
				+16	-1	+12	-2	+14	-4	+17	-7	+16	+4
30	50	-12	0	+11	-5	+5,5	-5,5	+8	-8	+12,5	-12,5	+9	+2
				+23	-5	+17,5	-5,5	+20	-8	+24,5	-12,5	+21	+2
				+19	-1	+15	-3	+16	-4	+20	-8	+19	+4
50	80	-15	0	+12	-7	+6,5	-6,5	+9,5	-9,5	+15	-15	+10	+2
				+27	-7	+21,5	-6,5	+24,5	-9,5	+30	-15	+25	+2
				+23	-3	+18	-3	+20	-5	+25	-10	+22	+5
80	120	-20	0	+13	-9	+7,5	-7,5	+11	-11	+17,5	-17,5	+13	+3
				+33	-9	+27,5	-7,5	+31	-11	+37,5	-17,5	+33	+3
				+27	-3	+23	-3	+25	-5	+31	-11	+30	+6
120	180	-25	0	+14	-11	+9	-9	+12,5	-12,5	+20	-20	+15	+3
				+39	-11	+34	-9	+37,5	-12,5	+45	-20	+40	+3
				+32	-4	+28	-3	+31	-6	+37	-12	+36	+7
180	250	-30	0	+16	-13	+10	-10	+14,5	-14,5	+23	-23	+18	+4
				+46	-13	+40	-10	+44,5	-14,5	+53	-23	+48	+4
				+38	-5	+34	-4	+36	-6	+43	-13	+43	+9
250	315	-35	0	+16	-16	+11,5	-11,5	+16	-16	+26	-26	+20	+4
				+51	-16	+46,5	-11,5	+51	-16	+61	-26	+55	+4
				+42	-7	+39	-4	+42	-7	+49	-14	+49	+10
315	400	-40	0	+18	-18	+12,5	-12,5	+18	-18	+28,5	-28,5	+22	+4
				+58	-18	+52,5	-12,5	+58	-18	+68,5	-28,5	+62	+4
				+47	-7	+44	-4	+47	-7	+55	-15	+55	+11
400	500	-45	0	+20	-20	+13,5	-13,5	+20	-20	+31,5	-31,5	+25	+5
				+65	-20	+58,5	-13,5	+65	-20	+76,5	-31,5	+70	+5
				+53	-8	+49	-4	+53	-8	+62	-17	+63	-12

Table 7c

Shaft tolerances and resultant fits

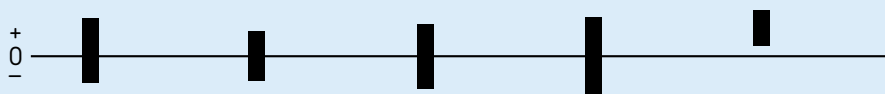

Shaft Nominal diameter d		Bearing Bore diameter tolerance Δ_{dmp}		Deviations of shaft diameter, resultant fits Tolerances									
				j6	js5		js6		js7		k4		
				Deviations (shaft diameter)									
				Theoretical interference (+)/clearance (-)									
				Probable interference (+)/clearance (-)									
over	incl.	low	high										
mm		μm		μm									
500	630	-50	0	+22	-22	+14	-14	+22	-22	+35	-35	-	-
				+72	-22	+64	-14	+72	-22	+85	-35	-	-
				+59	-9	+54	-4	+59	-9	+69	-19	-	-
630	800	-75	0	+25	-25	+16	-16	+25	-25	+40	-40	-	-
				+100	-25	+91	-16	+100	-25	+115	-40	-	-
				+83	-8	+79	-4	+83	-8	+93	-18	-	-
800	1 000	-100	0	+28	-28	+18	-18	+28	-28	+45	-45	-	-
				+128	-28	+118	-18	+128	-28	+145	-45	-	-
				+108	-8	+104	-4	+108	-8	+118	-18	-	-
1 000	1 250	-125	0	+33	-33	+21	-21	+33	-33	+52	-52	-	-
				+158	-33	+146	-21	+158	-33	+177	-52	-	-
				+134	-9	+129	-4	+134	-9	+145	-20	-	-
1 250	1 600	-160	0	+39	-39	+25	-25	+39	-39	+62	-62	-	-
				+199	-39	+185	-25	+199	-39	+222	-62	-	-
				+169	-9	+164	-4	+169	-9	+182	-22	-	-
1 600	2 000	-200	0	+46	-46	+30	-30	+46	-46	+75	-75	-	-
				+246	-46	+230	-30	+246	-46	+275	-75	-	-
				+211	-11	+205	-5	+211	-11	+225	-25	-	-

Table 7d

Shaft tolerances and resultant fits



Shaft Nominal diameter d		Bearing Bore diameter tolerance Δ_{dmp}		Deviations of shaft diameter, resultant fits									
				k5		k6		m5		m6		n5	
over	incl.	low	high	Deviations (shaft diameter)									
				Theoretical interference (+)/clearance (-)									
				Probable interference (+)/clearance (-)									
mm		μm		μm									
1	3	-8	0	+4	0	+6	0	+6	+2	+8	+2	+8	+4
				+12	0	+14	0	+14	+2	+16	+2	+16	+4
				+11	+1	+12	+2	+13	+3	+14	+4	+15	+5
3	6	-8	0	+6	+1	+9	+1	+9	+4	+12	+4	+13	+8
				+14	+1	+17	+1	+17	+4	+20	+4	+21	+8
				+13	+2	+15	+3	+16	+5	+18	+6	+20	+9
6	10	-8	0	+7	+1	+10	+1	+12	+6	+15	+6	+16	+10
				+15	+1	+18	+1	+20	+6	+23	+6	+24	+10
				+13	+3	+16	+3	+18	+8	+21	+8	+22	+12
10	18	-8	0	+9	+1	+12	+1	+15	+7	+18	+7	+20	+12
				+17	+1	+20	+1	+23	+7	+26	+7	+28	+12
				+15	+3	+18	+3	+21	+9	+24	+9	+26	+14
18	30	-10	0	+11	+2	+15	+2	+17	+8	+21	+8	+24	+15
				+21	+2	+25	+2	+27	+8	+31	+8	+34	+15
				+19	+4	+22	+5	+25	+10	+28	+11	+32	+17
30	50	-12	0	+13	+2	+18	+2	+20	+9	+25	+9	+28	+17
				+25	+2	+30	+2	+32	+9	+37	+9	+40	+17
				+22	+5	+26	+6	+29	+12	+33	+13	+37	+20
50	80	-15	0	+15	+2	+21	+2	+24	+11	+30	+11	+33	+20
				+30	+2	+36	+2	+39	+11	+45	+11	+48	+20
				+26	+6	+32	+6	+35	+15	+41	+15	+44	+24
80	120	-20	0	+18	+3	+25	+3	+28	+13	+35	+13	+38	+23
				+38	+3	+45	+3	+48	+13	+55	+13	+58	+23
				+33	+8	+39	+9	+43	+18	+49	+19	+53	+28
120	180	-25	0	+21	+3	+28	+3	+33	+15	+40	+15	+45	+27
				+46	+3	+53	+3	+58	+15	+65	+15	+70	+27
				+40	+9	+46	+10	+52	+21	+58	+22	+64	+33
180	250	-30	0	+24	+4	+33	+4	+37	+17	+46	+17	+51	+31
				+54	+4	+63	+4	+67	+17	+76	+17	+81	+31
				+48	+10	+55	+12	+61	+23	+68	+25	+75	+37
250	315	-35	0	+27	+4	+36	+4	+43	+20	+52	+20	+57	+34
				+62	+4	+71	+4	+78	+20	+87	+20	+92	+34
				+54	+12	+62	+13	+70	+28	+78	+29	+84	+42
315	400	-40	0	+29	+4	+40	+4	+46	+21	+57	+21	+62	+37
				+69	+4	+80	+4	+86	+21	+97	+21	+102	+37
				+61	+12	+69	+15	+78	+29	+86	+32	+94	+45
400	500	-45	0	+32	+5	+45	+5	+50	+23	+63	+23	+67	+40
				+77	+5	+90	+5	+95	+23	+108	+23	+112	+40
				+68	+14	+78	+17	+86	+32	+96	+35	+103	+49

Table 7d

Shaft tolerances and resultant fits

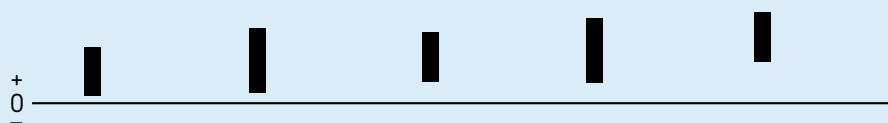

Shaft Nominal diameter d		Bearing Bore diameter tolerance Δ_{dmp}		Deviations of shaft diameter, resultant fits										
				Tolerances										
				k5	k6		m5		m6		n5			
				Deviations (shaft diameter)										
				Theoretical interference (+)/clearance (-)										
				Probable interference (+)/clearance (-)										
over	incl.	low	high											
mm		μm		μm										
500	630	-50	0	+29	0	+44	0	+55	+26	+70	+26	+73	+44	
				+78	0	+94	0	+104	+26	+120	+26	+122	+44	
				+68	+10	+81	+13	+94	+36	+107	+39	+112	+54	
630	800	-75	0	+32	0	+50	0	+62	+30	+80	+30	+82	+50	
				+107	0	+125	0	+137	+30	+155	+30	+157	+50	
				+95	+12	+108	+17	+125	+42	+138	+47	+145	+62	
800	1 000	-100	0	+36	0	+56	0	+70	+34	+90	+34	+92	+56	
				+136	0	+156	0	+170	+34	+190	+34	+192	+56	
				+122	+14	+136	+20	+156	+48	+170	+54	+178	+70	
1 000	1 250	-125	0	+42	0	+66	0	+82	+40	+106	+40	+108	+66	
				+167	0	+191	0	+207	+40	+231	+40	+233	+66	
				+150	+17	+167	+24	+190	+57	+207	+64	+216	+83	
1 250	1 600	-160	0	+50	0	+78	0	+98	+48	+126	+48	+128	+78	
				+210	0	+238	0	+258	+48	+286	+48	+288	+78	
				+189	+21	+208	+30	+237	+69	+256	+78	+267	+99	
1 600	2 000	-200	0	+60	0	+92	0	+118	+58	+150	+58	+152	+92	
				+260	0	+292	0	+318	+58	+350	+58	+352	+92	
				+235	+25	+257	+35	+293	+83	+315	+93	+327	+117	

Table 7e

Shaft tolerances and resultant fits

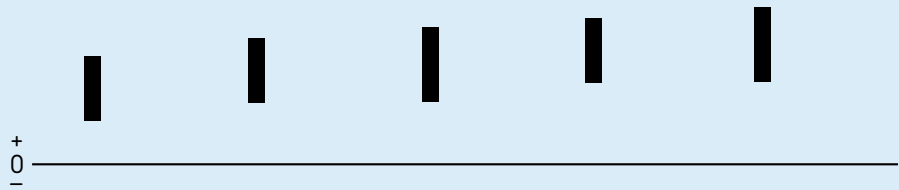

Shaft Nominal diameter d		Bearing Bore diameter tolerance Δ_{dmp}		Deviations of shaft diameter, resultant fits										
				Tolerances										
				n6	p6		p7		r6		r7			
				Deviations (shaft diameter)										
				Theoretical interference (+)/clearance (-)										
				Probable interference (+)/clearance (-)										
over	incl.	low	high											
mm		μm		μm										
80	100	-20	0	+45	+23	+59	+37	+72	+37	+73	+51	+86	+51	
				+65	+23	+79	+37	+92	+37	+93	+51	+106	+51	
				+59	+29	+73	+43	+85	+44	+87	+57	+99	+58	
100	120	-20	0	+45	+23	+59	+37	+72	+37	+76	+54	+89	+54	
				+65	+23	+79	+37	+92	+37	+96	+54	+109	+54	
				+59	+29	+73	+43	+85	+44	+90	+60	+102	+61	
120	140	-25	0	+52	+27	+68	+43	+83	+43	+88	+63	+103	+63	
				+77	+27	+93	+43	+108	+43	+113	+63	+128	+63	
				+70	+34	+86	+50	+100	+51	+106	+70	+120	+71	
140	160	-25	0	+52	+27	+68	+43	+83	+43	+90	+65	+105	+65	
				+77	+27	+93	+43	+108	+43	+115	+65	+130	+65	
				+70	+34	+86	+50	+100	+51	+108	+72	+122	+73	
160	180	-25	0	+52	+27	+68	+43	+83	+43	+93	+68	+108	+68	
				+77	+27	+93	+43	+108	+43	+118	+68	+133	+68	
				+70	+34	+86	+50	+100	+51	+111	+75	+125	+76	
180	200	-30	0	+60	+31	+79	+50	+96	+50	+106	+77	+123	+77	
				+90	+31	+109	+50	+126	+50	+136	+77	+153	+77	
				+82	+39	+101	+58	+116	+60	+128	+85	+143	+87	
200	225	-30	0	+60	+31	+79	+50	+96	+50	+109	+80	+126	+80	
				+90	+31	+109	+50	+126	+50	+139	+80	+156	+80	
				+82	+39	+101	+58	+116	+60	+131	+88	+146	+90	
225	250	-30	0	+60	+31	+79	+50	+96	+50	+113	+84	+130	+84	
				+90	+31	+109	+50	+126	+50	+143	+84	+160	+84	
				+82	+39	+101	+58	+116	+60	+135	+92	+150	+94	
250	280	-35	0	+66	+34	+88	+56	+108	+56	+126	+94	+146	+94	
				+101	+34	+123	+56	+143	+56	+161	+94	+181	+94	
				+92	+43	+114	+65	+131	+68	+152	+103	+169	+106	
280	315	-35	0	+66	+34	+88	+56	+108	+56	+130	+98	+150	+98	
				+101	+34	+123	+56	+143	+56	+165	+98	+185	+98	
				+92	+43	+114	+65	+131	+68	+156	+107	+173	+110	
315	355	-40	0	+73	+37	+98	+62	+119	+62	+144	+108	+165	+108	
				+113	+37	+138	+62	+159	+62	+184	+108	+205	+108	
				+102	+48	+127	+73	+146	+75	+173	+119	+192	+121	
355	400	-40	0	+73	+37	+98	+62	+119	+62	+150	+114	+171	+114	
				+113	+37	+138	+62	+159	+62	+190	+114	+211	+114	
				+102	+48	+127	+73	+146	+75	+179	+125	+198	+127	
400	450	-45	0	+80	+40	+108	+68	+131	+68	+166	+126	+189	+126	
				+125	+40	+153	+68	+176	+68	+211	+126	+234	+126	
				+113	+52	+141	+80	+161	+83	+199	+138	+219	+141	

Table 7e

Shaft tolerances and resultant fits

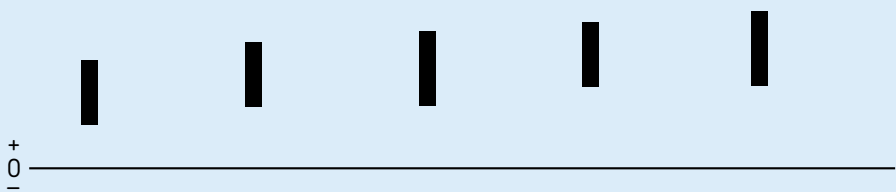

Shaft Nominal diameter d		Bearing Bore diameter tolerance Δ_{dmp}		Deviations of shaft diameter, resultant fits									
				Tolerances									
				n6	p6		p7	r6		r7			
over	incl.	low	high	Deviations (shaft diameter)									
				Theoretical interference (+)/clearance (-)									
				Probable interference (+)/clearance (-)									
mm		μm		μm									
450	500	-45	0	+80	+40	+108	+68	+131	+68	+172	+132	+195	+132
				+125	+40	+153	+68	+176	+68	+217	+132	+240	+132
				+113	+52	+141	+80	+161	+83	+205	+144	+225	+147
500	560	-50	0	+88	+44	+122	+78	+148	+78	+194	+150	+220	+150
				+138	+44	+172	+78	+198	+78	+244	+150	+270	+150
				+125	+57	+159	+91	+182	+94	+231	+163	+254	+166
560	630	-50	0	+88	+44	+122	+78	+148	+78	+199	+155	+225	+155
				+138	+44	+172	+78	+198	+78	+249	+155	+275	+155
				+125	+57	+159	+91	+182	+94	+236	+168	+259	+171
630	710	-75	0	+100	+50	+138	+88	+168	+88	+225	+175	+255	+175
				+175	+50	+213	+88	+243	+88	+300	+175	+330	+175
				+158	+67	+196	+105	+221	+110	+283	+192	+308	+197
710	800	-75	0	+100	+50	+138	+88	+168	+88	+235	+185	+265	+185
				+175	+50	+213	+88	+243	+88	+310	+185	+340	+185
				+158	+67	+196	+105	+221	+110	+293	+202	+318	+207
800	900	-100	0	+112	+56	+156	+100	+190	+100	+266	+210	+300	+210
				+212	+56	+256	+100	+290	+100	+366	+210	+400	+210
				+192	+76	+236	+120	+263	+127	+346	+230	+373	+237
900	1 000	-100	0	+112	+56	+156	+100	+190	+100	+276	+220	+310	+220
				+212	+56	+256	+100	+290	+100	+376	+220	+410	+220
				+192	+76	+236	+120	+263	+127	+356	+240	+383	+247
1 000	1 120	-125	0	+132	+66	+186	+120	+225	+120	+316	+250	+355	+250
				+257	+66	+311	+120	+350	+120	+441	+250	+480	+250
				+233	+90	+287	+144	+317	+153	+417	+274	+447	+283
1 120	1 250	-125	0	+132	+66	+186	+120	+225	+120	+326	+260	+365	+260
				+257	+66	+311	+120	+350	+120	+451	+260	+490	+260
				+233	+90	+287	+144	+317	+153	+427	+284	+457	+293
1 250	1 400	-160	0	+156	+78	+218	+140	+265	+140	+378	+300	+425	+300
				+316	+78	+378	+140	+425	+140	+538	+300	+585	+300
				+286	+108	+348	+170	+385	+180	+508	+330	+545	+340
1 400	1 600	-160	0	+156	+78	+218	+140	+265	+140	+408	+330	+455	+330
				+316	+78	+378	+140	+425	+140	+568	+330	+615	+330
				+286	+108	+348	+170	+385	+180	+538	+360	+575	+370
1 600	1 800	-200	0	+184	+92	+262	+170	+320	+170	+462	+370	+520	+370
				+384	+92	+462	+170	+520	+170	+662	+370	+720	+370
				+349	+127	+427	+205	+470	+220	+627	+405	+670	+420
1 800	2 000	-200	0	+184	+92	+262	+170	+320	+170	+492	+400	+550	+400
				+384	+92	+462	+170	+520	+170	+692	+400	+750	+400
				+349	+127	+427	+205	+470	+220	+657	+435	+700	+450

Application of bearings

Table 8a

Housing tolerances and resultant fits

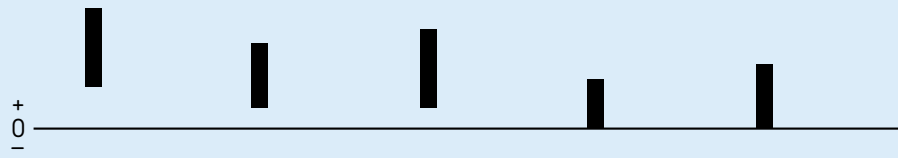

Housing Nominal bore diameter D		Bearing Outside diameter tolerance Δ_{Dmp}		Deviations of housing bore diameter, resultant fits Tolerances									
				F7		G6		G7		H5		H6	
over	incl.	high	low	Deviations (housing bore diameter)									
				Theoretical interference (+)/clearance (-)									
				Probable interference (+)/clearance (-)									
mm		μm		μm									
6	10	0	-8	+13	+28	+5	+14	+5	+20	0	+6	0	+9
				-13	-36	-5	-22	-5	-28	0	-14	0	-17
				-16	-33	-7	-20	-8	-25	-2	-12	-2	-15
10	18	0	-8	+16	+34	+6	+17	+6	+24	0	+8	0	+11
				-16	-42	-6	-25	-6	-32	0	-16	0	-19
				-19	-39	-8	-23	-9	-29	-2	-14	-2	-17
18	30	0	-9	+20	+41	+7	+20	+7	+28	0	+9	+0	+13
				-20	-50	-7	-29	-7	-37	0	-18	0	-22
				-23	-47	-10	-26	-10	-34	-2	-16	-3	-19
30	50	0	-11	+25	+50	+9	+25	+9	+34	0	+11	0	+16
				-25	-61	-9	-36	-9	-45	0	-22	0	-27
				-29	-57	-12	-33	-13	-41	-3	-19	-3	-24
50	80	0	-13	+30	+60	+10	+29	+10	+40	0	+13	0	+19
				-30	-73	-10	-42	-10	-53	0	-26	0	-32
				-35	-68	-14	-38	-15	-48	-3	-23	-4	-28
80	120	0	-15	+36	+71	+12	+34	+12	+47	0	+15	0	+22
				-36	-86	-12	-49	-12	-62	0	-30	0	-37
				-41	-81	-17	-44	-17	-57	-4	-26	-5	-32
120	150	0	-18	+43	+83	+14	+39	+14	+54	0	+18	0	+25
				-43	-101	-14	-57	-14	-72	0	-36	0	-43
				-50	-94	-20	-51	-21	-65	-5	-31	-6	-37
150	180	0	-25	+43	+83	+14	+39	+14	+54	0	+18	0	+25
				-43	-108	-14	-64	-14	-79	0	-43	0	-50
				-51	-100	-21	-57	-22	-71	-6	-37	-7	-43
180	250	0	-30	+50	+96	+15	+44	+15	+61	0	+20	0	+29
				-50	-126	-15	-74	-15	-91	0	-50	0	-59
				-60	-116	-23	-66	-25	-81	-6	-44	-8	-51
250	315	0	-35	+56	+108	+17	+49	+17	+69	0	+23	0	+32
				-56	-143	-17	-84	-17	-104	0	-58	0	-67
				-68	-131	-26	-75	-29	-92	-8	-50	-9	-58
315	400	0	-40	+62	+119	+18	+54	+18	+75	0	+25	0	+36
				-62	-159	-18	-94	-18	-115	0	-65	0	-76
				-75	-146	-29	-83	-31	-102	-8	-57	-11	-65
400	500	0	-45	+68	+131	+20	+60	+20	+83	0	+27	0	+40
				-68	-176	-20	-105	-20	-128	0	-72	0	-85
				-83	-161	-32	-93	-35	-113	-9	-63	-12	-73
500	630	0	-50	+76	+146	+22	+66	+22	+92	0	+28	0	+44
				-76	-196	-22	-116	-22	-142	0	-78	0	-94
				-92	-180	-35	-103	-38	-126	-10	-68	-13	-81

Table 8a

Housing tolerances and resultant fits

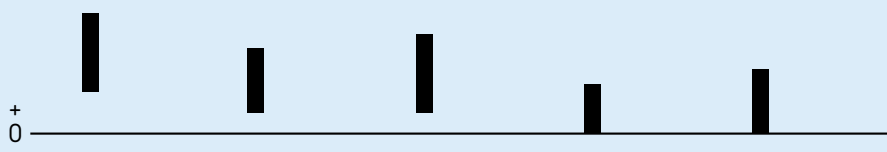

Housing Nominal bore diameter D		Bearing Outside diameter tolerance Δ_{Dmp}		Deviations of housing bore diameter, resultant fits Tolerances									
				F7		G6		G7		H5		H6	
over	incl.	high	low	Deviations (housing bore diameter)									
				Theoretical interference (+)/clearance (-)									
				Probable interference (+)/clearance (-)									
mm		μm		μm									
630	800	0	-75	+80	+160	+24	+74	+24	+104	0	+32	0	+50
				-80	-235	-24	-149	-24	-179	0	-107	0	-125
				-102	-213	-41	-132	-46	-157	-12	-95	-17	-108
800	1 000	0	-100	+86	+176	+26	+82	+26	+116	0	+36	0	+56
				-86	-276	-26	-182	-26	-216	0	-136	0	-156
				-113	-249	-46	-162	-53	-189	-14	-122	-20	-136
1 000	1 250	0	-125	+98	+203	+28	+94	+28	+133	0	+42	0	+66
				-98	-328	-28	-219	-28	-258	0	-167	0	-191
				-131	-295	-52	-195	-61	-225	-17	-150	-24	-167
1 250	1 600	0	-160	+110	+235	+30	+108	+30	+155	0	+50	0	+78
				-110	-395	-30	-268	-30	-315	0	-210	0	-238
				-150	-355	-60	-238	-70	-275	-21	-189	-30	-208
1 600	2 000	0	-200	+120	+270	+32	+124	+32	+182	0	+60	0	+92
				-120	-470	-32	-324	-32	-382	0	-260	0	-292
				-170	-420	-67	-289	-82	-332	-25	-235	-35	-257
2 000	2 500	0	-250	+130	+305	+34	+144	+34	+209	0	+70	0	+110
				-130	-555	-34	-394	-34	-459	0	-320	0	-360
				-189	-496	-77	-351	-93	-400	-30	-290	-43	-317

Table 8b

Housing tolerances and resultant fits

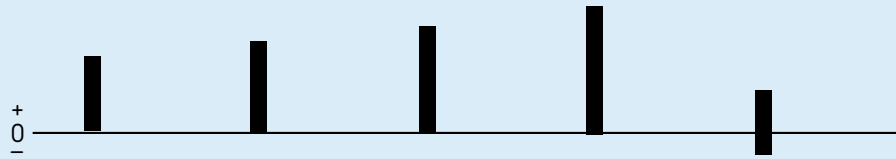

Housing Nominal bore diameter D		Bearing Outside diameter tolerance Δ_{Dmp}		Deviations of housing bore diameter, resultant fits									
				Tolerances									
				H7 H8 H9 H10 J6									
				Deviations (housing bore diameter)									
				Theoretical interference (+)/clearance (-)									
				Probable interference (+)/clearance (-)									
over	incl.	high	low										
mm		μm		μm									
6	10	0	-8	0	+15	0	+22	0	+36	0	+58	-4	+5
				0	-23	0	-30	0	-44	0	-66	+4	-13
				-3	-20	-3	-27	-3	-41	-3	-63	+2	-11
10	18	0	-8	0	+18	0	+27	0	+43	0	+70	-5	+6
				0	-26	0	-35	0	-51	0	-78	+5	-14
				-3	-23	-3	-32	-3	-48	-3	-75	+3	-12
18	30	0	-9	0	+21	0	+33	0	+52	0	+84	-5	+8
				0	-30	0	-42	0	-61	0	-93	+5	-17
				-3	-27	-3	-39	-4	-57	-4	-89	+2	-14
30	50	0	-11	0	+25	0	+39	0	+62	0	+100	-6	+10
				0	-36	0	-50	0	-73	0	-111	+6	-21
				-4	-32	-4	-46	-5	-68	-5	-106	+3	-18
50	80	0	-13	0	+30	0	+46	0	+74	0	+120	-6	+13
				0	-43	0	-59	0	-87	0	-133	+6	-26
				-5	-38	-5	-54	-5	-82	-6	-127	+2	-22
80	120	0	-15	0	+35	0	+54	0	+87	0	+140	-6	+16
				0	-50	0	-69	0	-102	0	-155	+6	-31
				-5	-45	-6	-63	-6	-96	-7	-148	+1	-26
120	150	0	-18	0	+40	0	+63	0	+100	0	+160	-7	+18
				0	-58	0	-81	0	-118	0	-178	+7	-36
				-7	-51	-7	-74	-8	-110	-8	-170	+1	-30
150	180	0	-25	0	+40	0	+63	0	+100	0	+160	-7	+18
				0	-65	0	-88	0	-125	0	-185	+7	-43
				-8	-57	-10	-78	-10	-115	-11	-174	0	-36
180	250	0	-30	0	+46	0	+72	0	+115	0	+185	-7	+22
				0	-76	0	-102	0	-145	0	-215	+7	-52
				-10	-66	-12	-90	-13	-132	-13	-202	-1	-44
250	315	0	-35	0	+52	0	+81	0	+130	0	+210	-7	+25
				0	-87	0	-116	0	-165	0	-245	+7	-60
				-12	-75	-13	-103	-15	-150	-16	-229	-2	-51
315	400	0	-40	0	+57	0	+89	0	+140	0	+230	-7	+29
				0	-97	0	-129	0	-180	0	-270	+7	-69
				-13	-84	-15	-114	-17	-163	-18	-252	-4	-58
400	500	0	-45	0	+63	0	+97	0	+155	0	+250	-7	+33
				0	-108	0	-142	0	-200	0	-295	+7	-78
				-15	-93	-17	-125	-19	-181	-20	-275	-5	-66
500	630	0	-50	0	+70	0	+110	0	+175	0	+280	-	-
				0	-120	0	-160	0	-225	0	-330	-	-
				-16	-104	-19	-141	-21	-204	-22	-308	-	-

Table 8b

Housing tolerances and resultant fits

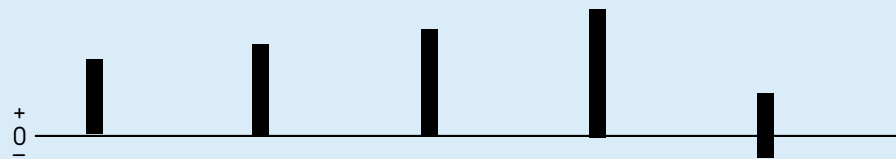

Housing Nominal bore diameter D		Bearing Outside diameter tolerance Δ_{Dmp}		Deviations of housing bore diameter, resultant fits										
				Tolerances										
				H7	H8		H9		H10		J6			
				Deviations (housing bore diameter)										
				Theoretical interference (+)/clearance (-)										
				Probable interference (+)/clearance (-)										
over	incl.	high	low											
mm		μm		μm										
630	800	0	-75	0	+80	0	+125	0	+200	0	+320	-	-	
				0	-155	0	-200	0	-275	0	-395	-	-	
				-22	-133	-27	-173	-30	-245	-33	-362	-	-	
800	1 000	0	-100	0	+90	0	+140	0	+230	0	+360	-	-	
				0	-190	0	-240	0	-330	0	-460	-	-	
				-27	-163	-33	-207	-39	-291	-43	-417	-	-	
1 000	1 250	0	-125	0	+105	0	+165	0	+260	0	+420	-	-	
				0	-230	0	-290	0	-385	0	-545	-	-	
				-33	-197	-41	-249	-48	-337	-53	-492	-	-	
1 250	1 600	0	-160	0	+125	0	+195	0	+310	0	+500	-	-	
				0	-285	0	-355	0	-470	0	-660	-	-	
				-40	-245	-51	-304	-60	-410	-67	-593	-	-	
1 600	2 000	0	-200	0	+150	0	+230	0	+370	0	+600	-	-	
				0	-350	0	-430	0	-570	0	-800	-	-	
				-50	-300	-62	-368	-74	-496	-83	-717	-	-	
2 000	2 500	0	-250	0	+175	0	+280	0	+440	0	+700	-	-	
				0	-425	0	-530	0	-690	0	-950	-	-	
				-59	-366	-77	-453	-91	-599	-103	-847	-	-	

Table 8c

Housing tolerances and resultant fits

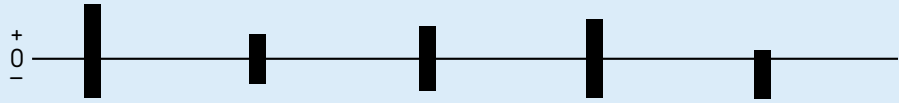

Housing Nominal bore diameter D		Bearing Outside diameter tolerance Δ_{Dmp}		Deviations of housing bore diameter, resultant fits Tolerances									
				J7	JS5		JS6	JS7		K5			
over	incl.	high	low	Deviations (housing bore diameter)									
				Theoretical interference (+)/clearance (-)									
				Probable interference (+)/clearance (-)									
mm		μm		μm									
6	10	0	-8	-7	+8	-3	+3	-4,5	+4,5	-7,5	+7,5	-5	+1
				+7	-16	+3	-11	+4,5	-12,5	+7,5	-15,5	+5	-9
				+4	-13	+1	-9	+3	-11	+5	-13	+3	-7
10	18	0	-8	-8	+10	-4	+4	-5,5	+5,5	-9	+9	-6	+2
				+8	-18	+4	-12	+5,5	-13,5	+9	-17	+6	-10
				+5	-15	+2	-10	+3	-11	+6	-14	+4	-8
18	30	0	-9	-9	+12	-4,5	+4,5	-6,5	+6,5	-10,5	+10,5	-8	+1
				+9	-21	+4,5	-13,5	+6,5	-15,5	+10,5	-19,5	+8	-10
				+6	-18	+2	-11	+4	-13	+7	-16	+6	-8
30	50	0	-11	-11	+14	-5,5	+5,5	-8	+8	-12,5	+12,5	-9	+2
				+11	-25	+5,5	-16,5	+8	-19	+12,5	-23,5	+9	-13
				+7	-21	+3	-14	+5	-16	+9	-20	+6	-10
50	80	0	-13	-12	+18	-6,5	+6,5	-9,5	+9,5	-15	+15	-10	+3
				+12	-31	+6,5	-19,5	+9,5	-22,5	+15	-28	+10	-16
				+7	-26	+3	-16	+6	-19	+10	-23	+7	-13
80	120	0	-15	-13	+22	-7,5	+7,5	-11	+11	-17,5	+17,5	-13	+2
				+13	-37	+7,5	-22,5	+11	-26	+17,5	-32,5	+13	-17
				+8	-32	+4	-19	+6	-21	+12	-27	+9	-13
120	150	0	-18	-14	+26	-9	+9	-12,5	+12,5	-20	+20	-15	+3
				+14	-44	+9	-27	+12,5	-30,5	+20	-38	+15	-21
				+7	-37	+4	-22	+7	-25	+13	-31	+10	-16
150	180	0	-25	-14	+26	-9	+9	-12,5	+12,5	-20	+20	-15	+3
				+14	-51	+9	-34	+12,5	-37,5	+20	-45	+15	-28
				+6	-43	+3	-28	+6	-31	+12	-37	+9	-22
180	250	0	-30	-16	+30	-10	+10	-14,5	+14,5	-23	+23	-18	+2
				+16	-60	+10	-40	+14,5	-44,5	+23	-53	+18	-32
				+6	-50	+4	-34	+6	-36	+13	-43	+12	-26
250	315	0	-35	-16	+36	-11,5	+11,5	-16	+16	-26	+26	-20	+3
				+16	-71	+11,5	-46,5	+16	+51	+26	-61	+20	-38
				+4	-59	+4	-39	+7	-42	+14	-49	+12	-30
315	400	0	-40	-18	+39	-12,5	+12,5	-18	+18	-28,5	+28,5	-22	+3
				+18	-79	+12,5	-52,5	+18	-58	+28,5	-68,5	+22	-43
				+5	-66	+4	-44	+7	-47	+15	-55	+14	-35
400	500	0	-45	-20	+43	-13,5	+13,5	-20	+20	-31,5	+31,5	-25	+2
				+20	-88	+13,5	-58,5	+20	-65	+31,5	-76,5	+25	-47
				+5	-73	+4	-49	+8	-53	+17	-62	+16	-38
500	630	0	-50	-	-	-14	+14	-22	+22	-35	+35	-	-
				-	-	+14	-64	+22	-72	+35	-85	-	-
				-	-	+4	-54	+9	-59	+19	-69	-	-

Table 8c

Housing tolerances and resultant fits

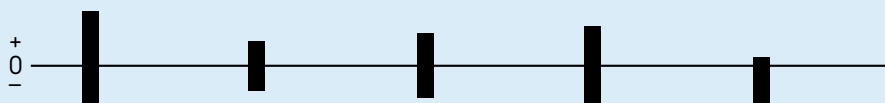

Housing Nominal bore diameter D		Bearing Outside diameter tolerance Δ_{Dmp}		Deviations of housing bore diameter, resultant fits Tolerances									
over	incl.	high	low	J7	JS5	JS6	JS7	K5					
				Deviations (housing bore diameter)									
				Theoretical interference (+)/clearance (-)									
				Probable interference (+)/clearance (-)									
mm		μm		μm									
630	800	0	-75	-	-	-16	+16	-25	+25	-40	+40	-	-
				-	-	+16	-91	+25	-100	+40	-115	-	-
				-	-	+4	-79	+8	-83	+18	-93	-	-
800	1 000	0	-100	-	-	-18	+18	-28	+28	-45	+45	-	-
				-	-	+18	-118	+28	-128	+45	-145	-	-
				-	-	+4	-104	+8	-108	+18	-118	-	-
1 000	1 250	0	-125	-	-	-21	+21	-33	+33	-52	+52	-	-
				-	-	+21	-146	+33	-158	+52	-177	-	-
				-	-	+4	-129	+9	-134	+20	-145	-	-
1 250	1 600	0	-160	-	-	-25	+25	-39	+39	-62	+62	-	-
				-	-	+25	-185	+39	-199	+62	-222	-	-
				-	-	+4	-164	+9	-169	+22	-182	-	-
1 600	2 000	0	-200	-	-	-30	+30	-46	+46	-75	+75	-	-
				-	-	+30	-230	+46	-246	+75	-275	-	-
				-	-	+5	-205	+11	-211	+25	-225	-	-
2 000	2 500	0	-250	-	-	-35	+35	-55	+55	-87	+87	-	-
				-	-	+35	-285	+55	-305	+87	-337	-	-
				-	-	+5	-255	+12	-262	+28	-278	-	-

Table 8d

Housing tolerances and resultant fits



Housing Nominal bore diameter D		Bearing Outside diameter tolerance Δ_{Dmp}		Deviations of housing bore diameter, resultant fits Tolerances									
				K6		K7		M5		M6		M7	
over	incl.	high	low	Deviations (housing bore diameter)									
				Theoretical interference (+)/clearance (-)									
				Probable interference (+)/clearance (-)									
mm		μm		μm									
6	10	0	-8	-7	+2	-10	+5	-10	-4	-12	-3	-15	0
				+7	-10	+10	-13	+10	-4	+12	-5	+15	-8
				+5	-8	+7	-10	+8	-2	+10	-3	+12	-5
10	18	0	-8	-9	+2	-12	+6	-12	-4	-15	-4	-18	0
				+9	-10	+12	-14	+12	-4	+15	-4	+18	-8
				+7	-8	+9	-11	+10	-2	+13	-2	+15	-5
18	30	0	-9	-11	+2	-15	+6	-14	-4	-17	-4	-21	0
				+11	-11	+15	-15	+14	-4	+17	-5	+21	-9
				+8	-8	+12	-12	+12	-2	+14	-2	+18	-6
30	50	0	-11	-13	+3	-18	+7	-16	-5	-20	-4	-25	0
				+13	-14	+18	-18	+16	-6	+20	-7	+25	-11
				+10	-11	+14	-14	+13	-3	+17	-4	+21	-7
50	80	0	-13	-15	+4	-21	+9	-19	-6	-24	-5	-30	0
				+15	-17	+21	-22	+19	-7	+24	-8	+30	-13
				+11	-13	+16	-17	+16	-4	+20	-4	+25	-8
80	120	0	-15	-18	+4	-25	+10	-23	-8	-28	-6	-35	0
				+18	-19	+25	-25	+23	-7	+28	-9	+35	-15
				+13	-14	+20	-20	+19	-3	+23	-4	+30	-10
120	150	0	-18	-21	+4	-28	+12	-27	-9	-33	-8	-40	0
				+21	-22	+28	-30	+27	-9	+33	-10	+40	-18
				+15	-16	+21	-23	+22	-4	+27	-4	+33	-11
150	180	0	-25	-21	+4	-28	+12	-27	-9	-33	-8	-40	0
				+21	-29	+28	-37	+27	-16	+33	-17	+40	-25
				+14	-22	+20	-29	+21	-10	+26	-10	+32	-17
180	250	0	-30	-24	+5	-33	+13	-31	-11	-37	-8	-46	0
				+24	-35	+33	-43	+31	-19	+37	-22	+46	-30
				+16	-27	+23	-33	+25	-13	+29	-14	+36	-20
250	315	0	-35	-27	+5	-36	+16	-36	-13	-41	-9	-52	0
				+27	-40	+36	-51	+36	-22	+41	-26	+52	-35
				+18	-31	+24	-39	+28	-14	+32	-17	+40	-23
315	400	0	-40	-29	+7	-40	+17	-39	-14	-46	-10	-57	0
				+29	-47	+40	-57	+39	-26	+46	-30	+57	-40
				+18	-36	+27	-44	+31	-18	+35	-19	+44	-27
400	500	0	-45	-32	+8	-45	+18	-43	-16	-50	-10	-63	0
				+32	-53	+45	-63	+43	-29	+50	-35	+63	-45
				+20	-41	+30	-48	+34	-20	+38	-23	+48	-30
500	630	0	-50	-44	0	-70	0	-	-	-70	-26	-96	-26
				+44	-50	+70	-50	-	-	+70	-24	+96	-24
				+31	-37	+54	-34	-	-	+57	-11	+80	-8

Table 8d

Housing tolerances and resultant fits

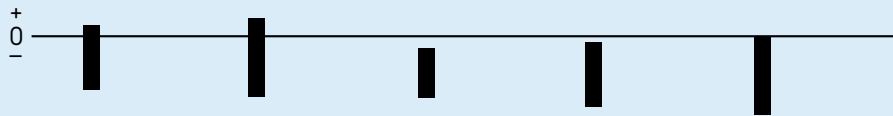

Housing Nominal bore diameter D		Bearing Outside diameter tolerance Δ_{Dmp}		Deviations of housing bore diameter, resultant fits Tolerances									
				K6		K7		M5		M6		M7	
over	incl.	high	low	Deviations (housing bore diameter)									
				Theoretical interference (+)/clearance (-)									
				Probable interference (+)/clearance (-)									
mm		μm		μm									
630	800	0	-75	-50	0	-80	0	-	-	-80	-30	-110	-30
				+50	-75	+80	-75	-	-	+80	-45	+110	-45
				+33	-58	+58	-53	-	-	+63	-28	+88	-23
800	1 000	0	-100	-56	0	-90	0	-	-	-90	-34	-124	-34
				+56	-100	+90	-100	-	-	+90	-66	+124	-66
				+36	-80	+63	-73	-	-	+70	-46	+97	-39
1 000	1 250	0	-125	-66	0	-105	0	-	-	-106	-40	-145	-40
				+66	-125	+105	-125	-	-	+106	-85	+145	-85
				+42	-101	+72	-92	-	-	+82	-61	+112	-52
1 250	1 600	0	-160	-78	0	-125	0	-	-	-126	-48	-173	-48
				+78	-160	+125	-160	-	-	+126	-112	+173	-112
				+48	-130	+85	-120	-	-	+96	-82	+133	-72
1 600	2 000	0	-200	-92	0	-150	0	-	-	-158	-58	-208	-58
				+92	-200	+150	-200	-	-	+150	-142	+208	-142
				+57	-165	+100	-150	-	-	+115	-107	+158	-92
2 000	2 500	0	-250	-110	0	-175	0	-	-	-178	-68	-243	-68
				+110	-250	+175	-250	-	-	+178	-182	+243	-182
				+67	-207	+116	-191	-	-	+135	-139	+184	-123

Table 8e

Housing tolerances and resultant fits

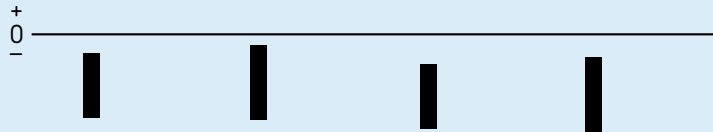

Housing Nominal bore diameter D		Bearing Outside diameter tolerance Δ_{Dmp}		Deviations of housing bore diameter, resultant fits Tolerances							
				N6		N7		P6		P7	
over	incl.	high	low	Deviations (housing bore diameter)							
				Theoretical interference (+)/clearance (-)							
				Probable interference (+)/clearance (-)							
mm		μm		μm							
6	10	0	-8	-16	-7	-19	-4	-21	-12	-24	-9
				+16	-1	+19	-4	+21	+4	+24	+1
				+14	+1	+16	-1	+19	+6	+21	+4
10	18	0	-8	-20	-9	-23	-5	-26	-15	-29	-11
				+20	+1	+23	-3	+26	+7	+29	+3
				+18	+3	+20	0	+24	+9	+26	+6
18	30	0	-9	-24	-11	-28	-7	-31	-18	-35	-14
				+24	+2	+28	-2	+31	+9	+35	+5
				+21	+5	+25	+1	+28	+12	+32	+8
30	50	0	-11	-28	-12	-33	-8	-37	-21	-42	-17
				+28	+1	+33	-3	+37	+10	+42	+6
				+25	+4	+29	+1	+34	+13	+38	+10
50	80	0	-13	-33	-14	-39	-9	-45	-26	-51	-21
				+33	+1	+39	-4	+45	+13	+51	+8
				+29	+5	+34	+1	+41	+17	+46	+13
80	120	0	-15	-38	-16	-45	-10	-52	-30	-59	-24
				+38	+1	+45	-5	+52	+15	+59	+9
				+33	+6	+40	0	+47	+20	+54	+14
120	150	0	-18	-45	-20	-52	-12	-61	-36	-68	-28
				+45	+2	+52	-6	+61	+18	+68	+10
				+39	+8	+45	+1	+55	+24	+61	+17
150	180	0	-25	-45	-20	-52	-12	-61	-36	-68	-28
				+45	-5	+52	-13	+61	+11	+68	+3
				+38	+2	+44	-5	+54	+18	+60	+11
180	250	0	-30	-51	-22	-60	-14	-70	-41	-79	-33
				+51	-8	+60	-16	+70	+11	+79	+3
				+43	0	+50	-6	+62	+19	+69	+13
250	315	0	-35	-57	-25	-66	-14	-79	-47	-88	-36
				+57	-10	+66	-21	+79	+12	+88	+1
				+48	-1	+54	-9	+70	+21	+76	+13
315	400	0	-40	-62	-26	-73	-16	-87	-51	-98	-41
				+62	-14	+73	-24	+87	+11	+98	+1
				+51	-3	+60	-11	+76	+22	+85	+14
400	500	0	-45	-67	-27	-80	-17	-95	-55	-108	-45
				+67	-18	+80	-28	+95	+10	+108	0
				+55	-6	+65	-13	+83	+22	+93	+15
500	630	0	-50	-88	-44	-114	-44	-122	-78	-148	-78
				+88	-6	+114	-6	+122	+28	+148	+28
				+75	+7	+98	+10	+109	+41	+132	+44

Table 8e

Housing tolerances and resultant fits



Housing Nominal bore diameter D		Bearing Outside diameter tolerance Δ_{Dmp}		Deviations of housing bore diameter, resultant fits Tolerances							
				N6		N7		P6		P7	
over	incl.	high	low	Deviations (housing bore diameter)							
				Theoretical interference (+)/clearance (-)							
				Probable interference (+)/clearance (-)							
mm		μm		μm							
630	800	0	-75	-100	-50	-130	-50	-138	-88	-168	-88
				+100	-25	+130	-25	+138	+13	+168	+13
				+83	-8	+108	-3	+121	+30	+146	+35
800	1 000	0	-100	-112	-56	-146	-56	-156	-100	-190	-100
				+112	-44	+146	-44	+156	0	+190	0
				+92	-24	+119	-17	+136	+20	+163	+27
1 000	1 250	0	-125	-132	-66	-171	-66	-186	-120	-225	-120
				+132	-59	+171	-59	+186	-5	+225	-5
				+108	-35	+138	-26	+162	+19	+192	+28
1 250	1 600	0	-160	-156	-78	-203	-78	-218	-140	-265	-140
				+156	-82	+203	-82	+218	-20	+265	-20
				+126	-52	+163	-42	+188	+10	+225	+20
1 600	2 000	0	-200	-184	-92	-242	-92	-262	-170	-320	-170
				+184	-108	+242	-108	+262	-30	+320	-30
				+149	-73	+192	-58	+227	+5	+270	+20
2 000	2 500	0	-250	-220	-110	-285	-110	-305	-195	-370	-195
				+220	-140	+285	-140	+305	-55	+370	-55
				+177	-97	+226	-81	+262	-12	+311	+4

Application of bearings

Dimensional, form and running accuracy of bearing seatings and abutments

The accuracy of cylindrical bearing seatings on shafts and in housing bores, of seatings for thrust bearing washers and of the support surfaces (abutments for bearings provided by shaft and housing shoulders etc.) should correspond to the accuracy of the bearings used. In the following, guideline values for the dimensional, form and running accuracy are provided. These should be followed when machining the seatings and abutments.

Dimensional tolerances

For bearings made to Normal tolerances, the dimensional accuracy of cylindrical seatings on the shaft should be at least to grade 6 and in the housing at least to grade 7. Where adapter or withdrawal sleeves are used, wider diameter tolerances (grades 9 or 10) can be permitted than for bearing seatings (→ **table 9**). The numerical values of standard tolerance grades IT to ISO 286-1:1988 can be found in **table 10**. For bearings with higher accuracy, correspondingly better grades should be used.

Tolerances for cylindrical form

The cylindricity tolerances as defined in ISO 1101:2004 should be 1 to 2 IT grades better than the prescribed dimensional tolerance, depending on requirements. For example, if a bearing shaft seating has been machined to tolerance m6, then the accuracy of form should be to IT5 or IT4. The tolerance value t_1 for cylindricity is obtained for an assumed shaft diameter of 150 mm from $t_1 = IT5/2 = 18/2 = 9 \mu\text{m}$. However, the tolerance t_1 is for a radius, hence $2 \times t_1$ applies for the shaft diameter.

Table 11, page 196, provides guideline values for the cylindrical form tolerance and the total runout tolerance for the different bearing tolerance classes.

When bearings are to be mounted on adapter or withdrawal sleeves, the cylindricity of the sleeve seating should be IT5/2 (for h9) or IT7/2 (for h10) (→ **table 9**).

Tolerances for perpendicularity

Abutments for bearing rings should have a rectangularity tolerance as defined in ISO 1101:2004, which is better by at least one IT grade than the diameter tolerance of the associated cylindrical seating. For thrust bearing washer seatings, the tolerance for perpendicularity should not exceed the values of IT5. Guideline values for the tolerance for rectangularity and for the total axial runout can be found in **table 11, page 196**.

Table 9

Shaft tolerances for bearings mounted on sleeves

Shaft diameter d		Diameter and form tolerances					
		h9 Deviations high low		IT5 ¹⁾ max	h10 Deviations high low		IT7 ¹⁾ max
over	incl.						
mm		µm					
10	18	0	-43	8	0	-70	18
18	30	0	-52	9	0	-84	21
30	50	0	-62	11	0	-100	25
50	80	0	-74	13	0	-120	30
80	120	0	-87	15	0	-140	35
120	180	0	-100	18	0	-160	40
180	250	0	-115	20	0	-185	46
250	315	0	-130	23	0	-210	52
315	400	0	-140	25	0	-230	57
400	500	0	-155	27	0	-250	63
500	630	0	-175	32	0	-280	70
630	800	0	-200	36	0	-320	80
800	1 000	0	-230	40	0	-360	90
1 000	1 250	0	-260	47	0	-420	105

¹⁾The recommendation is for IT5/2 or IT7/2, because the tolerance zone t is a radius, however in the table above the values relate to a nominal shaft diameter and are therefore not halved

Table 10

ISO tolerance grades for dimensions (lengths, widths, diameters etc.)

Nominal dimension over incl.		Tolerance grades											
		IT1 max	IT2	IT3	IT4	IT5	IT6	IT7	IT8	IT9	IT10	IT11	IT12
mm		µm											
1	3	0,8	1,2	2	3	4	6	10	14	25	40	60	100
3	6	1	1,5	2,5	4	5	8	12	18	30	48	75	120
6	10	1	1,5	2,5	4	6	9	15	22	36	58	90	150
10	18	1,2	2	3	5	8	11	18	27	43	70	110	180
18	30	1,5	2,5	4	6	9	13	21	33	52	84	130	210
30	50	1,5	2,5	4	7	11	16	25	39	62	100	160	250
50	80	2	3	5	8	13	19	30	46	74	120	190	300
80	120	2,5	4	6	10	15	22	35	54	87	140	220	350
120	180	3,5	5	8	12	18	25	40	63	100	160	250	400
180	250	4,5	7	10	14	20	29	46	72	115	185	290	460
250	315	6	8	12	16	23	32	52	81	130	210	320	520
315	400	7	9	13	18	25	36	57	89	140	230	360	570
400	500	8	10	15	20	27	40	63	97	155	250	400	630
500	630	–	–	–	–	32	44	70	110	175	280	440	700
630	800	–	–	–	–	36	50	80	125	200	320	500	800
800	1 000	–	–	–	–	40	56	90	140	230	360	560	900
1 000	1 250	–	–	–	–	47	66	105	165	260	420	660	1050
1 250	1 600	–	–	–	–	55	78	125	195	310	500	780	1250
1 600	2 000	–	–	–	–	65	92	150	230	370	600	920	1 500
2 000	2 500	–	–	–	–	78	110	175	280	440	700	1 100	1 750

Table 11

Accuracy of form and position for bearing seatings on shafts and in housings

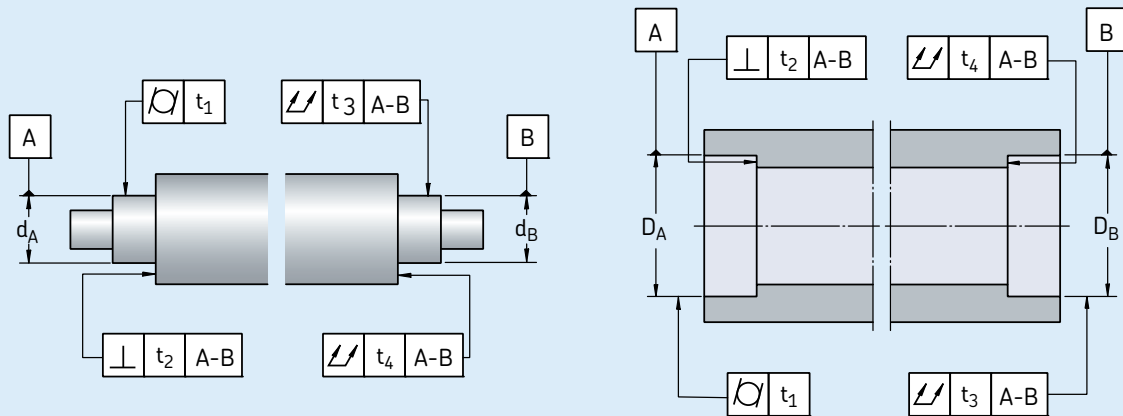

Surface Characteristic	Symbol for characteristic	tolerance zone	Permissible deviations Bearings of tolerance class ¹⁾			
			Normal, CLN	P6	P5	
Cylindrical seating						
Cylindricity		t ₁	IT5/2	IT4/2	IT3/2	IT2/2
Total radial runout		t ₃	IT5/2	IT4/2	IT3/2	IT2/2
Flat abutment						
Rectangularity		t ₂	IT5	IT4	IT3	IT2
Total axial runout		t ₄	IT5	IT4	IT3	IT2
Explanation						
	For normal demands	For special demands with respect to running accuracy or even support				

¹⁾For bearings of higher accuracy (tolerance class P4 etc.) please refer to SKF catalogue "High-precision bearings"

Tolerances for tapered journal seatings

When a bearing is mounted directly onto a tapered shaft seating, the seating diameter tolerance can be wider than in the case of cylindrical seatings. **Fig. 18** shows a grade 9 diameter tolerance, while the form tolerance stipulations are the same as for a cylindrical shaft seating. SKF recommendations for tapered shaft seatings for rolling bearings are as follows.

- The permissible deviation of the taper incline is a \pm tolerance in accordance with IT7/2 based on the bearing width B (\rightarrow **fig. 18**). The value can be determined by

$$\Delta_k = IT7/2 B$$

The permissible range of dispersion (variation of the taper incline) thus becomes

$$V_k = 1/k \pm IT7/2 B$$

where

V_k = the permissible range of dispersion of the taper incline

Δ_k = the permissible deviation of the taper incline

k = factor for the taper
 12 for taper 1: 12
 30 for taper 1: 30

B = bearing width, mm

IT7 = the value of the tolerance grade, based on the bearing width, mm

- The straightness tolerance is IT5/2, based on the diameter d and is defined as: "In each axial plane through the tapered surface of the shaft, the tolerance zone is limited by two parallel lines a distance "t" apart."
- The radial deviation from circularity is IT5/2, based on the diameter d and is defined as: "In each radial plane along the tapered surface of the shaft, the tolerance zone is limited by two concentric circles a distance "t" apart." When particularly stringent running accuracy requirements are stipulated, IT4/2 is to apply instead.

The best way to check that the taper is within the recommended tolerances is to measure with special taper gauges, based on two saddles. More practical methods, but less accurate, are to use ring gauges, taper gauges or sine bars.

Fig. 18

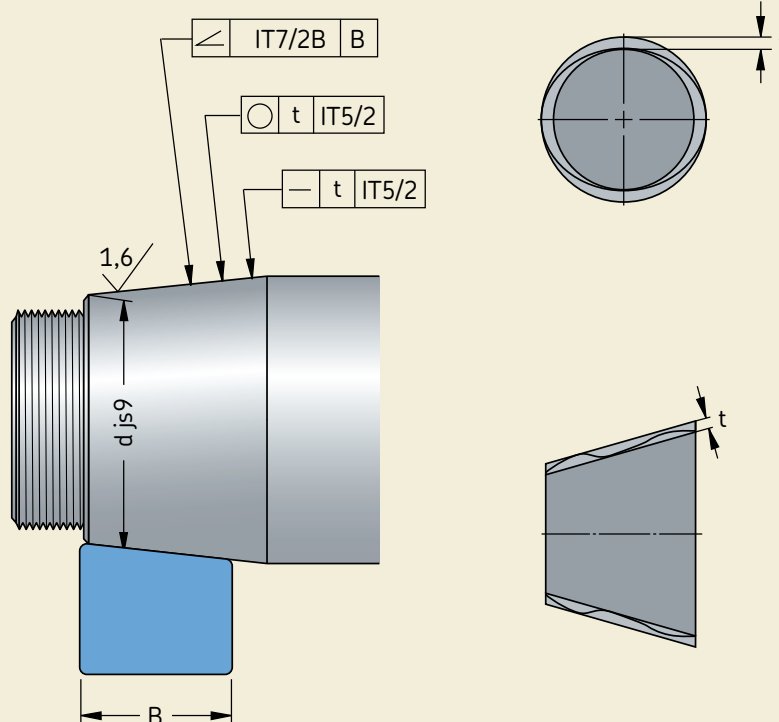

Application of bearings

Surface roughness of bearing seatings

The roughness of bearing seating surfaces does not have the same degree of influence on bearing performance as the dimensional, form and running accuracies. However, a desired interference fit is much more accurately obtained the smoother the mating surfaces are. For less critical bearing arrangements relatively large surface roughness is permitted.

For bearing arrangements where demands for accuracy are high, guideline values for the mean surface roughness R_a are provided in **table 12** for different dimensional accuracies of the bearing seatings. These recommendations apply to ground seatings, which are normally assumed for shaft seatings.

Raceways on shafts and in housings

Raceways machined in associated components for cylindrical roller bearings with only one ring and for cylindrical roller and cage thrust assemblies, must have a hardness of between 58 and 64 HRC if the load carrying capacity of the bearing or assembly is to be fully exploited.

The surface roughness should be $R_a \leq 0,2 \mu\text{m}$ or $R_z \leq 1 \mu\text{m}$. For less demanding applications, lower hardness and rougher surfaces may be used.

The out-of-round and deviation from cylindrical form must not exceed 25 and 50 %, respectively, of the actual diameter tolerance of the raceway.

The permissible axial runouts of raceways for thrust assemblies are the same as for the shaft and housing washers of thrust bearings, shown in **table 10, page 132**.

Suitable materials for the seatings include steels for through-hardening, e.g. 100Cr6 to ISO 683-17:1999, steels for case-hardening, e.g. 20Cr3 or 17MnCr5 to ISO 683-17:1999), as well as steels for induction-hardening that can be partially hardened.

The case depth that is recommended for raceways machined in associated components depends on various factors including the dynamic and static load ratios (P/C and P_0/C_0 respectively) as well as the core hardness, and it is difficult to generalize. For example, under conditions of purely static load up to the magnitude of the basic static load rating and with a core hardness of 350 HV, the recommended case depth is in the order of 0,1 times the roll-

ing element diameter. Smaller case depths are permitted for dynamic loads. For additional information, please consult the SKF application engineering service.

Table 12

Guideline values for surface roughness of bearing seatings

Diameter of seatings		Recommended R_a value for ground seatings (Roughness grade numbers)		
		Diameter tolerance to		
d (D) ¹⁾		IT7	IT6	IT5
over	incl.			
mm		μm		
–	80	1,6 (N7)	0,8 (N6)	0,4 (N5)
80	500	1,6 (N7)	1,6 (N7)	0,8 (N6)
500	1 250	3,2 (N8) ²⁾	1,6 (N7)	1,6 (N7)

¹⁾ For diameters > 1 250 mm consult the SKF application engineering service

²⁾ When using the oil injection method for mounting R_a should not exceed 1,6 μm

Axial location of bearings

An interference fit alone is inadequate for the axial location of a bearing ring. As a rule, therefore, some suitable means of axially securing the ring is needed.

Both rings of a locating bearing should be axially secured on both sides.

For non-locating bearings that are of a non-separable design, the ring having the tighter fit – usually the inner ring – should be axially secured; the other ring must be free to move axially with respect to its seating, except for CARB bearings where both the rings are axially secured.

For non-locating bearings that are of a separable design, e.g. cylindrical roller bearings, both the rings are axially secured.

For “cross-located” bearing arrangements each bearing ring needs only be axially secured on one side.

Methods of location

Bearings with a cylindrical bore

Bearing rings having an interference fit are generally mounted so that the ring abuts a shoulder on the shaft or in the housing on one side (→ **fig. 19**). On the opposite side, inner rings are normally secured using lock nuts, as shown in the section “Lock nuts”, starting on **page 1007**, e.g. of KM + MB type (→ **fig. 19**) or by end plates (→ **fig. 20**) attached to the shaft end. Outer rings are usually retained by

Fig. 20

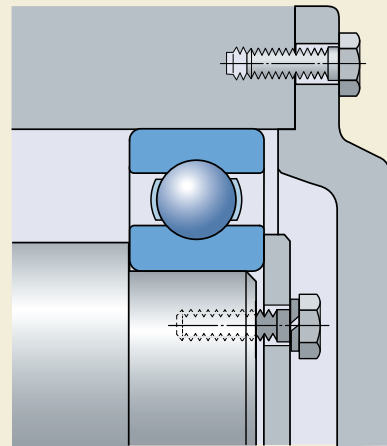

Fig. 21

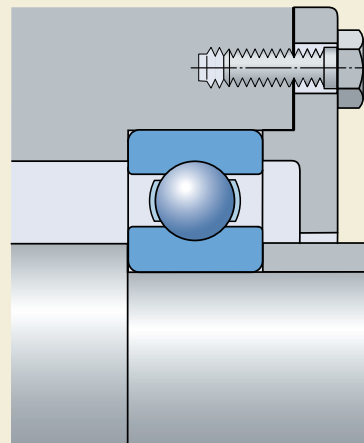

Fig. 19

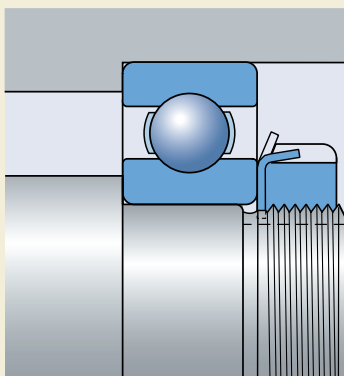
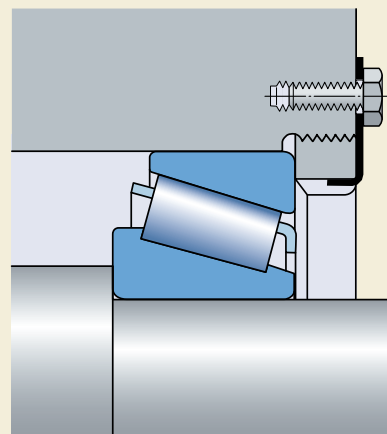

Fig. 22



Application of bearings

the housing end cover (→ **fig. 21**) or possibly, in special cases, by a threaded ring (→ **fig. 22**).

Instead of integral shaft or housing shoulders, it is frequently more convenient to use spacer sleeves or collars between the bearing rings or between a bearing ring and an adjacent component, e.g. a gear (→ **fig. 23**).

The use of snap rings for the axial location of rolling bearings saves space, permits rapid mounting and dismounting, and simplifies the machining of shafts and housing bores. If moderate or heavy axial loads have to be supported an abutment collar should be inserted between the bearing ring and the snap ring, so that the snap ring is not subjected to excessive bending moments (→ **fig. 24**). The usual axial play between the snap ring and snap ring groove can be reduced, if necessary, by choosing suitable tolerances for the abutment collar or by using shims. Bearings with a snap ring groove in the outer ring (→ **fig. 23**) can be secured in a very simple and space-saving manner using a snap ring (→ section “Deep groove ball bearings”, starting on **page 287**).

Other methods of axial location which are suitable, especially for high precision bearing arrangements involve the use of press fits, e.g. in the form of stepped sleeve arrangements. Additional details can be found in the SKF catalogue “High-precision bearings”.

Fig. 23

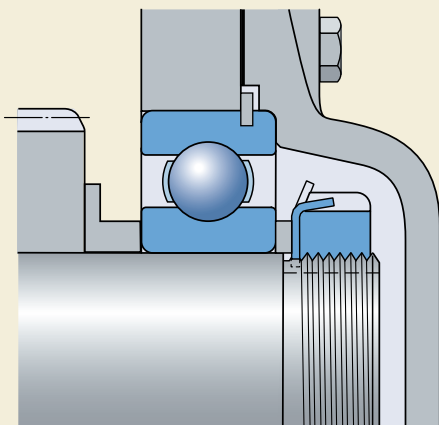
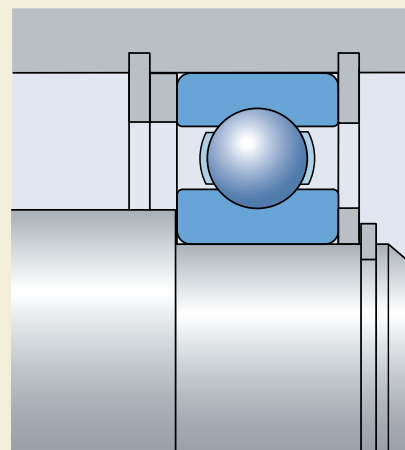

Fig. 24



Bearings with a tapered bore

Bearings with a tapered bore mounted directly on tapered journals are generally secured on the shaft by a lock nut (→ **fig. 25**).

When using an adapter sleeve on a stepped shaft, the lock nut positions the bearing relative to the sleeve, and a spacer ring is inserted between the shaft shoulder and inner ring on the other side (→ **fig. 26**). Where smooth shafts without integral abutments are used (→ **fig. 27**), the friction between the shaft and sleeve governs the axial load carrying capacity of the bearing, see sections

- “Self-aligning ball bearings” on **page 478** and
- “Spherical roller bearings” on **page 708**.

Where bearings are mounted on a withdrawal sleeve, an abutment, e.g. a spacer ring, which is frequently designed as a labyrinth ring, must support the inner ring. The withdrawal sleeve itself is axially located by an end plate or a lock nut (→ **fig. 28**).

Fig. 26

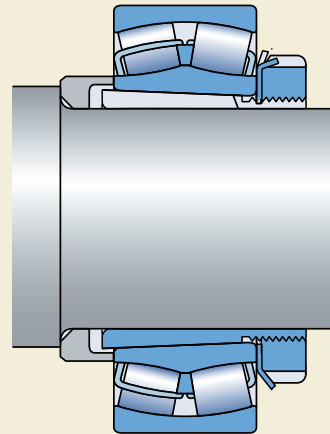

Fig. 27

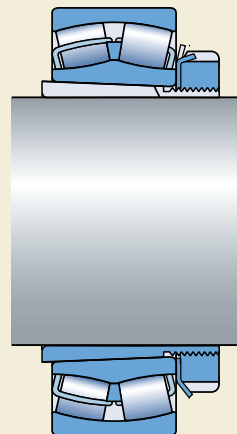

Fig. 25

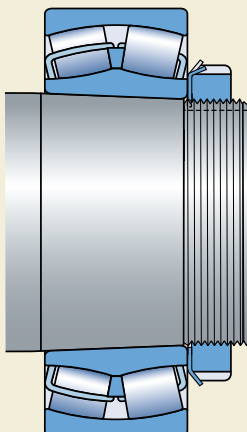
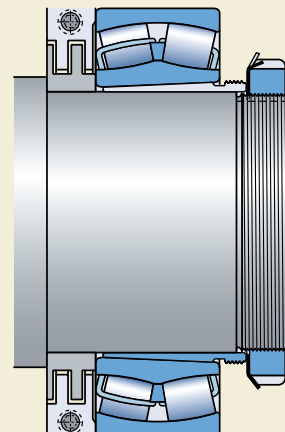

Fig. 28



Abutment and fillet dimensions

The dimensions of components adjacent to the bearing (shaft and housing shoulders, spacer sleeves etc.) must be such that sufficient support is provided for the bearing rings, but there must be no contact between the rotating parts of the bearing and a stationary component. Appropriate abutment and fillet dimensions are quoted for each bearing listed in the product tables.

The transition between the bearing seating and shaft or housing shoulder, may either take the form of a simple fillet according to the dimensions r_a and r_b in the product tables, or be relieved in the form of an undercut. **Table 13** provides suitable dimensions for the relieved fillets.

The greater the fillet radius (for the smooth form curve), the more favourable is the stress distribution in the shaft fillet area. For heavily loaded shafts, therefore, a large radius is generally required. In such cases a spacing collar should be provided between the inner ring and shaft shoulder to provide a sufficiently large support surface for the bearing ring. The side of the collar facing the shaft shoulder should be relieved so that it does not contact the shaft fillet (→ **fig. 29**).

Table 13

Relieved fillets

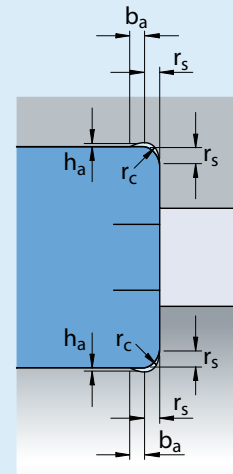

Bearing chamfer dimension r_s	Fillet dimensions		
	b_a	h_a	r_c
mm	mm		
1	2	0,2	1,3
1,1	2,4	0,3	1,5
1,5	3,2	0,4	2
2	4	0,5	2,5
2,1	4	0,5	2,5
3	4,7	0,5	3
4	5,9	0,5	4
5	7,4	0,6	5
6	8,6	0,6	6
7,5	10	0,6	7
9,5	12	0,6	9

Fig. 29

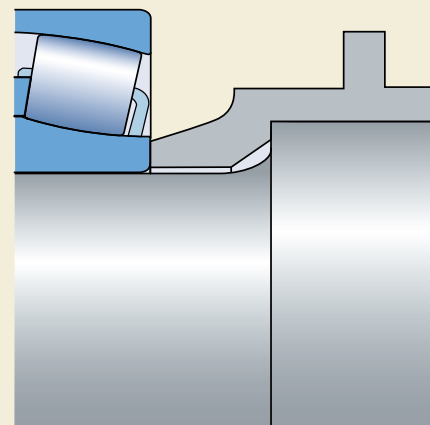

CARB toroidal roller bearings

CARB bearings can accommodate axial expansion of the shaft, within the bearing. To be sure that these axial displacements of the shaft with respect to the housing can take place it is necessary to provide space on both sides of the bearing (→ **fig. 30**).

Additional information can be found in the section “CARB toroidal roller bearings”, starting on **page 779**.

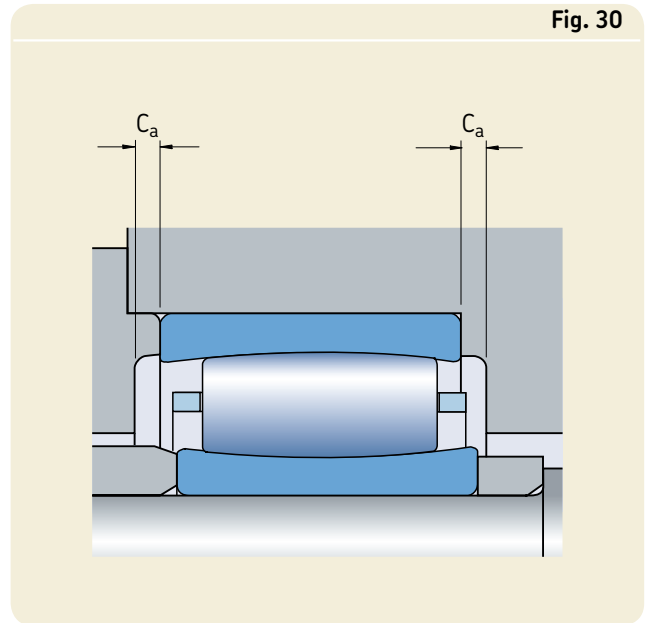

Designing associated components

Particularly where large bearings are involved, it is often necessary to make provisions during the bearing arrangement design stage, to facilitate mounting and dismounting of the bearing, or even to make it possible at all. If, for example, slots or recesses are machined in the shaft and/or housing shoulders, it is possible to apply withdrawal tools (→ **fig. 31**). Threaded holes in the housing shoulders also enable the use of screws to push the bearing from its seating (→ **fig. 32**).

If the oil injection method is to be used to mount or dismount bearings on a tapered seating, or to dismount bearings from a cylindrical seating, it is necessary to provide ducts and grooves in the shaft (→ **fig. 33**). The distance of the oil distribution groove from the side of the bearing from which mounting or dismounting is to be undertaken should be about one third of the seating width. Recommended dimensions for the appropriate grooves, ducts and threaded holes to connect the oil supply can be found in **tables 14** and **15**.

Fig. 31

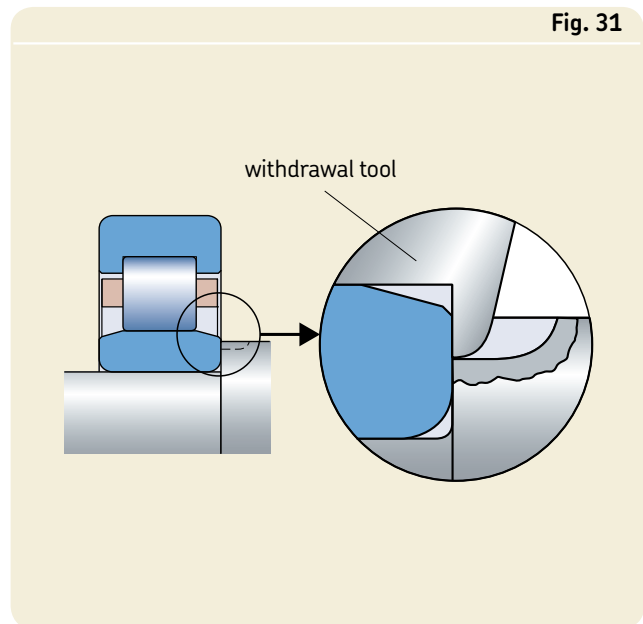

Fig. 32

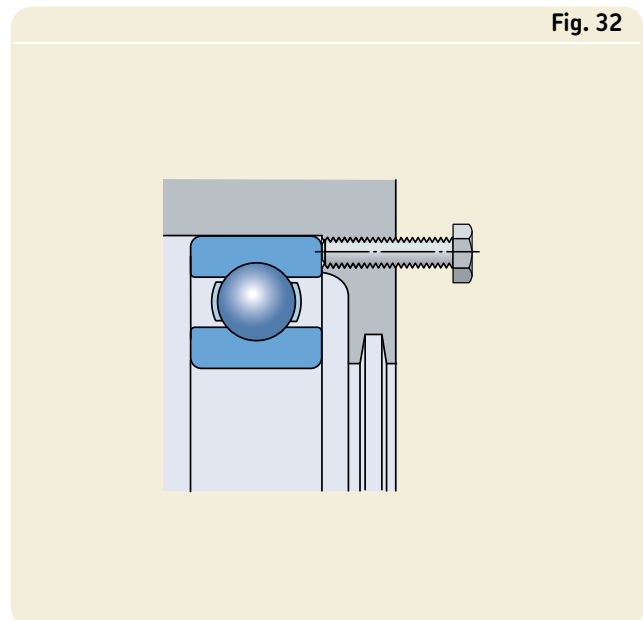

Fig. 33

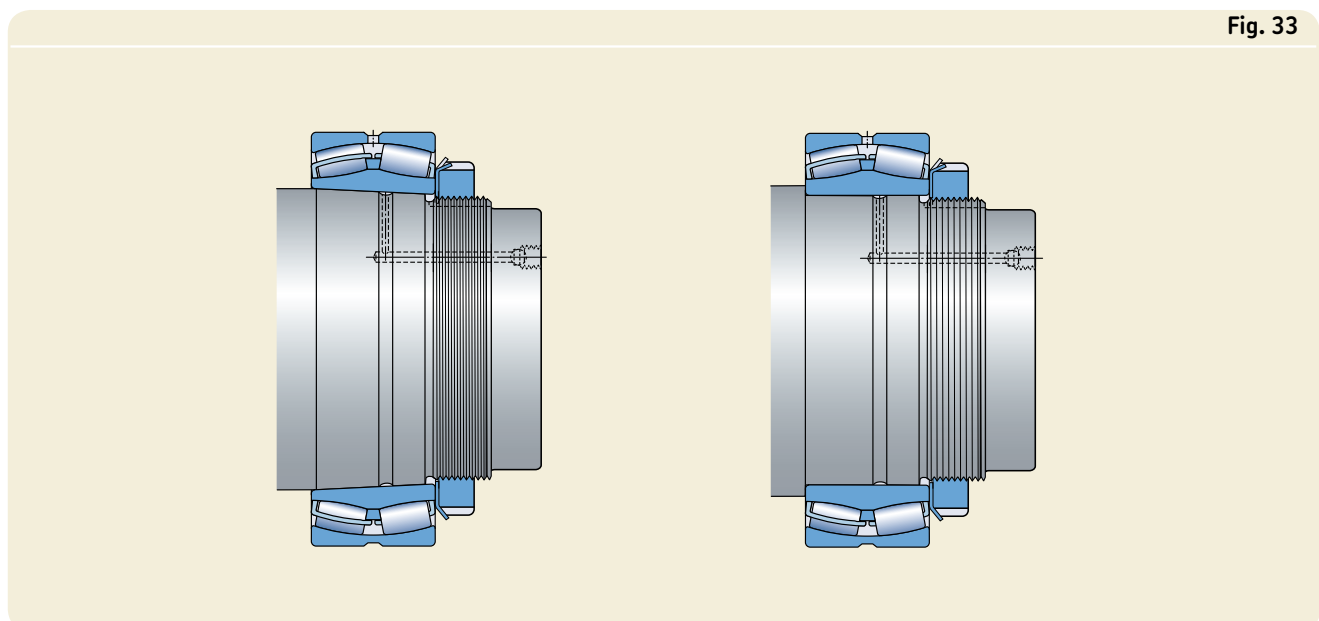
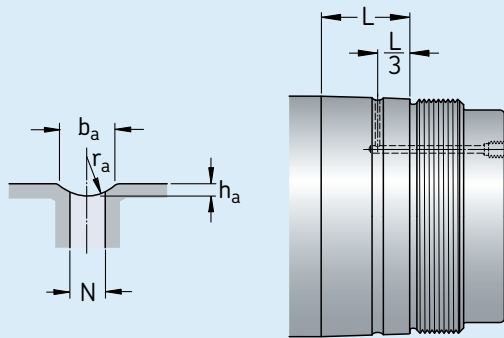

Table 14

Recommended dimensions for oil supply ducts and grooves



Seating diameter		Dimensions			
over	incl.	b_a	h_a	r_a	N
mm		mm			
–	100	3	0,5	2,5	2,5
100	150	4	0,8	3	3
150	200	4	0,8	3	3
200	250	5	1	4	4
250	300	5	1	4	4
300	400	6	1,25	4,5	5
400	500	7	1,5	5	5
500	650	8	1,5	6	6
650	800	10	2	7	7
800	1 000	12	2,5	8	8

L = width of bearing seating

Table 15

Design and recommended dimensions for threaded holes for connecting oil supply

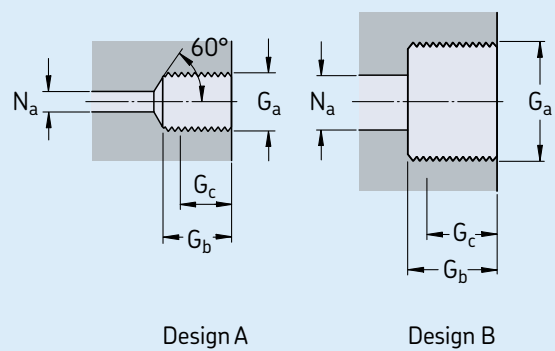

Thread	Design	Dimensions		N_a
G_a		G_b	$G_c^{1)}$ max	
–	–	mm		
M 6	A	10	8	3
G 1/8	A	12	10	3
G 1/4	A	15	12	5
G 3/8	B	15	12	8
G 1/2	B	18	14	8
G 3/4	B	20	16	8

¹⁾ Effective threaded length

Bearing preload

Depending on the application it may be necessary to have either a positive or a negative operational clearance in the bearing arrangement. In the majority of applications, the operational clearance should be positive, i.e. when in operation, the bearing should have a residual clearance, however slight (→ section “Bearing internal clearance” on **page 137**).

However, there are many cases, e.g. machine tool spindle bearings, pinion bearings in automotive axle drives, bearing arrangements of small electric motors, or bearing arrangements for oscillating movement, where a negative operational clearance, i.e. a preload, is needed to enhance the stiffness of the bearing arrangement or to increase running accuracy. The application of a preload, e.g. by springs, is also recommended where bearings are to operate without load or under very light load and at high speeds. In these cases, the preload serves to provide a minimum load on the bearing and prevent bearing damage as a result of sliding movements of the rolling elements (→ section “Requisite minimum load” on **page 75**).

Types of preload

Depending on the type of bearing the preload may be either radial or axial. Cylindrical roller bearings, for example, because of their design, can only be preloaded radially, and thrust ball and cylindrical roller thrust bearings can only be preloaded axially. Single row angular con-

Fig. 34

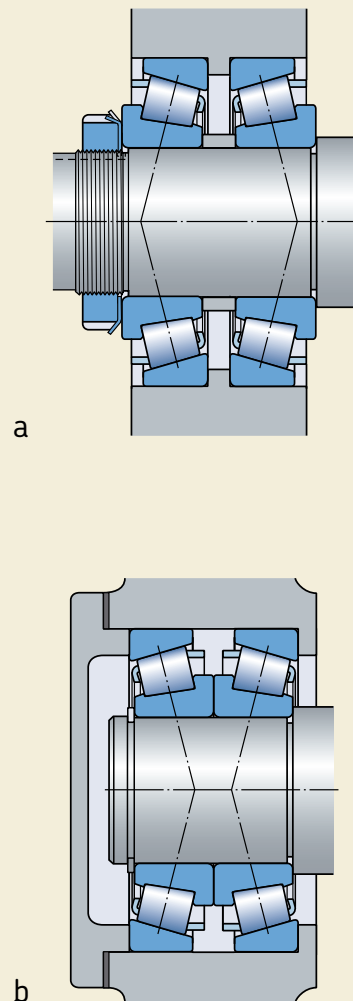
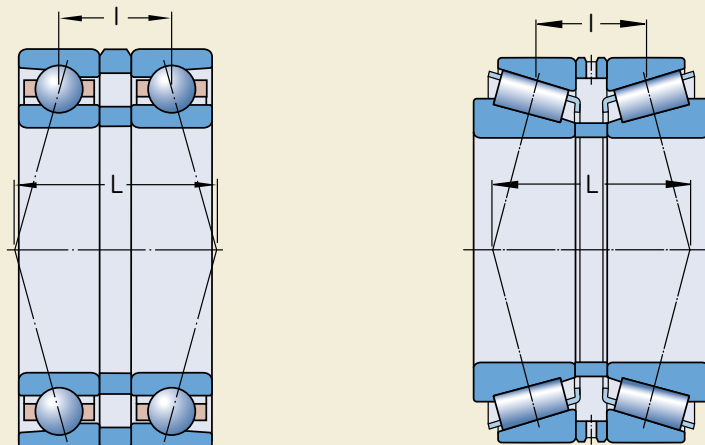

Fig. 35



tact ball bearings and taper roller bearings (→ **fig. 34**), which are normally subjected to axial preload, are generally mounted together with a second bearing of the same type in a back-to-back (**a**) or face-to-face (**b**) arrangement. Deep groove ball bearings are also generally preloaded axially, to do so, the bearings should have a greater radial internal clearance than Normal (e.g. C3) so that, as with angular contact ball bearings, a contact angle which is greater than zero will be produced.

For both taper roller and angular contact ball bearings, the distance L between the pressure centres is longer when the bearings are arranged back-to-back (→ **fig. 35**) and shorter when they are arranged face-to-face (→ **fig. 36**) than the distance l between the bearing centres. This means that bearings arranged back-to-back can accommodate relatively large tilting moments even if the distance between the bearing centres is relatively short. The radial forces resulting from the moment load and the deformation caused by these in the bearings are smaller than for bearings arranged face-to-face.

If in operation the shaft becomes warmer than the housing, the preload which was adjusted (set) at ambient temperature during mounting will increase, the increase being greater for face-to-face than for back-to-back arrangements. In both cases the thermal expansion in the radial direction serves to reduce clearance or increase preload. This tendency is increased by the thermal expansion in the axial direction when the bearings are face-to-face, but is

reduced for back-to-back arrangements. For back-to-back arrangements only, for a given distance between the bearings and when the coefficient of thermal expansion is the same for the bearings and associated components, the radial and axial thermal expansions will cancel each other out so that the preload will not change.

Fig. 36

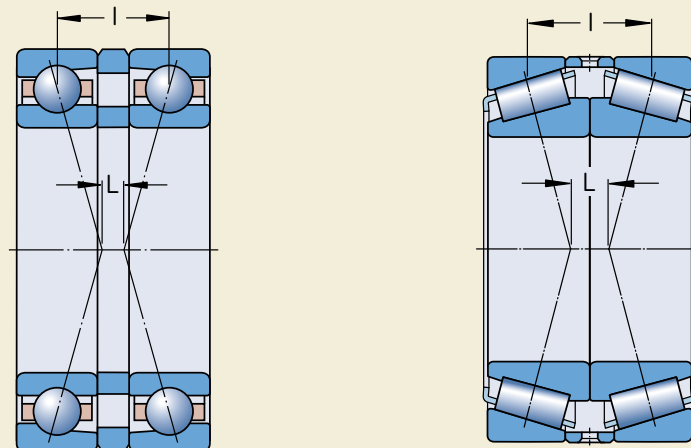

Application of bearings

Effects of bearing preload

The main reasons to apply bearing preload are to

- enhance stiffness
- reduce running noise
- enhance the accuracy of shaft guidance
- compensate for wear and settling (bedding down) processes in operation
- provide long service life.

High stiffness

Bearing stiffness (in $\text{kN}/\mu\text{m}$) is defined as the ratio of the force acting on the bearing to the elastic deformation in the bearing. The elastic deformation caused by a load in preloaded bearings is smaller for a given load range than in bearings which are not preloaded.

Quiet running

The smaller the operational clearance in a bearing, the better the guidance of the rolling elements in the unloaded zone and the quieter the bearing in operation.

Accurate shaft guidance

Preloaded bearings provide more accurate shaft guidance because preload restricts the ability of the shaft to deflect under load. For example, the more accurate guidance and the increased stiffness afforded by preloaded pinion and differential bearings means that the gear mesh will be kept accurate and remain constant, and that additional dynamic forces will be minimized. As a result, operation will be quiet and the gear mesh will have a long service life.

Compensating for wear and settling

Wear and settling processes in a bearing arrangement during operation increase the clearance but this can be compensated for by preload.

Long service life

In certain applications preloaded bearing arrangements can enhance operational reliability and increase service life. A properly dimensioned preload can have a favourable influence on the load distribution in the bearings and therefore on service life (→ section “Maintaining the correct preload” on **page 216**).

Determining preload force

Preload may be expressed as a force or as a path (distance), although the preload force is the primary specification factor. Depending on the adjustment method, preload is also indirectly related to the frictional moment in the bearing.

Empirical values for the optimum preload can be obtained from proven designs and can be applied to similar designs. For new designs SKF recommends calculating the preload force and checking its accuracy by testing. As generally not all influencing factors of the actual operation are accurately known, corrections may be necessary in practice. The reliability of the calculation depends above all on how well the assumptions made regarding the temperature conditions in operation and the elastic behaviour of the associated components – most importantly the housing – coincide with the actual conditions.

When determining the preload, the preload force required to give an optimum combination of stiffness, bearing life and operational reliability should be calculated first. Then calculate the preload force to be used when adjusting the bearings during mounting. When mounting, the bearings should be at ambient temperature and not subjected to an operating load.

The appropriate preload at normal operating temperature depends on the bearing load. An angular contact ball bearing or a taper roller bearing can accommodate radial and axial loads simultaneously. Under radial load, a force acting in the axial direction will be produced in the bearing, and this must generally be accommodated by a second bearing, which faces in the opposite direction to the first one. Purely radial displacement of one bearing ring in relation to the other will mean that half of the bearing circumference (i.e. half of the rolling elements) is under load and the axial force produced in the bearing will be

$F_a = R F_r$ for single row angular contact ball bearings or

$F_a = 0,5 F_r/Y$ for single row taper roller bearings

where F_r is the radial bearing load (→ **fig. 37**).

The values of the variable R which takes into account the contact conditions inside angular contact ball bearings has to be determined according to the guidelines provided in the section “Determining axial force for bearings

mounted singly or paired in tandem”, starting on **page 415**.

The values of the axial factor Y for taper roller bearings can be found in the product tables.

When a single bearing is subjected to a radial load F_r , an external axial force F_a of the above magnitude must be applied if the prerequisite for the basic load ratings (half of the bearing circumference under load) is to be fulfilled. If the applied external force is smaller, the number of rolling elements supporting the load will be smaller and the load carrying capacity of the bearing will be correspondingly reduced.

In a bearing arrangement comprising two single row angular contact ball bearings or two taper roller bearings back-to-back or face-to-face, each bearing must accommodate the axial forces from the other. When the two bearings are the same, the radial load acts centrally between the bearings and if the bearing arrangement is adjusted to zero clearance, the load distribution where half of the rolling elements are under load will be automatically achieved. In other load cases, particularly where there is an external axial load, it may be necessary to preload the bearings to compensate for the play produced as a result of the elastic deformation of the bearing taking the axial load into account and to achieve a more favourable load distribution in the other bearing, which is unloaded axially.

Preloading also increases the stiffness of the bearing arrangement. When considering stiffness it should be remembered that it is not only influenced by the resilience of the bearings, but also by the elasticity of the shaft and housing, the fits with which the rings are mounted and the elastic deformation of all other components in the force field including the abutments. These all have a considerable impact on the resilience of the total shaft system. The axial and radial resilience of a bearing depend on its internal design, i.e. on the contact conditions (point or line contact), the number and diameter of the rolling elements and the contact angle; the greater the contact angle, the greater the stiffness of the bearing in the axial direction.

Fig. 37

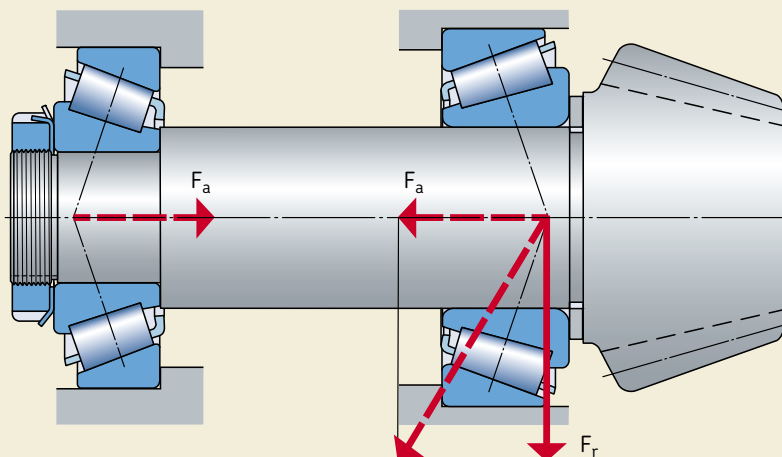

Application of bearings

If, as a first approximation, a linear dependence of the resilience on the load is assumed, i.e. a constant spring ratio, then a comparison shows that the axial displacement in a bearing arrangement under preload is smaller than for a bearing arrangement without preload for the same external axial force K_a (→ **diagram 2**). A pinion bearing arrangement, for example, consists of two taper roller bearings A and B of different size having the spring constants c_A and c_B and is subjected to a preload force F_0 . If the axial force K_a acts on bearing A, bearing B will be unloaded, and the additional load acting on bearing A and the axial displacement δ_a will be smaller than for a bearing without preload. However, if the external axial force exceeds the value

$$K_a = F_0 \left(1 + \frac{c_A}{c_B} \right)$$

then bearing B will be relieved of the axial preload force and the axial displacement under additional load will be the same as it is for a bearing arrangement without preload, i.e. determined solely by the spring constant of bearing A. To prevent complete unloading of bearing B when bearing A is subjected to load K_a , the following preload force will thus be required

$$F_0 = K_a \frac{c_B}{c_A + c_B}$$

The forces and elastic displacements in a preloaded bearing arrangement as well as the effects of a change in preload force are most easily recognized from a preload force/preload path diagram (→ **diagram 3**). This consists of the spring curves of the components that are adjusted against each other to preload and enables the following

- the relationship of the preload force and preload path within the preloaded bearing arrangement
- the relationship between an externally applied axial force K_a and the bearing load for a preloaded bearing arrangement, as well as the elastic deformation produced by the external force.

In the **diagram 3**, all the components subjected to additional loads by the operational forces are represented by the curves that increase from left to right, and all the unloaded components by the curves that increase from right to left. Curves 1, 2 and 3 are for different preload forces ($F_{01}, F_{02} < F_{01}$ and $F_{03} = 0$). The broken lines refer to the bearings themselves whereas the unbroken lines are for the bearing position in total (bearing with associated components).

Using **diagram 3** it is possible to explain the relationships, for example, for a pinion bearing arrangement (→ **fig. 39, page 213**) where bearing A is adjusted against bearing B via the shaft and housing to give preload. The external axial force K_a (axial component of tooth forces) is superimposed on the preload force F_{01} (curve 1) in such a way that bearing A is subjected to additional load while bearing B is unloaded. The load at bearing position A is designated F_{aA} , that at bearing position B, F_{aB} .

Under the influence of the force K_a , the pinion shaft is axially displaced by the amount δ_{a1} . The smaller preload force F_{02} (curve 2) has been chosen so that bearing B is just unloaded by the axial force K_a , i.e. $F_{aB} = 0$ and $F_{aA} = K_a$. The pinion shaft is displaced in this case by the amount $\delta_{a2} > \delta_{a1}$. When the arrangement is not preloaded (curve 3) the axial displacement of the pinion shaft is at its greatest ($\delta_{a3} > \delta_{a2}$).

Diagram 2

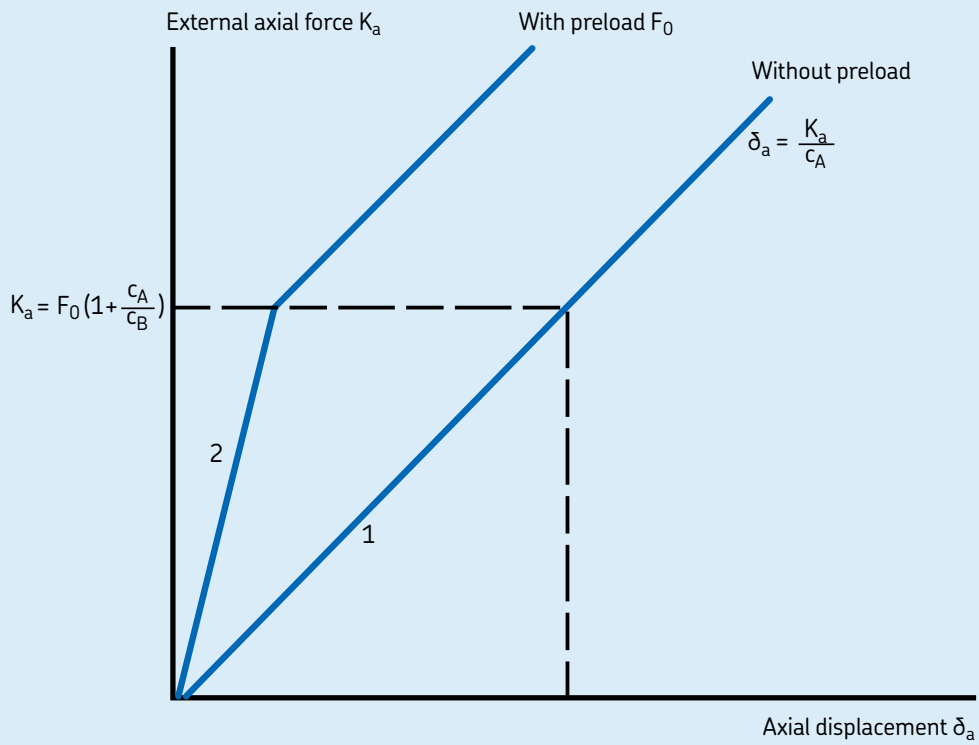
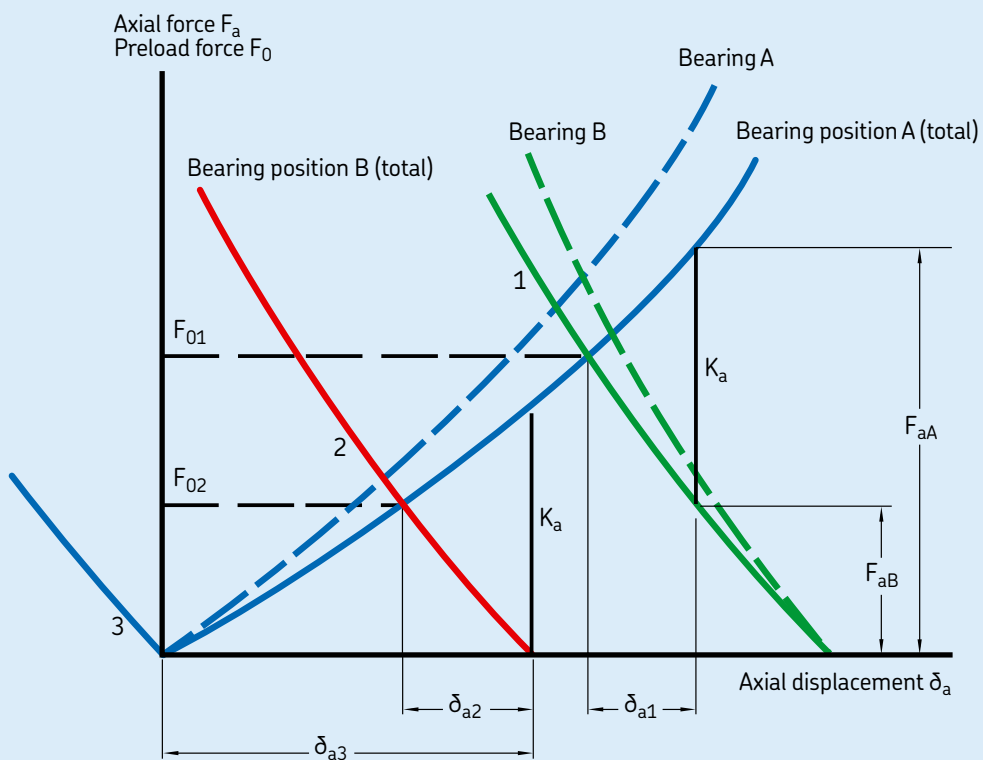

Diagram 3



Application of bearings

Adjustment procedures

Adjustment means setting the bearing internal clearance (→ section “Mounting”, starting on **page 261**) or setting the preload of a bearing arrangement.

The radial preload usually used for cylindrical roller bearings, double row angular contact ball bearings and sometimes for deep groove ball bearings, for example, is achieved by using a sufficient degree of interference for one or both of the bearing rings to reduce the initial internal clearance of the bearing to zero so that in operation there will be a negative clearance, i.e. preload.

Bearings with a tapered bore are particularly suitable for radial preloading since, by driving the bearing up on to its tapered seating, the preload can be applied to within narrow limits.

Axial preload in single row angular contact ball bearings, taper roller bearings and also deep groove ball bearings is produced by displacing one bearing ring axially in relation to the other by an amount corresponding to the desired preload force. There are two main groups of adjustment methods that differ in the principle on which they are based: individual adjustment and collective adjustment.

Individual adjustment

With individual adjustment, each bearing arrangement is adjusted separately using nuts, shims, spacer sleeves, deformable sleeves etc. Measuring and inspection procedures provide that the established nominal preload force is obtained with the least possible deviation. There are different methods depending on the quantity of bearings to be measured

- adjustment using preload path
- adjustment using friction torque
- adjustment using direct force measurement.

Individual adjustment has the advantage that individual components can be produced to Normal tolerances and the desired preload can be achieved with a reasonably high degree of accuracy.

Adjustment using preload path

This method of adjustment is frequently used when the components of a bearing arrangement are pre-assembled. The preload is achieved, for example, for a pinion bearing arrangement by

- fitting intermediate rings between the outer and inner rings of the two bearings (→ **fig. 38**)
- inserting shims between a housing shoulder and a bearing outer ring or between the casing and the housing (→ **fig. 39**), the housing in this case is the flanged angled insert
- fitting a spacer ring between a shaft shoulder and one of the bearing inner rings (→ **fig. 40**) or between the inner rings of the two bearings.

Fig. 38

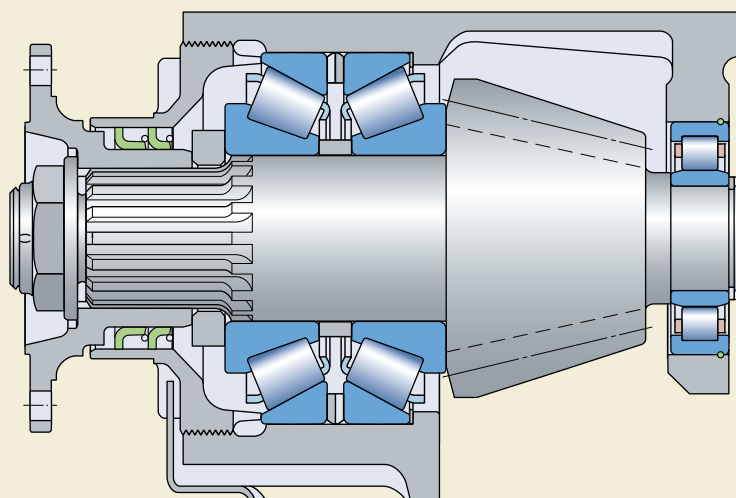

Fig. 39

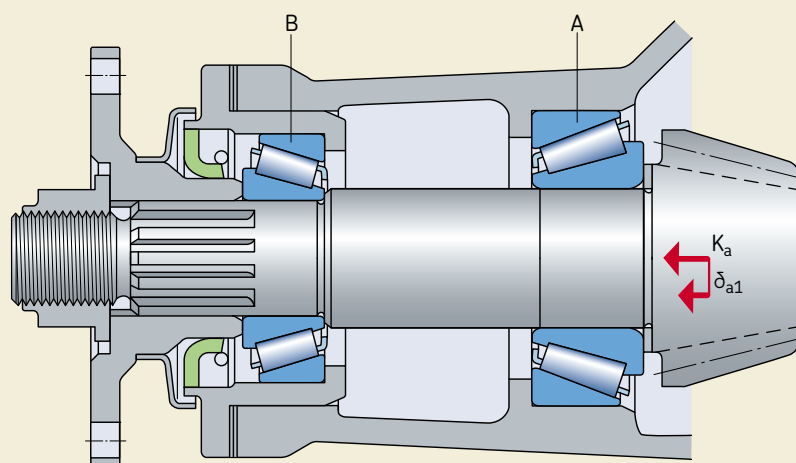
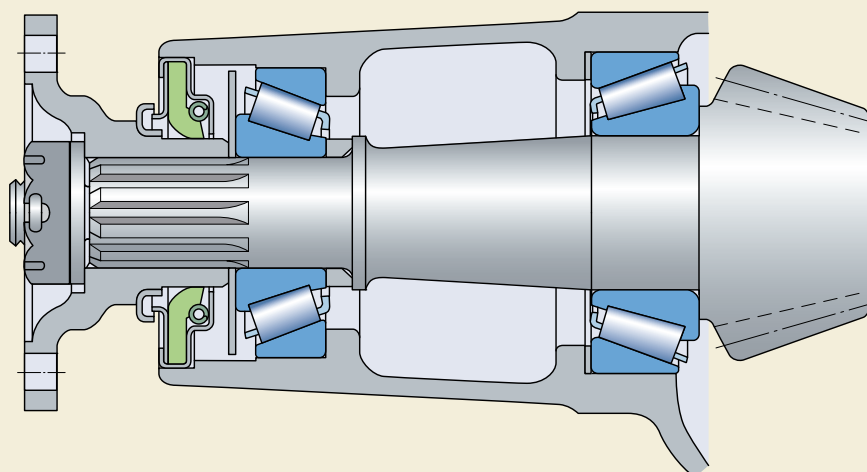

Fig. 40



Application of bearings

The width of the shims, intermediate rings or spacer rings is determined by

- the distance between the shaft and housing shoulders
- the total width of both bearings
- the preload path (axial displacement) corresponding to the desired preload force
- a correction factor for the preload path to account for thermal expansion in operation
- the manufacturing tolerances of all related components, established by measuring the actual dimensions before mounting
- a correction factor to account for a certain loss of preload force after a certain period of operation.

This method of adjustment is based on the relationship between the preload force and the elastic deformations within the preloaded system. The requisite preload can be determined from a preload force/preload path diagram (→ **diagram 4**).

Diagram 4

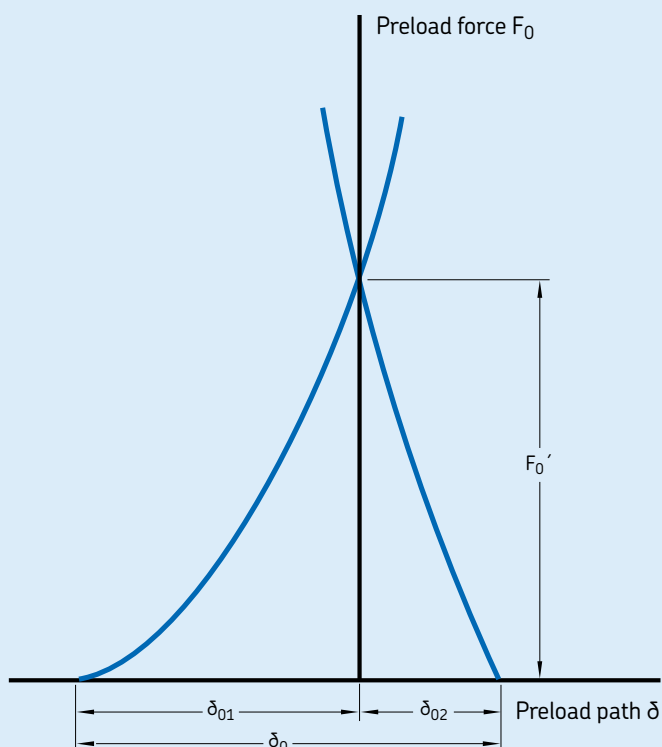

F_0' preload force on the pinion shaft (bearing arrangement)

δ_{01} preload path for the pinion head bearing and surrounding components

δ_{02} preload path for the bearing at the flange side and surrounding components

δ_0 total preload path for pinion bearing arrangement

Adjustment using the frictional moment

This method is popular in series production because of the short time required and because considerable automation is possible. Since there is a definite relationship between bearing preload and the frictional moment in the bearing, it is possible to stop adjustment when a frictional moment corresponding to the desired preload has been reached if the frictional moment is continuously monitored. However, it should be remembered that the frictional moment can vary from bearing to bearing, and that it also depends on the preservative used, or on the lubrication conditions and the speed.

Adjustment using direct force measurement

As the purpose of bearing adjustment is to produce a given preload in the bearings, it would seem sensible to use a method either to produce the force directly, or to measure the force directly. However, in practice the indirect methods of adjustment by preload path or friction torque are preferred as they are simple and can be achieved easily and more cost efficiently.

Collective adjustment

With this method of adjustment, which may also be termed “random statistical adjustment”, the bearings, shaft and housing, spacer rings or sleeves etc. are produced in normal quantities and randomly assembled, the components being fully interchangeable. Where taper roller bearings are concerned, this interchangeability also extends to the outer rings and inner ring assemblies. In order not to have to resort to the uneconomic production of very accurate bearings and associated components, it is assumed that the limiting values of the tolerances – statistically – seldom occur together. If, however, the preload force is to be obtained with as little scatter as possible, manufacturing tolerances must be reduced. The advantage of collective adjustment is that no inspection is required and no extra equipment needed when mounting the bearings.

Application of bearings

Preloading by springs

By preloading bearings in small electric motors and similar applications it is possible to reduce operating noise. The bearing arrangement in this case comprises a single row deep groove ball bearing at each end of the shaft. The simplest method of applying preload is by a spring or spring “package” (→ **fig. 41**). The spring acts on the outer ring of one of the two bearings; this outer ring must be able to be axially displaced. The preload force remains practically constant even when there is axial displacement of the bearing as a result of thermal expansion. The requisite preload force can be estimated from

$$F = k d$$

where

F = preload force, kN

k = a factor, see following

d = bearing bore diameter, mm

Depending on the design of the electric motor, values of between 0,005 and 0,01 are used for the factor k . If preload is used primarily to protect the bearing from vibration damage when stationary, then greater preload is required and $k = 0,02$ should be used.

Spring loading is also a common method of applying preload to angular contact ball bearings used in high-speed grinding spindles. The method is not suitable, however, for bearing applications where a high degree of stiffness is required, where the direction of load changes, or where undefined shock loads can occur.

Maintaining the correct preload

When selecting the preload force for a bearing arrangement it should be remembered that the stiffness is only marginally increased when the preload exceeds a given optimum value, whereas friction and consequently heat generation increase and there is a sharp decrease in bearing service life as a result of the additional, constantly acting load. **Diagram 5** indicates the relationship between bearing life and preload/clearance. Because of the risk that an excessive preload implies for the operational reliability of a bearing arrangement, and because of the complexity of the calculations normally required to establish the appropriate preload force, it is advisable to consult the SKF application engineering service.

It is also important when adjusting preload in a bearing arrangement, that the established value of the preload force, determined either by

Fig. 41

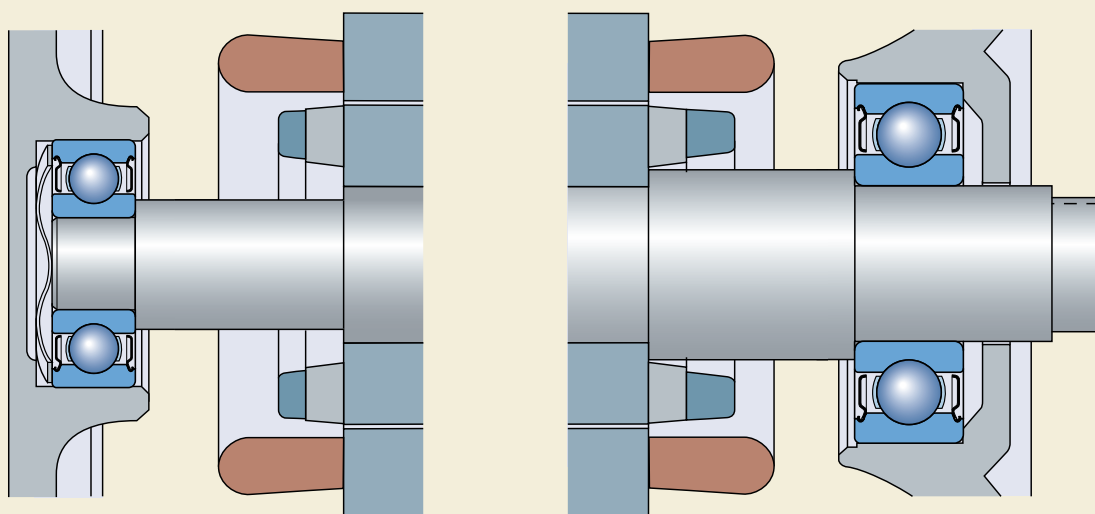

calculation or by experience, is achieved with the least possible scatter. This means, for example, for bearing arrangements with taper roller bearings, that the bearings should be turned several times during adjustment so that the rollers do not skew and so that the roller ends are in correct contact with the guide flange of the inner ring. If this is not the case, the results obtained during inspection or by measurements will be false and the final preload can be much smaller than the requisite value.

Bearings for preloaded bearing arrangements

For certain applications, SKF supplies single bearings or matched bearing sets, which are specifically made to enable simple and reliable adjustment, or which are matched during manufacture so that after mounting, a predetermined value of the preload will be obtained. These include

- taper roller bearings to the CL7C specifications for automotive pinion and differential bearing arrangements (→ section “Single row taper roller bearings”, starting on **page 605**),
- single row angular contact ball bearings for universal matching (→ section “Single row angular contact ball bearings”, starting on **page 409**),
- paired single row taper roller bearings, e.g. for industrial gearboxes (→ section “Paired single row taper roller bearings”, starting on **page 671**), and
- paired single row deep groove ball bearings (→ section “Single row deep groove ball bearings”, starting on **page 289**).

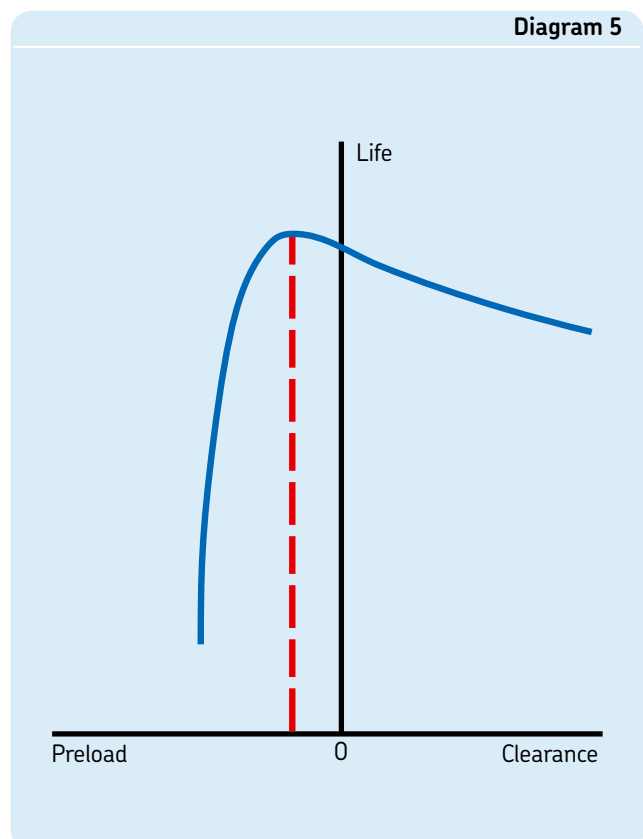

Sealing arrangements

Whatever the bearing arrangement, it consists not only of the bearings but includes associated components. Besides shafts and housings these associated components include the sealing, the performance of which is vital to the cleanliness of the lubricant and the overall service life of the bearing arrangement. For the designer, this means that bearing and sealing arrangement should be viewed as an integrated system and should be treated as such.

Where seals for rolling bearings are concerned, a distinction is made between seals that are integral with the bearing and those that are positioned outside the bearing and are separate from it. Sealed bearings are generally used for arrangements where a sufficiently effective external seal cannot be provided because there is inadequate space or for cost reasons.

Types of seals

The purpose of a seal is to prevent any contaminants from entering into a controlled environment. External seals must be able to prevent media from passing between a stationary and rotating surface, e.g. a housing and shaft. Integral bearing seals must be able to keep contaminants out and lubricant in the bearing cavity.

To be effective, the seal should be sufficiently capable of deformation to be able to compensate for any surface irregularities but also be strong enough to withstand operating pressures. The materials from which the seal is made should also be able to withstand a wide range of operating temperatures, and have appropriate chemical resistance.

There are several seal types; for example, DIN 3750 distinguishes between the following basic types

- seals in contact with stationary surfaces
- seals in contact with sliding surfaces
- non-contact seals
- bellows and membranes.

The seals in contact with stationary surfaces are known as static seals and their effectiveness depends on the radial or axial deformation of their cross section when installed. Gaskets (→ fig. 42) and O-rings (→ fig. 43) are typical examples of static seals.

Fig. 42

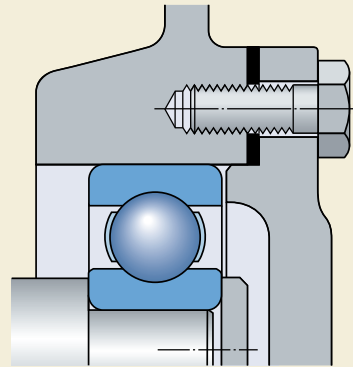

Fig. 43

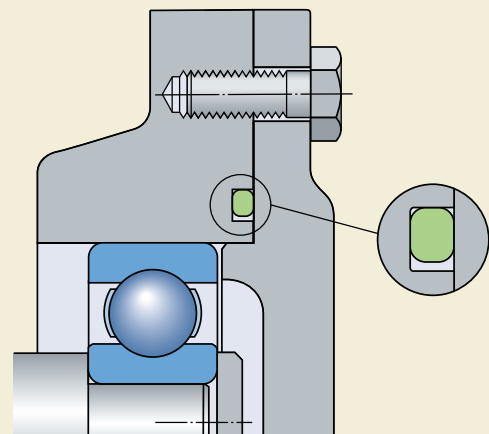
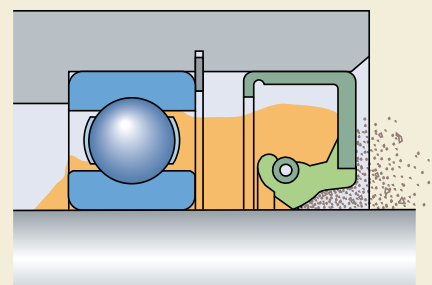

Fig. 44



Seals in contact with sliding surfaces are called dynamic seals and are used to seal passages between machine components that move relative to each other either linearly or in the circumferential direction. These dynamic seals have to retain lubricant, exclude contaminants, separate different media and withstand differential pressures. There are various types of dynamic seals, including packing and piston seal rings, which are used for linear or oscillating movements. However, the most common seal is the radial shaft seal (→ **fig. 44**), which is used in a wide variety of applications in all branches of industry.

Non-contact radial shaft seals function by virtue of the sealing effect of a narrow, relatively long gap, which can be arranged axially, radially or in combination. Non-contact seals, which range from simple gap-type seals to multi-stage labyrinths (→ **fig. 45**) are practically without friction and do not wear.

Bellows and membranes are used to seal components that have limited movement relative to each other.

Because of the importance of dynamic radial seals for the efficient sealing of bearing arrangements, the following information deals almost exclusively with radial seals, their various designs and executions.

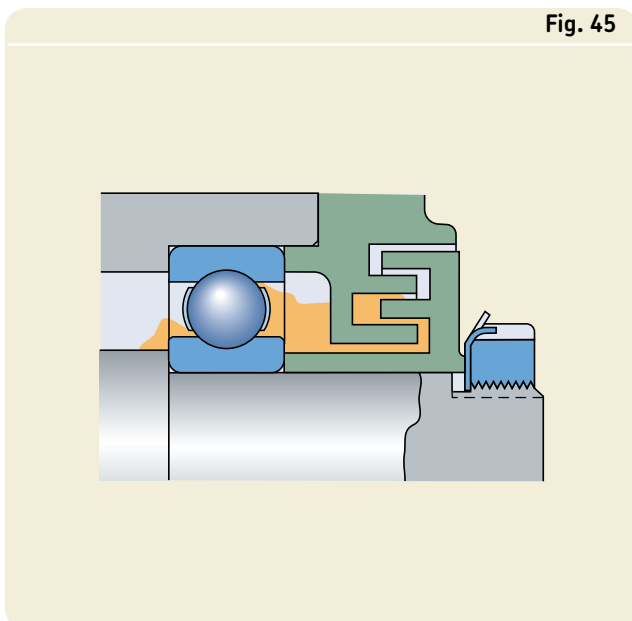

Fig. 45

Selection of seal type

Seals for bearing arrangements should provide a minimum amount of friction and wear while providing maximum protection, even under the most arduous conditions. Because bearing performance and service life are so closely tied to the effectiveness of the seal, the influence of contaminants on bearing life is a key design factor. For more information on the influence of contamination on bearing performance, please refer to the section “Selection of bearing size”, starting on **page 49**.

Many factors have to be considered when selecting the most suitable seal type for a particular bearing arrangement

- the lubricant type: oil or grease
- the peripheral (circumferential) speed at the sealing surface
- the shaft arrangement: horizontal or vertical
- possible shaft misalignment
- available space
- seal friction and the resulting temperature increase
- environmental influences
- justifiable cost.

Selecting the correct seal is of vital importance to the performance of a bearing. It is therefore necessary to accurately specify the sealing requirements and to accurately define the external conditions.

Where full application details are available, reference can be made to the SKF publications

- catalogue “Industrial seals”
- handbook “Sealing arrangement design guide”
- “SKF Interactive Engineering Catalogue” on CD-ROM or online at www.skf.com.

Application of bearings

If little or no experience is available for a given application, SKF, also one of the largest seal manufacturers in the world, can assist in the selection process or make proposals for suitable seals.

Two types of external sealing devices are normally used with rolling bearings: non-contact and contact seals. The type chosen depends on the needs of the application.

Non-contact seals

The effectiveness of an external non-contact seal depends in principle on the sealing action of the narrow gap between the rotating and stationary components. The gap may be arranged radially, axially or in combination (→ **fig. 46**). These seals can be as simple as a gap-type seal or more complex like a labyrinth seal. In either case, because there is no contact, these seals generate virtually no friction and do not wear. They are generally not easily damaged by solid contaminants and are particularly suitable for high speeds and high temperatures. To enhance their sealing efficiency grease can be pressed into the gap(s) formed by the labyrinth.

Contact seals

The effectiveness of a contact seal depends on the seal's ability to exert a minimum pressure on its counterface by a relatively narrow sealing lip or surface. This pressure (→ **fig. 47**) may be produced either by

- the resilience of the seal, resulting from the elastic properties of the seal material (**a**)
- the designed interference between the seal and its counterface (**b**)
- a tangential force exerted by a garter spring incorporated in the seal (**c**).

Contact seals are generally very reliable, particularly when wear is kept to a minimum by producing an appropriate surface finish for the counterface and by lubricating the seal lip/counterface contact area. The friction of the seal on its counterface and the rise in temperature that this generates are a disadvantage and contact seals are therefore only useful for operation up to certain peripheral speeds depending mainly on the seal type and counterface roughness. They are also susceptible to mechanical damage, e.g. as a result of improper mounting, or by solid contaminants. To prevent damage by solid contaminants it is customary to place a non-contact seal in front of a contact seal in order to protect it.

Fig. 46

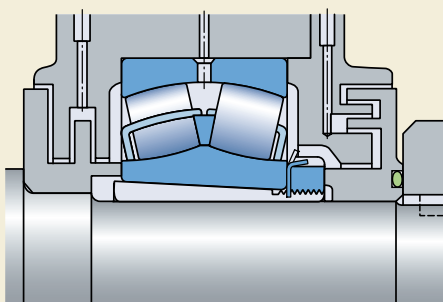
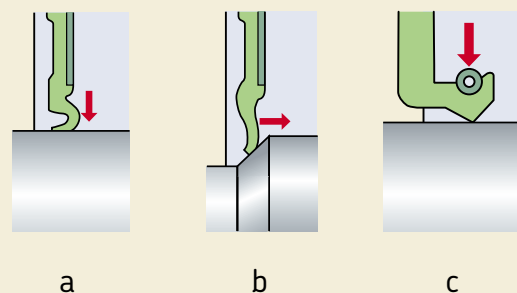

Fig. 47



Integral bearing seals

SKF supplies several bearing types fitted with shields or contact seals on one or both sides. These provide an economic and space-saving solution to many sealing problems. Bearings with shields or seals on both sides are supplied already greased and are generally maintenance-free. Actual seal designs are described in detail in the introductory text to the relevant bearing table sections.

Bearings with shields

Bearings fitted with shields (→ **fig. 48**), are used for arrangements where contamination is not heavy and where there is no danger of water, steam etc. coming into contact with the bearing. Shields are also used in applications where reduced friction is important due to speed or operating temperature considerations.

Shields are made from sheet steel and form

- a long sealing gap with the land of the inner ring shoulder (**a**) or
- an efficient labyrinth seal with a recess in the inner ring shoulder (**b**).

Bearings with contact seals

Bearings with contact seals, referred to simply as seals are preferred for arrangements where contamination is moderate and where the presence of moisture or water spray etc. cannot be ruled out, or where a long service life without maintenance is required.

Fig. 48

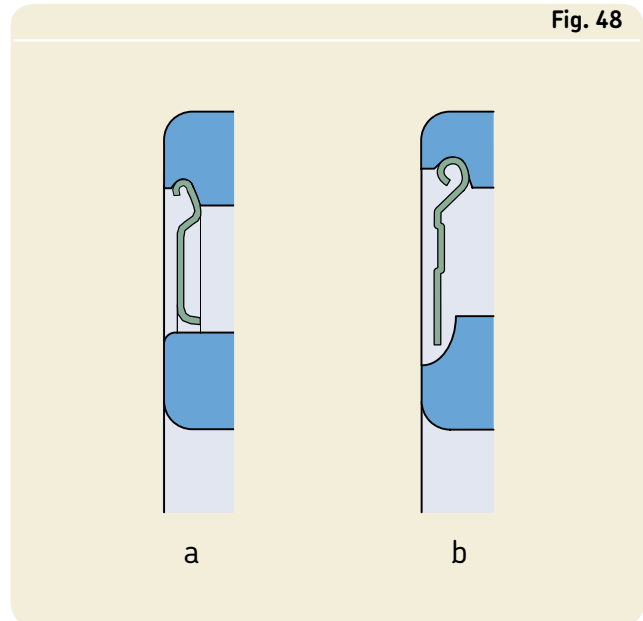

SKF has developed a series of seals (→ **fig. 49**). Depending on the bearing type and/or size the bearings may be equipped with standard seals that seal against

- the inner ring shoulder (**a**) and/or against a recess in the inner ring shoulder (**b, c**) or
- the lead-in at the sides of the inner ring raceway (**d, e**) or the outer ring (**f**).

Fig. 49

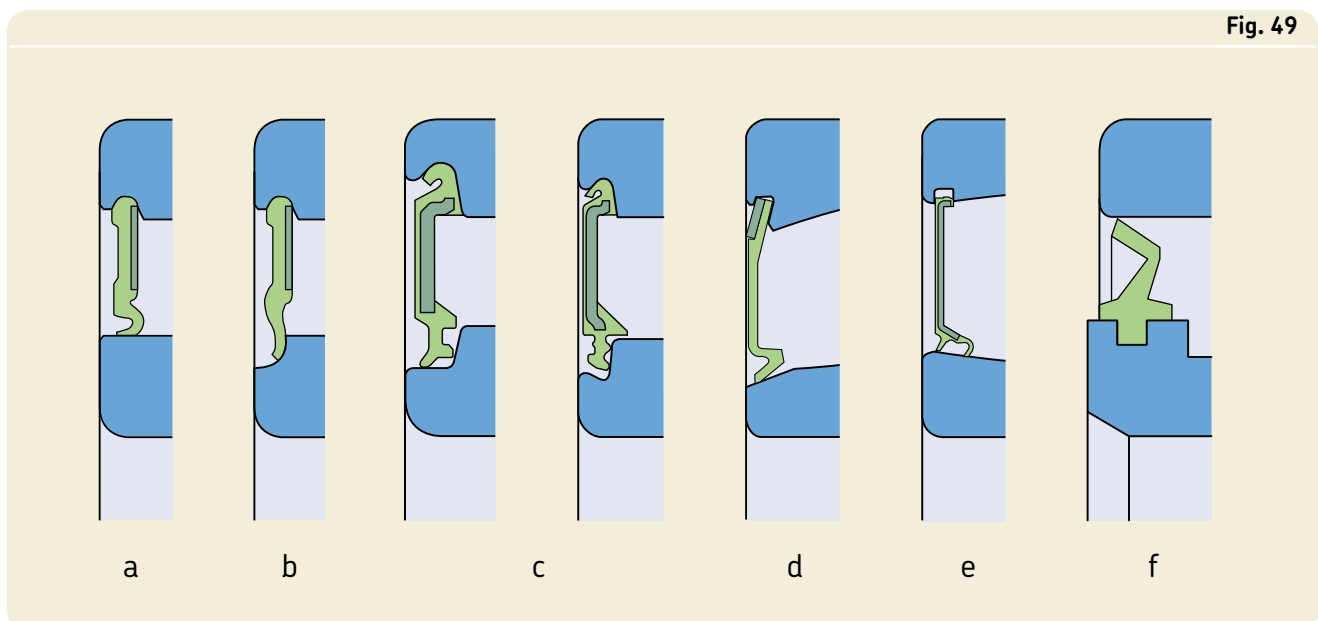

Application of bearings

For deep groove ball bearings SKF has developed two additional seal types (→ **fig. 50**), referred to as

- the low-friction seal (**a, b, c**), which is practically without contact and fulfils high demands on sealing and the low-friction operation of the bearing
- the spring-loaded radial shaft Waveseal® (**d**), which is incorporated on one side and together with the bearing, form the ICOS™ oil sealed bearing unit.

Seals integrated in SKF bearings are generally made of elastomer materials and reinforced by sheet steel. Depending on the series, size and the application requirements, the seals are generally produced from

- acrylonitrile-butadiene rubber (NBR)
- hydrogenated acrylonitrile-butadiene rubber (HNBR)
- fluoro rubber (FKM)
- polyurethane (AU).

The selection of the appropriate seal material depends on the expected operating temperature and the applied lubricant. Concerning the permissible operating temperatures, please refer to the section “Seal materials”, starting on **page 142**.

Fig. 50

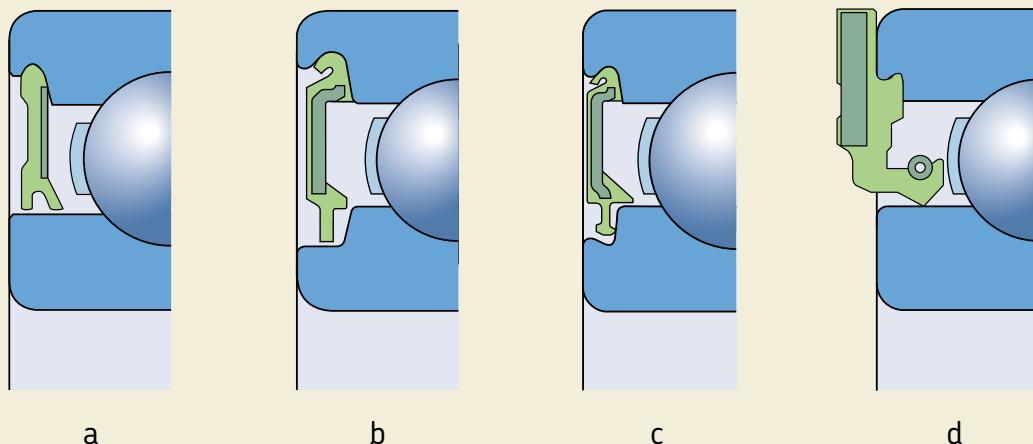

External seals

For bearing arrangements where the efficiency of the seal under the given operating conditions is more important than space considerations or cost, there are several possible seal types to choose from.

The seals offered by SKF are given special attention in the following section. Many ready-to-mount external seals are available commercially. For seals that are not part of the SKF range, the information provided in the following section is to be used as a guideline only. SKF takes no responsibility for the performance of these non-SKF products. Make sure to check with the seal manufacturer before designing any seal into an application.

Non-contact seals

The simplest seal used outside the bearing is the gap-type seal, which creates a small gap between the shaft and housing (\rightarrow **fig. 51**). This type of seal is adequate for grease lubricated applications that operate in dry, dust-free environments. To enhance the efficiency of this seal, one or more concentric grooves can be machined in the housing bore at the shaft exit (\rightarrow **fig. 52**). The grease emerging through the gap fills the grooves and helps to prevent the entry of contaminants.

With oil lubrication and horizontal shafts, helical grooves – right-hand or left-hand depending on the direction of rotation of the shaft – can be provided in the shaft or housing bore (\rightarrow **fig. 53**). These serve to return emerging oil to the bearing position. It is essential here that the direction of shaft rotation does not change.

Fig. 51

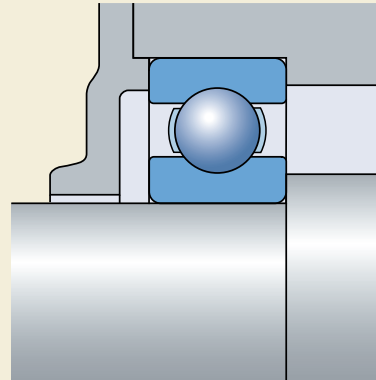

Fig. 52

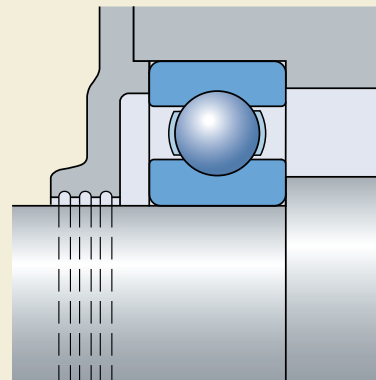

Fig. 53

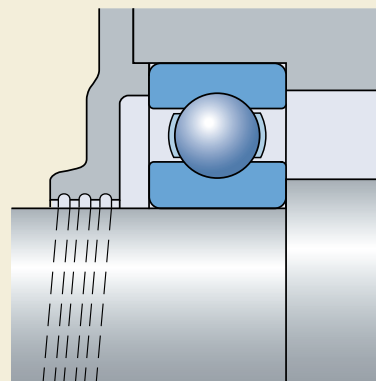

Fig. 54

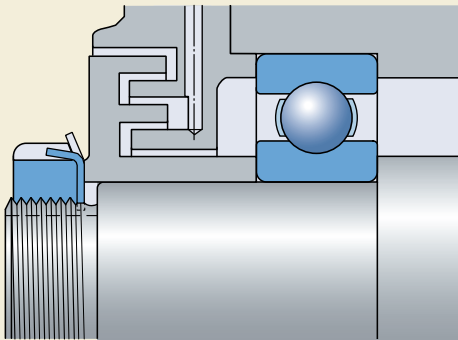

Fig. 55

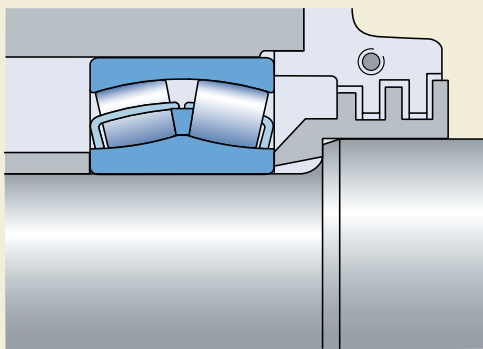

Fig. 56

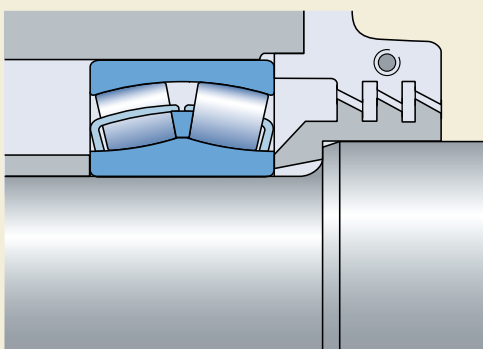
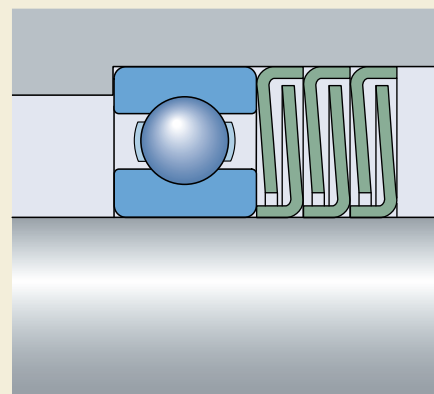

Fig. 57



Single or multi-stage labyrinth seals are considerably more effective than simple gap-type seals, but are more expensive to produce. They are chiefly used with grease lubrication. Their efficiency can be further improved by periodically applying a water-insoluble grease, e.g. a grease with a lithium-calcium thickener, via a duct to the labyrinth passages. The tongues of the labyrinth seal are arranged axially (→ **fig. 54**) or radially (→ **fig. 55**), depending on the housing, split or one-piece, mounting procedures, available space etc. The width of the axial passages of the labyrinth remains unchanged when axial displacement of the shaft occurs in operation and can thus be very narrow. If angular misalignment of the shaft with respect to the housing can occur, labyrinths with inclined passages are used (→ **fig. 56**).

Effective and inexpensive labyrinth seals can be made using commercially available products, e.g. using SKF sealing washers (→ **fig. 57**). Sealing efficiency increases with the number of washer sets used, or can be further enhanced by incorporating flocked washers. Additional information on these sealing washers can be found in the section “Seals” in the “SKF Interactive Engineering Catalogue”, available on CD-ROM or online at www.skf.com.

Rotating discs (→ **fig. 58**) are often fitted to the shaft to improve the sealing action of shields, and flinger rings, grooves or discs are used for the same purpose with oil lubrication. The oil from the flinger is collected in a channel in the housing and returned to the inside of the housing through suitable ducts (→ **fig. 59**).

Contact seals

Radial shaft seals are contact seals that are used, above all, for sealing oil-lubricated bearing arrangements. These ready-to-mount elastomer sealing components normally have a metal reinforcement or casing. The sealing lip is usually a synthetic rubber and is normally pressed against a counterface on the shaft by a garter spring. Depending on the seal material and medium to be retained and/or excluded, radial shaft seals can be used at temperatures between -60 and $+190$ °C.

The contact area between the sealing lip and counterface is of vital importance to sealing efficiency. The surface hardness of the counterface should normally be at least 55 HRC and the hardened depth should be at least 0,3 mm, the surface roughness to ISO 4288:1996 should be within the guidelines of $R_a = 0,2$ to $0,8$ μm . In applications, where speeds are low, lubrication is good and contamination is minimal, a lower hardness can be acceptable. To avoid the pumping action produced by helical grinding marks, plunge grinding is recommended.

If the main purpose of the radial shaft seal is to prevent lubricant from leaving the housing, the seal should be mounted with the lip facing inwards (\rightarrow **fig. 60**). If the main purpose is to exclude contaminants, the lip should face outwards, away from the bearing (\rightarrow **fig. 61**).

Fig. 59

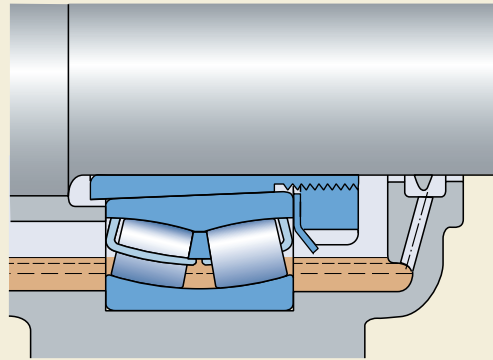

Fig. 60

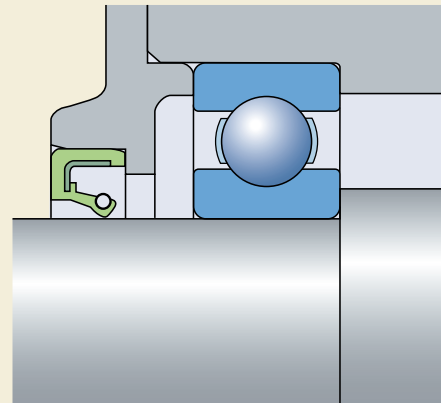

Fig. 61

Fig. 58

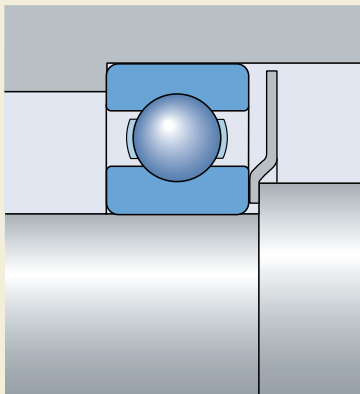

Fig. 62

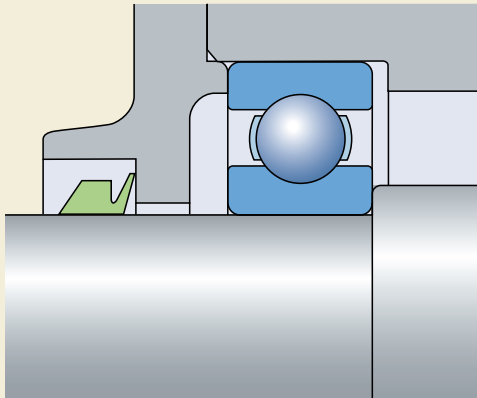

Fig. 63

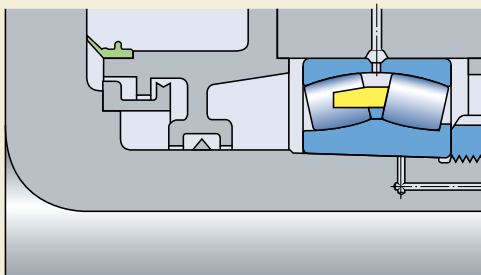
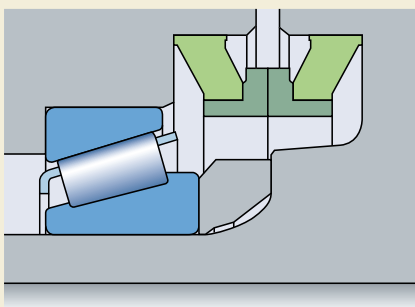

Fig. 64



V-ring seals (→ **fig. 62**) can be used both with oil and with grease lubrication. The elastic rubber ring (body) of the seal firmly grips the shaft and rotates with it, while the sealing lip exerts a light axial pressure on the stationary component, e.g. the housing. Depending on the material, V-rings can be used at operating temperatures between -40 and $+150$ °C. They are simple to install and at low speeds permit relatively large angular misalignments of the shaft. A surface roughness R_a of between 2 and 3 μm is sufficient for the counterface. At peripheral speeds above 8 m/s the V-ring must be axially located on the shaft. At speeds above 12 m/s the ring must be prevented from “lifting” from the shaft by, for example, a sheet metal support ring. When the peripheral speed exceeds 15 m/s the sealing lip will lift from the counterface so that the V-ring becomes a gap-type seal. The good sealing action of the V-ring depends mainly on the fact that the ring body acts as a flinger, repelling dirt and fluids. Therefore, with grease lubrication the seal is generally arranged outside the housing, whereas for oil lubrication it is normally arranged inside the housing with the lip pointing away from the bearing position. Used as a secondary seal, V-rings protect the primary seal from excessive contaminants and moisture.

Axial clamp seals (→ **fig. 63**) are used as secondary seals for large diameter shafts in applications where protection is required for the primary seal. They are clamped in position on a non-rotating component and seal axially against a rotating counterface. For this type of seal, it is sufficient if the counterface is fine turned and has a surface roughness R_a of $2,5$ μm .

Mechanical seals (→ **fig. 64**) are used to seal grease or oil lubricated bearing positions where speeds are relatively low and operating conditions difficult and arduous. They consist of two sliding steel rings with finely finished sealing surfaces and two plastic cup springs (Belleville washers), which position the sliding rings in the housing bore and provide the necessary preload force to the sealing surfaces. There are no special demands on the mating surfaces in the housing bore.

Felt seals (→ **fig. 65**) are generally used with grease lubrication. They are simple and inexpensive and can be used at peripheral speeds of up to 4 m/s and at operating temperatures up to +100 °C. The counterface should be ground to a surface roughness $R_a \leq 3,2 \mu\text{m}$. The efficiency of a felt seal can be much improved by mounting a simple labyrinth seal as a secondary seal. Before being inserted in the housing groove, the felt rings or strips should be soaked in oil at about 80 °C.

Spring washers (→ **fig. 66**) provide simple, inexpensive and space-saving seals for grease lubricated rigid bearings, particularly deep groove ball bearings. The washers are clamped against either the outer ring or the inner ring and exert a resilient pressure axially against the other ring. After a certain running-in period these seals become non-contact seals by forming a very narrow gap-type seal.

More detailed information on seals supplied by SKF can be found in the SKF catalogue “Industrial seals” or in the “SKF Interactive Engineering Catalogue” on CD-ROM or online at www.skf.com. Information on other seals incorporated in SKF products, such as seals for housings, are described in detail in literature dealing with these products.

Fig. 65

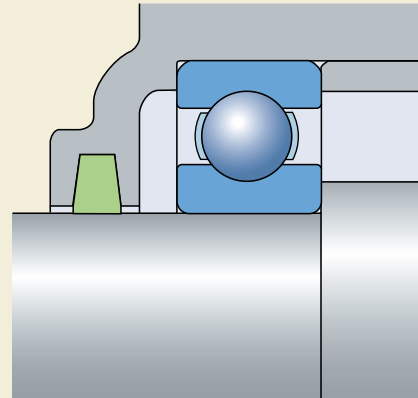
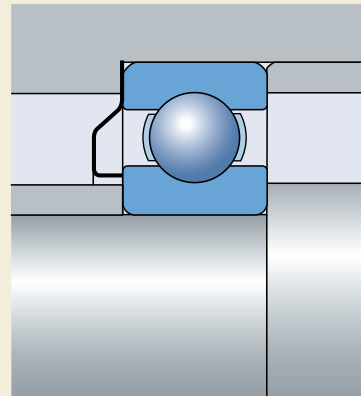
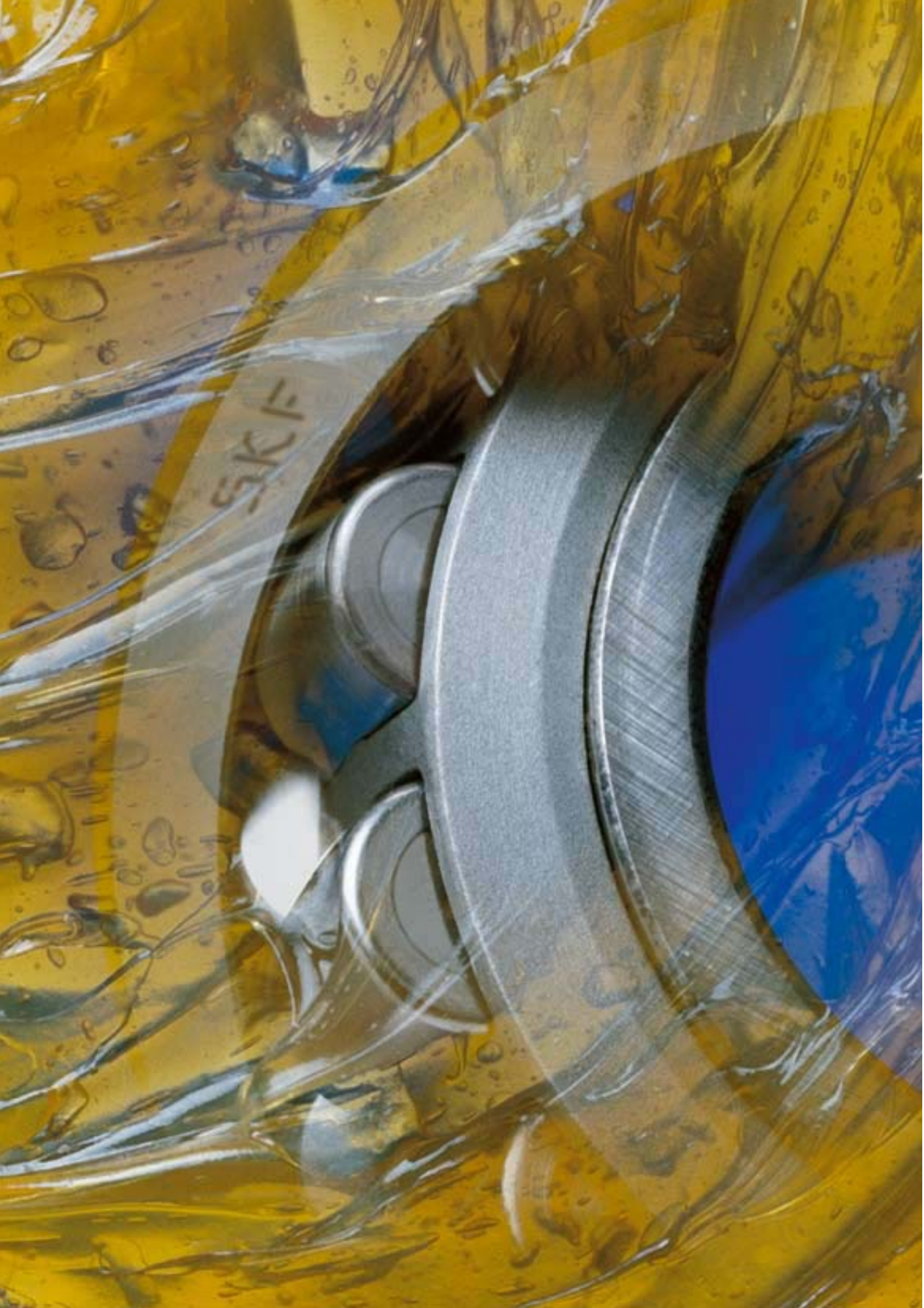

Fig. 66





Lubrication

Grease lubrication	231
Lubricating greases	231
Base oil viscosity.....	231
Consistency.....	232
Temperature range – the SKF traffic light concept.....	232
Protection against corrosion, behaviour in the presence of water.....	234
Load carrying ability: EP and AW additives.....	234
Miscibility.....	236
SKF greases	236
Relubrication	237
Relubrication intervals.....	237
Adjustments of relubrication intervals due to operating conditions and bearing types.....	240
Observations.....	241
Relubrication procedures	242
Replenishment.....	242
Renewing the grease fill.....	244
Continuous relubrication.....	245
Oil lubrication	248
Methods of oil lubrication.....	248
Lubricating oils.....	251
Selection of lubricating oils.....	252
Oil change.....	253

Lubrication

If rolling bearings are to operate reliably they must be adequately lubricated to prevent direct metal-to-metal contact between the rolling elements, raceways and cages. The lubricant also inhibits wear and protects the bearing surfaces against corrosion. The choice of a suitable lubricant and method of lubrication for each individual bearing application is therefore important, as is correct maintenance.

A wide selection of greases and oils is available for the lubrication of rolling bearings and there are also solid lubricants, e.g. for extreme temperature conditions. The actual choice of a lubricant depends primarily on the operating conditions, i.e. the temperature range and speeds as well as the influence of the surroundings.

The most favourable operating temperatures will be obtained when the minimum amount of lubricant needed for reliable bearing lubrication is provided. However, when the lubricant has additional functions, such as sealing or the removal of heat, additional amounts of lubricant may be required.

The lubricant in a bearing arrangement gradually loses its lubricating properties as a result of mechanical work, ageing and the build-up of contamination. It is therefore necessary for grease to be replenished or renewed and for oil to be filtered and changed at regular intervals.

The information and recommendations in this section relate to bearings without integral seals or shields. SKF bearings and bearing units with integral seals and shields on both sides are supplied greased. Information about the greases used by SKF as standard for these products can be found in the text preceding the relevant product tables together with a brief description of the performance data.

The service life of the grease in sealed bearings most often exceeds bearing life so that, with some exceptions, no provision is made for the relubrication of these bearings.

Note

Differences in the lubricating properties of seemingly identical lubricants – particularly grease – produced at different locations can exist. Therefore, SKF cannot accept liability for any lubricant or its performance. The user is therefore advised to specify lubricant properties in detail so as to obtain the most suitable lubricant for the application.

Grease lubrication

Grease can be used to lubricate rolling bearings under normal operating conditions in the majority of applications.

Grease has the advantage over oil that it is more easily retained in the bearing arrangement, particularly where shafts are inclined or vertical, and it also contributes to sealing the arrangement against contaminants, moisture or water.

Excessive amounts of grease will cause the operating temperature within the bearing to rise rapidly, particularly when running at high speeds. As a general rule, when starting up only the bearing should be completely filled, while the free space in the housing should be partly filled with grease. Before operating at full speed, the excess grease in the bearing must be enabled to settle or escape during a running-in period. At the end of the running-in period the operating temperature will drop considerably, indicating that the grease has been distributed in the bearing arrangement.

However, where bearings are to operate at very low speeds and good protection against contamination and corrosion is required, it is advisable to fill the housing completely with grease.

Lubricating greases

Lubricating greases consist of a mineral or synthetic oil combined with a thickener. The thickeners are usually metallic soaps. However, other thickeners, e.g. polyurea can be used for superior performance in certain areas, i.e. high temperature applications. Additives can also be included to enhance certain properties of the grease. The consistency of the grease depends largely on the type and concentration of the thickener used and on the operating temperature of the application. When selecting a grease, the consistency, operating temperature range, viscosity of the base oil, rust inhibiting properties and the load carrying ability are the most important factors to be considered. Detailed information on these properties follows.

Base oil viscosity

The importance of the oil viscosity for the formation of an oil film to separate the bearing surfaces and thus for the life of the bearing is dealt with in the section “Lubrication conditions – the viscosity ratio κ ” on **page 59**; the information applies equally to the base oil viscosity of greases.

The base oil viscosity of the greases normally used for rolling bearings lies between 15 and 500 mm²/s at 40 °C. Greases based on oils having higher viscosities than 1 000 mm²/s at 40 °C bleed oil so slowly that the bearing will not be adequately lubricated. Therefore, if a calculated viscosity well above 1 000 mm²/s at 40 °C is required because of low speeds, it is better to use a grease with a maximum viscosity of 1 000 mm²/s and good oil bleeding properties or to apply oil lubrication.

Lubrication

The base oil viscosity also governs the maximum recommended speed at which a given grease can be used for bearing lubrication. The permissible rotational speed for grease is also influenced by the shear strength of the grease, which is determined by the thickener. To indicate the speed capability, grease manufacturers often quote a “speed factor”

$$A = n d_m$$

where

A = speed factor, mm/min

n = rotational speed, r/min

d_m = bearing mean diameter
= 0,5 (d + D), mm

For applications operating at very high speeds, e.g. at $A > 700\,000$ for ball bearings, the most suitable greases are those incorporating base oils of low viscosity.

Consistency

Greases are divided into various consistency classes according to the National Lubricating Grease Institute (NLGI) scale. The consistency of grease used for bearing lubrication should not change drastically when operated within its specified temperature range after mechanical working. Greases that soften at elevated temperatures may leak from the bearing arrangement. Those that stiffen at low temperatures may restrict rotation of the bearing or have insufficient oil bleeding.

Metallic soap thickened greases, with a consistency of 1, 2 or 3 are used for rolling bearings. The most common greases have a consistency of 2. Lower consistency greases are preferred for low temperature applications, or for improved pumpability. Consistency 3 greases are recommended for bearing arrangements with a vertical shaft, where a baffle plate is arranged beneath the bearing to prevent the grease from leaving the bearing.

In applications subjected to vibration, the grease is heavily worked as it is continuously thrown back into the bearing by vibration. Higher consistency greases may help here, but stiffness alone does not necessarily provide adequate lubrication. Therefore mechanically stable greases should be used instead.

Greases thickened with polyurea can soften or harden depending on the shear rate in the application. In applications with vertical shafts there is a danger that a polyurea grease will leak under certain conditions.

Temperature range – the SKF traffic light concept

The temperature range over which a grease can be used depends largely on the type of base oil and thickener used as well as the additives. The relevant temperatures are schematically illustrated in **diagram 1** in the form of a “double traffic light”.

The extreme temperature limits, i.e. low temperature limit and the high temperature limit, are well defined.

- The low temperature limit (LTL), i.e. the lowest temperature at which the grease will enable the bearing to be started up without difficulty, is largely determined by the type of base oil and its viscosity.
- The high temperature limit (HTL) is determined by the type of thickener and for soap base greases is given by the dropping point. The dropping point indicates the temperature at which the grease loses its consistency and becomes a fluid.

It is evident that operation below the low temperature limit and above the high temperature limit is not advised as shown in **diagram 1** by the red zones. Although grease suppliers indicate the specific values for the low and high temperature limits in their product information, the really important temperatures for reliable operation are given by the SKF values for

- the low temperature performance limit (LTPL) and
- the high temperature performance limit (HTPL).

It is within these two limits, the green zone in **diagram 1**, where the grease will function reliably and grease life can be determined accurately. Since the definition of the high temperature performance limit is not standardized internationally, care must be taken when interpreting suppliers' data.

At temperatures above the high temperature performance limit (HTPL), grease will age and oxidize with increasing rapidity and the by-products of the oxidation will have a detrimental effect on lubrication. Therefore, temperatures in the amber zone, between the high temperature performance limit and the high temperature limit (HTL) should occur only for very short periods.

An amber zone also exists for low temperatures. With decreasing temperature, the tendency of grease to bleed decreases and the stiffness (consistency) of the grease increases. This will ultimately lead to an insufficient supply of lubricant to the contact surfaces of the rolling elements and raceways. In **diagram 1**, this temperature limit is indicated by the low temperature performance limit (LTPL). Values for the low temperature performance limit are different for roller and ball bearings. Since ball bearings are easier to lubricate than roller bearings, the low temperature performance limit is less important for ball bearings. For roller bearings, however, serious damage will result when the bearings are operated continuously below this limit. Short periods in this zone e.g. during a cold start, are not harmful since the heat caused by friction will bring the bearing temperature into the green zone.

Diagram 1

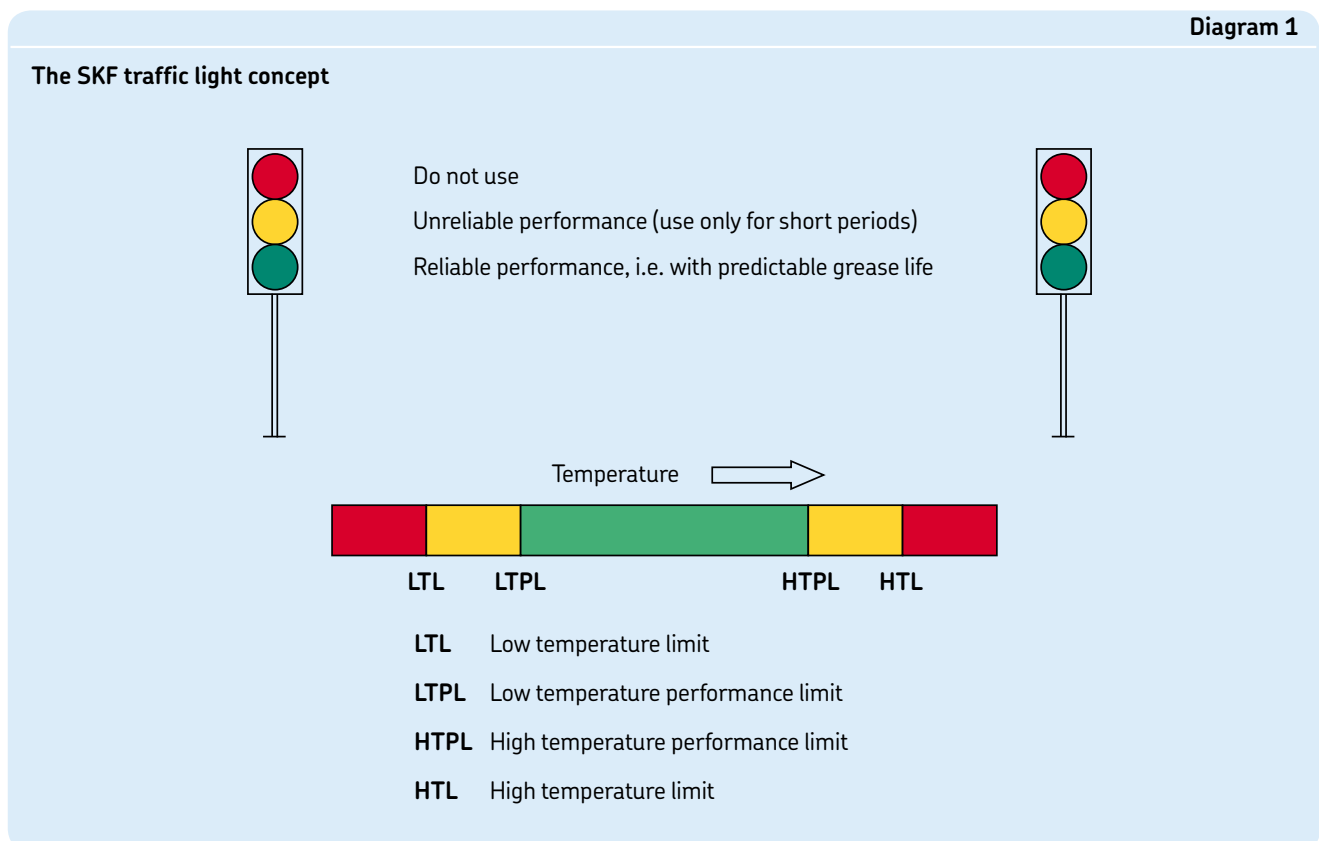

Lubrication

Note

The SKF traffic light concept is applicable for any grease; however, the temperature zones differ from grease to grease and can only be determined by functional bearing testing. The traffic light limits for

- grease types normally used for rolling bearings are shown in **diagram 2** and for
- SKF greases are shown in **diagram 3**.

The temperature zones shown in these diagrams are based on extensive tests conducted in SKF laboratories and may differ from those quoted by lubricant manufacturers. The zones shown in **diagram 2** are valid for commonly available NLGI 2 greases without EP additives. The temperatures in the diagrams relate to the observed self-induced bearing temperature (usually measured on the non-rotating ring). Since the data for each grease type is a summary of many greases of more or less similar composition, the transitions for each group are not sharp but fall within a small range.

Protection against corrosion, behaviour in the presence of water

Grease should protect the bearing against corrosion and should not be washed out of the bearing arrangement in cases of water penetration. The thickener type solely determines the resistance to water: lithium complex, calcium complex and polyurea greases offer usually very good resistance. The type of rust inhibitor additive mainly determines the rust inhibiting properties of greases.

At very low speeds, a full grease pack is beneficial for corrosion protection and for the prevention of water ingress.

Load carrying ability: EP and AW additives

Bearing life is shortened if the lubricant film thickness is not sufficient to prevent metal-to-metal contact of the asperities on the contact surfaces. One option to overcome this is to use so-called EP (Extreme Pressure) additives. High temperatures induced by local asperity contact, activate these additives promoting mild wear at the points of contact. The result is a smoother surface, lower contact stresses and an increase in service life.

Diagram 2

The SKF traffic light concept – standard greases

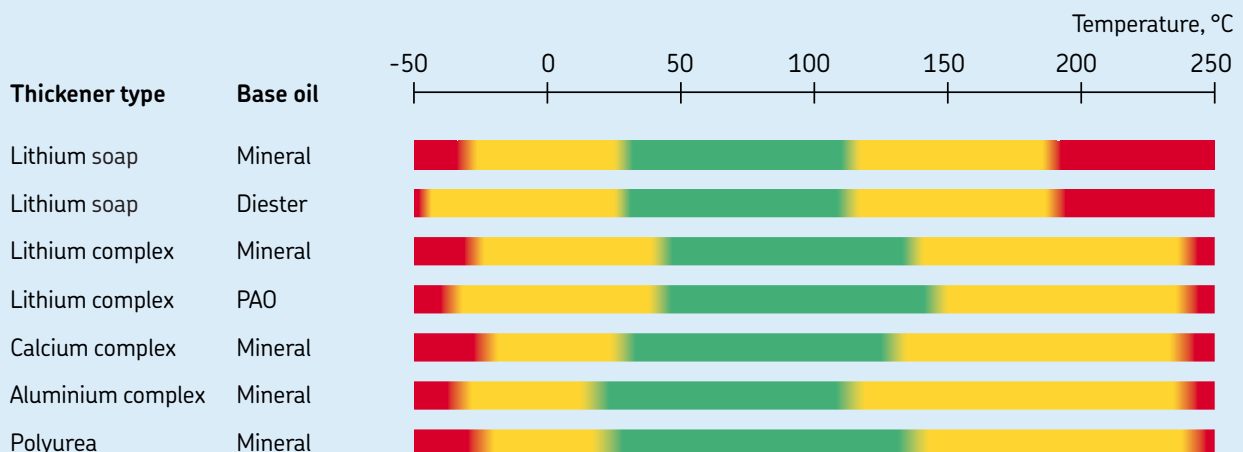

Many modern EP additives are of the sulphur/phosphorus type. Unfortunately these additives may have a negative effect on the strength of the bearing steel matrix. If such additives are used then the chemical activity may not be restricted to the asperity contacts. If the operating temperature and contact stresses are too high, the additives may become chemically reactive even without asperity contact. This can promote corrosion/diffusion mechanisms in the contacts and may lead to accelerated bearing failure, usually initiated by micro pitting. Therefore, SKF recommends the use of less reactive EP additives for operating temperatures above 80 °C. Lubricants with EP additives should not be used for bearings operating at temperatures higher than 100 °C. For very low speeds, solid lubricant additives such as graphite and molybdenum disulphide (MoS₂) are sometimes included in the additive package to enhance the EP effect. These additives should have a high purity level and a very small particle size; other-

wise dents due to overrolling of the particles might reduce bearing fatigue life.

AW (Anti-Wear) additives have a function similar to that of EP additives, i.e. to prevent severe metal-to-metal contact. Therefore EP and AW additives are very often not differentiated between. However, the way they work is different. The main difference is that an AW additive builds a protective layer that adheres to the surface. The asperities are then sliding over each other without metallic contact. The roughness is therefore not reduced by mild wear as in the case of EP additives. Here too special care has to be taken; AW additives may contain elements that, in the same way as the EP additives, can migrate into the bearing steel and weaken the structure.

Certain thickeners (e.g. calcium sulphonate complex) also provide an EP/AW effect without chemical activity and the resulting effect on bearing fatigue life. Therefore, the operating temperature limits for EP additives do not apply for these greases.

Diagram 3

The SKF traffic light concept – SKF greases



For operating temperatures above 150 °C, SKF LGET 2 is recommended

Lubrication

If the lubricant film thickness is sufficient, SKF does not generally recommend the use of EP and AW additives. However there are circumstances where EP/AW additives may be useful. If excessive sliding between the rollers and raceways is expected they may be beneficial. Contact the SKF application engineering service for further information.

Miscibility

If it becomes necessary to change from one grease to another, the miscibility or the ability to mix greases without adverse effects should be considered. If incompatible greases are mixed, the resulting consistency can change dramatically so that bearing damage e.g. due to severe leakage, could result.

Greases having the same thickener and similar base oils can generally be mixed without any detrimental consequences, e.g. a lithium thickener/mineral oil grease can generally be mixed with another lithium thickener/mineral oil grease. Also, some greases with different thickeners e.g. calcium complex and lithium complex greases, are miscible with each other.

In bearing arrangements where a low grease consistency might lead to grease escaping from the arrangement, the next relubrication should involve purging all the old grease from the arrangement and the lubrication ducts, rather than replenishing it (→ section “Relubrication”, starting on **page 237**).

The preservative with which SKF bearings are treated is compatible with the majority of rolling bearing greases with the possible exception of polyurea greases (→ section “Preparations for mounting and dismounting” on **page 258**).

Note that synthetic fluorinated oil based greases using a PTFE thickener, e.g. SKF LGET 2 grease, are not compatible with standard preservatives and the preservatives must be removed before applying grease. Contact the SKF application engineering service for further information.

SKF greases

The SKF range of lubricating greases for rolling bearings comprises many types of grease and covers virtually all application requirements. These greases have been developed based on the latest information about rolling bearing lubrication and have been thoroughly tested both in the laboratory and in the field. Their quality is continuously monitored by SKF.

The most important technical specifications on SKF greases are provided in **table 2** on **pages 246** and **247**, together with a quick selection guide. The temperature ranges where the SKF greases can be used are schematically illustrated in **diagram 3, page 235**, according to the SKF traffic light concept.

Further information on SKF greases can be found in the catalogue “SKF Maintenance and Lubrication Products” or online at www.mapro.skf.com.

For a more detailed selection of the appropriate grease for a specific bearing type and application, use the Internet based SKF grease selection program LubeSelect. This program can be found online at www.apitudexchange.com.

Relubrication

Rolling bearings have to be relubricated if the service life of the grease is shorter than the expected service life of the bearing. Relubrication should always be undertaken at a time when the condition of the existing lubricant is still satisfactory.

The time at which relubrication should be undertaken depends on many related factors. These include bearing type and size, speed, operating temperature, grease type, space around the bearing and the bearing environment. It is only possible to base recommendations on statistical rules; the SKF relubrication intervals are defined as the time period, at the end of which 99 % of the bearings are still reliably lubricated. This represents the L_1 grease life.

SKF recommends using experience based on data from actual applications and tests, together with the estimated relubrication intervals provided hereafter.

Relubrication intervals

The relubrication intervals t_f for bearings with rotating inner ring on horizontal shafts under normal and clean conditions can be obtained from **diagram 4** as a function of

- the speed factor A multiplied by the relevant bearing factor b_f where
 - $A = n d_m$
 - n = rotational speed, r/min
 - d_m = bearing mean diameter
= $0,5 (d + D)$, mm
 - b_f = bearing factor depending on bearing type and load conditions
(→ **table 1, page 239**)
- the load ratio C/P

The relubrication interval t_f is an estimated value, valid for an operating temperature of 70 °C, using good quality lithium thickener/mineral oil greases. When bearing operating conditions differ, adjust the relubrication intervals obtained from **diagram 4** according to the information given under “Adjustments of relubrication intervals due to operating conditions and bearing types”, starting on **page 240**.

If the speed factor A exceeds a value of 70 % of the recommended limit according to **table 1**, or if ambient temperatures are high, then the

use of the calculations presented in the section “Speeds and vibration”, starting on **page 107**, is recommended to check the operating temperature and the proper lubrication method.

When using high performance greases, a longer relubrication interval and grease life may be possible. Contact the SKF application engineering service for additional information.

Relubrication intervals at operating temperatures of 70 °C

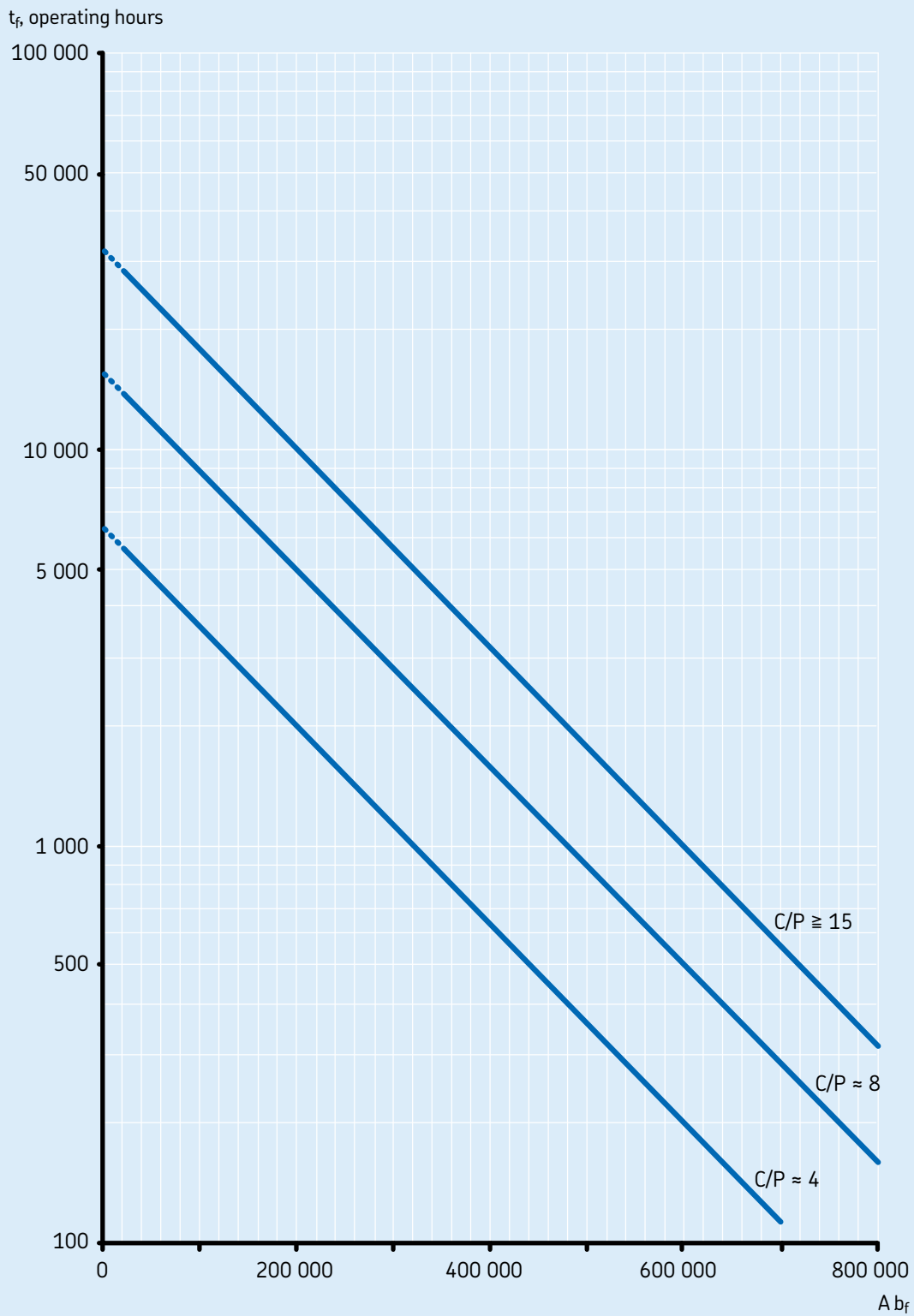

Table 1

Bearing factors and recommended limits for speed factor A				
Bearing type ¹⁾	Bearing factor b_f	Recommended limits for speed factor A for load ratio		
		$C/P \geq 15$	$C/P \approx 8$	$C/P \approx 4$
–	–	mm/min		
Deep groove ball bearings	1	500 000	400 000	300 000
Angular contact ball bearings	1	500 000	400 000	300 000
Self-aligning ball bearings	1	500 000	400 000	300 000
Cylindrical roller bearings				
– non-locating bearing	1,5	450 000	300 000	150 000
– locating bearing, without external axial loads or with light but alternating axial loads	2	300 000	200 000	100 000
– locating bearing, with constantly acting light axial load	4	200 000	120 000	60 000
– without cage, full complement ²⁾	4	NA ³⁾	NA ³⁾	20 000
Taper roller bearings	2	350 000	300 000	200 000
Spherical roller bearings				
– when load ratio $F_a/F_r < e$ and $d_m \leq 800$ mm series 213, 222, 238, 239	2	350 000	200 000	100 000
series 223, 230, 231, 232, 240, 248, 249	2	250 000	150 000	80 000
series 241	2	150 000	80 000 ⁴⁾	50 000 ⁴⁾
– when load ratio $F_a/F_r < e$ and $d_m > 800$ mm series 238, 239	2	230 000	130 000	65 000
series 230, 231, 232, 240, 248, 249	2	170 000	100 000	50 000
series 241	2	100 000	50 000 ⁴⁾	30 000 ⁴⁾
– when load ratio $F_a/F_r > e$ all series	6	150 000	50 000 ⁴⁾	30 000 ⁴⁾
CARB toroidal roller bearings				
– with cage	2	350 000	200 000	100 000
– without cage, full complement ²⁾	4	NA ³⁾	NA ³⁾	20 000
Thrust ball bearings	2	200 000	150 000	100 000
Cylindrical roller thrust bearings	10	100 000	60 000	30 000
Spherical roller thrust bearings				
– rotating shaft washer	4	200 000	170 000	150 000

¹⁾ The bearing factors and recommended practical speed factor “A” limits apply to bearings with standard internal geometry and standard cage execution. For alternative internal bearing design and special cage execution, please contact the SKF application engineering service

²⁾ The t_f value obtained from **diagram 4** needs to be divided by a factor of 10

³⁾ Not applicable, for these C/P values a caged bearing is recommended instead

⁴⁾ For higher speeds oil lubrication is recommended

Adjustments of relubrication intervals due to operating conditions and bearing types

Operating temperature

To account for the accelerated ageing of grease with increasing temperature, it is recommended halving the intervals obtained from the **diagram 4** for every 15 °C increase in operating temperature above 70 °C, remembering that the high temperature performance limit for the grease (→ **diagram 1**, HTPL, on **page 233**) should not be exceeded.

The relubrication interval t_f may be extended at temperatures below 70 °C if the temperature is not close to the lower temperature performance limit (→ **diagram 1**, LTPL, on **page 233**). A total extension of the relubrication interval t_f by more than a factor of two never is recommended. In case of full complement bearings and thrust roller bearings, t_f values obtained from **diagram 4** should not be extended.

Moreover, it is not advisable to use relubrication intervals in excess of 30 000 hours.

For many applications, there is a practical grease lubrication limit, when the bearing ring with the highest temperature exceeds an operating temperature of 100 °C. Above this temperature special greases should be used. In addition, the temperature stability of the bearing and premature seal failure should be taken into consideration.

For high temperature applications please consult the SKF application engineering service.

Vertical shaft

For bearings on vertical shafts, the intervals obtained from **diagram 4** should be halved. The use of a good sealing or retaining shield is a prerequisite to prevent grease leaking from the bearing arrangement.

Vibration

Moderate vibration will not have a negative effect on grease life, but high vibration and shock levels, such as those in vibrating screen applications, will cause the grease to churn. In these cases the relubrication interval should be reduced. If the grease becomes too soft, grease with a better mechanical stability, e.g. SKF grease LGHB 2 or grease with higher stiffness up to NLGI 3 should be used.

Outer ring rotation

In applications where the outer ring rotates, the speed factor A is calculated differently: in this case use the bearing outside diameter D instead of d_m . The use of a good sealing mechanism is a prerequisite in order to avoid grease loss.

Under conditions of high outer ring speeds (i.e. > 40 % of the reference speed listed in the product tables), greases with a reduced bleeding tendency should be selected.

For spherical roller thrust bearings with a rotating housing washer oil lubrication is recommended.

Contamination

In case of ingress of contamination, more frequent relubrication than indicated by the relubrication interval will reduce the negative effects of foreign particles on the grease while reducing the damaging effects caused by overrolling the particles. Fluid contaminants (water, process fluids) also call for a reduced interval. In case of severe contamination, continuous relubrication should be considered.

Very low speeds

Bearings that operate at very low speeds under light loads call for a grease with low consistency while bearings that operate at low speeds and heavy loads need to be lubricated by high viscosity greases, and if possible, with very good EP characteristics.

Solid additives such as graphite and molybdenum disulphide (MoS_2) can be considered for a speed factor $A < 20\,000$. Selecting the proper grease and grease fill is very important in low speed applications.

High speeds

Relubrication intervals for bearings used at high speeds i.e. above the recommended speed factor A provided in **table 1**, **page 239**, only apply when using special greases or modified bearing executions, e.g. hybrid bearings. In these cases continuous relubrication techniques such as circulating oil, oil-spot etc, are more suitable than grease lubrication.

Very heavy loads

For bearings operating at a speed factor $A > 20\,000$ and subjected to a load ratio $C/P < 4$ the relubrication interval is further reduced. Under these very heavy load conditions, continuous grease relubrication or oil bath lubrication is recommended.

In applications where the speed factor $A < 20\,000$ and the load ratio $C/P = 1-2$, reference should be made to the information under "Very low speeds" on **page 240**. For heavy loads and high speeds circulating oil lubrication with cooling is generally recommended.

Very light loads

In many cases the relubrication interval may be extended if the loads are light ($C/P = 30$ to 50). To obtain satisfactory operation the bearings should be subjected at least to the minimum load as stated in the text preceding the relevant product tables.

Misalignment

A constant misalignment within the permissible limits does not adversely affect the grease life in spherical roller bearings, self-aligning ball bearings or toroidal roller bearings.

Large bearings

To establish a proper relubrication interval for line contact bearings, in particular large bearings ($d > 300$ mm) used in critical bearing arrangements in process industries, an interactive procedure is recommended. In these cases it is advisable to initially relubricate more frequently and adhere strictly to the recommended regreasing quantities (→ section "Relubrication procedures" on **page 242**).

Before regreasing, the appearance of the used grease and the degree of contamination due to particles and water should be checked. Also the seal should be checked completely, looking for wear, damage and leaks. When the condition of the grease and associated components is found to be satisfactory, the relubrication interval can be gradually increased.

A similar procedure is recommended for spherical roller thrust bearings, prototype machines and upgrades of high-density power equipment or wherever application experience is limited.

Cylindrical roller bearings

The relubrication intervals from **diagram 4**, **page 238**, are valid for cylindrical roller bearings fitted with

- an injection moulded cage of glass fibre reinforced polyamide 6,6, roller centred, designation suffix P
- a two-piece machined brass cage, roller centred, designation suffix M.

For cylindrical roller bearings with

- a pressed steel cage, roller centred, no designation suffix or suffix J, or
- a machined brass cage, inner or outer ring centred, designation suffixes MA, MB, ML or MP,

the value for the relubrication interval from **diagram 4** should be halved and a grease with good oil bleeding properties should be applied. Moreover, grease lubricated bearings with a MA, MB, ML or MP cage should not be operated at speeds exceeding the speed factor $A = n \times d_m = 250\,000$. For applications exceeding this value, please consult the SKF application engineering service. SKF generally recommends to lubricate these bearings with oil.

Observations

If the determined value for the relubrication interval t_r is too short for a particular application, it is recommended to

- check the bearing operating temperature
- check whether the grease is contaminated by solid particles or fluids
- check the bearing application conditions, such as load or misalignment

and, last but not least, a more suitable grease should be considered.

Relubrication procedures

The choice of the relubrication procedure generally depends on the application and on the relubrication interval t_f obtained:

- Replenishment is a convenient and preferred procedure if the relubrication interval is shorter than six months. It enables uninterrupted operation and provides, when compared with continuous relubrication, a lower steady state temperature.
- Renewing the grease fill is generally recommended when the relubrication intervals are longer than six months. This procedure is often applied as part of a bearing maintenance schedule e.g. in railway applications.
- Continuous relubrication is used when the estimated relubrication intervals are short, e.g. due to the adverse effects of contamination, or when other procedures of relubrication are inconvenient because access to the bearing is difficult. Continuous relubrication is not recommended for applications with high rotational speeds since the intensive churning of the grease can lead to very high operating temperatures and destruction of the grease thickener structure.

When using different bearings in a bearing arrangement it is common practice to apply the lowest estimated relubrication interval for both bearings. The guidelines and grease quantities for the three alternative procedures are provided below.

Replenishment

As mentioned in the introduction of the grease lubrication section, the bearing should initially be completely filled, while the free space in the housing should be partly filled. Depending on the intended method of replenishment, the following grease fill percentages for this free space in the housing are recommended:

- 40 % when replenishing is made from the side of the bearing (→ **fig. 1**).
- 20 % when replenishing is made through the annular groove and lubrication holes in the bearing outer or inner ring (→ **fig. 2**).

Suitable quantities for replenishment from the side of a bearing can be obtained from

$$G_p = 0,005 D B$$

and for replenishment through the bearing outer or inner ring from

$$G_p = 0,002 D B$$

where

G_p = grease quantity to be added when replenishing, g

D = bearing outside diameter, mm

B = total bearing width (for thrust bearings use height H), mm

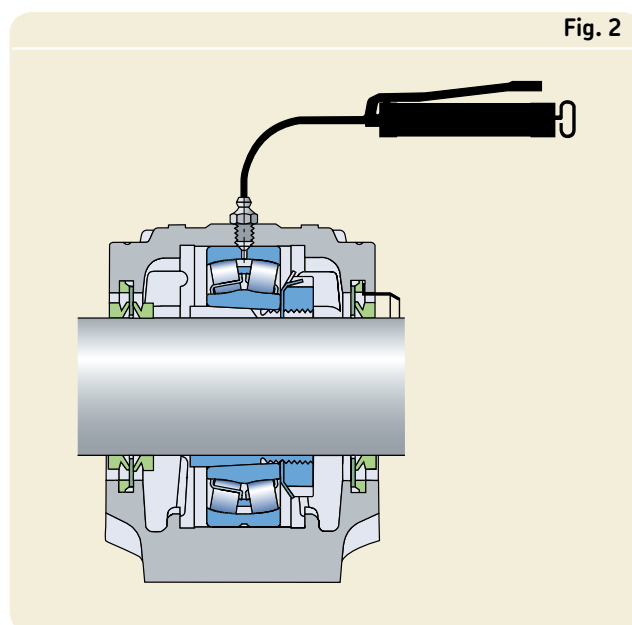
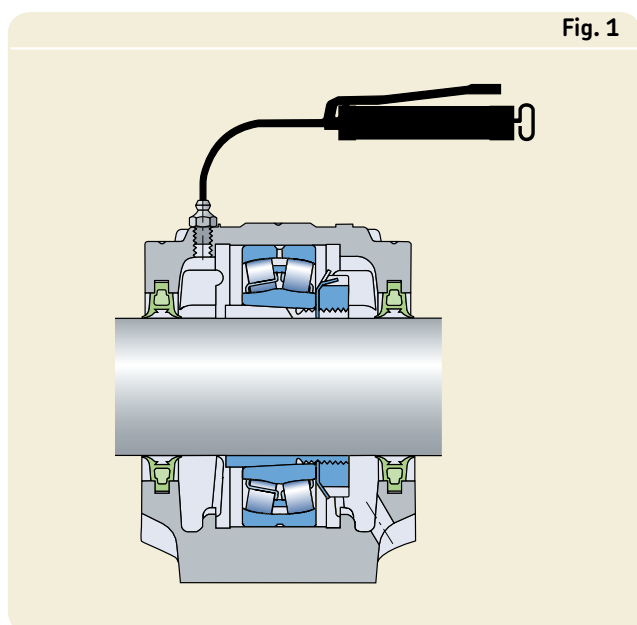

To facilitate the supply of grease using a grease gun, a grease nipple must be provided on the housing. If contact seals are used, an exit hole in the housing should also be provided so that excessive amounts of grease will not build up in the space surrounding the bearing (→ **fig. 1**) as this might cause a permanent increase in bearing temperature. The exit hole should be plugged when high-pressure water is used for cleaning.

The danger of excess grease collecting in the space surrounding the bearing and causing temperature peaks, with its detrimental effect on the grease as well as the bearing, is more pronounced when bearings operate at high speeds. In these cases it is advisable to use a grease escape valve rather than an exit hole. This prevents over-lubrication and enables relubrication to be performed while the machine is in operation. A grease escape valve consists basically of a disc that rotates with the shaft and which forms a narrow gap together with the housing end cover (→ **fig. 3**). Excess and used grease are thrown out by the disc into an annular cavity and leaves the housing through an opening on the underside of the end cover. Additional information about the design and dimensioning of grease escape valves can be supplied on request.

To be sure that fresh grease actually reaches the bearing and replaces the old grease, the lubrication duct in the housing should either feed the grease adjacent to the outer ring side face (→ **figs. 1** and **4**) or, better still, into the bearing. To facilitate efficient lubrication some bearing types, e.g. spherical roller bearings, are provided with an annular groove and/or lubrication holes in the outer or inner ring (→ **figs. 2** and **5**).

Fig. 3

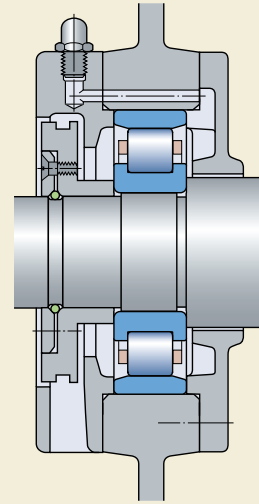

Fig. 4

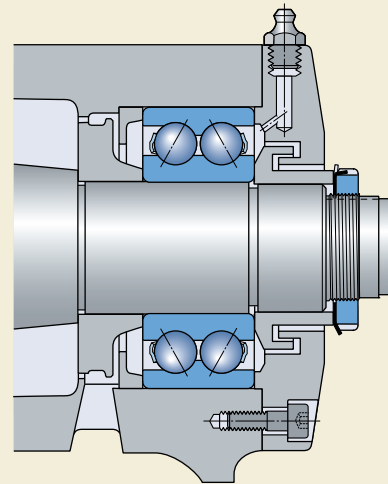
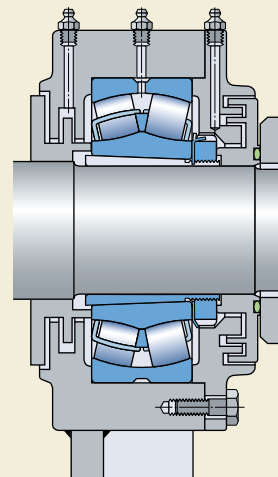

Fig. 5



Lubrication

To be effective in replacing old grease, it is important that grease is replenished while the machine is operating. In cases where the machine is not in operation, the bearing should be rotated during replenishment. When lubricating the bearing directly through the inner or outer ring, the fresh grease is most effective in replenishment; therefore, the amount of grease needed is reduced when compared with relubricating from the side. It is assumed that the lubrication ducts were already filled with grease during the mounting process. If not, a greater relubrication quantity during the first replenishment is needed to compensate for the empty ducts.

Where long lubrication ducts are used, check whether the grease can be adequately pumped at the prevailing ambient temperature.

The complete grease fill should be replaced when the free space in the housing can no longer accommodate additional grease, e.g. approximately above 75 % of the housing free volume. When relubricating from the side and starting with 40 % initial fill of the housing, the complete grease fill should be replaced after approximately five replenishments. Due to the lower initial fill of the housing and the reduced topping-up quantity during replenishment in the case of relubricating the bearing directly through inner or outer ring, renewal will only be required in exceptional cases.

Renewing the grease fill

When renewal of the grease fill is made at the estimated relubrication interval or after a certain number of replenishments, the used grease in the bearing arrangement should be completely removed and replaced by fresh grease.

Filling the bearing and housing with grease should be done in accordance with the guidelines provided under “Replenishment”.

To enable renewal of the grease fill the bearing housing should be easily accessible and easily opened. The cap of split housings and the covers of one-piece housings can usually be removed to expose the bearing. After removing the used grease, fresh grease should first be packed between the rolling elements. Great care should be taken to see that contaminants are not introduced into the bearing or housing when relubricating, and the grease itself should be protected. The use of grease resistant gloves is recommended to prevent any allergic skin reactions.

When housings are less accessible but are provided with grease nipples and exit holes, it is possible to completely renew the grease fill by relubricating several times in close succession, until it can be assumed that all old grease has been pressed out of the housing. This procedure requires much more grease than is needed for manual renewal of the grease fill. In addition, this method of renewal has a limitation with respect to rotational speeds: at high speeds it will lead to undue temperature increases caused by excessive churning of the grease.

Continuous relubrication

This procedure is used when the calculated relubrication interval is very short, e.g. due to the adverse effects of contamination, or when other procedures of relubrication are inconvenient, e.g. access to the bearing is difficult.

Due to the excessive churning of the grease, which can lead to increased temperature, continuous lubrication is only recommended when rotational speeds are low, i.e. at speed factors

- $A < 150\,000$ for ball bearings
- $A < 75\,000$ for roller bearings.

In these cases the initial grease fill of the housing may be 100 % and the quantity for relubrication per time unit is derived from the equations for G_p under “Replenishment” by spreading the relevant quantity over the relubrication interval.

When using continuous relubrication, check whether the grease can be adequately pumped through the ducts at the prevailing ambient temperature.

Continuous lubrication can be achieved via single-point or multi-point automatic lubricators, e.g. SYSTEM 24® or SYSTEM MultiPoint. For additional information refer to the section on “Maintenance and lubrication products”, starting on **page 1069**.

Customized automatic lubrication systems, e.g. by the VOGEL® total-loss centralized single or multi-line lubrication systems, enable reliable lubrication to be achieved with extremely small quantities of grease. For more information about the VOGEL lubrication systems, please visit www.vogelag.com.

Table 2

SKF greases – technical specification and characteristics

Part 1: Technical specification

Designation	Description	NLGI class	Thickener/ base oil	Base oil viscosity at		Temperature limits	
				40 °C	100 °C	LTL ¹⁾	HTPL ²⁾
–	–	–	–	mm ² /s		°C	
LGMT 2	All purpose industrial and automotive	2	Lithium soap/ mineral oil	110	11	–30	+120
LGMT 3	All purpose industrial and automotive	3	Lithium soap/ mineral oil	120	12	–30	+120
LGEP 2	Extreme pressure, heavy load	2	Lithium soap/ mineral oil	200	16	–20	+110
LGLT 2	Light load and low temperature, high speed	2	Lithium soap/ diester oil	15	3,7	–55	+100
LGHP 2	High performance and high temperature	2–3	Di-urea/ mineral oil	96	10,5	–40	+150
LGFP 2	Food compatible	2	Aluminium complex/ medical white oil	130	7,3	–20	+110
LGGB 2	Biodegradable and low toxicity	2	Lithium-calcium soap/ ester oil	110	13	–40	+120
LGWA 2	Wide temperature range	2	Lithium complex soap/ mineral oil	185	15	–30 peaks:	+140 +220
LGHB 2	High viscosity and high temperature	2	Calcium complex sulphonate/mineral oil	450	26,5	–20 peaks:	+150 +200
LGET 2	Extreme temperature	2	PTFE/synthetic (fluorinated polyether)	400	38	–40	+260
LGEM 2	High viscosity with solid lubricants	2	Lithium soap/ mineral oil	500	32	–20	+120
LGEV 2	Extreme high viscosity with solid lubricants	2	Lithium-calcium soap/ mineral oil	1 000	58	–10	+120
LGWM 1	Extreme pressure, low temperature	1	Lithium soap/ mineral oil	200	16	–30	+110

¹⁾LTL: low temperature limit. For safe operating temperature, → section “Temperature range – the SKF traffic light concept”, starting on **page 232**

²⁾HTPL: high temperature performance limit

Table 2

SKF greases – technical specification and characteristics

Part 2: Characteristics

Designation	High temperature, above +120 °C	Low temperature ¹⁾	Very high speed	Very low speed or oscillations	Low torque, low friction	Severe vibrations	Heavy loads	Rust inhibiting properties	Water resistance
LGMT 2			0	-	+	+	0	+	+
LGMT 3			0	-	0	+	0	0	+
LGEP 2			0	0	-	+	+	+	+
LGLT 2		+	+	-	+	-	-	0	0
LGHP 2	+	0	+	-	0	+	0	+	+
LGFP 2			0	-	0	0		+	+
LGGB 2		0	0	0	0	+	+	0	+
LGWA 2	+		0	0	0	+	+	+	+
LGHB 2	+		0	+	-	+	+	+	+
LGEM 2				Contact the SKF application engineering service					
LGEM 2			-	+	-	+	+	+	+
LGEV 2		-	-	+	-	+	+	+	+
LGWM 1		+	0	0	0	-	+	+	+

Symbols: + Recommended
 0 Suitable
 - Not suitable

Where no symbol is indicated the relevant grease may be used – however it is not recommended.

For further information please contact the SKF application engineering service

¹⁾For safe operating temperature, → section “Temperature range – the SKF traffic light concept”, starting on page 232

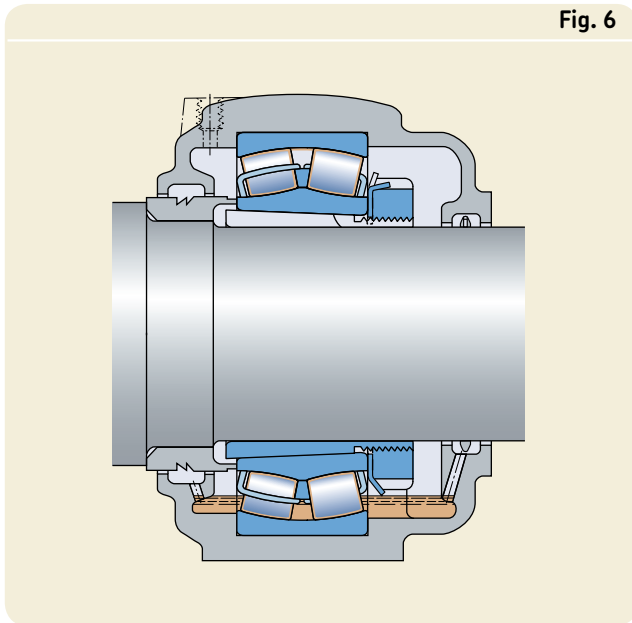

Fig. 6

Oil lubrication

Oil is generally used for rolling bearing lubrication when high speeds or operating temperatures preclude the use of grease, when frictional or applied heat has to be removed from the bearing position, or when adjacent components (gears etc.) are lubricated with oil.

In order to increase bearing service life, all methods of bearing lubrication that use clean oil are preferred, i.e. well filtered circulating oil lubrication, oil jet method and the oil-spot method with filtered air and oil. When using the circulating oil and oil-spot methods, adequately dimensioned ducts must be provided so that the oil flowing from the bearing can leave the arrangement.

Methods of oil lubrication

Oil bath

The simplest method of oil lubrication is the oil bath (→ **fig. 6**). The oil, which is picked up by the rotating components of the bearing, is distributed within the bearing and then flows back to the oil bath. The oil level should be such that it almost reaches the centre of the lowest rolling element when the bearing is stationary. The use of oil levellers such as the SKF LAHD 500 is recommended to provide the correct oil level. When operating at high speed the oil level can drop significantly and the housing can become over-filled by the oil leveller, under these conditions, please consult the SKF application engineering service.

Oil pick-up ring

For bearing applications where speeds and operating temperature are such that oil lubrication is necessary and high reliability is required, the oil pick-up ring lubrication method is recommended (→ **fig. 7**). The pick-up ring serves to bring about oil circulation. The ring hangs loosely on a sleeve on the shaft on one side of the bearing and dips into the oil in the lower half of the housing. As the shaft rotates, the ring follows and transports oil from the bottom to a collecting trough. The oil then flows through the bearing back into the reservoir at the bottom. SKF plummer block housings in the SONL series are designed for the oil pick-up ring lubrication method. For additional information please consult the SKF application engineering service.

Circulating oil

Operation at high speeds will cause the operating temperature to increase and will accelerate ageing of the oil. To avoid frequent oil changes and to achieve a fully flooded condition, the circulating oil lubrication method is generally preferred (→ **fig. 8**). Circulation is usually produced with the aid of a pump. After the oil has passed through the bearing, it generally settles in a tank where it is filtered and, if required, cooled before being returned to the bearing. Proper filtering leads to high values for the factor η_c and thus to long bearing service life (→ section “SKF rating life”, starting on **page 52**).

Cooling the oil enables the operating temperature of the bearing to be kept at a low level.

Fig. 7

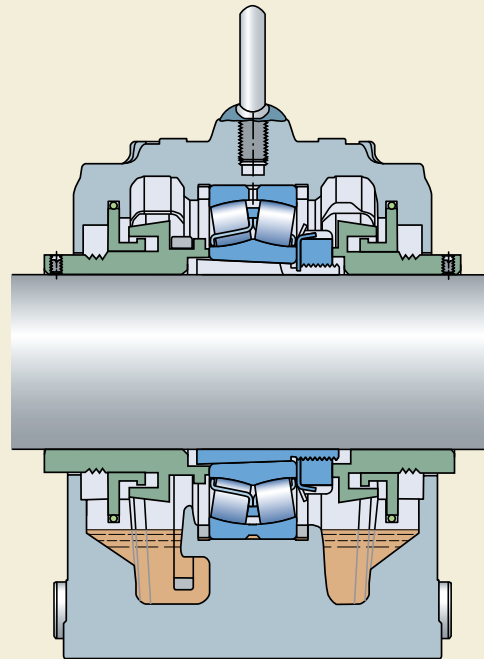

Fig. 8

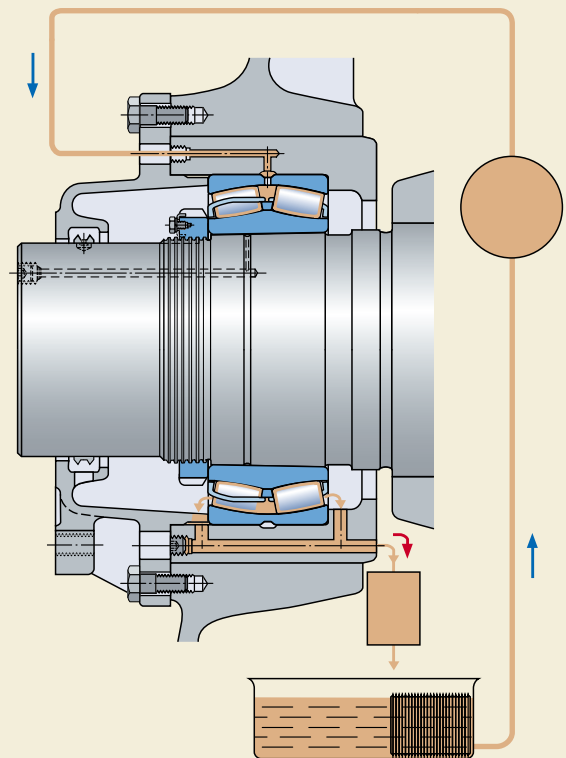
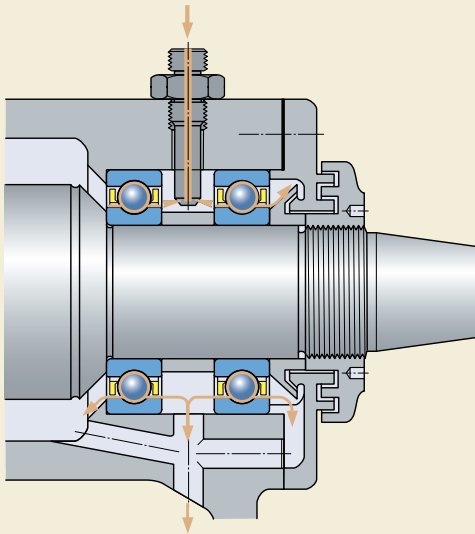

Fig. 9



Oil jet

For very high-speed operation a sufficient but not excessive amount of oil must be supplied to the bearing to provide adequate lubrication, without increasing the operating temperature more than necessary. One particularly efficient method of achieving this is the oil jet method (→ fig. 9) where a jet of oil under high pressure is directed at the side of the bearing. The velocity of the oil jet must be sufficiently high (at least 15 m/s) to penetrate the turbulence surrounding the rotating bearing.

Oil-spot

With the oil-spot method (→ fig. 10) – also called the oil-air method – very small, accurately metered quantities of oil are directed at each individual bearing by compressed air. This minimum quantity enables bearings to operate at lower temperatures or at higher speeds than any other method of lubrication. The oil is supplied to the leads by a metering unit, such as the VOGEL OLA oil + air systems, at given intervals. The oil is transported by compressed air; it coats the inside of the leads and “creeps” along them. It is projected to the bearing via a nozzle or it just flows to the bearing raceways by a surface tension effect. The compressed air serves to cool the bearing and also produces an excess pressure in the bearing arrangement to prevent contaminants from entering.

For more information about the design of oil-air lubrication arrangements, please refer to the VOGEL publication 1-5012-3 “Oil + Air Systems” or visit www.vogelag.com.

Oil mist

Oil mist lubrication has not been recommended for some time due to possible negative environmental effects.

A new generation of oil mist generators permits to produce oil mist with 5 ppm oil. New designs of special seals also limit the amount of stray mist to a minimum. In case synthetic non-toxic oil is used, the environmental effects are even further reduced. Oil mist lubrication today is used in very specific applications, like the petroleum industry.

Fig. 10

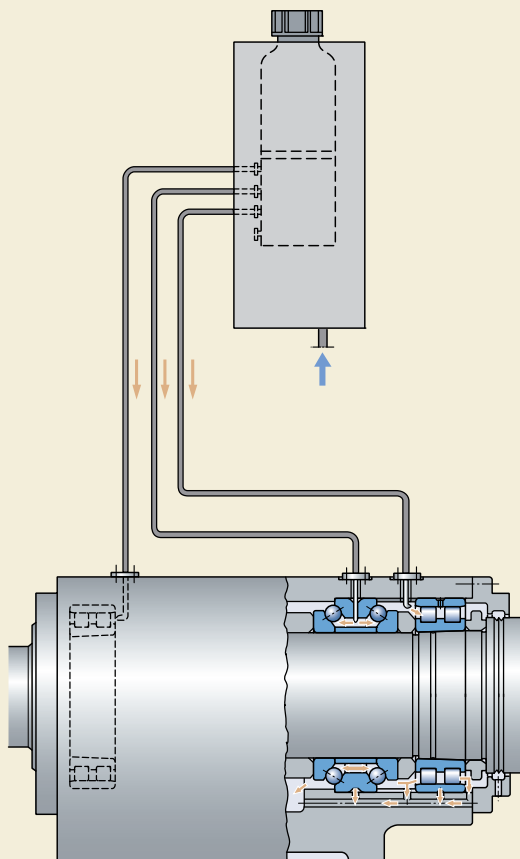

Lubricating oils

Straight mineral oils are generally favoured for rolling bearing lubrication. Oils containing EP, antiwear and other additives for the improvement of certain lubricant properties are generally only used in special cases. The remarks covering EP additives in the section “Load carrying ability: EP and AW additives” on **page 234** also apply to those additives in oils.

Synthetic versions of many of the popular lubricant classes are available. Synthetic oils are generally only considered for bearing lubrication in extreme cases, e.g. at very low or very high operating temperatures. The term synthetic oil covers a wide range of different base stocks. The main ones are polyalphaolefins (PAO), esters and polyalkylene glycols (PAG). These synthetic oils have different properties to mineral oils (→ **table 3**).

With respect to bearing fatigue life the actual lubricant film thickness plays a major role. The oil viscosity, the viscosity index and the pressure-viscosity coefficient influence the actual film thickness in the contact area for a fully flooded condition. For most mineral oil based lubricants, the pressure-viscosity coefficient is similar and generic values obtained from literature can be used without large error. However, the response of viscosity to increasing pressure is determined by the chemical structure of the base stocks used. As a result of this there is considerable variation in pressure-viscosity coefficients for the different types of synthetic base stocks. Due to the differences in the viscosity index and pressure-viscosity coefficient, it

should be remembered that the lubricant film formation, when using synthetic oil, may differ from that of a mineral oil having the same viscosity. Accurate information should always be sought from the individual lubricant supplier.

In addition, additives play a role in the film formation. Due to differences in solubility, different types of additives are applied in synthetic oils when compared with the mineral oil based counterparts.

Table 3

Properties of oil types				
Properties	Base oil type Mineral	PAO	Ester	PAG
Pour point (°C)	-30 .. 0	-50 .. -40	-60 .. -40	appr. - 30
Viscosity index	low	moderate	high	high
Pressure-viscosity coefficient	high	moderate	low to moderate	high

Selection of lubricating oils

Selecting oil is primarily based on the viscosity required to provide adequate lubrication for the bearing at the bearing operating temperature. The viscosity of oil is temperature dependent, becoming lower as the temperature rises. The viscosity-temperature relationship of an oil is characterized by the viscosity index VI. For rolling bearing lubrication, oils having a high viscosity index (little change with temperature) of at least 95 are recommended.

In order for a sufficiently thick oil film to be formed in the contact area between rolling elements and raceways, the oil must retain a minimum viscosity at the operating temperature. The minimum kinematic viscosity ν_1 required at the operating temperature to provide adequate lubrication can be determined from **diagram 5, page 254**, provided a mineral oil is used. When the operating temperature is known from experience or can otherwise be determined, the corresponding viscosity at the internationally standardized reference temperature of 40 °C, i.e. the oil ISO VG viscosity class, can be obtained from **diagram 6, page 255**, which is compiled for a viscosity index of 95.

Certain bearing types, e.g. spherical roller bearings, toroidal roller bearings, taper roller bearings, and spherical roller thrust bearings, normally have a higher operating temperature than other bearing types, e.g. deep groove ball bearings and cylindrical roller bearings, under comparable operating conditions.

When selecting the oil the following aspects should be considered:

- Bearing life may be extended by selecting an oil where the kinematic viscosity ν at the operating temperature is higher than the viscosity ν_1 obtained from **diagram 5**. A $\nu > \nu_1$ can be obtained by choosing a mineral oil of higher ISO VG viscosity class or by taking an oil with higher viscosity index VI, whereby this oil should have at least the same pressure-viscosity coefficient. Since increased viscosity raises the bearing operating temperature there is frequently a practical limit to the lubrication improvement that can be obtained by this means.

- If the viscosity ratio $\kappa = \nu/\nu_1$ is less than 1, an oil containing EP additives is recommended and if κ is less than 0,4 an oil with EP additives must be used. An oil with EP additives may also enhance operational reliability in cases where κ is greater than 1 and medium and large-size roller bearings are concerned. It should be remembered that some EP additives may have adverse effects (→ “Load carrying ability: EP and AW additives” on **page 234**).
- For exceptionally low or high speeds, for critical loading conditions, or for unusual lubricating conditions please consult the SKF application engineering service.

Example

A bearing having a bore diameter $d = 340$ mm and outside diameter $D = 420$ mm is required to operate at a speed $n = 500$ r/min. Therefore $d_m = 0,5 (d + D) = 380$ mm. From **diagram 5**, the minimum kinematic viscosity ν_1 required for adequate lubrication at the operating temperature is approximately 11 mm²/s. From **diagram 6**, assuming that the operating temperature of the bearing is 70 °C, it is found that a lubricating oil of ISO VG 32 viscosity class, i.e. a kinematic viscosity ν of at least 32 mm²/s at the reference temperature of 40 °C, will be required.

Oil change

The frequency with which it is necessary to change the oil depends mainly on the operating conditions and the quantity of oil.

With oil bath lubrication it is generally sufficient to change the oil once a year, provided the operating temperature does not exceed 50 °C and there is little risk of contamination. Higher temperatures call for more frequent oil changes, e.g. for operating temperatures around 100 °C, the oil should be changed every three months. Frequent oil changes are also needed if other operating conditions are arduous.

With circulating oil lubrication, the period between two oil changes is also determined by how frequently the total oil quantity is circulated and whether or not the oil is cooled. It is generally only possible to determine a suitable interval by test runs and by regular inspection of the condition of the oil to see that it is not contaminated and is not excessively oxidized. The same applies for oil jet lubrication. With oil spot lubrication the oil only passes through the bearing once and is not recirculated.

Estimation of the minimum kinematic viscosity ν_1 at operating temperature

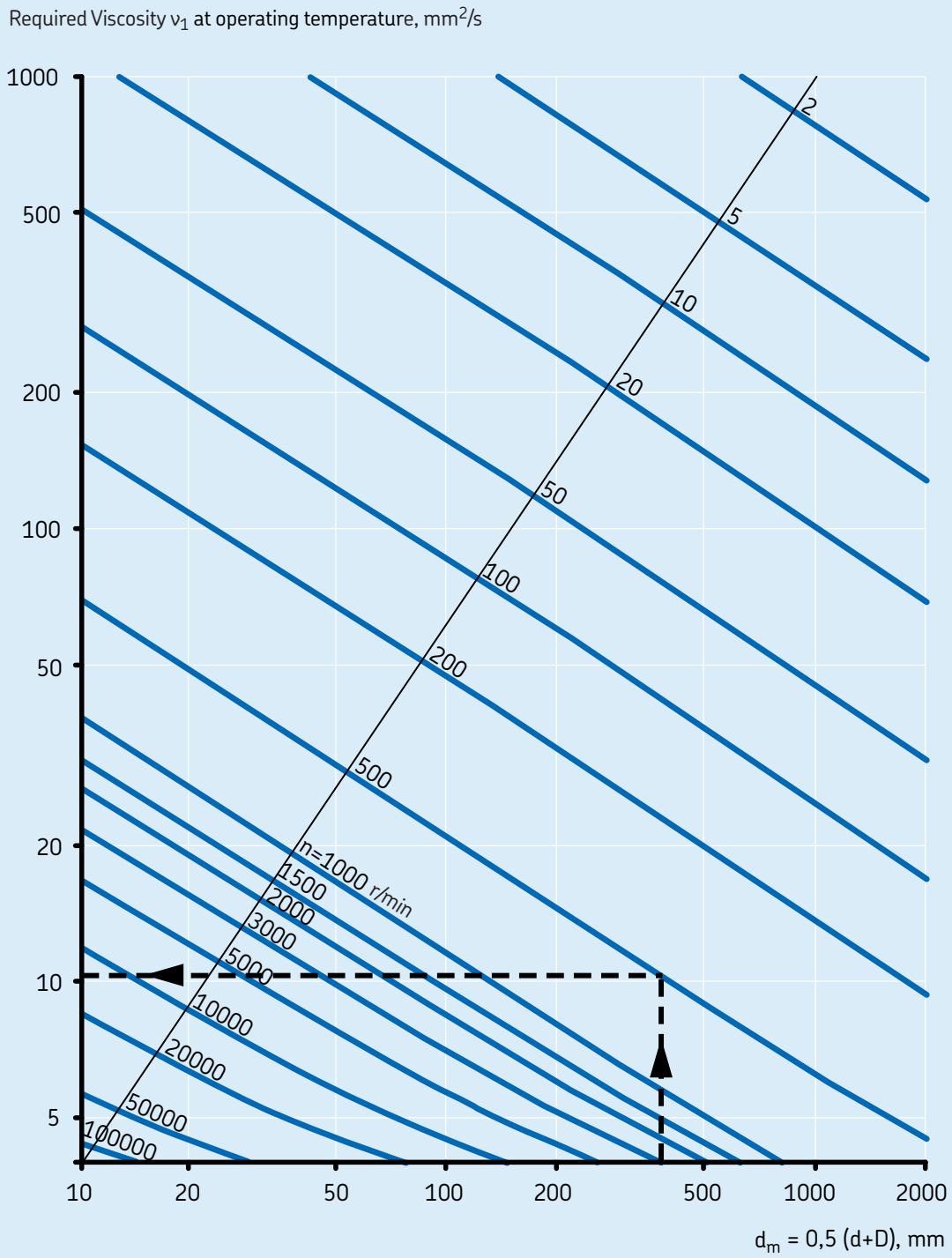

Conversion to kinematic viscosity ν at reference temperature (ISO VG classification)

Required viscosity ν_1 at operating temperature, mm^2/s

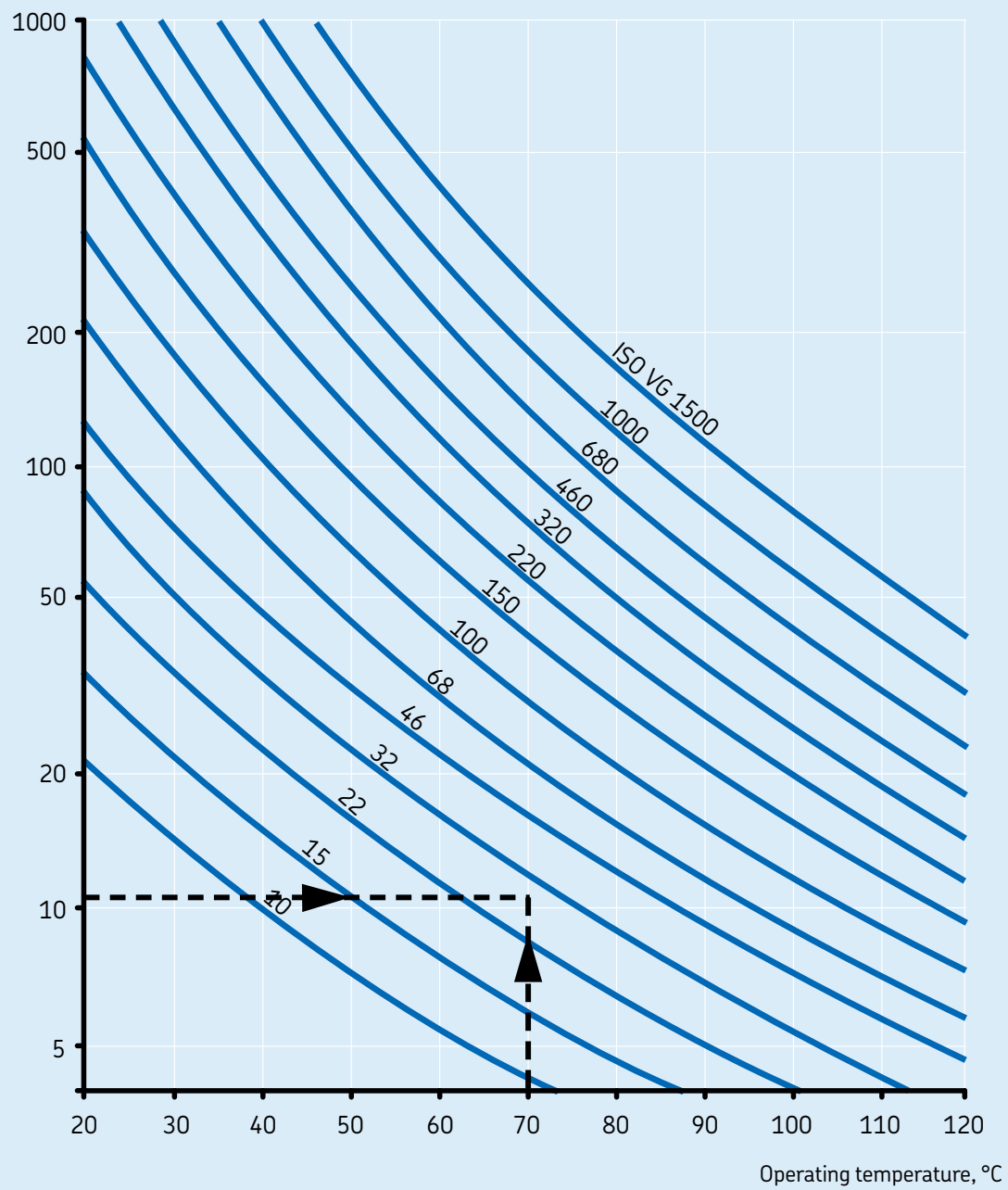



Mounting and dismounting

General information	258
Where to mount	258
Preparations for mounting and dismounting	258
Bearing handling	260
Mounting.....	261
Mounting bearings with a cylindrical bore	261
Bearing adjustment	262
Mounting bearings with a tapered bore	263
Test running.....	267
Dismounting.....	268
Dismounting bearings with a cylindrical bore.....	268
Dismounting bearings with a tapered bore.....	270
Bearing storage	273
Inspection and cleaning	273

General information

To provide proper bearing performance and prevent premature failure, skill and cleanliness when mounting ball and roller bearings are necessary.

As precision components, rolling bearings should be handled carefully when mounting. It is also important to choose the correct method of mounting and to use the correct tools for the job. The comprehensive SKF range of maintenance products includes mechanical and hydraulic tools and heating equipment as well as other products for mounting and maintenance. This full line of products will facilitate and speed the work, giving professional results. Brief information can be found in the section “Maintenance and lubrication products”, starting on **page 1065**.

To realize maximum bearing service life, a bearing must be installed correctly – which often is more difficult than it appears, especially where large size bearings are concerned. To be sure that bearings are mounted and maintained properly, SKF offers seminars and hands-on training courses as part of the SKF Reliability Systems concept. Installation and maintenance assistance may also be available from your local SKF company.

The information provided in the following section is quite general and is intended primarily to indicate what must be considered by machine and equipment designers in order to facilitate bearing mounting and dismounting. More detailed descriptions of the actual mounting and dismounting procedures can be found in the publication “SKF Bearing Maintenance Handbook” which is available through your local SKF representative on request, or online at www.skf.com/mount or www.apitudexchange.com.

Where to mount

Bearings should be installed in a dry, dust-free room away from metalworking or other machines producing swarf and dust. When bearings have to be mounted in an unprotected area, which is often the case with large bearings, steps need to be taken to protect the bearing and mounting position from contamination by dust, dirt and moisture until installation has been completed. This can be done by covering or wrapping bearings, machine components etc. with waxed paper or foil.

Preparations for mounting and dismounting

Before mounting, all the necessary parts, tools, equipment and data need to be at hand. It is also recommended that any drawings or instructions be studied to determine the correct order in which to assemble the various components.

Housings, shafts, seals and other components of the bearing arrangement need to be checked to make sure that they are clean, particularly any threaded holes, leads or grooves where remnants of previous machining operations might have collected. The unmachined surfaces of cast housings need to be free of core sand and any burrs need to be removed.

The dimensional and form accuracy of all components of the bearing arrangement needs to be checked. The bearings will only perform satisfactorily if the associated components have the requisite accuracy and if the prescribed tolerances are adhered to. The diameter of cylindrical shaft and housing seatings are usually checked using a stirrup or internal gauge at two cross-sections and in four directions (→ **fig. 1**). Tapered bearing seatings are checked using ring gauges, special taper gauges or sine bars.

It is advisable to keep a record of the measurements. When measuring it is important that the components being measured and the measuring instruments have approximately the same temperature. This means that it is necessary to leave the components and measuring equipment together in the same place sufficiently long for them to reach the same temperature. This is particularly important where large bearings and their associated components, which are correspondingly large and heavy, are concerned.

The bearings need to be left in their original packages until immediately before mounting so

that they will not be exposed to any contaminants, especially dirt. Normally, the preservative with which new bearings are coated before leaving the factory does not need to be removed; it is only necessary to wipe off the outside cylindrical surface and bore. If, however, the bearing is to be grease lubricated and used at very high or very low temperatures, or if the grease is not compatible with the preservative, it is necessary to wash and carefully dry the bearing. This is to avoid any detrimental effect on the lubricating properties of the grease.

Bearings should be washed and dried before mounting if there is a risk that they have become contaminated because of improper handling (damaged packaging etc.).

When taken from its original packaging, any bearing that is covered by a relatively thick, greasy layer of preservative should also be washed and dried. This might be the case for some large bearings with an outside diameter larger than 420 mm. Suitable agents for washing rolling bearings include white spirit and paraffin.

Bearings that are supplied ready greased and which have integral seals or shields on both sides should not be washed before mounting.

Fig. 1

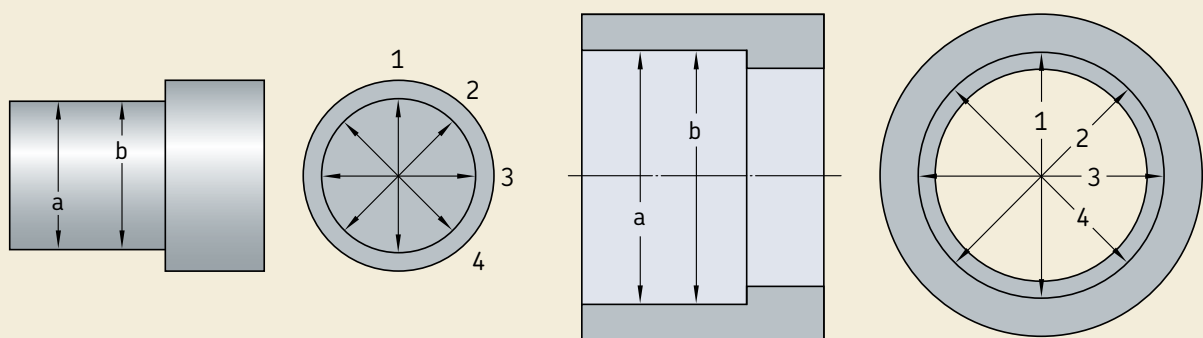

Mounting and dismounting

Bearing handling

It is generally a good idea to use gloves as well as carrying and lifting tools, which have been specially designed for mounting and dismounting bearings. This will save not only time and money but the work will also be less tiring, less risky and less injurious to health.

For these reasons, the use of heat and oil resistant gloves is recommended when handling hot or oily bearings. These gloves should have a durable outside and a soft non-allergenic inside, as, for example, SKF TMBA gloves.

Heated and/or larger or heavier bearings often cause problems because they cannot be handled in a safe and efficient manner by one or two persons. Satisfactory arrangements for carrying and lifting these bearings can be made on site in a workshop. The bearing handling tool TMMH from SKF (→ **fig. 2**) is one such arrangement, which solves most of the problems and facilitates handling, mounting and dismounting bearings on shafts.

If large, heavy bearings are to be moved or held in position using lifting tackle, they should not be suspended at a single point, but a steel band or fabric belt should be used (→ **fig. 3**). A spring between the hook of the lifting tackle and the belt facilitates positioning the bearing when it is to be pushed onto a shaft.

To ease lifting, large bearings can be provided on request with threaded holes in the ring side faces to accommodate eye bolts. The hole size is limited by the ring thickness. It is therefore only permissible to lift the bearing itself or the individual ring by the bolts. Make also sure that the eye bolts are only subjected to load in the direction of the shank axis (→ **fig. 4**). If the load is to be applied at an angle, suitable adjustable attachments are required.

When mounting a large housing over a bearing that is already in position on a shaft it is advisable to provide three-point suspension for the housing, and for the length of one sling to be adjustable. This enables the housing bore to be exactly aligned with the bearing.



Fig. 2

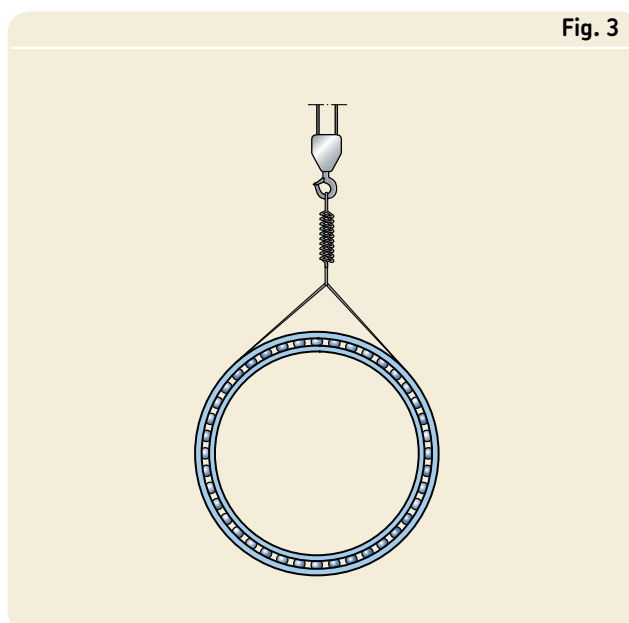

Fig. 3

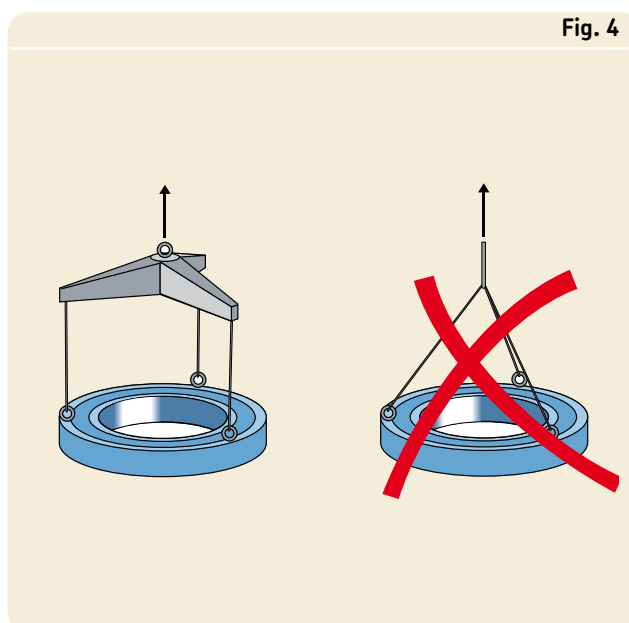

Fig. 4

Fig. 5

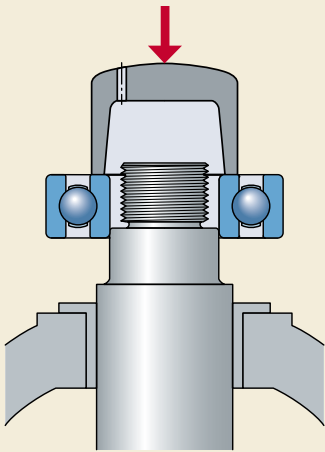

Fig. 6

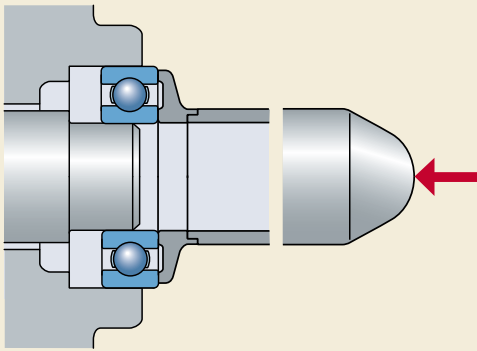
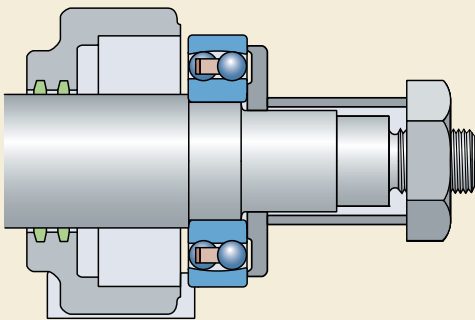

Fig. 7



Mounting

Depending on the bearing type and size, mechanical, thermal or hydraulic methods are used for mounting. In all cases it is important that the bearing rings, cages and rolling elements or seals do not receive direct blows and that the mounting force must never be directed through the rolling elements.

Some parts may be mounted with a loose fit. To avoid any fretting corrosion between the mating surfaces, it is recommended to apply a thin layer of SKF anti-fretting agent LGAF 3 E.

Mounting bearings with a cylindrical bore

With non-separable bearings, the ring that is to have the tighter fit should generally be mounted first. The seating surface should be lightly oiled with thin oil before mounting.

Cold mounting

If the fit is not too tight, small bearings may be driven into position by applying light hammer blows to a sleeve placed against the bearing ring face. The blows should be evenly distributed around the ring to prevent the bearing from tilting or skewing. The use of a mounting dolly instead of a sleeve enables the mounting force to be applied centrally (→ fig. 5).

If a non-separable bearing is to be pressed onto the shaft and into the housing bore at the same time, the mounting force has to be applied equally to both rings and the abutment surfaces of the mounting tool must lie in the same plane. In this case a bearing fitting tool should be used, where an impact ring abuts the side faces of the inner and outer rings and the sleeve enables the mounting forces to be applied centrally (→ fig. 6).

With self-aligning bearings, the use of an intermediate mounting ring prevents the outer ring from tilting and swivelling when the bearing with shaft is introduced into the housing bore (→ fig. 7). It should be remembered that the balls of some sizes of self-aligning ball bearings protrude from the side faces of the bearing, so that the intermediate mounting ring should be recessed in order not to damage the balls. Large numbers of bearings are generally mounted using mechanical or hydraulic presses.

Mounting and dismounting

With separable bearings, the inner ring can be mounted independently of the outer ring, which simplifies mounting, particularly where both rings are to have an interference fit. When installing the shaft, with the inner ring already in position, into the housing containing the outer ring, make sure that they are correctly aligned to avoid scoring the raceways and rolling elements. When mounting cylindrical and needle roller bearings with an inner ring without flanges or a flange at one side, SKF recommends using a mounting sleeve (→ **fig. 8**). The outside diameter of the sleeve should be equal to the raceway diameter F of the inner ring and should be machined to a $d10$ tolerance.

Hot mounting

It is generally not possible to mount larger bearings in the cold state, as the force required to mount a bearing increases very considerably with increasing bearing size. The bearings, the inner rings or the housings (e.g. hubs) are therefore heated prior to mounting.

The requisite difference in temperature between the bearing ring and shaft or housing depends on the degree of interference and the diameter of the bearing seating. Bearings should not be heated to more than 125 °C as otherwise dimensional changes caused by alterations in the structure of the bearing material may occur. Bearings fitted with shields or seals should not be heated above 80 °C because of their grease fill or seal material.

When heating bearings, local overheating must be avoided. To heat bearings evenly, SKF electric induction heaters (→ **fig. 9**) are recommended. If hotplates are used, the bearing must be turned over a number of times. Hotplates should not be used for heating sealed bearings

Bearing adjustment

The internal clearance of single row angular contact ball bearings and taper roller bearings is only established, in contrast to other radial bearings with cylindrical bore, when one bearing is adjusted against a second bearing. Usually these bearings are arranged in pairs either back-to-back or face-to-face, and one bearing ring is axially displaced until a given clearance or preload is attained. The choice of clearance or preload depends on the demands placed on the performance of the bearing arrangement and on the operating conditions. Additional information about bearing preloads can be found in the section “Bearing preload”, starting on **page 206**, so that the recommendations in the following refer only to the adjustment of internal

Fig. 8

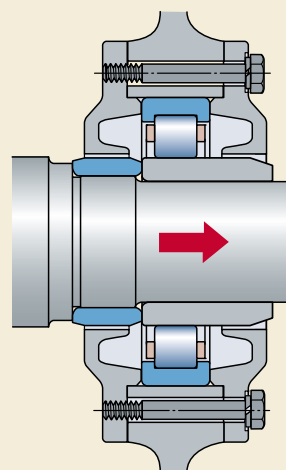

Fig. 9



clearance in bearing arrangements with angular contact ball bearings and taper roller bearings.

The appropriate value for the clearance to be obtained when mounting is determined by the conditions when the bearing is under load and at the operating temperature. Depending on the size and arrangement of the bearings, the materials from which the shaft and housing are made and the distance between the two bearings, the initial clearance obtained on mounting may be smaller or larger in actual operation. If, for example, differential thermal expansion of inner and outer rings will cause a reduction in clearance during operation, the initial clearance must be sufficiently large so that distortion of the bearings and the detrimental consequences of this are avoided.

Since there is a definite relationship between the radial and axial internal clearance of angular contact ball bearings and taper roller bearings, it is sufficient to specify one value, generally the axial internal clearance. This specified value is then obtained, from a condition of zero clearance, by loosening or tightening a nut on the shaft or a threaded ring in the housing bore, or by inserting calibrated washers or shims between one of the bearing rings and its abutment. The actual methods used to adjust the clearance and measure the set clearance are determined by whether a few or many bearings are to be mounted.

One method is to check the set axial clearance, for example, of a hub bearing arrangement, using a dial gauge attached to the hub (→ **fig. 10**). It is important when adjusting taper roller bearings and measuring the clearance that the shaft, or housing, is turned through several revolutions in both directions to be sure that there is proper contact of the roller ends with the guide flange on the inner ring. If the contact is not correct, the measured result will be inaccurate and the desired adjustment will not be achieved.

Mounting bearings with a tapered bore

For bearings having a tapered bore, inner rings are always mounted with an interference fit. The degree of interference is not determined by the chosen shaft tolerance, as with bearings having a cylindrical bore, but by how far the bearing is driven up onto the tapered shaft seating, or onto the adapter or withdrawal sleeve. As the bearing is driven up the tapered seating, its radial internal clearance is reduced. This reduction can be measured to determine the degree of interference and the proper fit.

When mounting self-aligning ball bearings, CARB toroidal roller bearings, spherical roller bearings, as well as high-precision cylindrical roller bearings with tapered bore, either the reduction in radial internal clearance or the axial drive-up onto the tapered seating is determined and used as a measure of the degree of interference. Guideline values of clearance reduction and axial drive-up are provided in the text preceding the relevant product table sections.

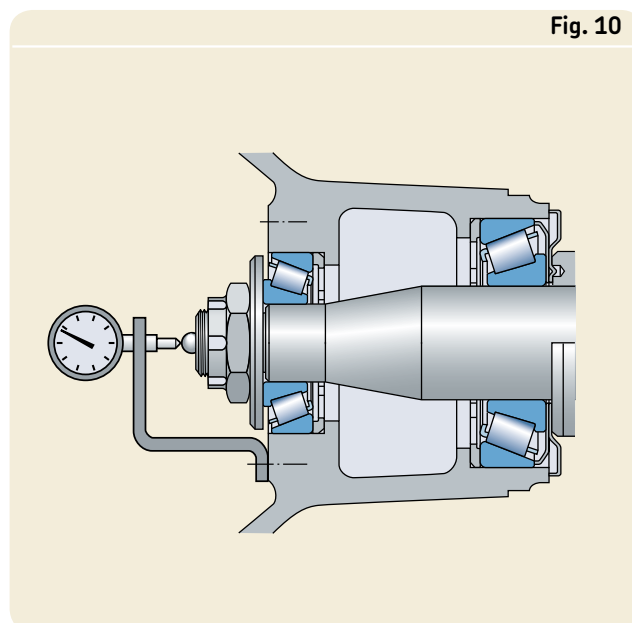

Mounting and dismounting

Small bearings

Small bearings may be driven up onto a tapered seating using a nut. In the case of adapter sleeves the sleeve nut is used. Small withdrawal sleeves may be driven into the bearing bore using a nut. A hook or impact spanner can be used to tighten the nut. The seating surfaces of the shaft and sleeve should be lightly oiled with thin oil before mounting is started.

Medium and large sized bearings

For larger bearings, considerably more force is required and

- SKF hydraulic nuts should be used and/or
- the oil injection method should be employed.

In either case, the mounting process will be considerably easier. The oil injection equipment required for both, operating the hydraulic nut as well as for applying the oil injection method, is available from SKF. Additional information about these products can be found in the section “Maintenance and lubrication products”, starting on **page 1065**.

When using an SKF hydraulic nut for mounting it has to be positioned onto a threaded section of the journal or onto the thread of the sleeve so that its annular piston abuts the inner ring of the bearing, a nut on the shaft, or a disc attached to the end of the shaft. Pumping oil into the hydraulic nut displaces the piston axially with the force needed for accurate and safe mounting. Mounting of a spherical roller bearing with the aid of a hydraulic nut on

- a tapered shaft seating is shown in **fig. 11**
- an adapter sleeve is shown in **fig. 12**
- a withdrawal sleeve is shown in **fig. 13**.

With the oil injection method, oil under high pressure is injected between the bearing and bearing seating to form an oil film. This oil film separates the mating surfaces and appreciably reduces the friction between them. This method is typically used when mounting bearings directly on tapered journals (→ **fig. 14**), but is also used to mount bearings on adapter and withdrawal sleeves that have been prepared for the oil injection method. A pump or oil injector produces the requisite pressure, the oil is injected between the mating surfaces via ducts and distributor grooves in the shaft or sleeve.

Fig. 11

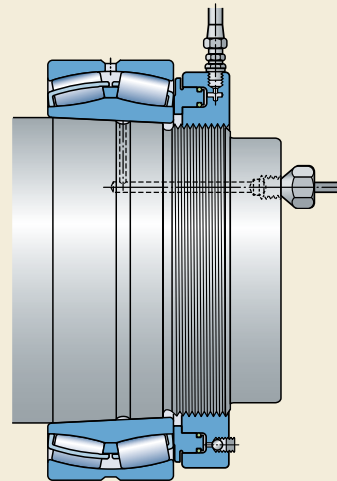

Fig. 12

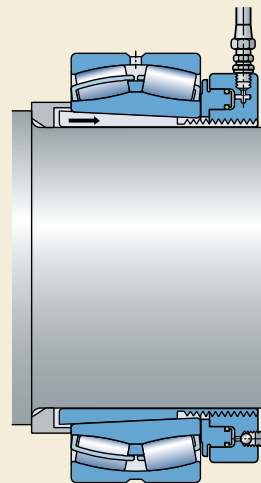

Fig. 13

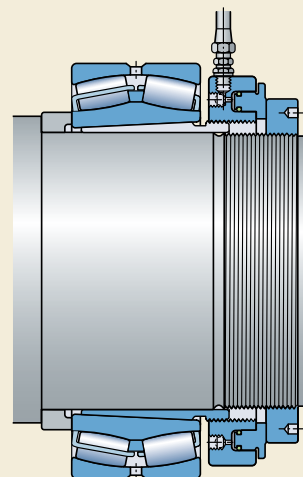
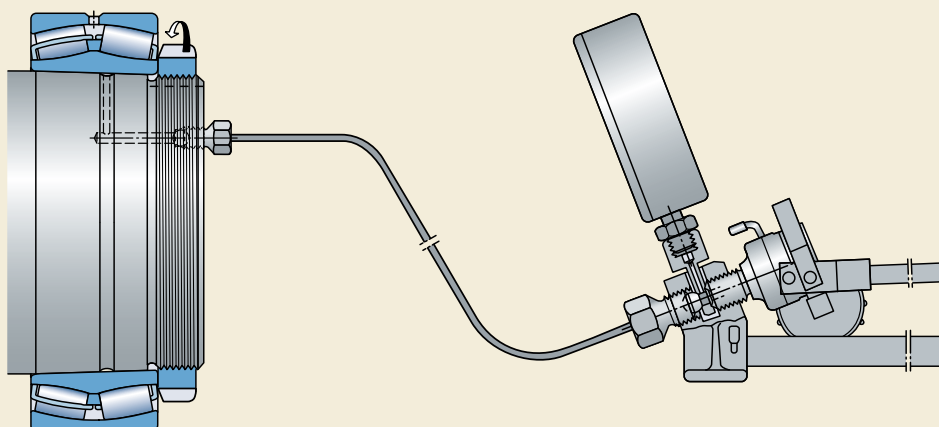

Fig. 14



The necessary ducts and grooves in the shaft must be considered when designing the bearing arrangement. A spherical roller bearing mounted on a withdrawal sleeve with oil ducts is shown in **fig. 15**. The withdrawal sleeve is pressed into the bearing bore by injecting oil between the mating surfaces and tightening the screws in turn.

Determination of the interference fit

Bearings with a tapered bore are always mounted with an interference fit. The reduction in radial internal clearance, or the axial displacement of the inner ring on its tapered seating is used to determine and measure the degree of interference.

Different methods can be used to measure the degree of interference:

1. Measuring the clearance reduction with a feeler gauge.
2. Measuring the lock nut tightening angle.
3. Measuring the axial drive-up.
4. Measuring the inner ring expansion.

A brief description of these four different methods is provided in the following. More detailed information about these methods can be found in the relevant product sections.

Fig. 15

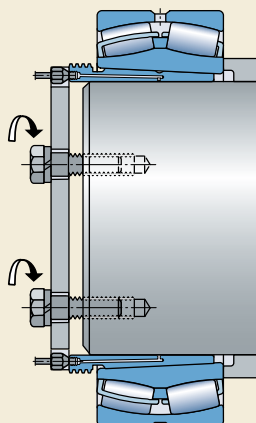

Mounting and dismounting

Measuring clearance reduction with a feeler gauge

The method using feeler gauges for measuring the radial internal clearance before and after mounting bearings is applicable for medium and large-sized spherical and toroidal roller bearings. The clearance should preferably be measured between the outer ring and an unloaded roller (→ **fig. 16**).

Measuring the lock nut tightening angle

Measuring the lock nut tightening angle is a proven method to determine the correct degree of interference in small to medium-sized bearings on tapered seatings (→ **fig. 17**). Guideline values for the tightening angle α have been established, providing accurate positioning of the bearing on its tapered seating.

Measuring the axial drive-up

Mounting bearings with a tapered bore can be done by measuring the axial drive-up of the inner ring on its seating. Guideline values for the required axial drive-up are given in the text preceding the relevant product table sections.

However, a more suitable method is the “SKF Drive-up Method”. This mounting method provides a reliable and easy way to determine the degree of interference. The correct fit is achieved by controlling the axial displacement of the bearing from a predetermined position. The method incorporates the use of an SKF hydraulic nut fitted with a dial indicator, and a specially calibrated digital gauge mounted on a selected pump (→ **fig. 18**). Determined values of the requisite oil pressure and the axial displacement for the individual bearings provide accurate positioning of the bearings. These values can be found

- in the handbook “SKF Drive-up Method” on CD-ROM,
- in the “SKF Interactive Engineering Catalogue” on CD-ROM or online at www.skf.com or
- online at www.skf.com/mount.

Fig. 16

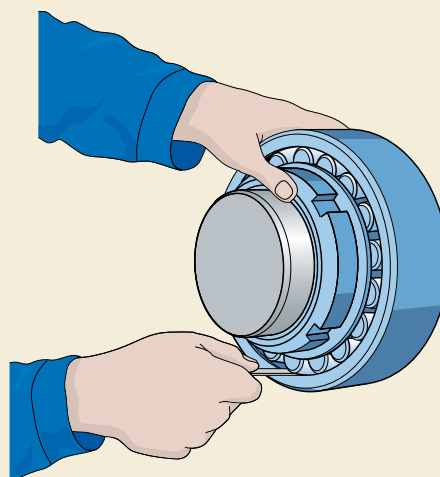

Fig. 17

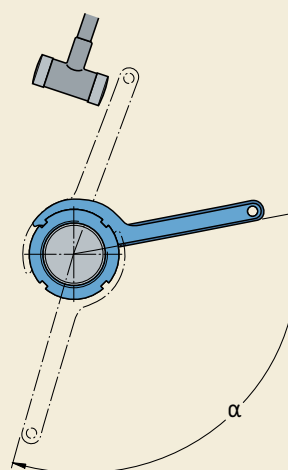
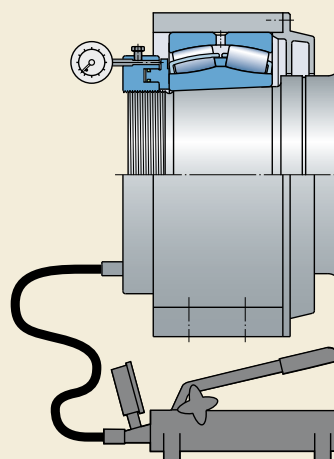

Fig. 18



Measuring the inner ring expansion

Measuring inner ring expansion is a simple and very accurate method to determine the correct position of large-size spherical and toroidal roller bearings on their seatings. For this kind of measurement the SensorMount® is available, using a sensor, integrated with the bearing inner ring, a dedicated hand-held indicator and common hydraulic mounting tools (→ **fig. 19**). Aspects such as bearing size, shaft smoothness, material or design – solid or hollow – do not need to be considered.

Test running

After mounting a bearing, the prescribed lubricant is applied and a test run made so that noise and bearing temperature can be checked.

The test run should be carried out under partial load and – where there is a wide speed range – at slow or moderate speed. Under no circumstances should a rolling bearing be allowed to start up unloaded and accelerated to high speed, as there is a danger that the rolling elements would slide on the raceways and damage them, or that the cage would be subjected to inadmissible stresses. Reference should be made to the section “Minimum load” in the text preceding the relevant product table sections.

Any noise or vibration can be checked using an SKF electronic stethoscope. Normally, bearings produce an even “purring” noise. Whistling or screeching indicates inadequate lubrication. An uneven rumbling or hammering is due in most cases to the presence of contaminants in

the bearing or to bearing damage caused during mounting.

An increase in bearing temperature immediately after start up is normal. For example, in the case of grease lubrication, the temperature will not drop until the grease has been evenly distributed in the bearing arrangement, after which an equilibrium temperature will be reached. Unusually high temperatures or constant peaking indicates that there is too much lubricant in the arrangement or that the bearing is radially or axially distorted. Other causes are that the associated components have not been correctly made or mounted, or that the seals have excessive friction.

During the test run, or immediately afterwards, the seals should be checked to see that they perform correctly and any lubrication equipment as well as the oil level of an oil bath should be checked. It may be necessary to sample the lubricant to determine whether the bearing arrangement is contaminated or components of the arrangement have become worn.

Fig. 19

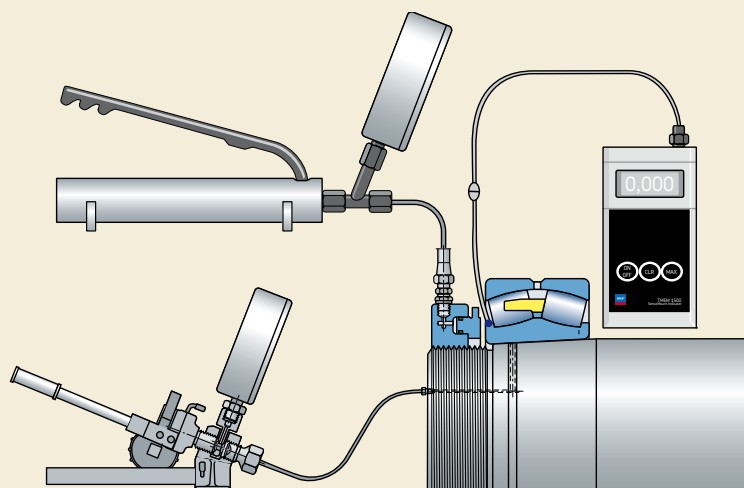

Dismounting

If bearings are to be used again after removal, the force used to dismount them must never be applied through the rolling elements.

With separable bearings, the ring with the rolling element and cage assembly can be removed independently of the other ring. With non-separable bearings, the ring having the looser fit should be withdrawn from its seating first. To dismount a bearing having an interference fit, the tools described in the following section may be used, the choice of tools will depend on bearing type, size and fit.

Dismounting bearings with a cylindrical bore

Cold dismantling

Small bearings may be removed from their seatings by applying light hammer blows via a suitable drift to the ring face, or preferably by using a puller. The claws of the puller should be placed around the side face of the ring to be removed, or an adjacent component (→ **fig. 20**), e.g. a labyrinth ring etc. Dismounting is made easier if

- provision is made for slots in the shaft and/or housing shoulders to take the claws of the puller, or
- tapped holes are provided in the housing shoulders to take withdrawal screws (→ **fig. 21**).

Larger bearings mounted with an interference fit generally require greater force to remove them, particularly if, after a long period of service, fretting corrosion has occurred. Use of the oil injection method considerably facilitates dismantling in such cases. This presupposes that the necessary oil supply ducts and distributor grooves have been designed into the arrangement (→ **fig. 22**).

Hot dismantling

Special induction heaters have been developed to dismount the inner rings of cylindrical roller bearings having no flanges or only one flange. They heat the inner ring rapidly without any appreciable heating of the shaft, so that the expanded inner ring can be removed easily. These electrical induction heaters (→ **fig. 23**)

Fig. 20

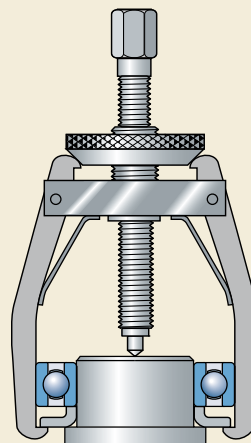

Fig. 21

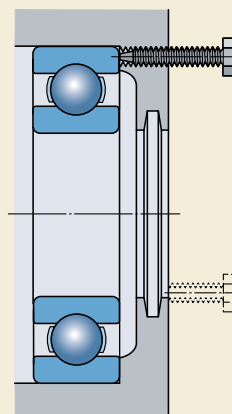

Fig. 22

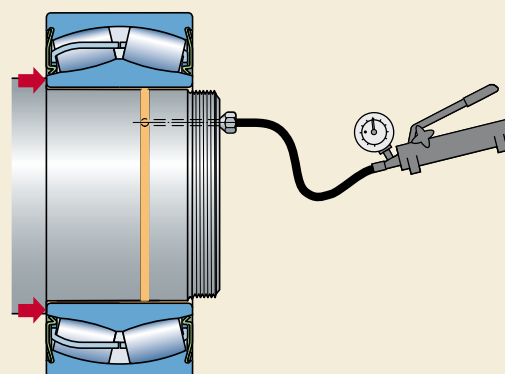
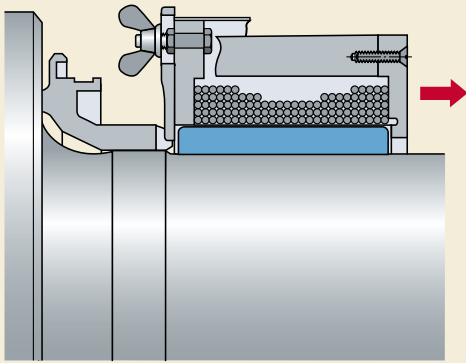

Fig. 23



have one or more coils energized by alternating current. It is necessary to demagnetize the inner rings after heating and removal. The use of electric withdrawal tools becomes economic when bearings of the same size are frequently mounted and dismantled.

When flangeless inner rings of cylindrical roller bearings, or those with only one flange, which have not to be removed frequently, or if larger sizes of inner rings (up to approximately 400 mm bore diameter) have to be dismantled, it is less costly and also easier to use a so-called thermo-withdrawal ring also referred to as a heating ring. This is a slotted ring, generally of light alloy, with handles (→ **fig. 24**).

The above-mentioned heaters and heating rings are available from SKF. Additional information can be found in the section “Maintenance and lubrication products”, starting on **page 1069**.

Fig. 24

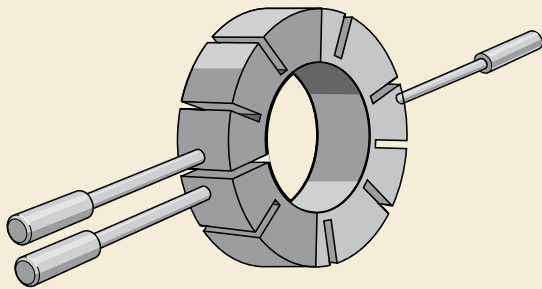

Mounting and dismounting

Dismounting bearings with a tapered bore

Dismounting bearing on a tapered journal

Small and medium-sized bearings on a tapered journal can be dismounted using conventional pullers, which engage the inner ring (→ **fig. 25**). Preferably a self-centring puller should be used to avoid damage to the bearing seating. Bearings on tapered seatings normally loosen very quickly. Therefore, it is necessary to provide a stop of some kind, a lock nut for example, to prevent the bearing from being completely withdrawn from the shaft.

The dismounting of large bearings from tapered journals is greatly eased if the oil injection method is employed. After injecting pressurised oil between the mating surfaces, the bearing will separate suddenly from its seating. A stop must therefore be provided, for example, a shaft nut or end plate, to limit the axial movement of the bearing to somewhat more than the drive-up distance (→ **fig. 26**).

Fig. 25

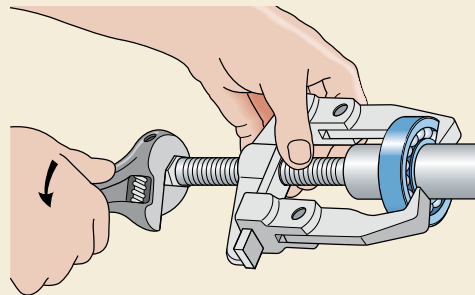

Fig. 26

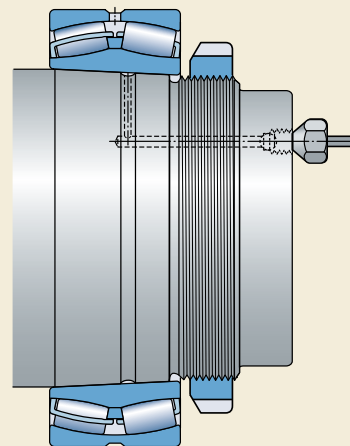
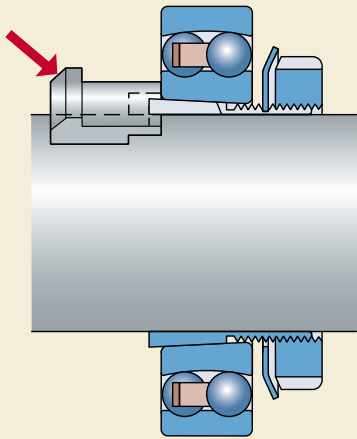

Fig. 27



Dismounting bearing on an adapter sleeve
 Small and medium-sized bearings on an adapter sleeve and smooth shafts can be dismounted by hammer blows directed to a drift (→ fig. 27) until the bearing becomes free. But first the sleeve nut has to be loosened a few turns.

Small and medium-sized bearings on an adapter sleeve and stepped shafts against a support ring can be dismounted by using a dolly abutting the sleeve nut, which has been released by a few turns (→ fig. 28).

Dismounting large bearings from an adapter sleeve with a hydraulic nut has proved easy to do. To use this technique however, the bearing must be mounted against a support ring (→ fig. 29). If the sleeves are provided with oil supply ducts and distributor grooves the dismounting becomes easier because the oil injection method can be employed.

Fig. 28

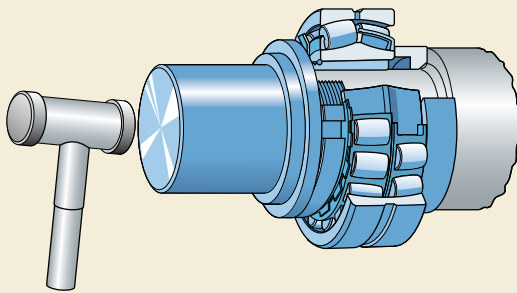

Dismounting bearing on a withdrawal sleeve
 When dismounting bearings on withdrawal sleeves, the axial locking device – a locking nut, end cover etc. – has to be removed.

Small and medium-sized bearings can be dismounted using a lock nut and a hook or impact spanner to free the bearing (→ fig. 30).

Fig. 29

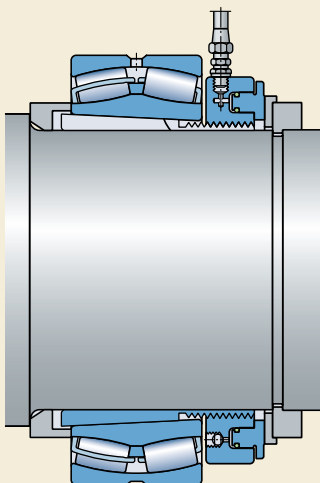
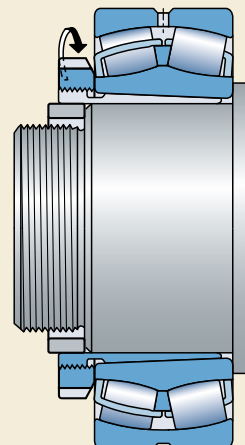

Fig. 30



Mounting and dismounting

The preferred means of dismounting large bearings is by using a hydraulic nut. If the threaded section of the sleeve protrudes beyond the shaft end or shaft shoulder, a support ring having the greatest possible wall thickness should be inserted in the sleeve bore to prevent distortion and damage to the thread when the hydraulic pressure is applied. SKF recommends providing a stop behind the hydraulic nut, e.g. through an end plate at the shaft end (→ **fig. 31**). The use of a stop prevents the withdrawal sleeve together with the hydraulic nut from being completely withdrawn from the shaft if the sleeve would separate suddenly from its seating.

Withdrawal sleeves for large bearings are generally provided with distributor ducts and grooves for the oil injection method to save considerable time when mounting as well as dismounting large bearings (→ **fig. 32**).

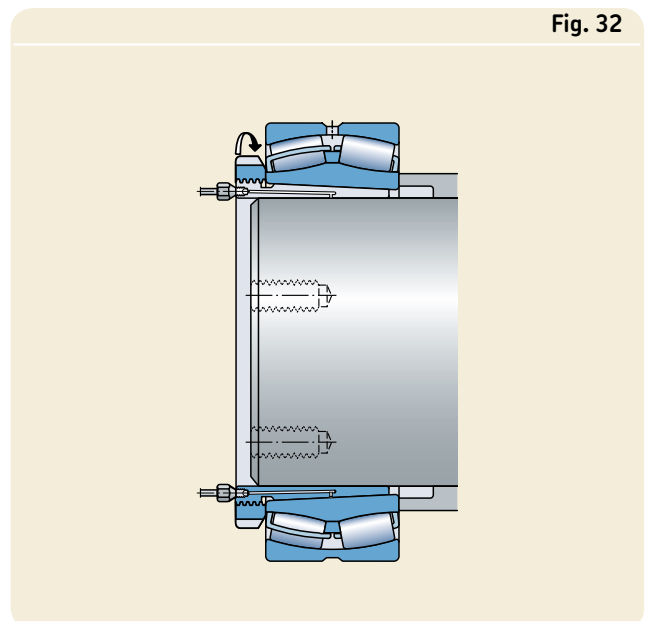
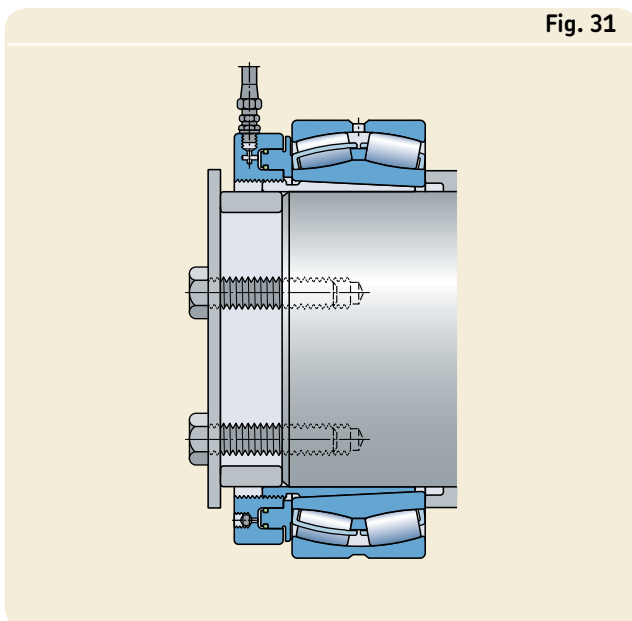

Bearing storage

Bearings can be stored in their original packaging for many years, provided that the relative humidity in the storeroom does not exceed 60 % and there are no great fluctuations in temperature. The storeroom should also be free of vibrations and shaking.

With sealed or shielded bearings it may be found that the lubricating properties of the grease with which they are filled may have deteriorated if the bearings have been stored for a long time. Bearings that are not stored in their original packaging should be well protected against corrosion and contamination.

Large rolling bearings should only be stored lying down, and preferably with support for the whole extent of the side faces of the rings. If kept in a standing position, the weight of the rings and rolling elements can give rise to permanent deformation because the rings are relatively thin-walled.

Inspection and cleaning

As with all other important machine components, ball and roller bearings must be frequently cleaned and examined. The intervals between such examinations depend entirely on the operating conditions.

If it is possible to ascertain the condition of the bearing during service, e.g. by listening to the sound of the bearing when it is running and measuring the temperature or examining the lubricant, then it is usually found sufficient if the bearings (rings, cage and rolling elements) and other parts of the bearing arrangement are thoroughly cleaned and inspected annually. Where the load is heavy, the frequency of inspection must be increased, e.g. rolling mill bearings are often inspected when the rolls are changed.

After the bearing components have been cleaned with a suitable solvent (white spirit, paraffin etc.) they should be oiled or greased immediately to prevent corrosion. This is particularly important for bearings in machines that are left to stand for considerable periods.





Reliability and services

An integrated platform	276
Decision support.....	276
Condition monitoring	276
Tools and lubricants	276
Component innovations	276
The Asset Efficiency Optimization™ concept.....	276
SKF technology and service solutions.....	277
Assessment.....	277
Maintenance strategy.....	278
Maintenance engineering	278
Supply process.....	278
Proactive reliability maintenance	278
Machine maintenance.....	278
Machine Improvement.....	278
Training	278
Integrated Maintenance Solutions	278
@ptitude® Industrial Decision Support System.....	279
Condition monitoring products	280
Microlog® family of data collectors	280
MARLIN® family of data managers.....	280
Vibration Pen ^{plus}	281
Inspector 400 ultrasonic probe	281
Infrared temperature probe.....	281
Machine condition transmitter, online monitoring units	282
Vibration sensors, eddy probes	282
Wireless sensors.....	282
Machinery protection systems.....	283
SKFmachine Operating Deflection Shape/Modal Analysis Software	283
SKF Machine Analyst™	283

Reliability and services

SKF has been a leader and innovator in bearing technology since 1907. The evolution of SKF expertise in machine reliability stems from the very nature of bearings and their applications. SKF's understanding of a bearing's performance in an application requires an equally extensive knowledge of the machines and the processes. The thorough understanding of machine components, systems and related processes, enables SKF to create and provide realistic solutions for optimum machine and process reliability and productivity.

Close working partnerships with customers worldwide has provided SKF with an extensive knowledge of applications in virtually every industry. As a result, SKF has learned to apply the most relevant of today's emerging technologies to industry-specific applications.

Through SKF Reliability Systems SKF provides a single source for a complete productivity solution. The goal is to help customers reduce total machine related costs, enhance productivity and strengthen profitability. Whatever the requirements SKF Reliability Systems offers the knowledge, services and products needed to achieve specific business goals.

An integrated platform

SKF's range of products and services provides the solutions that will ultimately lead to increased bottom line profitability. The focus on technology and seamless interface with plantwide systems supports four key areas.

Decision support

SKF can assist customers in retention, storage and utilization of crucial information with its @ptitude industrial decision support software (→ **page 279**).

Condition monitoring

As a leading supplier of condition monitoring products, SKF offers a complete range – from hand-held data collectors/analysers to online surveillance and machine protection systems. These products provide interface with condition monitoring analysis software and other plantwide systems and are listed starting on **page 280**.

Tools and lubricants

SKF has developed a range of tools and lubricants to provide safe and damage-free machine maintenance. Brief information on these products is provided in the section "Maintenance and lubrication products", starting on **page 1069**.

Component innovations

Component innovations are needed to achieve productivity goals that were never intended by original equipment manufacturers. SKF has developed bearing products designed to run faster, longer and cooler without maintenance in many difficult applications. A selection of such products is listed in the sections "Engineering products", starting on **page 893**, and "Mechatronics", starting on **page 955**.

The Asset Efficiency Optimization concept

The Asset Efficiency Optimization™ (AEO) concept from SKF picks up where most plant asset management programmes typically stop. Using this concept enables a plant to produce the same amount for less cost, or to produce more for the same costs. It is a system for organizing and applying assets – from personnel to machinery – bringing together knowledge and technology to achieve the greatest return on investment.

By applying the power of SKF's technology and service solutions, you can benefit from a programme that assists in achieving your organization's overall business objectives. These include reduced costs, greater productivity, better utilization of resources, and as a result, increased bottom line profitability (→ **diagram 1**).

SKF technology and service solutions

The following summarizes the most important services and products that SKF Reliability Systems offers to provide solutions to the real-life application conditions. For detailed information on the SKF Reliability Systems program please refer to publication 5160 “The Guide to Asset Efficiency Optimization™ for Improved Profitability” or visit www.skf.com/reliability for the latest information on strategies and services.

Assessment

An assessment can include one or all of the following areas:

- Determination of current situation.
- Maintenance.
- Supply and stores processes.
- Predictive maintenance.

Diagram 1

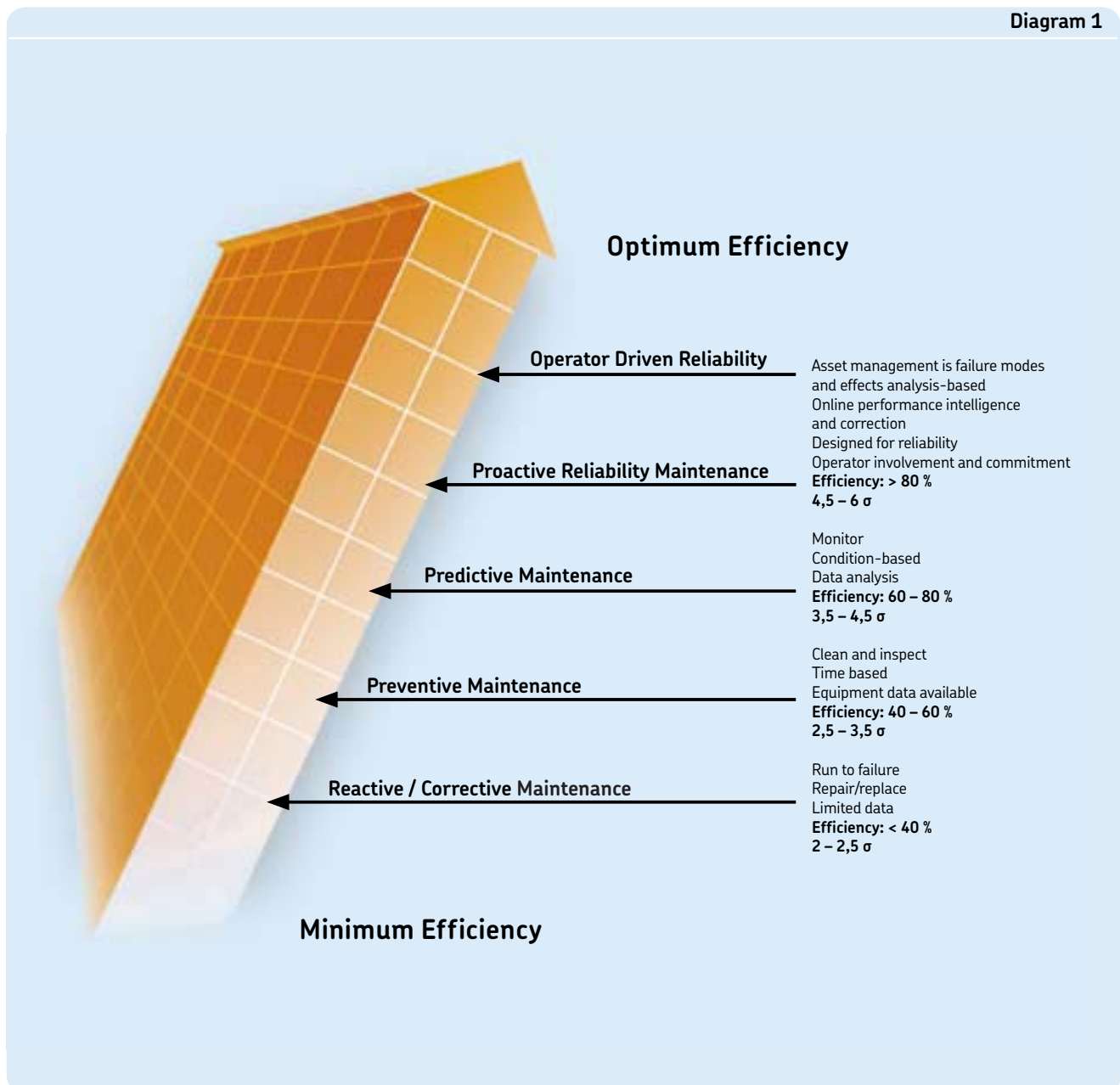

Reliability and services

Maintenance strategy

SKF can help to establish a comprehensive maintenance strategy, designed to make sure that productivity as well as safety and integrity issues receive the attention they require.

Diagram 1 on **page 277** illustrates the range and ranking of maintenance practices.

The latest and innovative approach to maintenance is called Operator Driven Reliability (ODR). This maintenance concept is simply a framework for organizing the activities of plant operations personnel in concert with a company's reliability maintenance practices. SKF has the knowledge and equipment to initiate and support this approach.

Maintenance engineering

Maintenance engineering is putting the strategy to work and includes for example the implementation of a "Computerized Maintenance Management System" (CMMS) with all the data and process information needed to achieve maintenance strategy goals.

Supply process

This service is an integral part of increasing profitability by reducing transaction costs, releasing capital tied up in spare inventory and making sure that the spares are available when needed.

Proactive Reliability Maintenance

Following the SKF Proactive Reliability Maintenance (PRM) process helps to provide best return on plant assets. It addresses failures and implements the processes necessary to prevent recurrence. The PRM process is based on four key steps:

- Predictive maintenance, a multi-faceted process that uses sophisticated technology systems to gather comprehensive intelligence on machine conditions and production processes.
- Diagnostics and Root Cause Analysis (RCA) to identify problems and necessary actions, such as machine alignment, balancing etc.
- Key performance indicators are performance improvement targets, established jointly between SKF and the customer.

- Periodic operational reviews between SKF and the plant management to analyze performance.

Machine maintenance

SKF Reliability Systems has developed its most comprehensive service programme for rotating equipment to drive machine maintenance in the most cost effective ways. This programme includes products and services such as

- machine alignment
- precision balancing
- lubrication management
- bearing damage analysis
- technology advice and machine upgrades
- bearing installation.

Machine improvement

To remain competitive, plants must keep pace with new machine technologies. SKF can help to keep pace – without the need to invest in new machines. Recommendations can include one, or a combination of actions:

- Upgrade, rebuild and re-design.
- Design engineering.
- Refurbishment of bearings.
- Repair and upgrade machine tool spindles.
- Instrument/equipment calibrations.

Training

SKF Reliability Services offers comprehensive machine reliability and asset management training – from the shop floor to the highest level of management.

Integrated Maintenance Solutions

An Integrated Maintenance Solution (IMS) agreement brings together all areas of expertise offered by SKF, establishing a continuous process of maintenance monitoring, analysis and improvement. It provides a planned skills transfer programme for maintenance and operations personnel, and technology upgrades where required.

With an IMS agreement, SKF Reliability Systems will manage every key component of a machine asset management strategy, provid-

ing a total system for improving efficiency. Each agreement is customized to specific business needs. The user can choose which areas need to be included, based on internal resources and current supplier contracts. With an IMS contract, SKF shares some of the risk as well as the savings, while the user receives agreed-upon financial returns with little to no capital investment.

@ptitude® Industrial Decision Support System

The @ptitude Industrial Decision Support System from SKF is a knowledge management system that incorporates today's most advanced technologies to integrate data from multiple sources into an easy to use reliability maintenance application. It enhances the user team ability to make the right decision at the right time, providing a structured approach to capturing and applying knowledge. A key element of the @ptitude system is its online, web-enabled asset management knowledge bank. @ptitudeXchange subscribers have access to articles, technical handbooks, white papers, best practices and benchmarking information, interactive decision-support programs and an information network for expert advice and services.

For additional information, please visit www.apitudexchange.com.



Condition monitoring products

At the core of the SKF product range are the vibration detection, analysis and diagnostic products, which enable process monitoring as an added benefit. Some of those products are shown below. More information about SKF condition monitoring products can be found online at www.skf.com.

Microlog® family of data collectors

The SKF family of Microlog data collector/analysers is designed so that users can easily establish a comprehensive periodic condition monitoring programme. As a diagnostic tool, the Microlog is unequalled in its class. Embedded intelligence provides step-by-step instructions for performing critical analysis functions like basic and advanced balancing, cyclic analysis, run-up/coast-down, bump test, tracking filter or motor current analysis. The frequency analysis module enables overlay defect frequencies on collected spectra to detect bearing defects, gear mesh, misalignment, unbalance or looseness problems.

MARLIN® family of data managers

The MARLIN data management system is designed to be the frontline tool for operators, building the communications/technology bridge between operations, maintenance, engineering and plant management. This rugged high performance data collector provides a simple, convenient and portable way to collect and store machine vibration, process, and inspection data for quick downloading and analysis.



Vibration Pen ^{plus}

The Vibration Pen ^{plus} offers users a way to begin a cost-effective condition monitoring program, or to expand the responsibility for machine reliability to operators throughout the plant. A multi-parameter vibration monitoring tool, the Vibration Pen ^{plus} operates with the press of a button, measuring vibration according to ISO standards and utilizing acceleration enveloping technology to identify a range of bearing, gear mesh and other machinery problems.

Inspector 400 ultrasonic probe

The Inspector 400 ultrasonic probe senses high frequency sounds produced by leaks, electrical discharges and equipment as it operates. It electronically translates these signals using a heterodyning process, making them audible through a headset and “visible” as increments on a meter. This enables maintenance personnel to detect pressure and vacuum leaks, arcing, tracking and corona in electric apparatus or test bearings, pumps, motors, compressors etc.

Infrared temperature probe

This laser sighted non-contact thermometer senses the temperature of an object with an infrared detector, enabling maintenance personnel to take temperature readings in locations that might otherwise be difficult to access.



Reliability and services

Machine condition transmitter, online monitoring units

SKF machine condition transmitters provide vital information about bearing performance and overall machine condition. This information can be used to make sure that essential production equipment is kept running. This cost effective system offers two adjustable warning levels (alert and alarm) via two independent set points with LED alarm indicators and output relay contacts.

Online monitoring units provide around-the-clock automated data collection and a powerful array of analysis tools to optimize condition monitoring efforts. If a machine starts to develop a problem, the system helps to detect, analyse and track the defect so that maintenance costs are minimized. A “live” mode feature enables detailed online analysis, while event logs provide a history of events that may have occurred while the system was unattended.



Vibration sensors, eddy probes

SKF's in-depth bearing, machinery, monitoring and signal processing knowledge was included in the development of the CMSS2100 and CMSS2200 vibration sensor series. These single units can be used instead of the wide range of accelerometers typically needed to meet a variety of conditions.

In addition to a full line of vibration sensors SKF also offers eddy probe systems for the measurement of relative motion in sleeve bearing machines.



Wireless sensors

Wireless sensors developed by SKF are excellent for online monitoring of machine condition in rotating equipment. Since they are wireless, difficult access is no problem and data can be collected safely from a distance. At the heart of the system is an SKF vibration sensor that is connected to a battery-powered unit transmitting the signals wirelessly to a base station. The wireless system is available as a stand-alone package or as a complement to the SKF cable based online system.



Machinery protection systems

DYMAC, an SKF Group company, offers total system integration by bringing advanced condition monitoring and protection systems into a plant-wide control platform. The end result is not only improved profitability, but also a better and safer environment. For example, the VM600 Machinery Monitoring System, a digital, modular, scalable hardware and software solution for Plant Usage Optimization provides integrated machinery protection, condition and advanced performance monitoring from a single source.

For more information, please visit www.skf.com.



SKFmachine Operating Deflection Shape/Modal Analysis Software

SKFmachine ODS and SKFmachine SHAPE are easy to use, window-based software programs to observe, analyse and document the dynamic behaviour of machinery. They help to easily identify and correct problems related to structural weakness and resonances in machinery.

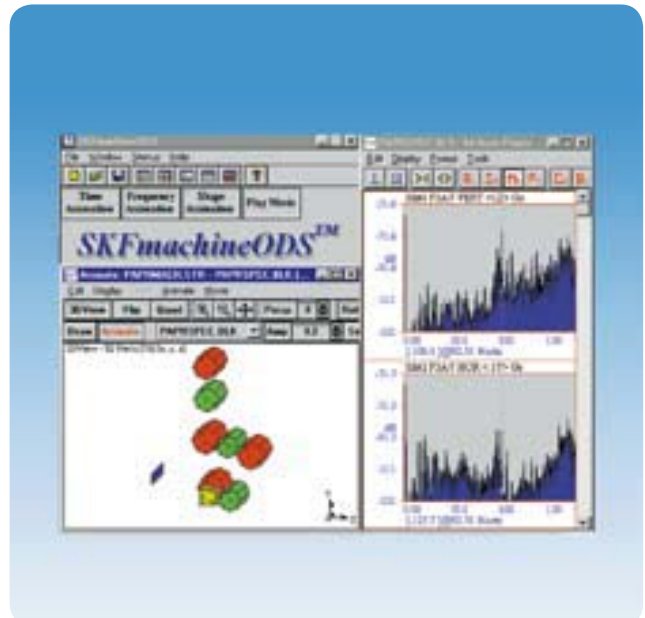

SKF Machine Analyst™

SKF Machine Analyst is the core component in a suite of software applications that provide a comprehensive reliability solution for process and manufacturing plants. It is the follow-up software solution of the successful PRISM⁴ suite. Written from the ground up using Component Object Model (COM) architecture, SKF Machine Analyst can be easily and effectively integrated with third party plug-ins, as well as systems such as computerized maintenance management systems, enterprise resource planning and others. Several versions are available, e.g. for online monitoring systems or to work with the MARLIN data management system. SKF Machine Analyst takes full advantage of the Microsoft Windows[®] functionality and features including multi-tasking, context-sensitive help, right-click functionality and the Windows Explorer™ graphical user interface.

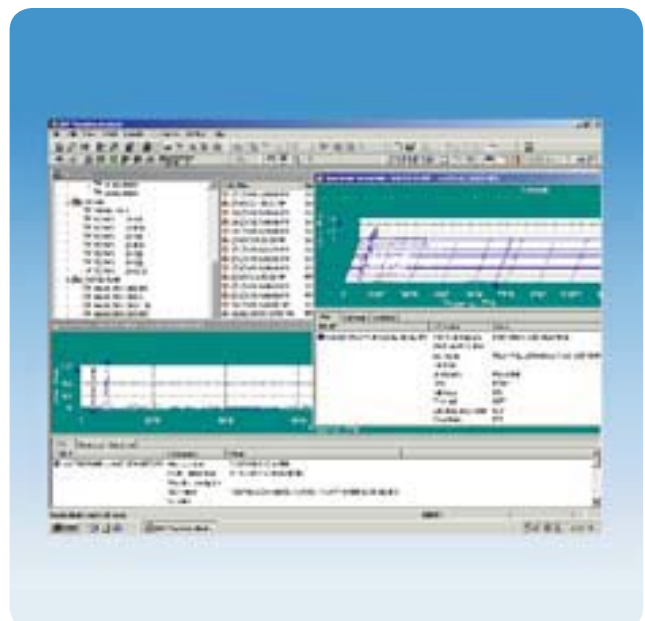



Product data

Deep groove ball bearings.....	287
Angular contact ball bearings.....	405
Self-aligning ball bearings.....	469
Cylindrical roller bearings	503
Taper roller bearings	601
Spherical roller bearings.....	695
CARB® toroidal roller bearings.....	779
Thrust ball bearings	837
Cylindrical roller thrust bearings	863
Spherical roller thrust bearings.....	877
Engineering products	893
Mechatronics	955
Bearing accessories.....	973
Bearing housings	1031
Maintenance and lubrication products	1069
Other SKF products	1081
Product index.....	1121

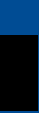



Deep groove ball bearings

Single row deep groove ball bearings 289



Single row deep groove ball bearings with filling slots .. 361

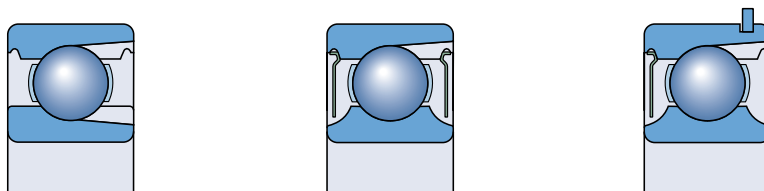

Stainless steel deep groove ball bearings 373

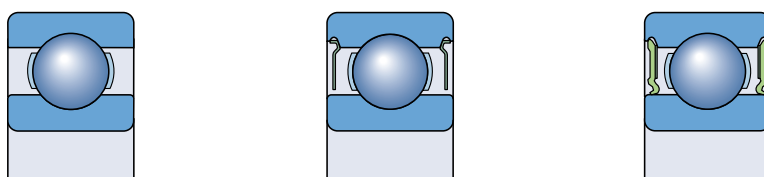

Double row deep groove ball bearings..... 391

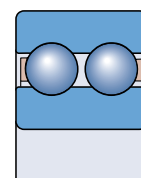

Single row cam rollers..... 399

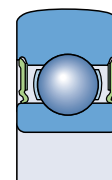



Single row deep groove ball bearings

Designs	290
Basic design bearings	290
Sealed bearings	290
ICOS™ oil sealed bearing units.....	293
Bearings with a snap ring groove	294
Matched bearing pairs.....	295
SKF Explorer class bearings	295
Bearing data – general	296
Dimensions.....	296
Tolerances.....	296
Internal clearance.....	296
Misalignment	296
Cages.....	298
Minimum load	298
Axial load carrying capacity	299
Equivalent dynamic bearing load	299
Equivalent static bearing load	299
Supplementary designations.....	300
Product tables	302
Single row deep groove ball bearings	302
Sealed single row deep groove ball bearings	324
ICOS™ oil sealed bearing units	348
Single row deep groove ball bearings with snap ring groove	350
Single row deep groove ball bearings with snap ring groove and shields	356

Single row deep groove ball bearings

Single row deep groove ball bearings are particularly versatile. They are simple in design, non-separable, suitable for high and even very high speeds and are robust in operation, requiring little maintenance. Deep raceway grooves and the close conformity between the raceway grooves and the balls enable deep groove ball bearings to accommodate axial loads in both directions, in addition to radial loads, even at high speeds.

Single row deep groove ball bearings are the most widely used bearing type. Consequently, they are available from SKF in many executions and sizes

- open basic design bearings
- sealed bearings
- ICOS™ oil sealed bearing units
- bearings with snap ring groove, with or without snap ring.

Other deep groove ball bearings for special applications, shown in the sections “Engineering products” and “Mechatronics”, include

- hybrid bearings (→ [page 895](#))
- insulated bearings (→ [page 911](#))
- high temperature bearings (→ [page 921](#))
- bearings with Solid Oil (→ [page 949](#))
- sensorized bearings (→ [page 957](#)).

The SKF product range also includes inch-size bearings and bearings with a tapered bore. These variants are not included in this General

Catalogue. Information will be provided on request.

Designs

Basic design bearings

Basic design SKF single row deep groove ball bearings (→ [fig. 1](#)) are open (unsealed). For manufacturing reasons, those sizes of open bearings that are also produced in sealed or shielded versions may have seal recesses in the outer ring.

Sealed bearings

The most popular sizes of deep groove ball bearings are also produced in sealed versions with shields or contact seals on one or both sides. Details about the suitability of the different seals for various operating conditions can be found in [table 1](#). Sealed bearings in the 622, 623 and 630 wide series are particularly suitable for long maintenance-free service. In addition, ICOS bearing units with integrated radial shaft seals are available for higher sealing requirements.

The bearings with shields or seals on both sides are lubricated for life and are maintenance-free. They should not be washed nor heated to temperatures above 80 °C. Depending on the series and size, deep groove ball bearings are supplied charged with different standard greases (→ [table 2](#)).

The standard grease is not identified in the bearing designation. The quantity of grease fills some 25 to 35 % of the free space in the bearing. To special order, bearings with other grease filling grades are available.

Also on request, bearings with special greases can be supplied, such as

- high temperature grease GJN (bearings with $D \leq 62$ mm)
- high temperature grease GXN
- wide temperature range grease GWB
- wide temperature range and silent running grease LHT23 (for bearings where it is not standard)
- low temperature grease LT20.

The technical specifications of the various greases are listed in [table 3](#).

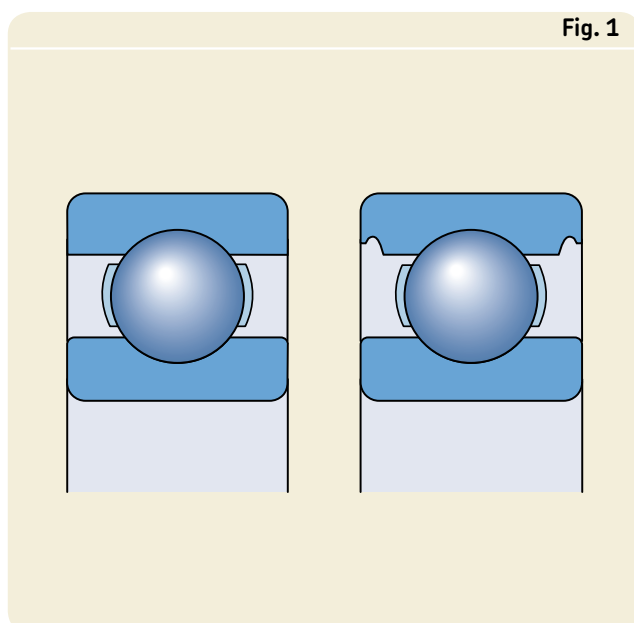

Table 1

Seal selection guidelines					
Requirement	Shields Z	Low-friction seals		Contact seals	
		RSL	RZ	RSH	RS1
Low friction	+++	++	+++	0	0
High speeds	+++	+++	+++	0	0
Grease retention	0	+++	+	+++	++
Dust exclusion	0	++	+	+++	+++
Water exclusion					
static	-	0	-	+++	++
dynamic	-	0	-	+	+
high pressure	-	0	-	+++	0

Symbols: +++ excellent ++ very good + good 0 fair – not recommended

Table 2

SKF standard greases for sealed deep groove ball bearings of carbon chromium steel				
Bearings of Diameter Series	SKF standard greases in bearings with outside diameter			
	D ≤ 30 mm d < 10 mm	d ≥ 10 mm	30 < D ≤ 62 mm	D > 62 mm
8, 9	LHT23	LT10	MT47	MT33
0, 1, 2, 3	MT47	MT 47	MT47	MT33

Table 3

Technical specifications of SKF standard and special greases for sealed deep groove ball bearings of carbon chromium steel								
Technical specification	LHT23	LT10	MT47	MT33	GJN	GXN	GWB	LT20
Thickener	Lithium soap	Lithium soap	Lithium soap	Lithium soap	Polyurea soap	Polyurea soap	Polyurea soap	Lithium soap
Base oil type	Ester oil	Diester oil	Mineral oil	Mineral oil	Mineral oil	Mineral oil	Ester oil	Diester oil
NLGI class	2	2	2	3	2	2	2–3	2
Temperature range, °C ¹⁾	–50 to +140	–50 to +90	–30 to +110	–30 to +120	–30 to +150	–40 to +150	–40 to +160	–55 to +110
Base oil viscosity, mm ² /s								
at 40 °C	26	12	70	98	115	96	70	15
at 100 °C	5,1	3,3	7,3	9,4	12,2	10,5	9,4	3,7

¹⁾For safe operating temperature, → section “Temperature range – the SKF traffic light concept”, starting on page 232

Single row deep groove ball bearings

Bearings with shields

Bearings with shields, designation suffix Z or 2Z, are produced in one of two designs, depending on the bearing series and size (→ **fig. 2**). The shields are made of sheet steel and normally have a cylindrical extension in the shield bore to form a long sealing gap with the inner ring shoulder (**a**). Some shields do not have the extension (**b**).

Shielded bearings are primarily intended for applications where the inner ring rotates. If the outer ring rotates, there is a risk that the grease will leak from the bearing at high speeds.

Bearings with low-friction seals

SKF deep groove ball bearings with low-friction seals, designation suffixes RSL, 2RSL or RZ, 2RZ, are manufactured in three designs depending on bearing series and size (→ **fig. 3**)

- bearings in the 60, 62 and 63 series up to 25 mm outside diameter are equipped with RSL seals to design (**a**)
- bearings in the 60, 62 and 63 series from 25 mm and up to and including 52 mm outside diameter are equipped with RSL seals to design (**b**)
- other bearings have RZ seals (**c**).

The seals form an extremely narrow gap with the cylindrical surface of the inner ring shoulder or recess profile and are practically non-contacting. Because of this, bearings fitted with low-friction seals can be operated at the same

high speeds as bearings with Z shields, but with improved seal performance.

The low-friction seals are made of oil and wear-resistant acrylonitrile-butadiene rubber (NBR) with a sheet steel reinforcement. The permissible operating temperature range for these seals is -40 to $+100$ °C and up to $+120$ °C for brief periods.

Bearings with contact seals

Bearings with contact seals, designation suffixes RSH, 2RSH or RS1, 2RS1, are manufactured in four designs depending on bearing series and size (→ **fig. 4**)

- bearings in the 60, 62, and 63 series up to 25 mm outside diameter are equipped with RSH seals to design (**a**)
- bearings in the 60, 62 and 63 series from 25 mm and up to and including 52 mm outside diameter are equipped with RSH seals to design (**b**)
- other bearings have RS1 seals, which seal against the cylindrical surface of the inner ring shoulder (**c**) indicated by dimension d_1 in the product table or against a recess in the inner ring side face (**d**) indicated by dimension d_2 in the product table.

The seals are inserted in recesses in the outer ring and provide good sealing at this position without deforming the outer ring. Standard seals are made of acrylonitrile-butadiene rubber (NBR) with a sheet steel reinforcement. The permissible operating temperature range

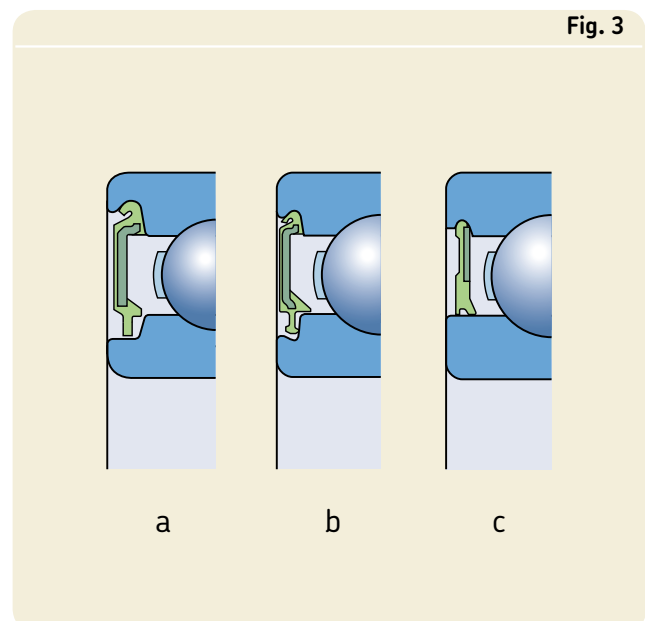
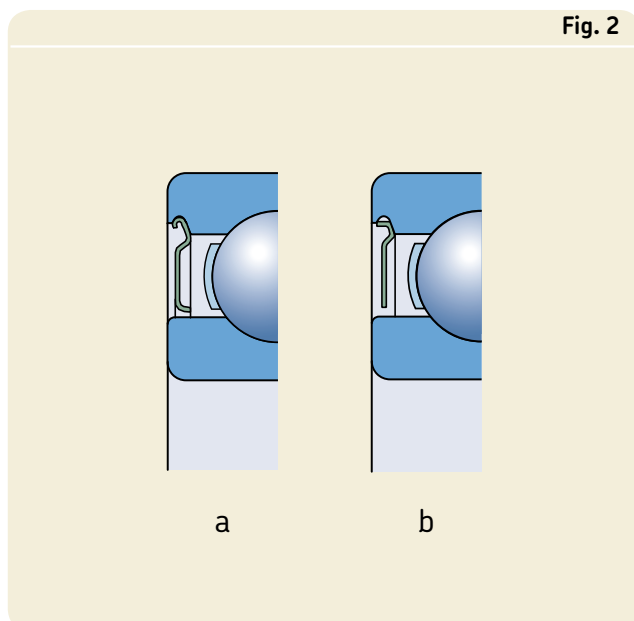
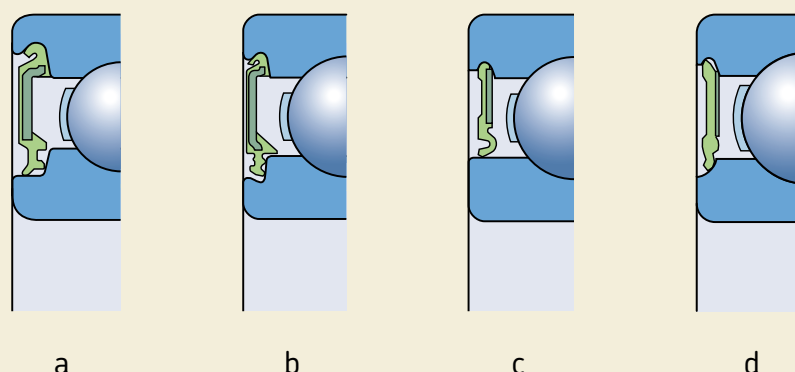

Fig. 4



for these seals is -40 to $+100$ °C and up to $+120$ °C for brief periods.

When sealed bearings are operated under certain extreme conditions, e.g. very high speeds or high temperatures, grease leakage may occur at the inner ring. For bearing arrangements where this would be detrimental, special design steps must be undertaken, please consult the SKF application engineering service.

ICOS™ oil sealed bearing units

ICOS oil sealed bearing units have been developed by SKF. The new concept aims at applications where sealing requirements exceed the capabilities of standard sealed bearings. An ICOS unit consists of a 62 series deep groove ball bearing and an integral CR radial shaft seal (→ fig. 5). These units need less space than common two-component arrangements; they simplify mounting, and avoid expensive machining of the shaft because the inner ring shoulder is an excellent counterface.

The CR radial shaft seal is made of acrylonitrile-butadiene rubber (NBR) and has a spring loaded wavelip. The permissible operating temperature range for the seal is -40 to $+100$ °C and up to $+120$ °C for brief periods.

The speed limits quoted in the product table are based on the permissible circumferential speed for the CR seal, which in this case is 14 m/s.

Fig. 5

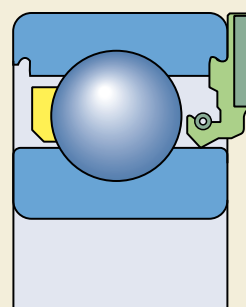

Single row deep groove ball bearings

Bearings with a snap ring groove

Deep groove ball bearings with a snap ring groove can simplify arrangement design as the bearings can be axially located in the housing by a snap (or retaining) ring (→ **fig. 6**). This saves space. Appropriate snap rings are shown in the product table with designation and dimensions and may be supplied separately or already mounted on the bearing.

SKF deep groove ball bearings with a snap ring groove (→ **fig. 7**) are supplied as

- open (unsealed) bearings, designation suffix N (**a**)
- open bearings with a snap ring, designation suffix NR (**b**)
- bearings with a Z shield at the opposite side and a snap ring, designation suffix ZNR (**c**)
- bearings with Z shields on both sides and a snap ring, designation suffix 2ZNR (**d**).

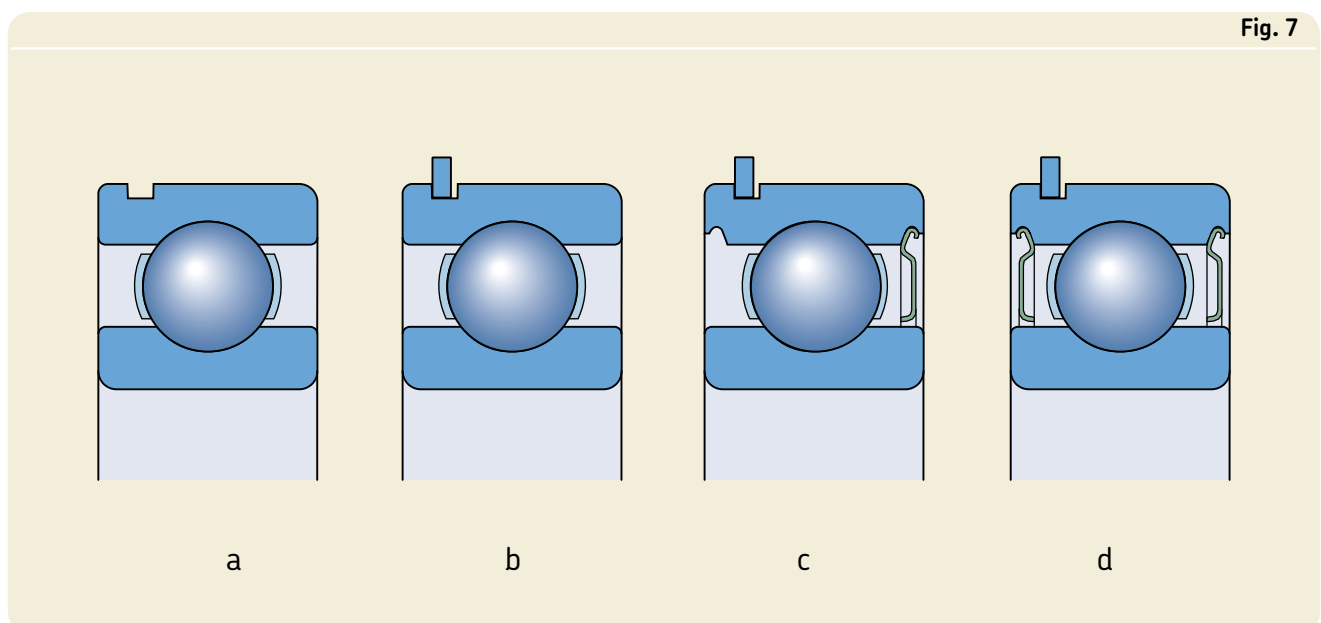
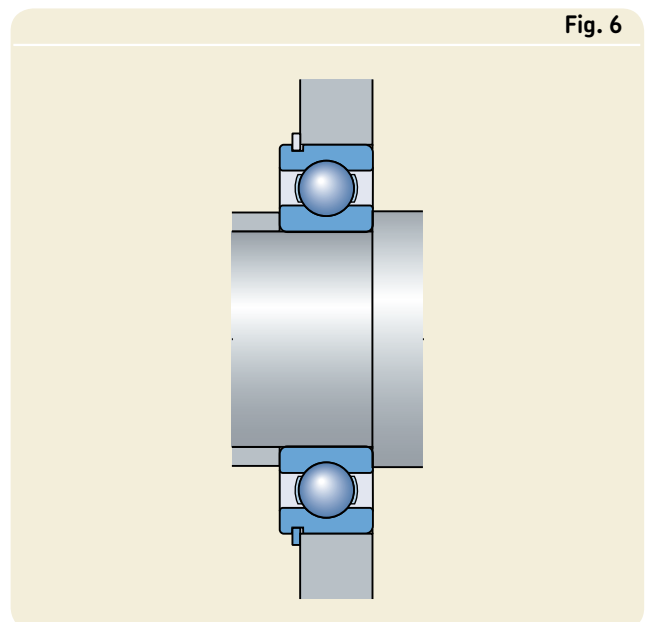

Matched bearing pairs

For bearing arrangements where the load carrying capacity of a single bearing is inadequate, or where the shaft has to be axially located in both directions with a given amount of axial clearance, SKF can supply matched pairs of single row deep groove ball bearings to order. Depending on the requirements the matched pairs can be supplied in tandem, back-to-back, or face-to-face arrangements (→ **fig. 8**). The bearings are matched in production so that, when mounted immediately adjacent to each other, the load will be evenly distributed between the bearings without having to use shims or similar devices.

Further information on matched bearing pairs can be found in the “SKF Interactive Engineering Catalogue” on CD-ROM or online at www.skf.com.

SKF Explorer class bearings

High performance SKF Explorer deep groove ball bearings are shown with an asterisk in the product tables. The higher performance of SKF Explorer deep groove ball bearings also includes quieter running. SKF Explorer bearings retain the designation of the earlier standard bearings, e.g. 6208. However, each bearing and its box are marked with the name “EXPLORER”.

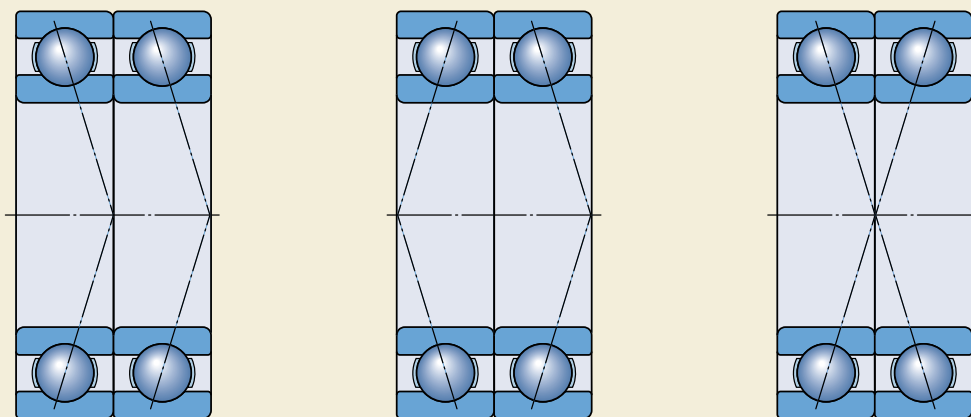

Fig. 8

Bearing data – general

Dimensions

The boundary dimensions of SKF single row deep groove ball bearings are in accordance with ISO 15:1998. Dimensions of the snap ring grooves and snap rings comply with ISO 464:1995.

Tolerances

SKF single row deep groove ball bearings are manufactured as standard to Normal tolerances.

SKF Explorer single row deep groove ball bearings are produced to higher precision than the ISO Normal tolerances. The dimensional accuracy corresponds to P6 tolerances, except the width tolerance, which is considerably tighter and reduced to

- 0/–60 µm for bearings with outside diameter up to 110 mm
- 0/–100 µm for larger bearings.

The running accuracy depends on the bearing size and corresponds to

- P5 tolerances for bearings up to 52 mm outside diameter
- P6 tolerances for bearings above 52 mm up to 110 mm outside diameter
- Normal tolerances for larger bearings.

For bearing arrangements where accuracy is a key operational factor some SKF single row deep groove ball bearings are also available with accuracy completely to P6 or P5 tolerance class specifications. The availability of these bearings should always be checked before ordering.

The tolerances are in accordance with ISO 492:2002 and can be found in **tables 3 to 5**, starting on **page 125**.

Internal clearance

SKF single row deep groove ball bearings are manufactured with Normal radial internal clearance as standard. Most of the bearings are also available with C3 radial internal clearance. Some bearings can also be supplied with a smaller C2 clearance or the much greater C4 or C5 clearances. In addition, deep groove ball bearings

are available with reduced or displaced internal clearance ranges. These special clearances may use reduced ranges of standard clearance classes or partitions of adjacent classes (→ designation suffix CN on **page 300**). Bearings with internal clearance not to standard can be supplied on request.

The values for radial internal clearance are provided in **table 4**. They are in accordance with ISO 5753:1991 and are valid for unmounted bearings under zero measuring load.

Misalignment

Single row deep groove ball bearings have only limited ability to accommodate misalignment. The permissible angular misalignment between the inner and outer rings, which will not produce inadmissibly high additional stresses in the bearing, depends on

- the radial internal clearance of the bearing in operation
- the bearing size
- the internal design
- the forces and moments acting on the bearing.

Because of the complex relationship between these factors, no generally applicable specific values can be given. However, depending on the various influences of the factors, the permissible angular misalignment lies between 2 and 10 minutes of arc. Any misalignment will result in increased bearing noise and reduced bearing service life.

Table 4

Radial internal clearance of deep groove ball bearings

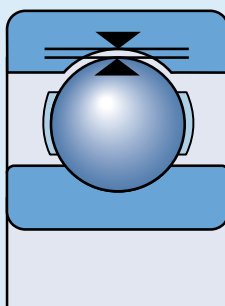

Bore diameter		Radial internal clearance									
d over	incl.	C2		Normal		C3		C4		C5	
		min	max	min	max	min	max	min	max	min	max
mm		µm									
6	6	0	7	2	13	8	23	–	–	–	–
	10	0	7	2	13	8	23	14	29	20	37
	18	0	9	3	18	11	25	18	33	25	45
18	24	0	10	5	20	13	28	20	36	28	48
	30	1	11	5	20	13	28	23	41	30	53
	40	1	11	6	20	15	33	28	46	40	64
40	50	1	11	6	23	18	36	30	51	45	73
	50	1	15	8	28	23	43	38	61	55	90
	65	1	15	10	30	25	51	46	71	65	105
80	100	1	18	12	36	30	58	53	84	75	120
	100	2	20	15	41	36	66	61	97	90	140
	120	2	23	18	48	41	81	71	114	105	160
140	160	2	23	18	53	46	91	81	130	120	180
	160	2	25	20	61	53	102	91	147	135	200
	180	2	30	25	71	63	117	107	163	150	230
200	225	4	32	28	82	73	132	120	187	175	255
	225	4	36	31	92	87	152	140	217	205	290
	250	4	39	36	97	97	162	152	237	255	320
280	315	8	45	42	110	110	180	175	260	260	360
	315	8	50	50	120	120	200	200	290	290	405
	355	8	60	60	140	140	230	230	330	330	460
400	450	10	70	70	160	160	260	260	370	370	520
	450	10	80	80	180	180	290	290	410	410	570
	500	20	90	90	200	200	320	320	460	460	630
560	630	20	100	100	220	220	350	350	510	510	700
	630	30	120	120	250	250	390	390	560	560	780
	710	30	130	130	280	280	440	440	620	620	860
800	900	30	150	150	310	310	490	490	690	690	960
	900	40	160	160	340	340	540	540	760	760	1 040
	1 000	40	170	170	370	370	590	590	840	840	1 120
1 120	1 250	40	180	180	400	400	640	640	910	910	1 220
	1 250	60	210	210	440	440	700	700	1 000	1 000	1 340
	1 400	60	230	230	480	480	770	770	1 100	1 100	1 470

Please refer to page 137 for the definition of radial internal clearance

Single row deep groove ball bearings

Cages

Depending on the bearing series, design and size, SKF single row deep groove ball bearings are fitted as standard with one of the following cages (→ **fig. 9**)

- a pressed ribbon-type steel cage, ball centred, no designation suffix (**a**)
- a pressed ribbon-type brass cage, ball centred, designation suffix Y
- a riveted pressed steel cage, ball centred, no designation suffix (**b**)
- a riveted pressed brass cage, ball centred, designation suffix Y
- a machined brass cage, ball centred, designation suffix M (**c**)
- a machined brass cage, outer ring centred, designation suffix MA
- an injection moulded snap-type cage of glass fibre reinforced polyamide 6,6, ball centred, designation suffix TN9 (**d**).

Bearings having a pressed steel cage in standard execution may also be available with a machined brass or injection moulded snap-type cage of polyamide 6,6. For higher operating temperatures, cages of polyamide 4,6 or polyetheretherketone (PEEK), designation suffix TNH, may be advantageous. Please check availability prior to ordering.

Note

Deep groove ball bearings with polyamide 6,6 cages can be operated at temperatures up to +120 °C. The lubricants generally used for roll-

ing bearings do not have a detrimental effect on cage properties, with the exception of a few synthetic oils and greases with a synthetic oil base and lubricants containing a high proportion of EP additives when used at high temperatures.

For bearing arrangements, which are to be operated at continuously high temperatures or under arduous conditions, SKF recommends using bearings with a pressed steel or a machined brass cage.

For detailed information about the temperature resistance and the applicability of cages, please refer to the section “Cage materials”, starting on **page 140**.

Minimum load

In order to provide satisfactory operation, deep groove ball bearings, like all ball and roller bearings, must always be subjected to a given minimum load, particularly if they are to operate at high speeds or are subjected to high accelerations or rapid changes in the direction of load. Under such conditions, the inertia forces of the balls and cage, and the friction in the lubricant, can have a detrimental effect on the rolling conditions in the bearing arrangement and may cause damaging sliding movements to occur between the balls and raceways.

The requisite minimum radial load to be applied to deep groove ball bearings can be estimated using

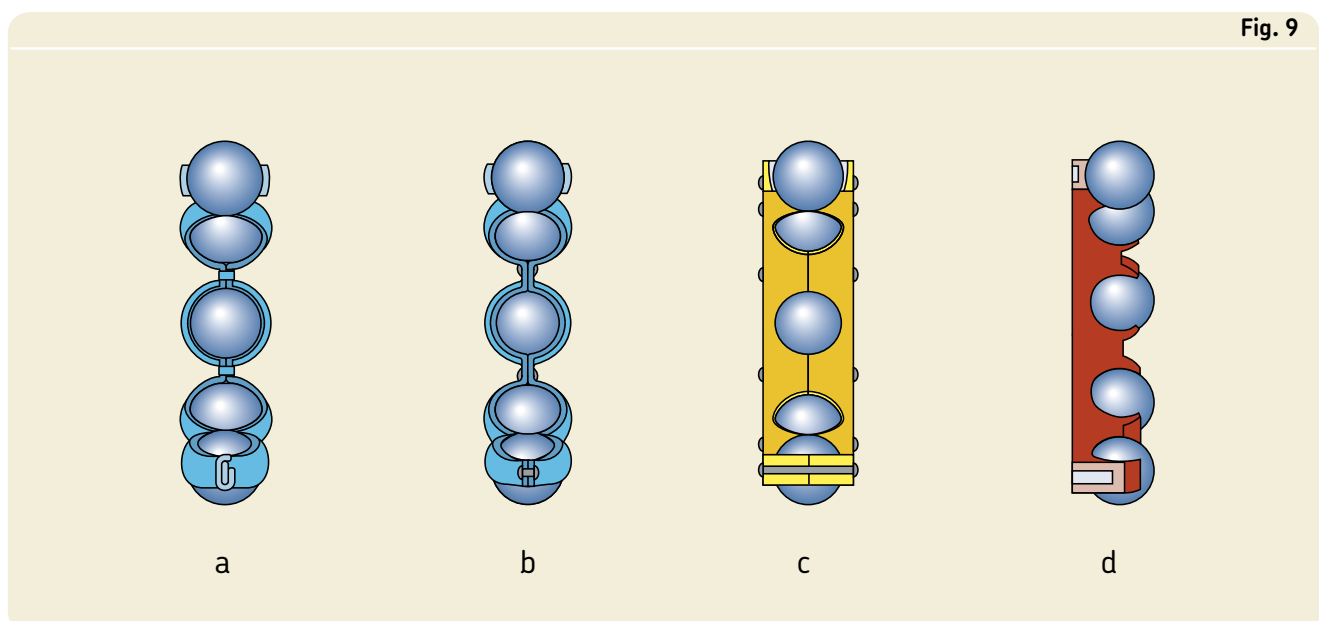

Fig. 9

$$F_{rm} = k_r \left(\frac{v n}{1\ 000} \right)^{2/3} \left(\frac{d_m}{100} \right)^2$$

where

F_{rm} = minimum radial load, kN

k_r = minimum load factor (→ product tables)

v = oil viscosity at operating temperature, mm²/s

n = rotational speed, r/min

d_m = bearing mean diameter
= 0,5 (d + D), mm

When starting up at low temperatures or when the lubricant is highly viscous, even greater minimum loads may be required. The weight of the components supported by the bearing, together with external forces, generally exceeds the requisite minimum load. If this is not the case, the deep groove ball bearing must be subjected to an additional radial load. For applications where deep groove ball bearings are used, an axial preload can be applied by adjusting the inner and outer rings against each other, or by using springs.

Axial load carrying capacity

If deep groove ball bearings are subjected to purely axial load, this axial load should generally not exceed the value of 0,5 C_0 . Small bearings (bore diameter up to approx. 12 mm) and light series bearings (Diameter Series 8, 9, 0, and 1) should not be subjected to an axial load greater

than 0,25 C_0 . Excessive axial loads can lead to a considerable reduction in bearing service life.

Equivalent dynamic bearing load

$$P = F_r \quad \text{when } F_a/F_r \leq e$$

$$P = X F_r + Y F_a \quad \text{when } F_a/F_r > e$$

The factors e and Y depend on the relationship $f_0 F_a/C_0$, where f_0 is a calculation factor (→ product tables), F_a the axial component of the load and C_0 the basic static load rating.

In addition, the factors are influenced by the magnitude of the radial internal clearance; increased clearance enables heavier axial loads to be supported. For bearings mounted with the usual fits as listed in the **tables 2, 4 and 5** on **pages 169 to 171**, the values for e , X and Y are listed in **table 5** below. If a clearance greater than Normal is chosen because a reduction in clearance is expected in operation, the values provided under "Normal clearance" should be used.

Equivalent static bearing load

$$P_0 = 0,6 F_r + 0,5 F_a$$

If $P_0 < F_r$, $P_0 = F_r$ should be used.

Table 5

Calculation factors for single row deep groove ball bearings									
$f_0 F_a/C_0$	Normal clearance			C3 clearance			C4 clearance		
	e	X	Y	e	X	Y	e	X	Y
0,172	0,19	0,56	2,30	0,29	0,46	1,88	0,38	0,44	1,47
0,345	0,22	0,56	1,99	0,32	0,46	1,71	0,40	0,44	1,40
0,689	0,26	0,56	1,71	0,36	0,46	1,52	0,43	0,44	1,30
1,03	0,28	0,56	1,55	0,38	0,46	1,41	0,46	0,44	1,23
1,38	0,30	0,56	1,45	0,40	0,46	1,34	0,47	0,44	1,19
2,07	0,34	0,56	1,31	0,44	0,46	1,23	0,50	0,44	1,12
3,45	0,38	0,56	1,15	0,49	0,46	1,10	0,55	0,44	1,02
5,17	0,42	0,56	1,04	0,54	0,46	1,01	0,56	0,44	1,00
6,89	0,44	0,56	1,00	0,54	0,46	1,00	0,56	0,44	1,00

Intermediate values are obtained by linear interpolation

Single row deep groove ball bearings

Supplementary designations

The designation suffixes used to identify certain features of SKF deep groove ball bearings are explained in the following.

CN	Normal radial internal clearance; normally only used together with an additional letter that identifies a reduced or displaced clearance range	LHT23	Grease with lithium thickener of consistency 2 to the NLGI Scale for a temperature range –50 to +140 °C (normal fill grade)
H	Reduced clearance range corresponding to the upper half of the actual clearance range	LT	Grease with lithium thickener of consistency 2 to the NLGI Scale for a temperature range –55 to +110 °C (normal fill grade)
L	Reduced clearance range corresponding to the lower half of the actual clearance range	LT10	Grease with lithium thickener of consistency 2 to the NLGI Scale for a temperature range –50 to +90 °C (normal fill grade)
P	Displaced clearance range comprising the upper half of the actual clearance range plus the lower half of the next larger clearance range	M	Machined brass cage, ball centred; different designs or material grades are identified by a figure following the M, e.g. M2
	The above letters are also used together with the clearance classes C2, C3, C4 and C5, e.g. C2H	MA	Machined brass cage, outer ring centred
C2	Radial internal clearance smaller than Normal	MB	Machined brass cage, inner ring centred
C3	Radial internal clearance greater than Normal	MT33	Grease with lithium thickener of consistency 3 to the NLGI Scale for a temperature range –30 to +120 °C (normal fill grade)
C4	Radial internal clearance greater than C3	MT47	Grease with lithium thickener of consistency 2 to the NLGI Scale for a temperature range –30 to +110 °C (normal fill grade)
C5	Radial internal clearance greater than C4	N	Snap ring groove in the outer ring
DB	Two single row deep groove ball bearings matched for paired mounting in a back-to-back arrangement	NR	Snap ring groove in the outer ring, with appropriate snap ring
DF	Two single row deep groove ball bearings matched for paired mounting in a face-to-face arrangement	N1	One locating slot (notch) in one outer ring sideface
DT	Two single row deep groove ball bearings matched for paired mounting in a tandem arrangement	P5	Dimensional and running accuracy to ISO tolerance class 5
E	Reinforced ball set	P6	Dimensional and running accuracy to ISO tolerance class 6
GJN	Grease with polyurea thickener of consistency 2 to the NLGI Scale for a temperature range –30 to +150 °C (normal fill grade)	P52	P5 + C2
GXN	Grease with polyurea thickener of consistency 2 to the NLGI Scale for a temperature range –40 to +150 °C (normal fill grade)	P62	P6 + C2
HT	Grease with polyurea thickener of consistency 2 to the NLGI Scale for a temperature range –40 to +150 °C (normal fill grade)	P63	P6 + C3
J	Pressed steel cage, ball centred	RS1	Sheet steel reinforced contact seal of acrylonitrile-butadiene rubber (NBR) on one side of the bearing
		2RS1	RS1 contact seal on both sides of the bearing
		RSH	Sheet steel reinforced contact seal of acrylonitrile-butadiene rubber (NBR) on one side of the bearing
		2RSH	RSH contact seal on both sides of the bearing

RSL	Sheet steel reinforced low friction contact seal of acrylonitrile-butadiene rubber (NBR) on one side of the bearing
2RSL	RSL low friction contact seal on both sides of the bearing
RZ	Sheet steel reinforced low friction seal of acrylonitrile-butadiene rubber (NBR) on one side of the bearing
2RZ	RZ low friction seal on both sides of the bearing
TH	Snap-type cage of fabric reinforced phenolic resin, ball centred
TN	Injection moulded snap-type cage of polyamide, ball centred
TNH	Injection moulded snap-type cage of polyetheretherketone (PEEK), ball centred
TN9	Injection moulded snap-type cage of glass fibre reinforced polyamide 6,6, ball centred
VL0241	Aluminium oxide coated outside surface of the outer ring for electrical resistance up to 1 000 V DC
VL2071	Aluminium oxide coated outside surface of the inner ring for electrical resistance up to 1 000 V DC
WT	Grease with polyurea thickener of consistency 2–3 to the NLGI Scale for a temperature range –40 to +160 °C (normal fill grade)
Y	Pressed brass cage, ball centred
Z	Shield of pressed sheet steel on one side of the bearing
2Z	Z shield on both sides of the bearing
ZNR	Shield of pressed sheet steel on one side of the bearing and snap ring groove in the outer ring with snap ring on the opposite side of the shield
2ZNR	Z shield on both sides of the bearing and snap ring groove in the outer ring with snap ring

Single row deep groove ball bearings

d 3 – 10 mm

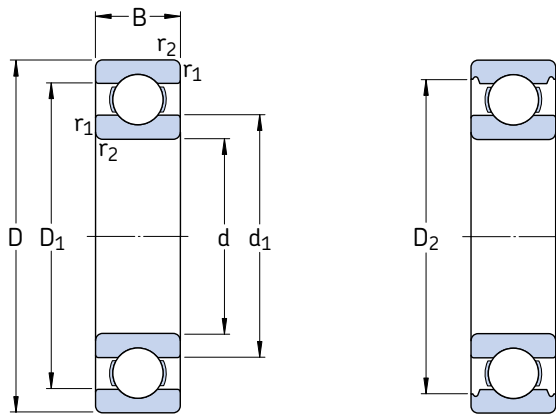

Principal dimensions			Basic load ratings		Fatigue load limit P_u	Speed ratings		Mass	Designation	MRP
d	D	B	dynamic C	static C_0		Reference speed	Limiting speed			
mm			kN		kN	r/min	kg	–		
3	10	4	0,54	0,18	0,007	130 000	80 000	0,0015	623	
4	9	2,5	0,54	0,18	0,007	140 000	85 000	0,0007	618/4	
	11	4	0,715	0,232	0,010	130 000	80 000	0,0017	619/4	
	12	4	0,806	0,28	0,012	120 000	75 000	0,0021	604	
	13	5	0,936	0,29	0,012	110 000	67 000	0,0031	624	
	16	5	1,11	0,38	0,016	95 000	60 000	0,0054	634	
5	11	3	0,637	0,255	0,011	120 000	75 000	0,0012	618/5	
	13	4	0,884	0,34	0,014	110 000	67 000	0,0025	619/5	
	16	5	1,14	0,38	0,016	95 000	60 000	0,0050	* 625	
	19	6	2,34	0,95	0,04	80 000	50 000	0,0090	* 635	
6	13	3,5	0,884	0,345	0,015	110 000	67 000	0,0020	618/6	
	15	5	1,24	0,475	0,02	100 000	63 000	0,0039	619/6	
	19	6	2,34	0,95	0,04	80 000	50 000	0,0084	* 626	
7	14	3,5	0,956	0,4	0,017	100 000	63 000	0,0022	618/7	
	17	5	1,48	0,56	0,024	90 000	56 000	0,0049	619/7	
	19	6	2,34	0,95	0,04	85 000	53 000	0,0075	* 607	
	22	7	3,45	1,37	0,057	70 000	45 000	0,013	* 627	
8	16	4	1,33	0,57	0,024	90 000	56 000	0,0030	618/8	
	19	6	1,9	0,735	0,031	80 000	50 000	0,0071	619/8	
	22	7	3,45	1,37	0,057	75 000	48 000	0,012	* 608	
	24	8	3,9	1,66	0,071	63 000	40 000	0,017	* 628	
9	17	4	1,43	0,64	0,027	85 000	53 000	0,0034	618/9	
	20	6	2,08	0,865	0,036	80 000	48 000	0,0076	619/9	
	24	7	3,9	1,66	0,071	70 000	43 000	0,014	* 609	
	26	8	4,75	1,96	0,083	60 000	38 000	0,020	* 629	
10	19	5	1,38	0,585	0,025	80 000	48 000	0,0055	61800	
	22	6	2,08	0,85	0,036	75 000	45 000	0,010	61900	
	26	8	4,75	1,96	0,083	67 000	40 000	0,019	* 6000	
	28	8	4,62	1,96	0,083	63 000	40 000	0,022	16100	
	30	9	5,4	2,36	0,1	56 000	34 000	0,032	* 6200	
	35	11	8,52	3,4	0,143	50 000	32 000	0,053	* 6300	

* SKF Explorer bearing

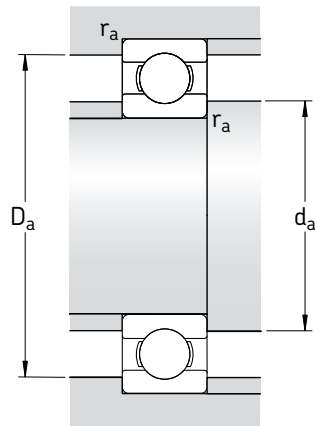

Dimensions					Abutment and fillet dimensions			Calculation factors	
d	d_1 ~	D_1 ~	D_2 ~	$r_{1,2}$ min	d_a min	D_a max	r_a max	k_r	f_0
mm					mm			-	
3	5,2	7,5	8,2	0,15	4,2	8,8	0,1	0,025	7,5
4	5,2	7,5	-	0,1	4,6	8,4	0,1	0,015	10
	5,9	9	9,8	0,15	4,8	10,2	0,1	0,02	9,9
	6,1	9	-	0,2	5,4	10,6	0,2	0,025	10
	6,7	10,3	11,2	0,2	5,8	11,2	0,2	0,025	10
	8,4	12	13,3	0,3	6,4	13,6	0,3	0,03	8,4
5	6,8	9,3	-	0,15	5,8	10,2	0,1	0,015	11
	7,6	10,8	11,4	0,2	6,4	11,6	0,2	0,02	11
	8,4	12	13,3	0,3	7,4	13,6	0,3	0,025	8,4
	10,7	15,3	16,5	0,3	7,4	16,6	0,3	0,03	13
6	7,9	11,2	-	0,15	6,8	12,2	0,1	0,015	11
	8,6	12,4	13,3	0,2	7,4	13,6	0,2	0,02	10
	11,1	15,2	16,5	0,3	8,4	16,6	0,3	0,025	13
7	8,9	12,2	-	0,15	7,8	13,2	0,1	0,015	11
	9,8	14,2	15,2	0,3	9	15	0,3	0,02	10
	11,1	15,2	16,5	0,3	9	17	0,3	0,025	13
	12,2	17,6	19,2	0,3	9,4	19,6	0,3	0,025	12
8	10,1	14	-	0,2	9,4	14,6	0,2	0,015	11
	11,1	16,1	19	0,3	10	17	0,3	0,02	10
	12,1	17,6	19,2	0,3	10	20	0,3	0,025	12
	14,5	19,8	20,6	0,3	10,4	21,6	0,3	0,025	13
9	11,1	15	-	0,2	10,4	15,6	0,2	0,015	11
	12	17	17,9	0,3	11	18	0,3	0,02	11
	14,4	19,8	21,2	0,3	11	22	0,3	0,025	13
	14,8	21,2	22,6	0,3	11,4	23,6	0,3	0,025	12
10	12,6	16,4	-	0,3	12	17	0,3	0,015	9,4
	13	18,1	19	0,3	12	20	0,3	0,02	9,3
	14,8	21,2	22,6	0,3	12	24	0,3	0,025	12
	16,7	23,4	24,8	0,6	14,2	23,8	0,3	0,025	13
	17	23,2	24,8	0,6	14,2	25,8	0,6	0,025	13
	17,5	26,9	28,7	0,6	14,2	30,8	0,6	0,03	11

Single row deep groove ball bearings
d 12 – 22 mm

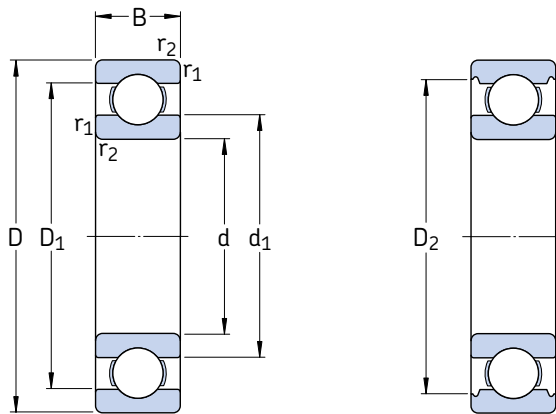

Principal dimensions			Basic load ratings		Fatigue load limit P_u	Speed ratings		Mass	Designation
d	D	B	C	C_0		Reference speed	Limiting speed		
mm			kN		kN	r/min	kg	–	
12	21	5	1,43	0,67	0,028	70 000	43 000	0,0063	61801
	24	6	2,25	0,98	0,043	67 000	40 000	0,011	61901
	28	8	5,4	2,36	0,10	60 000	38 000	0,022	* 6001
	30	8	5,07	2,36	0,10	56 000	34 000	0,023	16101
	32	10	7,28	3,1	0,132	50 000	32 000	0,037	* 6201
	37	12	10,1	4,15	0,176	45 000	28 000	0,060	* 6301
15	24	5	1,56	0,8	0,034	60 000	38 000	0,0074	61802
	28	7	4,36	2,24	0,095	56 000	34 000	0,016	61902
	32	8	5,85	2,85	0,12	50 000	32 000	0,025	* 16002
	32	9	5,85	2,85	0,12	50 000	32 000	0,030	* 6002
	35	11	8,06	3,75	0,16	43 000	28 000	0,045	* 6202
	42	13	11,9	5,4	0,228	38 000	24 000	0,082	* 6302
17	26	5	1,68	0,93	0,039	56 000	34 000	0,0082	61803
	30	7	4,62	2,55	0,108	50 000	32 000	0,018	61903
	35	8	6,37	3,25	0,137	45 000	28 000	0,032	* 16003
	35	10	6,37	3,25	0,137	45 000	28 000	0,039	* 6003
	40	9	9,56	4,75	0,2	38 000	24 000	0,048	98203
	40	12	9,95	4,75	0,2	38 000	24 000	0,065	* 6203
	40	12	11,4	5,4	0,228	38 000	24 000	0,064	6203 ETN9
	47	14	14,3	6,55	0,275	34 000	22 000	0,12	* 6303
62	17	22,9	10,8	0,455	28 000	18 000	0,27	6403	
20	32	7	4,03	2,32	0,104	45 000	28 000	0,018	61804
	37	9	6,37	3,65	0,156	43 000	26 000	0,038	61904
	42	8	7,28	4,05	0,173	38 000	24 000	0,050	* 16004
	42	9	7,93	4,5	0,19	38 000	24 000	0,051	98204 Y
	42	12	9,95	5	0,212	38 000	24 000	0,069	* 6004
	47	14	13,5	6,55	0,28	32 000	20 000	0,11	* 6204
	47	14	15,6	7,65	0,325	32 000	20 000	0,096	6204 ETN9
	52	15	16,8	7,8	0,335	30 000	19 000	0,14	* 6304
	52	15	18,2	9	0,38	30 000	19 000	0,14	6304 ETN9
	72	19	30,7	15	0,64	24 000	15 000	0,40	6404
22	50	14	14	7,65	0,325	30 000	19 000	0,12	62/22
	56	16	18,6	9,3	0,39	28 000	18 000	0,18	63/22

* SKF Explorer bearing

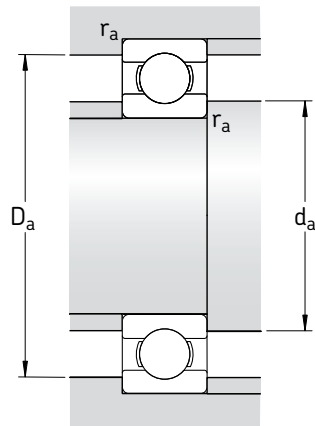

Dimensions					Abutment and fillet dimensions			Calculation factors		
d	d ₁ ~	D ₁ ~	D ₂ ~	r _{1,2} min	d _a min	D _a max	r _a max	k _r	f ₀	
mm					mm			-		
12	15	18,2	-	0,3	14	19	0,3	0,015	9,7	
	15,5	20,6	21,4	0,3	14	22	0,3	0,02	9,7	
	17	23,2	24,8	0,3	14	26	0,3	0,025	13	
	16,7	23,4	24,8	0,3	14,4	27,6	0,3	0,025	13	
	18,5	25,7	27,4	0,6	16,2	27,8	0,6	0,025	12	
	19,5	29,5	31,5	1	17,6	31,4	1	0,03	11	
15	17,9	21,1	-	0,3	17	22	0,3	0,015	10	
	18,4	24,7	25,8	0,3	17	26	0,3	0,02	14	
	20,2	27	28,2	0,3	17	30	0,3	0,02	14	
	20,5	26,7	28,2	0,3	17	30	0,3	0,025	14	
	21,7	29	30,4	0,6	19,2	30,8	0,6	0,025	13	
	23,7	33,7	36,3	1	20,6	36,4	1	0,03	12	
17	20,2	23,2	-	0,3	19	24	0,3	0,015	10	
	20,4	26,7	27,8	0,3	19	28	0,3	0,02	15	
	22,7	29,5	31,2	0,3	19	33	0,3	0,02	14	
	23	29,2	31,4	0,3	19	33	0,3	0,025	14	
	24,5	32,7	-	0,6	21,2	35,8	0,6	0,025	13	
	24,5	32,7	35	0,6	21,2	35,8	0,6	0,025	13	
	23,9	33,5	-	0,6	21,2	35,8	0,6	0,03	12	
	26,5	37,4	39,7	1	22,6	41,4	1	0,03	12	
	32,4	46,6	-	1,1	23,5	55,5	1	0,035	11	
	20	24	28,3	-	0,3	22	30	0,3	0,015	15
		25,6	31,4	32,8	0,3	22	35	0,3	0,02	15
		27,3	34,6	-	0,3	22	40	0,3	0,02	15
27,4		36	36,2	0,6	23,2	38,8	0,6	0,025	14	
27,2		34,8	37,2	0,6	23,2	38,8	0,6	0,025	14	
28,8		38,5	40,6	1	25,6	41,4	1	0,025	13	
28,2		39,6	-	1	25,6	41,4	1	0,025	12	
30,4		41,6	44,8	1,1	27	45	1	0,03	12	
30,2		42,6	-	1,1	27	45	1	0,03	12	
37,1		54,8	-	1,1	29	63	1	0,035	11	
22		32,2	41,8	44	1	27,6	44,4	1	0,025	14
		32,9	45,3	-	1,1	29	47	1	0,03	12

Single row deep groove ball bearings

d 25 – 35 mm

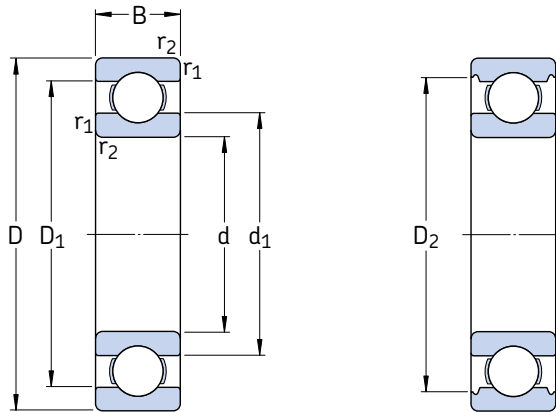

Principal dimensions			Basic load ratings		Fatigue load limit P_u	Speed ratings		Mass	Designation
d	D	B	C	C_0		Reference speed	Limiting speed		
mm			kN		kN	r/min		kg	–
25	37	7	4,36	2,6	0,125	38 000	24 000	0,022	61805
	42	9	7,02	4,3	0,193	36 000	22 000	0,045	61905
	47	8	8,06	4,75	0,212	32 000	20 000	0,060	* 16005
	47	12	11,9	6,55	0,275	32 000	20 000	0,080	* 6005
	52	9	10,6	6,55	0,28	28 000	18 000	0,078	98205
	52	15	14,8	7,8	0,335	28 000	18 000	0,13	* 6205
	52	15	17,8	9,8	0,40	28 000	18 000	0,12	6205 ETN9
	62	17	23,4	11,6	0,49	24 000	16 000	0,23	* 6305
	62	17	26	13,4	0,57	24 000	16 000	0,21	6305 ETN9
	80	21	35,8	19,3	0,82	20 000	13 000	0,53	6405
28	58	16	16,8	9,5	0,405	26 000	16 000	0,18	62/28
	68	18	25,1	13,7	0,585	22 000	14 000	0,29	63/28
30	42	7	4,49	2,9	0,146	32 000	20 000	0,027	61806
	47	9	7,28	4,55	0,212	30 000	19 000	0,051	61906
	55	9	11,9	7,35	0,31	28 000	17 000	0,085	* 16006
	55	13	13,8	8,3	0,355	28 000	17 000	0,12	* 6006
	62	10	15,9	10,2	0,44	22 000	14 000	0,12	98206
	62	16	20,3	11,2	0,48	24 000	15 000	0,20	* 6206
	62	16	23,4	12,9	0,54	24 000	15 000	0,19	6206 ETN9
	72	19	29,6	16	0,67	20 000	13 000	0,35	* 6306
	72	19	32,5	17,3	0,74	22 000	14 000	0,33	6306 ETN9
	90	23	43,6	23,6	1,00	18 000	11 000	0,74	6406
35	47	7	4,75	3,2	0,17	28 000	18 000	0,030	61807
	55	10	9,56	6,8	0,29	26 000	16 000	0,080	61907
	62	9	13	8,15	0,38	24 000	15 000	0,11	* 16007
	62	14	16,8	10,2	0,44	24 000	15 000	0,16	* 6007
	72	17	27	15,3	0,66	20 000	13 000	0,29	* 6207
	72	17	31,2	17,6	0,75	20 000	13 000	0,27	6207 ETN9
	80	21	35,1	19	0,82	19 000	12 000	0,46	* 6307
	100	25	55,3	31	1,29	16 000	10 000	0,95	6407

* SKF Explorer bearing

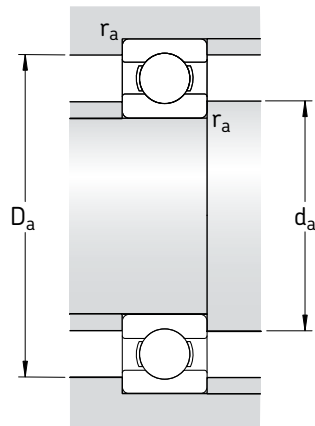

Dimensions					Abutment and fillet dimensions			Calculation factors		
d	d ₁ ~	D ₁ ~	D ₂ ~	r _{1,2} min	d _a min	D _a max	r _a max	k _r	f ₀	
mm					mm			-		
25	28,5	33,3	-	0,3	27	35	0,3	0,015	14	
	30,2	36,8	37,8	0,3	27	40	0,3	0,02	15	
	33,3	40,7	-	0,3	27	45	0,3	0,02	15	
	32	40	42,2	0,6	28,2	43,8	0,6	0,025	14	
	34,5	44	-	0,6	28,2	48,8	0,6	0,025	15	
	34,4	44	46,3	1	30,6	46,4	1	0,025	14	
	33,1	44,5	-	1	30,6	46,4	1	0,025	13	
	36,6	50,4	52,7	1,1	32	55	1	0,03	12	
	36,4	51,7	-	1,1	32	55	1	0,03	12	
	45,4	62,9	-	1,5	34	71	1,5	0,035	12	
	28	37	49,2	-	1	33,6	52,4	1	0,025	14
		41,7	56	-	1,1	35	61	1	0,03	13
30	33,7	38,5	-	0,3	32	40	0,3	0,015	14	
	35,2	41,8	42,8	0,3	32	45	0,3	0,02	14	
	37,7	47,3	-	0,3	32	53	0,3	0,02	15	
	38,2	46,8	49	1	34,6	50,4	1	0,025	15	
	42,9	54,4	-	0,6	33,2	58,8	0,6	0,025	14	
	40,4	51,6	54,1	1	35,6	56,4	1	0,025	14	
	39,5	52,9	-	1	35,6	56,4	1	0,025	13	
	44,6	59,1	61,9	1,1	37	65	1	0,03	13	
	42,5	59,7	-	1,1	37	65	1	0,03	12	
	50,3	69,7	-	1,5	41	79	1,5	0,035	12	
35	38,7	43,5	-	0,3	37	45	0,3	0,015	14	
	41,6	48,4	-	0,6	38,2	51,8	0,6	0,02	14	
	44,1	53	-	0,3	37	60	0,3	0,02	14	
	43,8	53,3	55,6	1	39,6	57,4	1	0,025	15	
	46,9	60	62,7	1,1	42	65	1	0,025	14	
	46,1	61,7	-	1,1	42	65	1	0,025	13	
	49,6	65,4	69,2	1,5	44	71	1,5	0,03	13	
	57,4	79,5	-	1,5	46	89	1,5	0,035	12	

Single row deep groove ball bearings
d 40 – 60 mm

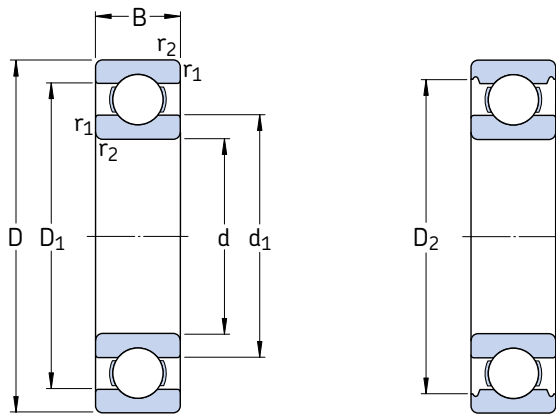

Principal dimensions			Basic load ratings		Fatigue load limit P_u	Speed ratings		Mass	Designation
d	D	B	dynamic C	static C_0		Reference speed	Limiting speed		
mm			kN		kN	r/min		kg	–
40	52	7	4,94	3,45	0,19	26 000	16 000	0,034	61808
	62	12	13,8	10	0,43	24 000	14 000	0,12	61908
	68	9	13,8	9,15	0,44	22 000	14 000	0,13	* 16008
	68	15	17,8	11,6	0,49	22 000	14 000	0,19	* 6008
	80	18	32,5	19	0,80	18 000	11 000	0,37	* 6208
	80	18	35,8	20,8	0,88	18 000	11 000	0,34	6208 ETN9
	90	23	42,3	24	1,02	17 000	11 000	0,63	* 6308
110	27	63,7	36,5	1,53	14 000	9 000	1,25	6408	
45	58	7	6,63	6,1	0,26	22 000	14 000	0,040	61809
	68	12	14	10,8	0,47	20 000	13 000	0,14	61909
	75	10	16,5	10,8	0,52	20 000	12 000	0,17	* 16009
	75	16	22,1	14,6	0,64	20 000	12 000	0,25	* 6009
	85	19	35,1	21,6	0,92	17 000	11 000	0,41	* 6209
	100	25	55,3	31,5	1,34	15 000	9 500	0,83	* 6309
	120	29	76,1	45	1,90	13 000	8 500	1,55	6409
50	65	7	6,76	6,8	0,285	20 000	13 000	0,052	61810
	72	12	14,6	11,8	0,50	19 000	12 000	0,14	61910
	80	10	16,8	11,4	0,56	18 000	11 000	0,18	* 16010
	80	16	22,9	16	0,71	18 000	11 000	0,26	* 6010
	90	20	37,1	23,2	0,98	15 000	10 000	0,46	* 6210
	110	27	65	38	1,6	13 000	8 500	1,05	* 6310
	130	31	87,1	52	2,2	12 000	7 500	1,9	6410
55	72	9	9,04	8,8	0,38	19 000	12 000	0,083	61811
	80	13	16,5	14	0,60	17 000	11 000	0,19	61911
	90	11	20,3	14	0,70	16 000	10 000	0,26	* 16011
	90	18	29,6	21,2	0,90	16 000	10 000	0,39	* 6011
	100	21	46,2	29	1,25	14 000	9 000	0,61	* 6211
	120	29	74,1	45	1,90	12 000	8 000	1,35	* 6311
	140	33	99,5	62	2,60	11 000	7 000	2,3	6411
60	78	10	11,9	11,4	0,49	17 000	11 000	0,11	61812
	85	13	16,5	14,3	0,60	16 000	10 000	0,20	61912
	95	11	20,8	15	0,74	15 000	9 500	0,28	* 16012
	95	18	30,7	23,2	0,98	15 000	9 500	0,42	* 6012
	110	22	55,3	36	1,53	13 000	8 000	0,78	* 6212
	130	31	85,2	52	2,20	11 000	7 000	1,7	* 6312
	150	35	108	69,5	2,90	10 000	6 300	2,75	6412

* SKF Explorer bearing

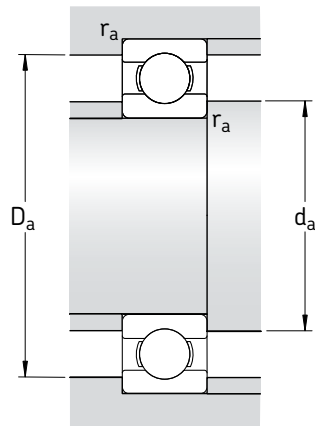

Dimensions					Abutment and fillet dimensions			Calculation factors	
d	d ₁ ~	D ₁ ~	D ₂ ~	r _{1,2} min	d _a min	D _a max	r _a max	k _r	f ₀
mm					mm			-	
40	43,7	48,5	-	0,3	42	50	0,3	0,015	14
	46,9	55,1	-	0,6	43,2	58,8	0,6	0,02	16
	49,4	58,6	-	0,3	42	66	0,3	0,02	14
	49,3	58,8	61,1	1	44,6	63,4	1	0,025	15
	52,6	67,4	69,8	1,1	47	73	1	0,025	14
	52	68,8	-	1,1	47	73	1	0,025	13
	56,1	73,8	77,7	1,5	49	81	1,5	0,03	13
	62,8	87	-	2	53	97	2	0,035	12
45	49,1	53,9	-	0,3	47	56	0,3	0,015	17
	52,4	60,6	-	0,6	48,2	64,8	0,6	0,02	16
	55	65,4	-	0,6	48,2	71,8	0,6	0,02	14
	54,8	65,3	67,8	1	50,8	69,2	1	0,025	15
	57,6	72,4	75,2	1,1	52	78	1	0,025	14
	62,2	82,7	86,7	1,5	54	91	1,5	0,03	13
	68,9	95,8	-	2	58	107	2	0,035	12
	50	55,1	59,9	-	0,3	52	63	0,3	0,015
56,9		65,1	-	0,6	53,2	68,8	0,6	0,02	16
60		70	-	0,6	53,2	76,8	0,6	0,02	14
59,8		70,3	72,8	1	54,6	75,4	1	0,025	15
62,5		77,4	81,6	1,1	57	83	1	0,025	14
68,8		91,1	95,2	2	61	99	2	0,03	13
75,5		104	-	2,1	64	116	2	0,035	12
55		60,6	66,4	-	0,3	57	70	0,3	0,015
	63,2	71,8	-	1	59,6	75,4	1	0,02	16
	67	78,1	-	0,6	58,2	86,8	0,6	0,02	15
	66,3	78,7	81,5	1,1	61	84	1	0,025	15
	69,1	85,8	89,4	1,5	64	91	1,5	0,025	14
	75,3	99,5	104	2	66	109	2	0,03	13
	81,6	113	-	2,1	69	126	2	0,035	12
	60	65,6	72,4	-	0,3	62	76	0,3	0,015
68,2		76,8	-	1	64,6	80,4	1	0,02	16
72		83	-	0,6	63,2	91,8	0,6	0,02	14
71,3		83,7	86,5	1,1	66	89	1	0,025	16
75,5		94,6	98	1,5	69	101	1,5	0,025	14
81,9		108	112	2,1	72	118	2	0,03	13
88,1		122	-	2,1	74	136	2	0,035	12

Single row deep groove ball bearings

d 65 – 85 mm

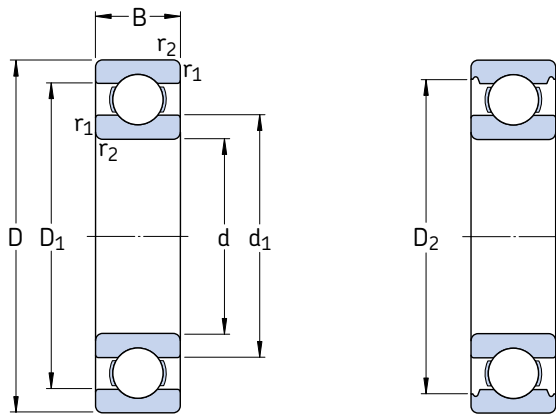

Principal dimensions			Basic load ratings		Fatigue load limit P_u	Speed ratings		Mass	Designation
d	D	B	dynamic C	static C_0		Reference speed	Limiting speed		
mm			kN		kN	r/min		kg	–
65	85	10	12,4	12,7	0,54	16 000	10 000	0,13	61813
	90	13	17,4	16	0,68	15 000	9 500	0,22	61913
	100	11	22,5	16,6	0,83	14 000	9 000	0,30	* 16013
	100	18	31,9	25	1,06	14 000	9 000	0,44	* 6013
	120	23	58,5	40,5	1,73	12 000	7 500	0,99	* 6213
	140	33	97,5	60	2,5	10 000	6 700	2,10	* 6313
	160	37	119	78	3,15	9 500	6 000	3,30	6413
70	90	10	12,4	13,2	0,56	15 000	9 000	0,14	61814
	100	16	23,8	21,2	0,9	14 000	8 500	0,35	61914
	110	13	29,1	25	1,06	13 000	8 000	0,43	* 16014
	110	20	39,7	31	1,32	13 000	8 000	0,60	* 6014
	125	24	63,7	45	1,9	11 000	7 000	1,05	* 6214
	150	35	111	68	2,75	9 500	6 300	2,50	* 6314
	180	42	143	104	3,9	8 500	5 300	4,85	6414
75	95	10	12,7	14,3	0,61	14 000	8 500	0,15	61815
	105	16	24,2	19,3	0,965	13 000	8 000	0,37	61915
	110	12	28,6	27	1,14	13 000	8 000	0,38	16115
	115	13	30,2	27	1,14	12 000	7 500	0,46	* 16015
	115	20	41,6	33,5	1,43	12 000	7 500	0,64	* 6015
	130	25	68,9	49	2,04	10 000	6 700	1,20	* 6215
	160	37	119	76,5	3	9 000	5 600	3,00	* 6315
	190	45	153	114	4,15	8 000	5 000	6,80	6415
80	100	10	13	15	0,64	13 000	8 000	0,15	61816
	110	16	25,1	20,4	1,02	12 000	7 500	0,40	61916
	125	14	35,1	31,5	1,32	11 000	7 000	0,60	* 16016
	125	22	49,4	40	1,66	11 000	7 000	0,85	* 6016
	140	26	72,8	55	2,2	9 500	6 000	1,40	* 6216
	170	39	130	86,5	3,25	8 500	5 300	3,60	* 6316
	200	48	163	125	4,5	7 500	4 800	8,00	6416
85	110	13	19,5	20,8	0,88	12 000	7 500	0,27	61817
	120	18	31,9	30	1,25	11 000	7 000	0,55	61917
	130	14	35,8	33,5	1,37	11 000	6 700	0,63	* 16017
	130	22	52	43	1,76	11 000	6 700	0,89	* 6017
	150	28	87,1	64	2,5	9 000	5 600	1,80	* 6217
	180	41	140	96,5	3,55	8 000	5 000	4,25	* 6317
	210	52	174	137	4,75	7 000	4 500	9,50	6417

* SKF Explorer bearing

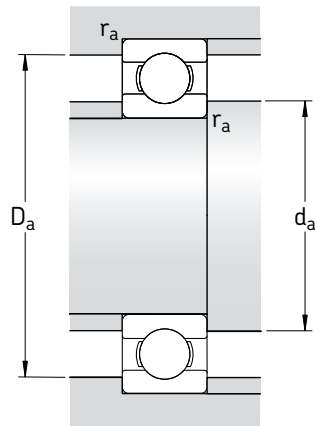

Dimensions					Abutment and fillet dimensions			Calculation factors	
d	d ₁ ~	D ₁ ~	D ₂ ~	r _{1,2} min	d _a min	D _a max	r _a max	k _r	f ₀
mm					mm			-	
65	71,6	78,4	-	0,6	68,2	81,8	0,6	0,015	17
	73,2	81,8	-	1	69,6	85,4	1	0,02	17
	76,5	88,4	-	0,6	68,2	96,8	0,6	0,02	16
	76,3	88,7	91,5	1,1	71	94	1	0,025	16
	83,3	102	106	1,5	74	111	1,5	0,025	15
	88,4	116	121	2,1	77	128	2	0,03	13
	94	131	-	2,1	79	146	2	0,035	12
70	76,6	83,4	-	0,6	73,2	86,8	0,6	0,015	17
	79,7	90,3	-	1	74,6	95,4	1	0,02	16
	83,3	96,8	-	0,6	73,2	106	0,6	0,02	16
	82,9	97,2	99,9	1,1	76	104	1	0,025	16
	87,1	108	111	1,5	79	116	1,5	0,025	15
	95	125	130	2,1	82	138	2	0,03	13
	104	146	-	3	86	164	2,5	0,035	12
75	81,6	88,4	-	0,6	78,2	91,8	0,6	0,015	17
	84,7	95,3	-	1	79,6	100	1	0,02	14
	88,3	102	-	0,6	77	108	0,3	0,02	16
	88,3	102	-	0,6	78,2	111	0,6	0,02	16
	87,9	102	105	1,1	81	109	1	0,025	16
	92,1	113	117	1,5	84	121	1,5	0,025	15
	101	133	138	2,1	87	148	2	0,03	13
	110	154	-	3	91	174	2,5	0,035	12
80	86,6	93,4	-	0,6	83,2	96,8	0,6	0,015	17
	89,8	100	102	1	84,6	105	1	0,02	14
	95,3	110	-	0,6	83,2	121	0,6	0,02	16
	94,4	111	114	1,1	86	119	1	0,025	16
	101	122	127	2	91	129	2	0,025	15
	108	142	147	2,1	92	158	2	0,03	13
	117	163	-	3	96	184	2,5	0,035	12
	85	93,2	102	-	1	89,6	105	1	0,015
96,4		109	-	1,1	91	114	1	0,02	16
100		115	-	0,6	88,2	126	0,6	0,02	16
99,4		116	119	1,1	92	123	1	0,025	16
106		130	134	2	96	139	2	0,025	15
115		151	155	3	99	166	2,5	0,03	13
123		171	-	4	105	190	3	0,035	12

Single row deep groove ball bearings
d 90 – 110 mm

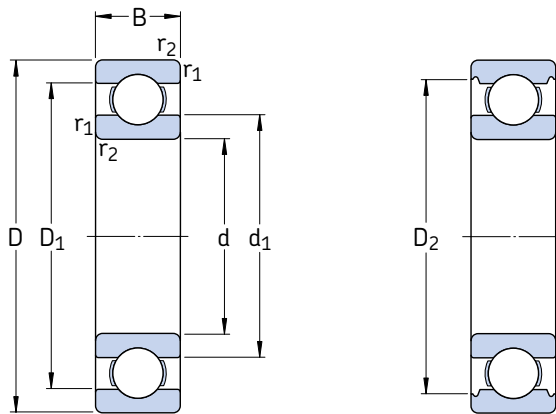

Principal dimensions			Basic load ratings		Fatigue load limit P_u	Speed ratings		Mass	Designation
d	D	B	dynamic C	static C_0		Reference speed	Limiting speed		
mm			kN		kN	r/min		kg	–
90	115	13	19,5	22	0,915	11 000	7 000	0,28	61818
	125	18	33,2	31,5	1,23	11 000	6 700	0,59	61918
	140	16	43,6	39	1,56	10 000	6 300	0,85	* 16018
	140	24	60,5	50	1,96	10 000	6 300	1,15	* 6018
	160	30	101	73,5	2,8	8 500	5 300	2,15	* 6218
	190	43	151	108	3,8	7 500	4 800	4,90	* 6318
	225	54	186	150	5	6 700	4 300	11,5	6418
95	120	13	19,9	22,8	0,93	11 000	6 700	0,30	61819
	130	18	33,8	33,5	1,43	10 000	6 300	0,61	61919
	145	16	44,8	41,5	1,63	9 500	6 000	0,89	* 16019
	145	24	63,7	54	2,08	9 500	6 000	1,20	* 6019
	170	32	114	81,5	3	8 000	5 000	2,60	* 6219
	200	45	159	118	4,15	7 000	4 500	5,65	* 6319
100	125	13	19,9	24	0,95	10 000	6 300	0,31	61820
	140	20	42,3	41	1,63	9 500	6 000	0,83	61920
	150	16	46,2	44	1,73	9 500	5 600	0,91	* 16020
	150	24	63,7	54	2,04	9 500	5 600	1,25	* 6020
	180	34	127	93	3,35	7 500	4 800	3,15	* 6220
	215	47	174	140	4,75	6 700	4 300	7,00	6320
105	130	13	20,8	19,6	1	10 000	6 300	0,32	61821
	145	20	44,2	44	1,7	9 500	5 600	0,87	61921
	160	18	54	51	1,86	8 500	5 300	1,20	* 16021
	160	26	76,1	65,5	2,4	8 500	5 300	1,60	* 6021
	190	36	140	104	3,65	7 000	4 500	3,70	* 6221
	225	49	182	153	5,1	6 300	4 000	8,25	6321
110	140	16	28,1	26	1,25	9 500	5 600	0,60	61822
	150	20	43,6	45	1,66	9 000	5 600	0,90	61922
	170	19	60,2	57	2,04	8 000	5 000	1,45	* 16022
	170	28	85,2	73,5	2,4	8 000	5 000	1,95	* 6022
	200	38	151	118	4	6 700	4 300	4,35	* 6222
	240	50	203	180	5,7	6 000	3 800	9,55	6322

* SKF Explorer bearing

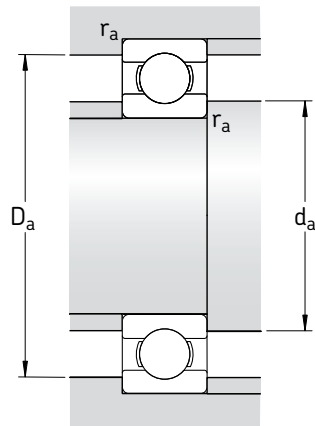

Dimensions					Abutment and fillet dimensions			Calculation factors	
d	d ₁ ~	D ₁ ~	D ₂ ~	r _{1,2} min	d _a min	D _a max	r _a max	k _r	f ₀
mm					mm			-	
90	98,2	107	-	1	94,6	110	1	0,015	17
	101	114	117	1,1	96	119	1	0,02	16
	107	123	-	1	94,6	135	1	0,02	16
	106	124	128	1,5	97	133	1,5	0,025	16
	113	138	143	2	101	149	2	0,025	15
	121	159	164	3	104	176	2,5	0,03	13
	132	181	-	4	110	205	3	0,035	12
95	103	112	-	1	99,6	115	1	0,015	17
	106	119	122	1,1	101	124	1	0,02	17
	112	128	-	1	99,6	140	1	0,02	16
	111	129	133	1,5	102	138	1,5	0,025	16
	118	146	151	2,1	107	158	2	0,025	14
	128	167	172	3	109	186	2,5	0,03	13
100	108	117	-	1	105	120	1	0,015	17
	113	127	-	1,1	106	134	1	0,02	16
	116	134	-	1	105	145	1	0,02	17
	116	134	138	1,5	107	143	1,5	0,025	16
	125	155	160	2,1	112	168	2	0,025	14
	136	179	184	3	114	201	2,5	0,03	13
105	112	123	-	1	110	125	1	0,015	13
	118	132	-	1,1	111	139	1	0,02	17
	123	142	-	1	110	155	1	0,02	16
	123	143	147	2	116	149	2	0,025	16
	131	163	167	2,1	117	178	2	0,025	14
	142	188	-	3	119	211	2,5	0,03	13
110	119	131	-	1	115	135	1	0,015	14
	123	137	-	1,1	116	144	1	0,02	17
	130	150	-	1	115	165	1	0,02	16
	129	151	155	2	119	161	2	0,025	16
	138	172	177	2,1	122	188	2	0,025	14
	150	200	-	3	124	226	2,5	0,03	13

Single row deep groove ball bearings
d 120 – 170 mm

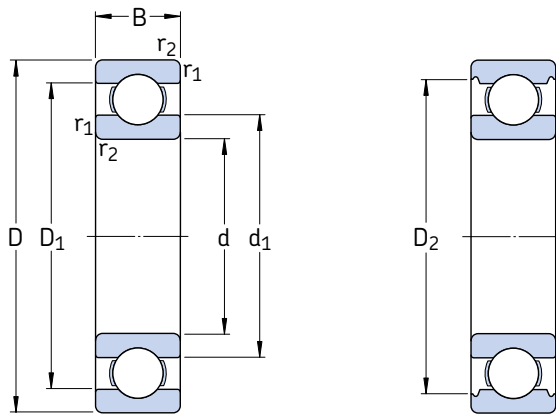

Principal dimensions			Basic load ratings		Fatigue load limit P_u	Speed ratings		Mass	Designation
d	D	B	dynamic C	static C_0		Reference speed	Limiting speed		
mm			kN		kN	r/min		kg	–
120	150	16	29,1	28	1,29	8 500	5 300	0,65	61824
	165	22	55,3	57	2,04	8 000	5 000	1,20	61924
	180	19	63,7	64	2,2	7 500	4 800	1,60	* 16024
	180	28	88,4	80	2,75	7 500	4 800	2,05	* 6024
	215	40	146	118	3,9	6 300	4 000	5,15	6224
260	55	208	186	5,7	5 600	3 400	12,5	6324	
130	165	18	37,7	43	1,6	8 000	4 800	0,93	61826
	180	24	65	67	2,28	7 500	4 500	1,85	61926
	200	22	83,2	81,5	2,7	7 000	4 300	2,35	* 16026
	200	33	112	100	3,35	7 000	4 300	3,15	* 6026
	230	40	156	132	4,15	5 600	3 600	5,80	6226
280	58	229	216	6,3	5 000	3 200	17,5	6326 M	
140	175	18	39	46,5	1,66	7 500	4 500	0,99	61828
	190	24	66,3	72	2,36	7 000	5 600	1,70	61928 MA
	210	22	80,6	86,5	2,8	6 700	4 000	2,50	16028
	210	33	111	108	3,45	6 700	4 000	3,35	6028
	250	42	165	150	4,55	5 300	3 400	7,45	6228
300	62	251	245	7,1	4 800	4 300	22,0	6328 M	
150	190	20	48,8	61	1,96	6 700	4 300	1,40	61830
	210	28	88,4	93	2,9	6 300	5 300	3,05	61930 MA
	225	24	92,2	98	3,05	6 000	3 800	3,15	16030
	225	35	125	125	3,9	6 000	3 800	4,80	6030
	270	45	174	166	4,9	5 000	3 200	9,40	6230
320	65	276	285	7,8	4 300	4 000	26,0	6330 M	
160	200	20	49,4	64	2	6 300	4 000	1,45	61832
	220	28	92,3	98	3,05	6 000	5 000	3,25	61932 MA
	240	25	99,5	108	3,25	5 600	3 600	3,70	16032
	240	38	143	143	4,3	5 600	3 600	5,90	6032
	290	48	186	186	5,3	4 500	3 000	14,5	6232
340	68	276	285	7,65	4 000	3 800	29,0	6332 M	
170	215	22	61,8	78	2,4	6 000	3 600	1,90	61834
	230	28	93,6	106	3,15	5 600	4 800	3,40	61934 MA
	260	28	119	129	3,75	5 300	3 200	5,00	16034
	260	42	168	173	5	5 300	4 300	7,90	6034 M
	310	52	212	224	6,1	4 300	3 800	17,5	6234 M
360	72	312	340	8,8	3 800	3 400	34,5	6334 M	

* SKF Explorer bearing

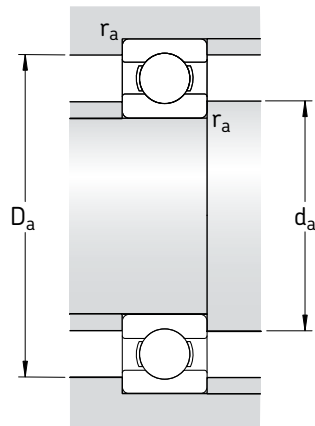

Dimensions					Abutment and fillet dimensions			Calculation factors	
d	d_1	D_1	D_2	$r_{1,2}$ min	d_a min	D_a max	r_a max	k_r	f_0
mm					mm			-	
120	129	141	-	1	125	145	1	0,015	13
	134	151	-	1,1	126	159	1	0,02	17
	139	161	-	1	125	175	1	0,02	17
	139	161	165	2	129	171	2	0,025	16
	151	184	189	2,1	132	203	2	0,025	14
	165	215	-	3	134	246	2,5	0,03	14
130	140	155	-	1,1	136	159	1	0,015	16
	146	164	-	1,5	137	173	1,5	0,02	16
	154	176	-	1,1	136	192	1	0,02	16
	153	177	182	2	139	191	2	0,025	16
	161	198	-	3	144	216	2,5	0,025	15
	178	232	-	4	147	263	3	0,03	14
140	151	164	-	1,1	146	169	1	0,015	16
	156	175	-	1,5	147	183	1,5	0,02	17
	164	186	-	1,1	146	204	1	0,02	17
	163	187	192	2	149	201	2	0,025	16
	176	213	213	3	154	236	2,5	0,025	15
	191	248	248	4	157	283	3	0,03	14
150	163	177	-	1,1	156	184	1	0,015	17
	169	191	-	2	159	201	2	0,02	16
	175	199	-	1,1	156	219	1	0,02	16
	174	201	205	2,1	160	215	2	0,025	16
	191	227	-	3	164	256	2,5	0,025	15
	206	263	-	4	167	303	3	0,03	14
160	173	187	-	1,1	166	194	1	0,015	17
	179	201	-	2	169	211	2	0,02	16
	186	213	-	1,5	167	233	1,5	0,02	17
	186	214	-	2,1	169	231	2	0,025	16
	206	242	-	3	174	276	2,5	0,025	15
	219	281	-	4	177	323	3	0,03	14
170	184	201	-	1,1	176	209	1	0,015	17
	189	211	-	2	179	221	2	0,02	17
	200	229	-	1,5	177	253	1,5	0,02	16
	199	231	-	2,1	180	250	2	0,025	16
	219	259	-	4	187	293	3	0,025	15
	231	298	-	4	187	343	3	0,03	14

Single row deep groove ball bearings
d 180 – 260 mm

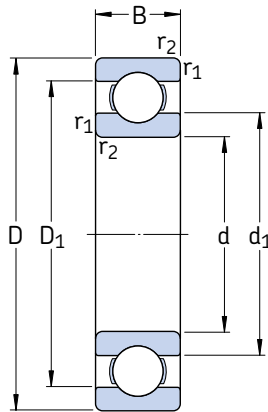

Principal dimensions			Basic load ratings		Fatigue load limit P_u	Speed ratings		Mass	Designation
d	D	B	dynamic C	static C_0		Reference speed	Limiting speed		
mm			kN		kN	r/min		kg	–
180	225	22	62,4	81,5	2,45	5 600	3 400	2,00	61836
	250	33	119	134	3,9	5 300	4 300	5,05	61936 MA
	280	31	138	146	4,15	4 800	4 000	6,60	16036
	280	46	190	200	5,6	4 800	4 000	10,5	6036 M
	320	52	229	240	6,4	4 000	3 600	18,5	6236 M
	380	75	351	405	10,4	3 600	3 200	42,5	6336 M
190	240	24	76,1	98	2,8	5 300	3 200	2,60	61838
	260	33	117	134	3,8	5 000	4 300	5,25	61938 MA
	290	31	148	166	4,55	4 800	3 000	7,90	16038
	290	46	195	216	5,85	4 800	3 800	11,0	6038 M
	340	55	255	280	7,35	3 800	3 400	23,0	6238 M
	400	78	371	430	10,8	3 400	3 000	49,0	6338 M
200	250	24	76,1	102	2,9	5 000	3 200	2,70	61840
	280	38	148	166	4,55	4 800	3 800	7,40	61940 MA
	310	34	168	190	5,1	4 300	2 800	8,85	16040
	310	51	216	245	6,4	4 300	3 600	14,0	6040 M
	360	58	270	310	7,8	3 600	3 200	28,0	6240 M
220	270	24	78	110	3	4 500	2 800	3,00	61844
	300	38	151	180	4,75	4 300	3 600	8,00	61944 MA
	340	37	174	204	5,2	4 000	2 400	11,5	16044
	340	56	247	290	7,35	4 000	3 200	18,5	6044 M
	400	65	296	365	8,8	3 200	3 000	37,0	6244 M
	460	88	410	520	12	3 000	2 600	72,5	6344 M
240	300	28	108	150	3,8	4 000	2 600	4,50	61848
	320	38	159	200	5,1	4 000	3 200	8,60	61948 MA
	360	37	178	220	5,3	3 600	3 000	14,5	16048 MA
	360	56	255	315	7,8	3 600	3 000	19,5	6048 M
	440	72	358	465	10,8	3 000	2 600	51,0	6248 M
	500	95	442	585	12,9	2 600	2 400	92,5	6348 M
260	320	28	111	163	4	3 800	2 400	4,80	61852
	360	46	212	270	6,55	3 600	3 000	14,5	61952 MA
	400	44	238	310	7,2	3 200	2 800	21,5	16052 MA
	400	65	291	375	8,8	3 200	2 800	29,5	6052 M
	480	80	390	530	11,8	2 600	2 400	65,5	6252 M

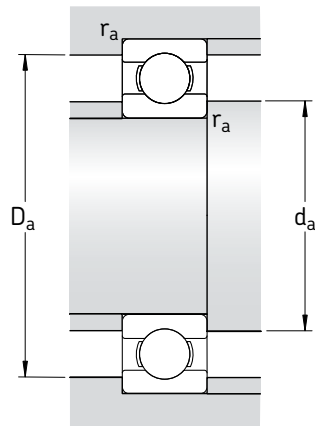

Dimensions			Abutment and fillet dimensions				Calculation factors	
d	d ₁ ~	D ₁ ~	r _{1,2} min	d _a min	D _a max	r _a max	k _r	f ₀
mm			mm				-	
180	194	211	1,1	186	219	1	0,015	17
	203	227	2	189	241	2	0,02	16
	214	246	2	189	271	2	0,02	16
	212	248	2,1	190	270	2	0,025	16
	227	273	4	197	303	3	0,025	15
	245	314	4	197	363	3	0,03	14
190	206	224	1,5	197	233	1,5	0,015	17
	213	237	2	199	251	2	0,02	17
	224	255	2	199	281	2	0,02	16
	222	258	2,1	200	280	2	0,025	16
	240	290	4	207	323	3	0,025	15
	259	331	5	210	380	4	0,03	14
200	216	234	1,5	207	243	1,5	0,015	17
	226	254	2,1	210	270	2	0,02	16
	237	272	2	209	301	2	0,02	16
	235	275	2,1	210	300	2	0,025	16
	255	302	4	217	343	3	0,025	15
	220	236	254	1,5	227	263	1,5	0,015
246		274	2,1	230	290	2	0,02	17
262		298	2,1	230	330	2	0,02	16
258		302	3	233	327	2,5	0,025	16
283		335	4	237	383	3	0,025	15
300		381	5	240	440	4	0,03	14
240	259	281	2	249	291	2	0,015	17
	266	294	2,1	250	310	2	0,02	17
	280	320	2,1	250	350	2	0,02	17
	278	322	3	253	347	2,5	0,025	16
	308	373	4	257	423	3	0,025	15
	330	411	5	260	480	4	0,03	15
260	279	301	2	269	311	2	0,015	17
	292	328	2,1	270	350	2	0,02	16
	307	352	3	273	387	2,5	0,02	16
	305	355	4	277	383	3	0,025	16
	336	405	5	280	460	4	0,025	15

Single row deep groove ball bearings
d 280 – 420 mm

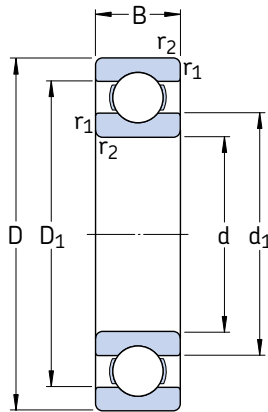

Principal dimensions			Basic load ratings		Fatigue load limit P_u	Speed ratings		Mass	Designation
d	D	B	dynamic C	static C_0		Reference speed	Limiting speed		
mm			kN		kN	r/min		kg	–
280	350	33	138	200	4,75	3 400	2 200	7,40	61856
	380	46	216	285	6,7	3 200	2 800	15,0	61956 MA
	420	44	242	335	7,5	3 000	2 600	23,0	16056 MA
	420	65	302	405	9,3	3 000	2 600	31,0	6056 M
	500	80	423	600	12,9	2 600	2 200	71,0	6256 M
300	380	38	172	245	5,6	3 200	2 600	10,5	61860 MA
	420	56	270	375	8,3	3 000	2 400	24,5	61960 MA
	460	50	286	405	8,8	2 800	2 400	32,0	16060 MA
	460	74	358	500	10,8	2 800	2 400	44,0	6060 M
	540	85	462	670	13,7	2 400	2 000	88,5	6260 M
320	400	38	172	255	5,7	3 000	2 400	11,0	61864 MA
	440	56	276	400	8,65	2 800	2 400	25,5	61964 MA
	480	50	281	405	8,65	2 600	2 200	34,0	16064 MA
	480	74	371	540	11,4	2 600	2 200	46,0	6064 M
340	420	38	178	275	6	2 800	2 400	11,5	61868 MA
	460	56	281	425	9	2 600	2 200	26,5	61968 MA
	520	57	345	520	10,6	2 400	2 000	45,0	16068 MA
	520	82	423	640	13,2	2 400	2 000	62,0	6068 M
360	440	38	182	285	6,1	2 600	2 200	12,0	61872 MA
	480	56	291	450	9,15	2 600	2 000	28,0	61972 MA
	540	57	351	550	11	2 400	1 900	49,0	16072 MA
	540	82	462	735	15	2 400	1 900	64,5	6072 M
380	480	46	242	390	8	2 400	2 000	20,0	61876 MA
	520	65	338	540	10,8	2 400	1 900	40,0	61976 MA
	560	57	377	620	12,2	2 200	1 800	51,0	16076 MA
	560	82	462	750	14,6	2 200	1 800	67,5	6076 M
400	500	46	247	405	8,15	2 400	1 900	20,5	61880 MA
	540	65	345	570	11,2	2 200	1 800	41,5	61980 MA
	600	90	520	865	16,3	2 000	1 700	87,5	6080 M
420	520	46	251	425	8,3	2 200	1 800	21,5	61884 MA
	560	65	351	600	11,4	2 200	1 800	43,0	61984 MA
	620	90	507	880	16,3	2 000	1 600	91,5	6084 M

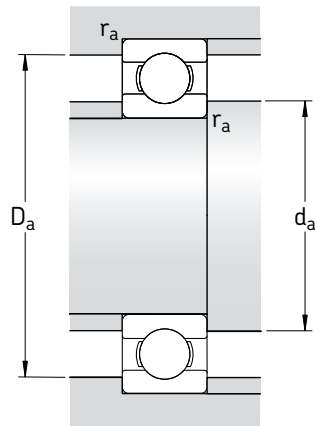

Dimensions			Abutment and fillet dimensions				Calculation factors	
d	d ₁	D ₁	r _{1,2}	d _a	D _a	r _a	k _r	f ₀
mm			mm				-	
280	302	327	2	289	341	2	0,015	17
	312	348	2,1	291	369	2	0,02	17
	326	374	3	293	407	2,5	0,02	17
	325	375	4	296	404	3	0,025	16
	353	427	5	300	480	4	0,025	15
300	326	354	2,1	309	371	2	0,015	17
	338	382	3	313	407	2,5	0,02	16
	352	408	4	315	445	3	0,02	16
	350	410	4	315	445	3	0,025	16
	381	459	5	320	520	4	0,025	15
320	346	374	2,1	332	388	2	0,015	17
	358	402	3	333	427	2,5	0,02	16
	372	428	4	335	465	3	0,02	17
	370	431	4	335	465	3	0,025	16
340	366	394	2,1	352	408	2	0,015	17
	378	423	3	353	447	2,5	0,02	17
	398	462	4	355	505	3	0,02	16
	396	462	5	360	500	4	0,025	16
360	385	416	2,1	372	428	2	0,015	17
	398	442	3	373	467	2,5	0,02	17
	418	482	4	375	525	3	0,02	16
	416	485	5	378	522	4	0,025	16
380	412	449	2,1	392	468	2	0,015	17
	425	475	4	395	505	3	0,02	17
	438	502	4	395	545	3	0,02	17
	436	502	5	398	542	4	0,025	16
400	432	471	2,1	412	488	2	0,015	17
	445	495	4	415	525	3	0,02	17
	462	536	5	418	582	4	0,025	16
420	452	491	2,1	432	508	2	0,015	17
	465	515	4	435	545	3	0,02	17
	482	558	5	438	602	4	0,025	16

Single row deep groove ball bearings
d 440 – 710 mm

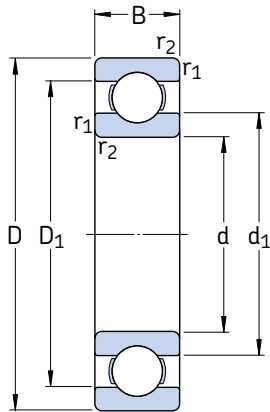

Principal dimensions			Basic load ratings		Fatigue load limit P_u	Speed ratings		Mass	Designation
d	D	B	dynamic C	static C_0		Reference speed	Limiting speed		
mm			kN		kN	r/min		kg	–
440	540	46	255	440	8,5	2 200	1 800	22,5	61888 MA
	600	74	410	720	13,2	2 000	1 600	60,5	61988 MA
	650	94	553	965	17,6	1 900	1 500	105	6088 M
460	580	56	319	570	10,6	2 000	1 600	35,0	61892 MA
	620	74	423	750	13,7	1 900	1 600	62,5	61992 MA
	680	100	582	1 060	19	1 800	1 500	120	6092 MB
480	600	56	325	600	10,8	1 900	1 600	36,5	61896 MA
	650	78	449	815	14,6	1 800	1 500	74,0	61996 MA
	700	100	618	1 140	20	1 700	1 400	125	6096 MB
500	620	56	332	620	11,2	1 800	1 500	40,5	618/500 MA
	670	78	462	865	15	1 700	1 400	77,0	619/500 MA
	720	100	605	1 140	19,6	1 600	1 300	135	60/500 N1MAS
530	650	56	332	655	11,2	1 700	1 400	39,5	618/530 MA
	710	82	488	930	15,6	1 600	1 300	90,5	619/530 MA
	780	112	650	1 270	20,8	1 500	1 200	185	60/530 N1MAS
560	680	56	345	695	11,8	1 600	1 300	42,0	618/560 MA
	750	85	494	980	16,3	1 500	1 200	105	619/560 MA
	820	115	663	1 470	22	1 400	1 200	210	60/560 N1MAS
600	730	60	364	765	12,5	1 500	1 200	52,0	618/600 MA
	800	90	585	1 220	19,6	1 400	1 100	125	619/600 MA
630	780	69	442	965	15,3	1 400	1 100	73,0	618/630 MA
	850	100	624	1 340	21,2	1 300	1 100	160	619/630 N1MA
	920	128	819	1 760	27	1 200	1 000	285	60/630 N1MBS
670	820	69	442	1 000	15,6	1 300	1 100	83,5	618/670 MA
	900	103	676	1 500	22,4	1 200	1 000	185	619/670 MA
	980	136	904	2 040	30	1 100	900	345	60/670 N1MAS
710	870	74	475	1 100	16,6	1 200	1 000	93,5	618/710 MA
	950	106	663	1 500	22	1 100	900	220	619/710 MA
	1 030	140	956	2 200	31,5	1 000	850	375	60/710 MA

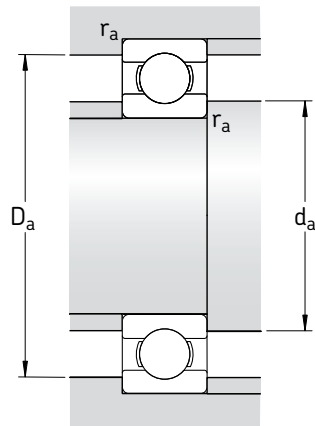

Dimensions			Abutment and fillet dimensions				Calculation factors	
d	d ₁	D ₁	r _{1,2}	d _a	D _a	r _a	k _r	f ₀
mm			mm				-	
440	472	510	2,1	452	528	2	0,015	17
	492	548	4	455	585	3	0,02	17
	505	586	6	463	627	5	0,025	16
460	498	542	3	473	567	2,5	0,015	17
	512	568	4	476	604	3	0,02	17
	528	614	6	483	657	5	0,025	16
480	518	564	3	493	587	2,5	0,015	17
	535	595	5	498	632	4	0,02	17
	548	630	6	503	677	5	0,025	16
500	538	582	3	513	607	2,5	0,015	17
	555	615	5	518	652	4	0,02	17
	568	650	6	523	697	5	0,025	16
530	568	614	3	543	637	2,5	0,015	17
	587	653	5	548	692	4	0,02	17
	613	697	6	553	757	5	0,025	16
560	598	644	3	573	667	2,5	0,015	17
	622	688	5	578	732	4	0,02	17
	648	732	6	583	797	5	0,025	16
600	642	688	3	613	717	2,5	0,015	17
	664	736	5	618	782	4	0,02	17
630	678	732	4	645	765	3	0,015	17
	702	778	6	653	827	5	0,02	17
	725	825	7,5	658	892	6	0,025	16
670	718	772	4	685	805	3	0,015	17
	745	825	6	693	877	5	0,02	17
	772	878	7,5	698	952	6	0,025	16
710	761	819	4	725	855	3	0,015	17
	790	870	6	733	927	5	0,02	17
	813	927	7,5	738	1002	6	0,025	16

Single row deep groove ball bearings
d 750 – 1 500 mm

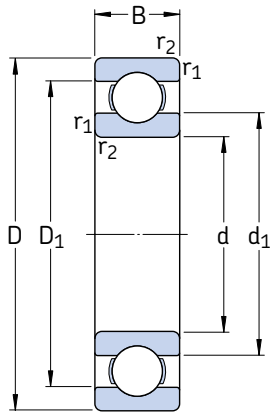

Principal dimensions			Basic load ratings		Fatigue load limit P_u	Speed ratings		Mass	Designation
d	D	B	dynamic C	static C_0		Reference speed	Limiting speed		
mm			kN		kN	r/min		kg	–
750	920	78	527	1 250	18,3	1 100	900	110	618/750 MA
	1 000	112	761	1 800	25,5	1 000	850	255	619/750 MA
800	980	82	559	1 370	19,3	1 000	850	130	618/800 MA
	1 060	115	832	2 040	28,5	950	800	275	619/800 MA
	1 150	155	1 010	2 550	34,5	900	750	535	60/800 N1MAS
850	1 030	82	559	1 430	19,6	950	750	140	618/850 MA
900	1 090	85	618	1 600	21,6	850	700	160	618/900 MA
1 000	1 220	100	637	1 800	22,8	750	600	245	618/1000 MA
1 060	1 280	100	728	2 120	26,5	670	560	260	618/1060 MA
1 120	1 360	106	741	2 200	26,5	630	530	315	618/1120 MA
1 180	1 420	106	761	2 360	27,5	560	480	330	618/1180 MB
1 500	1 820	140	1 210	4 400	46,5	380	240	690	618/1500 TN

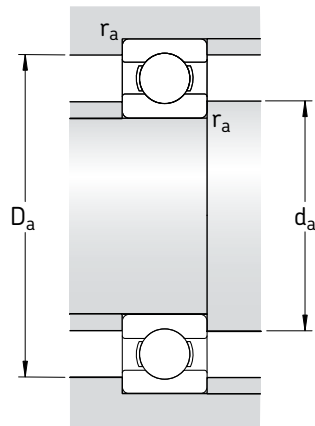

Dimensions				Abutment and fillet dimensions			Calculation factors	
d	d ₁ ~	D ₁ ~	r _{1,2} min	d _a min	D _a max	r _a max	k _r	f ₀
mm				mm			-	
750	804	866	5	768	902	4	0,015	17
	835	915	6	773	977	5	0,02	17
800	857	923	5	818	962	4	0,015	17
	884	976	6	823	1 037	5	0,02	17
	918	1 032	7,5	828	1 122	6	0,025	16
850	907	973	5	868	1 012	4	0,015	17
900	961	1 030	5	918	1 072	4	0,015	17
1 000	1 076	1 145	6	1 023	1 197	5	0,015	17
1 060	1 132	1 209	6	1 083	1 257	5	0,015	17
1 120	1 202	1 278	6	1 143	1 337	5	0,015	17
1 180	1 262	1 339	6	1 203	1 397	5	0,015	17
1 500	1 607	1 714	7,5	1 528	1 792	6	0,015	17

Sealed single row deep groove ball bearings

d 3 – 7 mm

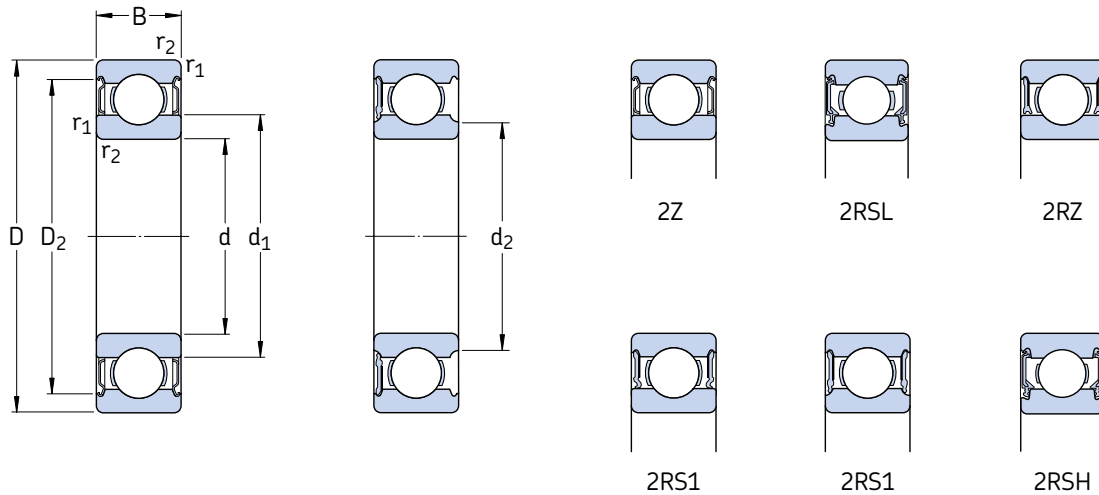

Principal dimensions			Basic load ratings		Fatigue load limit P_u	Speed ratings		Mass	Designations	
d	D	B	dynamic C	static C_0		Reference speed	Limiting speed ¹⁾		Bearing sealed on both sides	one side
mm			kN		kN	r/min		kg	–	
3	10	4	0,54	0,18	0,007	130 000	60 000	0,0015 (193)	623-2Z	623-Z
	10	4	0,54	0,18	0,007	–	40 000	0,0015	623-2RS1	623-RS1
4	9	3,5	0,54	0,18	0,007	140 000	70 000	0,0010	628/4-2Z	–
	9	4	0,54	0,18	0,007	140 000	70 000	0,0013	638/4-2Z	–
	11	4	0,72	0,23	0,010	130 000	63 000	0,0017	619/4-2Z	–
	12	4	0,81	0,28	0,012	120 000	60 000	0,0021	604-2Z	604-Z
	13	5	0,94	0,29	0,012	110 000	53 000	0,0031 (207)	624-2Z	624-Z
	16	5	1,11	0,38	0,016	95 000	48 000	0,0054	634-2Z	634-Z
5	16	5	1,11	0,38	0,016	95 000	48 000	0,0054	634-2RZ	634-RZ
	16	5	1,11	0,38	0,016	–	28 000	0,0054	634-2RS1	634-RS1
	11	4	0,64	0,26	0,011	120 000	60 000	0,0014	628/5-2Z	–
	11	5	0,64	0,26	0,011	120 000	60 000	0,0016	638/5-2Z	–
	13	4	0,88	0,34	0,014	110 000	53 000	0,0025	619/5-2Z	–
	16	5	1,14	0,38	0,016	95 000	48 000	0,005 (161)	* 625-2Z	* 625-Z
6	19	6	2,34	0,95	0,04	80 000	40 000	0,009	* 635-2Z	* 635-Z
	19	6	2,34	0,95	0,04	80 000	40 000	0,009	* 635-2RZ	* 635-RZ
	19	6	2,34	0,95	0,04	–	24 000	0,009	* 635-2RS1	* 635-RS1
7	13	5	0,88	0,35	0,015	110 000	53 000	0,0026	628/6-2Z	–
	15	5	1,24	0,48	0,02	100 000	50 000	0,0039	619/6-2Z	–
	19	6	2,34	0,95	0,04	80 000	40 000	0,0084 (131)	* 626-2Z	* 626-Z
	19	6	2,34	0,95	0,04	80 000	40 000	0,0084	* 626-2RSL	* 626-RSL
	19	6	2,34	0,95	0,04	–	24 000	0,0084 (223)	* 626-2RSH	* 626-RSH
	14	5	0,956	0,4	0,017	100 000	50 000	0,0031	628/7-2Z	–
7	17	5	1,48	0,56	0,024	90 000	45 000	0,0049	619/7-2Z	–
	19	6	2,34	0,95	0,04	85 000	43 000	0,0075	* 607-2Z	* 607-Z
	19	6	2,34	0,95	0,04	85 000	43 000	0,0075	* 607-2RSL	* 607-RSL
	19	6	2,34	0,95	0,04	–	24 000	0,0075	* 607-2RSH	* 607-RSH
	22	7	3,45	1,37	0,057	70 000	36 000	0,013 (137)	* 627-2Z	* 627-Z
	22	7	3,45	1,37	0,057	70 000	36 000	0,012	* 627-2RSL	* 627-RSL
	22	7	3,45	1,37	0,057	–	22 000	0,012 (250)	* 627-2RSH	* 627-RSH

* SKF Explorer bearing

¹⁾ For bearings with only one shield or low-friction seal (Z, RZ, RSL), the limiting speeds for open bearings are valid

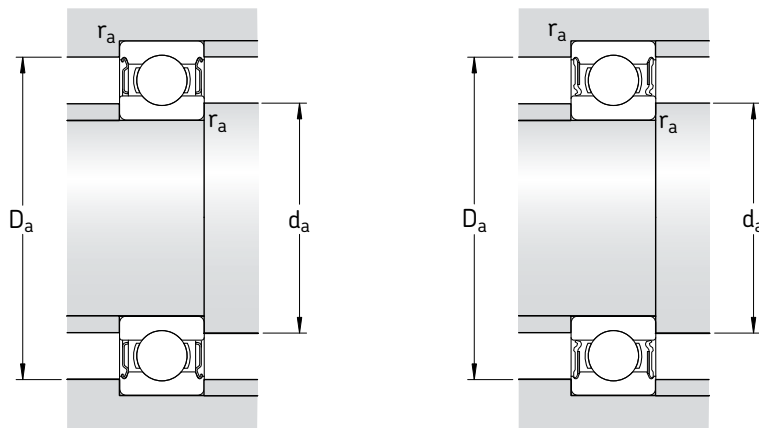

Dimensions					Abutment and fillet dimensions				Calculation factors		
d	d ₁ ~	d ₂ ~	D ₂ ~	r _{1,2} min	d _a min	d _a max	D _a max	r _a max	k _r	f ₀	
mm					mm				-		
3	5,2	-	8,2	0,15	4,2	-	8,8	0,1	0,025	7,5	
	5,2	-	8,2	0,15	4,2	-	8,8	0,1	0,025	7,5	
4	5,2	-	7,8	0,1	4,6	-	8,4	0,1	0,015	10	
	5,2	-	7,8	0,1	4,6	-	8,4	0,1	0,015	10	
	5,9	-	9,8	0,15	4,8	-	10,2	0,1	0,02	9,9	
	6,1	-	9,8	0,2	5,4	-	10,6	0,2	0,025	10	
	6,7	-	11,2	0,2	5,8	-	11,2	0,2	0,025	7,3	
	8,4	-	13,3	0,3	6,4	-	13,6	0,3	0,03	8,4	
	8,4	-	13,3	0,3	6,4	-	13,6	0,3	0,03	8,4	
	8,4	-	13,3	0,3	6,4	-	13,6	0,3	0,03	8,4	
	5	6,8	-	9,7	0,15	5,8	-	10,2	0,1	0,015	11
		6,8	-	9,7	0,15	5,8	-	10,2	0,1	0,015	11
7,6		-	11,4	0,2	6,4	-	11,6	0,2	0,02	11	
8,4		-	13,3	0,3	7,4	-	13,6	0,3	0,025	8,4	
10,7		-	16,5	0,3	7,4	-	16,6	0,3	0,03	13	
10,7		-	16,5	0,3	7,4	-	16,6	0,3	0,03	13	
10,7		-	16,5	0,3	7,4	-	16,6	0,3	0,03	13	
6	7,9	-	11,7	0,15	6,8	-	12,2	0,1	0,015	11	
	8,6	-	13,3	0,2	7,4	-	13,6	0,2	0,02	10	
	11,1	-	16,5	0,3	8,4	-	16,6	0,3	0,025	13	
	-	9,5	16,5	0,3	8,4	9,4	16,6	0,3	0,025	13	
	-	9,5	16,5	0,3	8,4	9,4	16,6	0,3	0,025	13	
	-	9,5	16,5	0,3	8,4	9,4	16,6	0,3	0,025	13	
7	8,9	-	12,6	0,15	7,8	-	13,2	0,1	0,015	11	
	9,8	-	15,2	0,3	9	-	15	0,3	0,02	10	
	11,1	-	16,5	0,3	9	-	17	0,3	0,025	13	
	-	9,5	16,5	0,3	9	9,4	17	0,3	0,025	13	
	-	9,5	16,5	0,3	9	9,4	17	0,3	0,025	13	
	12,2	-	19,2	0,3	9,4	-	19,6	0,3	0,025	12	
	-	10,6	19,2	0,3	9,4	10,5	19,6	0,3	0,025	12	
	-	10,6	19,2	0,3	9,4	10,5	19,6	0,3	0,025	12	

Sealed single row deep groove ball bearings

d 8 – 9 mm

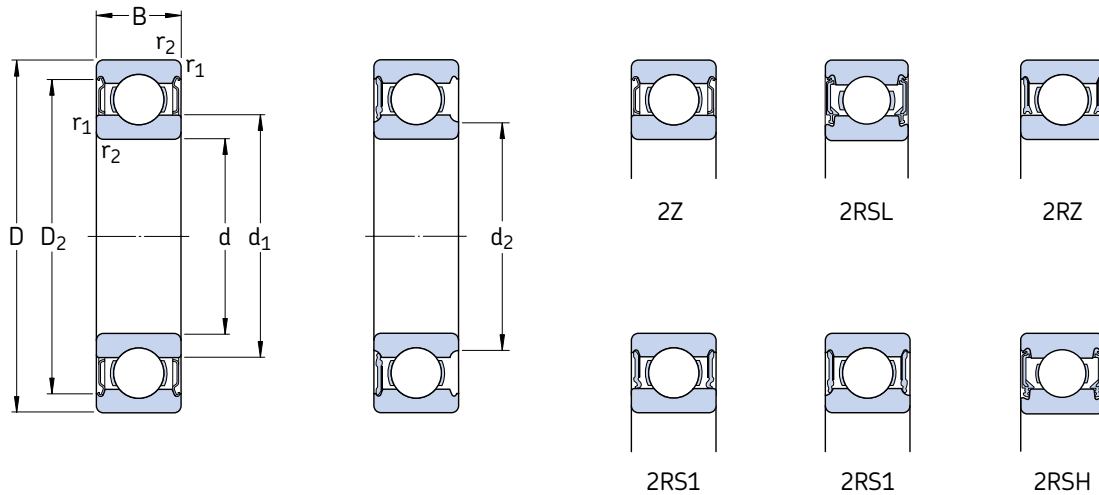

Principal dimensions			Basic load ratings		Fatigue load limit P_u	Speed ratings		Mass	Designations	
d	D	B	dynamic	static		Reference speed	Limiting speed ¹⁾		Bearing sealed on both sides	one side
mm			kN		kN	r/min		kg	–	
8	16	5	1,33	0,57	0,024	90 000	45 000	0,0036 (585)	628/8-2Z	–
	16	5	1,33	0,57	0,024	–	26 000	0,0036	628/8-2RS1	–
	16	6	1,33	0,57	0,024	90 000	45 000	0,0043	638/8-2Z	–
	19	6	1,9	0,74	0,031	80 000	40 000	0,0071	619/8-2Z	–
	19	6	1,9	0,74	0,031	–	24 000	0,0071	619/8-2RS1	–
	19	6	2,21	0,95	0,04	85 000	43 000	0,0072	607/8-2Z	607/8-Z
	22	7	3,45	1,37	0,057	75 000	38 000	0,012	* 608-2Z	* 608-Z
	22	7	3,45	1,37	0,057	75 000	38 000	0,012	* 608-2RSL	* 608-RSL
	22	7	3,45	1,37	0,057	–	22 000	0,012	* 608-2RSH	* 608-RSH
	22	11	3,45	1,37	0,057	–	22 000	0,016	630/8-2RS1	–
	24	8	3,9	1,66	0,071	63 000	32 000	0,017	* 628-2Z	* 628-Z
	24	8	3,9	1,66	0,071	63 000	32 000	0,017	* 628-2RZ	* 628-RZ
24	8	3,9	1,66	0,071	–	19 000	0,017	* 628-2RS1	* 628-RS1	
28	9	4,62	1,96	0,083	60 000	30 000	0,030	638-2RZ	638-RZ	
9	17	5	1,43	0,64	0,027	85 000	43 000	0,0043	628/9-2Z	628/9-Z
	17	5	1,43	0,64	0,027	–	24 000	0,0043	628/9-2RS1	–
	20	6	2,08	0,87	0,036	80 000	38 000	0,0076	619/9-2Z	–
	24	7	3,9	1,66	0,071	70 000	34 000	0,014	* 609-2Z	* 609-Z
	24	7	3,9	1,66	0,071	70 000	34 000	0,014	* 609-2RSL	* 609-RSL
	24	7	3,9	1,66	0,071	–	19 000	0,014	* 609-2RSH	* 609-RSH
	26	8	4,75	1,96	0,083	60 000	30 000	0,020	* 629-2Z	* 629-Z
	26	8	4,75	1,96	0,083	60 000	30 000	0,020	* 629-2RSL	* 629-RSL
	26	8	4,75	1,96	0,083	–	19 000	0,020 (237)	* 629-2RSH	* 629-RSH

* SKF Explorer bearing

¹⁾ For bearings with only one shield or low-friction seal (Z, RZ, RSL), the limiting speeds for open bearings are valid

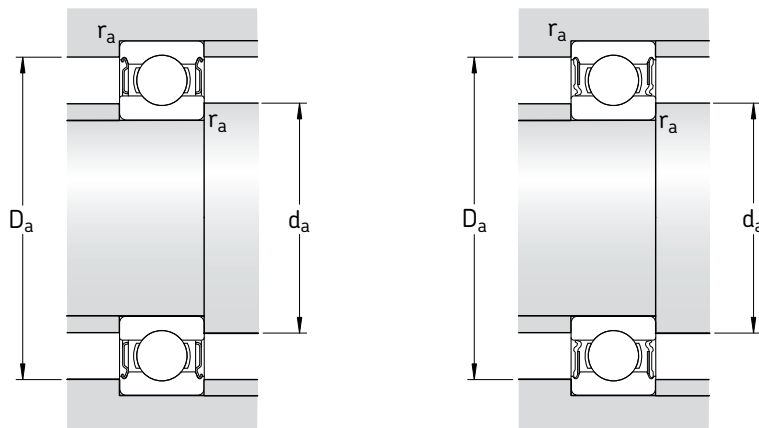

Dimensions					Abutment and fillet dimensions				Calculation factors	
d	d ₁	d ₂	D ₂	r _{1,2} min	d _a min	d _a max	D _a max	r _a max	k _r	f ₀
mm					mm				-	
8	10,1	-	14,5	0,2	9,4	-	14,6	0,2	0,015	11
	-	9,5	14,5	0,2	9,4	9,4	14,6	0,2	0,015	11
	10,1	-	14,5	0,2	9,4	-	14,6	0,2	0,015	11
	11,1	-	17	0,3	10	-	17	0,3	0,02	10
	-	10,4	17	0,3	10	10	17	0,3	0,02	10
	11,1	-	16,5	0,3	10	-	17	0,3	0,025	13
	12,1	-	19,2	0,3	10	-	20	0,3	0,025	12
	-	10,6	19,2	0,3	10	10,5	20	0,3	0,025	12
	-	10,6	19,2	0,3	10	10,5	20	0,3	0,025	12
	11,8	-	19	0,3	10	-	20	0,3	0,025	12
	14,5	-	20,6	0,3	10,4	-	21,6	0,3	0,025	13
	14,5	-	20,6	0,3	10,4	-	21,6	0,3	0,025	13
14,5	-	20,6	0,3	10,4	-	21,6	0,3	0,025	13	
14,8	-	22,6	0,3	10,4	-	25,6	0,3	0,03	12	
9	11,1	-	15,5	0,2	10,4	-	15,6	0,2	0,015	11
	-	10,6	15,5	0,2	10,4	10,5	15,6	0,2	0,015	11
	12	-	17,9	0,3	11	-	18	0,3	0,02	11
	14,4	-	21,2	0,3	11	-	22	0,3	0,025	13
	-	12,8	21,2	0,3	11	12,5	22	0,3	0,025	13
	-	12,8	21,2	0,3	11	12,5	22	0,3	0,025	13
	14,8	-	22,6	0,3	11,4	-	23,6	0,3	0,025	12
	-	13	22,6	0,3	11,4	12,5	23,6	0,3	0,025	12
	-	13	22,6	0,3	11,4	12,5	23,6	0,3	0,025	12

Sealed single row deep groove ball bearings

d 10 – 12 mm

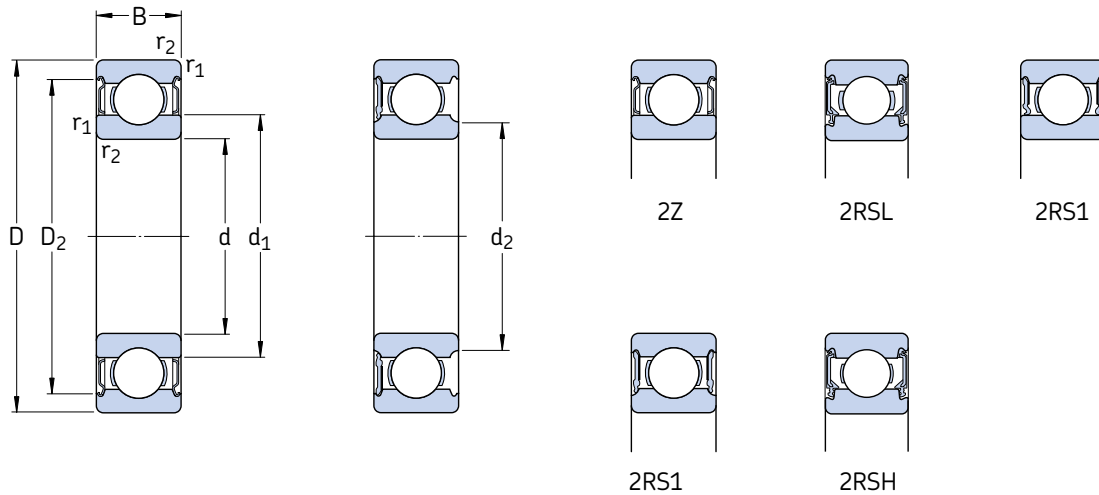

Principal dimensions			Basic load ratings		Fatigue load limit P_u	Speed ratings		Mass	Designations	
d	D	B	dynamic C	static C_0		Reference speed	Limiting speed ¹⁾		Bearing sealed on both sides	one side
mm			kN		kN	r/min		kg	–	
10	19	5	1,38	0,59	0,025	80 000	38 000	0,0055	61800-2Z	–
	19	5	1,38	0,59	0,025	–	22 000	0,0055	61800-2RS1	–
	22	6	2,08	0,85	0,036	75 000	36 000	0,010	61900-2Z	–
	22	6	2,08	0,85	0,036	–	20 000	0,010	61900-2RS1	–
	26	8	4,75	1,96	0,083	67 000	34 000	0,019	* 6000-2Z	* 6000-Z
	26	8	4,75	1,96	0,083	67 000	34 000	0,019	* 6000-2RSL	* 6000-RSL
	26	8	4,75	1,96	0,083	–	19 000	0,019	* 6000-2RSH	* 6000-RSH
	26	12	4,62	1,96	0,083	–	19 000	0,025	63000-2RS1	–
	28	8	4,62	1,96	0,083	63 000	32 000	0,022	16100-2Z	–
	30	9	5,4	2,36	0,1	56 000	28 000	0,032	* 6200-2Z	* 6200-Z
	30	9	5,4	2,36	0,1	56 000	28 000	0,032	* 6200-2RSL	* 6200-RSL
	30	9	5,4	2,36	0,1	–	17 000	0,032	* 6200-2RSH	* 6200-RSH
	30	14	5,07	2,36	0,1	–	17 000	0,04	62200-2RS1	–
	35	11	8,52	3,4	0,143	50 000	26 000	0,053	* 6300-2Z	* 6300-Z
	35	11	8,52	3,4	0,143	50 000	26 000	0,053	* 6300-2RSL	* 6300-RSL
	35	11	8,52	3,4	0,143	–	15 000	0,053	* 6300-2RSH	* 6300-RSH
35	17	8,06	3,4	0,143	–	15 000	0,06	62300-2RS1	–	
12	21	5	1,43	0,67	0,028	70 000	36 000	0,0063	61801-2Z	–
	21	5	1,43	0,67	0,028	–	20 000	0,0063	61801-2RS1	–
	24	6	2,25	0,98	0,043	67 000	32 000	0,011	61901-2Z	–
	24	6	2,25	0,98	0,043	–	19 000	0,011	61901-2RS1	–
	28	8	5,4	2,36	0,1	60 000	30 000	0,022	* 6001-2Z	* 6001-Z
	28	8	5,4	2,36	0,1	60 000	30 000	0,022	* 6001-2RSL	* 6001-RSL
	28	8	5,4	2,36	0,1	–	17 000	0,022	* 6001-2RSH	* 6001-RSH
	28	12	5,07	2,36	0,1	–	17 000	0,029	63001-2RS1	–
	30	8	5,07	2,36	0,1	56 000	28 000	0,023	16101-2Z	–
	30	8	5,07	2,36	0,1	–	16 000	0,023	16101-2RS1	–
	32	10	7,28	3,1	0,132	50 000	26 000	0,037	* 6201-2Z	* 6201-Z
	32	10	7,28	3,1	0,132	50 000	26 000	0,037	* 6201-2RSL	* 6201-RSL
	32	10	7,28	3,1	0,132	–	15 000	0,037	* 6201-2RSH	* 6201-RSH
	32	14	6,89	3,1	0,132	–	15 000	0,045	62201-2RS1	–
	37	12	10,1	4,15	0,176	45 000	22 000	0,060	* 6301-2Z	* 6301-Z
	37	12	10,1	4,15	0,176	45 000	22 000	0,060	* 6301-2RSL	* 6301-RSL
37	12	10,1	4,15	0,176	–	14 000	0,060	* 6301-2RSH	* 6301-RSH	
37	17	9,75	4,15	0,176	–	14 000	0,070	62301-2RS1	–	

* SKF Explorer bearing

¹⁾ For bearings with only one shield or low-friction seal (Z, RSL), the limiting speeds for open bearings are valid

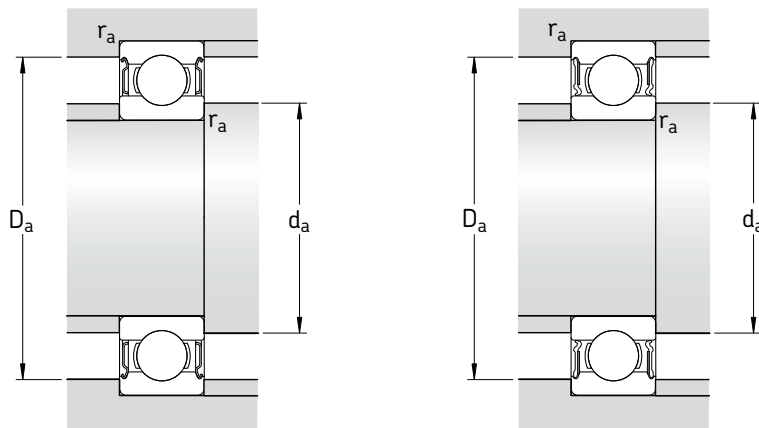

Dimensions					Abutment and fillet dimensions				Calculation factors	
d	d ₁	d ₂	D ₂	r _{1,2} min	d _a min	d _a max	D _a max	r _a max	k _r	f ₀
mm					mm				-	
10	12,6	-	17,3	0,3	12	-	17	0,3	0,015	9,4
	-	11,8	17,3	0,3	11,8	11,8	17	0,3	0,015	9,4
	13	-	19	0,3	12	-	20	0,3	0,02	9,3
	-	12	19	0,3	12	12	20	0,3	0,02	9,3
	14,8	-	22,6	0,3	12	-	24	0,3	0,025	12
	-	13	22,6	0,3	12	12,5	24	0,3	0,025	12
	-	13	22,6	0,3	12	12,5	24	0,3	0,025	12
	14,8	-	22,6	0,3	12	-	24	0,3	0,025	12
	16,7	-	24,8	0,6	14,2	-	23,8	0,3	0,025	13
	17	-	24,8	0,6	14,2	-	25,8	0,6	0,025	13
	-	15,2	24,8	0,6	14,2	15	25,8	0,6	0,025	13
	-	15,2	24,8	0,6	14,2	15	25,8	0,6	0,025	13
	17	-	24,8	0,6	14,2	-	25,8	0,6	0,025	13
	17,5	-	28,7	0,6	14,2	-	30,8	0,6	0,03	11
	-	15,7	28,7	0,6	14,2	15,5	30,8	0,6	0,03	11
	-	15,7	28,7	0,6	14,2	15,5	30,8	0,6	0,03	11
17,5	-	28,7	0,6	14,2	-	30,8	0,6	0,03	11	
12	15	-	19,1	0,3	14	-	19	0,3	0,015	9,7
	-	14,1	19,1	0,3	14	14	19	0,3	0,015	9,7
	15,5	-	21,4	0,3	14	-	22	0,3	0,02	9,7
	15,5	-	21,4	0,3	14	-	22	0,3	0,02	9,7
	17	-	24,8	0,3	14	-	26	0,3	0,025	13
	-	15,2	24,8	0,3	14	15	26	0,3	0,025	13
	-	15,2	24,8	0,3	14	15	26	0,3	0,025	13
	17	-	24,8	0,3	14	-	26	0,3	0,025	13
	16,7	-	24,8	0,3	14,4	-	27,6	0,3	0,025	13
	16,7	-	24,8	0,3	14,4	-	27,6	0,3	0,025	13
	18,5	-	27,4	0,6	16,2	-	27,8	0,6	0,025	12
	-	16,6	27,4	0,6	16,2	16,5	27,8	0,6	0,025	12
	-	16,6	27,4	0,6	16,2	16,5	27,8	0,6	0,025	12
	18,5	-	27,4	0,6	16,2	-	27,8	0,6	0,025	12
	19,5	-	31,5	1	17,6	-	31,4	1	0,03	11
	-	17,7	31,5	1	17,6	17,6	31,4	1	0,03	11
	-	17,7	31,5	1	17,6	17,6	31,4	1	0,03	11
	19,5	-	31,5	1	17,6	-	31,4	1	0,03	11

Sealed single row deep groove ball bearings

d 15 – 17 mm

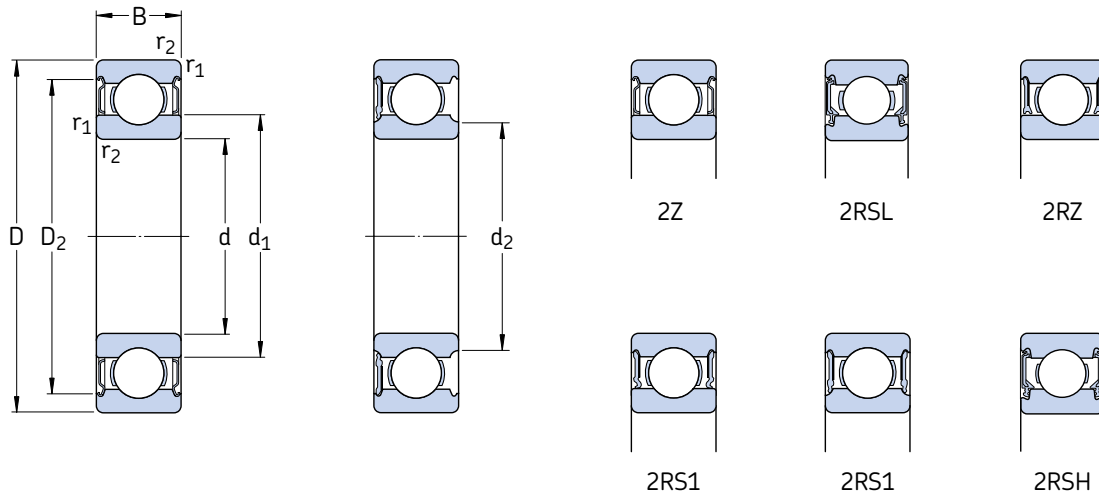

Principal dimensions			Basic load ratings		Fatigue load limit P_u	Speed ratings		Mass	Designations	
d	D	B	C	C_0		Reference speed	Limiting speed ¹⁾		Bearing sealed on both sides	one side
mm			kN		kN	r/min		kg	–	
15	24	5	1,56	0,8	0,034	60 000	30 000	0,0074	61802-2Z	–
	24	5	1,56	0,8	0,034	–	17 000	0,0074	61802-2RS1	–
	28	7	4,36	2,24	0,095	56 000	28 000	0,016	61902-2Z	–
	28	7	4,36	2,24	0,095	56 000	28 000	0,016	61902-2RZ	–
	28	7	4,36	2,24	0,095	–	16 000	0,016	61902-2RS1	–
	32	8	5,85	2,85	0,12	50 000	26 000	0,025	* 16002-2Z	* 16002-Z
	32	9	5,85	2,85	0,12	50 000	26 000	0,030	* 6002-2Z	* 6002-Z
	32	9	5,85	2,85	0,12	50 000	26 000	0,030	* 6002-2RSL	* 6002-RSL
	32	9	5,85	2,85	0,12	–	14 000	0,030	* 6002-2RSH	* 6002-RSH
	32	13	5,59	2,85	0,12	–	14 000	0,039	63002-2RS1	–
	35	11	8,06	3,75	0,16	43 000	22 000	0,045	* 6202-2Z	* 6202-Z
	35	11	8,06	3,75	0,16	43 000	22 000	0,045	* 6202-2RSL	* 6202-RSL
	35	11	8,06	3,75	0,16	–	13 000	0,045	* 6202-2RSH	* 6202-RSH
	35	14	7,8	3,75	0,16	–	13 000	0,054	62202-2RS1	–
	42	13	11,9	5,4	0,228	38 000	19 000	0,082	* 6302-2Z	* 6302-Z
	42	13	11,9	5,4	0,228	38 000	19 000	0,082	* 6302-2RSL	* 6302-RSL
	42	13	11,9	5,4	0,228	–	12 000	0,082	* 6302-2RSH	* 6302-RSH
	42	17	11,4	5,4	0,228	–	12 000	0,11	62302-2RS1	–
17	26	5	1,68	0,93	0,039	56 000	28 000	0,0082	61803-2Z	–
	26	5	1,68	0,93	0,039	56 000	28 000	0,0082	61803-2RZ	–
	26	5	1,68	0,93	0,039	–	16 000	0,0082	61803-2RS1	–
	30	7	4,62	2,55	0,108	50 000	26 000	0,018	61903-2Z	–
	30	7	4,62	2,55	0,108	50 000	26 000	0,018	61903-2RZ	–
	30	7	4,62	2,55	0,108	–	14 000	0,018	61903-2RS1	–
	35	8	6,37	3,25	0,137	45 000	22 000	0,032	* 16003-2Z	–
	35	10	6,37	3,25	0,137	45 000	22 000	0,039	* 6003-2Z	* 6003-Z
	35	10	6,37	3,25	0,137	45 000	22 000	0,039	* 6003-2RSL	* 6003-RSL
	35	10	6,37	3,25	0,137	–	13 000	0,039	* 6003-2RSH	* 6003-RSH
	35	14	6,05	3,25	0,137	–	13 000	0,052	63003-2RS1	–
	40	12	9,95	4,75	0,2	38 000	19 000	0,065	* 6203-2Z	* 6203-Z
	40	12	9,95	4,75	0,2	38 000	19 000	0,065	* 6203-2RSL	* 6203-RSL
	40	12	9,95	4,75	0,2	–	12 000	0,065	* 6203-2RSH	* 6203-RSH
	40	16	9,56	4,75	0,2	–	12 000	0,083	62203-2RS1	–
	47	14	14,3	6,55	0,275	34 000	17 000	0,12	* 6303-2Z	* 6303-Z
	47	14	14,3	6,55	0,275	34 000	17 000	0,12	* 6303-2RSL	* 6303-RSL
	47	14	14,3	6,55	0,275	–	11 000	0,12	* 6303-2RSH	* 6303-RSH
47	19	13,5	6,55	0,275	–	11 000	0,15	62303-2RS1	–	

* SKF Explorer bearing

¹⁾ For bearings with only one shield or low-friction seal (Z, RZ, RSL), the limiting speeds for open bearings are valid

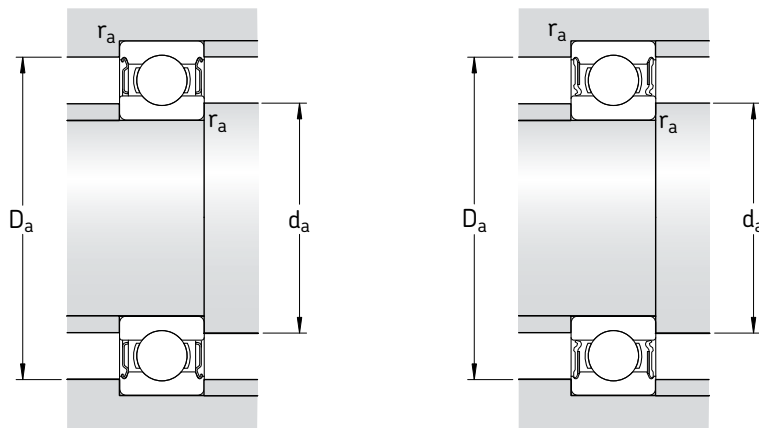

Dimensions					Abutment and fillet dimensions				Calculation factors	
d	d ₁	d ₂	D ₂	r _{1,2} min	d _a min	d _a max	D _a max	r _a max	k _r	f ₀
mm					mm				-	
15	17,9	-	22,1	0,3	17	-	22	0,3	0,015	10
	17,9	-	22,1	0,3	17	-	22	0,3	0,015	10
	18,4	-	25,8	0,3	17	-	26	0,3	0,02	14
	18,4	-	25,8	0,3	17	-	26	0,3	0,02	14
	-	17,4	25,8	0,3	17	17,3	26	0,3	0,02	14
	20,2	-	28,2	0,3	17	-	30	0,3	0,02	14
	20,5	-	28,2	0,3	17	-	30	0,3	0,025	14
	-	18,7	28,2	0,3	17	18,5	30	0,3	0,025	14
	-	18,7	28,2	0,3	17	18,5	30	0,3	0,025	14
	20,5	-	28,2	0,3	17	-	30	0,3	0,025	14
	21,7	-	30,4	0,6	19,2	-	30,8	0,6	0,025	13
	-	19,4	30,4	0,6	19,2	19,4	30,8	0,6	0,025	13
	-	19,4	30,4	0,6	19,2	19,4	30,8	0,6	0,025	13
	21,7	-	30,4	0,6	19,2	-	30,8	0,6	0,025	13
	23,7	-	36,3	1	20,6	-	36,4	1	0,03	12
	-	21,1	36,3	1	20,6	21	36,4	1	0,03	12
-	21,1	36,3	1	20,6	21	36,4	1	0,03	12	
23,7	-	36,3	1	20,6	-	36,4	1	0,03	12	
17	20,2	-	24,1	0,3	19	-	24	0,3	0,015	10
	20,2	-	24,1	0,3	19	-	24	0,3	0,015	10
	-	19,3	24,1	0,3	19	19,2	24	0,3	0,015	10
	20,4	-	27,8	0,3	19	-	28	0,3	0,02	15
	20,4	-	27,8	0,3	19	-	28	0,3	0,02	15
	-	19,4	27,8	0,3	19	19,3	28	0,3	0,02	15
	22,7	-	31,2	0,3	19	-	33	0,3	0,02	14
	23	-	31,4	0,3	19	-	33	0,3	0,025	14
	-	20,7	31,4	0,3	19	20,5	33	0,3	0,025	14
	-	20,7	31,4	0,3	19	20,5	33	0,3	0,025	14
	23	-	31,4	0,3	19	-	33	0,3	0,025	14
	24,5	-	35	0,6	21,2	-	35,8	0,6	0,025	13
	-	22,2	35	0,6	21,2	22	35,8	0,6	0,025	13
	-	22,2	35	0,6	21,2	22	35,8	0,6	0,025	13
	24,5	-	35	0,6	21,2	-	35,8	0,6	0,025	13
	26,5	-	39,7	1	22,6	-	41,4	1	0,03	12
	-	24	39,7	1	22,6	23,5	41,4	1	0,03	12
	-	24	39,7	1	22,6	23,5	41,4	1	0,03	12
	26,5	-	39,7	1	22,6	-	41,4	1	0,03	12

Sealed single row deep groove ball bearings

d 20 – 25 mm

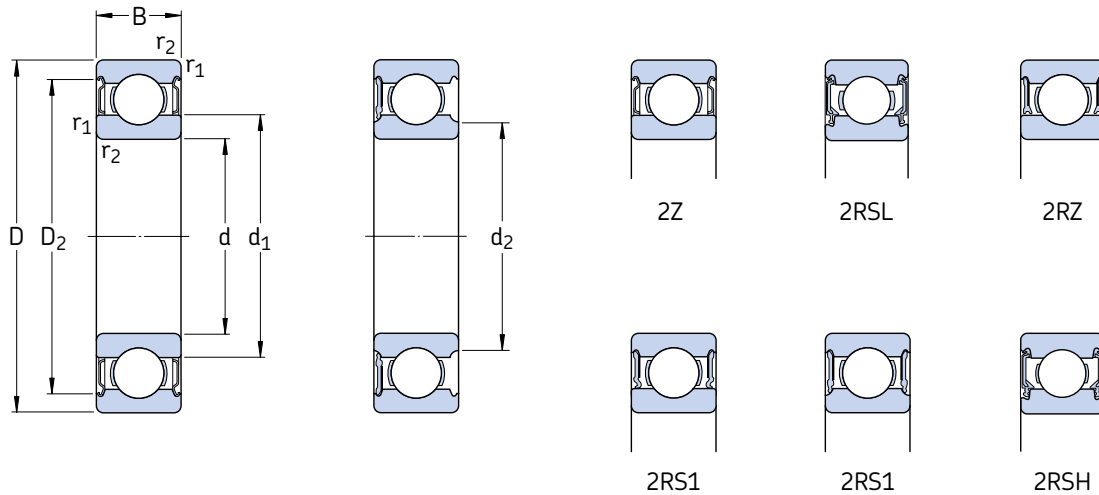

Principal dimensions			Basic load ratings		Fatigue load limit P_u	Speed ratings		Mass	Designations	
d	D	B	C	C_0		Reference speed	Limiting speed ¹⁾		Bearing sealed on both sides	one side
mm			kN		kN	r/min		kg	–	
20	32	7	4,03	2,32	0,104	45 000	22 000	0,018	61804-2RZ	–
	32	7	4,03	2,32	0,104	–	13 000	0,018	61804-2RS1	–
	37	9	6,37	3,65	0,156	43 000	20 000	0,038	61904-2RZ	–
	37	9	6,37	3,65	0,156	–	12 000	0,038	61904-2RS1	–
	42	12	9,95	5	0,212	38 000	19 000	0,069	* 6004-2Z	* 6004-Z
	42	12	9,95	5	0,212	38 000	19 000	0,069	* 6004-2RSL	* 6004-RSL
	42	12	9,95	5	0,212	–	11 000	0,069	* 6004-2RSH	* 6004-RSH
	42	16	9,36	5	0,212	–	11 000	0,086	63004-2RS1	–
	47	14	13,5	6,55	0,28	32 000	17 000	0,11	* 6204-2Z	* 6204-Z
	47	14	13,5	6,55	0,28	32 000	17 000	0,11	* 6204-2RSL	* 6204-RSL
	47	14	13,5	6,55	0,28	–	10 000	0,11	* 6204-2RSH	* 6204-RSH
	47	18	12,7	6,55	0,28	–	10 000	0,13	62204-2RS1	–
	52	15	16,8	7,8	0,335	30 000	15 000	0,14	* 6304-2Z	* 6304-Z
	52	15	16,8	7,8	0,335	30 000	15 000	0,14	* 6304-2RSL	* 6304-RSL
52	15	16,8	7,8	0,335	–	9 500	0,14	* 6304-2RSH	* 6304-RSH	
52	21	15,9	7,8	0,335	–	9 500	0,20	62304-2RS1	–	
22	50	14	14	7,65	0,325	–	9 000	0,12	62/22-2RS1	–
25	37	7	4,36	2,6	0,125	38 000	19 000	0,022	61805-2RZ	–
	37	7	4,36	2,6	0,125	–	11 000	0,022	61805-2RS1	–
	42	9	7,02	4,3	0,193	36 000	18 000	0,045	61905-2RZ	–
	42	9	7,02	4,3	0,193	–	10 000	0,045	61905-2RS1	–
	47	12	11,9	6,55	0,275	32 000	16 000	0,08	* 6005-2Z	* 6005-Z
	47	12	11,9	6,55	0,275	32 000	16 000	0,08	* 6005-2RSL	* 6005-RSL
	47	12	11,9	6,55	0,275	–	9 500	0,08	* 6005-2RSH	* 6005-RSH
	47	16	11,2	6,55	0,275	–	9 500	0,10	63005-2RS1	–
	52	15	14,8	7,8	0,335	28 000	14 000	0,13	* 6205-2Z	* 6205-Z
	52	15	14,8	7,8	0,335	28 000	14 000	0,13	* 6205-2RSL	* 6205-RSL
	52	15	14,8	7,8	0,335	–	8 500	0,13	* 6205-2RSH	* 6205-RSH
	52	18	14	7,8	0,335	–	8 500	0,15	62205-2RS1	–
	62	17	23,4	11,6	0,49	24 000	13 000	0,23	* 6305-2Z	* 6305-Z
	62	17	23,4	11,6	0,49	24 000	13 000	0,23	* 6305-2RZ	* 6305-RZ
62	17	23,4	11,6	0,49	–	7 500	0,23	* 6305-2RS1	* 6305-RS1	
62	24	22,5	11,6	0,49	–	7 500	0,32	62305-2RS1	–	

* SKF Explorer bearing

¹⁾ For bearings with only one shield or low-friction seal (Z, RZ, RSL), the limiting speeds for open bearings are valid

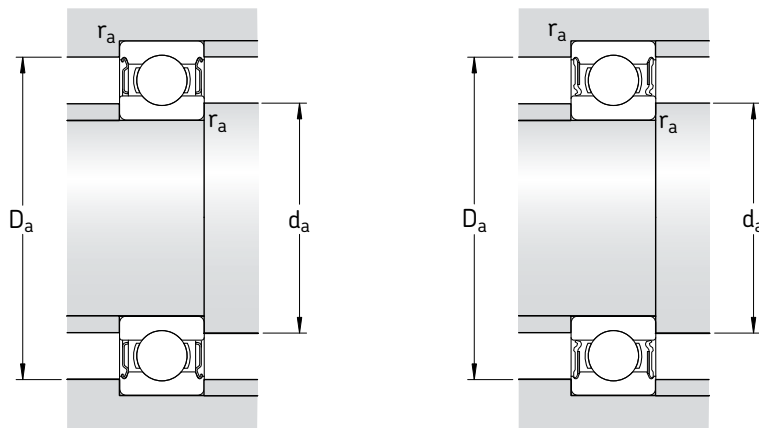

Dimensions					Abutment and fillet dimensions				Calculation factors	
d	d ₁ ~	d ₂ ~	D ₂ ~	r _{1,2} min	d _a min	d _a max	D _a max	r _a max	k _r	f ₀
mm					mm				-	
20	24	-	29,5	0,3	22	-	30	0,3	0,015	15
	-	22,6	29,5	0,3	22	22,5	30	0,3	0,015	15
	25,6	-	32,8	0,3	22	-	35	0,3	0,02	15
	-	24,2	32,8	0,3	22	24	35	0,3	0,02	15
	27,2	-	37,2	0,6	23,2	-	38,8	0,6	0,025	14
	-	24,9	37,2	0,6	23,2	24,5	38,8	0,6	0,025	14
	-	24,9	37,2	0,6	23,2	24,5	38,8	0,6	0,025	14
	27,2	-	37,2	0,6	23,2	-	38,8	0,6	0,025	14
	28,8	-	40,6	1	25,6	-	41,4	1	0,025	13
	-	26,3	40,6	1	25,6	26	41,4	1	0,025	13
	-	26,3	40,6	1	25,6	26	41,4	1	0,025	13
	28,8	-	40,6	1	25,6	-	41,4	1	0,025	13
	30,4	-	44,8	1,1	27	-	45	1	0,03	12
	-	27,2	44,8	1,1	27	27	45	1	0,03	12
	-	27,2	44,8	1,1	27	27	45	1	0,03	12
	30,4	-	44,8	1,1	27	-	45	1	0,03	12
22	32,2	-	44	1	27,6	32	44,4	1	0,025	14
25	28,5	-	34,3	0,3	27	-	35	0,3	0,015	14
	-	27,4	34,3	0,3	27	27,3	35	0,3	0,015	14
	30,2	-	37,8	0,3	27	-	40	0,3	0,02	15
	-	29,2	37,8	0,3	27	29	40	0,3	0,02	15
	32	-	42,2	0,6	28,2	-	43,8	0,6	0,025	14
	-	29,7	42,2	0,6	28,2	29,5	43,8	0,6	0,025	14
	-	29,7	42,2	0,6	28,2	29,5	43,8	0,6	0,025	14
	32	-	42,2	0,6	29,2	-	43,8	0,6	0,025	14
	34,4	-	46,3	1	30,6	-	46,4	1	0,025	14
	-	31,8	46,3	1	30,6	31,5	46,4	1	0,025	14
	-	31,8	46,3	1	30,6	31,5	46,4	1	0,025	14
	34,4	-	46,3	1	30,6	-	46,4	1	0,025	14
	36,6	-	52,7	1,1	32	-	55	1	0,03	12
	36,6	-	52,7	1,1	32	-	55	1	0,03	12
	36,6	-	52,7	1,1	32	-	55	1	0,03	12
	36,6	-	52,7	1,1	32	-	55	1	0,03	12

Sealed single row deep groove ball bearings

d 30 – 35 mm

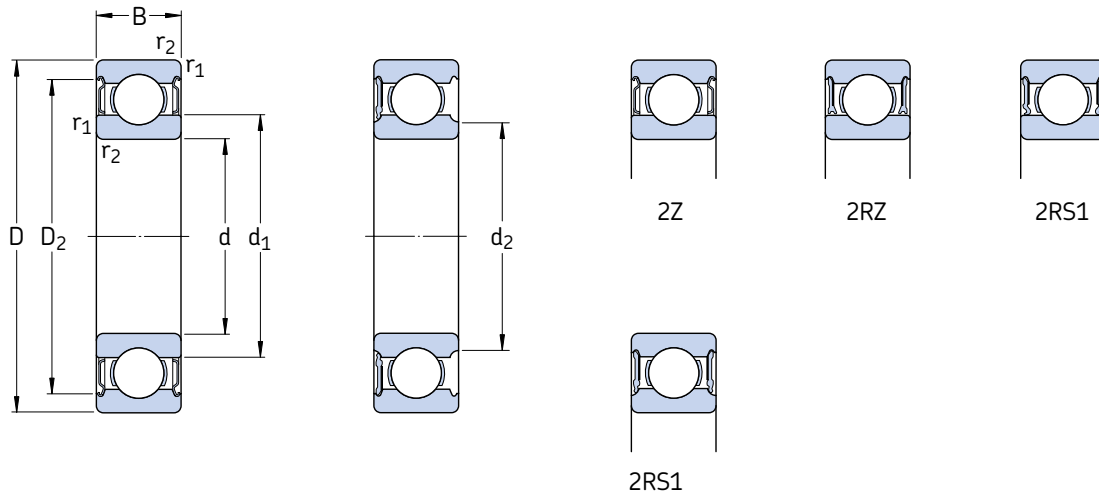

Principal dimensions			Basic load ratings		Fatigue load limit P_u	Speed ratings		Mass	Designations	
d	D	B	C	C_0		Reference speed	Limiting speed ¹⁾		Bearing sealed on both sides	one side
mm			kN		kN	r/min		kg	–	
30	42	7	4,49	2,9	0,146	32 000	16 000	0,027	61806-2RZ	–
	42	7	4,49	2,9	0,146	–	9 500	0,027	61806-2RS1	–
	47	9	7,28	4,55	0,212	30 000	15 000	0,051	61906-2RZ	–
	47	9	7,28	4,55	0,212	–	8 500	0,051	61906-2RS1	–
	55	13	13,8	8,3	0,355	28 000	14 000	0,12	* 6006-2Z	* 6006-Z
	55	13	13,8	8,3	0,355	28 000	14 000	0,12	* 6006-2RZ	* 6006-RZ
	55	13	13,8	8,3	0,355	–	8 000	0,12	* 6006-2RS1	* 6006-RS1
	55	19	13,3	8,3	0,355	–	8 000	0,16	63006-2RS1	–
	62	16	20,3	11,2	0,475	24 000	12 000	0,20	* 6206-2Z	* 6206-Z
	62	16	20,3	11,2	0,475	24 000	12 000	0,20	* 6206-2RZ	* 6206-RZ
	62	16	20,3	11,2	0,475	–	7 500	0,20	* 6206-2RS1	* 6206-RS1
	62	20	19,5	11,2	0,475	–	7 500	0,24	62206-2RS1	–
	72	19	29,6	16	0,67	20 000	11 000	0,35	* 6306-2Z	* 6306-Z
	72	19	29,6	16	0,67	20 000	11 000	0,35	* 6306-2RZ	* 6306-RZ
72	19	29,6	16	0,67	–	6 300	0,35	* 6306-2RS1	* 6306-RS1	
72	27	28,1	16	0,67	–	6 300	0,48	62306-2RS1	–	
35	47	7	4,75	3,2	0,166	28 000	14 000	0,03	61807-2RZ	–
	47	7	4,75	3,2	0,166	–	8 000	0,03	61807-2RS1	–
	55	10	9,56	6,8	0,29	26 000	13 000	0,08	61907-2RZ	–
	55	10	9,56	6,8	0,29	–	7 500	0,08	61907-2RS1	–
	62	14	16,8	10,2	0,44	24 000	12 000	0,16	* 6007-2Z	* 6007-Z
	62	14	16,8	10,2	0,44	24 000	12 000	0,16	* 6007-2RZ	* 6007-RZ
	62	14	16,8	10,2	0,44	–	7 000	0,16	* 6007-2RS1	* 6007-RS1
	62	20	15,9	10,2	0,44	–	7 000	0,21	63007-2RS1	–
	72	17	27	15,3	0,655	20 000	10 000	0,29	* 6207-2Z	* 6207-Z
	72	17	27	15,3	0,655	–	6 300	0,29	* 6207-2RS1	* 6207-RS1
	72	23	25,5	15,3	0,655	–	6 300	0,37	62207-2RS1	–
	80	21	35,1	19	0,815	19 000	9 500	0,46	* 6307-2Z	* 6307-Z
	80	21	35,1	19	0,815	–	6 000	0,46	* 6307-2RS1	* 6307-RS1
	80	31	33,2	19	0,815	–	6 000	0,66	62307-2RS1	–

* SKF Explorer bearing

¹⁾ For bearings with only one shield or low-friction seal (Z, RZ), the limiting speeds for open bearings are valid

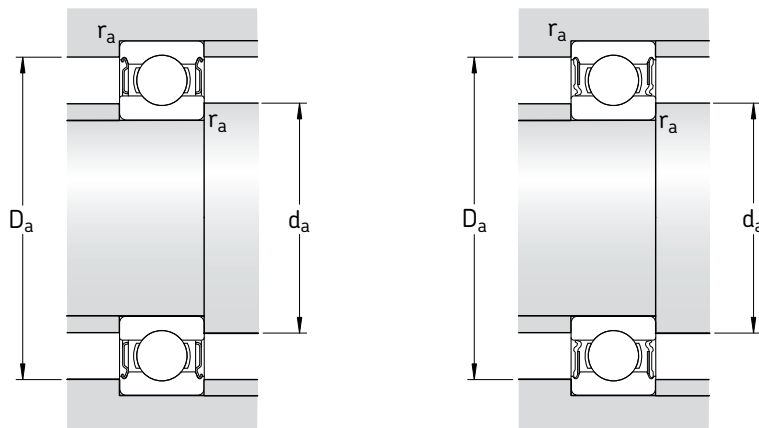

Dimensions					Abutment and fillet dimensions				Calculation factors	
d	d ₁ ~	d ₂ ~	D ₂ ~	r _{1,2} min	d _a min	d _a max	D _a max	r _a max	k _r	f ₀
mm					mm				-	
30	33,7	-	39,5	0,3	32	-	40	0,3	0,015	14
	-	32,6	39,5	0,3	32	32,5	40	0,3	0,015	14
	35,2	-	42,8	0,3	32	-	45	0,3	0,02	14
	-	34,2	42,8	0,3	32	34	45	0,3	0,02	14
	38,2	-	49	1	34,6	-	50,4	1	0,025	15
	38,2	-	49	1	34,6	-	50,4	1	0,025	15
	38,2	-	49	1	34,6	-	50,4	1	0,025	15
	38,2	-	49	1	34,6	-	50,4	1	0,025	15
	40,4	-	54,1	1	35,6	-	56,4	1	0,025	14
	40,4	-	54,1	1	35,6	-	56,4	1	0,025	14
	40,4	-	54,1	1	35,6	-	56,4	1	0,025	14
	40,4	-	54,1	1	35,6	-	56,4	1	0,025	14
	44,6	-	61,9	1,1	37	-	65	1	0,03	13
	44,6	-	61,9	1,1	37	-	65	1	0,03	13
	44,6	-	61,9	1,1	37	-	65	1	0,03	13
	44,6	-	61,9	1,1	37	-	65	1	0,03	13
35	38,7	-	44,4	0,3	37	-	45	0,3	0,015	14
	-	37,6	44,4	0,3	37	37,5	45	0,3	0,015	14
	41,6	-	50,5	0,6	38,2	-	51,8	0,6	0,02	14
	41,6	-	50,5	0,6	38,2	-	51,8	0,6	0,02	14
	43,8	-	55,6	1	39,6	-	57,4	1	0,025	15
	43,8	-	55,6	1	39,6	-	57,4	1	0,025	15
	43,8	-	55,6	1	39,6	-	57,4	1	0,025	15
	43,8	-	55,6	1	39,6	-	57,4	1	0,025	15
	46,9	-	62,7	1,1	42	-	65	1	0,025	14
	46,9	-	62,7	1,1	42	-	65	1	0,025	14
	46,9	-	62,7	1,1	42	-	65	1	0,025	14
	49,6	-	69,2	1,5	44	-	71	1,5	0,03	13
	49,6	-	69,2	1,5	44	-	71	1,5	0,03	13
	49,6	-	69,2	1,5	44	-	71	1,5	0,03	13

Sealed single row deep groove ball bearings
d 40 – 45 mm

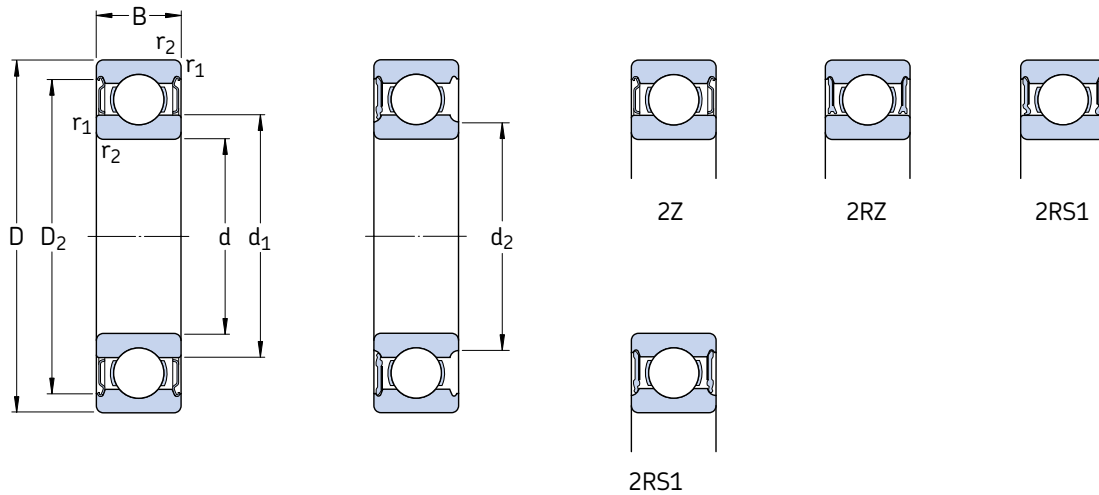

Principal dimensions			Basic load ratings		Fatigue load limit P_u	Speed ratings		Mass	Designations	
d	D	B	C	C_0		Reference speed	Limiting speed ¹⁾		Bearing sealed on both sides	one side
mm			kN		kN	r/min		kg	–	
40	52	7	4,94	3,45	0,186	26 000	13 000	0,034	61808-2RZ	–
	52	7	4,94	3,45	0,186	–	7 500	0,034	61808-2RS1	–
	62	12	13,8	10	0,425	24 000	12 000	0,12	61908-2RZ	–
	62	12	13,8	10	0,425	–	6 700	0,12	61908-2RS1	–
	68	15	17,8	11,6	0,49	22 000	11 000	0,19	* 6008-2Z	* 6008-Z
	68	15	17,8	11,6	0,49	22 000	11 000	0,19	* 6008-2RZ	* 6008-RZ
	68	15	17,8	11,6	0,49	–	6 300	0,19	* 6008-2RS1	* 6008-RS1
	68	21	16,8	11,6	0,49	–	6 300	0,26	63008-2RS1	–
	80	18	32,5	19	0,8	18 000	9 000	0,37	* 6208-2Z	* 6208-Z
	80	18	32,5	19	0,8	18 000	9 000	0,37	* 6208-2RZ	* 6208-RZ
	80	18	32,5	19	0,8	–	5 600	0,37	* 6208-2RS1	* 6208-RS1
	80	23	30,7	19	0,8	–	5 600	0,44	62208-2RS1	–
45	90	23	42,3	24	1,02	17 000	8 500	0,63	* 6308-2Z	* 6308-Z
	90	23	42,3	24	1,02	17 000	8 500	0,63	* 6308-2RZ	* 6308-RZ
	90	23	42,3	24	1,02	–	5 000	0,63	* 6308-2RS1	* 6308-RS1
	90	33	41	24	1,02	–	5 000	0,89	62308-2RS1	–
	58	7	6,63	6,1	0,26	22 000	11 000	0,04	61809-2RZ	–
	58	7	6,63	6,1	0,26	–	6 700	0,04	61809-2RS1	–
	68	12	14	10,8	0,465	20 000	10 000	0,14	61909-2RZ	–
	68	12	14	10,8	0,465	–	6 000	0,14	61909-2RS1	–
	75	16	22,1	14,6	0,64	20 000	10 000	0,25	* 6009-2Z	* 6009-Z
	75	16	22,1	14,6	0,64	–	5 600	0,25	* 6009-2RS1	* 6009-RS1
	75	23	20,8	14,6	0,64	–	5 600	0,34	63009-2RS1	–
	85	19	35,1	21,6	0,915	17 000	8 500	0,41	* 6209-2Z	* 6209-Z
85	19	35,1	21,6	0,915	–	5 000	0,41	* 6209-2RS1	* 6209-RS1	
85	23	33,2	21,6	0,915	–	5 000	0,48	62209-2RS1	–	
100	25	55,3	31,5	1,34	15 000	7 500	0,83	* 6309-2Z	* 6309-Z	
100	25	55,3	31,5	1,34	–	4 500	0,83	* 6309-2RS1	* 6309-RS1	
100	36	52,7	31,5	1,34	–	4 500	1,15	62309-2RS1	–	

* SKF Explorer bearing

¹⁾ For bearings with only one shield or low-friction seal (Z, RZ), the limiting speeds for open bearings are valid

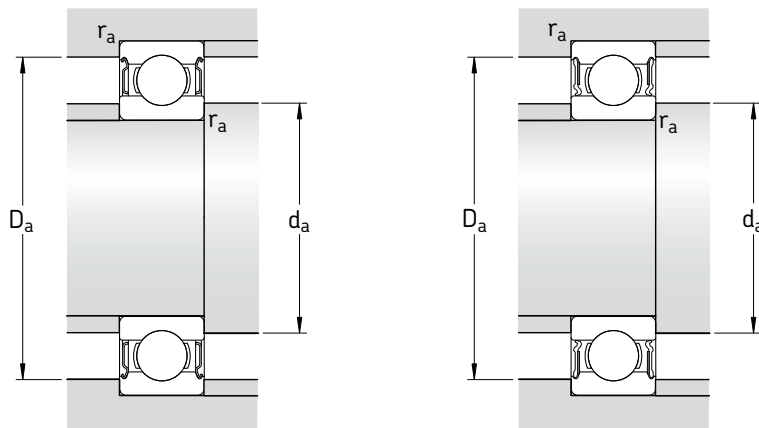

Dimensions					Abutment and fillet dimensions				Calculation factors	
d	d ₁ ~	d ₂ ~	D ₂ ~	r _{1,2} min	d _a min	d _a max	D _a max	r _a max	k _r	f ₀
mm					mm				-	
40	43,7	-	49,6	0,3	42	-	50	0,3	0,015	14
	-	42,6	49,6	0,3	42	42,5	50	0,3	0,015	14
	46,9	-	57,3	0,6	43,2	-	58,8	0,6	0,02	16
	46,9	-	57,3	0,6	43,2	-	58,8	0,6	0,02	16
	49,3	-	61,1	1	44,6	-	63,4	1	0,025	15
	49,3	-	61,1	1	44,6	-	63,4	1	0,025	15
	49,3	-	61,1	1	44,6	-	63,4	1	0,025	15
	49,3	-	61,1	1	44,6	-	63,4	1	0,025	15
	52,6	-	69,8	1,1	47	-	73	1	0,025	14
	52,6	-	69,8	1,1	47	-	73	1	0,025	14
	52,6	-	69,8	1,1	47	-	73	1	0,025	14
	52,6	-	69,8	1,1	47	-	73	1	0,025	14
	56,1	-	77,7	1,5	49	-	81	1,5	0,03	13
	56,1	-	77,7	1,5	49	-	81	1,5	0,03	13
	56,1	-	77,7	1,5	49	-	81	1,5	0,03	13
	56,1	-	77,7	1,5	49	-	81	1,5	0,03	13
45	49,1	-	55,4	0,3	47	-	56	0,3	0,015	17
	49,1	-	55,4	0,3	47	-	56	0,3	0,015	17
	52,4	-	62,8	0,6	48,2	-	64,8	0,6	0,02	16
	52,4	-	62,8	0,6	48,2	-	64,8	0,6	0,02	16
	54,8	-	67,8	1	50,8	-	69,2	1	0,025	15
	54,8	-	67,8	1	50,8	-	69,2	1	0,025	15
	54,8	-	67,8	1	50,8	-	69,2	1	0,025	15
	57,6	-	75,2	1,1	52	-	78	1	0,025	14
	57,6	-	75,2	1,1	52	-	78	1	0,025	14
	57,6	-	75,2	1,1	52	-	78	1	0,025	14
	62,2	-	86,7	1,5	54	-	91	1,5	0,03	13
	62,2	-	86,7	1,5	54	-	91	1,5	0,03	13
	62,2	-	86,7	1,5	54	-	91	1,5	0,03	13

Sealed single row deep groove ball bearings
d 50 – 55 mm

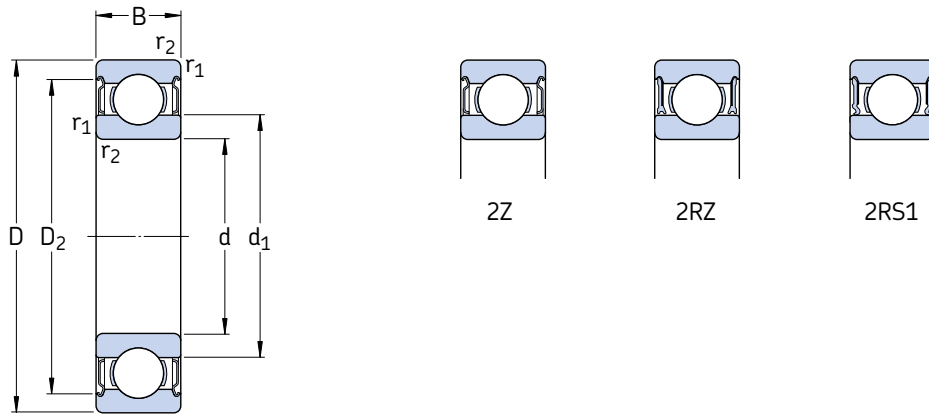

Principal dimensions			Basic load ratings		Fatigue load limit P_u	Speed ratings		Mass	Designations	
d	D	B	C	C_0		Reference speed	Limiting speed ¹⁾		Bearing sealed on both sides	one side
mm			kN		kN	r/min		kg	–	
50	65	7	6,76	6,8	0,285	20 000	10 000	0,052	61810-2RZ	–
	65	7	6,76	6,8	0,285	–	6 000	0,052	61810-2RS1	–
	72	12	14,6	11,8	0,5	19 000	9 500	0,14	61910-2RZ	–
	72	12	14,6	11,8	0,5	–	5 600	0,14	61910-2RS1	–
	80	16	22,9	16	0,71	18 000	9 000	0,26	* 6010-2Z	* 6010-Z
	80	16	22,9	16	0,71	18 000	9 000	0,26	* 6010-2RZ	* 6010-RZ
	80	16	22,9	16	0,71	–	5 000	0,26	* 6010-2RS1	* 6010-RS1
	80	23	21,6	16	0,71	–	5 000	0,37	63010-2RS1	–
	90	20	37,1	23,2	0,98	15 000	8 000	0,46	* 6210-2Z	* 6210-Z
	90	20	37,1	23,2	0,98	15 000	8 000	0,46	* 6210-2RZ	* 6210-RZ
	90	20	37,1	23,2	0,98	–	4 800	0,46	* 6210-2RS1	* 6210-RS1
	90	23	35,1	23,2	0,98	–	4 800	0,52	62210-2RS1	–
55	110	27	65	38	1,6	13 000	6 700	1,05	* 6310-2Z	* 6310-Z
	110	27	65	38	1,6	–	4 300	1,05	* 6310-2RS1	* 6310-RS1
	110	40	61,8	38	1,6	–	4 300	1,55	62310-2RS1	–
	72	9	9,04	8,8	0,375	19 000	9 500	0,083	61811-2RZ	–
	72	9	9,04	8,8	0,375	–	5 300	0,083	61811-2RS1	–
	80	13	16,5	14	0,6	17 000	8 500	0,19	61911-2RZ	–
	80	13	16,5	14	0,6	–	5 000	0,19	61911-2RS1	–
	90	18	29,6	21,2	0,9	16 000	8 000	0,39	* 6011-2Z	* 6011-Z
	90	18	29,6	21,2	0,9	–	4 500	0,39	* 6011-2RS1	* 6011-RS1
	100	21	46,2	29	1,25	14 000	7 000	0,61	* 6211-2Z	* 6211-Z
	100	21	46,2	29	1,25	–	4 300	0,61	* 6211-2RS1	* 6211-RS1
	100	25	43,6	29	1,25	–	4 300	0,70	62211-2RS1	–
	120	29	74,1	45	1,9	12 000	6 300	1,35	* 6311-2Z	* 6311-Z
	120	29	74,1	45	1,9	–	3 800	1,35	* 6311-2RS1	* 6311-RS1
	120	43	71,5	45	1,9	–	3 800	1,95	62311-2RS1	–

* SKF Explorer bearing

¹⁾ For bearings with only one shield or low-friction seal (Z, RZ), the limiting speeds for open bearings are valid

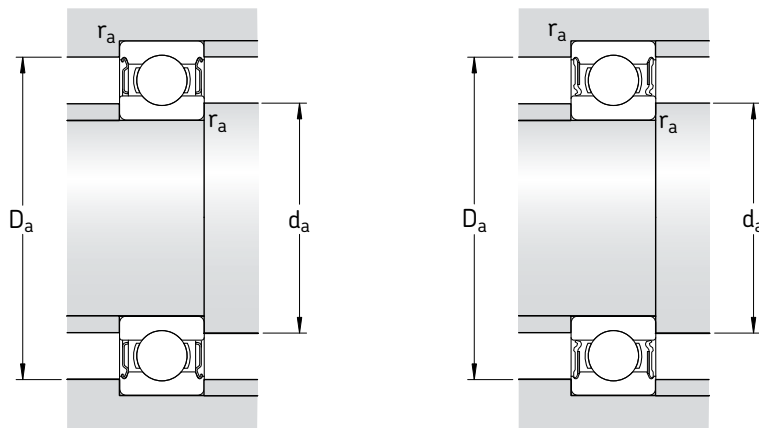

Dimensions				Abutment and fillet dimensions			Calculation factors	
d	d ₁ ~	D ₂ ~	r _{1,2} min	d _a min	D _a max	r _a max	k _r	f ₀
mm				mm			-	
50	55,1	61,8	0,3	52	63	0,3	0,015	17
	55,1	61,8	0,3	52	63	0,3	0,015	17
	56,9	67,3	0,6	53,2	68,8	0,6	0,02	16
	56,9	67,3	0,6	53,2	68,8	0,6	0,02	16
	59,8	72,8	1	54,6	75,4	1	0,025	15
	59,8	72,8	1	54,6	75,4	1	0,025	15
	59,8	72,8	1	54,6	75,4	1	0,025	15
	59,8	72,8	1	54,6	75,4	1	0,025	15
	62,5	81,6	1,1	57	83	1	0,025	14
	62,5	81,6	1,1	57	83	1	0,025	14
	62,5	81,6	1,1	57	83	1	0,025	14
	62,5	81,6	1,1	57	83	1	0,025	14
55	68,8	95,2	2	61	99	2	0,03	13
	68,8	95,2	2	61	99	2	0,03	13
	68,8	95,2	2	61	99	2	0,03	13
	60,6	68,6	0,3	57	70	0,3	0,015	17
	60,6	68,6	0,3	57	70	0,3	0,015	17
	63,2	74,2	1	59,6	75,4	1	0,02	16
	63,2	74,2	1	59,6	75,4	1	0,02	16
	66,3	81,5	1,1	61	84	1	0,025	15
	66,3	81,5	1,1	61	84	1	0,025	15
	69,1	89,4	1,5	64	91	1,5	0,025	14
	69,1	89,4	1,5	64	91	1,5	0,025	14
	69,1	89,4	1,5	64	91	1,5	0,025	14
75,3	104	2	66	109	2	0,03	13	
75,3	104	2	66	109	2	0,03	13	
75,3	104	2	66	109	2	0,03	13	

Sealed single row deep groove ball bearings d 60 – 65 mm

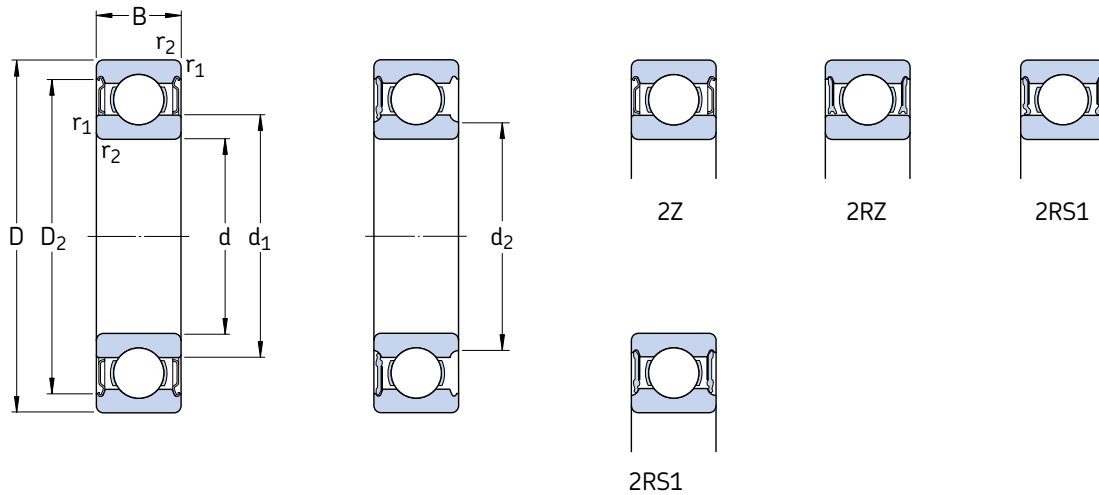

Principal dimensions			Basic load ratings dynamic static		Fatigue load limit P_u	Speed ratings Reference speed Limiting speed ¹⁾		Mass kg	Designations Bearing sealed on both sides one side	
d	D	B	C	C_0						
mm			kN		kN	r/min			–	
60	78	10	11,9	11,4	0,49	17 000	8 500	0,11	61812-2RZ	–
	78	10	11,9	11,4	0,49	–	4 800	0,11	61812-2RS1	–
	85	13	16,5	14,3	0,6	16 000	8 000	0,20	61912-2RZ	–
	85	13	16,5	14,3	0,6	–	4 500	0,20	61912-2RS1	–
	95	18	30,7	23,2	0,98	15 000	7 500	0,42	* 6012-2Z	* 6012-Z
	95	18	30,7	23,2	0,98	15 000	7 500	0,42	* 6012-2RZ	* 6012-RZ
	95	18	30,7	23,2	0,98	–	4 300	0,42	* 6012-2RS1	* 6012-RS1
	110	22	55,3	36	1,53	13 000	6 300	0,78	* 6212-2Z	* 6212-Z
	110	22	55,3	36	1,53	–	4 000	0,78	* 6212-2RS1	* 6212-RS1
	110	28	52,7	36	1,53	–	4 000	0,97	62212-2RS1	–
65	130	31	85,2	52	2,2	11 000	5 600	1,70	* 6312-2Z	* 6312-Z
	130	31	85,2	52	2,2	–	3 400	1,70	* 6312-2RS1	* 6312-RS1
	130	46	81,9	52	2,2	–	3 400	2,50	62312-2RS1	–
	85	10	12,4	12,7	0,54	16 000	8 000	0,13	61813-2RZ	–
	85	10	12,4	12,7	0,54	–	4 500	0,13	61813-2RS1	–
	90	13	17,4	16	0,68	15 000	7 500	0,22	61913-2RZ	–
	90	13	17,4	16	0,68	–	4 300	0,22	61913-2RS1	–
	100	18	31,9	25	1,06	14 000	7 000	0,44	* 6013-2Z	* 6013-Z
	100	18	31,9	25	1,06	–	4 000	0,44	* 6013-2RS1	* 6013-RS1
	120	23	58,5	40,5	1,73	12 000	6 000	0,99	* 6213-2Z	* 6213-Z
120	23	58,5	40,5	1,73	–	3 600	0,99	* 6213-2RS1	* 6213-RS1	
120	31	55,9	40,5	1,73	–	3 600	1,25	62213-2RS1	–	
140	33	97,5	60	2,5	10 000	5 300	2,10	* 6313-2Z	* 6313-Z	
140	33	97,5	60	2,5	–	3 200	2,10	* 6313-2RS1	* 6313-RS1	
140	48	92,3	60	2,5	–	3 200	3,00	62313-2RS1	–	

* SKF Explorer bearing

¹⁾ For bearings with only one shield or low-friction seal (Z, RZ), the limiting speeds for open bearings are valid

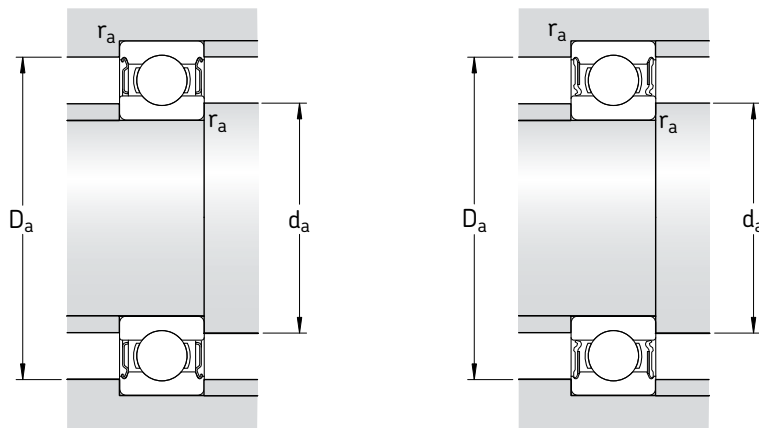

Dimensions					Abutment and fillet dimensions				Calculation factors	
d	d ₁ ~	d ₂ ~	D ₂ ~	r _{1,2} min	d _a min	d _a max	D _a max	r _a max	k _r	f ₀
mm					mm				-	
60	65,6	-	74,5	0,3	62	-	76	0,3	0,015	17
	65,6	-	74,5	0,3	62	-	76	0,3	0,015	17
	68,2	-	79,2	1	64,6	-	80,4	1	0,02	16
	68,2	-	79,2	1	64,6	-	80,4	1	0,02	16
	71,3	-	86,5	1,1	66	-	89	1	0,025	16
	71,3	-	86,5	1,1	66	-	89	1	0,025	16
	71,3	-	86,5	1,1	66	-	89	1	0,025	16
	75,5	-	98	1,5	69	-	101	1,5	0,025	14
	75,5	-	98	1,5	69	-	101	1,5	0,025	14
	75,5	-	98	1,5	69	-	101	1,5	0,025	14
	81,9	-	112	2,1	72	-	118	2	0,03	13
	81,9	-	112	2,1	72	-	118	2	0,03	13
81,9	-	112	2,1	72	-	118	2	0,03	13	
65	71,6	-	80,5	0,6	68,2	-	81,8	0,6	0,015	17
	71,6	-	80,5	0,6	68,2	-	81,8	0,6	0,015	17
	73,2	-	84,2	1	69,6	-	85,4	1	0,02	17
	-	73,2	84,2	1	69,6	73	85,4	1	0,02	17
	76,3	-	91,5	1,1	71	-	94	1	0,025	16
	76,3	-	91,5	1,1	71	-	94	1	0,025	16
	83,3	-	106	1,5	74	-	111	1,5	0,025	15
	83,3	-	106	1,5	74	-	111	1,5	0,025	15
	83,3	-	106	1,5	74	-	111	1,5	0,025	15
	88,4	-	121	2,1	77	-	128	2	0,03	13
	88,4	-	121	2,1	77	-	128	2	0,03	13
	88,4	-	121	2,1	77	-	128	2	0,03	13

Sealed single row deep groove ball bearings

d 70 – 80 mm

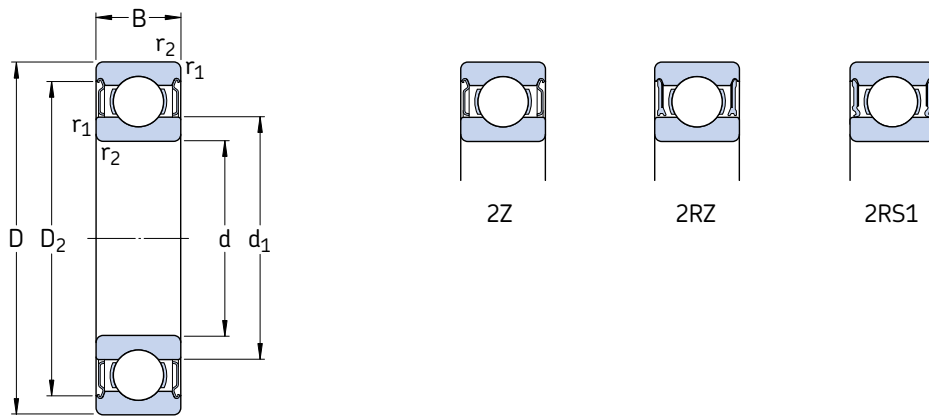

Principal dimensions			Basic load ratings		Fatigue load limit P_u	Speed ratings		Mass	Designations	
d	D	B	C	C_0		Reference speed	Limiting speed ¹⁾		Bearing sealed on both sides	one side
mm			kN		kN	r/min		kg	–	
70	90	10	12,4	13,2	0,56	15 000	7 500	0,14	61814-2RZ	–
	90	10	12,4	13,2	0,56	–	4 300	0,14	61814-2RS1	–
	100	16	23,8	21,2	0,9	14 000	7 000	0,35	61914-2RZ	–
	100	16	23,8	21,2	0,9	–	4 000	0,35	61914-2RS1	–
	110	20	39,7	31	1,32	13 000	6 300	0,60	* 6014-2Z	* 6014-Z
	110	20	39,7	31	1,32	–	3 600	0,60	* 6014-2RS1	* 6014-RS1
	125	24	63,7	45	1,9	11 000	5 600	1,10	* 6214-2Z	* 6214-Z
	125	24	63,7	45	1,9	–	3 400	1,10	* 6214-2RS1	* 6214-RS1
	125	31	60,5	45	1,9	–	3 400	1,30	62214-2RS1	–
	150	35	111	68	2,75	9 500	5 000	2,50	* 6314-2Z	* 6314-Z
	150	35	111	68	2,75	–	3 000	2,50	* 6314-2RS1	* 6314-RS1
	150	51	104	68	2,75	–	3 000	3,55	62314-2RS1	–
75	95	10	12,7	14,3	0,61	14 000	7 000	0,15	61815-2RZ	–
	95	10	12,7	14,3	0,61	–	4 000	0,15	61815-2RS1	–
	105	16	24,2	19,3	0,965	13 000	6 300	0,37	61915-2RZ	–
	105	16	24,2	19,3	0,965	–	3 600	0,37	61915-2RS1	–
	115	20	41,6	33,5	1,43	12 000	6 000	0,64	* 6015-2Z	* 6015-Z
	115	20	41,6	33,5	1,43	12 000	6 000	0,64	* 6015-2RZ	* 6015-RZ
	115	20	41,6	33,5	1,43	–	3 400	0,64	* 6015-2RS1	* 6015-RS1
	130	25	68,9	49	2,04	10 000	5 300	1,20	* 6215-2Z	* 6215-Z
	130	25	68,9	49	2,04	–	3 200	1,20	* 6215-2RS1	* 6215-RS1
	160	37	119	76,5	3	9 000	4 500	3,00	* 6315-2Z	* 6315-Z
	160	37	119	76,5	3	–	2 800	3,00	* 6315-2RS1	* 6315-RS1
	80	100	10	13	15	0,64	13 000	6 300	0,15	61816-2RZ
100		10	13	15	0,64	–	3 600	0,15	61816-2RS1	–
110		16	25,1	20,4	1,02	12 000	6 000	0,40	61916-2RZ	–
110		16	25,1	20,4	1,02	–	3 400	0,40	61916-2RS1	–
125		22	49,4	40	1,66	11 000	5 600	0,85	* 6016-2Z	* 6016-Z
125		22	49,4	40	1,66	–	3 200	0,85	* 6016-2RS1	* 6016-RS1
140		26	72,8	55	2,2	9 500	4 800	1,40	* 6216-2Z	* 6216-Z
140		26	72,8	55	2,2	–	3 000	1,40	* 6216-2RS1	* 6216-RS1
170		39	130	86,5	3,25	8 500	4 300	3,60	* 6316-2Z	* 6316-Z
170		39	130	86,5	3,25	–	2 600	3,60	* 6316-2RS1	* 6316-RS1

* SKF Explorer bearing

¹⁾ For bearings with only one shield or low-friction seal (Z, RZ), the limiting speeds for open bearings are valid

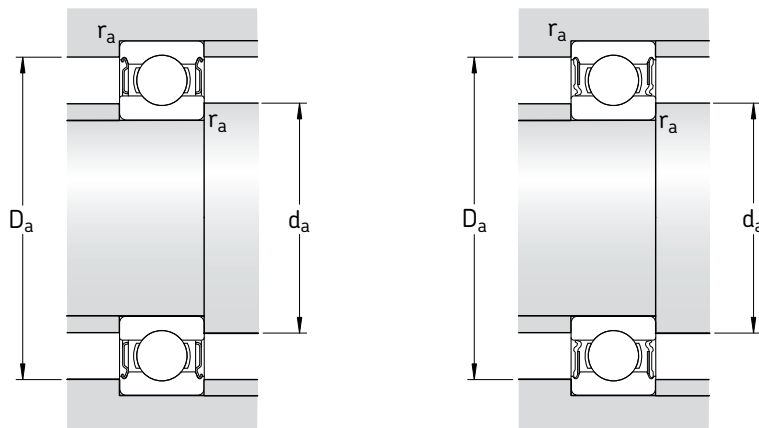

Dimensions				Abutment and fillet dimensions			Calculation factors	
d	d ₁ ~	D ₂ ~	r _{1,2} min	d _a min	D _a max	r _a max	k _r	f ₀
mm				mm			-	
70	76,6	85,5	0,6	73,2	86,8	0,6	0,015	17
	76,6	85,5	0,6	73,2	86,8	0,6	0,015	17
	79,7	93,3	1	74,6	95,4	1	0,02	16
	79,7	93,3	1	74,6	95,4	1	0,02	16
	82,9	99,9	1,1	76	104	1	0,025	16
	82,9	99,9	1,1	76	104	1	0,025	16
	87,1	111	1,5	79	116	1,5	0,025	15
	87,1	111	1,5	79	116	1,5	0,025	15
	87,1	111	1,5	79	116	1,5	0,025	15
	95	130	2,1	82	138	2	0,03	13
	95	130	2,1	82	138	2	0,03	13
	95	130	2,1	82	138	2	0,03	13
75	81,6	90,5	0,6	78,2	91,8	0,6	0,015	17
	81,6	90,5	0,6	78,2	91,8	0,6	0,015	17
	84,7	98,3	1	79,6	100	1	0,02	14
	84,7	98,3	1	79,6	100	1	0,02	14
	87,9	105	1,1	81	109	1	0,025	16
	87,9	105	1,1	81	109	1	0,025	16
	87,9	105	1,1	81	109	1	0,025	16
	92,1	117	1,5	84	121	1,5	0,025	15
	92,1	117	1,5	84	121	1,5	0,025	15
	101	138	2,1	87	148	2	0,03	13
	101	138	2,1	87	148	2	0,03	13
	80	86,6	95,5	0,6	83,2	96,8	0,6	0,015
86,6		95,5	0,6	83,2	96,8	0,6	0,015	17
89,8		102	1	84,6	105	1	0,02	14
89,8		102	1	84,6	105	1	0,02	14
94,4		114	1,1	86	119	1	0,025	16
94,4		114	1,1	86	119	1	0,025	16
101		127	2	91	129	2	0,025	15
101		127	2	91	129	2	0,025	15
108		147	2,1	92	158	2	0,03	13
108		147	2,1	92	158	2	0,03	13

Sealed single row deep groove ball bearings

d 85 – 100 mm

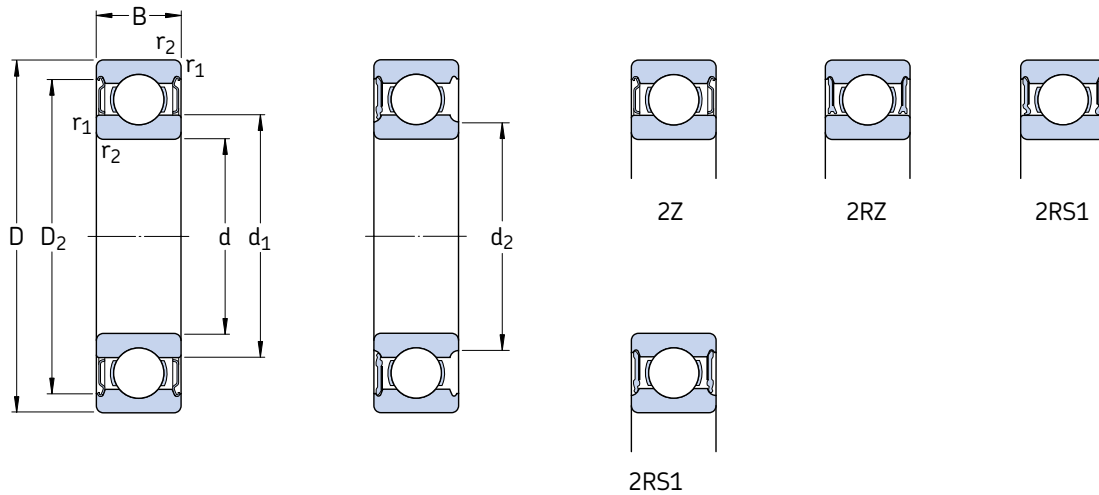

Principal dimensions			Basic load ratings dynamic static		Fatigue load limit	Speed ratings		Mass	Designations	
d	D	B	C	C ₀	P _u	Reference speed	Limiting speed ¹⁾	kg	Bearing sealed on both sides	one side
mm			kN		kN	r/min		kg	–	
85	110	13	19,5	20,8	0,88	12 000	6 000	0,27	61817-2RZ	–
	110	13	19,5	20,8	0,88	–	3 400	0,27	61817-2RS1	–
	130	22	52	43	1,76	11 000	5 300	0,89	* 6017-2Z	* 6017-Z
	130	22	52	43	1,76	–	3 000	0,89	* 6017-2RS1	* 6017-RS1
	150	28	87,1	64	2,5	9 000	4 500	1,80	* 6217-2Z	* 6217-Z
	150	28	87,1	64	2,5	–	2 800	1,80	* 6217-2RS1	* 6217-RS1
	180	41	140	96,5	3,55	8 000	4 000	4,25	* 6317-2Z	* 6317-Z
	180	41	140	96,5	3,55	–	2 400	4,25	* 6317-2RS1	* 6317-RS1
90	115	13	19,5	22	0,915	11 000	5 600	0,28	61818-2RZ	–
	115	13	19,5	22	0,915	–	3 200	0,28	61818-2RS1	–
	140	24	60,5	50	1,96	10 000	5 000	1,15	* 6018-2Z	* 6018-Z
	140	24	60,5	50	1,96	–	2 800	1,15	* 6018-2RS1	* 6018-RS1
	160	30	101	73,5	2,8	8 500	4 300	2,15	* 6218-2Z	* 6218-Z
	160	30	101	73,5	2,8	–	2 600	2,15	* 6218-2RS1	* 6218-RS1
	190	43	151	108	3,8	7 500	3 800	4,90	* 6318-2Z	* 6318-Z
	190	43	151	108	3,8	–	2 400	4,90	* 6318-2RS1	* 6318-RS1
95	120	13	19,9	22,8	0,93	11 000	5 300	0,30	61819-2RZ	–
	120	13	19,9	22,8	0,93	–	3 000	0,30	61819-2RS1	–
	130	18	33,8	33,5	1,43	–	3 000	0,61	61919-2RS1	–
	145	24	63,7	54	2,08	9 500	4 800	1,20	* 6019-2Z	* 6019-Z
	145	24	63,7	54	2,08	–	2 800	1,20	* 6019-2RS1	* 6019-RS1
	170	32	114	81,5	3	8 000	4 000	2,60	* 6219-2Z	* 6219-Z
	170	32	114	81,5	3	–	2 400	2,60	* 6219-2RS1	* 6219-RS1
	200	45	159	118	4,15	7 000	3 600	5,65	* 6319-2Z	* 6319-Z
	200	45	159	118	4,15	–	2 200	5,65	* 6319-2RS1	* 6319-RS1
	100	125	13	19,9	24	0,95	10 000	5 300	0,31	61820-2RZ
125		13	19,9	24	0,95	–	3 000	0,31	61820-2RS1	–
150		24	63,7	54	2,04	9 500	4 500	1,25	* 6020-2Z	* 6020-Z
150		24	63,7	54	2,04	–	2 600	1,25	* 6020-2RS1	* 6020-RS1
180		34	127	93	3,35	7 500	3 800	3,15	* 6220-2Z	* 6220-Z
180		34	127	93	3,35	–	2 400	3,15	* 6220-2RS1	* 6220-RS1
215		47	174	140	4,75	6 700	3 400	7,00	6320-2Z	6320-Z

* SKF Explorer bearing

¹⁾ For bearings with only one shield or low-friction seal (Z, RZ), the limiting speeds for open bearings are valid

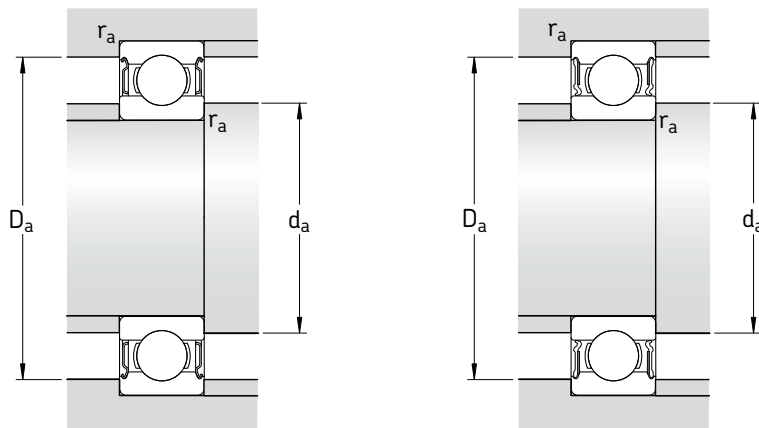

Dimensions					Abutment and fillet dimensions				Calculation factors		
d	d ₁	d ₂	D ₂	r _{1,2} min	d _a min	d _a max	D _a max	r _a max	k _r	f ₀	
mm					mm				-		
85	93,2	-	104	1	89,6	-	105	1	0,015	17	
	93,2	-	104	1	89,6	-	105	1	0,015	17	
	99,4	-	119	1,1	92	-	123	1	0,025	16	
	99,4	-	119	1,1	92	-	123	1	0,025	16	
	106	-	134	2	96	-	139	2	0,025	15	
	106	-	134	2	96	-	139	2	0,025	15	
	115	-	155	3	99	-	166	2,5	0,03	13	
	115	-	155	3	99	-	166	2,5	0,03	13	
90	98,2	-	109	1	94,6	-	110	1	0,015	17	
	98,2	-	109	1	94,6	-	110	1	0,015	17	
	106	-	128	1,5	97	-	133	1,5	0,025	16	
	106	-	128	1,5	97	-	133	1,5	0,025	16	
	113	-	143	2	101	-	149	2	0,025	15	
	-	106	143	2	101	105	149	2	0,025	15	
	121	-	164	3	104	-	176	2,5	0,03	13	
	121	-	164	3	104	-	176	2,5	0,03	13	
95	103	-	114	1	99,6	-	115	1	0,015	17	
	103	-	114	1	99,6	-	115	1	0,015	17	
	106	-	122	1,1	101	-	124	1	0,02	17	
	111	-	133	1,5	102	-	138	1,5	0,025	16	
	110	-	133	1,5	102	-	138	1,5	0,025	16	
	118	-	151	2,1	107	-	158	2	0,025	14	
	-	112	151	2,1	107	111	158	2	0,025	14	
	128	-	172	3	109	-	186	2,5	0,03	13	
	-	121	172	3	109	120	186	2,5	0,03	13	
	100	108	-	119	1	105	-	120	1	0,015	17
		108	-	119	1	105	-	120	1	0,015	17
		116	-	138	1,5	107	-	143	1,5	0,025	16
-		110	138	1,5	107	109	143	1,5	0,025	16	
125		-	160	2,1	112	-	168	2	0,025	14	
-		118	160	2,1	112	117	168	2	0,025	14	
136		-	184	3	114	-	201	2,5	0,03	13	

Sealed single row deep groove ball bearings d 105 – 160 mm

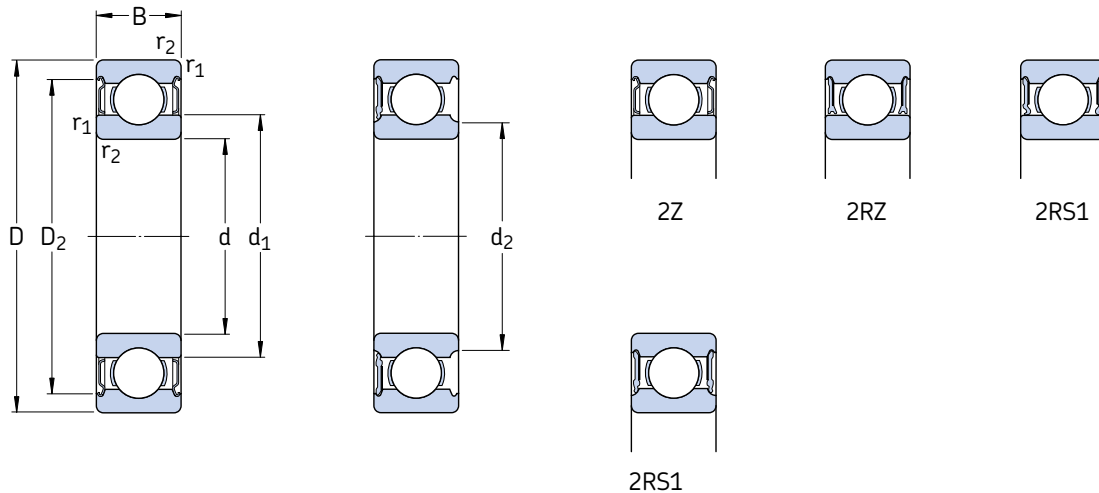

Principal dimensions			Basic load ratings		Fatigue load limit P_u	Speed ratings		Mass	Designations	
d	D	B	C	C_0		Reference speed	Limiting speed ¹⁾		Bearing sealed on both sides	one side
mm			kN		kN	r/min		kg	–	
105	130	13	20,8	19,6	1	10 000	5 000	0,32	61821-2RZ	–
	130	13	20,8	19,6	1	–	2 800	0,32	61821-2RS1	–
	160	26	76,1	65,5	2,4	8 500	4 300	1,60	* 6021-2Z	* 6021-Z
	160	26	76,1	65,5	2,4	–	2 400	1,60	* 6021-2RS1	* 6021-RS1
	190	36	140	104	3,65	7 000	3 600	3,70	* 6221-2Z	* 6221-Z
190	36	140	104	3,65	–	2 200	3,70	* 6221-2RS1	* 6221-RS1	
225	49	182	153	5,1	6 300	3 200	8,25	6321-2Z	6321-Z	
110	140	16	28,1	26	1,25	9 500	4 500	0,60	61822-2RZ	–
	140	16	28,1	26	1,25	–	2 600	0,60	61822-2RS1	–
	170	28	85,2	73,5	2,4	8 000	4 000	1,95	* 6022-2Z	* 6022-Z
	170	28	85,2	73,5	2,4	–	2 400	1,95	* 6022-2RS1	* 6022-RS1
	200	38	151	118	4	6 700	3 400	4,35	* 6222-2Z	* 6222-Z
120	150	16	29,1	28	1,29	8 500	4 300	0,65	61824-2RZ	–
	150	16	29,1	28	1,29	–	2 400	0,65	61824-2RS1	–
	180	28	88,4	80	2,75	7 500	3 800	2,05	* 6024-2Z	* 6024-Z
	180	28	88,4	80	2,75	–	2 200	2,05	* 6024-2RS1	* 6024-RS1
	215	40	146	118	3,9	6 300	3 200	5,15	6224-2Z	6224-Z
130	165	18	37,7	43	1,6	8 000	3 800	0,93	61826-2RZ	–
	165	18	37,7	43	1,6	–	2 200	0,93	61826-2RS1	–
	200	33	112	100	3,35	7 000	3 400	3,15	* 6026-2Z	* 6026-Z
	200	33	112	100	3,35	–	2 000	3,15	* 6026-2RS1	* 6026-RS1
	230	40	156	132	4,15	5 600	3 000	5,80	6226-2Z	6226-Z
140	175	18	39	46,5	1,66	7 500	3 600	0,99	61828-2RZ	–
	175	18	39	46,5	1,66	–	2 000	0,99	61828-2RS1	–
	210	33	111	108	3,45	6 700	3 200	3,35	6028-2Z	6028-Z
	210	33	111	108	3,45	–	1 800	3,35	6028-2RS1	6028-RS1
150	225	35	125	125	3,9	6 000	3 000	4,80	6030-2Z	6030-Z
	225	35	125	125	3,9	–	1 700	4,80	6030-2RS1	6030-RS1
160	240	38	143	143	4,3	5 600	2 800	5,90	6032-2Z	6032-Z
	240	38	143	143	4,3	–	1 600	5,90	6032-2RS1	6032-RS1

* SKF Explorer bearing

¹⁾ For bearings with only one shield or low-friction seal (Z, RZ), the limiting speeds for open bearings are valid

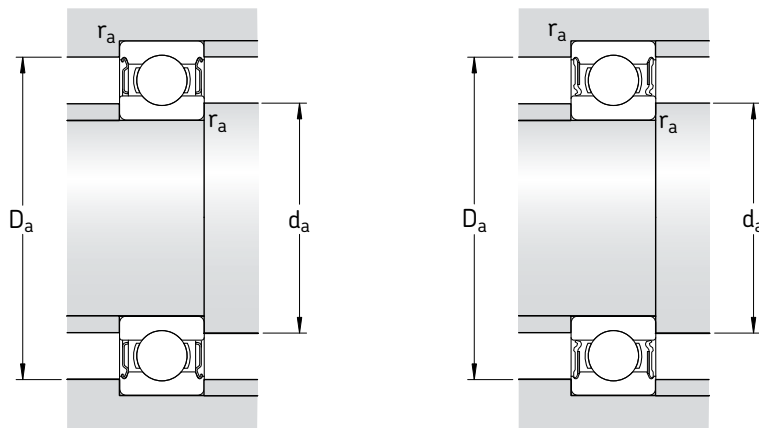

Dimensions					Abutment and fillet dimensions				Calculation factors	
d	d ₁ ~	d ₂ ~	D ₂ ~	r _{1,2} min	d _a min	d _a max	D _a max	r _a max	k _r	f ₀
mm					mm				-	
105	112	-	124	1	110	-	125	1	0,015	13
	-	111	124	1	110	110	125	1	0,015	13
	123	-	147	2	116	-	149	2	0,025	16
	-	117	147	2	116	116	149	2	0,025	16
	131	-	167	2,1	117	-	178	2	0,025	14
	-	125	167	2,1	117	124	178	2	0,025	14
	141	-	193	3	119	-	211	2,5	0,03	13
110	119	-	134	1	115	-	135	1	0,015	14
	-	115	134	1	115	115	135	1	0,015	14
	129	-	155	2	119	-	161	2	0,025	16
	129	-	155	2	119	-	161	2	0,025	16
	138	-	177	2,1	122	-	188	2	0,025	14
120	129	-	144	1	125	-	145	1	0,015	13
	-	125	144	1	125	125	145	1	0,015	13
	139	-	165	2	129	-	171	2	0,025	16
	-	133	165	2	129	132	171	2	0,025	16
	151	-	189	2,1	132	-	203	2	0,025	14
130	140	-	158	1,1	136	-	159	1	0,015	16
	-	137	158	1,1	136	136	159	1	0,015	16
	153	-	182	2	139	-	191	2	0,025	16
	153	-	182	2	139	-	191	2	0,025	16
	161	-	203	3	144	-	216	2,5	0,025	15
140	151	-	167	1,1	146	-	169	1	0,015	16
	-	148	167	1,1	146	147	169	1	0,015	16
	163	-	192	2	149	-	201	2	0,025	16
	-	156	192	2	149	155	201	2	0,025	16
150	174	-	205	2,1	160	-	215	2	0,025	16
	174	-	205	2,1	160	-	215	2	0,025	16
160	186	-	219	2,1	169	-	231	2	0,025	16
	-	179	219	2,1	169	178	231	2	0,025	16

ICOS™ oil sealed bearing units
d 12 – 30 mm

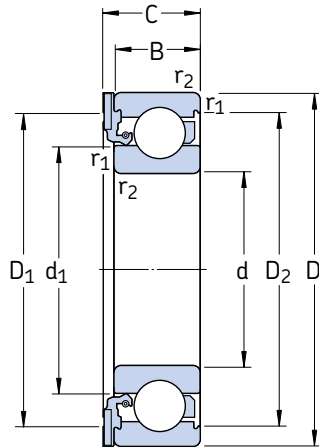

Principal dimensions				Basic load ratings		Fatigue load limit P_u	Limiting speed	Mass	Designation
d	D	B	C	dynamic	static				
mm				C	C_0	kN	r/min	kg	–
12	32	10	12,6	7,28	3,1	0,132	14 000	0,041	* ICOS-D1B01-TN9
15	35	11	13,2	8,06	3,75	0,16	12 000	0,048	* ICOS-D1B02-TN9
17	40	12	14,2	9,95	4,75	0,2	11 000	0,071	* ICOS-D1B03-TN9
20	47	14	16,2	13,5	6,55	0,28	9 300	0,11	* ICOS-D1B04-TN9
25	52	15	17,2	14,8	7,8	0,335	7 700	0,14	* ICOS-D1B05-TN9
30	62	16	19,4	20,3	11,2	0,475	6 500	0,22	* ICOS-D1B06-TN9

* SKF Explorer bearing

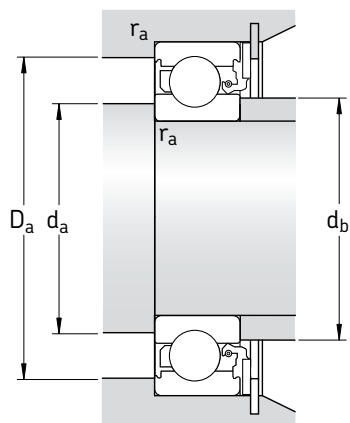

Dimensions					Abutment and fillet dimensions				Calculation factors	
d	d_1 ~	D_1 ~	D_2 ~	$r_{1,2}$ min	d_a max	d_b max	D_a max	r_a max	k_r	f_0
mm					mm				-	
12	18,4	- ¹⁾	27,4	0,6	16,2	18	27,8	0,6	0,025	12
15	21,7	30,8	30,4	0,6	19,2	21,5	30,8	0,6	0,025	13
17	24,5	35,6	35	0,6	21,2	24	35,8	0,6	0,025	13
20	28,8	42	40,6	1	25,6	28,5	41,4	1	0,025	13
25	34,3	47	46,3	1	30,6	34	46,4	1	0,025	14
30	40,3	55,6	54,1	1	35,6	40	56,4	1	0,025	14

¹⁾ Full rubber cross section

Single row deep groove ball bearings with snap ring groove
d 10 – 45 mm

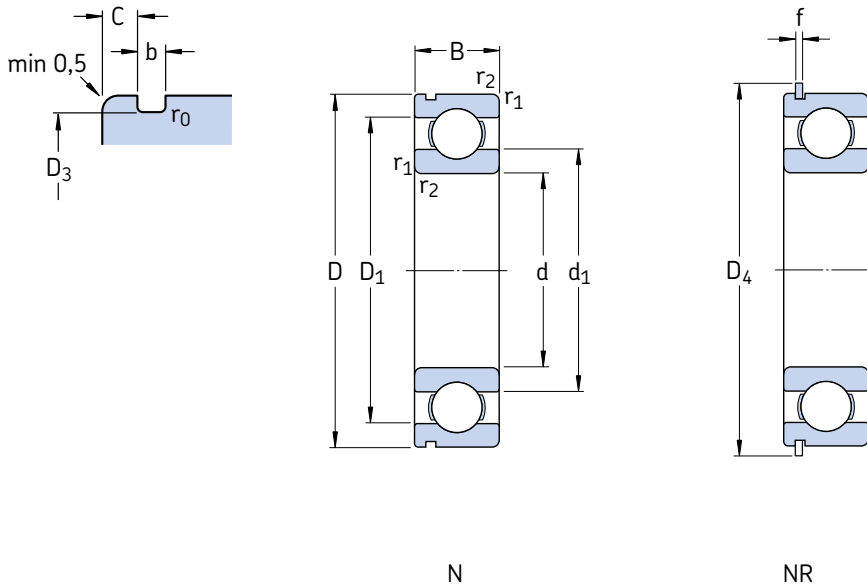

Principal dimensions			Basic load ratings		Fatigue load limit P_u	Speed ratings		Mass	Designations		
d	D	B	dynamic	static		Reference speed	Limiting speed		Bearing with snap ring groove	snap ring groove and snap ring	Snap ring
mm			kN		kN	r/min		kg	–		
10	30	9	5,4	2,36	0,1	56 000	34 000	0,032	* 6200 N	* 6200 NR	SP 30
12	32	10	7,28	3,1	0,132	50 000	32 000	0,037	* 6201 N	* 6201 NR	SP 32
15	35	11	8,06	3,75	0,16	43 000	28 000	0,045	* 6202 N	* 6202 NR	SP 35
17	40	12	9,95	4,75	0,2	38 000	24 000	0,065	* 6203 N	* 6203 NR	SP 40
	47	14	14,3	6,55	0,275	34 000	22 000	0,12	* 6303 N	* 6303 NR	SP 47
20	42	12	9,5	5	0,212	38 000	24 000	0,069	* 6004 N	* 6004 NR	SP 42
	47	14	13,5	6,55	0,28	32 000	20 000	0,11	* 6204 N	* 6204 NR	SP 47
	52	15	16,8	7,8	0,335	30 000	19 000	0,14	* 6304 N	* 6304 NR	SP 52
25	47	12	11,9	6,55	0,275	32 000	20 000	0,08	* 6005 N	* 6005 NR	SP 47
	52	15	14,8	7,8	0,335	28 000	18 000	0,13	* 6205 N	* 6205 NR	SP 52
	62	17	23,4	11,6	0,49	24 000	16 000	0,23	* 6305 N	* 6305 NR	SP 62
30	55	13	13,8	8,3	0,355	28 000	17 000	0,12	* 6006 N	* 6006 NR	SP 55
	62	16	20,3	11,2	0,475	24 000	15 000	0,20	* 6206 N	* 6206 NR	SP 62
	72	19	29,6	16	0,67	20 000	13 000	0,35	* 6306 N	* 6306 NR	SP 72
35	62	14	16,8	10,2	0,44	24 000	15 000	0,16	* 6007 N	* 6007 NR	SP 62
	72	17	27	15,3	0,655	20 000	13 000	0,29	* 6207 N	* 6207 NR	SP 72
40	80	21	35,1	19	0,815	19 000	12 000	0,46	* 6307 N	* 6307 NR	SP 80
	100	25	55,3	31	1,29	16 000	10 000	0,95	6407 N	6407 NR	SP 100
40	68	15	17,8	11,6	0,49	22 000	14 000	0,19	* 6008 N	* 6008 NR	SP 68
	80	18	32,5	19	0,8	18 000	11 000	0,37	* 6208 N	* 6208 NR	SP 80
45	90	23	42,3	24	1,02	17 000	11 000	0,63	* 6308 N	* 6308 NR	SP 90
	110	27	63,7	36,5	1,53	14 000	9 000	1,25	6408 N	6408 NR	SP 110
45	75	16	22,1	14,6	0,64	20 000	12 000	0,25	* 6009 N	* 6009 NR	SP 75
	85	19	35,1	21,6	0,915	17 000	11 000	0,41	* 6209 N	* 6209 NR	SP 85
45	100	25	55,3	31,5	1,34	15 000	9 500	0,83	* 6309 N	* 6309 NR	SP 100
	120	29	76,1	45	1,9	13 000	8 500	1,55	6409 N	6409 NR	SP 120

* SKF Explorer bearing

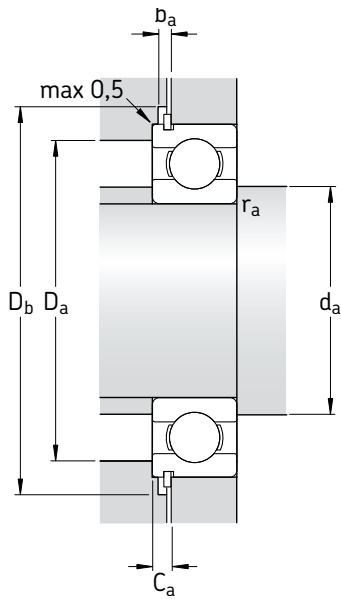

Dimensions										Abutment and fillet dimensions					Calculation factors		
d	d ₁	D ₁	D ₃	D ₄	b	f	C	r _{1,2} min	r ₀ max	d _a min	D _a max	D _b min	b _a min	C _a max	r _a max	k _r	f ₀
mm										mm					-		
10	17	23,2	28,17	34,7	1,35	1,12	2,06	0,6	0,4	14,2	25,8	36	1,5	3,18	0,6	0,025	13
12	18,5	25,7	30,15	36,7	1,35	1,12	2,06	0,6	0,4	16,2	27,8	38	1,5	3,18	0,6	0,025	12
15	21,7	29	33,17	39,7	1,35	1,12	2,06	0,6	0,4	19,2	30,8	41	1,5	3,18	0,6	0,025	13
17	24,5	32,7	38,1	44,6	1,35	1,12	2,06	0,6	0,4	21,2	35,8	46	1,5	3,18	0,6	0,025	13
	26,5	37,4	44,6	52,7	1,35	1,12	2,46	1	0,4	22,6	41,4	54	1,5	3,58	1	0,03	12
20	27,2	34,8	39,75	46,3	1,35	1,12	2,06	0,6	0,4	23,2	38,8	48	1,5	3,18	0,6	0,025	14
	28,8	38,5	44,6	52,7	1,35	1,12	2,46	1	0,4	25,6	41,4	54	1,5	3,58	1	0,025	13
	30,4	41,6	49,73	57,9	1,35	1,12	2,46	1,1	0,4	27	45	59	1,5	3,58	1	0,03	12
25	32	40	44,6	52,7	1,35	1,12	2,06	0,6	0,4	28,2	43,8	54	1,5	3,18	0,6	0,025	14
	34,4	44	49,73	57,9	1,35	1,12	2,46	1	0,4	30,6	46,4	59	1,5	3,58	1	0,025	14
	36,6	50,4	59,61	67,7	1,9	1,7	3,28	1,1	0,6	32	55	69	2,2	4,98	1	0,03	12
30	38,2	46,8	52,6	60,7	1,35	1,12	2,06	1	0,4	34,6	50,4	62	1,5	3,18	1	0,025	15
	40,4	51,6	59,61	67,7	1,9	1,7	3,28	1	0,6	35,6	56,4	69	2,2	4,98	1	0,025	14
	44,6	59,1	68,81	78,6	1,9	1,7	3,28	1,1	0,6	37	65	80	2,2	4,98	1	0,03	13
35	43,8	53,3	59,61	67,7	1,9	1,7	2,06	1	0,6	39,6	57,4	69	2,2	3,76	1	0,025	15
	46,9	60	68,81	78,6	1,9	1,7	3,28	1	0,6	40,6	66,4	80	2,2	4,98	1	0,025	14
	49,6	65,4	76,81	86,6	1,9	1,7	3,28	1,5	0,6	44	71	88	2,2	4,98	1,5	0,03	13
40	57,4	79,5	96,8	106,5	2,7	2,46	3,28	1,5	0,6	46	89	108	3	5,74	1,5	0,035	12
	49,3	58,8	64,82	74,6	1,9	1,7	2,49	1	0,6	44,6	63,4	76	2,2	4,19	1	0,025	15
	52,6	67,4	76,81	86,6	1,9	1,7	3,28	1,1	0,6	47	73	88	2,2	4,98	1	0,025	14
45	56,1	73,8	86,79	96,5	2,7	2,46	3,28	1,5	0,6	49	81	98	3	5,74	1,5	0,03	13
	62,8	87	106,81	116,6	2,7	2,46	3,28	2	0,6	53	97	118	3	5,74	2	0,035	12
	54,8	65,3	71,83	81,6	1,9	1,7	2,49	1	0,6	49,6	70,4	83	2,2	4,19	1	0,025	15
45	57,6	72,4	81,81	91,6	1,9	1,7	3,28	1,1	0,6	52	78	93	2,2	4,98	1	0,025	14
	62,2	82,7	96,8	106,5	2,7	2,46	3,28	1,5	0,6	54	91	108	3	5,74	1,5	0,03	13
	68,9	95,8	115,21	129,7	3,1	2,82	4,06	2	0,6	58	107	131	3,5	6,88	2	0,035	12

Single row deep groove ball bearings with snap ring groove
d 50 – 90 mm

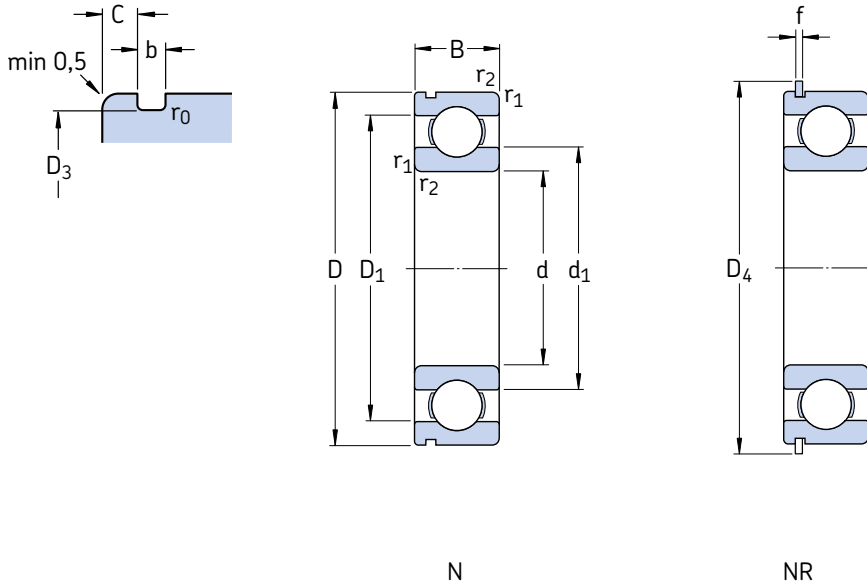

Principal dimensions			Basic load ratings		Fatigue load limit P_u	Speed ratings		Mass	Designations		
d	D	B	C	C_0		Reference speed	Limiting speed		Bearing with snap ring groove	snap ring groove and snap ring	Snap ring
mm			kN		kN	r/min		kg	–		
50	80	16	22,9	16	0,71	18 000	11 000	0,26	* 6010 N	* 6010 NR	SP 80
	90	20	37,1	23,2	0,98	15 000	10 000	0,46	* 6210 N	* 6210 NR	SP 90
	110	27	65	38	1,6	13 000	8 500	1,05	* 6310 N	* 6310 NR	SP 110
	130	31	87,1	52	2,2	12 000	7 500	1,90	6410 N	6410 NR	SP 130
55	90	18	29,6	21,2	0,9	16 000	10 000	0,39	* 6011 N	* 6011 NR	SP 90
	100	21	46,2	29	1,25	14 000	9 000	0,61	* 6211 N	* 6211 NR	SP 100
	120	29	74,1	45	1,9	12 000	8 000	1,35	* 6311 N	* 6311 NR	SP 120
	140	33	99,5	62	2,6	11 000	7 000	2,30	6411 N	6411 NR	SP 140
60	95	18	30,7	23,2	0,98	15 000	9 500	0,42	* 6012 N	* 6012 NR	SP 95
	110	22	55,3	36	1,53	13 000	8 000	0,78	* 6212 N	* 6212 NR	SP 110
	130	31	85,2	52	2,2	11 000	7 000	1,70	* 6312 N	* 6312 NR	SP 130
	150	35	108	69,5	2,9	10 000	6 300	2,75	6412 N	6412 NR	SP 150
65	100	18	31,9	25	1,06	14 000	9 000	0,44	* 6013 N	* 6013 NR	SP 100
	120	23	58,5	40,5	1,73	12 000	7 500	0,99	* 6213 N	* 6213 NR	SP 120
	140	33	97,5	60	2,5	10 000	6 700	2,10	* 6313 N	* 6313 NR	SP 140
	160	37	119	78	3,15	9 500	6 000	3,30	6413 N	6413 NR	SP 160
70	110	20	39,7	31	1,32	13 000	8 000	0,60	* 6014 N	* 6014 NR	SP 110
	125	24	63,7	45	1,9	11 000	7 000	1,05	* 6214 N	* 6214 NR	SP 125
	150	35	111	68	2,75	9 500	6 300	2,50	* 6314 N	* 6314 NR	SP 150
75	115	20	41,6	33,5	1,43	12 000	7 500	0,64	* 6015 N	* 6015 NR	SP 115
	130	25	68,9	49	2,04	10 000	6 700	1,20	* 6215 N	* 6215 NR	SP 130
	160	37	119	76,5	3	9 000	5 600	3,00	* 6315 N	* 6315 NR	SP 160
80	125	22	49,4	40	1,66	11 000	7 000	0,85	* 6016 N	* 6016 NR	SP 125
	140	26	72,8	55	2,2	9 500	6 000	1,40	* 6216 N	* 6216 NR	SP 140
85	130	22	52	43	1,76	11 000	6 700	0,89	* 6017 N	* 6017 NR	SP 130
	150	28	87,1	64	2,5	9 000	5 600	1,80	* 6217 N	* 6217 NR	SP 150
90	140	24	60,5	50	1,96	10 000	6 300	1,15	* 6018 N	* 6018 NR	SP 140
	160	30	101	73,5	2,8	8 500	5 300	2,15	* 6218 N	* 6218 NR	SP 160

* SKF Explorer bearing

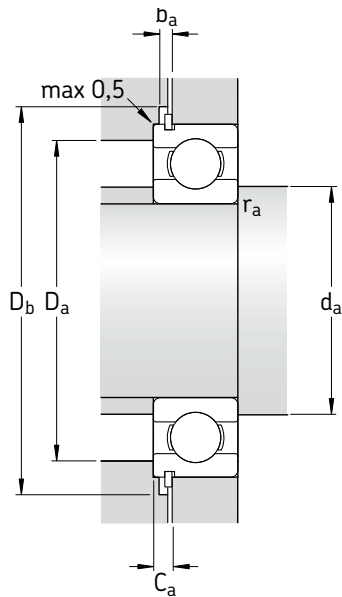

Dimensions										Abutment and fillet dimensions						Calculation factors	
d	d ₁	D ₁	D ₃	D ₄	b	f	C	r _{1,2} min	r ₀ max	d _a min	D _a max	D _b min	b _a min	C _a max	r _a max	k _r	f ₀
mm										mm						-	
50	59,8	70,3	76,81	86,6	1,9	1,7	2,49	1	0,6	54,6	75,4	88	2,2	4,19	1	0,025	15
	62,5	77,4	86,79	96,5	2,7	2,46	3,28	1,1	0,6	57	83	98	3	5,74	1	0,025	14
55	68,8	91,1	106,81	116,6	2,7	2,46	3,28	2	0,6	61	99	118	3	5,74	2	0,03	13
	75,5	104	125,22	139,7	3,1	2,82	4,06	2,1	0,6	64	116	141	3,5	6,88	2	0,035	12
60	71,3	83,7	91,82	101,6	2,7	2,46	2,87	1,1	0,6	66	87	103	3	5,33	1	0,025	16
	75,5	94,6	106,81	116,6	2,7	2,46	3,28	1,5	0,6	69	101	118	3	5,74	1,5	0,025	14
65	81,9	108	125,22	139,7	3,1	2,82	4,06	2,1	0,6	72	118	141	3,5	6,88	2	0,03	13
	88,1	122	145,24	159,7	3,1	2,82	4,9	2,1	0,6	74	136	162	3,5	7,72	2	0,035	12
70	76,3	88,7	96,8	106,5	2,7	2,46	2,87	1,1	0,6	71	94	108	3	5,33	1	0,025	16
	83,3	102	115,21	129,7	3,1	2,82	4,06	1,5	0,6	74	111	131	3,5	6,88	1,5	0,025	15
75	88,4	116	135,23	149,7	3,1	2,82	4,9	2,1	0,6	77	128	151	3,5	7,72	2	0,03	13
	94	131	155,22	169,7	3,1	2,82	4,9	2,1	0,6	79	146	172	3,5	7,72	2	0,035	12
80	82,9	97,2	106,81	116,6	2,7	2,46	2,87	1,1	0,6	76	104	118	3	5,33	1	0,025	16
	87,1	108	120,22	134,7	3,1	2,82	4,06	1,5	0,6	79	116	136	3,5	6,88	1,5	0,025	15
85	92,1	113	125,22	139,7	3,1	2,82	4,06	1,5	0,6	84	121	141	3,5	6,88	1,5	0,025	15
	101	133	155,22	169,7	3,1	2,82	4,9	2,1	0,6	87	148	172	3,5	7,72	2	0,03	13
90	94,4	111	120,22	134,7	3,1	2,82	2,87	1,1	0,6	86	119	136	3,5	5,69	1	0,025	16
	101	122	135,23	149,7	3,1	2,82	4,9	2	0,6	91	129	151	3,5	7,72	2	0,025	15
95	99,4	116	125,22	139,7	3,1	2,82	2,87	1,1	0,6	91	124	141	3,5	5,69	1	0,025	16
	106	130	145,24	159,7	3,1	2,82	4,9	2	0,6	96	139	162	3,5	7,72	2	0,025	15
100	106	124	135,23	149,7	3,1	2,82	3,71	1,5	0,6	97	133	151	3,5	6,53	1,5	0,025	16
	113	138	155,22	169,7	3,1	2,82	4,9	2	0,6	101	149	172	3,5	7,72	2	0,025	15

Single row deep groove ball bearings with snap ring groove
d 95 – 120 mm

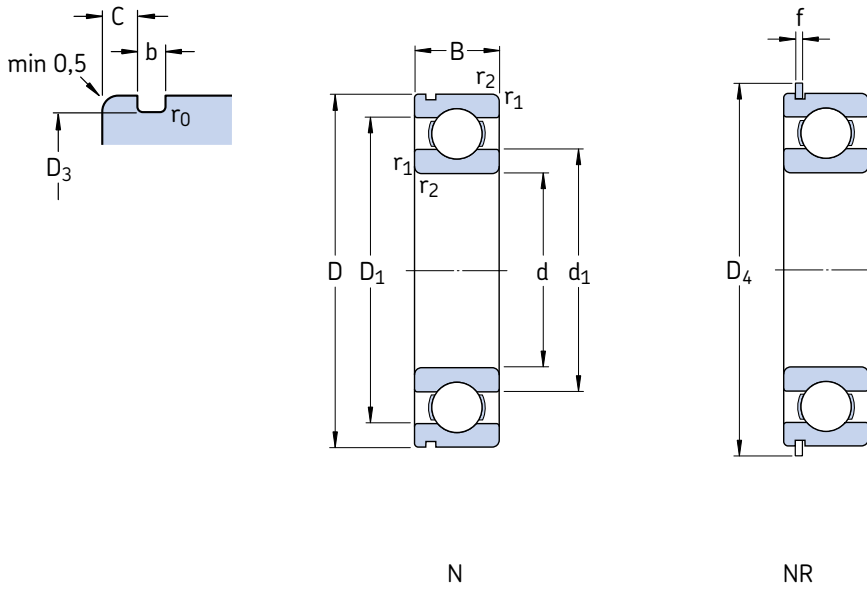

Principal dimensions			Basic load ratings		Fatigue load limit P_u	Speed ratings		Mass	Designations		
d	D	B	dynamic	static		Reference speed	Limiting speed		Bearing with snap ring groove	snap ring groove and snap ring	Snap ring
mm			kN		kN	r/min		kg	–		
95	170	32	114	81,5	3	8 000	5 000	2,60	* 6219 N	* 6219 NR	SP 170
100	150	24	63,7	54	2,04	9 500	5 600	1,25	* 6020 N	* 6020 NR	SP 150
	180	34	127	93	3,35	7 500	4 800	3,15	* 6220 N	* 6220 NR	SP 180
105	160	26	76,1	65,5	2,4	8 500	5 300	1,60	* 6021 N	* 6021 NR	SP 160
110	170	28	85,2	73,5	2,6	8 000	5 000	1,95	* 6022 N	* 6022 NR	SP 170
120	180	28	88,4	80	2,75	7 500	4 800	2,05	* 6024 N	* 6024 NR	SP 180

* SKF Explorer bearing

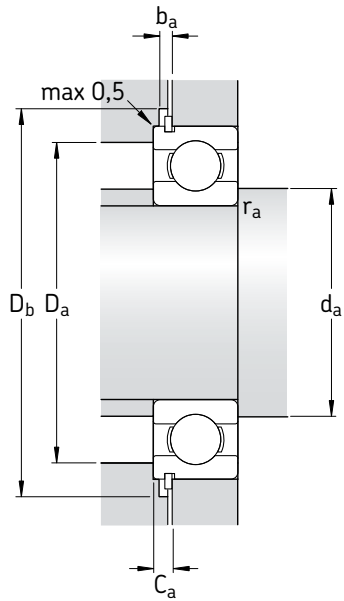

Dimensions										Abutment and fillet dimensions					Calculation factors		
d	\tilde{d}_1	\tilde{D}_1	D ₃	D ₄	b	f	C	r _{1,2} min	r ₀ max	d _a min	D _a max	D _b min	b _a min	C _a max	r _a max	k _r	f ₀
mm										mm					-		
95	118	146	163,65	182,9	3,5	3,1	5,69	2,1	0,6	107	158	185	4	8,79	2	0,025	14
100	116 125	134 155	145,24 173,66	159,7 192,9	3,1 3,5	2,82 3,1	3,71 5,69	1,5 2,1	0,6 0,6	107 112	143 168	162 195	3,5 4	6,53 8,79	1,5 2	0,025 0,025	16 14
105	123	143	155,22	169,7	3,1	2,82	3,71	2	0,6	114	151	172	3,5	6,53	2	0,025	16
110	129	151	163,65	182,9	3,5	3,1	3,71	2	0,6	119	161	185	4	6,81	2	0,025	16
120	139	161	173,66	192,9	3,5	3,1	3,71	2	0,6	129	171	195	4	6,81	2	0,025	16

Single row deep groove ball bearings with snap ring groove and shields

d 10 – 60 mm

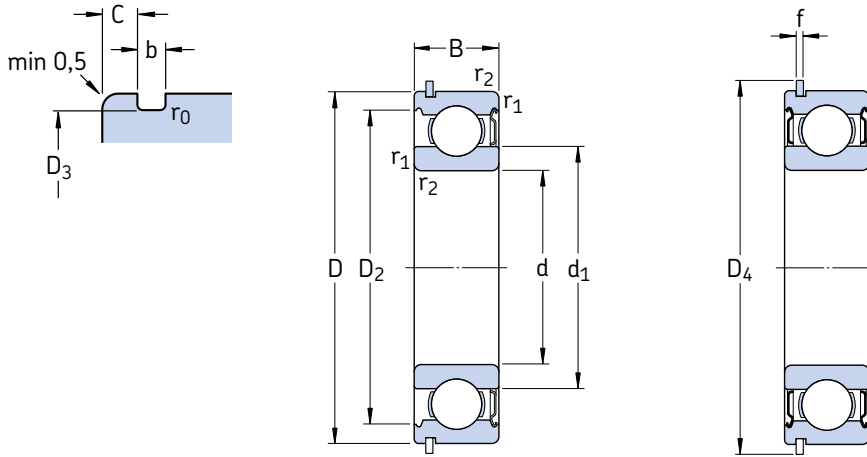

ZNR

ZZNR

Principal dimensions			Basic load ratings		Fatigue load limit P_u	Speed ratings		Mass	Designations		Snap ring
d	D	B	dynamic	static		Reference speed	Limiting speed ¹⁾		Bearing with one shield and snap ring	two shields and snap ring	
mm			kN		kN	r/min		kg	–		
10	30	9	5,4	2,36	0,1	56 000	34 000	0,032	* 6200-ZNR	* 6200-ZZNR	SP 30
12	32	10	7,28	3,1	0,132	5 0000	32 000	0,037	* 6201-ZNR	* 6201-ZZNR	SP 32
15	35	11	8,06	3,75	0,16	43 000	28 000	0,045	* 6202-ZNR	* 6202-ZZNR	SP 35
17	40	12	9,95	4,75	0,2	38 000	24 000	0,065	* 6203-ZNR	* 6203-ZZNR	SP 40
	47	14	14,3	6,55	0,275	34 000	22 000	0,12	* 6303-ZNR	* 6303-ZZNR	SP 47
20	42	12	9,95	5	0,212	38 000	24 000	0,069	* 6004-ZNR	* 6004-ZZNR	SP 42
	47	14	13,5	6,55	0,28	32 000	20 000	0,11	* 6204-ZNR	* 6204-ZZNR	SP 47
	52	15	16,8	7,8	0,335	3 0000	19 000	0,14	* 6304-ZNR	* 6304-ZZNR	SP 52
25	47	12	11,9	6,55	0,275	32 000	20 000	0,08	* 6005-ZNR	* 6005-ZZNR	SP 47
	52	15	14,8	7,8	0,335	28 000	18 000	0,13	* 6205-ZNR	* 6205-ZZNR	SP 52
	62	17	23,4	11,6	0,49	24 000	16 000	0,23	* 6305-ZNR	* 6305-ZZNR	SP 62
30	62	16	20,3	11,2	0,475	24 000	15 000	0,20	* 6206-ZNR	* 6206-ZZNR	SP 62
	72	19	29,6	16	0,67	2 0000	13 000	0,35	* 6306-ZNR	* 6306-ZZNR	SP 72
35	72	17	27	15,3	0,655	2 0000	13 000	0,29	* 6207-ZNR	* 6207-ZZNR	SP 72
	80	21	35,1	19	0,815	19 000	12 000	0,46	* 6307-ZNR	* 6307-ZZNR	SP 80
40	80	18	32,5	19	0,8	18 000	11 000	0,37	* 6208-ZNR	* 6208-ZZNR	SP 80
	90	23	42,3	24	1,02	17 000	11 000	0,63	* 6308-ZNR	* 6308-ZZNR	SP 90
45	85	19	35,1	21,6	0,915	17 000	11 000	0,41	* 6209-ZNR	* 6209-ZZNR	SP 85
	100	25	55,3	31,5	1,34	15 000	9 500	0,83	* 6309-ZNR	* 6309-ZZNR	SP 100
50	90	20	37,1	23,2	0,98	15 000	10 000	0,46	* 6210-ZNR	* 6210-ZZNR	SP 90
	110	27	65	38	1,6	13 000	8 500	1,05	* 6310-ZNR	* 6310-ZZNR	SP 110
55	100	21	46,2	29	1,25	14 000	9 000	0,61	* 6211-ZNR	* 6211-ZZNR	SP 100
	120	29	74,1	45	1,9	12 000	8 000	1,35	* 6311-ZNR	* 6311-ZZNR	SP 120
60	110	22	55,3	36	1,53	13 000	8 000	0,78	* 6212-ZNR	* 6212-ZZNR	SP 110
	130	31	85,2	52	2,2	11 000	7 000	1,70	* 6312-ZNR	* 6312-ZZNR	SP 130

* SKF Explorer bearing

¹⁾ For ZZ design, limiting speeds are about 80 % of the quoted value

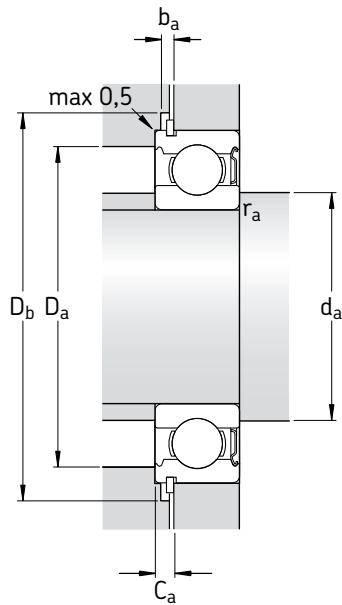

Dimensions										Abutment and fillet dimensions						Calculation factors	
d	d ₁	D ₂	D ₃	D ₄	b	f	C	r _{1,2} min	r ₀ max	d _a min	D _a max	D _b min	b _a min	C _a max	r _a max	k _r	f ₀
mm										mm						-	
10	17	24,8	28,17	34,7	1,35	1,12	2,06	0,6	0,4	14,2	25,8	36	1,5	3,18	0,6	0,025	13
12	18,5	27,4	30,15	36,7	1,35	1,12	2,06	0,6	0,4	16,2	27,8	38	1,5	3,18	0,6	0,025	12
15	21,7	30,4	33,17	39,7	1,35	1,12	2,06	0,6	0,4	19,2	30,8	41	1,5	3,18	0,6	0,025	13
17	24,5	35	38,1	44,6	1,35	1,12	2,06	0,6	0,4	21,2	35,8	46	1,5	3,18	0,6	0,025	13
	26,5	39,7	44,6	52,7	1,35	1,12	2,46	1	0,4	22,6	41,4	54	1,5	3,58	1	0,03	12
20	27,2	37,2	39,75	46,3	1,35	1,12	2,06	0,6	0,4	23,2	38,8	48	1,5	3,18	0,6	0,025	14
	28,8	40,6	44,6	52,7	1,35	1,12	2,46	1	0,4	25,6	41,4	54	1,5	3,58	1	0,025	13
	30,4	44,8	49,73	57,9	1,35	1,12	2,46	1,1	0,4	27	45	59	1,5	3,58	1	0,03	12
25	32	42,2	44,6	52,7	1,35	1,12	2,06	0,6	0,4	28,2	43,8	54	1,5	3,18	0,6	0,025	14
	34,4	46,3	49,73	57,9	1,35	1,12	2,46	1	0,4	30,6	46,4	59	1,5	3,58	1	0,025	14
	36,6	52,7	59,61	67,7	1,9	1,7	3,28	1,1	0,6	32	55	69	2,2	4,98	1	0,03	12
30	40,4	54,1	59,61	67,7	1,9	1,7	3,28	1	0,6	35,6	56,4	69	2,2	4,98	1	0,025	14
	44,6	61,9	68,81	78,6	1,9	1,7	3,28	1,1	0,6	37	65	80	2,2	4,98	1	0,03	13
35	46,9	62,7	68,81	78,6	1,9	1,7	3,28	1	0,6	40,6	66,4	80	2,2	4,98	1	0,025	14
	49,6	69,2	76,81	86,6	1,9	1,7	3,28	1,5	0,6	44	71	88	2,2	4,98	1,5	0,03	13
40	52,6	69,8	76,81	86,6	1,9	1,7	3,28	1,1	0,6	47	73	88	2,2	4,98	1	0,025	14
	56,1	77,7	86,79	96,5	2,7	2,46	3,28	1,5	0,6	49	81	98	3	5,74	1,5	0,03	13
45	57,6	75,2	81,81	91,6	1,9	1,7	3,28	1,1	0,6	52	78	93	2,2	4,98	1	0,025	14
	62,2	86,7	96,8	106,5	2,7	2,46	3,28	1,5	0,6	54	91	108	3	5,74	1,5	0,03	13
50	62,5	81,6	86,79	96,5	2,7	2,46	3,28	1,1	0,6	57	83	98	3	5,74	1	0,025	14
	68,8	95,2	106,81	116,6	2,7	2,46	3,28	2	0,6	61	99	118	3	5,74	2	0,03	13
55	69,1	89,4	96,8	106,5	2,7	2,46	3,28	1,5	0,6	64	91	108	3	5,74	1,5	0,025	14
	75,3	104	115,21	129,7	3,1	2,82	4,06	2	0,6	66	109	131	3,5	6,88	2	0,03	13
60	75,5	98	106,81	116,6	2,7	2,46	3,28	1,5	0,6	69	101	118	3	5,74	1,5	0,025	14
	81,9	112	125,22	139,7	3,1	2,82	4,06	2,1	0,6	72	118	141	3,5	6,88	2	0,03	13

Single row deep groove ball bearings with snap ring and shields

d 65 – 70 mm

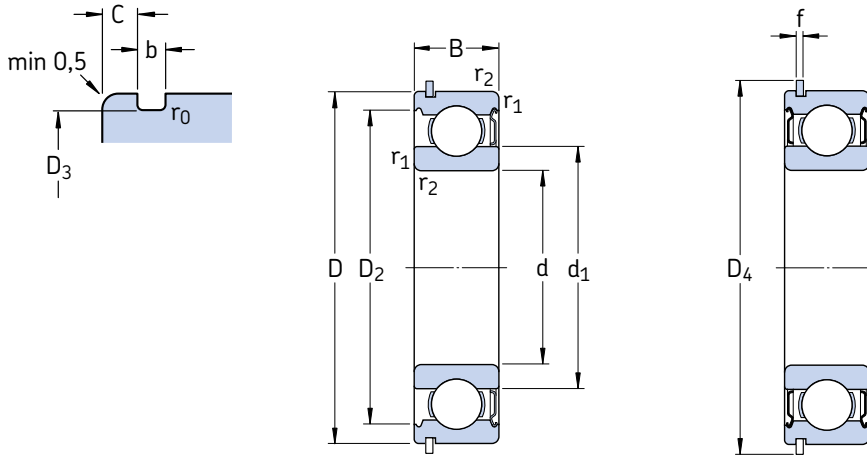

ZNR

2ZNR

Principal dimensions			Basic load ratings		Fatigue load limit P_u	Speed ratings		Mass	Designations		Snap ring
d	D	B	dynamic	static C_0		Reference speed	Limiting speed ¹⁾		Bearing with one shield and snap ring	two shields and snap ring	
mm			kN		kN	r/min		kg	–		
65	120	23	58,5	40,5	1,73	12 000	7 500	0,99	* 6213-ZNR	* 6213-2ZNR	SP 120
	140	33	97,5	60	2,5	1 0000	6 700	2,10	* 6313-ZNR	* 6313-2ZNR	SP 140
70	125	24	63,7	45	1,9	11 000	7 000	1,05	* 6214-ZNR	* 6214-2ZNR	SP 125
	150	35	111	68	2,75	9 500	6 300	2,50	* 6314-ZNR	* 6314-2ZNR	SP 150

* SKF Explorer bearing

¹⁾ For 2Z design, limiting speeds are about 80 % of the quoted value

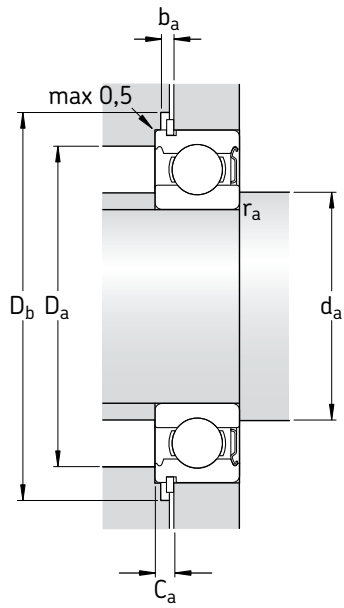

Dimensions										Abutment and fillet dimensions					Calculation factors		
d	d_1	D_2	D_3	D_4	b	f	C	$r_{1,2}$ min	r_0 max	d_a min	D_a max	D_b min	b_a min	C_a max	r_a max	k_r	f_0
mm										mm					-		
65	83,3	106	115,21	129,7	3,1	2,82	4,06	1,5	0,6	74	111	131	3,5	6,88	1,5	0,025	15
	88,4	121	135,23	149,7	3,1	2,82	4,9	2,1	0,6	77	128	151	3,5	7,72	2	0,03	13
70	87,1	111	120,22	134,7	3,1	2,82	4,06	1,5	0,6	79	116	136	3,5	6,88	1,5	0,025	15
	95	130	145,24	159,7	3,1	2,82	4,9	2,1	0,6	82	138	162	3,5	7,72	2	0,03	13



Single row deep groove ball bearings with filling slots

Designs	362
Basic design bearings	362
Shielded bearings.....	362
Bearings with a snap ring groove.....	363
Bearing data – general	363
Dimensions.....	363
Tolerances.....	363
Internal clearance.....	363
Misalignment	364
Cages.....	364
Minimum load	364
Equivalent dynamic bearing load	364
Equivalent static bearing load	364
Supplementary designations	365
Product tables	366
Single row deep groove ball bearings with filling slots	366
Single row deep groove ball bearings with filling slots and snap ring	370

Designs

A single row deep groove ball bearing with filling slots has a filling slot in both the inner and outer rings (→ **fig. 1**) enabling more and larger balls to be incorporated than in standard deep groove ball bearings. Filling slot bearings have a higher radial load carrying capacity than bearings without filling slots, but their axial load carrying capacity is small. They are also unable to operate at such high speeds as bearings without filling slots.

The standard assortment of SKF deep groove ball bearings with filling slots comprises

- basic design open bearings
- shielded bearings
- bearings with a snap ring groove.

Basic design bearings

Basic design bearings with filling slots are open. Those bearings that are also produced in shielded version may have seal recesses in the outer ring, for manufacturing reasons (→ **fig. 2**).

Shielded bearings

SKF deep groove ball bearings with filling slots are available with shields on one or both sides, designation suffixes Z or 2Z. The shield forms a narrow gap to the inner ring shoulder (→ **fig. 3**).

Bearings up to and including sizes 217 and 314 are filled with a high-quality NLGI class 2 grease with polyurea thickener, for a temperature range of -30 to $+150$ °C. The base oil viscosity is $115 \text{ mm}^2/\text{s}$ at 40 °C and $12,2 \text{ mm}^2/\text{s}$ at 100 °C.

Larger bearings are supplied with a high-quality NLGI class 3 grease with lithium thickener, for a temperature range of -30 to $+120$ °C. The base oil viscosity is $98 \text{ mm}^2/\text{s}$ at 40 °C and $9,4 \text{ mm}^2/\text{s}$ at 100 °C.

The quantity of grease fills some 25 to 35 % of the free space in the bearing. The bearings are lubricated for life and are maintenance-free. They should therefore not be washed or heated above 80 °C before mounting.

Fig. 1

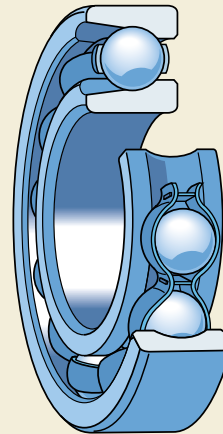

Fig. 2

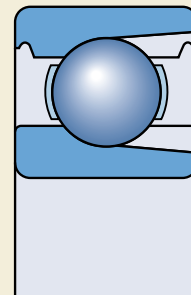
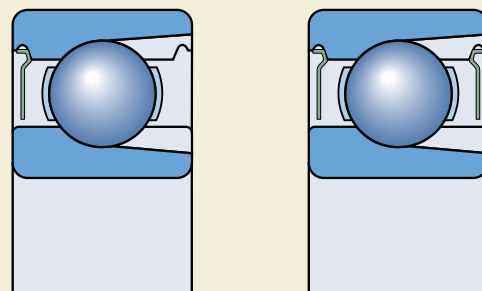

Fig. 3



Bearings with a snap ring groove

For easy, space saving axial location of the bearing in the housing, SKF deep groove ball bearings with filling slots are available with a snap ring groove in the outer ring, designation suffix N (→ **fig. 4a**). The appropriate snap ring is shown in the product table with designation and dimensions and may be supplied separately or already mounted on the bearing, designation suffix NR (→ **fig. 4b**). SKF deep groove ball bearings with filling slots and a snap ring groove can also be supplied with a shield on the side opposite the snap ring groove (→ **fig. 5a**) or with two shields (→ **fig. 5b**).

Bearing data – general

Dimensions

The boundary dimensions of SKF deep groove ball bearings with filling slots are in accordance with ISO 15:1998.

The dimensions of the snap ring groove and snap rings follow ISO 464:1995.

Tolerances

SKF deep groove ball bearings with filling slots are produced to Normal tolerances. The tolerances are in accordance with ISO 492:2002 and can be found in **table 3** on **page 125**.

Internal clearance

SKF single row deep groove ball bearings with filling slots are manufactured with Normal radial internal clearance. The values for radial internal clearance are provided in **table 3** on **page 297**. They are in accordance with ISO 5753:1991 and are valid for unmounted bearings under zero measuring load.

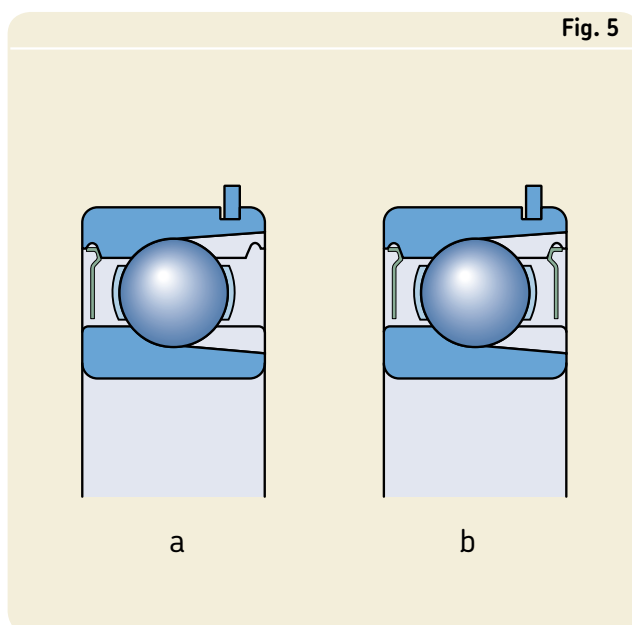
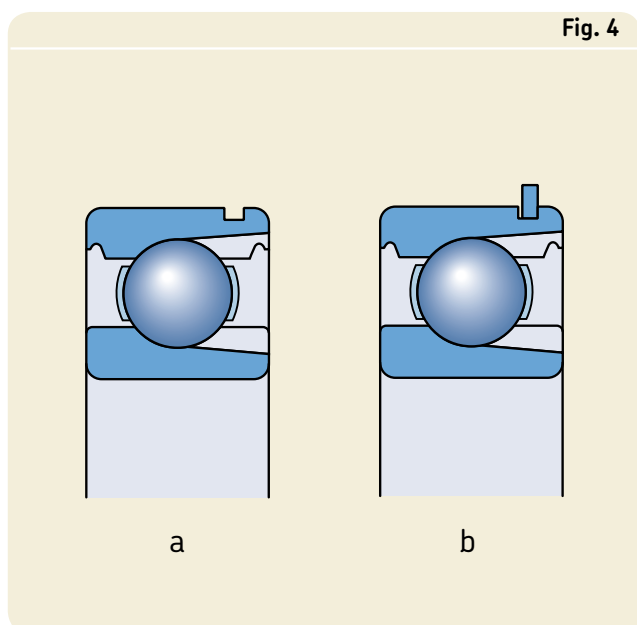

Single row deep groove ball bearings with filling slots

Misalignment

The conditions concerning misalignment of the outer ring with respect to the inner ring are the same for deep groove ball bearings with filling slots as for standard bearings. However, the filling slots limit the angular misalignment to 2 to 5 minutes of arc. Any greater misalignment may lead to the balls running over the edges of the filling slot. This will cause increased bearing noise and reduced bearing service life.

Cages

SKF deep groove ball bearings with filling slots are fitted with a pressed riveted steel cage, ball centred, no designation suffix (→ **fig. 6**).

Minimum load

In order to provide satisfactory operation, deep groove ball bearings with filling slots, like all ball and roller bearings, must always be subjected to a given minimum load, particularly if they are to operate at high speeds or are subjected to high accelerations or rapid changes in the direction of load. Under such conditions, the inertia forces of the balls and cage, and the friction in the lubricant, can have a detrimental influence on the rolling conditions in the bearing arrangement and may cause damaging sliding movements to occur between the balls and raceways.

The requisite minimum radial load to be applied to deep groove ball bearings with filling slots can be estimated using

$$F_{rm} = k_r \left(\frac{v n}{1\,000} \right)^{2/3} \left(\frac{d_m}{100} \right)^2$$

where

F_{rm} = minimum radial load, kN

k_r = minimum load factor

0,04 for bearings in the 2 series

0,05 for bearings in the 3 series

v = oil viscosity at operating temperature, mm^2/s

n = rotational speed, r/min

d_m = bearing mean diameter
= 0,5 (d + D), mm

When starting up at low temperatures or when the lubricant is highly viscous, even greater minimum loads may be required. The weight of the components supported by the bearing, together with external forces, generally exceeds the requisite minimum load. If this is not the case, the deep groove ball bearing must be subjected to an additional radial load.

Equivalent dynamic bearing load

$$P = F_r + F_a$$

provided $F_a/F_r \leq 0,6$ and $P \leq 0,5 C_0$.

If the axial load $F_a > 0,6 F_r$ then deep groove ball bearings with filling slots are unsuitable for the application and bearings without filling slots should be used instead.

Equivalent static bearing load

$$P_0 = F_r + 0,5 F_a$$

provided $F_a/F_r \leq 0,6$.

Fig. 6

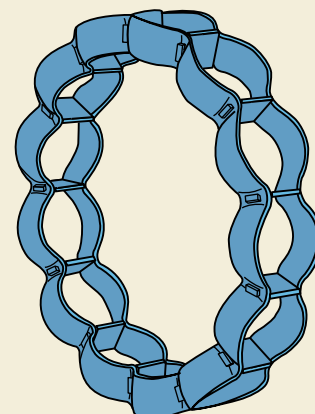

Supplementary designations

The designation suffixes used to identify certain features of SKF deep groove ball bearings with filling slots are explained in the following.

- C3** Radial internal clearance greater than Normal
- N** Snap ring groove in the outer ring
- NR** Snap ring groove in the outer ring, with appropriate snap ring
- Z** Shield of pressed sheet steel on one side of the bearing
- 2Z** Z shield on both sides of the bearing
- ZNR** Shield of pressed sheet steel on one side of the bearing and snap ring groove in the outer ring with snap ring on the opposite side of the shield
- 2ZNR** Z shield on both sides of the bearing and snap ring groove in the outer ring with snap ring

Single row deep groove ball bearings with filling slots

d 25 – 85 mm

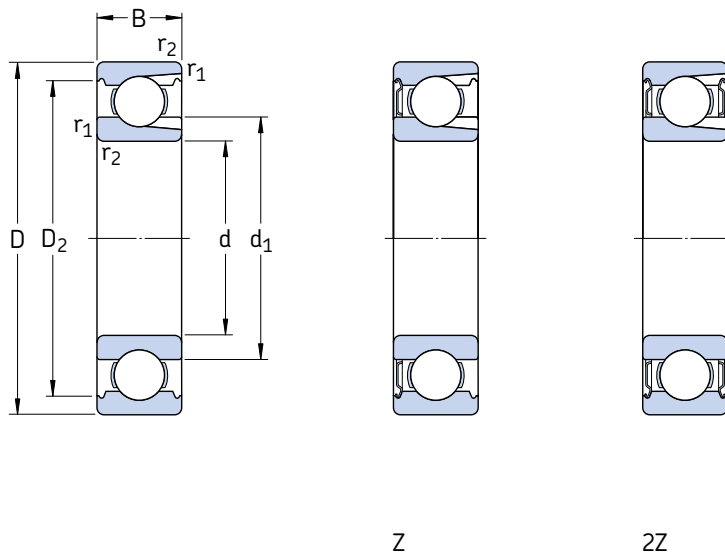

Principal dimensions			Basic load ratings		Fatigue load limit P_u	Speed ratings		Mass	Designations		
d	D	B	C	C_0		Reference speed	Limiting speed ¹⁾		Bearing open	with shields on one side	two sides
mm			kN		kN	r/min		kg	–		
25	62	17	22,9	15,6	0,67	20 000	13 000	0,24	305	305-Z	305-2Z
	72	19	29,2	20,8		18 000	11 000				
30	62	16	22,9	17,3	0,735	20 000	12 000	0,21	306	306-Z	306-2Z
	72	19	29,2	20,8		18 000	11 000				
35	72	17	29,7	22,8	0,965	17 000	11 000	0,31	207	207-Z	207-2Z
	80	21	39,1	28,5		16 000	10 000				
40	80	18	33,6	26,5	1,12	15 000	9 500	0,39	208	208-Z	208-2Z
	90	23	46,8	36		14 000	9 000				
45	85	19	39,6	32,5	1,37	14 000	9 000	0,44	209	209-Z	209-2Z
	100	25	59,4	46,5		13 000	8 000				
50	90	20	39,1	34,5	1,46	13 000	8 000	0,5	210	210-Z	210-2Z
	110	27	64,4	52		11 000	7 000				
55	100	21	48,4	44	1,86	12 000	7 500	0,66	211	211-Z	211-2Z
	120	29	79,2	67		10 000	6 700				
60	110	22	56,1	50	2,12	11 000	6 700	0,85	212	212-Z	212-2Z
	130	31	91,3	78		9 500	6 000				
65	120	23	60,5	58,5	2,5	10 000	6 000	1,05	213	213-Z	213-2Z
	140	33	102	90		9 000	5 600				
70	125	24	66	65,5	2,75	9 500	6 000	1,15	214	214-Z	214-2Z
	150	35	114	102		8 000	5 000				
75	130	25	72,1	72	3	9 000	5 600	1,25	215	215-Z	215-2Z
	160	37	125	116		7 500	4 800				
80	140	26	88	85	3,45	8 500	5 300	1,55	216	216-Z	216-2Z
	170	39	138	129		7 000	4 500				
85	150	28	96,8	100	3,9	7 500	4 800	1,95	217	217-Z	217-2Z
	180	41	147	146		6 700	4 300				

¹⁾For 2Z design, limiting speeds are about 80 % of the quoted value

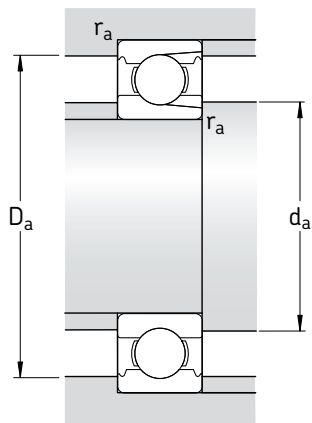

Dimensions				Abutment and fillet dimensions		
d	d_1 ~	D_2 ~	$r_{1,2}$ min	d_a min	D_a max	r_a max
mm				mm		
25	32,8	52,7	1,1	31,5	55,5	1
30	36,2 43,9	54,1 61,9	1 1,1	35 36,5	57 65,5	1 1
35	41,7 43,7	62,7 69,2	1,1 1,5	41,5 43	65,5 72	1 1,5
40	48,9 50,5	69,8 77,7	1,1 1,5	46,5 48	73,5 82	1 1,5
45	52,5 55,9	75,2 86,7	1,1 1,5	51,5 53	78,5 92	1 1,5
50	57,5 67,5	81,7 95,2	1,1 2	56,5 61	83,5 99	1 2
55	63,1 74	89,4 104	1,5 2	63 64	92 111	1,5 2
60	70,1 80,3	97 113	1,5 2,1	68 71	102 119	1,5 2
65	83,3 86,8	106 122	1,5 2,1	73 76	112 129	1,5 2
70	87,1 93,2	111 130	1,5 2,1	78 81	117 139	1,5 2
75	92,1 99,7	117 139	1,5 2,1	83 86	122 149	1,5 2
80	88,8 106	127 147	2 2,1	89 91	131 159	2 2
85	97 113	135 156	2 3	96 98	139 167	2 2,5

Single row deep groove ball bearings with filling slots
d 90 – 100 mm

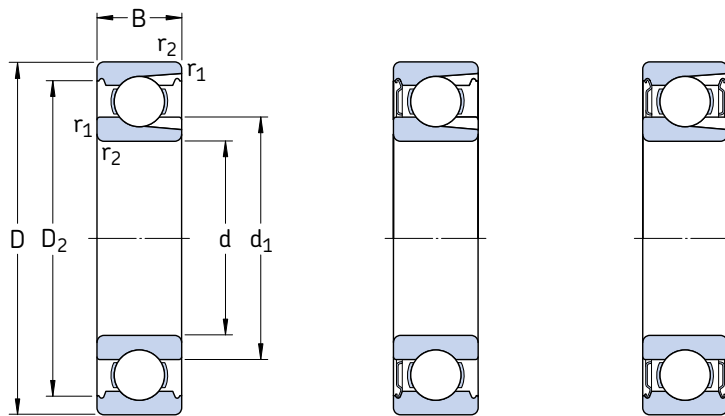

Z

2Z

Principal dimensions			Basic load ratings		Fatigue load limit P_u	Speed ratings		Mass	Designations		
d	D	B	dynamic C	static C_0		Reference speed	Limiting speed ¹⁾		Bearing open	with shields on one side	two sides
mm			kN		kN	r/min		kg	–		
90	160	30	112	114	4,3	7 000	4 500	2,35	218	218-Z	218-2Z
	190	43	157	160	5,7	6 300	4 000	5,40	318	318-Z	318-2Z
95	170	32	121	122	4,5	6 700	4 300	2,70	219	219-Z	219-2Z
100	180	34	134	140	5	6 300	4 000	3,45	220	220-Z	220-2Z

¹⁾For 2Z design, limiting speeds are about 80 % of the quoted value

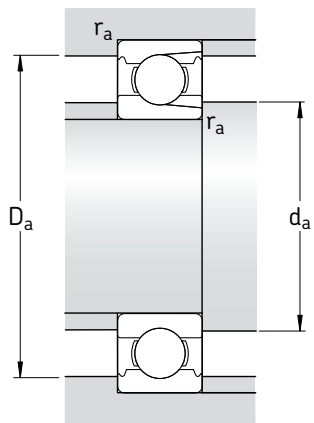

Dimensions

Abutment and fillet dimensions

d	d_1 ~	D_2 ~	$r_{1,2}$ min	d_a min	D_a max	r_a max
mm				mm		
90	110 119	143 164	2 3	99 103	151 177	2 2,5
95	117	152	2,1	107	158	2
100	123	160	2,1	112	168	2

Single row deep groove ball bearings with filling slots and snap ring

d 25 – 95 mm

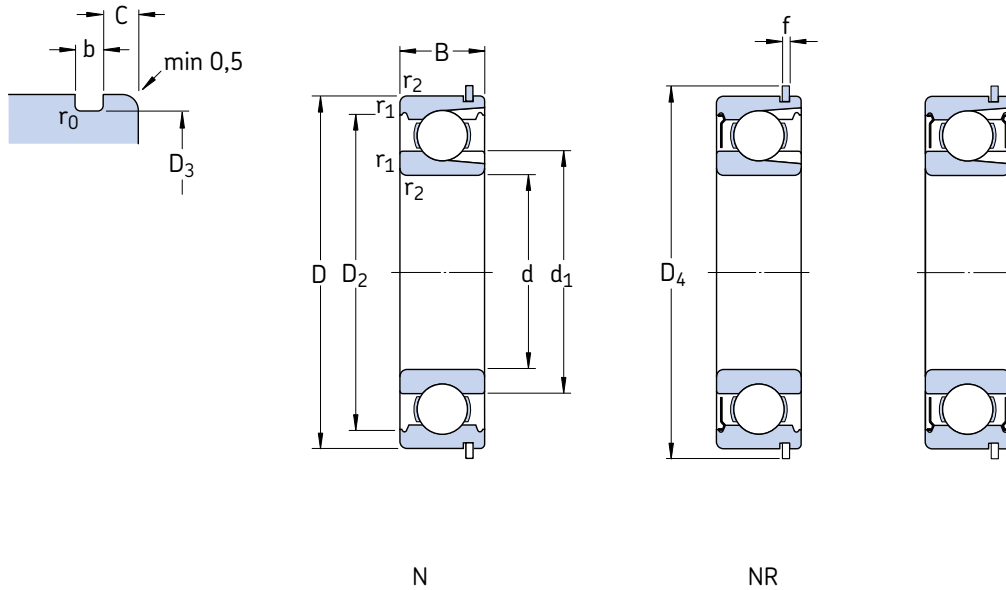

Principal dimensions			Basic load ratings		Fatigue load limit P_u	Speed ratings		Mass	Designations			Snap ring
d	D	B	dynamic C	static C_0		Reference speed	Limiting speed ¹⁾		Bearing open	with shields on one side	with shields on two sides	
mm			kN		kN	r/min		kg	–			
25	62	17	23	16	1	20 000	13 000	0,24	305 NR	305-ZNR	305-2ZNR	SP 62
30	62	16	22,9	17,3	0,735	20 000	12 000	0,21	206 NR	206-ZNR	206-2ZNR	SP 62
	72	19	29,2	20,8	0,88	18 000	11 000	0,37	306 NR	306-ZNR	306-2ZNR	SP 72
35	72	17	29,7	22,8	0,965	17 000	11 000	0,31	207 NR	207-ZNR	207-2ZNR	SP 72
	80	21	39,1	28,5	1,2	16 000	10 000	0,48	307 NR	307-ZNR	307-2ZNR	SP 80
40	80	18	33,6	26,5	1,12	15 000	9 500	0,39	208 NR	208-ZNR	208-2ZNR	SP 80
	90	23	46,8	36	1,53	14 000	9 000	0,64	308 NR	308-ZNR	308-2ZNR	SP 90
45	85	19	39,6	32,5	1,37	14 000	9 000	0,44	209 NR	209-ZNR	209-2ZNR	SP 85
	100	25	59,4	46,5	1,96	13 000	8 000	0,88	309 NR	309-ZNR	309-2ZNR	SP 100
50	90	20	39,1	34,5	1,46	13 000	8 000	0,50	210 NR	210-ZNR	210-2ZNR	SP 90
	110	27	64,4	52	2,2	11 000	7 000	1,15	310 NR	310-ZNR	310-2ZNR	SP 110
55	100	21	48,4	44	1,86	12 000	7 500	0,66	211 NR	211-ZNR	211-2ZNR	SP 100
	120	29	79,2	67	2,85	10 000	6 700	1,50	311 NR	311-ZNR	311-2ZNR	SP 120
60	110	22	56,1	50	2,12	11 000	6 700	0,85	212 NR	212-ZNR	212-2ZNR	SP 110
	130	31	91,3	78	3,35	9 500	6 000	1,85	312 NR	312-ZNR	312-2ZNR	SP 130
65	120	23	60,5	58,5	2,5	10 000	6 000	1,05	213 NR	213-ZNR	213-2ZNR	SP 120
	140	33	102	90	3,75	9 000	5 600	2,30	313 NR	313-ZNR	313-2ZNR	SP 140
70	125	24	66	65,5	2,75	9 500	6 000	1,15	214 NR	214-ZNR	214-2ZNR	SP 125
	150	35	114	102	4,15	8 000	5 000	2,75	314 NR	314-ZNR	314-2ZNR	SP 150
75	130	25	72,1	72	3	9 000	5 600	1,25	215 NR	215-ZNR	215-2ZNR	SP 130
80	140	26	88	85	3,45	8 500	5 300	1,55	216 NR	216-ZNR	216-2ZNR	SP 140
85	150	28	96,8	100	3,9	7 500	4 800	1,95	217 NR	–	–	SP 150
90	160	30	112	114	4,3	7 000	4 500	2,35	218 NR	–	–	SP 160
95	170	32	121	122	4,5	6 700	4 300	2,70	219 NR	–	–	SP 170

¹⁾For 2Z design, limiting speeds are about 80 % of the quoted value

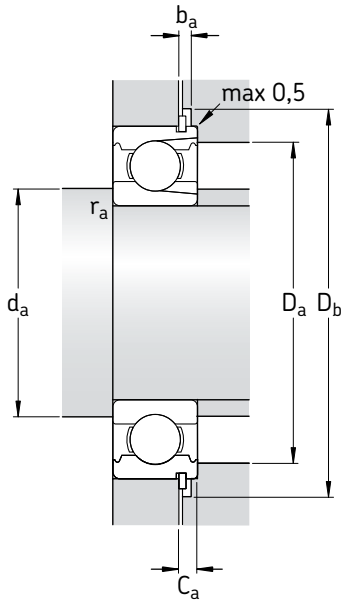

Dimensions

Abutment and fillet dimensions

d	d ₁	D ₂	D ₃	D ₄	f	b	C	r ₀ max	r _{1,2} min	d _a min	D _a max	D _b min	b _a min	C _a max	r _a max
mm										mm					
25	32,8	52,7	59,61	67,7	1,7	1,9	3,28	0,6	1,1	31,5	55,5	69	2,2	4,98	1
30	36,2 40,1	54,1 61,9	59,61 68,81	67,7 78,6	1,7 1,7	1,9 1,9	3,28 3,28	0,6 0,6	1 1,1	35 36,5	57 65,5	69 80	2,2 2,2	4,98 4,98	1 1
35	41,7 43,7	62,7 69,2	68,81 76,81	78,6 86,6	1,7 1,7	1,9 1,9	3,28 3,28	0,6 0,6	1,1 1,5	41,5 43	65,5 72	80 88	2,2 2,2	4,98 4,98	1 1,5
40	48,9 50,5	69,8 77,7	76,81 86,79	86,6 96,5	1,7 2,46	1,9 2,7	3,28 3,28	0,6 0,6	1,1 1,5	46,5 48	73,5 82	88 98	2,2 3	4,98 5,74	1 1,5
45	52,5 55,9	75,2 86,7	81,81 96,8	91,6 106,5	1,7 2,46	1,9 2,7	3,28 3,28	0,6 0,6	1,1 1,5	51,5 53	78,5 92	93 108	2,2 3	4,98 5,74	1 1,5
50	57,5 62,5	81,7 95,2	86,79 106,81	96,5 116,6	2,46 2,46	2,7 2,7	3,28 3,28	0,6 0,6	1,1 2	56,5 61	83,5 99	98 118	3 3	5,74 5,74	1 2
55	63,1 74	89,4 104	96,8 115,21	106,5 129,7	2,46 2,82	2,7 3,1	3,28 4,06	0,6 0,6	1,5 2	63 64	92 111	108 131	3 3,5	5,74 6,88	1,5 2
60	70,1 80,3	97 113	106,81 125,22	116,6 139,7	2,46 2,82	2,7 3,1	3,28 4,06	0,6 0,6	1,5 2,1	68 71	102 119	118 141	3 3,5	5,74 6,88	1,5 2
65	83,3 86,8	106 122	115,21 135,23	129,7 149,7	2,82 2,82	3,1 3,1	4,06 4,9	0,6 0,6	1,5 2,1	73 76	112 129	131 151	3,5 3,5	6,88 7,72	1,5 2
70	87,1 87,2	111 130	120,22 145,24	134,7 159,7	2,82 2,82	3,1 3,1	4,06 4,9	0,6 0,6	1,5 2,1	78 81	117 139	136 162	3,5 3,5	6,88 7,72	1,5 2
75	92,1	117	125,22	139,7	2,82	3,1	4,06	0,6	1,5	83	122	141	3,5	6,88	1,5
80	88,8	127	135,23	149,7	2,82	3,1	4,9	0,6	2	89	131	151	3,5	7,72	2
85	97	135	145,24	159,7	2,82	3,1	4,9	0,6	2	96	139	162	3,5	7,72	2
90	110	143	155,22	169,7	2,82	3,1	4,9	0,6	2	99	151	172	3,5	7,72	2
95	117	152	163,65	182,9	3,1	3,5	5,69	0,6	2,1	107	158	185	4	8,79	2



Stainless steel deep groove ball bearings

Designs	374
Basic design bearings	374
Sealed bearings.....	374
Bearing data – general	375
Dimensions.....	375
Tolerances.....	375
Internal clearance.....	376
Materials	376
Misalignment.....	376
Cages.....	376
Minimum load	376
Axial load carrying capacity	377
Equivalent dynamic bearing load	377
Equivalent static bearing load.....	377
Supplementary designations	377
Design of bearing arrangements	377
Product tables	378
Stainless steel deep groove ball bearings	378
Sealed stainless steel deep groove ball bearings	382

Designs

SKF stainless steel deep groove ball bearings are resistant to corrosion from moisture and several other media. These single row deep groove ball bearings have the same deep raceway grooves and close conformity between raceways and balls as standard deep groove ball bearings made of carbon chromium (rolling bearing) steel. They are without filling slots and can carry axial loads acting in both directions in addition to radial loads, even at high speeds. SKF stainless steel deep groove ball bearings have the same running properties as conventional steel deep groove ball bearings, but have a lower load carrying capacity.

The bearings are available in open and sealed designs for shaft diameters from 1 to 50 mm. Flanged bearings according to ISO 8443-1999 are not presented in this catalogue. They can be found in the “SKF Interactive Engineering Catalogue” on CD-ROM or online at www.skf.com.

SKF stainless steel bearings are identified by the designation prefix W, e.g. W 626-2Z.

Basic design bearings

Basic design bearings are open, i.e. unsealed. Open bearings that are also available with shields or seals may have seal recesses in the outer ring for manufacturing reasons (→ **fig. 1**).

Sealed bearings

Most SKF stainless steel deep groove ball bearings are available with shields. Some are also available with contact seals. Bearings with shields or contact seals on both sides are lubricated for life and are maintenance-free. They should not be washed or heated to temperatures above 80 °C. Depending on the size, stainless steel deep groove ball bearings are supplied charged with two different standard greases. Characteristics of the greases are listed in **table 1**. The standard grease is not identified in the bearing designation. The grease quantity fills some 25 to 35 % of the free space in the bearing.

Fig. 1

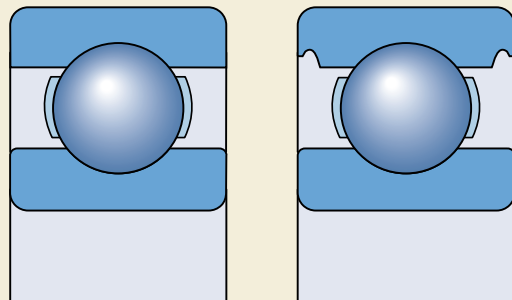

Fig. 2

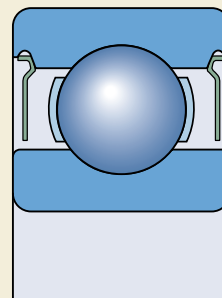
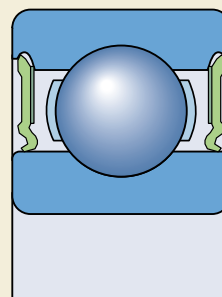

Fig. 3



Because stainless steel deep groove ball bearings are often used in food processing machines, the bearings can be delivered with a special non-toxic grease, designation suffix VT378. This grease

- fulfils the requirements of the “Guidelines of section 21 CFR 178.3570” of the FDA (US Food and Drug Administration) regulations and
- is approved by the USDA (United States Department of Agriculture) for category H1 use (occasional contact with food stuffs).

Please check availability of bearings with non-toxic grease before ordering.

Bearings with shields

Bearing with shields, designation suffix 2Z (→ **fig. 2**), have shields made of stainless steel. The shields form a sealing gap with the land of the bearing inner ring shoulder and enable high temperatures and speeds. Bearings fitted with shields are primarily intended for applications where the inner ring rotates. If the outer ring rotates, there is a risk of grease leaking from the bearing at elevated speeds.

Bearings with contact seals

Bearings with contact seals, designation suffix 2RS1 (→ **fig. 3**), have seals made of an oil and wear resistant acrylonitrile-butadiene rubber (NBR) with a sheet metal reinforcement. The permissible operating temperature range for the seals is -40 to +100 °C and up to +120 °C for

brief periods. Contact seals run with their seal lip on the land of the bearing inner ring shoulder. The seals are fitted with their external edge in the recesses at the outer ring and seal tightly.

Under extreme operating conditions, e.g. at high speeds or high temperatures, grease may leak from bearings fitted with seals. For bearing arrangements where this would be undesirable, special steps must be taken at the design stage. Please consult the SKF engineering application service.

Bearing data – general

Dimensions

The boundary dimensions of stainless steel deep groove ball bearings are in accordance with ISO 15:1998.

Tolerances

SKF stainless steel deep groove ball bearings are manufactured to Normal tolerances. The values for Normal tolerances correspond to ISO 492:2002 and can be found in **table 3** on **page 125**.

Internal clearance

SKF stainless steel deep groove ball bearings are produced as standard with Normal radial internal clearance. The values for the internal clearance are in accordance with ISO 5753:1991 and can be found in **table 3** on **page 297**. The clear-

Table 1

Technical specifications	SKF grease filling for sealed stainless steel deep groove ball bearings		Non-toxic grease
	Standard grease for bearings with d ≤ 9 mm	Lithium soap	
Thickener	Lithium soap	Lithium soap	Aluminum complex soap
Base oil type	Ester oil	Mineral oil	PAO oil
NLGI consistency class	2	2	2
Temperature range, °C ¹⁾	-50 to +140	-30 to +110	-25 to +120
Base oil viscosity, mm ² /s at 40 °C	26	74	150
at 100 °C	5,1	8,5	15,5

¹⁾ For safe operating temperature, → section “Temperature range – the SKF traffic light concept”, starting on **page 232**

Stainless steel deep groove ball bearings

ance limits are valid before mounting under zero measuring load.

Materials

The bearing rings are produced from stainless steel X65Cr14 according to ISO 683-17:2000 or X105CrMo17 according to EN 10088-1:1995, depending on size. The balls are made of stainless steel X105CrMo17 and the shields and cages are made of stainless steel X5CrNi18-10, both according to EN 10088-1:1995.

Misalignment

Single row stainless steel deep groove ball bearings have only limited ability to accommodate misalignment. The permissible angular misalignment between inner and outer rings, which will not produce inadmissibly high additional stresses in the bearing, depends on the radial internal clearance of the bearing in operation, bearing size, the internal design and the forces and moments acting on the bearing. Because of the complex relationship between these factors, no generally applicable specific values can be given. Depending on the various influences of the factors, the permissible angular misalignment lies between 2 and 10 minutes of arc. Any greater misalignment will result in increased noise in operation and decrease bearing service life.

Cages

Depending on the bearing series and size, SKF stainless steel deep groove ball bearings are supplied with one of the following stainless steel cages (→ **fig. 4**) as standard

- a pressed snap-type steel cage, ball centred, no designation suffix (**a**)
- a pressed ribbon-type steel cage, ball centred, no designation suffix (**b**)
- a riveted pressed steel cage, ball centred, no designation suffix (**c**).

For bearings with an injection moulded snap-type cage of glass fibre reinforced polyamide 6,6, please check availability prior to ordering.

Minimum load

In order to provide satisfactory operation, stainless steel deep groove ball bearings, like all ball and roller bearings, must always be subjected to a given minimum load, particularly if they are to operate at high speeds or are subjected to high accelerations or rapid changes in the direction of load. Under such conditions, the inertia forces of the balls and cage, and the friction in the lubricant, can have a detrimental influence on the rolling conditions in the bearing arrangement and may cause damaging sliding movements to occur between the balls and raceways.

The requisite minimum radial load to be applied to stainless steel deep groove ball bearings can be estimated using

$$F_{rm} = k_r \left(\frac{v n}{1\,000} \right)^{2/3} \left(\frac{d_m}{100} \right)^2$$

where

F_{rm} = minimum radial load, kN

k_r = minimum load factor (→ product tables)

v = oil viscosity at operating temperature, mm^2/s

n = rotational speed, r/min

d_m = bearing mean diameter
= 0,5 (d + D), mm

When starting up at low temperatures or when the lubricant is highly viscous, even greater minimum loads may be required. The weight of the components supported by the bearing, together with external forces, generally exceeds

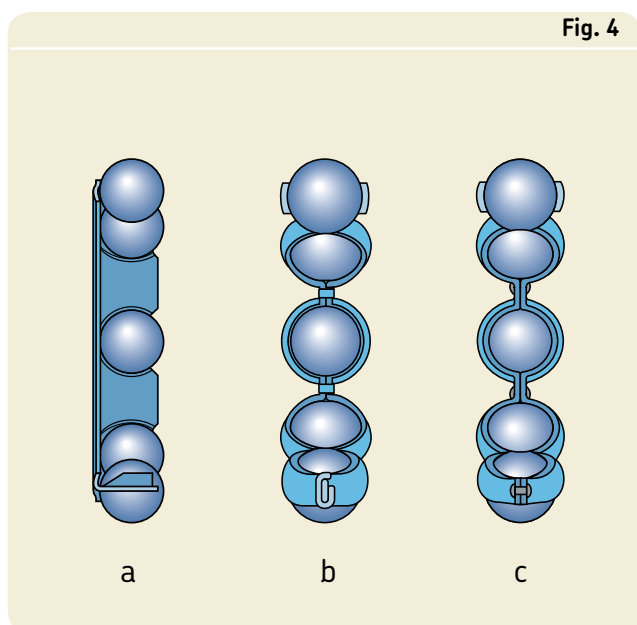

the requisite minimum load. If this is not the case, the stainless steel deep groove ball bearing must be subjected to an additional radial load. For applications where stainless steel deep groove ball bearings are used, an axial preload can be applied by adjusting the inner and outer rings against each other, or by using springs.

Axial load carrying capacity

If the bearings are subjected to a purely axial load, this axial load should generally not exceed the value of $0,25 C_0$. Excessive axial loads can lead to a considerable reduction in bearing service life.

Equivalent dynamic bearing load

$$P = F_r \quad \text{when } F_a/F_r \leq e$$

$$P = 0,56 F_r + Y F_a \quad \text{when } F_a/F_r > e$$

The factors e and Y depend on the relationship $f_0 F_a/C_0$, where f_0 is a calculation factor (\rightarrow product tables), F_a the axial component of the load and C_0 the basic static load rating.

In addition, the factors are influenced by the magnitude of the radial internal clearance. For bearings with Normal internal clearance mounted with the usual fits as listed in **tables 2, 4 and 5** on **pages 169 to 171**, the values for e and Y are listed in **table 2** below.

Table 2

Calculation factors for stainless steel single row deep groove ball bearings

$f_0 F_a/C_0$	e	Y
0,172	0,19	2,30
0,345	0,22	1,99
0,689	0,26	1,71
1,03	0,28	1,55
1,38	0,30	1,45
2,07	0,34	1,31
3,45	0,38	1,15
5,17	0,42	1,04
6,89	0,44	1,00

Intermediate values are obtained by linear interpolation

Equivalent static bearing load

$$P_0 = 0,6 F_r + 0,5 F_a$$

If $P_0 < F_r$, $P_0 = F_r$ should be used.

Supplementary designations

The designation suffixes used to identify certain features of SKF stainless steel deep groove ball bearings are explained in the following.

- R** Flanged outer ring
- VT378** Food grade grease with aluminium thickener of consistency 2 to the NLGI Scale for a temperature range -25 to $+120$ °C (normal fill grade)
- 2RS1** Sheet steel reinforced contact seal of acrylonitrile-butadiene rubber (NBR) on both sides of the bearing
- 2Z** Shield of pressed sheet steel on both sides of the bearing
- 2ZR** Shield of pressed sheet steel on both sides of the bearing and flanged outer ring

Design of bearing arrangements

In most cases the cross section of the bearing rings of a stainless steel deep groove ball bearing is very thin and the side faces correspondingly slim. The transitions from the side faces to the ring bore or outside diameter are also very small. It is therefore necessary to make sure that the adjacent components are appropriate for the bearings and are produced to the required accuracy.

Stainless steel deep groove ball bearings

d 1 – 10 mm

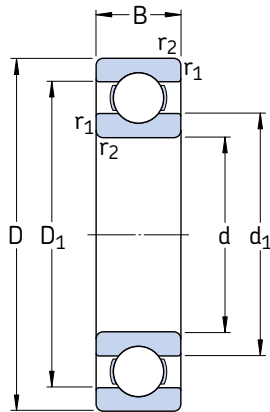

Principal dimensions			Basic load ratings		Fatigue load limit P_u	Speed ratings		Mass	Designation
d	D	B	dynamic C	static C_0		Reference speed	Limiting speed		
mm			kN		kN	r/min		kg	–
1	3	1	0,056	0,017	0,00075	240 000	150 000	0,000036	W 618/1
2	5	1,5	0,133	0,045	0,002	85 000	100 000	0,00015	W 618/2
3	6	3	0,178	0,057	0,0025	170 000	110 000	0,00035	W 637/3
	10	4	0,39	0,129					
4	9	2,5	0,449	0,173	0,0075	140 000	85 000	0,0007	W 618/4
	11	4	0,605	0,224	0,0098	130 000	80 000	0,0019	W 619/4
	12	4	0,676	0,27	0,012	120 000	75 000	0,0024	W 604
	13	5	0,793	0,28	0,012	110 000	67 000	0,0031	W 624
5	11	3	0,54	0,245	0,011	120 000	75 000	0,0012	W 618/5
	13	4	0,741	0,325	0,014	110 000	67 000	0,0023	W 619/5
	16	5	0,923	0,365	0,016	95 000	60 000	0,0050	W 625
6	13	3,5	0,741	0,335	0,015	110 000	67 000	0,0020	W 618/6
	15	5	1,04	0,455	0,02	100 000	63 000	0,0039	W 619/6
	19	6	1,86	0,915	0,04	80 000	50 000	0,0084	W 626
7	17	5	1,24	0,54	0,024	90 000	56 000	0,0049	W 619/7
	19	6	1,86	0,915	0,04	85 000	53 000	0,0075	W 607
	22	7	2,76	1,32	0,057	70 000	45 000	0,013	W 627
8	16	4	1,12	0,55	0,024	90 000	56 000	0,0030	W 618/8
	19	6	1,59	0,71	0,031	80 000	50 000	0,0071	W 619/8
	22	7	2,76	1,32	0,057	75 000	48 000	0,012	W 608
9	17	4	1,19	0,62	0,027	85 000	53 000	0,0034	W 618/9
	20	6	1,74	0,83	0,036	80 000	48 000	0,0076	W 619/9
	24	7	3,12	1,6	0,071	70 000	43 000	0,014	W 609
	26	8	3,9	1,9	0,083	60 000	38 000	0,020	W 629
10	15	3	0,715	0,425	0,018	85 000	56 000	0,0014	W 61700
	19	5	1,14	0,57	0,025	80 000	48 000	0,0055	W 61800
	22	6	1,74	0,815	0,036	75 000	45 000	0,010	W 61900
	26	8	3,9	1,9	0,083	67 000	40 000	0,019	W 6000
	30	9	4,23	2,28	0,1	56 000	34 000	0,032	W 6200
	35	11	6,76	3,25	0,143	50 000	32 000	0,053	W 6300

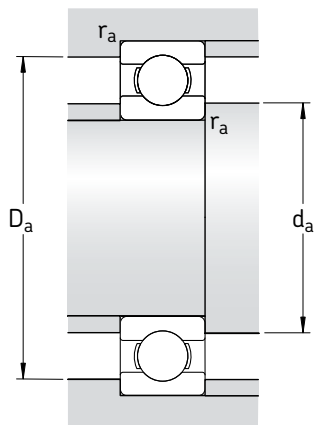

Dimensions				Abutment and fillet dimensions			Calculation factors	
d	d_1	D_1	$r_{1,2}$ min	d_a min	D_a max	r_a max	k_r	f_0
mm				mm			-	
1	1,6	2,4	0,05	1,4	2,6	0,05	0,015	10
2	2,7	3,9	0,08	2,5	4,5	0,08	0,015	11
3	4,2	4,9	0,08	3,5	5,5	0,08	0,020	11
	4,8	7,1	0,15	4,4	8,6	0,1	0,025	8,2
4	5,2	7,5	0,1	4,6	8,4	0,1	0,015	10
	6,2	9	0,15	4,8	10,2	0,1	0,020	8,1
	6,2	9	0,2	5,4	10,6	0,2	0,025	8,3
	7	10,5	0,2	5,8	11,2	0,2	0,025	7,7
5	6,8	9,2	0,15	5,8	10,2	0,1	0,015	11
	7,5	10,5	0,2	6,4	11,6	0,2	0,020	8,8
	8,5	12,5	0,3	7,4	13,6	0,3	0,025	8
6	8	11	0,15	6,8	11,2	0,1	0,015	11
	8,2	11,7	0,2	7,4	13,6	0,2	0,020	8,4
	10,1	15	0,3	8,4	16,6	0,3	0,025	12
7	10,4	13,6	0,3	9	15	0,3	0,020	8,9
	10,1	15	0,3	9	17	0,3	0,025	12
	12,1	18	0,3	9,4	19,6	0,3	0,025	12
8	10,5	13,5	0,2	9,4	14,6	0,2	0,015	11
	10,5	15,5	0,3	10	17	0,3	0,020	8,8
	12,1	18	0,3	10	20	0,3	0,025	12
9	11,5	14,5	0,2	10,4	15,6	0,2	0,015	11
	11,6	16,2	0,3	11	18	0,3	0,020	11
	13,8	19,5	0,3	11	22	0,3	0,025	13
	14,5	21,3	0,3	11,4	23,6	0,3	0,025	12
10	11,2	13,6	0,15	10,8	14,2	0,1	0,015	16
	12,7	16,3	0,3	12	17	0,3	0,015	9,4
	13,9	18,2	0,3	12	20	0,3	0,020	9,3
	14,2	21	0,3	12	24	0,3	0,025	12
	17,6	23,8	0,6	14,2	25,8	0,6	0,025	13
	17,7	27,4	0,6	14,2	30,8	0,6	0,030	11

Stainless steel deep groove ball bearings

d 12 – 50 mm

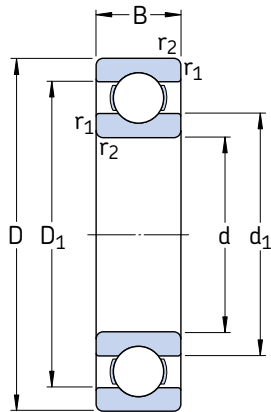

Principal dimensions			Basic load ratings		Fatigue load limit P_u	Speed ratings		Mass	Designation
d	D	B	dynamic C	static C_0		Reference speed	Limiting speed		
mm			kN		kN	r/min	kg	–	
12	21	5	1,21	0,64	0,028	70 000	43 000	0,0063	W 61801
	24	6	1,9	0,95	0,043	67 000	40 000	0,011	W 61901
	28	8	4,23	2,28	0,1	60 000	38 000	0,022	W 6001
	32	10	5,85	3	0,132	50 000	32 000	0,037	W 6201
	37	12	8,19	4,05	0,176	45 000	28 000	0,060	W 6301
15	24	5	1,3	0,78	0,034	60 000	38 000	0,0074	W 61802
	28	7	3,64	2,16	0,095	56 000	34 000	0,016	W 61902
	32	9	4,68	2,75	0,12	50 000	32 000	0,030	W 6002
	35	11	6,5	3,65	0,16	43 000	28 000	0,045	W 6202
	42	13	9,56	5,2	0,228	38 000	24 000	0,085	W 6302
17	30	7	3,9	2,45	0,108	56 000	28 000	0,018	W 61903
	35	10	5,07	3,15	0,137	45 000	28 000	0,039	W 6003
	40	12	8,06	4,65	0,2	38 000	24 000	0,065	W 6203
	47	14	11,4	6,3	0,275	34 000	22 000	0,12	W 6303
20	32	7	3,38	2,24	0,104	45 000	28 000	0,018	W 61804
	42	12	7,93	4,9	0,212	38 000	24 000	0,069	W 6004
	47	14	10,8	6,4	0,28	32 000	20 000	0,11	W 6204
	52	15	13,5	7,65	0,335	30 000	19 000	0,14	W 6304
25	47	12	8,52	5,7	0,25	32 000	20 000	0,08	W 6005
	52	15	11,9	7,65	0,335	28 000	18 000	0,13	W 6205
	62	17	17,2	10,8	0,475	24 000	16 000	0,23	W 6305
30	55	13	11,1	8	0,355	28 000	17 000	0,12	W 6006
	62	16	16,3	10,8	0,475	24 000	15 000	0,2	W 6206
	72	19	22,5	14,6	0,64	20 000	13 000	0,35	W 6306
35	62	14	13,5	10	0,44	24 000	15 000	0,16	W 6007
	72	17	21,6	14,6	0,655	20 000	13 000	0,29	W 6207
40	68	15	14	10,8	0,49	22 000	14 000	0,19	W 6008
	80	18	24,7	17,3	0,75	18 000	11 000	0,37	W 6208
45	75	16	17,8	14,6	0,64	20 000	12 000	0,25	W 6009
	85	19	27,6	19,6	0,865	17 000	11 000	0,41	W 6209
50	80	16	18,2	16	0,71	18 000	11 000	0,26	W 6010
	90	20	29,6	22,4	0,98	15 000	10 000	0,46	W 6210

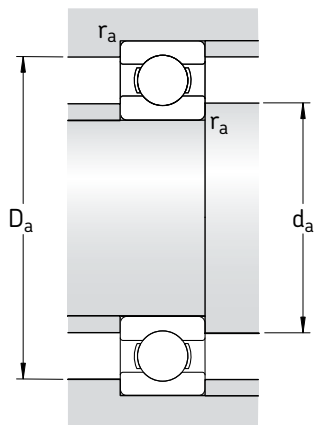

Dimensions			Abutment and fillet dimensions				Calculation factors		
d	d_1	D_1	$r_{1,2}$ min	d_a min	D_a max	r_a max	k_r	f_0	
mm			mm				-		
12	14,8	18,3	0,3	14	19	0,3	0,015	9,7	
	16	20,3	0,3	14	22	0,3	0,020	9,7	
	17,2	24,1	0,3	14	26	0,3	0,025	13	
	18,5	26,2	0,6	16,2	27,8	0,6	0,025	12	
	19,3	29,9	1	17,6	31,4	1	0,030	11	
15	17,8	21,3	0,3	17	22	0,3	0,015	10	
	18,8	24,2	0,3	17	26	0,3	0,020	14	
	20,2	27	0,3	17	30	0,3	0,025	14	
	21,7	29,5	0,6	19,2	30,8	0,6	0,025	13	
	24,5	34,9	1	20,8	36,2	1	0,030	12	
17	21	26,8	0,3	19	28	0,3	0,020	15	
	23,5	30,1	0,3	19	33	0,3	0,025	14	
	24,9	33,6	0,6	21,2	35,8	0,6	0,025	13	
	27,5	38,9	1	22,8	41,2	1	0,030	12	
	20	23,2	28,2	0,3	22	30	0,3	0,015	15
27,6		35,7	0,6	23,2	38,8	0,6	0,025	14	
29,5		39,5	1	25,2	41,8	1	0,025	13	
30		41,7	1,1	27	45	1	0,030	12	
25		31,7	40,2	0,6	28,2	43,8	0,6	0,025	15
	34	44,2	1	30,6	46,4	1	0,025	14	
	38,1	51	1,1	32	55	1	0,030	13	
	30	38	47,3	1	34,6	50,4	1	0,025	15
		40,7	52,8	1	35,6	56,4	1	0,025	14
44,9		59,3	1,1	37	65	1	0,030	13	
35	44	54,3	1	39,6	57,4	1	0,025	15	
	47,6	61,6	1,1	42	65	1	0,025	14	
40	49,2	59,5	1	44,6	63,4	1	0,025	15	
	52,9	67,2	1,1	47	73	1	0,025	14	
45	54,5	65,8	1	49,6	70,4	1	0,025	15	
	56,6	71,8	1,1	52	78	1	0,025	14	
50	60	71	1	54,6	75,4	1	0,025	15	
	63,5	78,7	1,1	57	83	1	0,025	14	

Sealed stainless steel deep groove ball bearings

d 1,5 – 7 mm

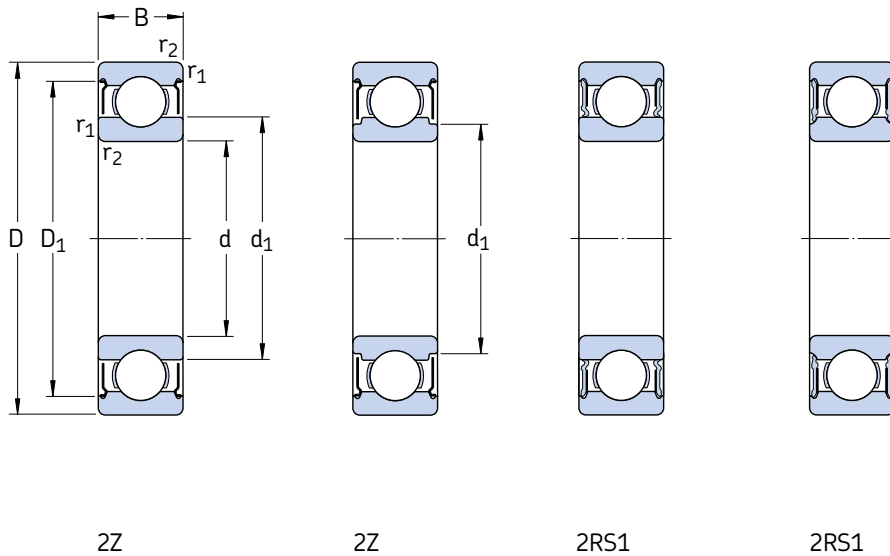

Principal dimensions			Basic load ratings		Fatigue load limit P_u	Speed ratings		Mass	Designation
d	D	B	dynamic C	static C_0		Reference speed	Limiting speed		
mm			kN		kN	r/min		kg	–
1,5	4	2	0,114	0,034	0,0015	220 000	110 000	0,00014	W 638/1.5-2Z
		2	0,114	0,034					
2	5	2,3	0,156	0,048	0,002	190 000	95 000	0,00018	W 638/2-2Z
		3	0,238	0,075					
3	6	3	0,176	0,057	0,0025	170 000	85 000	0,00035	W 637/3-2Z
		3	0,216	0,085					
	8	3	0,39	0,129	0,0056	150 000	75 000	0,00067	W 619/3-2Z
		4	0,39	0,129					
	10	4	0,39	0,129	0,0056	130 000	63 000	0,0015	W 623-2Z
4	9	3,5	0,449	0,173	0,0075	140 000	70 000	0,0010	W 628/4-2Z
		4	0,449	0,173					
	11	4	0,605	0,224	0,0098	130 000	63 000	0,0017	W 619/4-2Z
		4	0,676	0,27					
	13	5	0,793	0,28	0,012	110 000	53 000	0,0031	W 624-2Z
	13	5	0,793	0,28	0,012	–	32 000	0,0031	W 624-2RS1
5	8	2,5	0,14	0,057	0,0025	140 000	70 000	0,00034	W 627/5-2Z
		4	0,54	0,245					
	11	5	0,54	0,245	0,011	120 000	60 000	0,0019	W 638/5-2Z
		4	0,741	0,325					
	16	5	0,923	0,365	0,016	95 000	48 000	0,0050	W 625-2Z
16	5	0,923	0,365	0,016	–	28 000	0,0050	W 625-2RS1	
19	6	1,86	0,915	0,04	80 000	40 000	0,0090	W 635-2Z	
6	10	3	0,319	0,137	0,0061	120 000	60 000	0,0007	W 627/6-2Z
		5	0,741	0,335					
	15	5	1,04	0,455	0,02	100 000	50 000	0,0037	W 619/6-2Z
		6	1,86	0,915					
	19	6	1,86	0,915	0,04	–	24 000	0,0087	W 626-2RS1
7	11	3	0,291	0,127	0,0056	110 000	56 000	0,0007	W 627/7-2Z
		5	0,806	0,39					
	17	5	1,24	0,54	0,024	90 000	45 000	0,0050	W 619/7-2Z
		6	1,86	0,915					
	19	6	1,86	0,915	0,04	–	24 000	0,0082	W 607-2RS1
22	7	2,76	1,32	0,057	70 000	36 000	0,013	W 627-2Z	

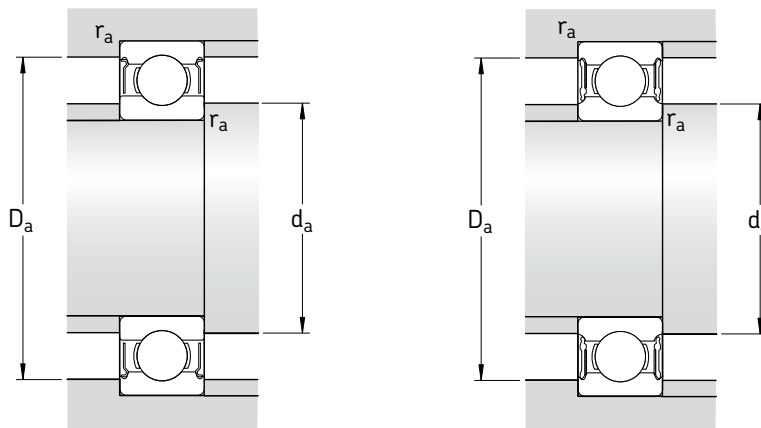

Dimensions				Abutment and fillet dimensions			Calculation factors	
d	d ₁ ~	D ₁ ~	r _{1,2} min	d _a min	D _a max	r _a max	k _r	f ₀
mm				mm			-	
1,5	2,1	3,5	0,05	1,9	3,6	0,05	0,015	9,5
2	2,7	4,4	0,08	2,5	4,5	0,08	0,015	11
	3	5,4	0,15	2,8	5,2	0,1	0,015	10
3	4,2	5,4	0,08	3,5	5,6	0,08	0,020	11
	3,9	6,4	0,1	3,6	6,4	0,1	0,015	11
	5	7,4	0,15	3,8	7,2	0,1	0,020	9,5
	4,4	7,3	0,15	3,8	7,2	0,1	0,020	9,5
	4,4	8	0,15	4,4	8,6	0,1	0,025	8,2
4	5,2	8,1	0,1	4,6	8,4	0,1	0,015	10
	5,2	8,1	0,1	4,6	8,4	0,1	0,015	10
	5,6	9,9	0,15	4,8	10,2	0,1	0,020	8,1
	5,6	9,9	0,2	5,4	10,6	0,2	0,025	8,3
	6	11,4	0,2	5,8	11,2	0,2	0,025	7,7
	6	11,4	0,2	5,8	11,2	0,2	0,025	7,7
5	5,8	7,4	0,08	5,5	7,5	0,08	0,015	10
	6,8	9,9	0,15	5,8	10,2	0,1	0,015	11
	6,2	9,9	0,15	5,8	10,2	0,1	0,015	11
	6,6	11,2	0,2	6,4	11,6	0,2	0,020	8,8
	7,5	13,8	0,3	7,4	13,6	0,3	0,025	8
	7,5	13,8	0,3	7,4	13,6	0,3	0,025	8
	8,5	16,5	0,3	7,4	16,6	0,3	0,030	12
6	7	9,3	0,1	6,6	9,4	0,1	0,015	10
	7,4	11,7	0,15	6,8	11,2	0,1	0,015	11
	7,5	13	0,2	7,4	13,6	0,2	0,020	8,4
	8,5	16,5	0,3	8,4	16,6	0,3	0,025	12
	8,5	16,5	0,3	8,4	16,6	0,3	0,025	12
7	8	10,3	0,1	7,6	10,4	0,1	0,015	10
	8,5	12,7	0,15	7,8	13,2	0,1	0,015	11
	9,3	14,3	0,3	9	15	0,3	0,020	8,9
	9	16,5	0,3	9	17	0,3	0,025	12
	9	16,5	0,3	9	17	0,3	0,025	12
	10,5	19	0,3	9,4	19,6	0,3	0,025	12

Sealed stainless steel deep groove ball bearings

d 8 – 12 mm

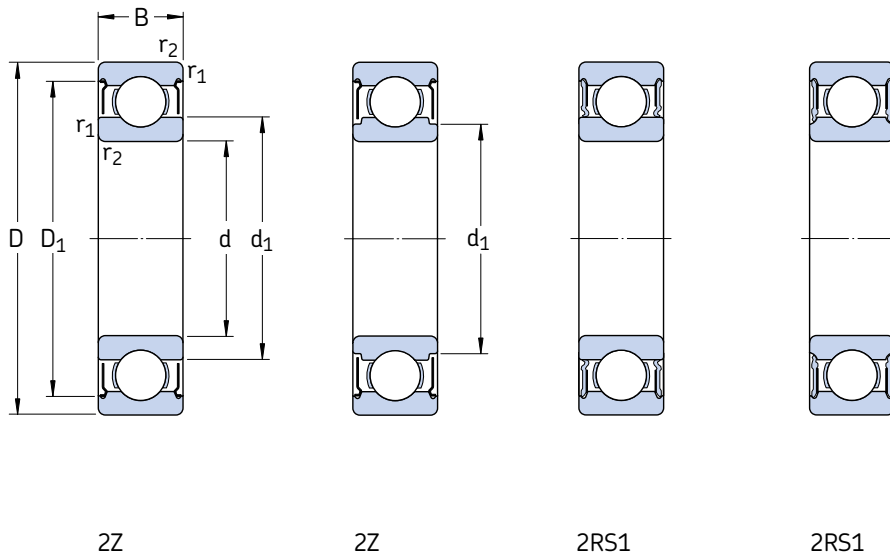

Principal dimensions			Basic load ratings		Fatigue load limit P_u	Speed ratings		Mass	Designation
d	D	B	C	C_0		Reference speed	Limiting speed		
mm			kN		kN	r/min		kg	–
8	16	5	1,12	0,55	0,024	90 000	45 000	0,0040	W 628/8-2Z
	16	6	1,12	0,55	0,024	90 000	45 000	0,0043	W 638/8-2Z
	19	6	1,59	0,71	0,031	80 000	40 000	0,0076	W 619/8-2Z
	19	6	1,46	0,6	1,6	–	24 000	0,0071	W 619/8-2RS1
22	7	2,76	1,32	0,057	75 000	38 000	0,013	W 608-2Z	
	7	2,76	1,32	0,057	–	22 000	0,013	W 608-2RS1	
9	17	5	1,19	0,62	0,027	85 000	43 000	0,0044	W 628/9-2Z
	20	6	1,74	0,83	0,036	80 000	38 000	0,0085	W 619/9-2Z
24	7	3,12	1,6	0,071	70 000	34 000	0,016	W 609-2Z	
	8	3,9	1,9	0,083	60 000	30 000	0,022	W 629-2Z	
10	19	5	1,14	0,57	0,025	80 000	38 000	0,0056	W 61800-2Z
	19	7	1,14	0,57	0,025	80 000	38 000	0,0074	W 63800-2Z
	22	6	1,74	0,815	0,036	75 000	36 000	0,010	W 61900-2Z
	26	8	3,9	1,9	0,083	67 000	34 000	0,019	W 6000-2Z
26	8	3,9	1,9	0,083	–	19 000	0,019	W 6000-2RS1	
30	9	4,23	2,28	0,1	56 000	28 000	0,032	W 6200-2Z	
	9	4,23	2,28	0,1	–	17 000	0,032	W 6200-2RS1	
35	11	6,76	3,25	0,143	50 000	26 000	0,053	W 6300-2Z	
	11	6,76	3,25	0,143	–	15 000	0,053	W 6300-2RS1	
12	21	5	1,21	0,64	0,028	70 000	36 000	0,0065	W 61801-2Z
	24	6	1,9	0,95	0,043	67 000	32 000	0,012	W 61901-2Z
28	8	4,23	2,28	0,1	60 000	30 000	0,022	W 6001-2Z	
	8	4,23	2,28	0,1	–	17 000	0,022	W 6001-2RS1	
32	10	5,85	3	0,132	50 000	26 000	0,037	W 6201-2Z	
	10	5,85	3	0,132	–	15 000	0,037	W 6201-2RS1	
37	12	8,19	4,05	0,176	45 000	22 000	0,06	W 6301-2Z	
	12	8,19	4,05	0,176	–	14 000	0,06	W 6301-2RS1	

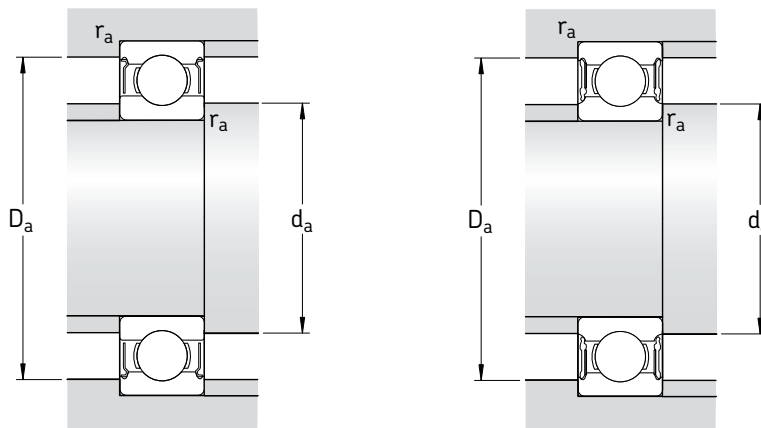

Dimensions			Abutment and fillet dimensions				Calculation factors	
d	d_1	D_1	$r_{1,2}$ min	d_a min	D_a max	r_a max	k_r	f_0
mm				mm		-		
8	9,6	14,2	0,2	9,4	14,6	0,2	0,015	11
	9,6	14,2	0,2	9,4	14,6	0,2	0,015	11
	9,8	16,7	0,3	9,8	17	0,3	0,020	8,8
	9,8	16,7	0,3	9,8	17	0,3	0,020	8,8
9	10,5	19	0,3	10	20	0,3	0,025	12
	10,5	19	0,3	10	20	0,3	0,025	12
	10,7	15,2	0,2	10,4	15,6	0,2	0,015	11
	11,6	17,5	0,3	11	18	0,3	0,020	11
10	12,1	20,5	0,3	11	22	0,3	0,025	13
	13,9	22,4	0,3	11,4	23,6	0,3	0,025	12
	11,8	17,2	0,3	11,8	17	0,3	0,015	9,4
	11,8	17,2	0,3	11,8	17	0,3	0,015	9,4
12	13,2	19,4	0,3	12	20	0,3	0,020	9,3
	12,9	22,4	0,3	12	24	0,3	0,025	12
	12,9	22,4	0,3	12	24	0,3	0,025	12
	15,3	25,3	0,6	14,2	25,8	0,6	0,025	13
	15,3	25,3	0,6	14,2	25,8	0,6	0,025	13
	17,7	29,3	0,6	14,2	30,8	0,6	0,030	11
12	17,7	29,3	0,6	14,2	30,8	0,6	0,030	11
	13,8	19,2	0,3	13,8	19	0,3	0,015	9,7
	15,4	21,4	0,3	14	22	0,3	0,020	9,7
	17,2	25,5	0,3	14	26	0,3	0,025	13
	17,2	25,5	0,3	14	26	0,3	0,025	13
	18,5	28	0,6	16,2	27,8	0,6	0,025	12
	18,5	28	0,6	16,2	27,8	0,6	0,025	12
	19,3	31,9	1	17,6	31,4	1	0,030	11
19,3	31,9	1	17,6	31,4	1	0,030	11	

Sealed stainless steel deep groove ball bearings
d 15 – 20 mm

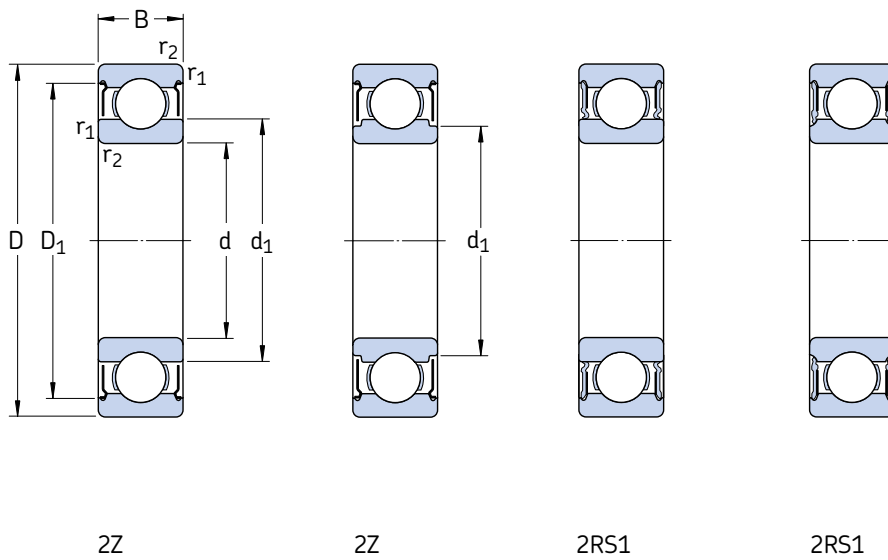

Principal dimensions			Basic load ratings		Fatigue load limit P_u	Speed ratings		Mass	Designation
d	D	B	dynamic C	static C_0		Reference speed	Limiting speed		
mm			kN		kN	r/min		kg	–
15	24	5	1,3	0,78	0,034	60 000	30 000	0,0076	W 61802-2Z
	28	7	3,64	2,16	0,095	56 000	28 000	0,019	W 61902-2Z
	28	7	3,64	2,16	0,095	–	16 000	0,019	W 61902-2RS1
	32	9	4,68	2,75	0,12	50 000	26 000	0,030	W 6002-2Z
	32	9	4,68	2,75	0,12	–	14 000	0,030	W 6002-2RS1
	35	11	6,5	3,65	0,16	43 000	22 000	0,045	W 6202-2Z
	35	11	6,5	3,65	0,16	–	13 000	0,045	W 6202-2RS1
	42	13	9,56	5,2	0,228	38 000	19 000	0,082	W 6302-2Z
	42	13	9,56	5,2	0,228	–	12 000	0,082	W 6302-2RS1
17	26	5	1,4	0,9	0,039	56 000	34 000	0,0082	W 61803-2Z
	30	7	3,9	2,45	0,108	50 000	32 000	0,019	W 61903-2Z
	30	7	3,9	2,45	0,108	–	14 000	0,019	W 61903-2RS1
	35	10	5,07	3,15	0,137	45 000	22 000	0,039	W 6003-2Z
	35	10	5,07	3,15	0,137	–	13 000	0,039	W 6003-2RS1
	40	12	8,06	4,65	0,2	38 000	19 000	0,065	W 6203-2Z
	40	12	8,06	4,65	0,2	–	12 000	0,065	W 6203-2RS1
	47	14	11,4	6,3	0,275	34 000	17 000	0,12	W 6303-2Z
	47	14	11,4	6,3	0,275	–	11 000	0,12	W 6303-2RS1
20	32	7	3,38	2,24	0,104	–	13 000	0,018	W 61804-2RS1
	37	9	5,4	3,55	0,156	–	12 000	0,04	W 61904-2RS1
	42	12	7,93	4,9	0,212	38 000	19 000	0,069	W 6004-2Z
	42	12	7,93	4,9	0,212	–	11 000	0,069	W 6004-2RS1
	47	14	10,8	6,4	0,28	32 000	17 000	0,11	W 6204-2Z
	47	14	10,8	6,4	0,28	–	10 000	0,11	W 6204-2RS1
	52	15	13,5	7,65	0,335	30 000	15 000	0,14	W 6304-2Z
	52	15	13,5	7,65	0,335	–	9 500	0,14	W 6304-2RS1

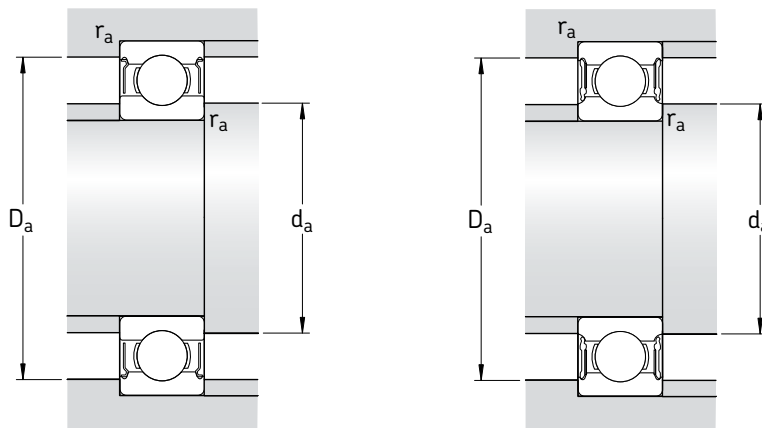

Dimensions			Abutment and fillet dimensions				Calculation factors	
d	d_1 ~	D_1 ~	$r_{1,2}$ min	d_a min	D_a max	r_a max	k_r	f_0
mm				mm			-	
15	16,8	22,2	0,3	16,8	22	0,3	0,015	10
	18,8	25,3	0,3	17	26	0,3	0,020	14
	18,8	25,3	0,3	17	26	0,3	0,020	14
	20,2	28,7	0,3	17	30	0,3	0,025	14
	20,2	28,7	0,3	17	30	0,3	0,025	14
	21,7	31,4	0,6	19,2	30,8	0,6	0,025	13
	21,7	31,4	0,6	19,2	30,8	0,6	0,025	13
	24,5	36,8	1	20,8	36,2	1	0,030	12
	24,5	36,8	1	20,8	36,2	1	0,030	12
	17	18,8	24,3	0,3	18,8	24	0,3	0,015
21		27,8	0,3	19	28	0,3	0,020	15
21		27,8	0,3	19	28	0,3	0,020	15
23,5		31,9	0,3	19	33	0,3	0,025	14
23,5		31,9	0,3	19	33	0,3	0,025	14
24,9		35,8	0,6	21,2	35,8	0,6	0,025	13
24,9		35,8	0,6	21,2	35,8	0,6	0,025	13
27,5		41,1	1	22,8	41,2	1	0,030	12
27,5		41,1	1	22,8	41,2	1	0,030	12
20		22,6	29,5	0,3	22	30	0,3	0,015
	23,6	33,5	0,3	22	35	0,3	0,020	15
	27,6	38,7	0,6	23,2	38,8	0,6	0,025	14
	27,6	38,7	0,6	23,2	38,8	0,6	0,025	14
	29,5	40,9	1	25,2	41,8	1	0,025	13
	29,5	40,9	1	25,2	41,8	1	0,025	13
	30	45,4	1,1	27	45	1	0,030	12
	30	45,4	1,1	27	45	1	0,030	12

Sealed stainless steel deep groove ball bearings
d 25 – 50 mm

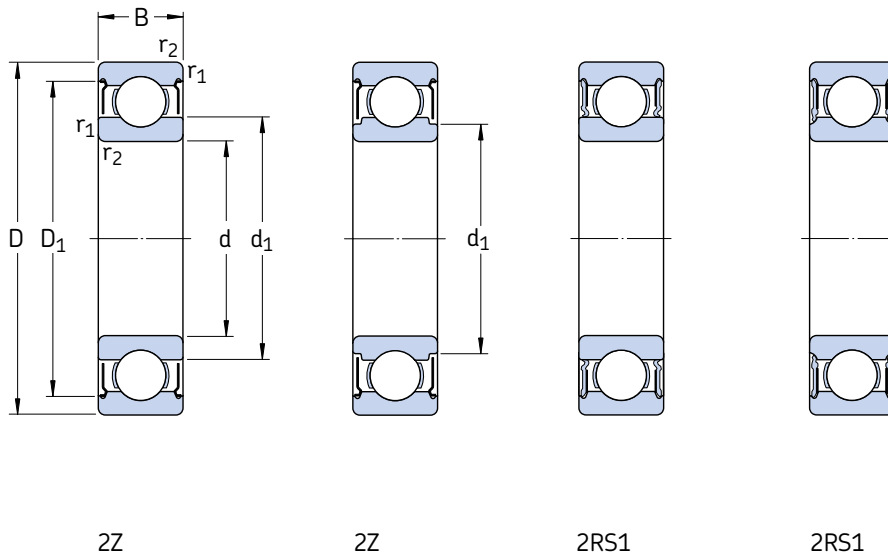

Principal dimensions			Basic load ratings		Fatigue load limit P_u	Speed ratings		Mass	Designation
d	D	B	C	C_0		Reference speed	Limiting speed		
mm			kN		kN	r/min		kg	–
25	42	9	5,92	4,15	0,193	–	10 000	0,047	W 61905-2RS1
	47	12	8,52	5,7	0,25	32 000	16 000	0,08	W 6005-2Z
25	47	12	8,52	5,7	0,25	–	9 500	0,08	W 6005-2RS1
	52	15	11,9	7,65	0,335	28 000	14 000	0,13	W 6205-2Z
	52	15	11,9	7,65	0,335	–	8 500	0,13	W 6205-2RS1
	62	17	17,2	10,8	0,475	24 000	13 000	0,23	W 6305-2Z
25	62	17	17,2	10,8	0,475	–	7 500	0,23	W 6305-2RS1
	30	55	13	11,1	8	0,355	28 000	14 000	0,12
30	55	13	11,1	8	0,355	–	8 000	0,12	W 6006-2RS1
	62	16	16,3	10,8	0,475	24 000	12 000	0,2	W 6206-2Z
30	62	16	16,3	10,8	0,475	–	7 500	0,2	W 6206-2RS1
	72	19	22,5	14,6	0,64	20 000	11 000	0,35	W 6306-2Z
30	72	19	22,5	14,6	0,64	–	6 300	0,35	W 6306-2RS1
	35	62	14	13,5	10	0,44	24 000	12 000	0,16
35	62	14	13,5	10	0,44	–	7 000	0,16	W 6007-2RS1
	72	17	21,6	14,6	0,655	20 000	10 000	0,29	W 6207-2Z
35	72	17	21,6	14,6	0,655	–	6 300	0,29	W 6207-2RS1
	40	68	15	14	10,8	0,49	22 000	11 000	0,19
40	68	15	14	10,8	0,49	–	6 300	0,19	W 6008-2RS1
	80	18	24,7	17,3	0,75	18 000	9 000	0,37	W 6208-2Z
40	80	18	24,7	17,3	0,75	–	5 600	0,37	W 6208-2RS1
	45	75	16	17,8	14,6	0,64	20 000	10 000	0,25
45	75	16	17,8	14,6	0,64	–	5 600	0,25	W 6009-2RS1
	85	19	27,6	19,6	0,865	17 000	8 500	0,41	W 6209-2Z
45	85	19	27,6	19,6	0,865	–	5 000	0,41	W 6209-2RS1
	50	80	16	18,2	16	0,71	18 000	9 000	0,26
50	80	16	18,2	16	0,71	–	5 000	0,26	W 6010-2RS1
	90	20	29,6	22,4	0,98	15 000	8 000	0,46	W 6210-2Z
50	90	20	29,6	22,4	0,98	–	4 800	0,46	W 6210-2RS1

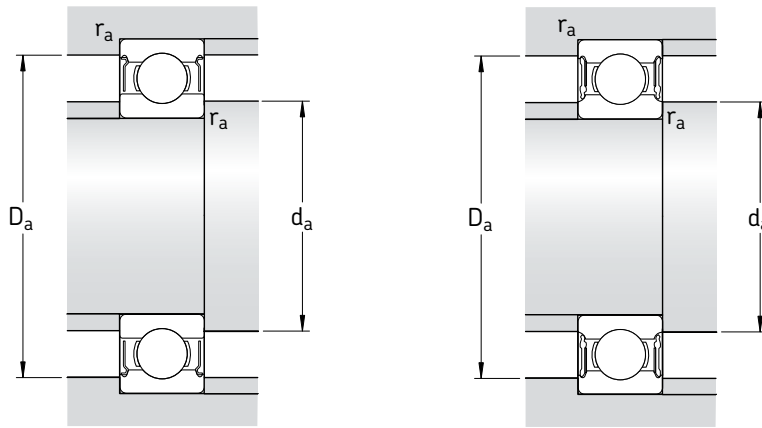

Dimensions				Abutment and fillet dimensions			Calculation factors	
d	d_1	D_1	$r_{1,2}$ min	d_a min	D_a max	r_a max	k_r	f_0
mm				mm			-	
25	30,9	39,5	0,3	27	40	0,3	0,020	15
	31,7	42,7	0,6	28,2	43,8	0,6	0,025	15
30	31,7	42,7	0,6	28,2	43,8	0,6	0,025	15
	34	45,7	1	30,6	46,4	1	0,025	14
	34	45,7	1	30,6	46,4	1	0,025	14
	38,1	53,2	1,1	32	55	1	0,030	13
35	38,1	53,2	1,1	32	55	1	0,030	13
	38	49,9	1	34,6	50,4	1	0,025	15
	38	49,9	1	34,6	50,4	1	0,025	15
	40,7	55,1	1	35,6	56,4	1	0,025	14
	40,7	55,1	1	35,6	56,4	1	0,025	14
	44,9	62,4	1,1	37	65	1	0,030	13
40	44,9	62,4	1,1	37	65	1	0,030	13
	44	57,1	1	39,6	57,4	1	0,025	15
	44	57,1	1	39,6	57,4	1	0,025	15
	47,6	64,9	1,1	42	65	1	0,025	14
45	47,6	64,9	1,1	42	65	1	0,025	14
	49,2	62,5	1	44,6	63,4	1	0,025	15
	49,2	62,5	1	44,6	63,4	1	0,025	15
	52,9	70,8	1,1	47	73	1	0,025	14
50	52,9	70,8	1,1	47	73	1	0,025	14
	54,5	69	1	49,6	70,4	1	0,025	15
	54,5	69	1	49,6	70,4	1	0,025	15
	56,6	74,5	1,1	52	78	1	0,025	14
55	56,6	74,5	1,1	52	78	1	0,025	14
	60	74,6	1	54,6	75,4	1	0,025	15
	60	74,6	1	54,6	75,4	1	0,025	15
	63,5	81,4	1,1	57	83	1	0,025	14
60	63,5	81,4	1,1	57	83	1	0,025	14



Double row deep groove ball bearings

Design	392
Bearing data – general	392
Dimensions.....	392
Tolerances.....	392
Internal clearance.....	392
Misalignment.....	392
Cages.....	392
Minimum load	393
Axial load carrying capacity	393
Equivalent dynamic bearing load	393
Equivalent static bearing load.....	393
Product table	394

Design

SKF double row deep groove ball bearings (→ **fig. 1**) correspond in design to single row deep groove ball bearings. They have deep uninterrupted raceways and high conformity between the balls and raceways. They are able to carry axial loads acting in both directions in addition to radial loads.

Double row deep groove ball bearings are very suitable for bearing arrangements where the load carrying capacity of a single row bearing is inadequate. For the same outside and bore diameters, double row bearings are slightly wider than single row bearings but have considerably higher load carrying capacity than single row bearings in the 62 and 63 series.

Fig. 1

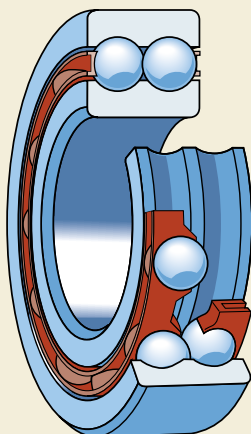
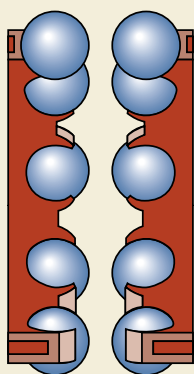

Fig. 2



Bearing data – general

Dimensions

The boundary dimensions of SKF double row deep groove ball bearings are in accordance with ISO 15:1998.

Tolerances

SKF double row deep groove ball bearings are produced to Normal tolerances. The values for tolerances correspond to ISO 492:2002 and can be found in **table 3** on **page 125**.

Internal clearance

SKF double row deep groove ball bearings have Normal radial internal clearance as standard. The clearance limits are as specified in ISO 5753:1991 and can be found in **table 4** on **page 297**.

Misalignment

Misalignment of the inner ring relative to the outer ring of a double row deep groove ball bearing can only be accommodated by force, which leads to increased ball loads and cage forces and a reduction in bearing service life. For this reason, the maximum permissible angular misalignment is two minutes of arc. Any misalignment of the bearing rings will result in increased noise during operation.

Cages

SKF double row deep groove ball bearings are fitted with two injection moulded snap-type cages of glass fibre reinforced polyamide 6,6 (→ **fig. 2**), ball centred, designation suffix TN9.

Note

Double row deep groove ball bearings with polyamide 6,6 cages can be operated at temperatures up to +120 °C. The lubricants generally used for rolling bearings do not have a detrimental effect on cage properties, with the exception of a few synthetic oils and greases with a synthetic oil base, and lubricants containing a high proportion of EP additives when used at high temperatures.

For detailed information about the temperature resistance and the applicability of cages,

please refer to the section “Cage materials”, starting on **page 140**.

Minimum load

In order to obtain satisfactory operation, double row deep groove ball bearings, like all ball and roller bearings, must be subjected to a given minimum load, particularly if they are to operate at high speeds or are subjected to high accelerations or rapid changes in the direction of load. Under such conditions, the inertia forces of the balls and cages, and the friction in the lubricant, can have a detrimental effect on the rolling conditions in the bearing arrangement and may cause damaging sliding movements to occur between the balls and raceways.

The requisite minimum load to be applied to double row deep groove ball bearings can be estimated using

$$F_{rm} = k_r \left(\frac{v n}{1\,000} \right)^{2/3} \left(\frac{d_m}{100} \right)^2$$

where

- F_{rm} = minimum radial load, kN
- k_r = minimum radial load factor
(→ product table)
- v = oil viscosity at operating temperature, mm²/s
- n = rotational speed, r/min
- d_m = bearing mean diameter
= 0,5 (d + D), mm

When starting up at low temperatures or when the lubricant is highly viscous, even greater minimum loads may be required. The weight of the components supported by the bearing, together with external forces, generally exceeds the requisite minimum load. If this is not the case, the double row deep groove ball bearings must be subjected to additional radial load.

Axial load carrying capacity

If double row deep groove ball bearings are subjected to a purely axial load, this axial load should generally not exceed the value of 0,5 C_0 . Excessive axial loads can lead to a substantial reduction in bearing life.

Equivalent dynamic bearing load

$$P = F_r \quad \text{when } F_a/F_r \leq e$$

$$P = 0,56 F_r + Y F_a \quad \text{when } F_a/F_r > e$$

The factors e and Y depend on the relationship $f_0 F_a/C_0$, where f_0 is a calculation factor (→ product table), F_a the axial component of the load and C_0 the basic static load rating.

In addition, the factors are influenced by the magnitude of the radial internal clearance. For bearings with Normal internal clearance mounted with the usual fits as listed in **table 2, 4 and 5** on **pages 169 to 171**, the values for e and Y are listed in **table 1** below.

Equivalent static bearing load

$$P_0 = 0,6 F_r + 0,5 F_a$$

If $P_0 < F_r$, $P_0 = F_r$ should be used.

Table 1

Calculation factors for double row deep groove ball bearings

$f_0 F_a/C_0$	e	Y
0,172	0,19	2,30
0,345	0,22	1,99
0,689	0,26	1,71
1,03	0,28	1,55
1,38	0,30	1,45
2,07	0,34	1,31
3,45	0,38	1,15
5,17	0,42	1,04
6,89	0,44	1,00

Intermediate values are obtained by linear interpolation

Double row deep groove ball bearings

d 10 – 65 mm

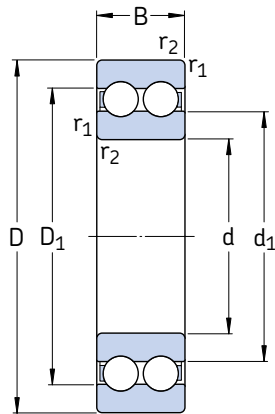

Principal dimensions			Basic load ratings		Fatigue load limit P_u	Speed ratings		Mass	Designation
d	D	B	dynamic C	static C_0		Reference speed	Limiting speed		
mm			kN		kN	r/min		kg	–
10	30	14	9,23	5,2	0,224	40 000	22 000	0,049	4200 ATN9
12	32	14	10,6	6,2	0,26	36 000	20 000	0,053	4201 ATN9
	37	17	13	7,8	0,325	34 000	18 000	0,092	4301 ATN9
15	35	14	11,9	7,5	0,32	32 000	17 000	0,059	4202 ATN9
	42	17	14,8	9,5	0,405	28 000	15 000	0,120	4302 ATN9
17	40	16	14,8	9,5	0,405	28 000	15 000	0,090	4203 ATN9
	47	19	19,5	13,2	0,56	24 000	13 000	0,16	4303 ATN9
20	47	18	17,8	12,5	0,53	24 000	13 000	0,14	4204 ATN9
	52	21	23,4	16	0,68	22 000	12 000	0,21	4304 ATN9
25	52	18	19	14,6	0,62	20 000	11 000	0,16	4205 ATN9
	62	24	31,9	22,4	0,95	18 000	10 000	0,34	4305 ATN9
30	62	20	26	20,8	0,88	17 000	9 500	0,26	4206 ATN9
	72	27	41	30	1,27	16 000	8 500	0,50	4306 ATN9
35	72	23	35,1	28,5	1,2	15 000	8 000	0,40	4207 ATN9
	80	31	50,7	38	1,63	14 000	7 500	0,69	4307 ATN9
40	80	23	37,1	32,5	1,37	13 000	7 000	0,50	4208 ATN9
	90	33	55,9	45	1,9	12 000	6 700	0,95	4308 ATN9
45	85	23	39	36	1,53	12 000	6 700	0,54	4209 ATN9
	100	36	68,9	56	2,4	11 000	6 000	1,25	4309 ATN9
50	90	23	41	40	1,7	11 000	6 000	0,58	4210 ATN9
	110	40	81,9	69,5	2,9	10 000	5 300	1,70	4310 ATN9
55	100	25	44,9	44	1,9	10 000	5 600	0,80	4211 ATN9
	120	43	97,5	83	3,45	9 000	5 000	2,15	4311 ATN9
60	110	28	57,2	55	2,36	9 500	5 300	1,10	4212 ATN9
	130	46	112	98	4,15	8 500	4 500	2,65	4312 ATN9
65	120	31	67,6	67	2,8	8 500	4 800	1,45	4213 ATN9
	140	48	121	106	4,5	8 000	4 300	3,25	4313 ATN9

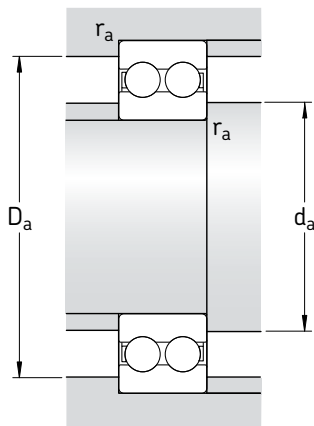

Dimensions				Abutment and fillet dimensions			Calculation factors	
d	d_1 ~	D_1 ~	$r_{1,2}$ min	d_a min	D_a max	r_a max	k_r	f_o
mm				mm			-	
10	16,7	23,3	0,6	14,2	25,8	0,6	0,05	12
12	18,3 20,5	25,7 28,5	0,6 1	16,2 17,6	27,8 31,4	0,6 1	0,05 0,06	12 12
15	21,5 24,5	29 32,5	0,6 1	19,2 20,6	30,8 36,4	0,6 1	0,05 0,06	13 13
17	24,3 28,7	32,7 38,3	0,6 1	21,2 22,6	35,8 41,4	0,6 1	0,05 0,06	13 13
20	29,7 31,8	38,3 42,2	1 1,1	25,6 27	41,4 45	1 1	0,05 0,06	14 13
25	34,2 37,3	42,8 49,7	1 1,1	30,6 32	46,4 55	1 1	0,05 0,06	14 13
30	40,9 43,9	51,1 58,1	1 1,1	35,6 37	56,4 65	1 1	0,05 0,06	14 13
35	47,5 49,5	59,5 65,4	1,1 1,5	42 44	65 71	1 1,5	0,05 0,06	14 13
40	54 56,9	66 73,1	1,1 1,5	47 49	73 81	1 1,5	0,05 0,06	15 14
45	59,5 63,5	71,5 81,5	1,1 1,5	52 54	78 91	1 1,5	0,05 0,06	15 14
50	65,5 70	77,5 90	1,1 2	57 61	83 99	1 2	0,05 0,06	15 14
55	71,2 76,5	83,8 98,5	1,5 2	64 66	91 109	1,5 2	0,05 0,06	16 14
60	75,6 83,1	90,4 107	1,5 2,1	69 72	101 118	1,5 2	0,05 0,06	15 14
65	82,9 89,6	99,1 115	1,5 2,1	74 77	111 128	1,5 2	0,05 0,06	15 14

Double row deep groove ball bearings
d 70 – 100 mm

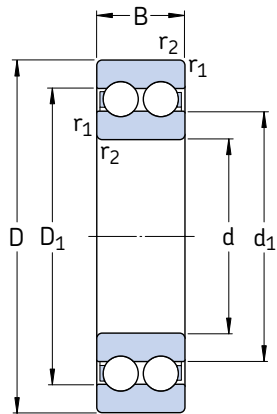

Principal dimensions			Basic load ratings		Fatigue load limit P_u	Speed ratings		Mass	Designation
d	D	B	dynamic C	static C_0		Reference speed	Limiting speed		
mm			kN		kN	r/min		kg	–
70	125	31	70,2	73,5	3,1	8 000	4 300	1,50	4214 ATN9
	150	51	138	125	5	7 000	3 800	3,95	4314 ATN9
75	130	31	72,8	80	3,35	7 500	4 000	1,60	4215 ATN9
	160	55	156	143	5,5	6 700	3 600	4,80	4315 ATN9
80	140	33	80,6	90	3,6	7 000	3 800	2,00	4216 ATN9
85	150	36	93,6	102	4	7 000	3 600	2,55	4217 ATN9
90	160	40	112	122	4,65	6 300	3 400	3,20	4218 ATN9
100	180	46	140	156	5,6	5 600	3 000	4,70	4220 ATN9

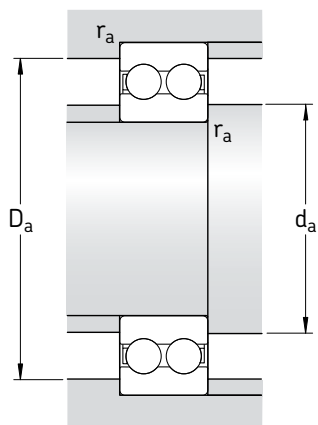

Dimensions				Abutment and fillet dimensions			Calculation factors	
d	d_1 ~	D_1 ~	$r_{1,2}$ min	d_a min	D_a max	r_a max	k_r	f_o
mm				mm			-	
70	89,4	106	1,5	79	116	1,5	0,05	15
	96,7	124	2,1	82	138	2	0,06	14
75	96,9	114	1,5	84	121	1,5	0,05	16
	103	132	2,1	87	148	2	0,06	14
80	102	120	2	91	129	2	0,05	16
85	105	125	2	96	139	2	0,05	15
90	114	136	2	101	149	2	0,05	15
100	130	154	2,1	112	168	2	0,05	15



Single row cam rollers

Designs	400
Cam roller data – general	400
Dimensions.....	400
Tolerances.....	400
Internal clearance.....	400
Cages.....	400
Load carrying ability	400
Axial load carrying capacity	401
Design of associated components	401
Pins	401
Guide flanges	401
Lubrication	401
Product table	402

Designs

Single row cam rollers (→ **fig. 1**) in the narrow 3612(00) R series are based on deep groove ball bearings in the 62 series. They have a crowned runner surface and incorporate sheet steel reinforced acrylonitrile-butadiene rubber (NBR) contact seals on both sides. They are ready-to-mount pre-greased cam rollers and are used for all types of cam drives, conveyor systems etc. Because of their crowned runner surface they can be used in applications where angular misalignment with respect to the track may be expected; and where edge stresses need to be minimized.

In addition to single row cam rollers, the SKF standard range of track runner bearings comprises other cam rollers, support rollers, or cam followers. These are for example

- double row cam rollers, wide series 3057(00) and 3058(00), → **page 463**
- support rollers based on needle roller or cylindrical roller bearings
- cam followers based on needle roller or cylindrical roller bearings.

For further information on support rollers and cam followers, consult the SKF catalogue “Needle roller bearings” or the “SKF Interactive Engineering Catalogue” on CD-ROM or online at www.skf.com.

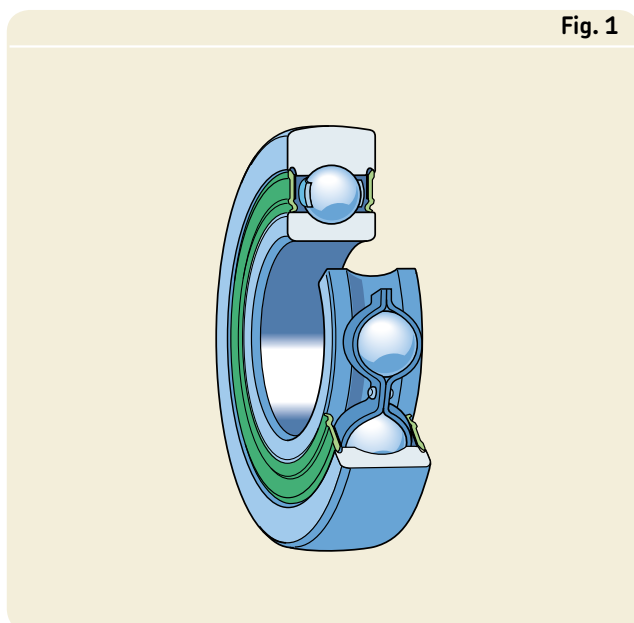

Fig. 1

Cam roller data – general

Dimensions

With the exception of the outside diameter, the boundary dimensions of SKF single row cam rollers are in accordance with ISO 15:1998 for bearings in the O2 Dimension Series.

Tolerances

SKF single row cam rollers are produced to Normal tolerances as standard, except for the tolerance of the crowned runner surface diameter which is twice the Normal tolerance.

The values for tolerances correspond to ISO 492:2002 and can be found in **table 3** on **page 125**.

Internal clearance

SKF single row cam rollers have C3 radial internal clearance as standard. The clearance limits are as specified in ISO 5753:1991 and can be found in **table 4** on **page 297**.

Cages

SKF single row cam rollers are fitted with a riveted pressed steel cage, ball centred, no designation suffix.

Load carrying ability

In contrast to normal ball bearings, where the outer ring is supported over its entire outside diameter surface in the bore of a housing, the outer ring of a cam roller has only a small contact area with the surface against which it runs, e.g. a rail or cam. The actual contact area depends on the applied radial load and the crowning of the runner surface. The deformation of the outer ring caused by this limited contact alters the force distribution in the bearing and thus has an influence on load carrying ability. The basic load ratings provided in the product table take this into account.

The ability to carry dynamic loads depends on the requisite life, but with reference to the deformation and the strength of the outer ring, the value of the maximum dynamic radial load F_r must not be exceeded.

The permissible static load for a cam roller is determined by the smaller of the values of F_{0r} and C_0 . If requirements regarding smooth running are below normal, the static load may exceed C_0 but should never exceed the maximum permissible static radial load F_{0r} .

Axial load carrying capacity

Cam rollers are intended for predominantly radial loads. If an axial load acts on the outer ring, as when the cam roller runs against a guide flange, it will produce a tilting moment and the service life of the cam roller may be reduced as a consequence.

Design of associated components

Pins

With few exceptions, cam rollers operate under conditions of stationary inner ring load. If easy displacement of the inner ring is required under such conditions, the pin or shaft should be machined to tolerance g6. If, for some reason, a tighter fit is required, then the pin or shaft should be machined to tolerance j6.

For applications where cam rollers are subjected to heavier axial loads, SKF recommends supporting the inner ring of the cam roller over its entire side face (→ **fig. 2**). The diameter of the supporting surface should be the same as the face diameter d_1 of the inner ring (→ product table, **page 402**).

Guide flanges

For rails or cams with guide flanges (→ **fig. 2**), the recommended flange height h_a should not exceed

$$h_a = 0,5 (D - D_1)$$

This helps to avoid damage to the seals fitted in the outer ring. The values for the outer ring diameters D and D_1 are listed in the product table.

Lubrication

SKF single row cam rollers are greased for life and cannot be relubricated. They are filled with a grease with lithium thickener of consistency 3 to the NLGI Scale with good rust inhibiting properties and a temperature range of -30 to $+120$ °C. The base oil viscosity is $98 \text{ mm}^2/\text{s}$ at 40 °C and $9,4 \text{ mm}^2/\text{s}$ at 100 °C.

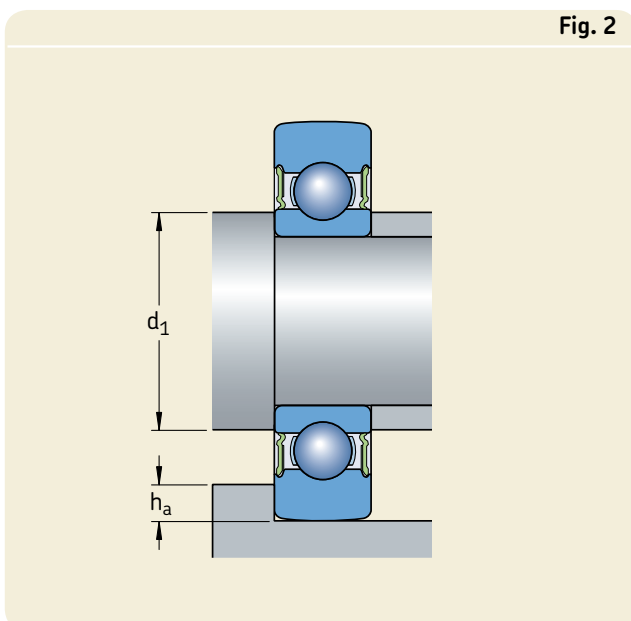

Single row cam rollers
D 32 – 80 mm

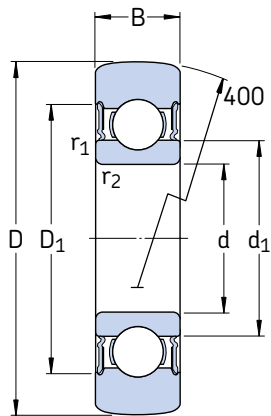

Dimensions						Limiting speed	Mass	Designation
D	B	d	d ₁	D ₁	r _{1,2} min			
mm						r/min	kg	–
32	9	10	14,8	23,4	0,6	12 000	0,041	361200 R
35	10	12	16,1	25,9	0,6	11 000	0,052	361201 R
40	11	15	19,2	29,7	0,6	9 500	0,074	361202 R
47	12	17	21,6	32,9	0,6	8 500	0,11	361203 R
52	14	20	26	38,7	1	7 500	0,16	361204 R
62	15	25	31,4	44,2	1	6 300	0,24	361205 R
72	16	30	37,6	52,1	1	5 300	0,34	361206 R
80	17	35	44	60,6	1,1	4 500	0,43	361207 R

Outside diameter D	Basic load ratings		Fatigue load limit P_u	Maximum radial loads	
	dynamic C	static C_0		dynamic F_r	static F_{0r}
mm	kN		kN	kN	
32	4,62	2	0,085	3,4	4,9
35	6,24	2,6	0,11	3,25	4,65
40	7,02	3,2	0,134	5	7,2
47	8,84	4,15	0,176	8,15	11,6
52	11,4	5,4	0,228	7,35	10,6
62	12,7	6,8	0,285	12,9	18,3
72	17,4	9,3	0,4	14,3	20,4
80	22,1	11,8	0,5	12,7	18



Angular contact ball bearings



Single row angular contact ball bearings..... 409

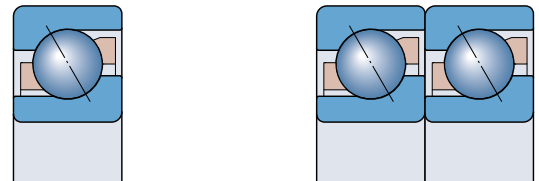

Double row angular contact ball bearings 433



Four-point contact ball bearings 451

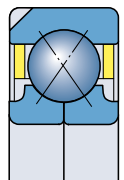

Double row cam rollers 463

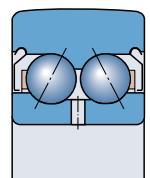

Angular contact ball bearings

Angular contact ball bearings have raceways in the inner and outer rings that are displaced with respect to each other in the direction of the bearing axis. This means that they are designed to accommodate combined loads, i.e. simultaneously acting radial and axial loads.

The axial load carrying capacity of angular contact ball bearings increases with increasing contact angle. The contact angle is defined as the angle between the line joining the points of contact of the ball and the raceways in the radial plane, along which the load is transmitted from one raceway to another, and a line perpendicular to the bearing axis.

SKF angular contact ball bearings are produced in a wide variety of designs and sizes. Those commonly used in general engineering are

- single row angular contact ball bearings (→ **fig. 1**)
- double row angular contact ball bearings (→ **fig. 2**)
- four-point contact ball bearings (→ **fig. 3**)
- double row cam rollers (→ **fig. 4**).

Detailed information about these bearing and cam rollers belonging to the SKF standard assortment is provided on the following pages.

Fig. 2

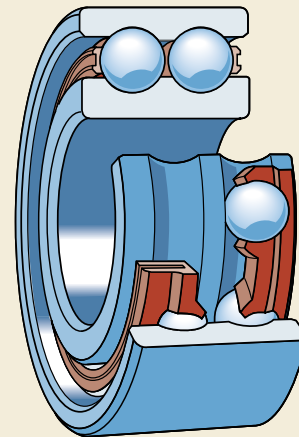

Fig. 3

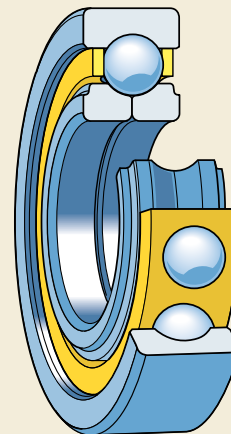

Fig. 1

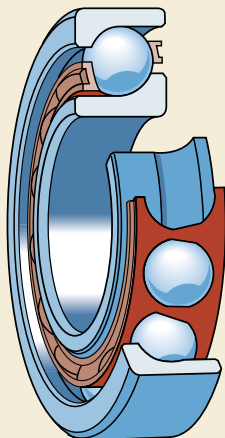
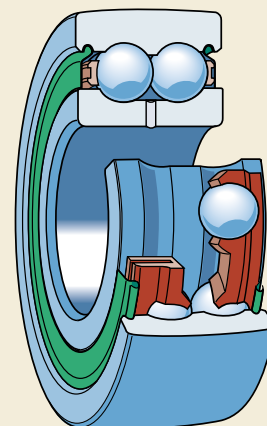

Fig. 4



Other SKF angular contact ball bearings

Angular contact ball bearings listed in this catalogue constitute the basic SKF assortment and are only part of the total range of SKF angular contact ball bearings. Other products also belonging to the range are briefly described in the following.

High-precision angular contact ball bearings

The comprehensive range of SKF high-precision angular contact ball bearings covers bearings in three different Dimension Series and a wide range of different design variants. It includes single bearings, universally matchable bearings and matched bearing sets

- without or with low-friction seals
- with three different contact angles
- with steel or ceramic balls
- in standard design (→ **fig. 5**) or high-speed design.

Fixed section angular contact ball bearings

These bearings have very thin rings and a constant cross section within a particular series, irrespective of the bearing size. They are further characterized by low weight and high stiffness. SKF fixed section bearings (→ **fig. 6**) are inch dimension bearings and available as either open or sealed

- single row angular contact ball bearings
- four-point contact ball bearings

in up to eight different cross sections.

Hub bearings units

Hub bearings units (HBU) for the automotive industry are based on double row angular contact ball bearings (→ **fig. 7**). They have made an appreciable contribution to the achievement of more compact weight-saving designs, simplified assembly and enhanced reliability.

Detailed information about these products will be supplied on request.

Fig. 5

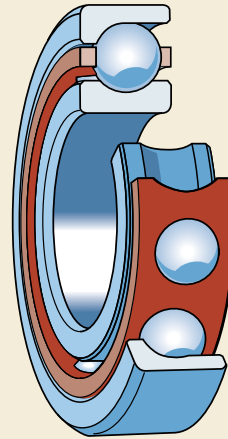

Fig. 6

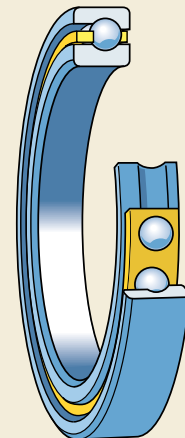
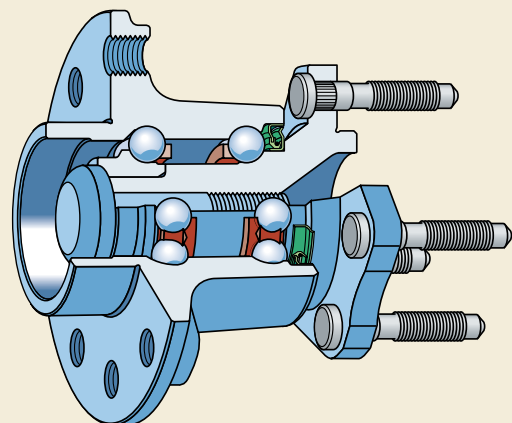

Fig. 7





Single row angular contact ball bearings

Designs	410
Basic design bearings	410
Bearings for universal matching.....	410
SKF Explorer class bearings	411
Bearing data – general	411
Dimensions.....	411
Tolerances.....	411
Internal clearance and preload	411
Misalignment.....	413
Influence of operating temperature on bearing material.....	413
Cages.....	413
Speed ratings for bearing pairs	413
Load carrying capacity of bearing pairs	414
Minimum load.....	414
Equivalent dynamic bearing load.....	415
Equivalent static bearing load.....	415
Determining axial force for bearings mounted singly or paired in tandem	415
Supplementary designations.....	417
Design of bearing arrangements	418
Product table	420

Designs

A single row angular contact ball bearing can accommodate axial loads acting in one direction only. The bearing is normally adjusted against a second bearing.

The standard assortment of SKF angular contact ball bearings comprises bearings in the 72 B and 73 B series. Two versions are available for different purposes

- basic design bearings (not universally matchable) – can only be used for arrangements with single bearings
- bearings for universal matching.

The bearings have a 40° contact angle (→ **fig. 1**) and therefore can support heavy axial loads. They are non-separable and the bearing rings have one high and one low shoulder. The low shoulder enables a large number of balls to be incorporated in the bearing, thus giving the bearing a relatively high load carrying capacity.

In addition, SKF single row angular contact ball bearings are available in many other dimension series, designs, and sizes. For further information about these bearings, consult the “SKF Interactive Engineering Catalogue” on CD-ROM or online at www.skf.com.

Basic design bearings

Basic design single row angular contact ball bearings are intended for arrangements where only one bearing is used at each bearing position. They have Normal tolerances concerning bearing width and standout of the rings. Therefore, they are not suitable for mounting directly adjacent to each other.

Bearings for universal matching

Bearings for universal matching are specifically manufactured so that when mounted in random order, but immediately adjacent to each other, a given internal clearance or preload and/or an even load distribution will be obtained without the use of shims or similar devices. Universally matchable bearings carry a designation suffix to indicate the internal clearance (CA, CB, CC) or preload (GA, GB, GC) of a set of two, prior to mounting.

When ordering, it is necessary to state the number of individual bearings required and not the number of sets.

Paired mounting (→ **fig. 2**) is used when the load carrying capacity of a single bearing is inadequate (tandem arrangement) or when combined or axial loads act in both directions (back-to-back and face-to-face arrangements).

When arranged in tandem (**a**) the load lines are parallel and the radial and axial loads are equally shared by the bearings. However, the bearing set can only accommodate axial loads acting in one direction. If axial loads act in the opposite direction, or if combined loads are present, a third bearing adjusted against the tandem pair must be added.

The load lines of bearings arranged back-to-back (**b**) diverge towards the bearing axis. Axial loads acting in both directions can be accommodated, but only by one bearing in each direction. Bearings mounted back-to-back provide a relatively stiff bearing arrangement that can also accommodate tilting moments.

The load lines of bearings mounted face-to-face (**c**) converge towards the bearing axis. Axial loads acting in both directions can be accommodated, but only by one bearing in each direction. This arrangement is not as stiff as the back-to-back arrangement and is less suitable for the accommodation of tilting moments.

Bearings for universal matching can also be beneficial in arrangements with single bearings. Most bearings are SKF Explorer and as such have higher precision, increased carrying capacity and speed capability.

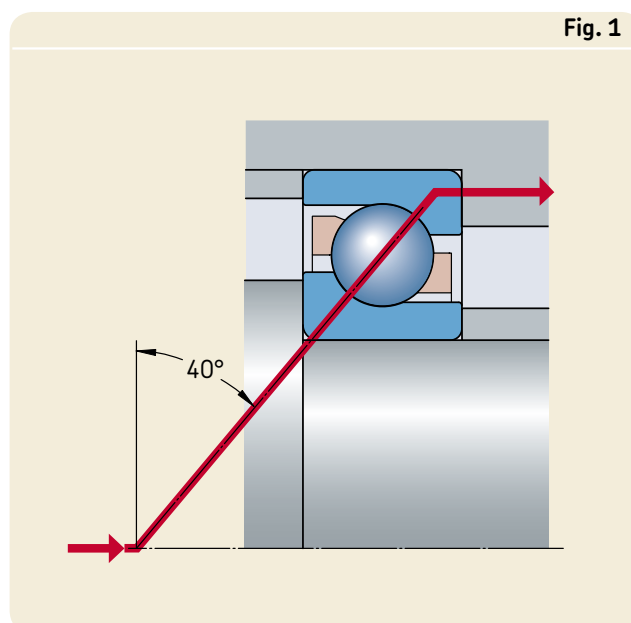

SKF Explorer class bearings

High performance SKF Explorer angular contact ball bearings are shown with an asterisk in the product table. SKF Explorer bearings retain the designation of the earlier standard bearings, e.g. 7208 BECBP. However, each bearing and its box are marked with the name “EXPLORER”.

Bearing data – general

Dimensions

The boundary dimensions of SKF single row angular contact ball bearings are in accordance with ISO 15:1998.

Tolerances

Basic design SKF single row angular contact ball bearings for single mounting are produced to Normal tolerances. Standard design universally matchable bearings are manufactured to better than Normal tolerances.

SKF Explorer angular contact ball bearings are manufactured only as bearings for universal matching with P6 dimensional accuracy and P5 running accuracy.

The values for tolerances correspond to ISO 492:2002 and can be found in **tables 3 to 5**, starting on **page 125**.

Internal clearance and preload

Internal clearance in single row angular contact ball bearings is only obtained after mounting and is dependent on adjustment against a second bearing, which provides axial location in the opposite direction.

SKF universally matchable bearings are produced in three different clearance and preload classes each. The classes for bearing sets with clearance are

- CA – smaller than Normal axial clearance
- CB – Normal axial clearance (standard)
- CC – larger than Normal axial clearance.

Bearings to clearance class CB are standard. The availability of bearings to other clearance classes can be obtained from **matrix 1** on **page 419**. SKF universally matchable bearings with clearance can be combined in sets of any number of bearings.

The classes for bearing sets with preload are

- GA – light preload (standard)
- GB – moderate preload
- GC – heavy preload.

Bearings to GA class preload are standard (→ **matrix 1** on **page 419**). Bearings with preload can only be paired in sets of two bearings, in contrast to the SKF universally matchable bearings with clearance, as otherwise the preload would increase.

Fig. 2

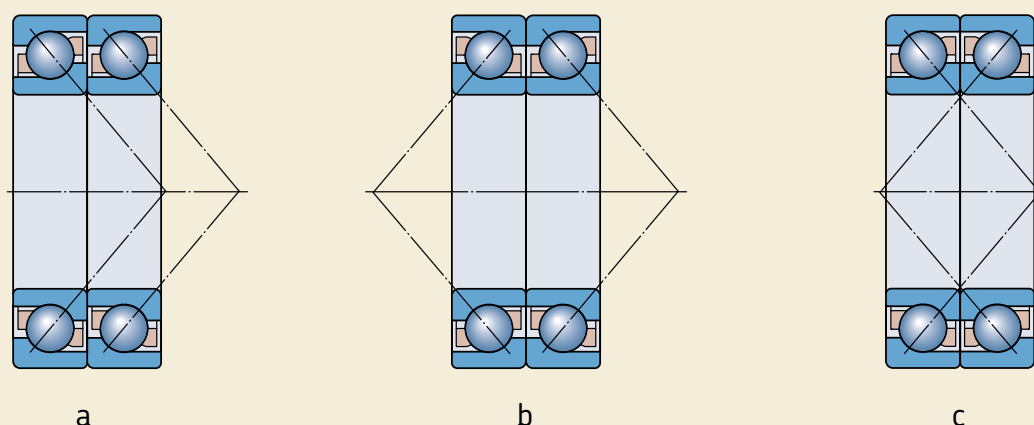

Single row angular contact ball bearings

The values for the clearance classes are provided in **table 1** and for the preload classes in **table 2**. The values apply to unmounted bearing sets, arranged back-to-back or face-to-face, and in case of clearance to zero measuring loads.

Table 1

Axial internal clearance of universally matchable single row angular contact ball bearings arranged back-to-back or face-to-face

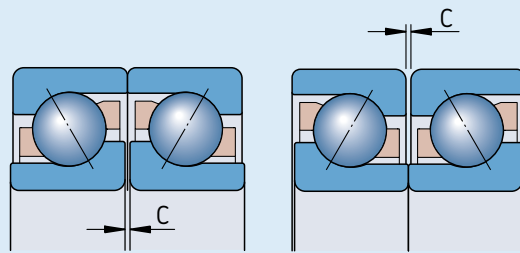

Bore diameter d		Axial internal clearance Class					
over	incl.	CA		CB		CC	
		min	max	min	max	min	max
mm		µm					
10	18	5	13	15	23	24	32
18	30	7	15	18	26	32	40
30	50	9	17	22	30	40	48
50	80	11	23	26	38	48	60
80	120	14	26	32	44	55	67
120	180	17	29	35	47	62	74
180	250	21	37	45	61	74	90

Table 2

Preload of universally matchable single row angular contact ball bearings arranged back-to-back or face-to-face

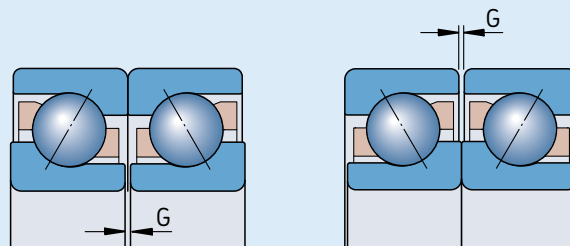

Bore diameter d		Preload Class GA			GB		GC		GC		GC	
over	incl.	min	max	max	min	max	min	max	min	max	min	max
mm		µm			µm		N		µm		N	
10	18	+4	-4	80	-2	-10	30	330	-8	-16	230	660
18	30	+4	-4	120	-2	-10	40	480	-8	-16	340	970
30	50	+4	-4	160	-2	-10	60	630	-8	-16	450	1 280
50	80	+6	-6	380	-3	-15	140	1 500	-12	-24	1 080	3 050
80	120	+6	-6	410	-3	-15	150	1 600	-12	-24	1 150	3 250
120	180	+6	-6	540	-3	-15	200	2 150	-12	-24	1 500	4 300
180	250	+8	-8	940	-4	-20	330	3 700	-16	-32	2 650	7 500

Misalignment

Single row angular contact ball bearings have only limited ability to accommodate misalignment. The permissible misalignment of the shaft relative to the housing that will not produce inadmissibly heavy additional forces, depends on the operating clearance in the bearing, bearing size, internal design and the forces and moments acting on the bearing. Because of the complex relationship between the influencing factors, it is not possible to quote any values that are universally valid.

For bearings mounted in sets, particularly those with small axial internal clearance mounted in a back-to-back arrangement, misalignment can only be accommodated by increased ball loads, which will create cage stresses and reduce bearing service life. Any misalignment of the bearing rings will also lead to increased running noise.

Influence of operating temperature on bearing material

SKF angular contact ball bearings undergo a special heat treatment. When fitted with a steel, brass or PEEK cage, they can operate at temperatures of up to +150 °C.

Cages

Depending on the bearing series and size, SKF single row angular contact ball bearings are fitted as standard with one of the following cages (→ fig. 3)

- an injection moulded window-type cage of glass fibre reinforced polyamide 6,6, ball centred, designation suffix P (a)
- an injection moulded window-type cage of polyetheretherketone (PEEK), ball centred, designation suffix PH
- a pressed window-type brass cage, ball centred, designation suffix Y (b)
- a machined window-type brass cage, ball centred, designation suffix M (c).

The available SKF standard assortment is shown in **matrix 1** on **page 419**. If bearings with a PEEK cage are required other than listed, please consult SKF.

Bearings having a pressed window-type steel cage, designation suffix J, or a machined

window-type steel cage, designation suffix F, may also be available. Please check availability prior to ordering.

Note

Bearings with polyamide 6,6 cages can be operated at temperatures up to +120 °C. The lubricants generally used for rolling bearings do not have a detrimental effect on cage properties, with the exception of a few synthetic oils and greases with a synthetic oil base, and lubricants containing a high proportion of EP additives when used at high temperatures.

For detailed information about the temperature resistance and the applicability of cages, please refer to the section “Cage materials”, starting on **page 140**.

Speed ratings for bearing pairs

For bearings arranged in pairs, the reference speeds provided in the product table for single bearings should be reduced by approximately 20 %.

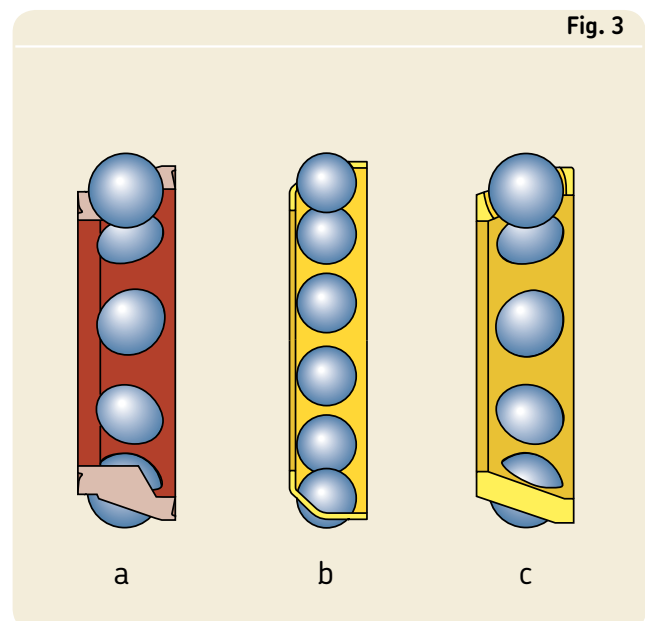

Single row angular contact ball bearings

Load carrying capacity of bearing pairs

The values for basic load ratings and fatigue load limits provided in the product table apply to single bearings. For bearing pairs mounted immediately adjacent to each other the following values apply

- basic dynamic load rating for standard bearings in all arrangements and for SKF Explorer bearings in back-to-back or face-to-face arrangement

$$C = 1,62 \times C_{\text{single bearing}}$$

- basic dynamic load rating for SKF Explorer bearings in tandem arrangement

$$C = 2 \times C_{\text{single bearing}}$$

- basic static load rating

$$C_0 = 2 \times C_{0 \text{ single bearing}}$$

- fatigue load limit

$$P_u = 2 \times P_{u \text{ single bearing}}$$

Minimum load

In order to provide satisfactory operation, angular contact ball bearings, like all ball and roller bearings, must always be subjected to a given minimum load, particularly if they are to operate at high speeds or are subjected to high accelerations or rapid changes in the direction of load. Under such conditions, the inertia forces of the balls and cage, and the friction in the lubricant, have a detrimental influence on the rolling conditions in the bearing arrangement and may cause damaging sliding movements to occur between the balls and raceways.

The requisite minimum load to be applied to single bearings and bearing pairs arranged in tandem can be estimated using

$$F_{am} = k_a \frac{C_0}{1\,000} \left(\frac{n d_m}{100\,000} \right)^2$$

and for bearing pairs arranged back-to-back or face-to-face from

$$F_{rm} = k_r \left(\frac{v n}{1\,000} \right)^{2/3} \left(\frac{d_m}{100} \right)^2$$

Table 3

Minimum load factors

Bearing series	Minimum load factors	
	k_a	k_r
72 BE	1,4	0,095
72 B	1,2	0,08
73 BE	1,6	0,1
73 B	1,4	0,09

where

F_{am} = minimum axial load, kN

F_{rm} = minimum radial load, kN

C_0 = basic static load rating of single bearing, or bearing pair, kN (→ product table)

k_a = minimum axial load factor according to **table 3**

k_r = minimum radial load factor according to **table 3**

v = oil viscosity at operating temperature, mm^2/s

n = rotational speed, r/min

d_m = bearing mean diameter
= $0,5 (d + D)$, mm

When starting up at low temperatures or when the lubricant is highly viscous, even greater minimum loads may be required. The weight of the components supported by the bearing, together with external forces, generally exceeds the requisite minimum load. If this is not the case, the angular contact ball bearing must be subjected to an additional load. Single bearings and bearing pairs arranged in tandem can be axially preloaded by adjusting the inner or outer rings against each other, or by using springs.

Equivalent dynamic bearing load

For single bearings and bearings paired in tandem

$$P = F_r \quad \text{when } F_a/F_r \leq 1,14$$
$$P = 0,35 F_r + 0,57 F_a \quad \text{when } F_a/F_r > 1,14$$

When determining the axial force F_a , reference should be made to the section "Determining axial force for bearings mounted singly or paired in tandem".

For bearings mounted in pairs, arranged back-to-back or face-to-face

$$P = F_r + 0,55 F_a \quad \text{when } F_a/F_r \leq 1,14$$
$$P = 0,57 F_r + 0,93 F_a \quad \text{when } F_a/F_r > 1,14$$

F_r and F_a are the forces acting on the bearing pair.

Equivalent static bearing load

For single bearings and bearings paired in tandem

$$P_0 = 0,5 F_r + 0,26 F_a$$

If $P_0 < F_r$, then $P_0 = F_r$ should be used. When determining the axial force F_a reference should be made to the section "Determining axial force for bearings mounted singly or paired in tandem".

For bearings mounted in pairs, arranged back-to-back or face-to-face

$$P_0 = F_r + 0,52 F_a$$

F_r and F_a are the forces acting on the bearing pair.

Determining axial force for bearings mounted singly or paired in tandem

When a radial load is applied, the load is transmitted from one raceway to the other at an angle to the bearing axis and an internal axial force will be induced in single row angular contact ball bearings. This must be considered when calculating the equivalent bearing loads for bearing arrangements consisting of two single bearings and/or bearing pairs arranged in tandem.

The necessary equations are provided in **table 4, page 416**, for the various bearing arrangements and load cases. The equations are only valid if the bearings are adjusted against each other to practically zero clearance, but without any preload. In the arrangements shown, bearing A is subjected to a radial load F_{rA} and bearing B to a radial load F_{rB} . Both F_{rA} and F_{rB} are always considered positive, even when they act in the direction opposite to that shown in the figures. The radial loads act at the pressure centres of the bearings (see dimension a in the product table).

Variable R

The variable R from **table 4** takes into account the contact conditions inside the bearing. The values for R can be obtained from **diagram 1, page 417**, as a function of the ratio K_a/C . K_a is the external axial load acting on the shaft or on the housing and C is the basic dynamic load rating of the bearing, which must accommodate the external axial load. For $K_a = 0$ use $R = 1$.

Single row angular contact ball bearings

Table 4

Axial loading of bearing arrangements incorporating two single row B or BE design angular contact ball bearings and/or bearing pairs in tandem

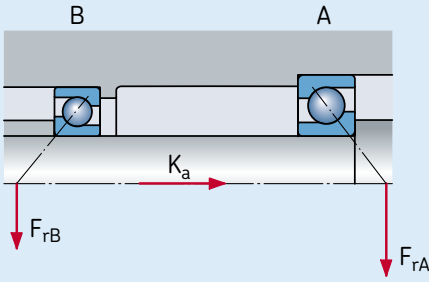
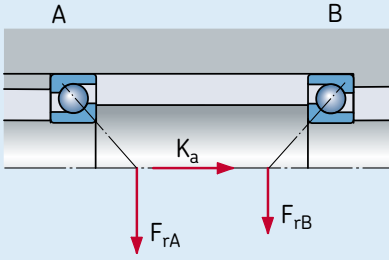
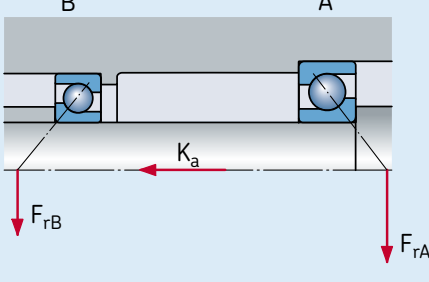
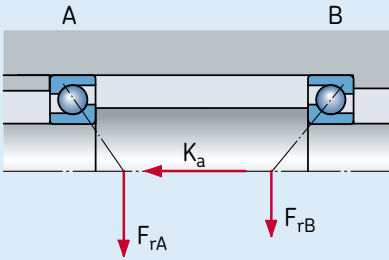
Bearing arrangement	Load case	Axial forces	
<p>Back-to-back</p> 	<p>Case 1a</p> $F_{rA} \geq F_{rB}$ $K_a \geq 0$	$F_{aA} = R F_{rA}$	$F_{aB} = F_{aA} + K_a$
	<p>Case 1b</p> $F_{rA} < F_{rB}$ $K_a \geq R(F_{rB} - F_{rA})$	$F_{aA} = R F_{rA}$	$F_{aB} = F_{aA} + K_a$
<p>Face-to-face</p> 	<p>Case 1c</p> $F_{rA} < F_{rB}$ $K_a < R(F_{rB} - F_{rA})$	$F_{aA} = F_{aB} - K_a$	$F_{aB} = R F_{rB}$
<p>Back-to-back</p> 	<p>Case 2a</p> $F_{rA} \leq F_{rB}$ $K_a \geq 0$	$F_{aA} = F_{aB} + K_a$	$F_{aB} = R F_{rB}$
	<p>Case 2b</p> $F_{rA} > F_{rB}$ $K_a \geq R(F_{rA} - F_{rB})$	$F_{aA} = F_{aB} + K_a$	$F_{aB} = R F_{rB}$
<p>Face-to-face</p> 	<p>Case 2c</p> $F_{rA} > F_{rB}$ $K_a < R(F_{rA} - F_{rB})$	$F_{aA} = R F_{rA}$	$F_{aB} = F_{aA} - K_a$

Supplementary designations

The designation suffixes used to identify certain features of SKF single row angular contact ball bearings are explained in the following.

A	30° contact angle	GB	Bearing for universal matching. Two bearings arranged back-to-back or face-to-face will have a moderate preload before mounting
AC	25° contact angle	GC	Bearing for universal matching. Two bearings arranged back-to-back or face-to-face will have a heavy preload before mounting
B	40° contact angle	J	Pressed window-type steel cage, ball centred
CA	Bearing for universal matching. Two bearings arranged back-to-back or face-to-face will have an axial internal clearance smaller than Normal (CB) before mounting	M	Machined window-type brass cage, ball centred, different designs are identified by a figure, e.g. M1
CB	Bearing for universal matching. Two bearings arranged back-to-back or face-to-face will have a Normal axial internal clearance before mounting	N1	One locating slot (notch) in the large outer ring side face
CC	Bearing for universal matching. Two bearings arranged back-to-back or face-to-face will have an axial internal clearance greater than Normal (CB) before mounting	N2	Two locating slots (notches), 180° apart, in the large outer ring side face
DB	Two bearings matched back-to-back	P	Injection moulded window-type cage of glass fibre reinforced polyamide 6,6, ball centred
DF	Two bearings matched face-to-face	PH	Injection moulded window-type cage of polyetheretherketone (PEEK), ball centred
DT	Two bearings matched in tandem	P5	Dimensional and running accuracy to ISO tolerance class 5
E	Optimized internal design	P6	Dimensional and running accuracy to ISO tolerance class 6
F	Machined window-type steel cage, ball centred	W64	Solid Oil filling
GA	Bearing for universal matching. Two bearings arranged back-to-back or face-to-face will have a light preload before mounting	Y	Pressed window-type brass cage, ball centred

Diagram 1

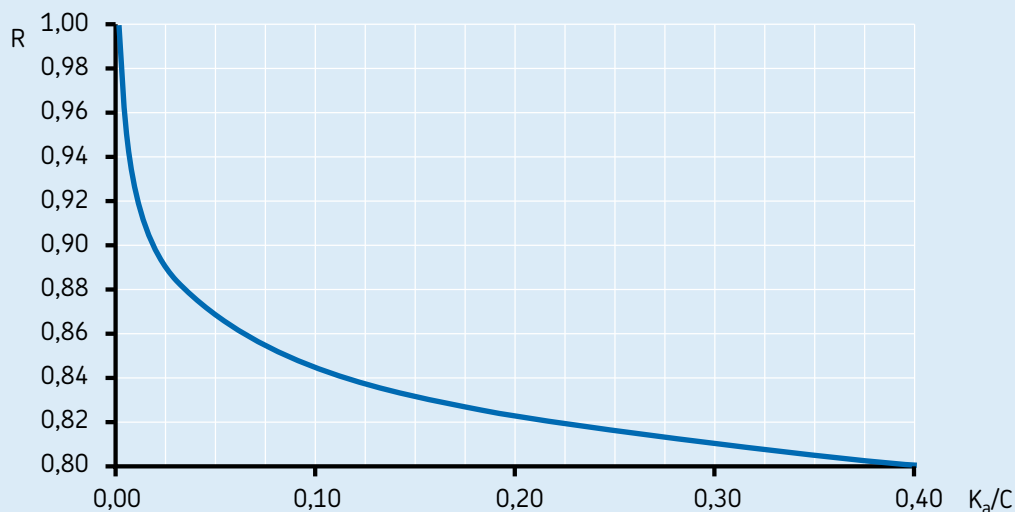

Design of bearing arrangements

When designing bearing arrangements incorporating single row angular contact ball bearings, remember that these bearings must either be used with a second bearing or in sets (→ **fig. 4**).

When two single row angular contact ball bearings are used, they must be adjusted against each other until the requisite preload or clearance is obtained (→ section “Bearing preload”, starting on **page 206**).

Where bearings for universal matching are used and the bearings are mounted immediately adjacent to each other, there is no need for adjustment. The requisite preload or clearance is obtained by choosing bearings from an appropriate preload or clearance class and by applying suitable fits for the bearings on the shaft and in the housing.

It is important for proper bearing performance and for the operational reliability of the arrangement that the bearings are correctly adjusted, or that the correct choice of preload or clearance has been made. If the clearance of the bearing in operation is too large, the load carrying capacity of the bearings will not be fully utilized; on the other hand, excessive preload will produce more friction and higher operating

temperatures, leading to a reduction in bearing service life. It should also be remembered that with 72 B and 73 B series single row angular contact ball bearings (40° contact angle), correct rolling conditions will only be achieved in the bearing when the load ratio $F_a/F_r \geq 1$.

Special attention should also be paid to back-to-back and face-to-face arrangements where the axial load acts predominantly in one direction. This creates an unfavourable rolling condition for the balls of the unloaded bearing and can lead to noise, discontinuity in the lubricant film and increased stressing of the cage. Under these conditions, zero operational clearance is recommended and should be attained, for example, by using springs. For additional information contact the SKF application engineering service.

Fig. 4

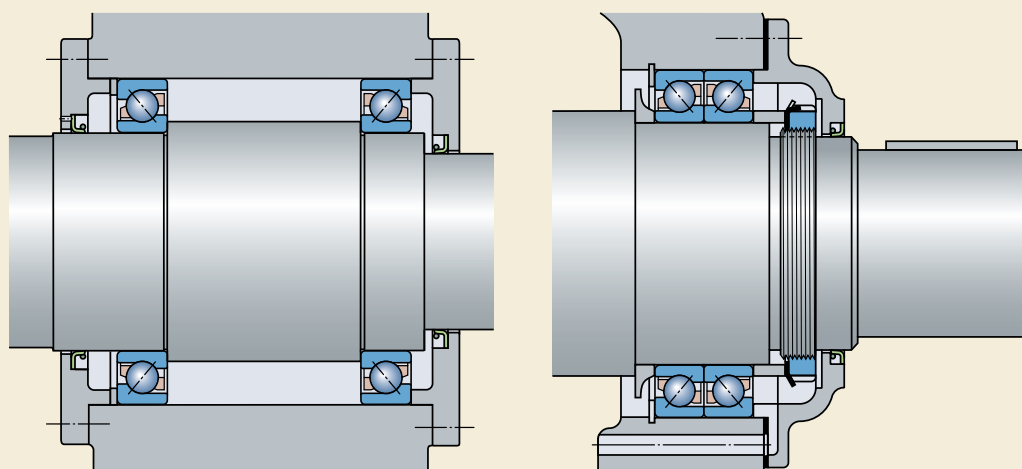

SKF single row angular contact ball bearings – standard assortment

Bore diameter, mm	Universally matchable bearings																Basic design bearings			Bearing size							
	72 BECBP	72 BEGAP	72 BEGBP	72 BECBY	72 BEGAY	72 B(E)CBM	72 B(E)GAM	73 BECAP	73 BECBP	73 BEGAP	73 BEGBP	73 BECBPH	73 BECBY	73 BEGBY	73 B(E)CBM	73 BECCM	73 BEGAM	73 B(E)GBM	72 BEP		72 BEY	72 B(E)M	73 BEP	73 BEY	73 B(E)M		
10																										00	
12																											01
15																											02
17																											03
20																											04
25																											05
30																											06
35																											07
40																											08
45																											09
50																											10
55																											11
60																											12
65																											13
70																											14
75																											15
80																											16
85																											17
90																											18
95																											19
100																											20
105																											21
110																											22
120																											24
130																											26
140																											28
150																											30
160																											32
170																											34
180																											36
190																											38
200																											40
220																											44
240																											48

 SKF Explorer bearings
 Other SKF standard bearings

For other dimension series, sizes and designs, please consult the “SKF Interactive Engineering Catalogue” on CD-ROM or online at www.skf.com

Single row angular contact ball bearings
d 10 – 25 mm

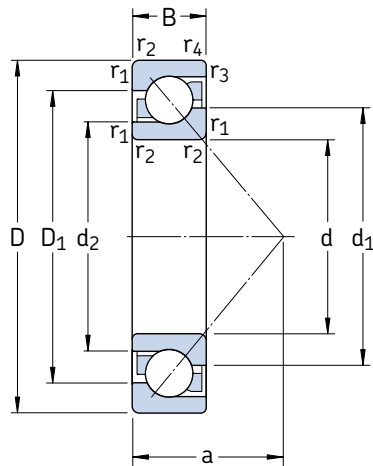

Principal dimensions			Basic load ratings		Fatigue load limit P_u	Speed ratings		Mass	Designations ¹⁾	
d	D	B	C	C_0		Refer- ence speed	Limiting speed		Universally matchable bearing	Basic design bearing
mm			kN		kN	r/min		kg	–	
10	30	9	7,02	3,35	0,14	30 000	30 000	0,030	7200 BECBP	7200 BEP
12	32 37	10 12	7,61 10,6	3,8 5	0,16 0,208	26 000 24 000	26 000 24 000	0,036 0,063	7201 BECBP –	7201 BEP 7301 BEP
15	35 35 42	11 11 13	9,5 8,84 13	5,1 4,8 6,7	0,216 0,204 0,28	26 000 24 000 20 000	26 000 24 000 20 000	0,045 0,045 0,081	* 7202 BECBP – 7302 BECBP	– 7202 BEP 7302 BEP
17	40 40 40 40 47	12 12 12 12 14	11 10,4 11,1 11 15,9	5,85 5,5 6,1 5,85 8,3	0,25 0,236 0,26 0,25 0,355	22 000 20 000 20 000 22 000 19 000	22 000 20 000 20 000 22 000 19 000	0,064 0,064 0,064 0,070 0,11	* 7203 BECBP – – * 7203 BECBM 7303 BECBP	– 7203 BEP 7203 BEY – 7303 BEP
20	47 47 47 47	14 14 14 14	14,3 13,3 14 13,3	8,15 7,65 8,3 7,65	0,345 0,325 0,355 0,325	19 000 18 000 18 000 18 000	19 000 18 000 18 000 19 000	0,11 0,11 0,11 0,11	* 7204 BECBP – 7204 BECBY 7204 BECBM	– 7204 BEP – –
	52 52 52 52	15 15 15 15	19 17,4 19 19	10 9,5 10,4 10	0,425 0,4 0,44 0,425	18 000 16 000 16 000 18 000	18 000 16 000 16 000 18 000	0,14 0,14 0,15 0,15	* 7304 BECBP – 7304 BECBY * 7304 BECBM	– 7304 BEP 7304 BEY –
25	52 52 52 52	15 15 15 15	15,6 14,8 15,6 15,6	10 9,3 10,2 10	0,43 0,4 0,43 0,43	17 000 15 000 15 000 17 000	17 000 15 000 15 000 17 000	0,13 0,13 0,13 0,14	* 7205 BECBP – 7205 BECBY * 7205 BECBM	– 7205 BEP 7205 BEY –
	62 62 62 62	17 17 17 17	26,5 24,2 26 26,5	15,3 14 15,6 15,3	0,655 0,6 0,655 0,655	15 000 14 000 14 000 15 000	15 000 14 000 14 000 15 000	0,23 0,23 0,24 0,24	* 7305 BECBP – 7305 BECBY * 7305 BECBM	– 7305 BEP 7305 BEY –

* SKF Explorer bearing

¹⁾ For available final variants → **matrix 1** on page 419

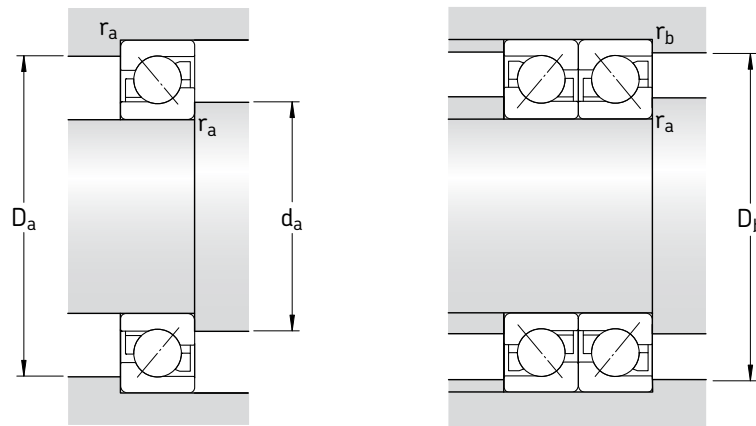

Dimensions

Abutment and fillet dimensions

d	d ₁ ~	d ₂ ~	D ₁ ~	r _{1,2} min	r _{3,4} min	a	d _a min	D _a max	D _b max	r _a max	r _b max
mm							mm				
10	18,3	14,6	22,9	0,6	0,3	13	14,2	25,8	27,6	0,6	0,3
12	20,2 21,8	16,6 17	25 28,3	0,6 1	0,3 0,6	14,4 16,3	16,2 17,6	27,8 31,4	29,6 32,8	0,6 1	0,3 0,6
15	22,7 22,7 26	19 19 20,7	27,8 27,8 32,6	0,6 0,6 1	0,3 0,3 0,6	16 16 18,6	19,2 19,2 20,6	30,8 30,8 36,4	32,6 32,6 37,8	0,6 0,6 1	0,3 0,3 0,6
17	26,3 26,3 26,3 26,3 28,7	21,7 21,7 21,7 21,7 22,8	31,2 31,2 31,2 31,2 36,2	0,6 0,6 0,6 0,6 1	0,6 0,6 0,6 0,6 0,6	18 18 18 18 20,4	21,2 21,2 21,2 21,2 22,6	35,8 35,8 35,8 35,8 41,4	35,8 35,8 35,8 35,8 42,8	0,6 0,6 0,6 0,6 1	0,6 0,6 0,6 0,6 0,6
20	30,8 30,8 30,8 30,8	25,9 25,9 25,9 25,9	36,5 36,5 36,5 36,5	1 1 1 1	0,6 0,6 0,6 0,6	21 21 21 21	25,6 25,6 25,6 25,6	41,4 41,4 41,4 41,4	42,8 42,8 42,8 42,8	1 1 1 1	0,6 0,6 0,6 0,6
	33,3 33,3 33,3 33,3	26,8 26,8 26,8 26,8	40,4 40,4 40,4 40,4	1,1 1,1 1,1 1,1	0,6 0,6 0,6 0,6	22,8 22,8 22,8 22,8	27 27 27 27	45 45 45 45	47,8 47,8 47,8 47,8	1 1 1 1	0,6 0,6 0,6 0,6
25	36,1 36,1 36,1 36,1	30,9 30,9 30,9 30,9	41,5 41,5 41,5 41,5	1 1 1 1	0,6 0,6 0,6 0,6	23,7 23,7 23,7 23,7	30,6 30,6 30,6 30,6	46,4 46,4 46,4 46,4	47,8 47,8 47,8 47,8	1 1 1 1	0,6 0,6 0,6 0,6
	39,8 39,8 39,8 39,8	32,4 32,4 32,4 32,4	48,1 48,1 48,1 48,1	1,1 1,1 1,1 1,1	0,6 0,6 0,6 0,6	26,8 26,8 26,8 26,8	32 32 32 32	55 55 55 55	57,8 57,8 57,8 57,8	1 1 1 1	0,6 0,6 0,6 0,6

Single row angular contact ball bearings
d 30 – 45 mm

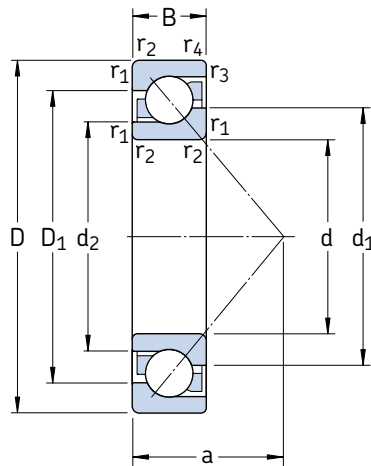

Principal dimensions			Basic load ratings		Fatigue load limit P_u	Speed ratings		Mass	Designations ¹⁾	
d	D	B	C	C_0		Refer- ence speed	Limiting speed		Universally matchable bearing	Basic design bearing
mm			kN		kN	r/min		kg	–	
30	62	16	24	15,6	0,655	14 000	14 000	0,19	* 7206 BECBP	–
	62	16	22,5	14,3	0,61	13 000	13 000	0,19	–	7206 BEP
	62	16	23,8	15,6	0,655	13 000	13 000	0,21	7206 BECBY	7206 BEY
	62	16	24	15,6	0,655	14 000	14 000	0,21	* 7206 BECBM	–
	72	19	35,5	21,2	0,9	13 000	13 000	0,33	* 7306 BECBP	–
	72	19	32,5	19,3	0,815	12 000	12 000	0,33	–	7306 BEP
	72	19	34,5	21,2	0,9	12 000	12 000	0,37	7306 BECBY	7306 BEY
	72	19	35,5	21,2	0,9	13 000	13 000	0,37	* 7306 BECBM	–
35	72	17	31	20,8	0,88	12 000	12 000	0,28	* 7207 BECBP	–
	72	17	29,1	19	0,815	11 000	11 000	0,28	–	7207 BEP
	72	17	30,7	20,8	0,88	11 000	11 000	0,30	7207 BECBY	7207 BEY
	72	17	31	20,8	0,88	12 000	12 000	0,30	* 7207 BECBM	–
	80	21	41,5	26,5	1,14	11 000	11 000	0,45	* 7307 BECBP	–
	80	21	39	24,5	1,04	10 000	10 000	0,45	–	7307 BEP
	80	21	39	24,5	1,04	10 000	10 000	0,49	7307 BECBY	7307 BEY
	80	21	41,5	26,5	1,14	11 000	11 000	0,49	* 7307 BECBM	–
40	80	18	36,5	26	1,1	11 000	11 000	0,37	* 7208 BECBP	–
	80	18	34,5	24	1,02	10 000	10 000	0,37	–	7208 BEP
	80	18	36,4	26	1,1	10 000	10 000	0,38	7208 BECBY	7208 BEY
	80	18	36,5	26	1,1	11 000	11 000	0,39	* 7208 BECBM	–
	80	18	34,5	24	1,02	10 000	10 000	0,39	–	7208 BEM
	90	23	50	32,5	1,37	10 000	10 000	0,61	* 7308 BECBP	–
	90	23	46,2	30,5	1,13	9 000	9 000	0,61	–	7308 BEP
	90	23	49,4	33,5	1,4	9 000	9 000	0,64	7308 BECBY	7308 BEY
45	85	19	38	28,5	1,22	10 000	10 000	0,42	* 7209 BECBP	–
	85	19	35,8	26	1,12	9 000	9 000	0,42	–	7209 BEP
	85	19	37,7	28	1,2	9 000	9 000	0,43	7209 BECBY	7209 BEY
	85	19	38	28,5	1,22	10 000	10 000	0,44	* 7209 BECBM	–
	100	25	61	40,5	1,73	9 000	9 000	0,82	* 7309 BECBP	–
	100	25	55,9	37,5	1,73	8 000	8 000	0,82	–	7309 BEP
	100	25	60,5	41,5	1,73	8 000	8 000	0,86	7309 BECBY	7309 BEY
	100	25	61	40,5	1,73	9 000	9 000	0,90	* 7309 BECBM	–

* SKF Explorer bearing

¹⁾ For available final variants → matrix 1 on page 419

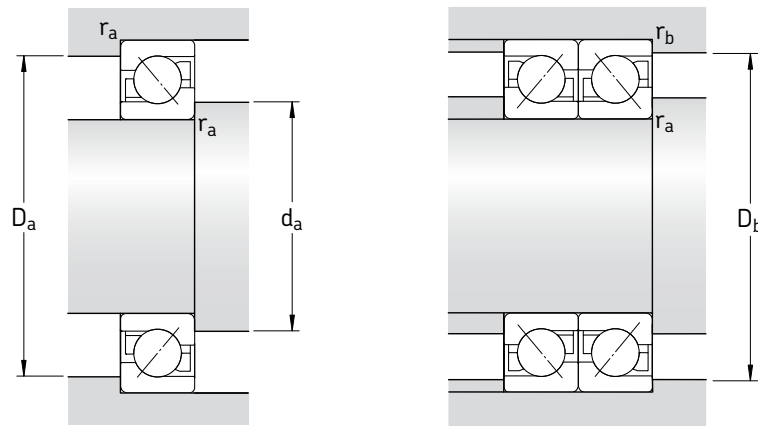

Dimensions

Abutment and fillet dimensions

d	$\underset{\sim}{d_1}$	$\underset{\sim}{d_2}$	$\underset{\sim}{D_1}$	$r_{1,2}$ min	$r_{3,4}$ min	a	d_a min	D_a max	D_b max	r_a max	r_b max
mm							mm				
30	42,7	36,1	50,1	1	0,6	27,3	35,6	56,4	57,8	1	0,6
	42,7	36,1	50,1	1	0,6	27,3	35,6	56,4	57,8	1	0,6
	42,7	36,1	50,1	1	0,6	27,3	35,6	56,4	57,8	1	0,6
	42,7	36,1	50,1	1	0,6	27,3	35,6	56,4	57,8	1	0,6
	46,6	37,9	56,5	1,1	0,6	31	37	65	67,8	1	0,6
	46,6	37,9	56,5	1,1	0,6	31	37	65	67,8	1	0,6
	46,6	37,9	56,5	1,1	0,6	31	37	65	67,8	1	0,6
	46,6	37,9	56,5	1,1	0,6	31	37	65	67,8	1	0,6
35	49,7	42	58,3	1,1	0,6	31	42	65	67,8	1	0,6
	49,7	42	58,3	1,1	0,6	31	42	65	67,8	1	0,6
	49,7	42	58,3	1,1	0,6	31	42	65	67,8	1	0,6
	49,7	42	58,3	1,1	0,6	31	42	65	67,8	1	0,6
	52,8	43,6	63,3	1,5	1	35	44	71	74,4	1,5	1
	52,8	43,6	63,3	1,5	1	35	44	71	74,4	1,5	1
	52,8	43,6	63,3	1,5	1	35	44	71	74,4	1,5	1
	52,8	43,6	63,3	1,5	1	35	44	71	74,4	1,5	1
40	56,3	48,1	65,6	1,1	0,6	34	47	73	75,8	1	0,6
	56,3	48,1	65,6	1,1	0,6	34	47	73	75,8	1	0,6
	56,3	48,1	65,6	1,1	0,6	34	47	73	75,8	1	0,6
	56,3	48,1	65,6	1,1	0,6	34	47	73	75,8	1	0,6
	59,7	49,6	71,6	1,5	1	39	49	81	84,4	1,5	1
	59,7	49,6	71,6	1,5	1	39	49	81	84,4	1,5	1
	59,7	49,6	71,6	1,5	1	39	49	81	84,4	1,5	1
	59,7	49,6	71,6	1,5	1	39	49	81	84,4	1,5	1
45	60,9	52,7	70,2	1,1	0,6	37	52	78	80,8	1	0,6
	60,9	52,7	70,2	1,1	0,6	37	52	78	80,8	1	0,6
	60,9	52,7	70,2	1,1	0,6	37	52	78	80,8	1	0,6
	60,9	52,7	70,2	1,1	0,6	37	52	78	80,8	1	0,6
	66,5	55,3	79,8	1,5	1	43	54	91	94,4	1,5	1
	66,5	55,3	79,8	1,5	1	43	54	91	94,4	1,5	1
	66,5	55,3	79,8	1,5	1	43	54	91	94,4	1,5	1
	66,5	55,3	79,8	1,5	1	43	54	91	94,4	1,5	1

Single row angular contact ball bearings
d 50 – 65 mm

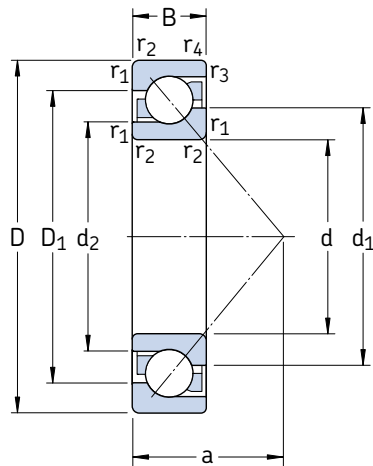

Principal dimensions			Basic load ratings		Fatigue load limit P_u	Speed ratings		Mass	Designations ¹⁾	
d	D	B	dynamic C	static C_0		Refer- ence speed	Limiting speed		Universally matchable bearing	Basic design bearing
mm			kN		kN	r/min		kg	–	
50	90	20	40	31	1,32	9 000	9 000	0,47	* 7210 BECBP	–
	90	20	37,7	28,5	1,22	8 500	8 500	0,47	–	7210 BEP
	90	20	39	30,5	1,29	8 500	8 500	0,47	7210 BECBY	7210 BEY
	90	20	40	31	1,32	9 000	9 000	0,51	* 7210 BECBM	–
	110	27	75	51	2,16	8 000	8 000	1,04	* 7310 BECBP	–
	110	27	68,9	47,5	2	7 500	7 500	1,04	–	7310 BEP
	110	27	74,1	51	2,2	7 500	7 500	1,13	7310 BECBY	7310 BEY
	110	27	75	51	2,16	8 000	8 000	1,16	* 7310 BECBM	–
55	100	21	49	40	1,66	8 000	8 000	0,62	* 7211 BECBP	–
	100	21	46,2	36	1,53	7 500	7 500	0,62	–	7211 BEP
	100	21	48,8	38	1,63	7 500	7 500	0,62	7211 BECBY	7211 BEY
	100	21	49	40	1,66	8 000	8 000	0,66	* 7211 BECBM	–
	120	29	85	60	2,55	7 000	7 000	1,34	* 7311 BECBP	–
	120	29	79,3	55	2,32	6 700	6 700	1,34	–	7311 BEP
	120	29	85,2	60	2,55	6 700	6 700	1,48	7311 BECBY	7311 BEY
	120	29	85	60	2,55	7 000	7 000	1,49	* 7311 BECBM	–
60	110	22	61	50	2,12	7 500	7 500	0,78	* 7212 BECBP	–
	110	22	57,2	45,5	1,93	7 000	7 000	0,78	–	7212 BEP
	110	22	57,2	45,5	1,93	7 000	7 000	0,83	7212 BECBY	7212 BEY
	110	22	61	50	2,12	7 500	7 500	0,85	* 7212 BECBM	–
	130	31	104	76,5	3,2	6 700	6 700	1,71	* 7312 BECBP	–
	130	31	95,6	69,5	3	6 000	6 000	1,71	–	7312 BEP
	130	31	95,6	69,5	3	6 000	6 000	1,75	7312 BECBY	7312 BEY
	130	31	104	76,5	3,2	6 700	6 700	1,88	* 7312 BECBM	–
	130	31	95,6	69,5	3	6 000	6 300	1,88	–	7312 BEM
	65	120	23	66,3	54	2,28	6 300	6 300	1,00	7213 BECBP
65	120	23	66,3	54	2,28	6 300	6 300	1,00	7213 BECBY	7213 BEY
65	120	23	66,3	54	2,28	6 300	6 700	1,10	7213 BECBM	–
65	140	33	116	86,5	3,65	6 300	6 300	2,10	* 7313 BECBP	–
65	140	33	108	80	3,35	5 600	5 600	2,15	7313 BECBY	7313 BEP
65	140	33	116	86,5	3,65	6 300	6 300	2,31	* 7313 BECBM	–

* SKF Explorer bearing

¹⁾ For available final variants → matrix 1 on page 419

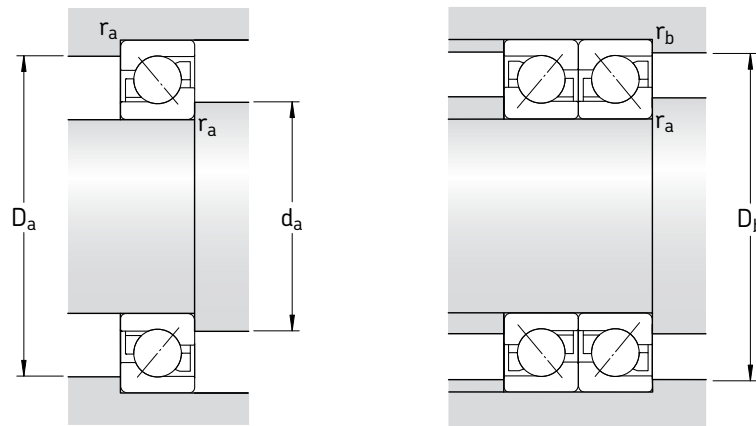

Dimensions

Abutment and fillet dimensions

d	$\underset{\sim}{d_1}$	$\underset{\sim}{d_2}$	$\underset{\sim}{D_1}$	$r_{1,2}$ min	$r_{3,4}$ min	a	d_a min	D_a max	D_b max	r_a max	r_b max
mm							mm				
50	65,8	57,7	75,2	1,1	0,6	39	57	83	85,8	1	0,6
	65,8	57,7	75,2	1,1	0,6	39	57	83	85,8	1	0,6
	65,8	57,7	75,2	1,1	0,6	39	57	83	85,8	1	0,6
	65,8	57,7	75,2	1,1	0,6	39	57	83	85,8	1	0,6
	73,8	61,1	88,8	2	1	47	61	99	104	2	1
	73,8	61,1	88,8	2	1	47	61	99	104	2	1
	73,8	61,1	88,8	2	1	47	61	99	104	2	1
	73,8	61,1	88,8	2	1	47	61	99	104	2	1
55	72,7	63,6	83,3	1,5	1	43	64	91	94	1,5	1
	72,7	63,6	83,3	1,5	1	43	64	91	94	1,5	1
	72,7	63,6	83,3	1,5	1	43	64	91	94	1,5	1
	72,7	63,6	83,3	1,5	1	43	64	91	94	1,5	1
	80,3	66,7	96,6	2	1	51	66	109	114	2	1
	80,3	66,7	96,6	2	1	51	66	109	114	2	1
	80,3	66,7	96,6	2	1	51	66	109	114	2	1
	80,3	66,7	96,6	2	1	51	66	109	114	2	1
60	79,6	69,3	91,55	1,5	1	47	69	101	104	1,5	1
	79,6	69,3	91,6	1,5	1	47	69	101	104	1,5	1
	79,6	69,3	91,6	1,5	1	47	69	101	104	1,5	1
	79,6	69,3	91,6	1,5	1	47	69	101	104	1,5	1
	87,3	72,6	104,8	2,1	1,1	55	72	118	123	2	1
	87,3	72,6	104,8	2,1	1,1	55	72	118	123	2	1
	87,3	72,6	104,8	2,1	1,1	55	72	118	123	2	1
	87,3	72,6	104,8	2,1	1,1	55	72	118	123	2	1
	87,3	72,6	104,8	2,1	1,1	55	72	118	123	2	1
	87,3	72,6	104,8	2,1	1,1	55	72	118	123	2	1
65	86,4	75,5	100	1,5	1	50	74	111	114	1,5	1
	86,4	75,5	100	1,5	1	50	74	111	114	1,5	1
	86,4	75,5	100	1,5	1	50	74	111	114	1,5	1
	94,2	78,5	112,9	2,1	1,1	60	77	128	133	2	1
	94,2	78,5	112,9	2,1	1,1	60	77	128	133	2	1
	94,2	78,5	112,9	2,1	1,1	60	77	128	133	2	1
	94,2	78,5	112,9	2,1	1,1	60	77	128	133	2	1
	94,2	78,5	112,9	2,1	1,1	60	77	128	133	2	1

Single row angular contact ball bearings
d 70 – 85 mm

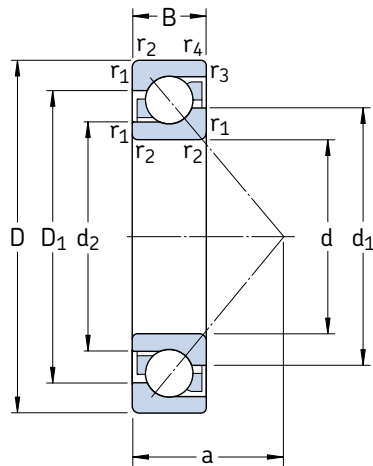

Principal dimensions			Basic load ratings		Fatigue load limit P_u	Speed ratings		Mass	Designations ¹⁾	
d	D	B	C	C_0		Refer- ence speed	Limiting speed		Universally matchable bearing	Basic design bearing
mm			kN		kN	r/min		kg	–	
70	125	24	75	64	2,7	6 300	6 300	1,10	* 7214 BECBP	–
	125	24	71,5	60	2,5	6 000	6 000	1,10	7214 BECBY	7214 BEP
	125	24	72	60	2,55	6 300	6 300	1,18	* 7214 BECBM	–
	150	35	127	98	3,9	5 600	5 600	2,55	* 7314 BECBP	–
	150	35	119	90	3,65	5 300	5 300	2,67	7314 BECBY	7314 BEP
	150	35	127	98	3,9	5 600	5 600	2,83	* 7314 BECBM	–
75	130	25	72,8	64	2,65	5 600	5 600	1,18	7215 BECBP	7215 BEP
	130	25	72,8	64	2,65	5 600	5 600	1,26	7215 BECBY	–
	130	25	70,2	60	2,5	5 600	6 000	1,29	7215 BECBM	–
	160	37	132	104	4,15	5 300	5 300	3,06	* 7315 BECBP	–
	160	37	125	98	3,8	5 000	5 000	3,06	–	7315 BEP
	160	37	133	106	4,15	5 000	5 000	3,20	7315 BECBY	–
80	140	26	85	75	3,05	5 600	5 600	1,43	* 7216 BECBP	–
	140	26	83,2	73,5	3	5 300	5 300	1,58	7216 BECBY	–
	140	26	85	75	3,05	5 600	5 600	1,59	* 7216 BECBM	–
	170	39	143	118	4,5	5 000	5 000	3,64	* 7316 BECBP	–
	170	39	135	110	4,15	4 500	4 500	3,64	–	7316 BEP
	170	39	143	118	4,5	4 500	4 500	3,70	7316 BECBY	7316 BEY
85	150	28	102	90	3,55	5 300	5 300	1,83	* 7217 BECBP	–
	150	28	95,6	83	3,25	5 000	5 000	1,83	7217 BECBY	7217 BEP
	150	28	95,6	83	3,25	5 000	5 300	1,99	7217 BECBM	–
	180	41	156	132	4,9	4 800	4 800	4,26	* 7317 BECBP	–
	180	41	146	112	4,5	4 300	4 300	4,26	–	7317 BEP
	180	41	153	132	4,9	4 300	4 300	4,59	7317 BECBY	–
	180	41	156	132	4,9	4 800	4 800	4,74	* 7317 BECBM	–
	180	41	146	112	4,5	4 300	4 500	4,74	–	7317 BEM

* SKF Explorer bearing

¹⁾ For available final variants → matrix 1 on page 419

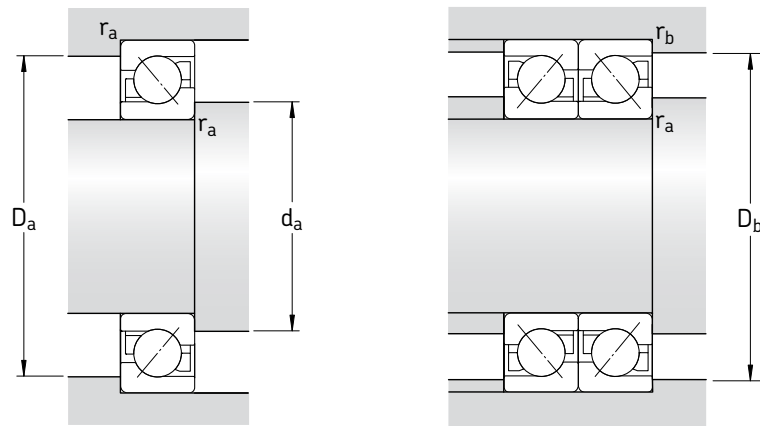

Dimensions

Abutment and fillet dimensions

d	$\underset{\sim}{d}_1$	$\underset{\sim}{d}_2$	$\underset{\sim}{D}_1$	$r_{1,2}$ min	$r_{3,4}$ min	a	d_a min	D_a max	D_b max	r_a max	r_b max
mm							mm				
70	91,5	80,3	104,8	1,5	1	53	79	116	119	1,5	1
	91,5	80,3	104,8	1,5	1	53	79	116	119	1,5	1
	91,5	80,3	104,8	1,5	1	53	79	116	119	1,5	1
	101,1	84,4	121	2,1	1,1	64	82	138	143	2	1
	101,1	84,4	121	2,1	1,1	64	82	138	143	2	1
	101,1	84,4	121	2,1	1,1	64	82	138	143	2	1
75	96,3	85,3	110,1	1,5	1	56	84	121	124	1,5	1
	96,3	85,3	110,1	1,5	1	56	84	121	124	1,5	1
	96,3	85,3	110,1	1,5	1	56	84	121	124	1,5	1
	108,3	91,1	128,7	2,1	1,1	68	87	148	153	2	1
	108,3	91,1	128,7	2,1	1,1	68	87	148	153	2	1
	108,3	91,1	128,7	2,1	1,1	68	87	148	153	2	1
80	103,6	91,4	117,9	2	1	59	91	129	134	2	1
	103,6	91,4	117,9	2	1	59	91	129	134	2	1
	103,6	91,4	117,9	2	1	59	91	129	134	2	1
	115,2	97,1	136,8	2,1	1,1	72	92	158	163	2	1
	115,2	97,1	136,8	2,1	1,1	72	92	158	163	2	1
	115,2	97,1	136,8	2,1	1,1	72	92	158	163	2	1
85	110,1	97	126,7	2	1	63	96	139	144	2	1
	110,1	97	126,7	2	1	63	96	139	144	2	1
	110,1	97	126,7	2	1	63	96	139	144	2	1
	122,3	103	145	3	1,1	76	99	166	173	2,5	1
	122,3	103	145	3	1,1	76	99	166	173	2,5	1
	122,3	103	145	3	1,1	76	99	166	173	2,5	1

Single row angular contact ball bearings
d 90 – 105 mm

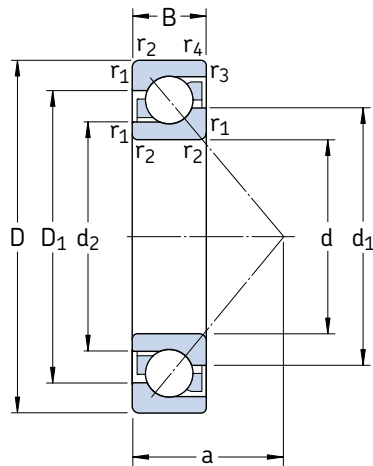

Principal dimensions			Basic load ratings		Fatigue load limit P_u	Speed ratings		Mass	Designations ¹⁾	
d	D	B	C	C_0		Refer- ence speed	Limiting speed		Universally matchable bearing	Basic design bearing
mm			kN		kN	r/min		kg	–	
90	160	30	116	104	4	4 800	4 800	2,12	* 7218 BECBP	–
	160	30	108	96,5	3,65	4 500	4 500	2,34	7218 BECBY	7218 BEP
	160	30	108	96,5	3,65	4 500	4 800	2,41	7218 BECBM	–
90	190	43	166	146	5,3	4 500	4 500	4,98	* 7318 BECBP	–
	190	43	156	134	4,8	4 000	4 000	4,98	–	7318 BEP
	190	43	165	146	5,2	4 000	4 000	5,22	7318 BECBY	–
	190	43	166	146	5,3	4 500	4 500	5,53	* 7318 BECBM	–
	190	43	156	134	4,8	4 000	4 300	5,53	–	7318 BEM
	190	43	156	134	4,8	4 000	4 300	5,53	–	7318 BEM
95	170	32	129	118	4,4	4 800	4 800	2,68	* 7219 BECBP	–
	170	32	124	108	4	4 300	4 300	2,68	–	7219 BEP
	170	32	124	108	4	4 300	4 300	2,82	7219 BECBY	–
95	170	32	129	118	4,4	4 800	4 800	2,95	* 7219 BECBM	–
	200	45	180	163	5,7	4 300	4 300	5,77	* 7319 BECBP	–
	200	45	168	150	5,2	3 800	3 800	5,77	–	7319 BEP
	200	45	178	163	5,6	3 800	3 800	6,17	7319 BECBY	–
	200	45	180	163	5,7	4 300	4 300	6,41	* 7319 BECBM	–
	200	45	168	150	5,2	3 800	4 000	6,41	–	7319 BEM
	200	45	168	150	5,2	3 800	4 000	6,41	–	7319 BEM
100	180	34	143	134	4,75	4 500	4 500	3,29	* 7220 BECBP	–
	180	34	135	122	4,4	4 000	4 000	3,29	–	7220 BEP
	180	34	135	122	4,4	4 000	4 000	3,38	7220 BECBY	7220 BEY
	180	34	135	122	4,4	4 000	4 300	3,61	7220 BECBM	–
100	215	47	216	208	6,95	4 000	4 000	7,17	* 7320 BECBP	–
	215	47	203	190	6,4	3 600	3 600	7,17	–	7320 BEP
	215	47	203	190	6,4	3 600	3 600	7,15	7320 BECBY	7320 BEY
	215	47	216	208	6,95	4 000	4 000	8,00	* 7320 BECBM	–
	215	47	203	190	6,4	3 600	3 800	8,00	–	7320 BEM
	215	47	203	190	6,4	3 600	3 800	8,00	–	7320 BEM
105	190	36	156	150	5,2	4 300	4 300	3,82	* 7221 BECBP	–
	190	36	148	137	4,8	3 800	4 000	4,18	7221 BECBM	–
105	225	49	228	228	7,5	3 800	3 800	8,46	* 7321 BECBP	–
	225	49	203	193	6,4	3 400	3 600	9,12	7321 BECBM	–

* SKF Explorer bearing

¹⁾ For available final variants → **matrix 1** on page 419

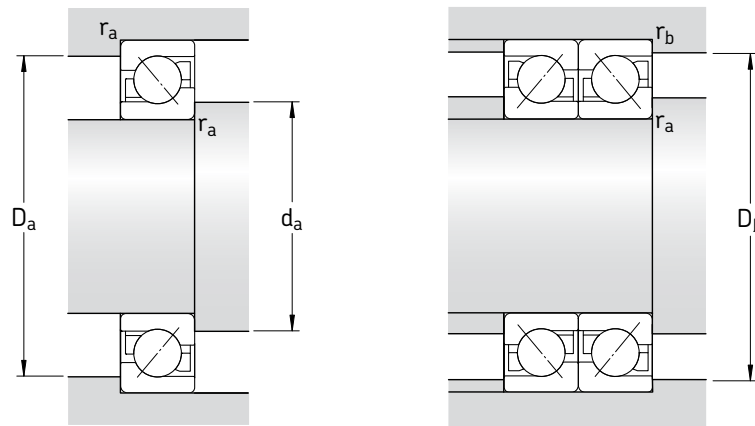

Dimensions

Abutment and fillet dimensions

d	\tilde{d}_1	\tilde{d}_2	\tilde{D}_1	$r_{1,2}$ min	$r_{3,4}$ min	a	d_a min	D_a max	D_b max	r_a max	r_b max
mm							mm				
90	117,1	103	134,8	2	1	67	101	149	154	2	1
	117,1	103	134,8	2	1	67	101	149	154	2	1
	117,1	103	134,8	2	1	67	101	149	154	2	1
	129,2	109	153,1	3	1,1	80	104	176	183	2,5	1
	129,2	109	153,1	3	1,1	80	104	176	183	2,5	1
	129,2	109	153,1	3	1,1	80	104	176	183	2,5	1
	129,2	109	153,1	3	1,1	80	104	176	183	2,5	1
95	124,3	109,1	142,5	2,1	1,1	72	107	158	163	2	1
	124,3	109,1	142,5	2,1	1,1	72	107	158	163	2	1
	124,3	109,1	142,5	2,1	1,1	72	107	158	163	2	1
	124,3	109,1	142,5	2,1	1,1	72	107	158	163	2	1
	136,2	114,9	161,3	3	1,1	84	109	186	193	2,5	1
	136,2	114,9	161,3	3	1,1	84	109	186	193	2,5	1
	136,2	114,9	161,3	3	1,1	84	109	186	193	2,5	1
100	131	115,2	150,9	2,1	1,1	76	112	168	173	2	1
	131	115,2	150,9	2,1	1,1	76	112	168	173	2	1
	131	115,2	150,9	2,1	1,1	76	112	168	173	2	1
	131	115,2	150,9	2,1	1,1	76	112	168	173	2	1
	144,5	120,5	173,4	3	1,1	90	114	201	-	2,5	-
	144,5	120,5	173,4	3	1,1	90	114	201	208	2,5	1
	144,5	120,5	173,4	3	1,1	90	114	201	208	2,5	1
105	138	121,2	159,1	2,1	1,1	80	117	178	183	2	1
	138	121,2	159,1	2,1	1,1	80	117	178	183	2	1
	151,7	127,9	181,4	3	1,1	94	119	211	218	2,5	1
	151,7	127,9	181,4	3	1,1	94	119	211	218	2,5	1
	144,5	120,5	173,4	3	1,1	90	114	201	-	2,5	-
	144,5	120,5	173,4	3	1,1	90	114	201	208	2,5	1
	144,5	120,5	173,4	3	1,1	90	114	201	208	2,5	1

Single row angular contact ball bearings
d 110 – 240 mm

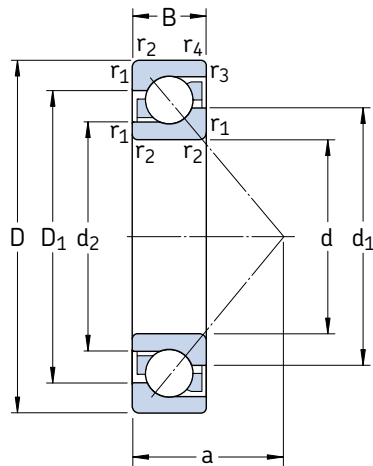

Principal dimensions			Basic load ratings		Fatigue load limit P_u	Speed ratings		Mass	Designations ¹⁾	
d	D	B	dynamic C	static C_0		Refer- ence speed	Limiting speed		Universally matchable bearing	Basic design bearing
mm			kN		kN	r/min		kg	–	
110	200	38	170	166	4,7	4 000	4 000	4,60	* 7222 BECBP	–
	200	38	163	153	5,2	3 600	3 600	4,75	7222 BECBY	–
	200	38	153	143	4,9	3 600	3 800	4,95	7222 BECBM	7222 BEM
	240	50	240	245	7,8	3 600	3 600	9,69	* 7322 BECBP	–
	240	50	225	224	7,2	3 200	3 200	9,69	7322 BECBY	7322 BEY
	240	50	225	224	7,2	3 200	3 400	10,7	7322 BECBM	7322 BEM
120	215	40	165	163	5,3	3 400	3 600	5,89	7224 BCBM	7224 BM
	260	55	238	250	7,65	3 000	3 200	13,8	7324 BCBM	–
130	230	40	186	193	6,1	3 200	3 400	6,76	7226 BCBM	7226 BM
	280	58	276	305	9	2 800	2 800	17,1	7326 BCBM	7326 BM
140	250	42	199	212	6,4	2 800	3 000	8,63	7228 BCBM	7228 BM
	300	62	302	345	9,8	2 600	2 600	21,3	7328 BCBM	–
150	270	45	216	240	6,95	2 600	2 800	10,8	7230 BCBM	–
	320	65	332	390	10,8	2 400	2 400	25,0	7330 BCBM	–
160	290	48	255	300	8,5	2 400	2 600	13,6	7232 BCBM	–
170	310	52	281	345	9,5	2 400	2 400	16,7	7234 BCBM	–
	360	72	390	490	12,7	2 000	2 200	34,6	7334 BCBM	–
180	320	52	291	375	10	2 200	2 400	17,6	7236 BCBM	–
	380	75	410	540	13,7	2 000	2 000	40,0	7336 BCBM	–
190	340	55	307	405	10,4	2 000	2 200	21,9	7238 BCBM	–
	400	78	442	600	14,6	1 900	1 900	48,3	7338 BCBM	–
200	360	58	325	430	11	1 800	2 000	25,0	7240 BCBM	–
	420	80	462	655	15,6	1 800	1 800	52,8	7340 BCBM	–
220	400	65	390	560	13,4	1 800	1 800	35,2	7244 BCBM	–
240	440	72	364	540	12,5	1 600	1 700	49,0	7248 BCBM	–

* SKF Explorer bearing

¹⁾ For available final variants → matrix 1 on page 419

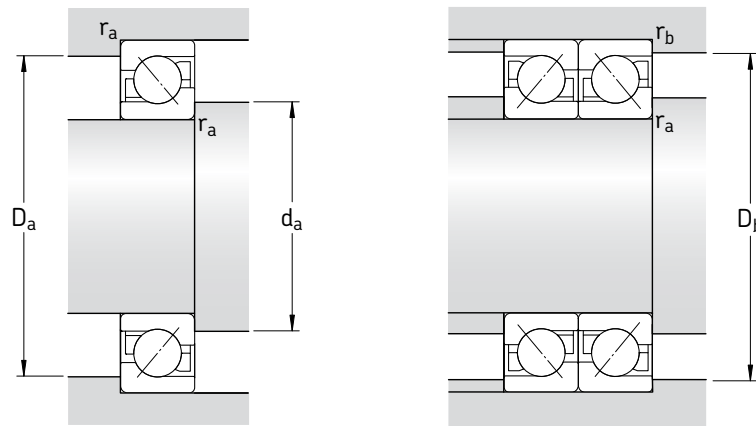

Dimensions

Abutment and fillet dimensions

d	d ₁ ~	d ₂ ~	D ₁ ~	r _{1,2} min	r _{3,4} min	a	d _a min	D _a max	D _b max	r _a max	r _b max
mm							mm				
110	144,9	127,1	167,4	2,1	1,1	84	122	188	193	2	1
	144,9	127,1	167,4	2,1	1,1	84	122	188	193	2	1
	144,9	127,1	167,4	2,1	1,1	84	122	188	193	2	1
120	160,8	135	193,5	3	1,1	99	124	226	233	2,5	1
	160,8	135	193,5	3	1,1	99	124	226	233	2,5	1
	160,8	135	193,5	3	1,1	99	124	226	233	2,5	1
130	157	138,6	179,4	2,1	1,1	90	132	203	208	2	1
	178,4	153,9	211	3	1,5	107	134	246	253	2,5	1
140	169	149,6	192,6	3	1,1	96	144	216	222	2,5	1
	189,9	161,4	227,5	4	1,5	115	147	263	271	3	1,5
150	183,3	163,6	209,5	3	1,1	103	154	236	243	2,5	1
	203	172,2	243	4	1,5	123	157	283	291	3	1,5
160	197,2	175,6	226	3	1,1	111	164	256	263	2,5	1
	216,1	183,9	258,7	4	1,5	131	167	303	311	3	1,5
170	211	187,6	242,3	3	1,1	118	174	276	283	2,5	1
180	227,4	202	261	4	1,5	127	187	293	301	3	1,5
	243,8	207,9	292	4	2	147	187	343	351	3	1,5
190	234,9	209,6	268,8	4	1,5	131	197	303	311	3	1,5
	257,7	219,8	308	4	2	156	197	363	369	3	2
200	250,4	224,1	285,4	4	1,5	139	207	323	331	3	1,5
	271,6	231,8	324,3	5	2	164	210	380	389	4	2
220	263,3	235,1	300,8	4	1,5	146	217	343	351	3	1,5
	287	247	339,5	5	2	170	220	400	409	4	2
240	291,1	259,1	333,4	4	1,5	164	237	383	391	3	1,5
240	322	292	361	4	1,5	180	257	423	431	3	1,5



Double row angular contact ball bearings

Designs	434
Basic design bearings	435
Sealed bearings	435
Bearings with a two-piece inner ring	436
SKF Explorer class bearings	437
Bearing data – general	437
Dimensions	437
Tolerances	437
Internal clearance	438
Misalignment	438
Influence of operating temperature on bearing material	438
Cages	438
Minimum load	439
Equivalent dynamic bearing load	440
Equivalent static bearing load	440
Supplementary designations	440
Product tables	442
Double row angular contact ball bearings	442
Sealed double row angular contact ball bearings	446

Designs

SKF double row angular contact ball bearings correspond in design to two single row angular contact ball bearings but take up less axial space. They can accommodate radial loads as well as axial loads acting in both directions. They provide stiff bearing arrangements and are able to accommodate tilting moments.

The SKF standard range of double row angular contact ball bearings (→ **fig. 1**) includes

- basic design bearings (**a**)
- sealed bearings (**b**)
- bearings with a two-piece inner ring (**c**).

The standard range is shown in **matrix 1** on **page 441**.

This bearing range covers sizes from 10 to 110 mm bore diameter. For information about other double row angular contact ball bearings, please refer to the “SKF Interactive Engineering Catalogue” on CD-ROM or online at www.skf.com.

Bearings in the 52 A and 53 A series

Basic design bearings in the 32 A and 33 A series shown in the product table as well as the corresponding sealed bearings to 2Z and 2RS1 design are identical to the corresponding bearings in the 52 and 53 series for the North American market. They have the same performance characteristics and dimensional features (except for the width of size 5200). However, the sealed bearings are filled with a different grease. Bearings in the 52 and 53 series use a mineral oil based high-temperature grease with polyurea thickener. The operating temperature range of this grease is -30 to $+140$ °C. The base oil viscosity is 115 mm²/s at 40 °C and 12 mm²/s at 100 °C.

Fig. 1

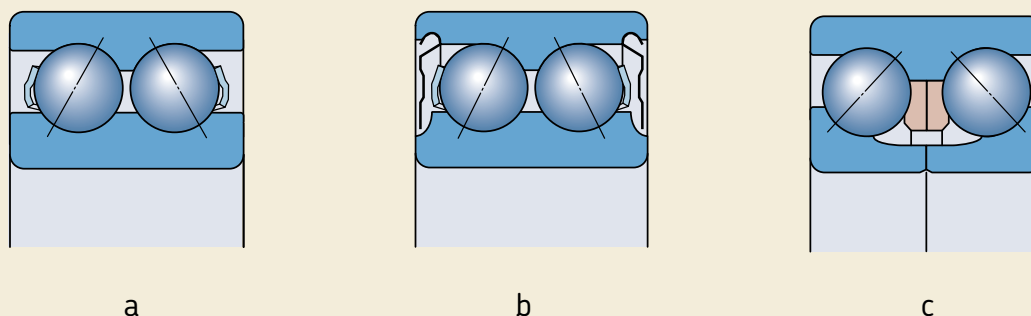

Basic design bearings

SKF double row angular contact ball bearings in the 32 A and 33 A series have optimized internal geometry and do not have filling slots. The advantages are

- universal applicability
- high radial and axial load carrying capacity in both directions
- quiet operation.

The bearings have a 30° contact angle and the ball sets are in a back-to-back arrangement.

Standard design bearings that are also available with seals or shields may, for manufacturing reasons, have seal recesses on inner and outer rings (→ **fig. 2**).

Sealed bearings

The most common basic design bearings can also be supplied with shields or seals (→ **matrix 1** on **page 441**). Bearings in the 32 A and 33 A series are filled with a high-quality NLGI class 3 grease with a lithium thickener and are marked with the designation suffix MT33. This grease has good corrosion inhibiting properties and has a temperature range of -30 to +120 °C. The base oil viscosity is 98 mm²/s at 40 °C and 9,4 mm²/s at 100 °C. Regarding the grease fill of bearings in the 52 A and 53 A series please refer to **page 434**.

Sealed bearings are lubricated for life and are maintenance-free. They should therefore not be washed or heated above 80 °C before mounting.

Bearings with shields

Bearings with shields, designation suffix 2Z, are produced in two different designs (→ **fig. 3**). The sheet steel shields used in smaller bearings form a narrow gap with the land of the inner ring shoulder (**a**). Larger bearings as well as all SKF Explorer bearings have recesses in the inner ring side faces into which the shields extend (**b**).

Shielded bearings are primarily intended for applications where the inner ring rotates. If the outer ring rotates there is a risk that grease will be lost from the bearing once it reaches a certain speed.

Fig. 2



Fig. 3



a



b

Double row angular contact ball bearings

Bearings with seals

Bearings with seals, designation suffix 2RS1, use a acrylonitrile-butadiene rubber, sheet steel reinforced seal that fits against a recess in the inner ring side face (→ **fig. 4**). The lip of the seal exerts a light pressure against the inner ring for a positive seal. The periphery of the seal engages in a recess in the outer ring to provide a good sealing. The permissible operating temperature range for these seals is -40 to $+100$ °C and up to $+120$ °C for brief periods.

Grease may be lost from sealed bearings at the inner ring under extreme operating conditions, e.g. at high speeds or at high temperatures. For applications where this could be a disadvantage, special design steps should be taken to prevent this. For additional information please contact the SKF application engineering service.

Bearings with a two-piece inner ring

In addition to the basic design bearings, double row angular contact ball bearings are also available with a two-piece inner ring (→ **fig. 5**). These bearings incorporate a large number of large balls and have a high load carrying capacity, especially in the axial direction.

Bearings in the 33 D series

Bearings in the 33 D series (**a**) have a 45° contact angle, a special internal clearance and can support heavy axial loads in both directions. The bearings are separable, i.e. the outer ring with ball and cage assemblies can be mounted independently of the inner ring halves.

Bearings in the 33 DNRCBM series

Bearings in the 33 DNRCBM series (**b**) have a 40° contact angle and a snap ring groove with snap ring in the outer ring, enabling simple and space-saving axial location in the housing. They have been designed specifically to operate under the conditions pertaining in centrifugal pumps, but can also be used in other applications. These bearings are non-separable.

Fig. 4



Fig. 5

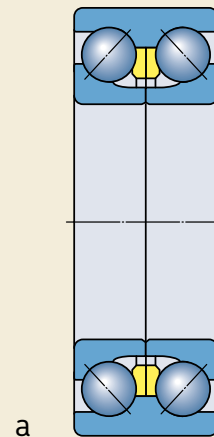

a

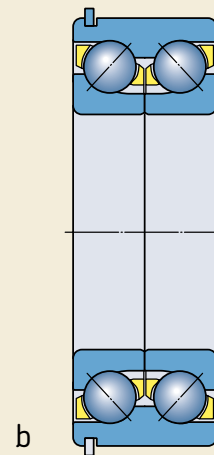

b

SKF Explorer class bearings

High performance SKF Explorer angular contact ball bearings are shown with an asterisk in the product tables. SKF Explorer bearings retain the designation of the earlier standard bearings, e.g. 3208 ATN9. However, each bearing and its box are marked with the name “EXPLORER”.

Bearing data – general

Dimensions

The boundary dimensions of SKF double row angular contact ball bearings are in accordance with ISO 15:1998, except for the width of bearing 3200 A.

The dimensions of the snap ring grooves and snap rings for bearings in the 33 DNRCBM series are listed in **table 1**. The dimensions of the snap ring grooves and snap rings conform to ISO 464:1995.

Tolerances

SKF basic design double row angular contact ball bearings are produced to Normal tolerances as standard. SKF Explorer bearings as well as bearings in the 33 DNRCBM series are produced to tolerance class P6 specifications.

The values for tolerances correspond to ISO 492:2002 and can be found in **tables 3** and **4** on **pages 125** and **126**.

Table 1

Dimensions of snap ring grooves and snap rings

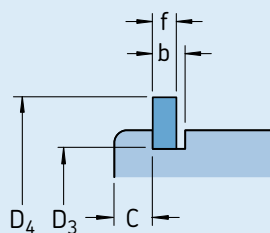

Bearing Designation	Dimensions					Snap ring Designation
	C	b	f	D ₃	D ₄	
–	mm					–
3308 DNRCBM	3,28	2,7	2,46	86,8	96,5	SP 90
3309 DNRCBM	3,28	2,7	2,46	96,8	106,5	SP 100
3310 DNRCBM	3,28	2,7	2,46	106,8	116,6	SP 110
3311 DNRCBM	4,06	3,4	2,82	115,2	129,7	SP 120
3313 DNRCBM	4,06	3,4	2,82	135,2	149,7	SP 140

Double row angular contact ball bearings

Internal clearance

SKF double row angular contact ball bearings in the 32 A and 33 A series are produced as standard with Normal axial internal clearance. They are also available with the greater C3 clearance (→ **matrix 1** on **page 441**). For bearings with smaller C2 clearance, please check availability before ordering.

Bearings in the 33 D and 33 DNRCBM series are produced exclusively with an axial internal clearance according to the values provided in **table 2**. They are valid for bearings before mounting under zero measuring loads.

Misalignment

Misalignment of the outer ring with respect to the inner ring of double row angular contact ball bearings can only be accommodated by generating forces between the balls and the raceways. Any misalignment will lead to increased noise in operation and reduced bearing service life.

Influence of operating temperature on bearing material

SKF angular contact ball bearings undergo a special heat treatment. When equipped with a steel or brass cage, they can operate at temperatures of up to +150 °C.

Cages

Depending on the bearing series, size and design, SKF double row angular contact ball bearings are fitted as standard with two of each of the following cages (→ **fig. 6**)

- an injection moulded snap-type cage of glass fibre reinforced polyamide 6,6, ball centred, designation suffix TN9 (**a**)
- a pressed snap-type steel cage, ball centred, no designation suffix or suffix J1 (**b**)
- a pressed steel crown cage, ball centred, no designation suffix (**c**)
- a pronged machined brass cage, outer ring centred, designation suffix MA (**d**)

Table 2

Axial internal clearance of double row angular contact ball bearings

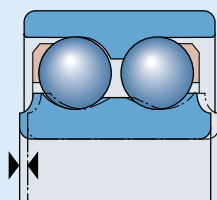

Bore diameter		Axial internal clearance of bearings in series						33 D		33 DNRCBM	
d over	incl.	C2		Normal		C3		min	max	min	max
		min	max	min	max	min	max				
mm		µm						µm		µm	
–	10	1	11	5	21	12	28	–	–	–	–
10	18	1	12	6	23	13	31	–	–	–	–
18	24	2	14	7	25	16	34	–	–	–	–
24	30	2	15	8	27	18	37	–	–	–	–
30	40	2	16	9	29	21	40	33	54	10	30
40	50	2	18	11	33	23	44	36	58	10	30
50	65	3	22	13	36	26	48	40	63	18	38
65	80	3	24	15	40	30	54	46	71	18	38
80	100	3	26	18	46	35	63	55	83	–	–
100	110	4	30	22	53	42	73	65	96	–	–

- a machined window-type brass cage, ball centred, designation suffix M (e).

Several bearings are available as standard with a choice of cage design so that bearings with a cage appropriate to the operating conditions can be chosen (→ **matrix 1** on **page 441**).

Note

Bearings with polyamide 6,6 cages can be operated at temperatures up to +120 °C. The lubricants generally used for rolling bearings do not have a detrimental effect on cage properties, with the exception of a few synthetic oils and greases with a synthetic oil base, and lubricants containing a high proportion of EP additives when used at high temperatures.

For detailed information about the temperature resistance and the applicability of cages, please refer to the section “Cage materials”, starting on **page 140**.

Minimum load

In order to provide satisfactory operation, double row angular contact ball bearings, like all ball and roller bearings, must always be subjected to a given minimum load, particularly if they are to operate at high speeds or are subjected to high accelerations or rapid changes in the direction of load. Under such conditions, the inertia forces of the balls and cages, and the friction in the lubricant, can have a detrimental influence on the rolling conditions in the bearing arrangement

and may cause damaging sliding movements to occur between the balls and raceways.

The requisite minimum radial load to be applied to double row angular contact ball bearings can be estimated using

$$F_{rm} = k_r \left(\frac{v n}{1\,000} \right)^{2/3} \left(\frac{d_m}{100} \right)^2$$

where

F_{rm} = minimum radial load, kN

k_r = minimum radial load factor

0,06 for bearings in the 32 A series

0,07 for bearings in the 33 A series

0,095 for bearings in the 33 D and

33 DNR series

v = oil viscosity at operating temperature, mm²/s

n = rotational speed, r/min

d_m = bearing mean diameter
= 0,5 (d + D), mm

When starting up at low temperatures or when the lubricant is highly viscous, even greater minimum loads may be required. The weight of the components supported by the bearing, together with external forces, generally exceed the requisite minimum load. If this is not the case, the double row angular contact ball bearing must be subjected to an additional radial load.

Fig. 6

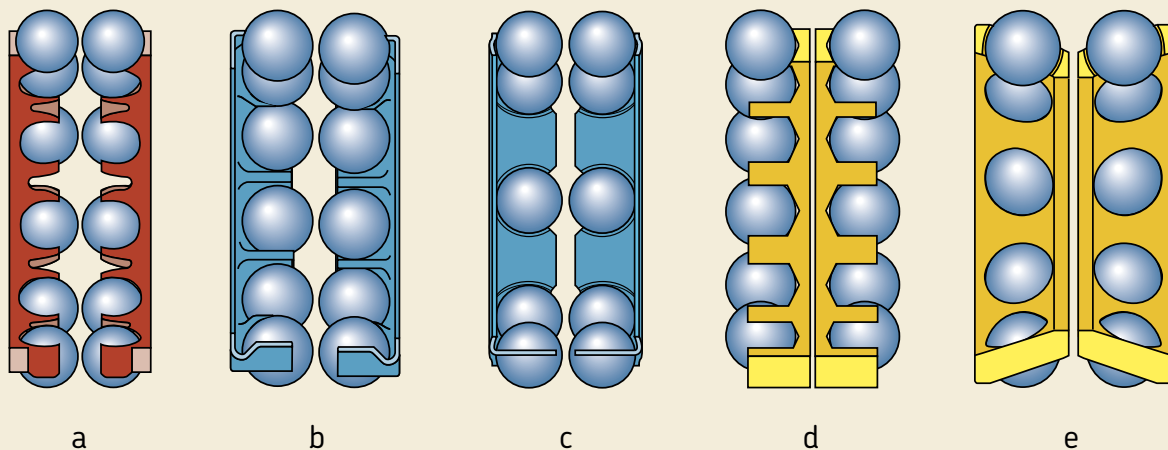

Double row angular contact ball bearings

Equivalent dynamic bearing load

$$P = F_r + Y_1 F_a \quad \text{when } F_a/F_r \leq e$$

$$P = X F_r + Y_2 F_a \quad \text{when } F_a/F_r > e$$

The values for the factors e , X , Y_1 and Y_2 depend on the bearing contact angle and are listed in **table 3**.

Equivalent static bearing load

$$P_0 = F_r + Y_0 F_a$$

The value for the factor Y_0 depends on the bearing contact angle and is provided in **table 3**.

Supplementary designations

The designation suffixes used to identify certain features of SKF double row angular contact ball bearings are explained in the following.

- A** No filling slots
- CB** Controlled axial internal clearance
- C2** Axial internal clearance smaller than Normal
- C3** Axial internal clearance greater than Normal
- D** Two-piece inner ring
- J1** Pressed snap-type steel cage, ball centred
- M** Machined window-type brass cage, ball centred
- MA** Pronged machined brass cage, outer ring centred
- MT33** Grease with lithium thickener of consistency 3 to the NLGI Scale for a temperature range -30 to $+120$ °C (normal fill grade)
- N** Snap ring groove in the outer ring
- NR** Snap ring groove in the outer ring, with snap ring
- P5** Dimensional and running accuracy to ISO tolerance class 5
- P6** Dimensional and running accuracy to ISO tolerance class 6
- P62** P6 + C2
- P63** P6 + C3
- 2RS1** Sheet steel reinforced contact seal of acrylonitrile-butadiene rubber (NBR) on both sides of the bearing
- TN9** Injection moulded snap-type cage of glass fibre reinforced polyamide 6,6, ball centred
- W64** Solid Oil filling
- ZZ** Shield of pressed sheet steel on both sides of the bearing

Table 3

Bearing series	Calculation factors				
	e	X	Y_1	Y_2	Y_0
32 A (52 A)	0,8	0,63	0,78	1,24	0,66
33 A (53 A)	0,8	0,63	0,78	1,24	0,66
33 D	1,34	0,54	0,47	0,81	0,44
33 DNRCBM	1,14	0,57	0,55	0,93	0,52

SKF double row angular contact ball bearings – standard assortment

Bore diameter, mm	Basic design bearings				Bearings with shields				Bearings with seals				Bearings with a two-piece inner ring				Bearing size										
	32 A	32 A/C3	32 ATN9	32 ATN9/C3	33 A	33 A/C3	33 ATN9	33 ATN9/C3	32 A-2Z/MT33	32 A-2Z/C3MT33	32 A-2ZTN9/MT33	32 A-2ZTN9/C3MT33	33 A-2Z/MT33	33 A-2Z/C3MT33	33 A-2Z/C3MT33	33 A-2ZTN9/C3MT33		32 A-2RS1/MT33	32 A-2RS1TN9/MT33	33 A-2RS1/MT33	33 A-2RS1TN9/MT33	33 DJ1	33 DTN9	33 DMA	33 DNRCBM		
10																										00	
12																											01
15																											02
17																											03
20																											04
25																											05
30																											06
35																											07
40																											08
45																											09
50																											10
55																											11
60																											12
65																											13
70																											14
75																											15
80																											16
85																											17
90																											18
95																											19
100																											20
110																											22

SKF Explorer bearings
 Other SKF standard bearings

Bearings in the 52 A and 53 A series

This matrix is also valid for bearings in the 52 A and 53 A series, which are identical to the corresponding bearings in the 32 A and 33 A series. However, sealed bearings in the 52 A and 53 A series are filled with a high-temperature grease (→ page 434). They do not carry any designation suffix for the grease.

Bearings above 110 mm bore

Please consult the "SKF Interactive Engineering Catalogue" on CD-ROM or online at www.skf.com.

Double row angular contact ball bearings d 10 – 50 mm

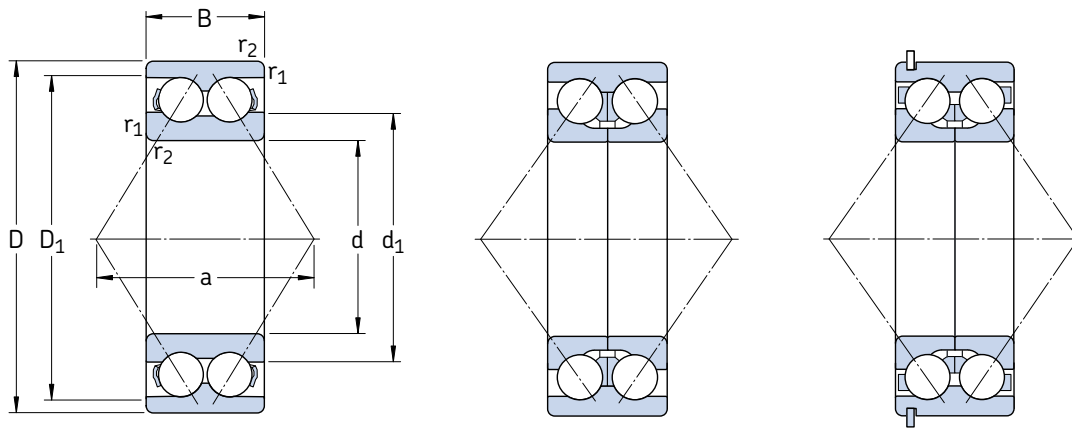

A design

33 D

33 DNRCBM¹⁾

Principal dimensions			Basic load ratings		Fatigue load limit P_u	Speed ratings		Mass	Designations ²⁾	
d	D	B	C	C_0		Refer- ence speed	Limiting speed		Bearing with metal cage	polyamide cage
mm			kN		kN	r/min		kg	–	
10	30	14	7,61	4,3	0,183	22 000	24 000	0,051	–	3200 ATN9
12	32	15,9	10,1	5,6	0,24	20 000	22 000	0,058	–	3201 ATN9
15	35	15,9	11,2	6,8	0,285	17 000	18 000	0,066	–	3202 ATN9
	42	19	15,1	9,3	0,4	15 000	16 000	0,13	–	3302 ATN9
17	40	17,5	14,3	8,8	0,365	15 000	16 000	0,096	–	3203 ATN9
	47	22,2	21,6	12,7	0,54	14 000	14 000	0,18	–	3303 ATN9
20	47	20,6	20	12	0,51	14 000	14 000	0,16	* 3204 A	* 3204 ATN9
	52	22,2	23,6	14,6	0,62	13 000	13 000	0,22	* 3304 A	* 3304 ATN9
25	52	20,6	21,6	14,3	0,6	12 000	12 000	0,18	* 3205 A	* 3205 ATN9
	62	25,4	32	20,4	0,865	11 000	11 000	0,35	* 3305 A	* 3305 ATN9
30	62	23,8	30	20,4	0,865	10 000	10 000	0,29	* 3206 A	* 3206 ATN9
	72	30,2	41,5	27,5	1,16	9 000	9 000	0,53	* 3306 A	* 3306 ATN9
35	72	27	40	28	1,18	9 000	9 000	0,44	* 3207 A	* 3207 ATN9
	80	34,9	52	35,5	1,5	8 500	8 500	0,71	* 3307 A	* 3307 ATN9
	80	34,9	52,7	41,5	1,76	7 500	8 000	0,79	3307 DJ1	–
40	80	30,2	47,5	34	1,43	8 000	8 000	0,58	* 3208 A	* 3208 ATN9
	90	36,5	64	44	1,86	7 500	7 500	1,05	* 3308 A	* 3308 ATN9
	90	36,5	49,4	41,5	1,76	6 700	7 000	1,20	3308 DNRCBM	–
	90	36,5	68,9	64	2,45	6 700	7 000	1,05	3308 DMA	3308 DTN9
45	85	30,2	51	39	1,63	7 500	7 500	0,63	* 3209 A	* 3209 ATN9
	100	39,7	75	53	2,24	6 700	6 700	1,40	* 3309 A	* 3309 ATN9
	100	39,7	61,8	52	2,2	6 000	6 300	1,50	3309 DNRCBM	–
	100	39,7	79,3	69,5	3	6 000	6 300	1,60	3309 DMA	–
50	90	30,2	51	39	1,66	7 000	7 000	0,66	* 3210 A	* 3210 ATN9
	110	44,4	90	64	2,75	6 000	6 000	1,95	* 3310 A	* 3310 ATN9
	110	44,4	81,9	69,5	3	5 300	5 600	1,95	3310 DNRCBM	–
	110	44,4	93,6	85	3,6	5 300	5 600	2,15	3310 DMA	–

* SKF Explorer bearing

¹⁾ For dimensions of snap ring groove and snap ring → **table 1** on page 437

²⁾ For available final variants → **matrix 1** on page 441

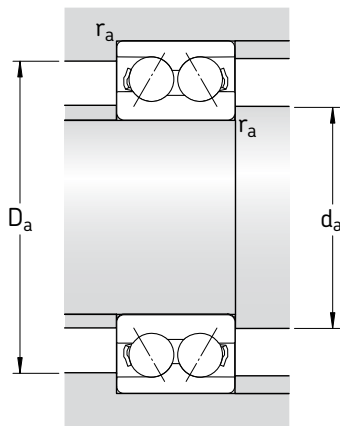

Dimensions					Abutment and fillet dimensions		
d	d ₁ ~	D ₁ ~	r _{1,2} min	a	d _a min	D _a max	r _a max
mm					mm		
10	17,7	23,6	0,6	16	14,4	25,6	0,6
12	19,1	26,5	0,6	19	16,4	27,6	0,6
15	22,1	29,5	0,6	21	19,4	30,6	0,6
	25,4	34,3	1	24	20,6	36,4	1
17	25,1	33,6	0,6	23	21,4	35,6	0,6
	27,3	38,8	1	28	22,6	41,4	1
20	27,7	40,9	1	28	25,6	41,4	1
	29,9	44,0	1,1	30	27	45	1
25	32,7	45,9	1	30	30,6	46,4	1
	35,7	53,4	1,1	36	32	55	1
30	38,7	55,2	1	36	35,6	56,4	1
	39,8	64,1	1,1	42	37	65	1
35	45,4	63,9	1,1	42	42	65	1
	44,6	70,5	1,5	47	44	71	1,5
	52,8	69,0	1,5	76	44	71	1,5
40	47,8	72,1	1,1	46	47	73	1
	50,8	80,5	1,5	53	49	81	1,5
	60,1	79,5	1,5	71	49	81	1,5
	59,4	80,3	1,5	84	49	81	1,5
45	52,8	77,1	1,1	49	52	78	1
	55,6	90	1,5	58	54	91	1,5
	68	87,1	1,5	79	54	91	1,5
	70	86,4	1,5	93	54	91	1,5
50	57,8	82,1	1,1	52	57	83	1
	62	99,5	2	65	61	99,5	2
	74,6	87	2	88	61	99	2
	76,5	94,2	2	102	61	99	2

Double row angular contact ball bearings

d 55 – 110 mm

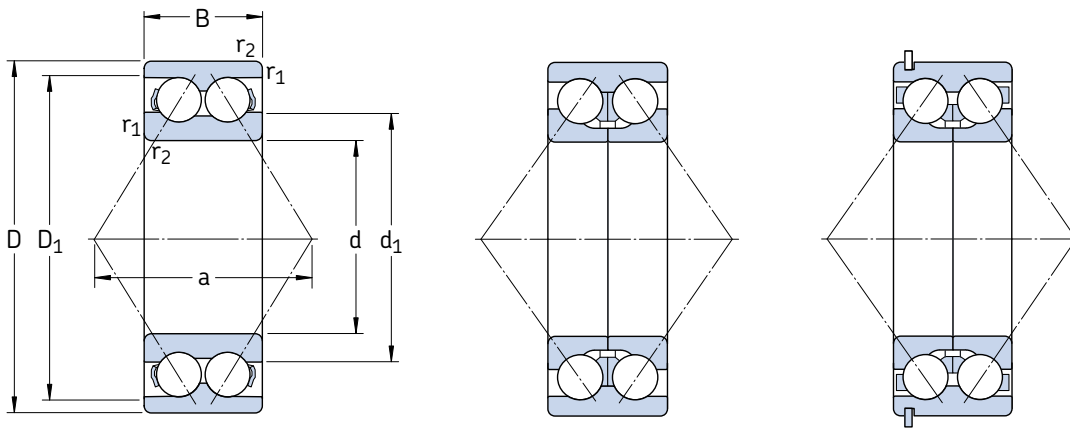

A design

33 D

33 DNRCBM¹⁾

Principal dimensions			Basic load ratings		Fatigue load limit P_u	Speed ratings		Mass	Designations ²⁾	
d	D	B	C	C_0		Refer- ence speed	Limiting speed		Bearing with metal cage	polyamide cage
mm			kN		kN	r/min		kg	–	
55	100	33,3	60	47,5	2	6 300	6 300	1,05	* 3211 A	* 3211 ATN9
	120	49,2	112	81,5	3,45	5 300	5 300	2,55	* 3311 A	* 3311 ATN9
	120	49,2	95,6	83	3,55	4 800	5 000	2,55	3311 DNRCBM	–
	120	49,2	111	100	4,3	4 800	5 000	2,80	3311 DMA	–
60	110	36,5	73,5	58,5	2,5	5 600	5 600	1,40	* 3212 A	* 3212 ATN9
	130	54	127	95	4,05	5 000	5 000	3,25	* 3312 A	–
65	120	38,1	80,6	73,5	3,1	4 500	4 800	1,75	3213 A	–
	140	58,7	146	110	4,55	4 500	4 500	4,10	* 3313 A	–
	140	58,7	138	122	5,1	4 300	4 500	4,00	3313 DNRCBM	–
70	125	39,7	88,4	80	3,4	4 300	4 500	1,90	3214 A	–
	150	63,5	163	125	5	4 300	4 300	5,05	* 3314 A	–
75	130	41,3	95,6	88	3,75	4 300	4 500	2,10	3215 A	–
	160	68,3	176	140	5,5	4 000	4 000	5,55	* 3315 A	–
80	140	44,4	106	95	3,9	4 000	4 300	2,65	3216 A	–
	170	68,3	182	156	6	3 400	3 600	6,80	3316 A	–
	170	68,3	190	196	7,35	3 400	3 600	7,55	3316 DMA	–
85	150	49,2	124	110	4,4	3 600	3 800	3,40	3217 A	–
	180	73	195	176	6,55	3 200	3 400	8,30	3317 A	–
90	160	52,4	130	120	4,55	3 400	3 600	4,15	3218 A	–
	190	73	195	180	6,4	3 000	3 200	9,25	3318 A	–
	190	73	225	250	8,8	3 000	3 200	10,0	3318 DMA	–
95	170	55,6	159	146	5,4	3 200	3 400	5,00	3219 A	–
	200	77,8	225	216	7,5	2 800	3 000	11,0	3319 A	–
	200	77,8	242	275	9,5	2 800	3 000	12,0	3319 DMA	–
100	180	60,3	178	166	6	3 000	3 200	6,10	3220 A	–
	215	82,6	255	255	8,65	2 600	2 800	13,5	3320 A	–
110	200	69,8	212	212	7,2	2 800	2 800	8,80	3222 A	–
	240	92,1	291	305	9,8	2 400	2 600	19,0	3322 A	–

* SKF Explorer bearing

¹⁾ For dimensions of snap ring groove and snap ring → table 1 on page 437

²⁾ For available final variants → matrix 1 on page 441

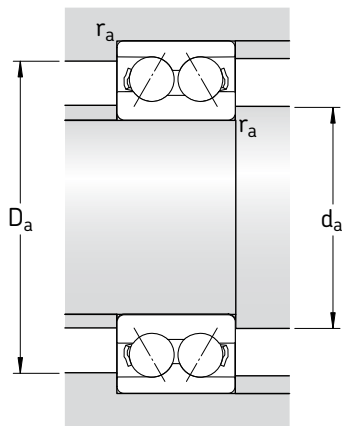

Dimensions					Abutment and fillet dimensions		
d	d_1 ~	D_1 ~	$r_{1,2}$ min	a	d_a min	D_a max	r_a max
mm					mm		
55	63,2	92,3	1,5	57	63	91	1,5
	68,4	109	2	72	66	109	2
	81,6	106,5	2	97	66	109	2
	81,3	104,4	2	114	66	109	2
60	68,8	101	1,5	63	69	101	1,5
	74,3	118	2,1	78	72	118	2
65	85	103	1,5	71	74	111	1,5
	78,5	130	2,1	84	77	130	2
	95,1	126	2,1	114	77	128	2
70	88,5	107	1,5	74	79	116	1,5
	84,2	139	2,1	89	82	138	2
75	91,9	112	1,5	77	84	121	1,5
	88,8	147	2,1	97	87	148	2
80	97,7	120	2	82	91	129	2
	108	143	2,1	101	92	158	2
	114	145	2,1	158	92	158	2
85	104	128	2	88	96	139	2
	116	153	3	107	99	166	2,5
90	111	139	2	94	101	149	2
	123	160	3	112	104	176	2,5
	130	167	3	178	104	176	2,5
95	119	147	2,1	101	107	158	2
	127	168	3	118	109	186	2,5
	138	177	3	189	109	186	2,5
100	125	155	2,1	107	112	168	2
	136	180	3	127	114	201	2,5
110	139	173	2,1	119	122	188	2
	153	200	3	142	124	226	2,5

Sealed double row angular contact ball bearings

d 10 – 60 mm

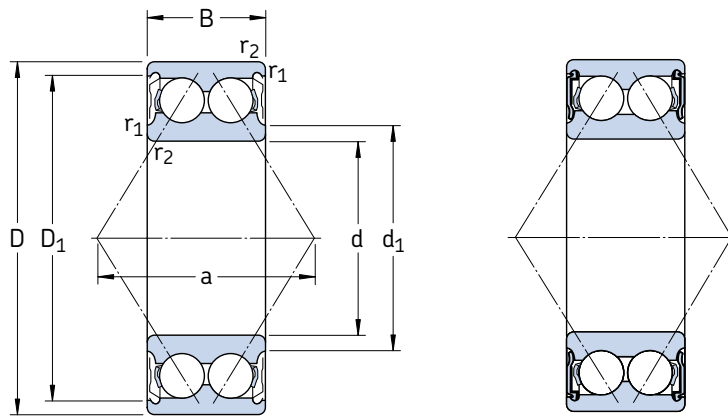

2Z

2RS1

Principal dimensions			Basic load ratings		Fatigue load limit P_u	Limiting speeds		Mass	Designations ¹⁾	
d	D	B	C	C_0		Bearing with shields	seals		Bearing with shields	seals
mm			kN		kN	r/min		kg	–	
10	30	14	7,61	4,3	0,183	24 000	17 000	0,051	3200 A-2Z	3200 A-2RS1
12	32	15,9	10,1	5,6	0,24	22 000	15 000	0,058	3201 A-2Z	3201 A-2RS1
15	35	15,9	11,2	6,8	0,285	18 000	14 000	0,066	3202 A-2Z	3202 A-2RS1
	42	19	15,1	9,3	0,4	16 000	12 000	0,13	3302 A-2Z	3302 A-2RS1
17	40	17,5	14,3	8,8	0,365	16 000	12 000	0,10	3203 A-2Z	3203 A-2RS1
	47	22,2	21,6	12,7	0,54	14 000	11 000	0,18	3303 A-2Z	3303 A-2RS1
20	47	20,6	20	12	0,51	14 000	10 000	0,16	* 3204 A-2Z	* 3204 A-2RS1
	52	22,2	23,6	14,6	0,62	13 000	9 000	0,22	* 3304 A-2Z	* 3304 A-2RS1
25	52	20,6	21,6	14,3	0,6	12 000	8 500	0,18	* 3205 A-2Z	* 3205 A-2RS1
	62	25,4	32	20,4	0,865	11 000	7 500	0,35	* 3305 A-2Z	* 3305 A-2RS1
30	62	23,8	30	20,4	0,865	10 000	7 500	0,29	* 3206 A-2Z	* 3206 A-2RS1
	72	30,2	41,5	27,5	1,16	9 000	6 300	0,52	* 3306 A-2Z	* 3306 A-2RS1
35	72	27	40	28	1,18	9 000	6 300	0,44	* 3207 A-2Z	* 3207 A-2RS1
	80	34,9	52	35,5	1,5	8 500	6 000	0,73	* 3307 A-2Z	* 3307 A-2RS1
40	80	30,2	47,5	34	1,43	8 000	5 600	0,57	* 3208 A-2Z	* 3208 A-2RS1
	90	36,5	64	44	1,86	7 500	5 000	0,93	* 3308 A-2Z	* 3308 A-2RS1
45	85	30,2	51	39	1,63	7 500	5 300	0,63	* 3209 A-2Z	* 3209 A-2RS1
	100	39,7	75	53	2,24	6 700	4 800	1,25	* 3309 A-2Z	* 3309 A-2RS1
50	90	30,2	51	39	1,66	7 000	4 800	0,65	* 3210 A-2Z	* 3210 A-2RS1
	110	44,4	90	64	2,75	6 000	4 300	1,70	* 3310 A-2Z	* 3310 A-2RS1
55	100	33,3	60	47,5	2	6 300	4 500	0,91	* 3211 A-2Z	* 3211 A-2RS1
	120	49,2	112	81,5	3,45	5 300	3 800	2,65	* 3311 A-2Z	* 3311 A-2RS1
60	110	36,5	73,5	58,5	2,5	5 600	4 000	1,20	* 3212 A-2Z	* 3212 A-2RS1
	130	54	127	95	4,05	5 000	–	2,80	* 3312 A-2Z	–

* SKF Explorer bearing

¹⁾ For available final variants → matrix 1 on page 441

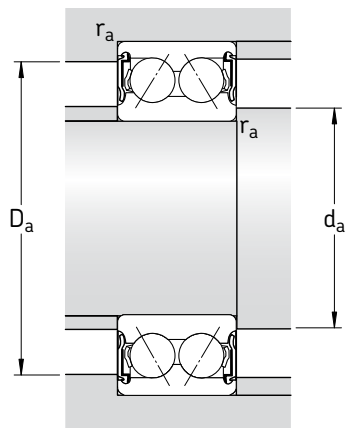

Dimensions					Abutment and fillet dimensions			
d	d_1 ~	D_1 ~	$r_{1,2}$ min	a	d_a min	d_a max	D_a max	r_a max
mm					mm			
10	15,8	25	0,6	16	14,4	15,5	25,6	0,6
12	17,2	27,7	0,6	19	16,4	17	27,7	0,6
15	20,2 23,7	30,7 35,7	0,6 1	21 24	19,4 20,6	20 23,5	30,7 36,4	0,6 1
17	23,3 25,7	35 40,2	0,6 1	23 28	21,4 22,6	23 25,5	35,6 41,4	0,6 1
20	27,7 29,9	40,9 44	1 1,1	28 30	25,6 27	27,5 29,5	41,4 45	1 1
25	32,7 35,7	45,9 53,4	1 1,1	30 36	30,6 32	32,5 35,5	46,4 55	1 1
30	38,7 39,8	55,2 64,1	1 1,1	36 42	35,6 37	38,5 39,5	56,4 65	1 1
35	45,4 44,6	63,9 70,5	1,1 1,5	42 47	42 44	45 44,5	65 71	1 1,5
40	47,8 50,8	72,1 80,5	1,1 1,5	46 53	47 49	47 50,5	73 81	1 1,5
45	52,8 55,6	77,1 90	1,1 1,5	49 58	52 54	52,5 55,5	78 91	1 1,5
50	57,8 62	82,1 99,5	1,1 2	52 65	57 61	57,5 61,5	83 99,5	1 2
55	63,2 68,4	92,3 109	1,5 2	57 72	63 66	63 68	91 109	1,5 2
60	68,8 73,4	101 118	1,5 2,1	63 78	68,5 72	68,5 73	101 118	1,5 2

Sealed double row angular contact ball bearings
d 65 – 75 mm

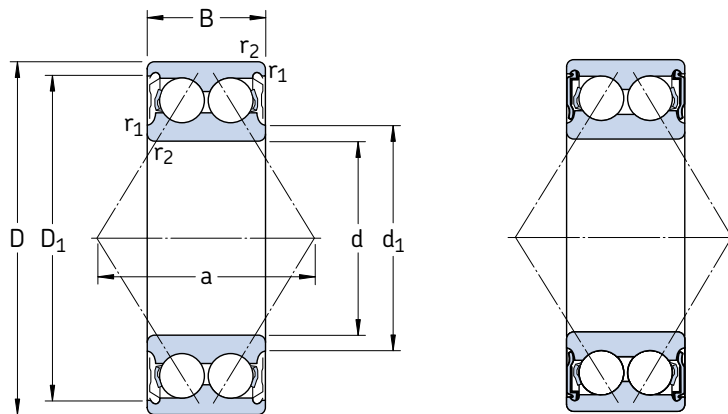

2Z

2RS1

Principal dimensions			Basic load ratings		Fatigue load limit P_u	Limiting speeds		Mass	Designations ¹⁾	
d	D	B	dynamic C	static C_0		Bearing with shields	seals		Bearing with shields	seals
mm			kN		kN	r/min		kg	–	
65	120	38,1	80,6	73,5	3,1	4 800	3 600	1,75	3213 A-2Z	3213 A-2RS1
	140	58,7	146	110	4,55	4 500	–	4,10	* 3313 A-2Z	–
70	125	39,7	88,4	80	3,4	4 500	–	1,90	3214 A-2Z	–
	150	63,5	163	125	5	4 300	–	5,05	* 3314 A-2Z	–
75	130	41,3	95,6	88	3,75	4 500	–	2,10	3215 A-2Z	–
	160	68,3	176	140	5,5	4 000	–	5,60	* 3315 A-2Z	–

* SKF Explorer bearing

¹⁾ For available final variants → matrix 1 on page 441

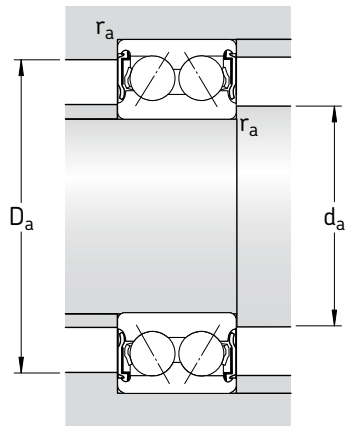

Dimensions					Abutment and fillet dimensions			
d	d ₁ ~	D ₁ ~	r _{1,2} min	a	d _a min	d _a max	D _a max	r _a max
mm					mm			
65	76,3	113	1,5	71	74	76	111	1,5
	78,5	130	2,1	84	77	78,5	130	2
70	82	118	1,5	74	79	82	116	1,5
	84,2	139	2,1	89	82	84	139	2
75	84,6	123	1,5	77	84	84	121	1,5
	88,8	147	2,1	97	87	88,5	148	2



Four-point contact ball bearings

Designs	452
Basic design bearings	452
Bearings with locating slots.....	452
SKF Explorer class bearings	453
Bearing data – general	453
Dimensions.....	453
Tolerances.....	453
Internal clearance.....	453
Misalignment.....	454
Influence of operating temperature on bearing material.....	454
Cages.....	454
Minimum load.....	454
Equivalent dynamic bearing load.....	455
Equivalent static bearing load.....	455
Supplementary designations.....	455
Design of bearing arrangements	455
Product table	456

Designs

Four-point contact ball bearings are radial single row angular contact ball bearings with raceways that are designed to support axial loads acting in both directions. Radial loads can be supported up to a certain fraction of the axial load. These bearings take up considerably less axial space than double row bearings.

The standard range of SKF four-point contact ball bearings comprises bearings in the QJ 2 and QJ 3 series (→ **fig. 1**). They are available as

- basic design bearings or
- bearings with locating slots.

In addition, SKF four-point contact ball bearings are available in other dimension series, designs, and sizes. For information on these bearings, consult the “SKF Interactive Engineering Catalogue” on CD-ROM or online at www.skf.com.

Basic design bearings

Four-point contact ball bearings shown in this catalogue have a 35° contact angle and are designed to accommodate predominantly axial loads. The inner ring is split. This enables a large number of balls to be incorporated in the bearing thus giving the bearing high load carrying capacity. The bearings are separable, i.e. the outer ring with ball and cage assembly can be mounted separately from the two inner ring halves.

Both inner ring halves of SKF Explorer four-point contact ball bearings have a recessed shoulder. This improves the oil flow when the bearing is used together with an SKF cylindrical roller bearing (→ **fig. 2**). In addition, these recesses can be used to facilitate dismounting.

Bearings with locating slots

In many applications a radial bearing is used in combination with a four-point contact ball bearing which acts as a pure thrust bearing and is mounted with radial clearance in the housing (→ **fig. 2**). To restrain the outer ring from turning in the circumferential direction, bearings with two locating slots (designation suffix N2) in the outer ring positioned at 180° to each other are available (→ **fig. 3**).

Fig. 1

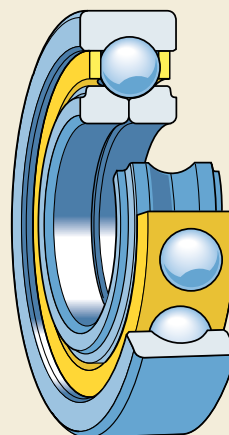

Fig. 2

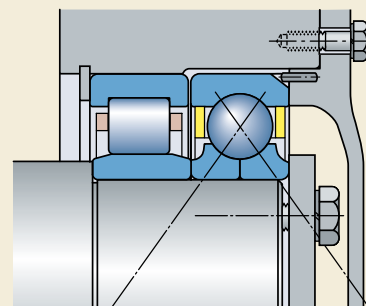
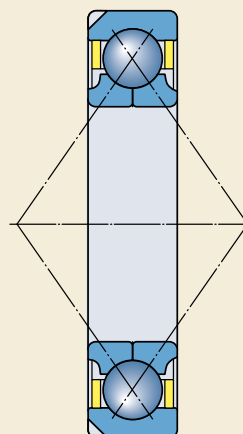

Fig. 3



SKF Explorer class bearings

High performance SKF Explorer four-point contact ball bearings are shown with an asterisk in the product table. SKF Explorer bearings retain the designation of the earlier standard bearings, e.g. QJ 309 N2MA. However, each bearing and its box are marked with the name “EXPLORER”.

SKF Explorer four-point contact ball bearings meet the specifications for P6 running accuracy. The dimensional accuracy complies with Normal tolerances, except that the width tolerance is reduced to 0/-40 µm.

The values for tolerances correspond to ISO 492:2002 and can be found in **tables 3** and **4** on **pages 125** and **126**.

Bearing data – general

Dimensions

The boundary dimensions of SKF four-point contact ball bearings are in accordance with ISO 15:1998.

Tolerances

SKF four-point contact ball bearings are produced as standard to Normal tolerances. Some sizes are also available with enhanced precision to tolerance class P6 specifications.

Internal clearance

SKF four-point contact ball bearings are supplied with Normal axial internal clearance as standard, but some sizes are available with greater or smaller clearance, or with reduced clearance limits.

The actual clearance limits are provided in **table 1** and are valid for bearings before mounting under zero measuring load.

Table 1

Axial internal clearance of four-point contact ball bearings

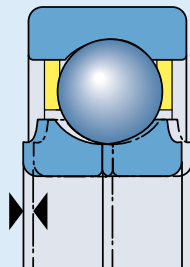

Bore diameter d		Axial internal clearance				C3		C4	
		C2		Normal					
over	incl.	min	max	min	max	min	max	min	max
mm		µm							
10	17	15	55	45	85	75	125	115	165
17	40	26	66	56	106	96	146	136	186
40	60	36	86	76	126	116	166	156	206
60	80	46	96	86	136	126	176	166	226
80	100	56	106	96	156	136	196	186	246
100	140	66	126	116	176	156	216	206	266
140	180	76	156	136	196	176	246	226	296
180	220	96	176	156	226	206	276	256	326

Four-point contact ball bearings

Misalignment

The ability of four-point contact ball bearings to tolerate misalignment of the inner ring with respect to the outer ring, and consequently the ability to compensate for misalignment in the application or to tolerate shaft deflections is limited. It depends on the internal clearance in operation, bearing size and the magnitude of the forces and moments acting on the bearing. The interrelationship of these factors is complex and no general rules can be provided.

Any misalignment will lead to increased running noise, cage stresses and reduced bearing service life.

Influence of operating temperature on bearing material

SKF four-point contact ball bearings undergo a special heat treatment. When fitted with a steel, brass or PEEK cage, they can operate at temperatures of up to +150 °C.

Cages

SKF four-point contact ball bearings are fitted with one of the following cages

- a machined window-type brass cage, outer ring centred, designation suffix MA (→ **fig. 4**).
- an injection moulded window-type cage of polyetheretherketone (PEEK) with lubrication grooves in the guiding surfaces, outer ring centred, designation suffix PHAS.

If bearings with a PEEK cage are required, other than listed, please contact the SKF application engineering service.

Minimum load

In order to provide satisfactory operation, four-point contact ball bearings, like all ball and roller bearings, must always be subjected to a given minimum load, particularly if they are to operate at high speeds or are subjected to high accelerations or rapid changes in the direction of load. Under such conditions, inertia forces of the balls and cage, and the friction in the lubricant, can have a detrimental influence on the rolling conditions in the bearing and may cause sliding damaging movements to occur between the balls and raceways.

The requisite minimum load to be applied to four-point contact ball bearings can be estimated using

$$F_{am} = k_a \frac{C_0}{1\,000} \left(\frac{n d_m}{100\,000} \right)^2$$

where

F_{am} = minimum axial load, kN

k_a = minimum axial load factor

1 for bearings in the QJ 2 series

1,1 for bearings in the QJ 3 series

C_0 = basic static load rating, kN

(→ product table)

n = rotational speed, r/min

d_m = bearing mean diameter
= 0,5 (d + D), mm

When starting up at low temperatures or when the lubricant is highly viscous, even greater minimum loads may be required. The weight of the components supported by the bearing, together with external forces, generally exceeds the requisite minimum load. If this is not the case, the four-point contact ball bearing must be subjected to an additional axial load, for example, by means of springs.

Fig. 4

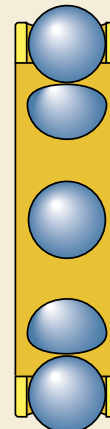

Equivalent dynamic bearing load

If four-point contact ball bearings are arranged as locating bearings and have to accommodate both radial and axial loads, the equivalent dynamic bearing load is obtained from

$$P = F_r + 0,66 F_a \quad \text{when } F_a/F_r \leq 0,95$$
$$P = 0,6 F_r + 1,07 F_a \quad \text{when } F_a/F_r > 0,95$$

It should be noted that four-point contact ball bearings will only function properly when the ball contacts at only one point on the outer ring raceway and at one point on the inner ring raceway. This is the case if the axial load $F_a \geq 1,27 F_r$.

If the four-point contact ball bearing is arranged with radial freedom in the housing to act as a thrust bearing in combination with a radial bearing (the usual arrangement for these bearings, → **fig. 2** on **page 452**), then the equivalent dynamic bearing load becomes

$$P = 1,07 F_a$$

Equivalent static bearing load

$$P_0 = F_r + 0,58 F_a$$

Supplementary designations

The designation suffixes used to identify certain features of SKF four-point contact ball bearings are explained in the following.

B20	Reduced width tolerance
C2	Axial internal clearance smaller than Normal
C2H	Axial internal clearance in the upper half of the C2 range
C2L	Axial internal clearance in the lower half of the C2 range
C3	Axial internal clearance greater than Normal
C4	Axial internal clearance greater than C3
CNL	Axial internal clearance in the lower half of the Normal range
FA	Machined window-type steel cage, outer ring centred
MA	Machined window-type brass cage, outer ring centred
N2	Two locating slots (notches), 180° apart, in the large outer ring side face

PHAS	Injection moulded window-type cage of polyetheretherketone (PEEK), with lubrication grooves in the guiding surfaces, outer ring centred
P6	Dimensional and running accuracy to ISO tolerance class 6
P63	P6 + C3
P64	P6 + C4
S1	Bearing rings dimensionally stabilized for use at operating temperatures up to +200 °C
344524	C2H + CNL

Design of bearing arrangements

The outer ring of bearings, which are arranged as thrust bearings with radial clearance in the housing, should not be clamped (→ **fig. 2**, **page 452**). Otherwise the outer ring cannot compensate for thermal movements, which will cause additional force in the bearing. If clamping the outer ring cannot be avoided, the outer ring must be at least carefully centred during mounting.

Four-point contact ball bearings

d 15 – 65 mm

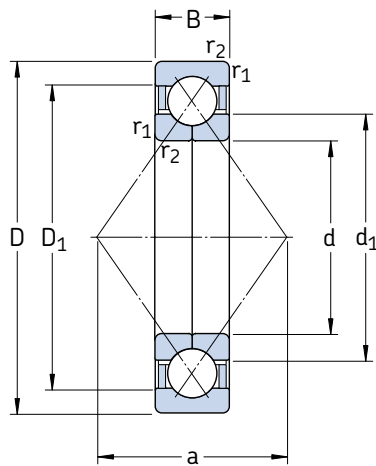

Basic design

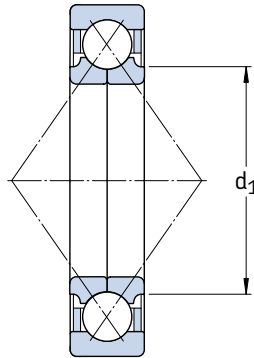

SKF Explorer bearing

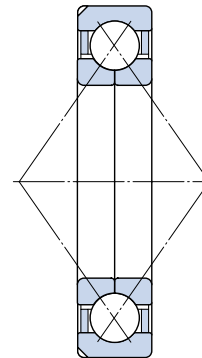

Bearing with locating slots

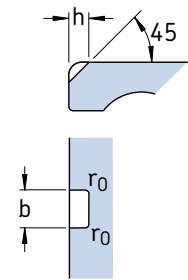

Principal dimensions			Basic load ratings dynamic static		Fatigue load limit	Speed ratings		Mass	Designations	
d	D	B	C	C ₀	P _u	Refer- ence speed	Limiting speed		Bearing with locating slots	without locating slots
mm			kN		kN	r/min		kg	–	
15	35	11	12,7	8,3	0,36	22 000	36 000	0,062	QJ 202 N2MA	–
17	40	12	17	11,4	0,45	22 000	30 000	0,082	* QJ 203 N2MA	–
	47	14	23,4	15	0,64	17 000	28 000	0,14	QJ 303 N2MA	–
20	52	15	32	21,6	0,85	18 000	24 000	0,18	* QJ 304 N2MA	* QJ 304 MA
	52	15	32	21,6	0,85	18 000	24 000	0,18	* QJ 304 N2PHAS	–
25	52	15	27	21,2	0,83	16 000	22 000	0,16	* QJ 205 N2MA	* QJ 205 MA
	62	17	42,5	30	1,18	15 000	20 000	0,29	* QJ 305 N2MA	* QJ 305 MA
30	62	16	37,5	30,5	1,2	14 000	19 000	0,24	* QJ 206 N2MA	* QJ 206 MA
	72	19	53	41,5	1,63	12 000	17 000	0,42	* QJ 306 N2MA	* QJ 306 MA
	72	19	53	41,5	1,63	12 000	17 000	0,42	* QJ 306 N2PHAS	–
35	72	17	49	41,5	1,63	12 000	17 000	0,36	* QJ 207 N2MA	–
	80	21	64	51	1,96	11 000	15 000	0,57	* QJ 307 N2MA	* QJ 307 MA
	80	21	64	51	1,96	11 000	15 000	0,57	* QJ 307 N2PHAS	–
40	80	18	56	49	1,9	11 000	15 000	0,45	* QJ 208 N2MA	* QJ 208 MA
	90	23	78	64	2,45	10 000	14 000	0,78	* QJ 308 N2MA	* QJ 308 MA
45	85	19	63	56	2,16	10 000	14 000	0,52	–	* QJ 209 MA
	100	25	100	83	3,25	9 000	12 000	1,05	* QJ 309 N2MA	* QJ 309 MA
	100	25	100	83	3,25	9 000	12 000	1,05	* QJ 309 N2PHAS	–
50	90	20	65,5	61	2,4	9 000	13 000	0,59	–	* QJ 210 MA
	110	27	118	100	3,9	8 000	11 000	1,35	–	* QJ 310 MA
	110	27	118	100	3,9	8 000	11 000	1,35	–	* QJ 310 PHAS
55	100	21	85	83	3,2	8 000	11 000	0,77	* QJ 211 N2MA	* QJ 211 MA
	120	29	137	118	4,55	7 000	10 000	1,75	* QJ 311 N2MA	* QJ 311 MA
60	110	22	96,5	93	3,65	7 500	10 000	0,99	* QJ 212 N2MA	* QJ 212 MA
	110	22	96,5	93	3,65	7 500	10 000	0,99	* QJ 212 N2PHAS	–
	130	31	156	137	5,3	6 700	9 000	2,15	* QJ 312 N2MA	* QJ 312 MA
65	120	23	110	112	4,4	6 700	9 500	1,20	* QJ 213 N2MA	* QJ 213 MA
	140	33	176	156	6,1	6 300	8 500	2,70	–	* QJ 313 MA

* SKF Explorer bearing

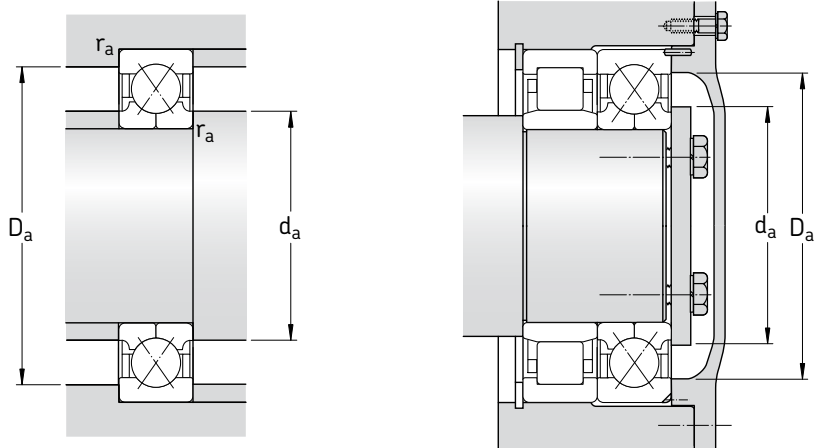

Dimensions					Slot dimensions			Abutment and fillet dimensions		
d	d ₁ ~	D ₁ ~	r _{1,2} min	a	b	h	r ₀	d _a min	D _a max	r _a max
mm					mm			mm		
15	22	28,1	0,6	18	3	2,2	0,5	19,2	30,8	0,6
17	23,5 27,7	32,5 36,3	0,6 1	20 22	3,5 4,5	2,5 3,5	0,5 0,5	21,2 22,6	35,8 41,4	0,6 1
20	27,5 27,5	40,8 40,8	1,1 1,1	25 25	4,5 4,5	3,5 3,5	0,5 0,5	27 27	45 45	1 1
25	31,5 34	43 49	1 1,1	27 30	4,5 4,5	3 3,5	0,5 0,5	30,6 32	46,4 55	1 1
30	37,5 40,5 40,5	50,8 58,2 58,2	1 1,1 1,1	32 36 36	4,5 4,5 4,5	3,5 3,5 3,5	0,5 0,5 0,5	35,6 37 37	56,4 65 65	1 1 1
35	44 46,2 46,2	59 64,3 64,3	1,1 1,5 1,5	37 40 40	4,5 5,5 5,5	3,5 4 4	0,5 0,5 0,5	42 44 44	65 71 71	1 1,5 1,5
40	49,5 52	66 72,5	1,1 1,5	42 46	5,5 5,5	4 4	0,5 0,5	47 49	73 81	1 1,5
45	54,5 58 58	72 81,2 81,2	1,1 1,5 1,5	46 51 51	– 6,5 6,5	– 5 5	– 0,5 0,5	52 54 54	78 91 91	1 1,5 1,5
50	59,5 65 65	76,5 90 90	1,1 2 2	49 56 56	5,5 – –	4 – –	0,5 – –	57 61 61	83 99 99	1 2 2
55	66 70,5	84,7 97,8	1,5 2	54 61	6,5 6,5	5 8,1	0,5 0,5	64 66	91 109	1,5 2
60	72 72 77	93 93 106	1,5 1,5 2,1	60 60 67	6,5 6,5 6,5	5 5 8,1	0,5 0,5 0,5	69 69 72	101 101 118	1,5 1,5 2
65	78,5 82,5	101 115	1,5 2,1	65 72	6,5 –	6,5 –	0,5 –	74 77	111 128	1,5 2

Four-point contact ball bearings

d 70 – 150 mm

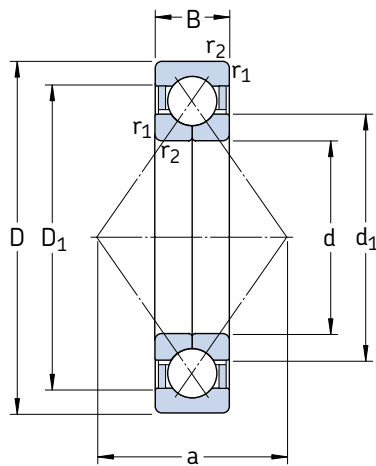

Basic design

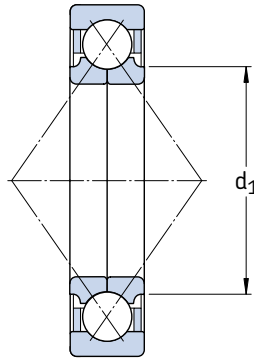

SKF Explorer bearing

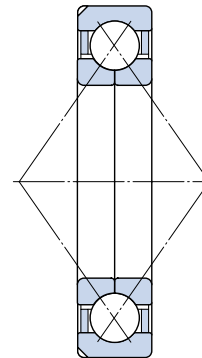

Bearing with locating slots

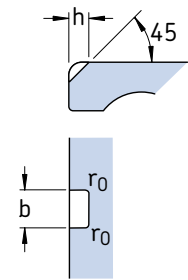

Principal dimensions			Basic load ratings dynamic static		Fatigue load limit	Speed ratings Reference speed Limiting speed		Mass	Designations Bearing with locating slots	without locating slots
d	D	B	C	C ₀	P _u					
mm			kN		kN	r/min		kg	–	
70	125	24	120	122	4,8	6 300	9 000	1,32	* QJ 214 N2MA	* QJ 214 MA
	125	24	120	122	4,8	6 300	9 000	1,32	* QJ 214 N2PHAS	–
	150	35	200	180	6,7	5 600	8 000	3,15	* QJ 314 N2MA	* QJ 314 MA
	150	35	200	180	6,7	5 600	8 000	3,15	* QJ 314 N2PHAS	–
75	130	25	125	132	5,2	6 300	8 500	1,45	* QJ 215 N2MA	* QJ 215 MA
	130	25	125	132	5,2	6 300	8 500	1,45	* QJ 215 N2PHAS	–
	160	37	199	186	7,35	4 500	7 500	3,90	QJ 315 N2MA	–
80	140	26	146	156	5,85	5 600	8 000	1,85	* QJ 216 N2MA	* QJ 216 MA
	170	39	216	208	8	4 300	7 000	4,60	QJ 316 N2MA	–
85	150	28	156	173	6,2	5 300	7 500	2,25	* QJ 217 N2MA	* QJ 217 MA
	180	41	234	236	8,65	4 000	6 700	5,45	QJ 317 N2MA	–
90	160	30	174	186	6,95	4 300	7 000	2,75	QJ 218 N2MA	–
	190	43	265	285	10,2	3 800	6 300	6,45	QJ 318 N2MA	–
95	170	32	199	212	7,8	4 000	6 700	3,35	QJ 219 N2MA	–
	200	45	286	315	11	3 600	6 000	7,45	QJ 319 N2MA	–
100	180	34	225	240	8,65	3 800	6 300	4,05	QJ 220 N2MA	–
	215	47	307	340	11,6	3 400	5 600	9,30	QJ 320 N2MA	–
110	200	38	265	305	10,4	3 400	5 600	5,60	QJ 222 N2MA	–
	240	50	390	475	15	3 000	4 800	12,5	QJ 322 N2MA	–
120	215	40	286	340	11,2	3 200	5 000	6,95	QJ 224 N2MA	–
	260	55	390	490	15	2 800	4 500	16,0	QJ 324 N2MA	–
130	230	40	296	365	11,6	2 800	4 800	7,75	QJ 226 N2MA	–
	280	58	423	560	16,6	2 600	4 000	19,5	QJ 326 N2MA	–
140	250	42	325	440	13,2	2 600	4 300	9,85	QJ 228 N2MA	–
	300	62	468	640	18,6	2 400	3 800	24,0	QJ 328 N2MA	–
150	270	45	377	530	15,3	2 400	4 000	12,5	QJ 230 N2MA	–
	320	65	494	710	19,6	2 200	3 600	29,0	QJ 330 N2MA	–

* SKF Explorer bearing

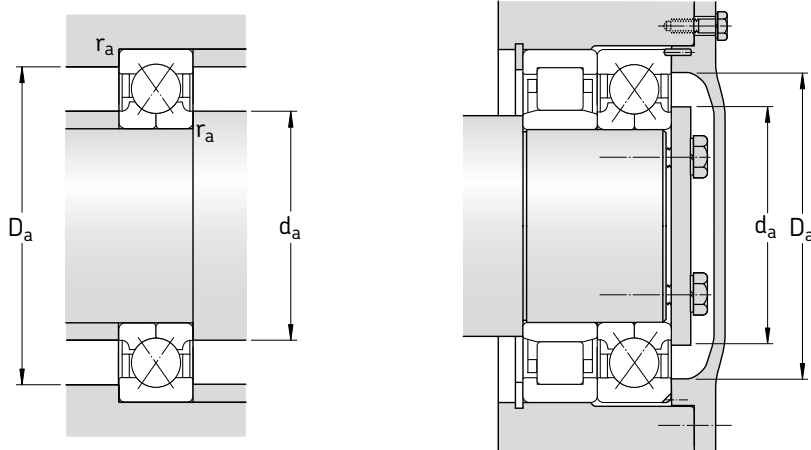

Dimensions					Slot dimensions			Abutment and fillet dimensions		
d	d ₁ ~	D ₁ ~	r _{1,2} min	a	b	h	r ₀	d _a min	D _a max	r _a max
mm					mm			mm		
70	83,5	106	1,5	68	6,5	6,5	0,5	79	116	1,5
	83,5	106	1,5	68	6,5	6,5	0,5	79	116	1,5
	89	123	2,1	77	8,5	10,1	2	82	138	2
	89	123	2,1	77	8,5	10,1	2	82	138	2
75	88,5	112	1,5	72	6,5	6,5	0,5	84	121	1,5
	88,5	112	1,5	72	6,5	6,5	0,5	84	121	1,5
	104	131	2,1	82	8,5	10,1	2	87	148	2
80	95,3	120	2	77	6,5	8,1	1	91	129	2
	111	139	2,1	88	8,5	10,1	2	92	158	2
85	100	128	2	83	6,5	8,1	1	96	139	2
	117	148	3	93	10,5	11,7	2	99	166	2,5
90	114	136	2	88	6,5	8,1	1	101	149	2
	124	156	3	98	10,5	11,7	2	104	176	2,5
95	120	145	2,1	93	6,5	8,1	1	107	158	2
	131	165	3	103	10,5	11,7	2	109	186	2,5
100	127	153	2,1	98	8,5	10,1	2	112	168	2
	139	176	3	110	10,5	11,7	2	114	201	2,5
110	141	169	2,1	109	8,5	10,1	2	122	188	2
	154	196	3	123	10,5	11,7	2	124	226	2,5
120	152	183	2,1	117	10,5	11,7	2	132	203	2
	169	211	3	133	10,5	11,7	2	134	246	2,5
130	165	195	3	126	10,5	11,7	2	144	216	2,5
	182	227	4	144	10,5	12,7	2	147	263	3
140	179	211	3	137	10,5	11,7	2	154	236	2,5
	196	244	4	154	10,5	12,7	2	157	283	3
150	194	226	3	147	10,5	11,7	2	164	256	2,5
	211	259	4	165	10,5	12,7	2	167	303	3

Four-point contact ball bearings
d 160 – 200 mm

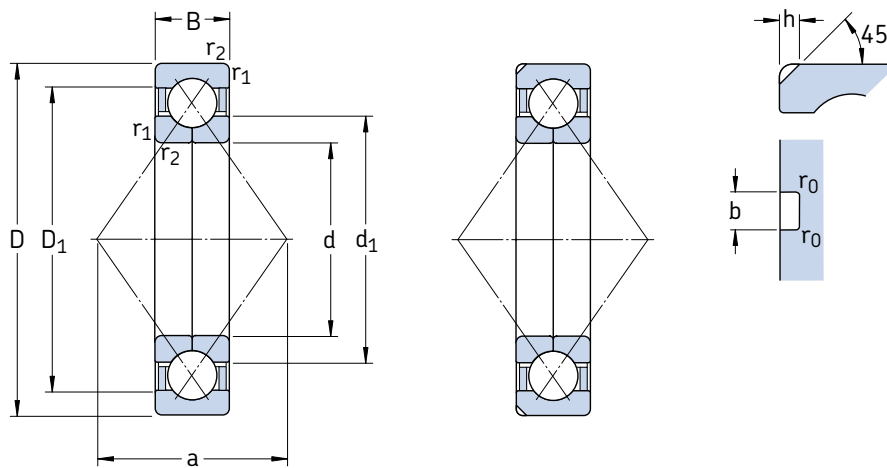

Basic design

Bearing with locating slots

Principal dimensions			Basic load ratings dynamic static		Fatigue load limit P_u	Speed ratings Reference speed Limiting speed		Mass	Designation Bearing with locating slots
d	D	B	C	C_0					
mm			kN		kN	r/min		kg	–
160	290	48	423	620	17,6	2 200	3 800	15,5	QJ 232 N2MA
	340	68	540	815	21,6	2 000	3 400	34,5	QJ 332 N2MA
170	310	52	436	670	18,3	2 200	3 400	19,5	QJ 234 N2MA
	360	72	618	965	25	1 900	3 200	41,5	QJ 334 N2MA
180	320	52	449	710	19	2 000	3 400	20,5	QJ 236 N2MA
	380	75	637	1 020	26	1 800	3 000	47,5	QJ 336 N2MA
190	400	78	702	1 160	28,5	1 700	2 800	49,0	QJ 338 N2MA
200	360	58	540	915	23,2	1 800	3 000	28,5	QJ 240 N2MA

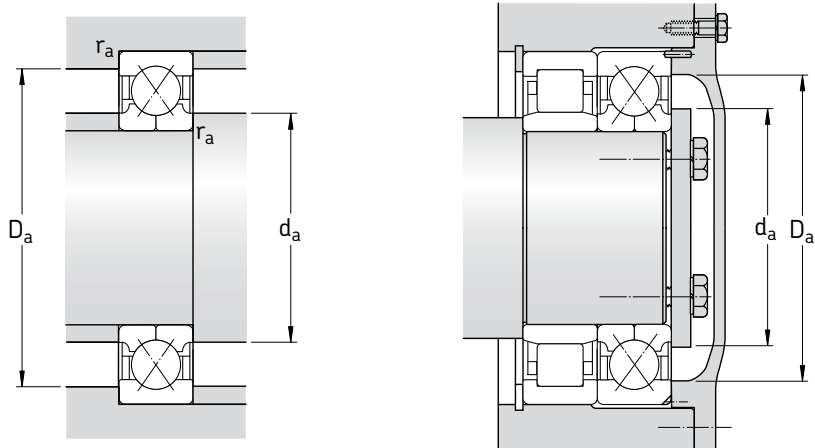

Dimensions					Slot dimensions			Abutment and fillet dimensions		
d	d ₁ ~	D ₁ ~	r _{1,2} min	a	b	h	r ₀	d _a min	D _a max	r _a max
mm					mm			mm		
160	206	243	3	158	10,5	12,7	2	174	276	2,5
	224	276	4	175	10,5	12,7	2	177	323	3
170	221	258	4	168	10,5	12,7	2	187	293	3
	237	293	4	186	10,5	12,7	2	187	343	3
180	231	269	4	175	10,5	12,7	2	197	303	3
	252	309	4	196	10,5	12,7	2	197	363	3
190	263	326	5	207	10,5	12,7	2	210	380	4
200	258	302	4	196	10,5	12,7	2	217	363	3

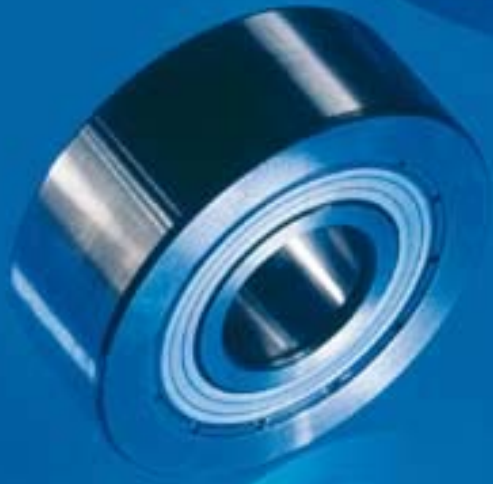

Double row cam rollers

Designs	464
Cam roller data – general	464
Dimensions	464
Tolerances	464
Internal clearance	464
Cages	465
Load carrying ability	465
Axial load carrying capacity	465
Design of associated components	465
Pins	465
Guide flanges	465
Lubrication	465
Product table	466

Designs

SKF double row cam rollers (→ **fig. 1**) have been developed from double row angular contact ball bearings and have a 25° contact angle. They are ready-to-mount pre-greased units and are used for all types of cam drives, conveyor systems etc. They are fitted with pressed steel shields which form a long sealing gap with the inner ring shoulder to keep the lubricant in and contamination out.

Double row SKF cam rollers are available in two designs

- with a crowned runner surface, series 3058(00) C-2Z
- with a cylindrical (flat) runner surface, series 3057(00) C-2Z.

Cam rollers with crowned runner surfaces should be used where there is angular misalignment with respect to the track and where edge stresses need to be minimized. In addition to the double row cam rollers, the SKF standard range of track runner bearings contains other cam rollers, support rollers, and cam followers. These are, for example

- single row cam rollers, series 3612(00) R (→ **page 399**)
- support rollers based on needle roller or cylindrical roller bearings
- cam followers based on needle roller or cylindrical roller bearings.

For additional information on support rollers and cam followers, consult the catalogue “Needle roller bearings” or the “SKF Interactive Engineering Catalogue” on CD-ROM or online at www.skf.com.

Cam roller data – general

Dimensions

Except for the outside diameter, boundary dimensions of SKF double row cam rollers are in accordance with ISO 15:1998 for bearings in the 32 dimension series.

Fig. 1

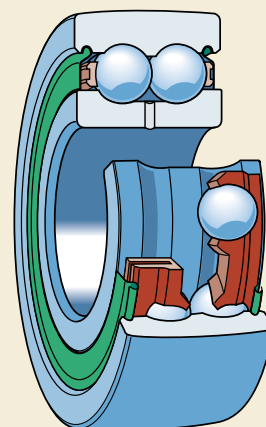
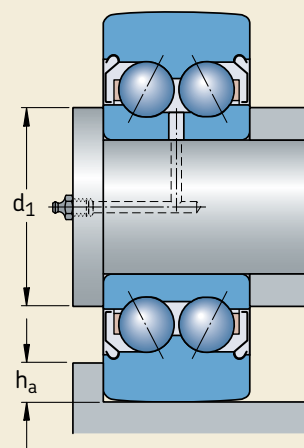

Fig. 2



Tolerances

SKF double row cam rollers are produced to Normal tolerances as standard, except for the tolerance of the diameter of the crowned runner surface, which is twice the Normal tolerance.

The values for tolerances correspond to ISO 492:2002 and can be found in **table 3** on **page 125**.

Internal clearance

Double row cam rollers are produced with the Normal axial internal clearance of double row angular contact ball bearings (→ **table 2** on **page 438**).

Cages

Double row cam rollers are fitted with two injection moulded snap-type cages of glass fibre reinforced polyamide 6,6, ball centred, no designation suffix. They can operate at temperatures of up to +120 °C.

Load carrying ability

In contrast to normal ball bearings, where the outer ring is supported over its entire outside diameter surface in the bore of a housing, the outer ring of a cam roller has only a small contact area with the surface against which it runs, e.g. a rail or cam. The actual contact area depends on the applied radial load and whether the runner surface is crowned or cylindrical. The deformation of the outer ring caused by this limited contact alters the force distribution in the bearing and thus has an influence on load carrying ability. The basic load ratings provided in the product table take this into account.

The ability to carry dynamic loads depends on the requisite life, but with reference to the deformation and the strength of the outer ring, the value of the maximum dynamic radial load F_r must not be exceeded.

The permissible static load for a cam roller is determined by the smaller of the values of F_{0r} and C_0 . If requirements regarding smooth running are below normal, the static load may exceed C_0 but should never exceed the maximum permissible static radial load F_{0r} .

Axial load carrying capacity

Cam rollers are intended for predominantly radial loads. If an axial load acts on the outer ring, as when the cam roller runs against a guide flange, it will produce a tilting moment and the service life of the cam roller may be reduced as a consequence.

Design of associated components

Pins

With few exceptions, cam rollers operate with outer ring rotation. If easy displacement of the inner ring is required, the pin or shaft should be machined to a g6 tolerance. If, however, a tighter fit is required, then the pin or shaft should be machined to a j6 tolerance.

For cam rollers subjected to heavier axial loads, the inner ring should be supported over its entire side face (→ **fig. 2**). The diameter of the supporting surface should be the same as the face diameter d_1 of the inner ring.

Guide flanges

For rails or cams with guide flanges (→ **fig. 2**), the recommended flange height h_a should not exceed

$$h_a = 0,5 (D - D_1)$$

This helps to avoid damage to shields fitted in the outer ring. The values for the outer ring diameters D and D_1 are listed in the product table.

Lubrication

SKF double row cam rollers are filled with a grease with lithium thickener of consistency 3 to the NLGI Scale. This grease has good rust inhibiting properties and has a temperature range of –30 to +120 °C. The base oil viscosity is 98 mm²/s at 40 °C and 9,4 mm²/s at 100 °C.

Under normal operating conditions, these cam rollers are maintenance-free. However, if they are subjected to moisture or solid contaminants, or if they run for long periods at temperatures above 70 °C they should be relubricated. The inner ring has a lubrication hole for this purpose. A grease with lithium thickener should be used for relubrication, preferably the SKF LGMT 3 grease. The grease should be applied slowly to avoid damaging the shields.

Double row cam rollers
D 32 – 80 mm

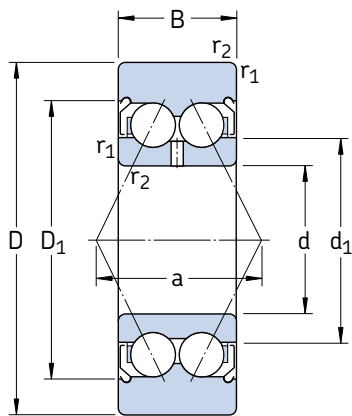

3057(00) C-2Z

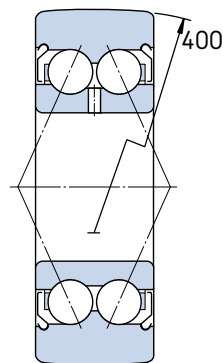

3058(00) C-2Z

Dimensions							Limiting speed	Mass	Designations	
D	B	d	d_1	D_1	$r_{1,2}$ min	a			Cam roller with crowned runner surface	cylindrical runner surface
mm							r/min	kg	-	
32	14	10	17,7	25	0,6	15	11 000	0,062	305800 C-2Z	-
35	15,9	12	19,1	27,7	0,6	16,5	9 500	0,078	305801 C-2Z	305701 C-2Z
40	15,9	15	22,1	30,7	0,6	18	8 500	0,10	305802 C-2Z	305702 C-2Z
47	17,5	17	25,2	35	0,6	20	8 000	0,16	305803 C-2Z	305703 C-2Z
52	20,6	20	29,4	40,9	1	24	7 000	0,22	305804 C-2Z	305704 C-2Z
62	20,6	25	34,4	45,9	1	26,5	6 000	0,32	305805 C-2Z	305705 C-2Z
72	23,8	30	41,4	55,2	1	31	5 000	0,49	305806 C-2Z	305706 C-2Z
80	27	35	48,1	63,9	1,1	36,5	4 300	0,65	305807 C-2Z	305707 C-2Z

Outside diameter D	Basic load ratings		Fatigue load limit P _u	Maximum radial loads	
	dynamic C	static C ₀		dynamic F _r	static F _{0r}
mm	kN		kN	kN	
32	7,15	3,8	0,16	4,4	6,3
35	9,56	4,9	0,208	3,8	5,4
40	10,6	5,85	0,25	5,85	8,5
47	13,5	7,8	0,325	9,3	13,4
52	17,2	10	0,425	8,3	12
62	19,5	12,5	0,53	15,3	21,6
72	27,6	18,6	0,8	17	24
80	33,2	21,2	0,9	15,6	22,4



Self-aligning ball bearings



Designs	470
Basic design.....	470
Sealed bearings.....	470
Bearings with an extended inner ring	470
Bearings on sleeves	471
Self-aligning ball bearing kits	474
Appropriate bearing housings	475
Bearing data – general	476
Dimensions.....	476
Tolerances.....	476
Misalignment.....	476
Internal clearance.....	476
Cages.....	478
Axial load carrying capacity.....	478
Minimum load.....	479
Equivalent dynamic bearing load.....	479
Equivalent static bearing load.....	479
Supplementary designations.....	479
Mounting bearings with a tapered bore	480
Measuring the clearance reduction	480
Measuring the lock nut tightening angle	481
Measuring the axial drive-up	481
Additional mounting information	482
Product tables	484
Self-aligning ball bearings.....	484
Sealed self-aligning ball bearings	492
Self-aligning ball bearings with extended inner ring	494
Self-aligning ball bearings on adapter sleeve.....	496

Designs

The self-aligning ball bearing was invented by SKF. It has two rows of balls and a common sphered raceway in the outer ring. The bearing is consequently self-aligning and insensitive to angular misalignments of the shaft relative to the housing. It is particularly suitable for applications where considerable shaft deflections or misalignment are to be expected. Additionally, the self-aligning ball bearing has the lowest friction of all rolling bearings, which enables it to run cooler even at high speeds.

SKF produces self-aligning ball bearings to several designs. These are

- open bearings of the basic design (→ **fig. 1**)
- sealed bearings (→ **fig. 2**)
- open bearings with an extended inner ring (→ **fig. 3**).

Basic design

The basic design self-aligning ball bearing is available with a cylindrical bore or, in certain size ranges, with a tapered bore (taper 1:12).

Large self-aligning ball bearings in the 130 and 139 series originally developed for specific applications in paper mills, can be used in any application where low friction is preferred over high load carrying capacity. These bearings are provided with an annular groove and lubrication holes in the outer ring and lubrication holes in the inner ring (→ **fig. 4**).

The balls of some bearings in the 12 and 13 series protrude from the sides of the bearing. The values of the protrusion are provided in **table 1** and should be considered when designing the associated components of the bearing arrangement.

Sealed bearings

SKF self-aligning ball bearings are also available in a sealed version with contact seals on both sides – designation suffix 2RS1 (→ **fig.5**). These sheet steel reinforced seals are made of oil and wear-resistant acrylonitrile-butadiene rubber (NBR). The permissible operating temperature range for these seals is -40 to $+100$ °C and up to $+120$ °C for brief periods. The seal lip contacts a smooth chamfer on the inner ring with light pressure.

Fig. 1

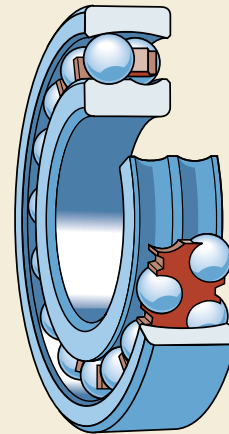

Fig. 2

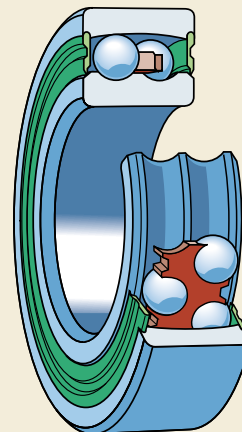

Fig. 3

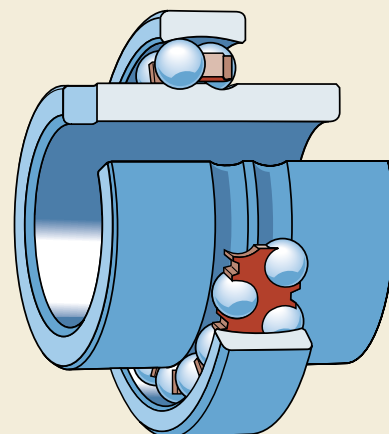

Fig. 4

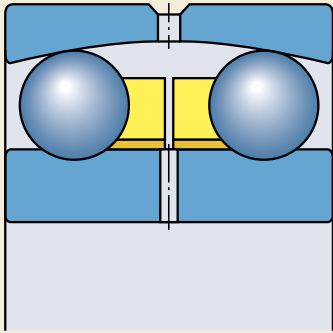
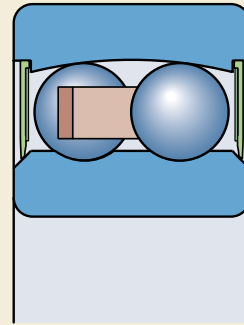

Fig. 5



Sealed bearings are lubricated as standard with a grease with lithium thickener that has good rust inhibiting properties and other characteristics according to **table 2**.

SKF sealed self-aligning ball bearings are available with a cylindrical bore. Some sizes are also available with a tapered bore (taper 1:12).

Note

Sealed bearings are lubricated for life and require no maintenance. They should not be heated above 80 °C before mounting and should not be washed.

Table 1

Protrusion of balls from bearing side faces

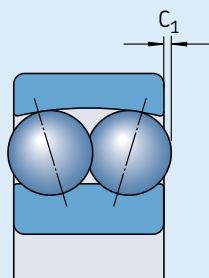

Bearing	Protrusion C ₁ mm
–	mm
1224 (K) 1226	1,3 1,4
1318 (K) 1319 (K)	1 1,5
1320 (K) 1322 (K)	2,5 2,6

Table 2

SKF standard grease filling for sealed self-aligning ball bearings

Technical specification	SKF greases MT47	MT33
Bearing outside diameter, mm	≤ 62	>62
Thickener	Lithium soap	Lithium soap
Base oil type	Mineral oil	Mineral oil
NLGI consistency class	2	3
Temperature range, °C ¹⁾	–30 to +110	–30 to +120
Base oil viscosity, mm ² /s at 40 °C at 100 °C	70 7,3	98 9,4

¹⁾ For safe operating temperature, → section “Temperature range – the SKF traffic light concept”, starting on **page 232**

Self-aligning ball bearings

Bearings with an extended inner ring

Self-aligning ball bearings with an extended inner ring are designed for less demanding applications using commercial grade shafting. The special bore tolerance enables easy mounting and dismounting.

Self-aligning ball bearings with an extended inner ring are axially located on the shaft by means of a pin or shouldered screw (→ **fig. 6**), which engages in a slot at one side of the inner ring and prevents the inner ring from turning on the shaft.

When two self-aligning ball bearings with an extended inner ring are used to support a shaft, they should be positioned so that the inner ring slots either face each other, or are at the out-board positions of the bearings (→ **fig. 7**). If this is not the case, the shaft is axially located in one direction only.

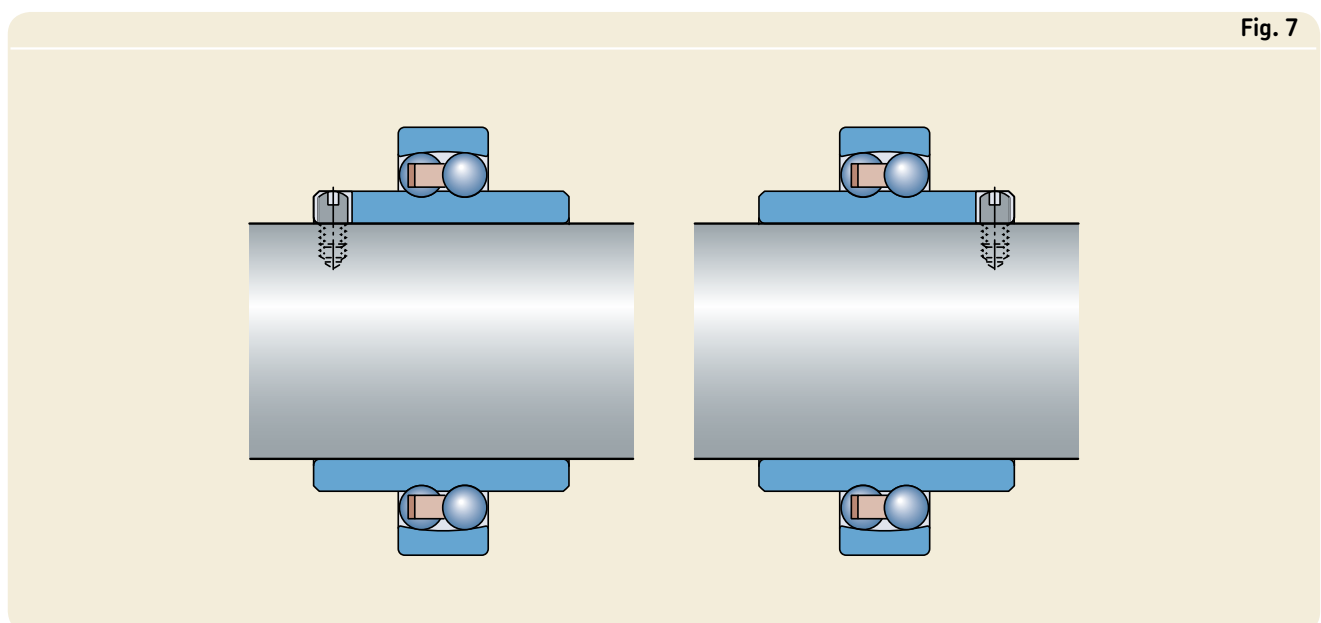
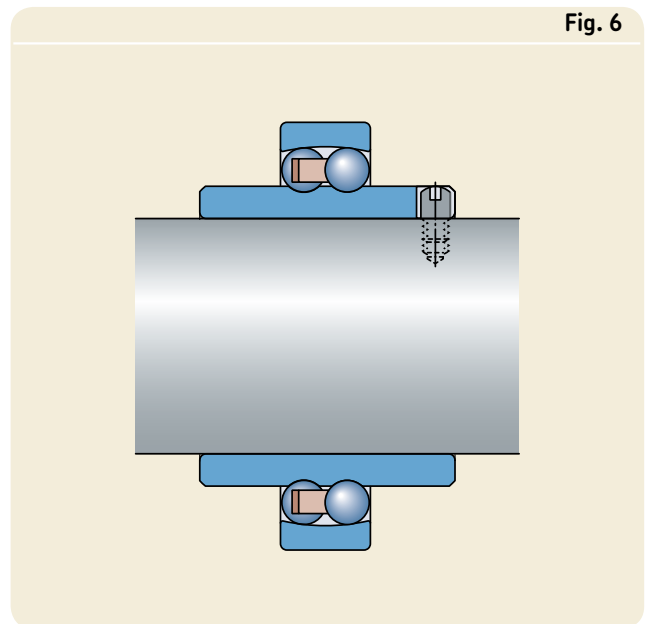

Bearings on sleeves

Adapter and withdrawal sleeves are used to secure bearings with a tapered bore onto cylindrical shaft seats. They facilitate bearing mounting and dismantling and often simplify bearing arrangement design.

Adapter sleeves (→ **figs. 8 and 9**) are more popular than withdrawal sleeves (→ **fig. 10**) as they do not require axial locating devices on the shaft. That is why only adapter sleeves are shown together with suitable bearings in the product table, starting on **page 496**.

SKF adapter sleeves are slotted and are supplied complete with lock nut and locking device. The adapter sleeves for use with sealed self-aligning ball bearings are equipped with a special locking washer that has a protrusion on the side facing the bearing, in order to prevent the seal from being damaged (→ **fig. 11**). These sleeves are identified by the suffix C.

Fig. 8

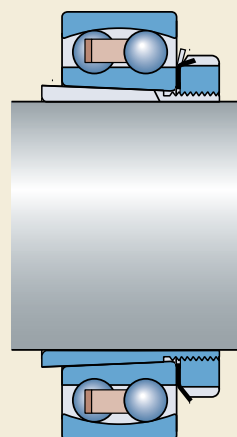

Fig. 9

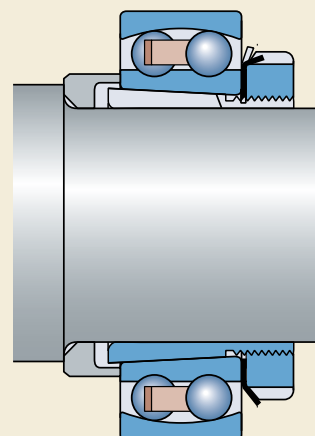

Fig. 11

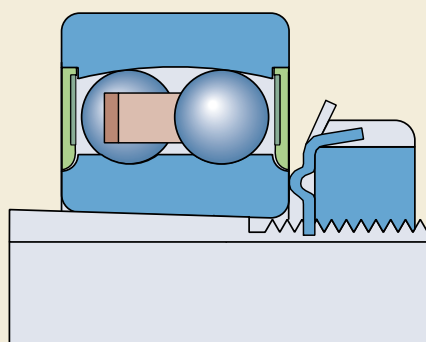
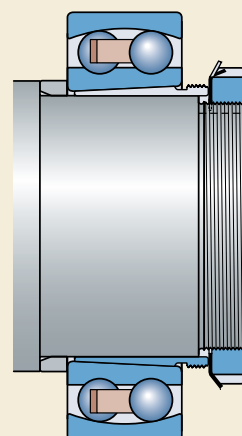

Fig. 10



Self-aligning ball bearing kits

To facilitate procurement and to provide the correct bearing/sleeve combination, SKF offers the most popular self-aligning ball bearings together with the suitable adapter sleeve as a kit (→ **fig. 12**).

Mounting can easily be performed with the help of the SKF lock nut spanner set TMHN 7 (→ **page 1070**).

The range of these kits is shown in **table 3**.

Table 3

SKF self-aligning ball bearing/adapter sleeve kits				
Bearing kit Designation	Parts Designation	Bearing	Sleeve	Shaft diameter mm
KAM 1206	1206 EKTN9/C3	H 206		25
KAM 1207	1207 EKTN9/C3	H 207		30
KAM 1208	1208 EKTN9/C3	H 208		35
KAM 1209	1209 EKTN9/C3	H 209		40
KAM 1210	1210 EKTN9/C3	H 210		45
KAM 1211	1211 EKTN9/C3	H 211		50

The technical data are provided in the product table on pages 496 to 499

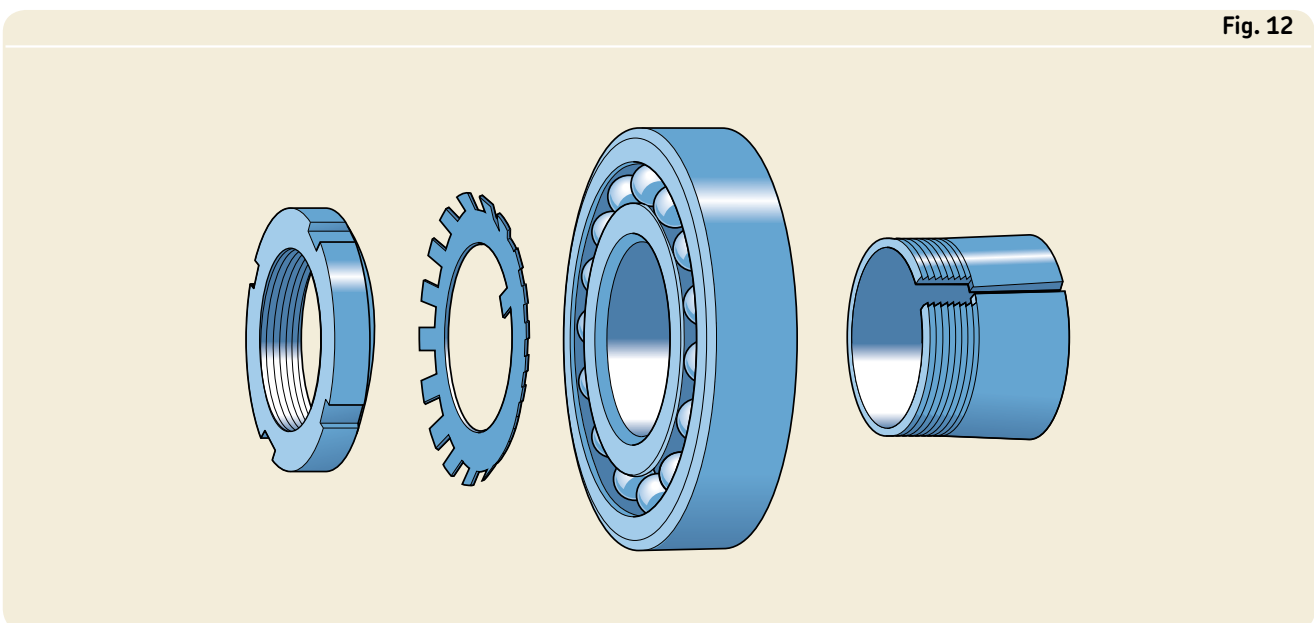

Fig. 12

Appropriate bearing housings

Self-aligning ball bearings with a cylindrical bore or with a tapered bore on adapter sleeve can be mounted in a variety of housings, such as

- SNL plummer (pillow) block housings in the 2, 3, 5 and 6 series (→ **fig. 13**)
- TVN housings
- 7225(00) flanged housings
- SAF plummer (pillow) block housings for inch-size shafts.

Bearings with an extended inner ring can be mounted in specially designed housings, such as

- TN housings
- I-1200(00) flanged housings.

A brief description of these housings is provided in the section “Bearing housings”, starting on **page 1031**. Detailed information on these housings can be found in the “SKF Interactive Engineering Catalogue” on CD-ROM or online at www.skf.com.

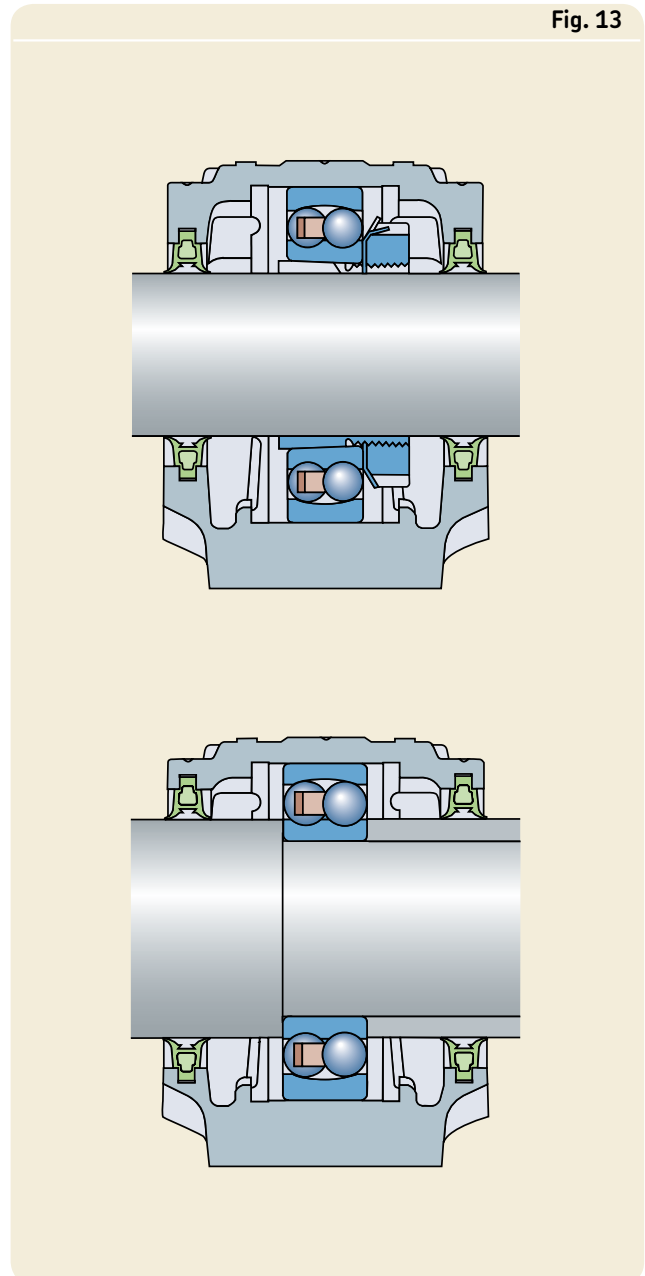

Bearing data – general

Dimensions

The boundary dimensions of SKF self-aligning ball bearings, with the exception of those with an extended inner ring, are in accordance with ISO 15:1998. The dimensions of the bearings with an extended inner ring follow DIN 630, part 2, withdrawn in 1993.

Tolerances

SKF self-aligning ball bearings are manufactured as standard to Normal tolerances, except the bore of the bearings with extended inner ring, which is produced to tolerance JS7.

The values of the Normal tolerances are in accordance with ISO 492:2002 and can be found in **table 3** on **page 125**.

Misalignment

The design of self-aligning ball bearings is such that angular misalignment between the outer and the inner rings can be accommodated without any negative effect on bearing performance.

Guideline values for the permissible angular misalignment between outer and inner rings under normal operating conditions are provided in **table 4**. Whether these values can be fully exploited depend on the bearing arrangement design and the type of seal used.

Internal clearance

SKF self-aligning ball bearings are produced as standard with Normal radial internal clearance and most are also available with the greater C3 clearance. Many bearings can also be supplied with the smaller C2 clearance or the much greater C4 clearance.

Bearings in the 130 and 139 series have C3 radial internal clearance as standard.

Bearings with an extended inner ring have a radial internal clearance which lies in the C2 + Normal range.

Clearance values are provided in **table 5** and are in accordance with ISO 5753:1991. They are valid for unmounted bearings under zero measuring loads.

Table 4

Permissible angular misalignment

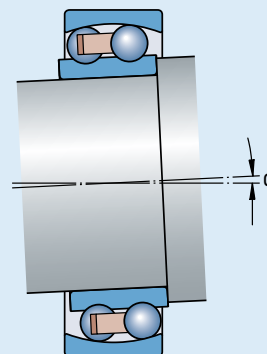

Bearings/ series	Misalignment α
–	degrees
108, 126, 127, 129, 135	3
12 (E)	2,5
13 (E)	3
22 (E)	2,5
22 E-2RS1	1,5
23 (E)	3
23 E-2RS1	1,5
112 (E)	2,5
130, 139	3

Table 5

Radial internal clearance of self-aligning ball bearings

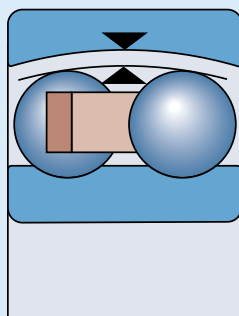

Bore diameter d		Radial internal clearance							
over	incl.	C2		Normal		C3		C4	
		min	max	min	max	min	max	min	max
mm		µm							
Bearings with a cylindrical bore									
2,5	6	1	8	5	15	10	20	15	25
6	10	2	9	6	17	12	25	19	33
10	14	2	10	6	19	13	26	21	35
14	18	3	12	8	21	15	28	23	37
18	24	4	14	10	23	17	30	25	39
24	30	5	16	11	24	19	35	29	46
30	40	6	18	13	29	23	40	34	53
40	50	6	19	14	31	25	44	37	57
50	65	7	21	16	36	30	50	45	69
65	80	8	24	18	40	35	60	54	83
80	100	9	27	22	48	42	70	64	96
100	120	10	31	25	56	50	83	75	114
120	140	10	38	30	68	60	100	90	135
140	150	–	–	–	–	70	120	–	–
150	180	–	–	–	–	80	130	–	–
180	200	–	–	–	–	90	150	–	–
200	220	–	–	–	–	100	165	–	–
220	240	–	–	–	–	110	180	–	–
Bearings with a tapered bore									
18	24	7	17	13	26	20	33	28	42
24	30	9	20	15	28	23	39	33	50
30	40	12	24	19	35	29	46	40	59
40	50	14	27	22	39	33	52	45	65
50	65	18	32	27	47	41	61	56	80
65	80	23	39	35	57	50	75	69	98
80	100	29	47	42	68	62	90	84	116
100	120	35	56	50	81	75	108	100	139

Please refer to **page 137** for the definition of radial internal clearance

Self-aligning ball bearings

Cages

Depending on the bearing series and size, SKF self-aligning ball bearings are fitted as standard with one of the following cages (→ **fig. 14**)

- a one-piece pressed steel cage, ball centred, no designation suffix (**a**)
- a two-piece pressed steel cage, ball centred, no designation suffix (**b**)
- a one-piece (**c**) or two-piece injection moulded snap-type cage of glass fibre reinforced polyamide 6,6, ball centred, designation suffix TN9
- a one-piece (**c**) or two-piece injection moulded snap-type cage of polyamide 6,6, ball centred, designation suffix TN
- a one-piece or two-piece (**d**) machined brass cage, ball centred, designation suffix M or no suffix (large size).

Contact SKF for availability of bearings with non-standard cages.

Note

Self-aligning ball bearings with polyamide 6,6 cages can be operated at temperatures up to +120 °C. The lubricants generally used for rolling bearings do not have a detrimental effect on cage properties, with the exception of a few synthetic oils and greases with a synthetic oil base, and lubricants containing a high proportion of EP additives when used at high temperatures.

For bearing arrangements, which are to be operated at continuously high temperatures or under arduous conditions, it is recommended to

use bearings with a pressed steel or machined brass cage.

For detailed information about the temperature resistance and the applicability of cages, please refer to the section “Cage materials”, starting on **page 140**.

Axial load carrying capacity

The ability of a self-aligning ball bearing mounted on an adapter sleeve on smooth shafts without an integral shoulder to carry axial loads, depends on the friction between the sleeve and shaft. The permissible axial load can be approximately determined from

$$F_{ap} = 0,003 B d$$

where

F_{ap} = maximum permissible axial load, kN

B = bearing width, mm

d = bearing bore diameter, mm

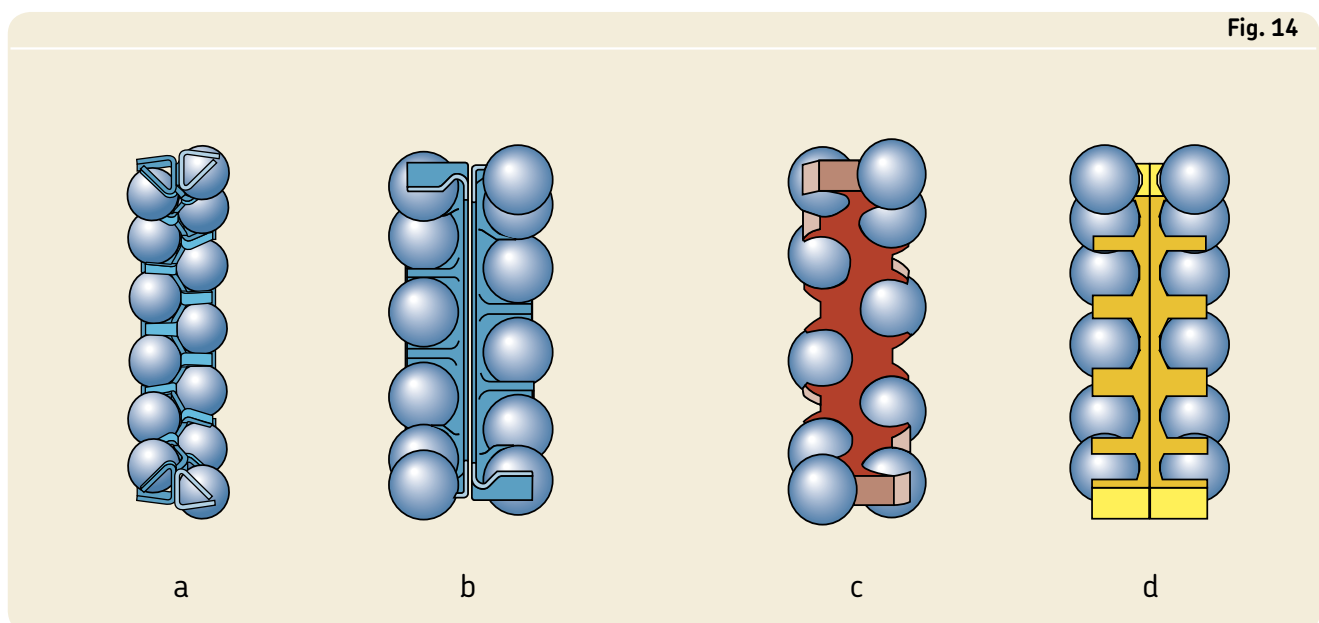

Minimum load

In order to provide satisfactory operation, self-aligning ball bearings, like all ball and roller bearings, must always be subjected to a given minimum load, particularly if they are to operate at high speeds or are subjected to high accelerations or rapid changes in the direction of load. Under such conditions, the inertia forces of the balls and cage, and the friction in the lubricant, can have a detrimental influence on the rolling conditions in the bearing arrangement and may cause damaging sliding movements to occur between the balls and raceways.

The requisite minimum load to be applied to self-aligning ball bearings can be estimated using

$$P_m = 0,01 C_0$$

where

P_m = equivalent minimum load, kN

C_0 = basic static load rating, kN

(→ product tables)

When starting up at low temperatures or when the lubricant is highly viscous, even greater minimum loads may be required. The weight of the components supported by the bearing, together with external forces, generally exceeds the requisite minimum load. If this is not the case, the self-aligning ball bearing must be subjected to an additional radial load, for example, by increasing belt tension or by similar means.

Equivalent dynamic bearing load

$$P = F_r + Y_1 F_a \quad \text{when } F_a/F_r \leq e$$

$$P = 0,65 F_r + Y_2 F_a \quad \text{when } F_a/F_r > e$$

Values of Y_1 , Y_2 and e can be found in the product tables.

Equivalent static bearing load

$$P_0 = F_r + Y_0 F_a$$

Values of Y_0 can be found in the product tables.

Supplementary designations

The designation suffixes used to identify certain features of SKF self-aligning ball bearings are explained in the following.

- C3** Radial internal clearance greater than Normal
- E** Optimized internal design
- K** Tapered bore, taper 1:12
- M** Machined brass cage, ball centred
- TN** Injection moulded snap-type cage of polyamide 6,6, ball centred
- TN9** Injection moulded snap-type cage of glass fibre reinforced polyamide 6,6, ball centred
- 2RS1** Sheet steel reinforced contact seal of acrylonitrile-butadiene rubber (NBR) on both sides of the bearing

Mounting bearings with a tapered bore

Self-aligning ball bearings with a tapered bore are always mounted with an interference fit on a tapered shaft seating or an adapter or withdrawal sleeve. As a measure of the degree of interference of the fit, either the reduction in radial internal clearance of the bearing or the axial displacement of the inner ring on its tapered seating is used.

Suitable methods for mounting self-aligning ball bearings with tapered bore are:

- Measuring the clearance reduction.
- Measuring the lock nut tightening angle.
- Measuring the axial drive-up.

Measuring the clearance reduction

When mounting basic design self-aligning ball bearings with the relatively small Normal radial internal clearance, it is generally sufficient to check clearance during the drive-up by turning and swivelling out the outer ring. When the bearing is properly mounted the outer ring can be easily turned but there should be a slight resistance when the outer ring is swivelled out. The bearing will then have the requisite interference fit. In some cases the residual internal clearance may be too small for the application, and a bearing with C3 radial internal clearance should be used instead.

Table 6

Mounting self-aligning ball bearings with a tapered bore

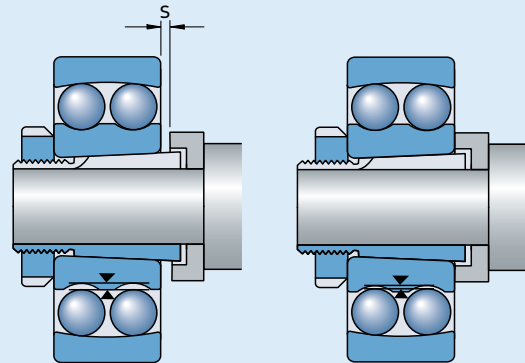

Bore diameter d	Tightening angle α	Axial drive-up s
mm	degrees	mm
20	80	0,22
25	55	0,22
30	55	0,22
35	70	0,30
40	70	0,30
45	80	0,35
50	80	0,35
55	75	0,40
60	75	0,40
65	80	0,40
70	80	0,40
75	85	0,45
80	85	0,45
85	110	0,60
90	110	0,60
95	110	0,60
100	110	0,60
110	125	0,70
120	125	0,70

Measuring the lock nut tightening angle

The procedure for using the nut tightening angle α (\rightarrow **fig. 15**) represents an easy method for mounting self-aligning ball bearings with a tapered bore correctly. Recommended values for the nut tightening angle α are provided in **table 6**.

Before starting the final tightening procedure, the bearing should be pushed up on the tapered seating until the bore of the bearing or sleeve is in contact with the seating on the shaft around its whole circumference, i.e. the bearing inner ring cannot be rotated relatively to the shaft. By then turning the nut through the given angle α , the bearing will be pressed up the tapered seating. The residual clearance of the bearing should be checked by turning and swivelling out the outer ring.

Then unscrew the nut, place the locking washer in position and tighten the nut firmly again. Lock the nut by bending one of the locking washer tabs into one of the nut slots.

Measuring the axial drive-up

Mounting bearings with a tapered bore can be done by measuring the axial drive-up of the inner ring on its seating. Recommended values for the required axial drive-up “s” for general applications are provided in **table 6**.

The most suitable method in this case is the SKF Drive-up Method. This mounting method provides a very reliable and easy way to determine the starting position for a bearing from which the axial displacement is to be measured. For that, the following mounting tools (\rightarrow **fig. 16**) must be used

- an SKF hydraulic nut of the HMV .. E design (**a**)
- an appropriate hydraulic pump (**b**)
- a pressure gauge (**c**), appropriate to the mounting conditions
- a dial gauge (**d**).

Fig. 15

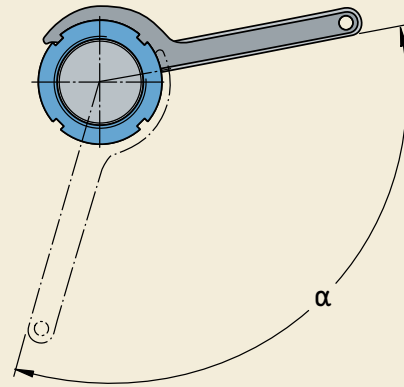
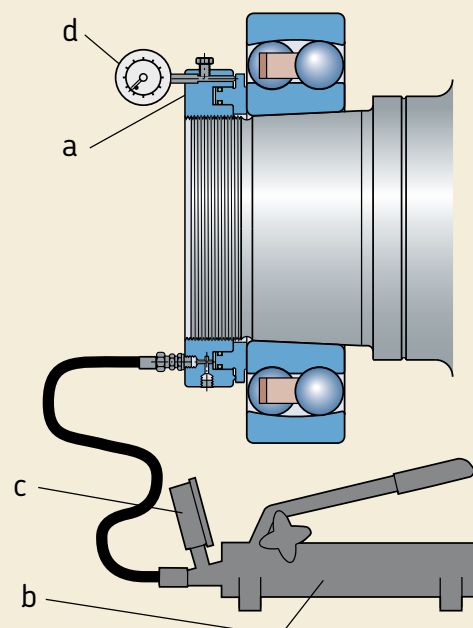

Fig. 16



Self-aligning ball bearings

Applying the SKF Drive-up Method, the bearing is pushed up its seating to a defined starting position (→ **fig. 17**) using a given oil pressure (corresponding to a given drive-up force) in the hydraulic nut. In this way, part of the desired reduction in radial internal clearance is achieved. The oil pressure is monitored by the pressure gauge. The bearing is then driven up from the defined starting position through a given distance to its final position. The axial displacement " s_s " is accurately determined using the dial gauge mounted on the hydraulic nut.

SKF has determined values of the requisite oil pressure and the axial displacement for individual bearings. These values apply to bearing arrangements (→ **fig. 18**) with

- one sliding interface (**a** and **b**) or
- two sliding interfaces (**c**).

Additional mounting information

Additional information on mounting self-aligning ball bearings in general or with the aid of the SKF Drive-up Method can be found

- in the handbook "SKF Drive-up Method" on CD-ROM
- online at www.skf.com/mount.

Fig. 17

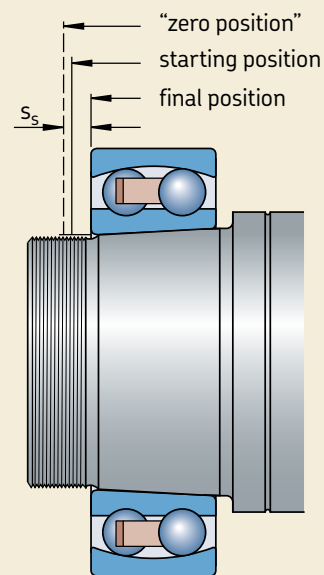
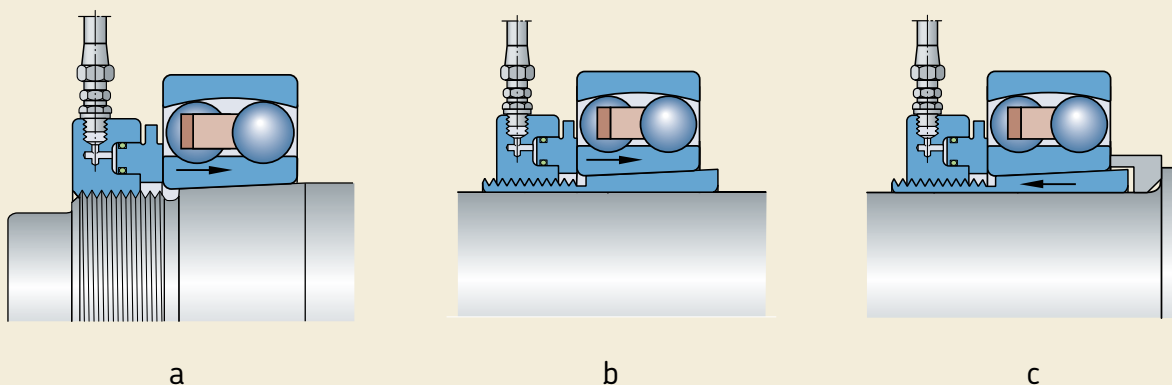
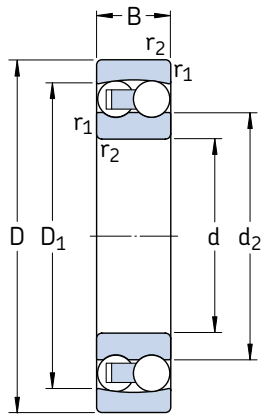

Fig. 18



Self-aligning ball bearings

d 5 – 25 mm



Cylindrical bore

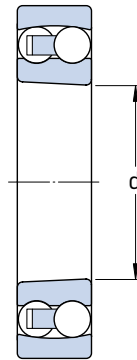

Tapered bore

Principal dimensions			Basic load ratings		Fatigue load limit P_u	Speed ratings		Mass	Designations	
d	D	B	dynamic C	static C_0		Refer- ence speed	Limiting speed		Bearing with cylindrical bore	tapered bore
mm			kN		kN	r/min		kg	–	
5	19	6	2,51	0,48	0,025	63 000	45 000	0,009	135 TN9	–
6	19	6	2,51	0,48	0,025	70 000	45 000	0,009	126 TN9	–
7	22	7	2,65	0,56	0,029	63 000	40 000	0,014	127 TN9	–
8	22	7	2,65	0,56	0,029	60 000	40 000	0,014	108 TN9	–
9	26	8	3,90	0,82	0,043	60 000	38 000	0,022	129 TN9	–
10	30	9	5,53	1,18	0,061	56 000	36 000	0,034	1200 ETN9	–
	30	14	8,06	1,73	0,090	50 000	34 000	0,047	2200 ETN9	–
12	32	10	6,24	1,43	0,072	50 000	32 000	0,040	1201 ETN9	–
	32	14	8,52	1,90	0,098	45 000	30 000	0,053	2201 ETN9	–
	37	12	9,36	2,16	0,12	40 000	28 000	0,067	1301 ETN9	–
	37	17	11,7	2,70	0,14	38 000	28 000	0,095	2301	–
15	35	11	7,41	1,76	0,09	45 000	28 000	0,049	1202 ETN9	–
	35	14	8,71	2,04	0,11	38 000	26 000	0,060	2202 ETN9	–
	42	13	10,8	2,60	0,14	34 000	24 000	0,094	1302 ETN9	–
	42	17	11,9	2,90	0,15	32 000	24 000	0,12	2302	–
17	40	12	8,84	2,20	0,12	38 000	24 000	0,073	1203 ETN9	–
	40	16	10,6	2,55	0,14	34 000	24 000	0,088	2203 ETN9	–
	47	14	12,7	3,40	0,18	28 000	20 000	0,12	1303 ETN9	–
	47	19	14,6	3,55	0,19	30 000	22 000	0,16	2303	–
20	47	14	12,7	3,4	0,18	32 000	20 000	0,12	1204 ETN9	1204 EKTN9
	47	18	16,8	4,15	0,22	28 000	20 000	0,14	2204 ETN9	–
	52	15	14,3	4	0,21	26 000	18 000	0,16	1304 ETN9	–
	52	21	18,2	4,75	0,24	26 000	19 000	0,22	2304 TN	–
25	52	15	14,3	4	0,21	28 000	18 000	0,14	1205 ETN9	1205 EKTN9
	52	18	16,8	4,4	0,23	26 000	18 000	0,16	2205 ETN9	2205 EKTN9
	62	17	19	5,4	0,28	22 000	15 000	0,26	1305 ETN9	1305 EKTN9
	62	24	27	7,1	0,37	22 000	16 000	0,34	2305 ETN9	–

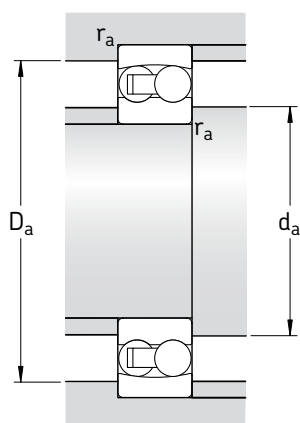

Dimensions				Abutment and fillet dimensions			Calculation factors			
d	d_2	D_1	$r_{1,2}$	d_a	D_a	r_a	e	Y_1	Y_2	Y_0
			min	min	max	max				
mm				mm			-			
5	10,3	15,4	0,3	7,4	16,6	0,3	0,33	1,9	3	2
6	10,3	15,4	0,3	8,4	16,6	0,3	0,33	1,9	3	2
7	12,6	17,6	0,3	9,4	19,6	0,3	0,33	1,9	3	2
8	12,6	17,6	0,3	10,4	19,6	0,3	0,33	1,9	3	2
9	14,8	21,1	0,3	11,4	23,6	0,3	0,33	1,9	3	2
10	16,7	24,4	0,6	14,2	25,8	0,6	0,33	1,9	3	2
	15,3	24,3	0,6	14,2	25,8	0,6	0,54	1,15	1,8	1,3
12	18,2	26,4	0,6	16,2	27,8	0,6	0,33	1,9	3	2
	17,5	26,5	0,6	16,2	27,8	0,6	0,50	1,25	2	1,3
	20	30,8	1	17,6	31,4	1	0,35	1,8	2,8	1,8
	18,6	31	1	17,6	31,4	1	0,60	1,05	1,6	1,1
15	21,2	29,6	0,6	19,2	30,8	0,6	0,33	1,9	3	2
	20,9	30,2	0,6	19,2	30,8	0,6	0,43	1,5	2,3	1,6
	23,9	35,3	1	20,6	36,4	1	0,31	2	3,1	2,2
	23,2	35,2	1	20,6	36,4	1	0,52	1,2	1,9	1,3
17	24	33,6	0,6	21,2	35,8	0,6	0,31	2	3,1	2,2
	23,8	34,1	0,6	21,2	35,8	0,6	0,43	1,5	2,3	1,6
	28,9	41	1	22,6	41,4	1	0,30	2,1	3,3	2,2
	25,8	39,4	1	22,6	41,4	1	0,52	1,2	1,9	1,3
20	28,9	41	1	25,6	41,4	1	0,30	2,1	3,3	2,2
	27,4	41	1	25,6	41,4	1	0,40	1,6	2,4	1,6
	33,3	45,6	1,1	27	45	1	0,28	2,2	3,5	2,5
	28,8	43,7	1,1	27	45	1	0,52	1,2	1,9	1,3
25	33,3	45,6	1	30,6	46,4	1	0,28	2,2	3,5	2,5
	32,3	46,1	1	30,6	46,4	1	0,35	1,8	2,8	1,8
	37,8	52,5	1,1	32	55	1	0,28	2,2	3,5	2,5
	35,5	53,5	1,1	32	55	1	0,44	1,4	2,2	1,4

Self-aligning ball bearings
d 30 – 65 mm

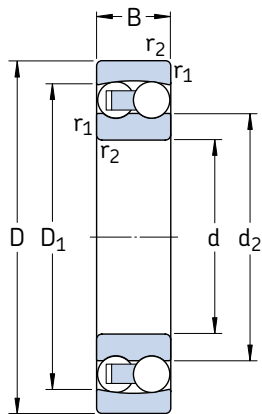

Cylindrical bore

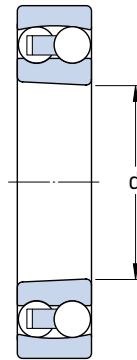

Tapered bore

Principal dimensions			Basic load ratings		Fatigue load limit P_u	Speed ratings		Mass	Designations	
d	D	B	C	C_0		Refer- ence speed	Limiting speed		Bearing with cylindrical bore	tapered bore
mm			kN		kN	r/min		kg	–	
30	62	16	15,6	4,65	0,24	24 000	15 000	0,22	1206 ETN9	1206 EKTN9
	62	20	23,8	6,7	0,35	22 000	15 000	0,26	2206 ETN9	2206 EKTN9
	72	19	22,5	6,8	0,36	19 000	13 000	0,39	1306 ETN9	1306 EKTN9
	72	27	31,2	8,8	0,45	18 000	13 000	0,50	2306	2306 K
35	72	17	19	6	0,31	20 000	13 000	0,32	1207 ETN9	1207 EKTN9
	72	23	30,7	8,8	0,46	18 000	12 000	0,40	2207 ETN9	2207 EKTN9
	80	21	26,5	8,5	0,43	16 000	11 000	0,51	1307 ETN9	1307 EKTN9
	80	31	39,7	11,2	0,59	16 000	12 000	0,68	2307 ETN9	2307 EKTN9
40	80	18	19,9	6,95	0,36	18 000	11 000	0,42	1208 ETN9	1208 EKTN9
	80	23	31,9	10	0,51	16 000	11 000	0,51	2208 ETN9	2208 EKTN9
	90	23	33,8	11,2	0,57	14 000	9 500	0,68	1308 ETN9	1308 EKTN9
	90	33	54	16	0,82	14 000	10 000	0,93	2308 ETN9	2308 EKTN9
45	85	19	22,9	7,8	0,40	17 000	11 000	0,47	1209 ETN9	1209 EKTN9
	85	23	32,5	10,6	0,54	15 000	10 000	0,55	2209 ETN9	2209 EKTN9
	100	25	39	13,4	0,70	12 000	8 500	0,96	1309 ETN9	1309 EKTN9
	100	36	63,7	19,3	1	13 000	9 000	1,25	2309 ETN9	2309 EKTN9
50	90	20	26,5	9,15	0,48	16 000	10 000	0,53	1210 ETN9	1210 EKTN9
	90	23	33,8	11,2	0,57	14 000	9 500	0,60	2210 ETN9	2210 EKTN9
	110	27	43,6	14	0,72	12 000	8 000	1,20	1310 ETN9	1310 EKTN9
	110	40	63,7	20	1,04	14 000	9 500	1,65	2310	2310 K
55	100	21	27,6	10,6	0,54	14 000	9 000	0,71	1211 ETN9	1211 EKTN9
	100	25	39	13,4	0,70	12 000	8 500	0,81	2211 ETN9	2211 EKTN9
	120	29	50,7	18	0,92	11 000	7 500	1,60	1311 ETN9	1311 EKTN9
	120	43	76,1	24	1,25	11 000	7 500	2,10	2311	2311 K
60	110	22	31,2	12,2	0,62	12 000	8 500	0,90	1212 ETN9	1212 EKTN9
	110	28	48,8	17	0,88	11 000	8 000	1,10	2212 ETN9	2212 EKTN9
	130	31	58,5	22	1,12	9 000	6 300	1,95	1312 ETN9	1312 EKTN9
	130	46	87,1	28,5	1,46	9 500	7 000	2,60	2312	2312 K
65	120	23	35,1	14	0,72	11 000	7 000	1,15	1213 ETN9	1213 EKTN9
	120	31	57,2	20	1,02	10 000	7 000	1,45	2213 ETN9	2213 EKTN9
	140	33	65	25,5	1,25	8 500	6 000	2,45	1313 ETN9	1313 EKTN9
	140	48	95,6	32,5	1,66	9 000	6 300	3,25	2313	2313 K

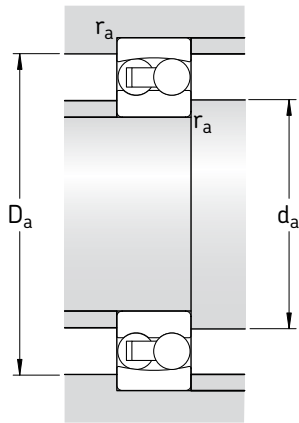

Dimensions				Abutment and fillet dimensions			Calculation factors			
d	d ₂	D ₁	r _{1,2}	d _a	D _a	r _a	e	Y ₁	Y ₂	Y ₀
				min						
				max						
mm				mm			-			
30	40,1	53	1	35,6	56,4	1	0,25	2,5	3,9	2,5
	38,8	55	1	35,6	56,4	1	0,33	1,9	3	2
	44,9	60,9	1,1	37	65	1	0,25	2,5	3,9	2,5
	41,7	60,9	1,1	37	65	1	0,44	1,4	2,2	1,4
35	47	62,3	1,1	42	65	1	0,23	2,7	4,2	2,8
	45,3	64,2	1,1	42	65	1	0,31	2	3,1	2,2
	51,5	69,5	1,5	44	71	1,5	0,25	2,5	3,9	2,5
	46,5	68,4	1,5	44	71	1,5	0,46	1,35	2,1	1,4
40	53,6	68,8	1,1	47	73	1	0,22	2,9	4,5	2,8
	52,4	71,6	1,1	47	73	1	0,28	2,2	3,5	2,5
	61,5	81,5	1,5	49	81	1,5	0,23	2,7	4,2	2,8
	53,7	79,2	1,5	49	81	1,5	0,40	1,6	2,4	1,6
45	57,5	73,7	1,1	52	78	1	0,21	3	4,6	3,2
	55,3	74,6	1,1	52	78	1	0,26	2,4	3,7	2,5
	67,7	89,5	1,5	54	91	1,5	0,23	2,7	4,2	2,8
	60,1	87,4	1,5	54	91	1,5	0,33	1,9	3	2
50	61,7	79,5	1,1	57	83	1	0,21	3	4,6	3,2
	61,5	81,5	1,1	57	83	1	0,23	2,7	4,2	2,8
	70,3	95	2	61	99	2	0,24	2,6	4,1	2,8
	65,8	94,4	2	61	99	2	0,43	1,5	2,3	1,6
55	70,1	88,4	1,5	64	91	1,5	0,19	3,3	5,1	3,6
	67,7	89,5	1,5	64	91	1,5	0,23	2,7	4,2	2,8
	77,7	104	2	66	109	2	0,23	2,7	4,2	2,8
	72	103	2	66	109	2	0,40	1,6	2,4	1,6
60	78	97,6	1,5	69	101	1,5	0,19	3,3	5,1	3,6
	74,5	98,6	1,5	69	101	1,5	0,24	2,6	4,1	2,8
	91,6	118	2,1	72	118	2	0,22	2,9	4,5	2,8
	76,9	112	2,1	72	118	2	0,33	1,9	3	2
65	85,3	106	1,5	74	111	1,5	0,18	3,5	5,4	3,6
	80,7	107	1,5	74	111	1,5	0,24	2,6	4,1	2,8
	99	127	2,1	77	128	2	0,22	2,9	4,5	2,8
	85,5	122	2,1	77	128	2	0,37	1,7	2,6	1,8

Self-aligning ball bearings

d 70 – 120 mm

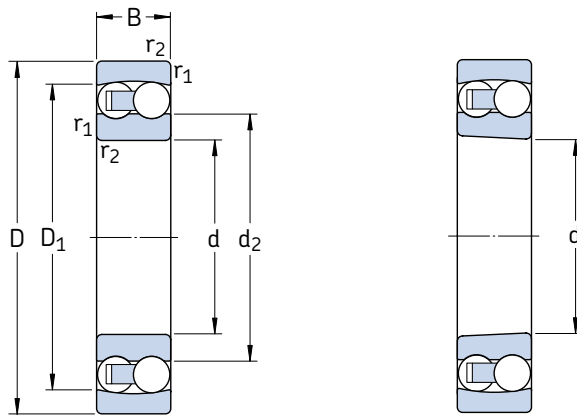

Cylindrical bore

Tapered bore

Principal dimensions			Basic load ratings		Fatigue load limit P_u	Speed ratings		Mass	Designations	
d	D	B	C	C_0		Reference speed	Limiting speed		Bearing with cylindrical bore	tapered bore
mm			kN		kN	r/min		kg	–	
70	125	24	35,8	14,6	0,75	11 000	7 000	1,25	1214 ETN9	–
	125	31	44,2	17	0,88	10 000	6 700	1,50	2214	–
	150	35	74,1	27,5	1,34	8 500	6 000	3,00	1314	–
	150	51	111	37,5	1,86	8 000	6 000	3,90	2314	–
75	130	25	39	15,6	0,80	10 000	6 700	1,35	1215	1215 K
	130	31	58,5	22	1,12	9 000	6 300	1,60	2215 ETN9	2215 EKTN9
	160	37	79,3	30	1,43	8 000	5 600	3,55	1315	1315 K
	160	55	124	43	2,04	7 500	5 600	4,70	2315	2315 K
80	140	26	39,7	17	0,83	9 500	6 000	1,65	1216	1216 K
	140	33	65	25,5	1,25	8 500	6 000	2,00	2216 ETN9	2216 EKTN9
	170	39	88,4	33,5	1,50	7 500	5 300	4,20	1316	1316 K
	170	58	135	49	2,24	7 000	5 300	6,10	2316	2316 K
85	150	28	48,8	20,8	0,98	9 000	5 600	2,05	1217	1217 K
	150	36	58,5	23,6	1,12	8 000	5 600	2,50	2217	2217 K
	180	41	97,5	38	1,70	7 000	4 800	5,00	1317	1317 K
	180	60	140	51	2,28	6 700	4 800	7,05	2317	2317 K
90	160	30	57,2	23,6	1,08	8 500	5 300	2,50	1218	1218 K
	160	40	70,2	28,5	1,32	7 500	5 300	3,40	2218	2218 K
	190	43	117	44	1,93	6 700	4 500	5,80	1318	1318 K
	190	64	153	57	2,50	6 300	4 500	8,45	2318 M	2318 KM
95	170	32	63,7	27	1,20	8 000	5 000	3,10	1219	1219 K
	170	43	83,2	34,5	1,53	7 000	5 000	4,10	2219 M	2219 KM
	200	45	133	51	2,16	6 300	4 300	6,70	1319	1319 K
	200	67	165	64	2,75	6 000	4 500	9,80	2319 M	–
100	180	34	68,9	30	1,29	7 500	4 800	3,70	1220	1220 K
	180	46	97,5	40,5	1,76	6 700	4 800	5,00	2220 M	2220 KM
	215	47	143	57	2,36	6 000	4 000	8,30	1320	1320 K
	215	73	190	80	3,25	5 600	4 000	12,5	2320 M	2320 KM
110	200	38	88,4	39	1,60	6 700	4 300	5,15	1222	1222 K
	200	53	124	52	2,12	6 000	4 300	7,10	2222 M	2222 KM
	240	50	163	72	2,75	5 300	3 600	12,0	1322 M	1322 KM
120	215	42	119	53	2,12	6 300	4 000	6,75	1224 M	1224 KM

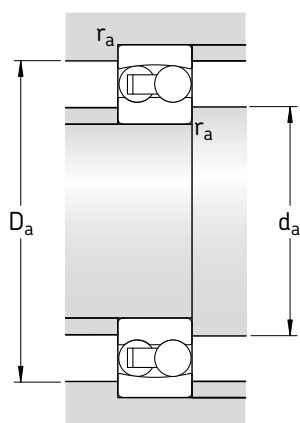

Dimensions				Abutment and fillet dimensions			Calculation factors			
d	d_2 ~	D_1 ~	$r_{1,2}$ min	d_a min	D_a max	r_a max	e	Y_1	Y_2	Y_0
mm				mm			-			
70	87,4	109	1,5	79	116	1,5	0,18	3,5	5,4	3,6
	87,5	111	1,5	79	116	1,5	0,27	2,3	3,6	2,5
	97,7	129	2,1	82	138	2	0,22	2,9	4,5	2,8
	91,6	130	2,1	82	138	2	0,37	1,7	2,6	1,8
75	93	116	1,5	84	121	1,5	0,17	3,7	5,7	4
	91,6	118	1,5	84	121	1,5	0,22	2,9	4,5	2,8
	104	138	2,1	87	148	2	0,22	2,9	4,5	2,8
	97,8	139	2,1	87	148	2	0,37	1,7	2,6	1,8
80	101	125	2	91	129	2	0,16	3,9	6,1	4
	99	127	2	91	129	2	0,22	2,9	4,5	2,8
	109	147	2,1	92	158	2	0,22	2,9	4,5	2,8
	104	148	2,1	92	158	2	0,37	1,7	2,6	1,8
85	107	134	2	96	139	2	0,17	3,7	5,7	4
	105	133	2	96	139	2	0,25	2,5	3,9	2,5
	117	155	3	99	166	2,5	0,22	2,9	4,5	2,8
	115	157	3	99	166	2,5	0,37	1,7	2,6	1,8
90	112	142	2	101	149	2	0,17	3,7	5,7	4
	112	142	2	101	149	2	0,27	2,3	3,6	2,5
	122	165	3	104	176	2,5	0,22	2,9	4,5	2,8
	121	164	3	104	176	2,5	0,37	1,7	2,6	1,8
95	120	151	2,1	107	158	2	0,17	3,7	5,7	4
	118	151	2,1	107	158	2	0,27	2,3	3,6	2,5
	127	174	3	109	186	2,5	0,23	2,7	4,2	2,8
	128	172	3	109	186	2,5	0,37	1,7	2,6	1,8
100	127	159	2,1	112	168	2	0,17	3,7	5,7	4
	124	160	2,1	112	168	2	0,27	2,3	3,6	2,5
	136	185	3	114	201	2,5	0,23	2,7	4,2	2,8
	135	186	3	114	201	2,5	0,37	1,7	2,6	1,8
110	140	176	2,1	122	188	2	0,17	3,7	5,7	4
	137	177	2,1	122	188	2	0,28	2,2	3,5	2,5
	154	206	3	124	226	2,5	0,22	2,9	4,5	2,8
120	149	190	2,1	132	203	2	0,19	3,3	5,1	3,6

Self-aligning ball bearings
d 130 – 240 mm

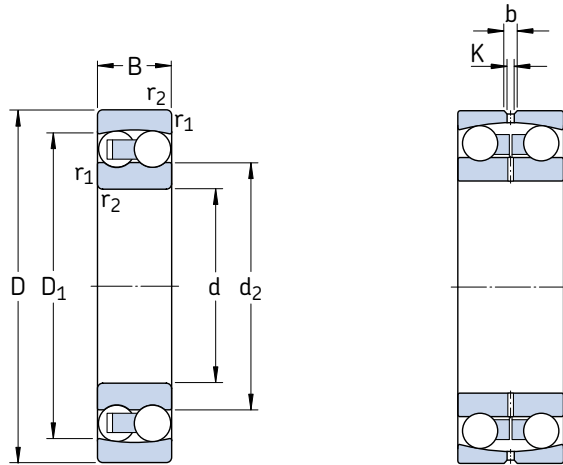

Principal dimensions			Basic load ratings		Fatigue load limit P_u	Speed ratings		Mass	Designation
d	D	B	dynamic C	static C_0		Refer- ence speed	Limiting speed		
mm			kN		kN	r/min		kg	–
130	230	46	127	58,5	2,24	5 600	3 600	8,30	1226 M
150	225	56	57,2	23,6	0,88	5 600	3 400	7,50	13030
180	280	74	95,6	40	1,34	4 500	2 800	16,0	13036
200	280	60	60,5	29	0,97	4 300	2 600	10,7	13940
220	300	60	60,5	30,5	0,97	3 800	2 400	11,0	13944
240	320	60	60,5	32	0,98	3 800	2 200	11,3	13948

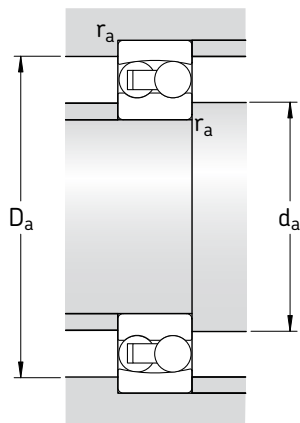

Dimensions						Abutment and fillet dimensions			Calculation factors			
d	d_2 ~	D_1 ~	b	K	$r_{1,2}$ min	d_a min	D_a max	r_a max	e	Y_1	Y_2	Y_0
mm						mm			-			
130	163	204	-	-	3	144	216	2,5	0,19	3,3	5,1	3,6
150	175	203	8,3	4,5	2,1	161	214	2	0,24	2,6	4,1	2,8
180	212	249	13,9	7,5	2,1	191	269	2	0,25	2,5	3,9	2,5
200	229	258	8,3	4,5	2,1	211	269	2	0,19	3,3	5,1	3,6
220	249	278	8,3	4,5	2,1	231	289	2	0,18	3,5	5,4	3,6
240	269	298	8,3	4,5	2,1	251	309	2	0,16	3,9	6,1	4

Sealed self-aligning ball bearings d 10 – 70 mm

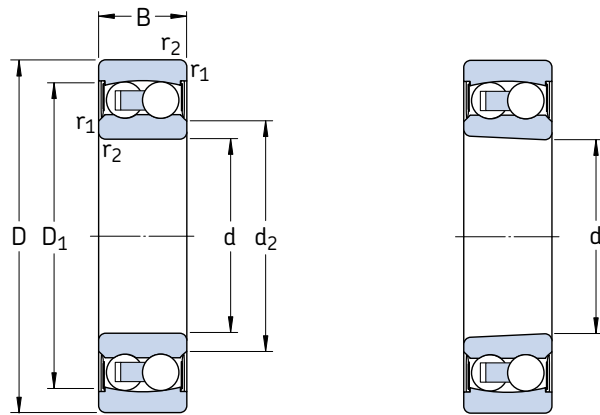

Cylindrical bore

Tapered bore

Principal dimensions			Basic load ratings		Fatigue load limit P_u	Limiting speed	Mass	Designations Bearing with cylindrical bore	tapered bore
d	D	B	C	C_0					
mm			kN		kN	r/min	kg	–	
10	30	14	5,53	1,18	0,06	17 000	0,048	2200 E-2RS1TN9	–
12	32	14	6,24	1,43	0,08	16 000	0,053	2201 E-2RS1TN9	–
15	35	14	7,41	1,76	0,09	14 000	0,058	2202 E-2RS1TN9	–
	42	17	10,8	2,6	0,14	12 000	0,11	2302 E-2RS1TN9	–
17	40	16	8,84	2,2	0,12	12 000	0,089	2203 E-2RS1TN9	–
	47	19	12,7	3,4	0,18	11 000	0,16	2303 E-2RS1TN9	–
20	47	18	12,7	3,4	0,18	10 000	0,14	2204 E-2RS1TN9	–
	52	21	14,3	4	0,21	9 000	0,21	2304 E-2RS1TN9	–
25	52	18	14,3	4	0,21	9 000	0,16	2205 E-2RS1TN9	2205 E-2RS1KTN9
	62	24	19	5,4	0,28	7 500	0,34	2305 E-2RS1TN9	–
30	62	20	15,6	4,65	0,24	7 500	0,26	2206 E-2RS1TN9	2206 E-2RS1KTN9
	72	27	22,5	6,8	0,36	6 700	0,51	2306 E-2RS1TN9	–
35	72	23	19	6	0,31	6 300	0,41	2207 E-2RS1TN9	2207 E-2RS1KTN9
	80	31	26,5	8,5	0,43	5 600	0,70	2307 E-2RS1TN9	–
40	80	23	19,9	6,95	0,36	5 600	0,50	2208 E-2RS1TN9	2208 E-2RS1KTN9
	90	33	33,8	11,2	0,57	5 000	0,96	2308 E-2RS1TN9	–
45	85	23	22,9	7,8	0,40	5 300	0,53	2209 E-2RS1TN9	2209 E-2RS1KTN9
	100	36	39	13,4	0,70	4 500	1,30	2309 E-2RS1TN9	–
50	90	23	22,9	8,15	0,42	4 800	0,57	2210 E-2RS1TN9	2210 E-2RS1KTN9
	110	40	43,6	14	0,72	4 000	1,65	2310 E-2RS1TN9	–
55	100	25	27,6	10,6	0,54	4 300	0,79	2211 E-2RS1TN9	2211 E-2RS1KTN9
60	110	28	31,2	12,2	0,62	3 800	1,05	2212 E-2RS1TN9	2212 E-2RS1KTN9
65	120	31	35,1	14	0,72	3 600	1,40	2213 E-2RS1TN9	2213 E-2RS1KTN9
70	125	31	35,8	14,6	0,75	3 400	1,45	2214 E-2RS1TN9	–

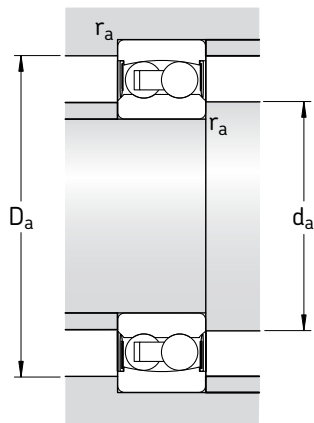

Dimensions				Abutment and fillet dimensions				Calculation factors			
d	d ₂	D ₁	r _{1,2} min	d _a min	d _a max	D _a max	r _a max	e	Y ₁	Y ₂	Y ₀
mm				mm				-			
10	14	24,8	0,6	14	14	25,8	0,6	0,33	1,9	3	2
12	15,5	27,4	0,6	15,5	15,5	27,8	0,6	0,33	1,9	3	2
15	19,1 20,3	30,4 36,3	0,6 1	19 20	19 20	30,8 36,4	0,6 1	0,33 0,31	1,9 2	3 3,1	2 2,2
17	21,1 25,5	35 41,3	0,6 1	21 22	21 25,5	35,8 41,4	0,6 1	0,31 0,30	2 2,1	3,1 3,3	2,2 2,2
20	25,9 28,6	41,3 46,3	1 1,1	25 26,5	25,5 28,5	41,4 45	1 1	0,30 0,28	2,1 2,2	3,3 3,5	2,2 2,5
25	31 32,8	46,3 52,7	1 1,1	30,6 32	31 32,5	46,4 55	1 1	0,28 0,28	2,2 2,2	3,5 3,5	2,5 2,5
30	36,7 40,4	54,1 61,9	1 1,1	35,6 37	36,5 40	56,4 65	1 1	0,25 0,25	2,5 2,5	3,9 3,9	2,5 2,5
35	42,7 43,7	62,7 69,2	1,1 1,5	42 43,5	42,5 43,5	65 71	1 1,5	0,23 0,25	2,7 2,5	4,2 3,9	2,8 2,5
40	49 55,4	69,8 81,8	1,1 1,5	47 49	49 55	73 81	1 1,5	0,22 0,23	2,9 2,7	4,5 4,2	2,8 2,8
45	53,1 60,9	75,3 90	1,1 1,5	52 54	53 60,5	78 91	1 1,5	0,21 0,23	3 2,7	4,6 4,2	3,2 2,8
50	58,1 62,9	79,5 95,2	1,1 2	57 61	58 62,5	83 99	1 2	0,20 0,24	3,2 2,6	4,9 4,1	3,2 2,8
55	65,9	88,5	1,5	64	65,5	91	1,5	0,19	3,3	5,1	3,6
60	73,2	97	1,5	69	73	101	1,5	0,19	3,3	5,1	3,6
65	79,3	106	1,5	74	79	111	1,5	0,18	3,5	5,4	3,6
70	81,4	109	1,5	79	81	116	1,5	0,18	3,5	5,4	3,6

Self-aligning ball bearings with extended inner ring
d 20 – 60 mm

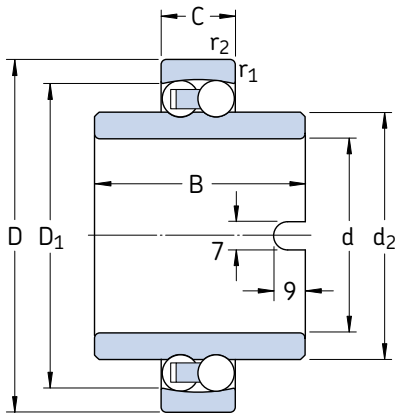

Principal dimensions			Basic load ratings		Fatigue load limit P_u	Limiting speed	Mass	Designation
d	D	C	dynamic C	static C_0				
mm			kN		kN	r/min	kg	–
20	47	14	12,7	3,4	0,18	9 000	0,18	11204 ETN9
25	52	15	14,3	4	0,21	8 000	0,22	11205 ETN9
30	62	16	15,6	4,65	0,24	6 700	0,35	11206 TN9
35	72	17	15,9	5,1	0,27	5 600	0,54	11207 TN9
40	80	18	19	6,55	0,34	5 000	0,72	11208 TN9
45	85	19	21,6	7,35	0,38	4 500	0,77	11209 TN9
50	90	20	22,9	8,15	0,42	4 300	0,85	11210 TN9
60	110	22	30,2	11,6	0,60	3 400	1,15	11212 TN9

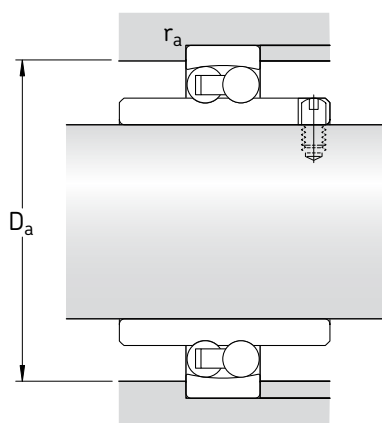

Dimensions					Abutment and fillet dimensions		Calculation factors			
d	d_2	D_1	B	$r_{1,2}$ min	D_a max	r_a max	e	Y_1	Y_2	Y_0
mm					mm		-			
20	28,9	41	40	1	41,4	1	0,30	2,1	3,3	2,2
25	33,3	45,6	44	1	46,4	1	0,28	2,2	3,5	2,5
30	40,1	53,2	48	1	56,4	1	0,25	2,5	3,9	2,5
35	47,7	60,7	52	1,1	65	1	0,23	2,7	4,2	2,8
40	54	68,8	56	1,1	73	1	0,22	2,9	4,5	2,8
45	57,7	73,7	58	1,1	78	1	0,21	3	4,6	3,2
50	62,7	78,7	58	1,1	83	1	0,21	3	4,6	3,2
60	78	97,5	62	1,5	101	1,5	0,19	3,3	5,1	3,6

Self-aligning ball bearings on adapter sleeve

d_1 17 – 45 mm

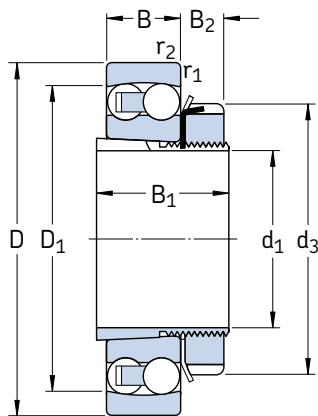

Open bearing

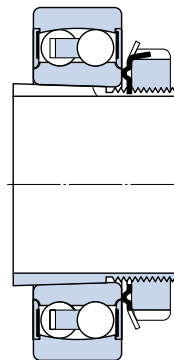

Sealed bearing

Principal dimensions			Basic load ratings		Fatigue load limit P_u	Speed ratings		Mass Bearing + sleeve	Designations Bearing	Adapter sleeve
d_1	D	B	C	C_0		Refer-ence speed	Limiting speed			
mm			kN		kN	r/min	kg	–		
17	47	14	12,7	3,4	0,18	32 000	20 000	0,16	1204 EKTN9	H 204
20	52	15	14,3	4	0,21	28 000	18 000	0,21	1205 EKTN9	H 205
	52	18	16,8	4,4	0,23	26 000	18 000	0,23	2205 EKTN9	H 305
	52	18	14,3	4	0,21	–	9 000	0,23	2205 E-2RS1KTN9	H 305 C
	62	17	19	5,4	0,28	22 000	15 000	0,33	1305 EKTN9	H 305
25	62	16	15,6	4,65	0,24	24 000	15 000	0,32	▶ 1206 EKTN9	H 206
	62	20	23,8	6,7	0,35	22 000	15 000	0,36	2206 EKTN9	H 306
	62	20	15,6	4,65	0,24	–	7 500	0,36	2206 E-2RS1KTN9	H 306 C
	72	19	22,5	6,8	0,36	19 000	13 000	0,49	1306 EKTN9	H 306
	72	27	31,2	8,8	0,45	18 000	13 000	0,61	2306 K	H 2306
30	72	17	19	6	0,31	20 000	13 000	0,44	▶ 1207 EKTN9	H 207
	72	23	30,7	8,8	0,46	18 000	12 000	0,54	2207 EKTN9	H 307
	72	23	19	6	0,31	–	6 300	0,55	2207 E-2RS1KTN9	H 307 C
	80	21	26,5	8,5	0,43	16 000	11 000	0,65	1307 EKTN9	H 307
	80	31	39,7	11,2	0,59	18 000	12 000	0,84	2307 EKTN9	H 2307
35	80	18	19,9	6,95	0,36	18 000	11 000	0,58	▶ 1208 EKTN9	H 208
	80	23	31,9	10	0,51	16 000	11 000	0,58	2208 EKTN9	H 308
	80	23	19,9	6,95	0,36	–	5 600	0,67	2208 E-2RS1KTN9	H 308 C
	90	23	33,8	11,2	0,57	14 000	9 500	0,85	1308 EKTN9	H 308
	90	33	54	16	0,82	14 000	10 000	1,10	2308 EKTN9	H 2308
40	85	19	22,9	7,8	0,40	17 000	11 000	0,68	▶ 1209 EKTN9	H 209
	85	23	32,5	10,6	0,54	15 000	10 000	0,78	2209 EKTN9	H 309
	85	23	22,9	7,8	0,40	–	5 300	0,76	2209 E-2RS1KTN9	H 309 C
	100	25	39	13,4	0,70	12 000	8 500	1,20	1309 EKTN9	H 309
	100	36	63,7	19,3	1	13 000	9 000	1,40	2309 EKTN9	H 2309
45	90	20	26,5	9,15	0,48	16 000	10 000	0,77	▶ 1210 EKTN9	H 210
	90	23	33,8	11,2	0,57	14 000	9 500	0,87	2210 EKTN9	H 310
	90	23	22,9	8,15	0,42	–	4 800	0,84	2210 E-2RS1KTN9	H 310 C
	110	27	43,6	14	0,72	12 000	8 000	1,45	1310 EKTN9	H 310
	110	40	63,7	20	1,04	14 000	9 500	1,90	2310 K	H 2310

▶ Bearings and sleeves also available as KAM self-aligning ball bearing kits (→ page 474)

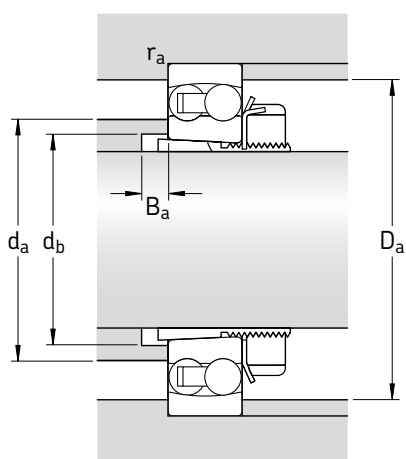

Dimensions						Abutment and fillet dimensions					Calculation factors			
d_1	d_3	D_1	B_1	B_2	$r_{1,2}$	d_a	d_b	D_a	B_a	r_a	e	Y_1	Y_2	Y_0
						mm					-			
17	32	41	24	7	1	28,5	23	41,4	5	1	0,30	2,1	3,3	2,2
20	38	45,6	26	8	1	33	28	46,4	5	1	0,28	2,2	3,5	2,5
	38	46,1	29	8	1	32	28	46,4	5	1	0,35	1,8	2,8	1,8
	38	46,3	29	9	1	31	28	46,4	5	1	0,28	2,2	3,5	2,5
	38	52,5	29	8	1,1	37	28	55	6	1	0,28	2,2	3,5	2,5
25	45	53	27	8	1	40	33	56,4	5	1	0,25	2,5	3,9	2,5
	45	55	31	8	1	38	33	56,4	5	1	0,33	1,9	3	2
	45	54,1	31	9	1	36	33	56,4	5	1	0,25	2,5	3,9	2,5
	45	60,9	27	8	1,1	44	33	65	6	1	0,25	2,5	3,9	2,5
	45	60,9	38	8	1,1	41	35	65	5	1	0,44	1,4	2,2	1,4
30	52	62,3	29	9	1,1	47	38	65	-	1	0,23	2,7	4,2	2,8
	52	64,2	35	9	1,1	45	39	65	5	1	0,31	2	3,1	2,2
	52	62,7	35	10	1,1	42	39	65	5	1	0,23	2,7	4,2	2,8
	52	69,5	35	9	1,5	51	39	71	7	1,5	0,25	2,5	3,9	2,5
	52	68,4	43	9	1,5	46	40	71	5	1,5	0,46	1,35	2,1	1,4
35	58	68,8	31	10	1,1	53	43	73	6	1	0,22	2,9	4,5	2,8
	58	71,6	36	10	1,1	52	44	73	6	1	0,28	2,2	3,5	2,5
	58	69,8	36	11	1,1	49	44	73	6	1	0,22	2,9	4,5	2,8
	58	81,5	36	10	1,5	61	44	81	6	1,5	0,23	2,7	4,2	2,8
	58	79,2	46	10	1,5	53	45	81	6	1,5	0,40	1,6	2,4	1,6
40	65	73,7	33	11	1,1	57	48	78	6	1	0,21	3	4,6	3,2
	65	74,6	39	11	1,1	55	50	78	8	1	0,26	2,4	3,7	2,5
	65	75,3	39	12	1,1	53	50	78	8	1	0,21	3	4,6	3,2
	65	89,5	39	11	1,5	67	50	91	6	1,5	0,23	2,7	4,2	2,8
	65	87,4	50	11	1,5	60	50	91	6	1,5	0,33	1,9	3	2
	65	87,4	50	11	1,5	60	50	91	6	1,5	0,33	1,9	3	2
45	70	79,5	35	12	1,1	62	53	83	6	1	0,21	3	4,6	3,2
	70	81,5	42	12	1,1	61	55	83	10	1	0,23	2,7	4,2	2,8
	70	79,5	42	13	1,1	58	55	83	10	1	0,20	3,2	4,9	3,2
	70	95	42	12	2	70	55	99	6	2	0,24	2,6	4,1	2,8
	70	94,4	55	12	2	65	56	99	6	2	0,43	1,5	2,3	1,6
	70	94,4	55	12	2	65	56	99	6	2	0,43	1,5	2,3	1,6

Self-aligning ball bearings on adapter sleeve

d_1 50 – 80 mm

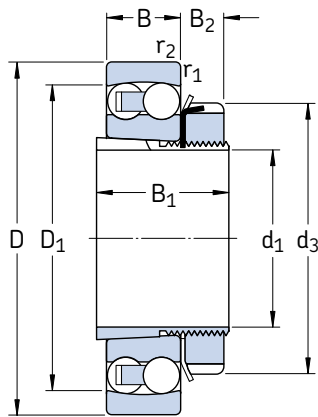

Open bearing

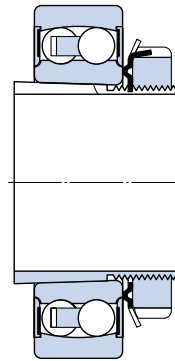

Sealed bearing

Principal dimensions			Basic load ratings		Fatigue load limit P_u	Speed ratings		Mass Bearing + sleeve	Designations Bearing	Adapter sleeve
d_1	D	B	C	C_0		Refer-ence speed	Limiting speed			
mm			kN		kN	r/min	kg	–		
50	100	21	27,6	10,6	0,54	14 000	9 000	0,99	▶ 1211 EKTN9 2211 EKTN9 2211 E-2RS1KTN9 1311 EKTN9 2311 K	H 211
	100	25	39	13,4	0,70	12 000	8 500	1,15		H 311
	100	25	27,6	10,6	0,54	–	4 300	1,10		H 311 C
	120	29	50,7	18	0,92	11 000	7 500	1,90		H 311
	120	43	76,1	24	1,25	11 000	7 500	2,40		H 2311
55	110	22	31,2	12,2	0,62	12 000	8 500	1,20	1212 EKTN9	H 212
	110	28	48,8	17	0,88	11 000	8 000	1,45	2212 EKTN9	H 312
	110	28	31,2	12,2	0,62	–	3 800	1,40	2212 E-2RS1KTN9	H 312 C
	130	31	58,5	22	1,12	9 000	6 300	2,15	1312 EKTN9	H 312
	130	46	87,1	28,5	1,46	9 500	7 000	2,95	2312 K	H 2312
60	120	23	35,1	14	0,72	11 000	7 000	1,45	1213 EKTN9	H 213
	120	31	57,2	20	1,02	10 000	7 000	1,80	2213 EKTN9	H 313
	120	31	35,1	14	0,72	–	3 600	1,75	2213 E-2RS1KTN9	H 313 C
	140	33	65	25,5	1,25	8 500	6 000	2,85	1313 EKTN9	H 313
	140	48	95,6	32,5	1,66	9 000	6 300	3,60	2313 K	H 2313
65	130	25	39	15,6	0,80	10 000	6 700	2,00	1215 K	H 215
	130	31	58,5	22	1,12	9 000	6 300	2,30	2215 EKTN9	H 315
	160	37	79,3	30	1,43	8 000	5 600	4,20	1315 K	H 315
	160	55	124	43	2,04	7 500	5 600	5,55	2315 K	H 2315
70	140	26	39,7	17	0,83	9 500	6 000	2,40	1216 K	H 216
	140	33	65	25,5	1,25	8 500	6 000	2,85	2216 EKTN9	H 316
	170	39	88,4	33,5	1,50	7 500	5 300	5,00	1316 K	H 316
	170	58	135	49	2,24	7 000	5 300	7,10	2316 K	H 2316
75	150	28	48,8	20,8	0,98	9 000	5 600	2,95	1217 K	H 217
	150	36	58,5	23,6	1,12	8 000	5 600	3,30	2217 K	H 317
	180	41	97,5	38	1,70	7 000	4 800	6,00	1317 K	H 317
	180	60	140	51	2,28	6 700	4 800	8,15	2317 K	H 2317
80	160	30	57,2	23,6	1,08	8 500	5 300	3,50	1218 K	H 218
	160	40	70,2	28,5	1,32	7 500	5 300	5,50	2218 K	H 318
	190	43	117	44	1,93	6 700	4 500	6,90	1318 K	H 318
	190	64	153	57	2,50	6 300	4 500	9,80	2318 KM	H 2318

▶ Bearings and sleeves also available as KAM self-aligning ball bearing kits (→ page 474)

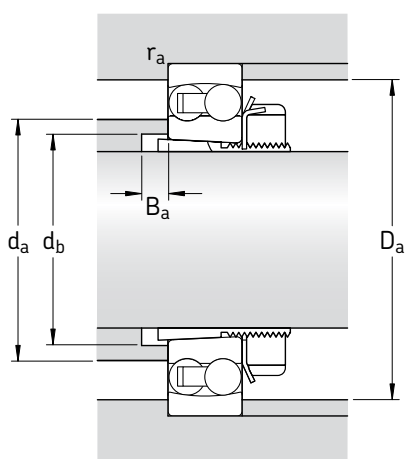

Dimensions						Abutment and fillet dimensions					Calculation factors			
d_1	d_3	D_1	B_1	B_2	$r_{1,2}$ min	d_a max	d_b min	D_a max	B_a min	r_a max	e	Y_1	Y_2	Y_0
mm						mm					-			
50	75	88,4	37	12,5	1,5	70	60	91	7	1,5	0,19	3,3	5,1	3,6
	75	89,5	45	12,5	1,5	67	60	91	11	1,5	0,23	2,7	4,2	2,8
	75	88,5	45	13	1,5	65	60	91	11	1,5	0,19	3,3	5,1	3,6
	75	104	45	12,5	2	77	60	109	7	2	0,23	2,7	4,2	2,8
	75	103	59	12,5	2	72	61	109	7	2	0,40	1,6	2,4	1,6
55	80	97,6	38	12,5	1,5	78	64	101	7	1,5	0,19	3,3	5,1	3,6
	80	98,6	47	12,5	1,5	74	65	101	9	1,5	0,24	2,6	4,1	2,8
	80	97	47	13,5	1,5	73	65	101	9	1,5	0,19	3,3	5,1	3,6
	80	118	47	12,5	2,1	87	65	118	7	2	0,22	2,9	4,5	2,8
	80	112	62	12,5	2,1	76	66	118	7	2	0,33	1,9	3	2
60	85	106	40	13,5	1,5	85	70	111	7	1,5	0,18	3,5	5,4	3,6
	85	107	50	13,5	1,5	80	70	111	9	1,5	0,24	2,6	4,1	2,8
	85	106	50	14,5	1,5	79	70	111	7	1,5	0,18	3,5	5,4	3,6
	85	127	50	13,5	2,1	89	70	128	7	2	0,22	2,9	4,5	2,8
	85	122	65	13,5	2,1	85	72	128	7	2	0,37	1,7	2,6	1,8
65	98	116	43	14,5	1,5	93	80	121	7	1,5	0,17	3,7	5,7	4
	98	118	55	14,5	1,5	93	80	121	13	1,5	0,22	2,9	4,5	2,8
	98	138	55	14,5	2,1	104	80	148	7	2	0,22	2,9	4,5	2,8
	98	139	73	14,5	2,1	97	82	148	7	2	0,37	1,7	2,6	1,8
70	105	125	46	17	2	101	85	129	7	2	0,16	3,9	6,1	4
	105	127	59	17	2	99	85	129	13	2	0,22	2,9	4,5	2,8
	105	147	59	17	2,1	109	85	158	7	2	0,22	2,9	4,5	2,8
	105	148	78	17	2,1	104	88	158	7	2	0,37	1,7	2,6	1,8
75	110	134	50	18	2	107	90	139	8	2	0,17	3,7	5,7	4
	110	133	63	18	2	105	91	139	13	2	0,25	2,5	3,9	2,5
	110	155	63	18	3	117	91	166	8	2,5	0,22	2,9	4,5	2,8
	110	157	82	18	3	111	94	166	8	2,5	0,37	1,7	2,6	1,8
80	120	142	52	18	2	112	95	149	8	2	0,17	3,7	5,7	4
	120	142	65	18	2	112	96	149	11	2	0,27	2,3	3,6	2,5
	120	165	65	18	3	122	96	176	8	2,5	0,22	2,9	4,5	2,8
	120	164	86	18	3	115	100	176	8	2,5	0,37	1,7	2,6	1,8

Self-aligning ball bearings on adapter sleeve
d₁ 85 – 110 mm

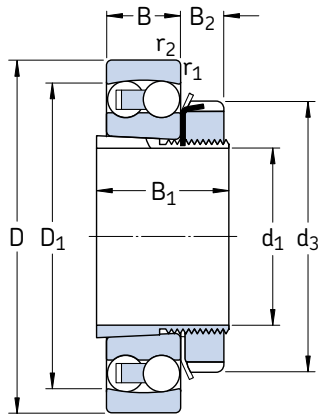

Principal dimensions			Basic load ratings		Fatigue load limit P _u	Speed ratings		Mass Bearing + sleeve	Designations	
d ₁	D	B	dynamic	static		Refer- ence speed	Limiting speed		Bearing	Adapter sleeve
mm			kN		kN	r/min		kg	–	
85	170	32	63,7	27	1,20	8 000	5 000	4,25	1219 K	H 219
	170	43	83,2	34,5	1,53	7 000	5 000	5,30	2219 KM	H 319
	200	45	133	51	2,16	6 300	4 300	7,90	1319 K	H 319
90	180	34	68,9	30	1,29	7 500	4 800	5,00	1220 K	H 220
	180	46	97,5	40,5	1,76	6 700	4 800	6,40	2220 KM	H 320
	215	47	143	57	2,36	6 000	4 000	9,65	1320 K	H 320
	215	73	190	80	3,25	5 600	4 000	14,0	2320 KM	H 2320
100	200	38	88,4	39	1,60	6 700	4 300	6,80	1222 K	H 222
	200	53	124	52	2,12	6 000	4 300	8,85	2222 KM	H 322
	240	50	163	72	2,75	5 300	3 600	13,5	1322 KM	H 322
110	215	42	119	53	2,12	6 300	4 000	8,30	1224 KM	H 3024

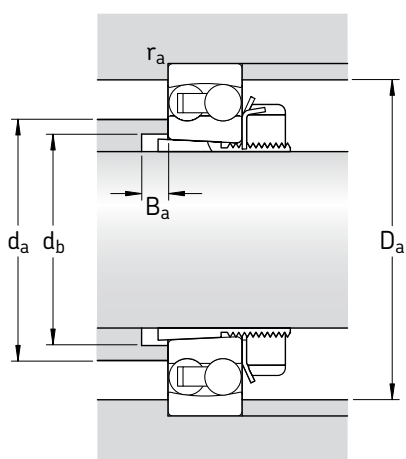

Dimensions						Abutment and fillet dimensions					Calculation factors			
d_1	d_3	D_1 ~	B_1	B_2	$r_{1,2}$ min	d_a max	d_b min	D_a max	B_a min	r_a max	e	Y_1	Y_2	Y_0
mm						mm					-			
85	125	151	55	19	2,1	120	100	158	8	2	0,17	3,7	5,7	4
	125	151	68	19	2,1	118	102	158	10	2	0,27	2,3	3,6	2,5
	125	174	68	19	3	127	102	186	8	2,5	0,23	2,7	4,2	2,8
90	130	159	58	20	2,1	127	106	168	8	2	0,17	3,7	5,7	4
	130	160	71	20	2,1	124	108	168	9	2	0,27	2,3	3,6	2,5
	130	185	71	20	3	136	108	201	8	2,5	0,23	2,7	4,2	2,8
	130	186	97	20	3	130	110	201	8	2,5	0,37	1,7	2,6	1,8
100	145	176	63	21	2,1	140	116	188	8	2	0,17	3,7	5,7	4
	145	177	77	21	2,1	137	118	188	8	2	0,28	2,2	3,5	2,5
	145	206	77	21	3	154	118	226	10	2,5	0,22	2,9	4,5	2,8
110	145	190	72	22	2,1	150	127	203	12	2	0,19	3,3	5,1	3,6



Cylindrical roller bearings



Single row cylindrical roller bearings..... 507

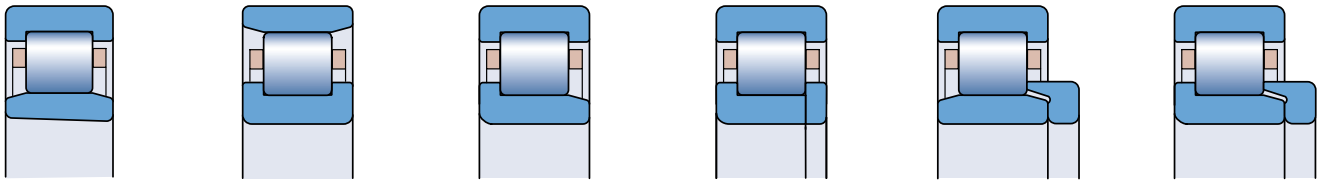

Single row full complement cylindrical roller bearings 559

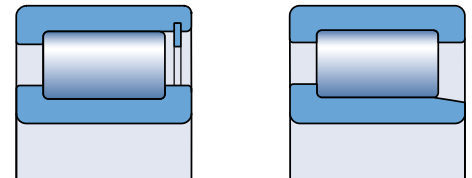

Double row full complement cylindrical roller bearings... 577

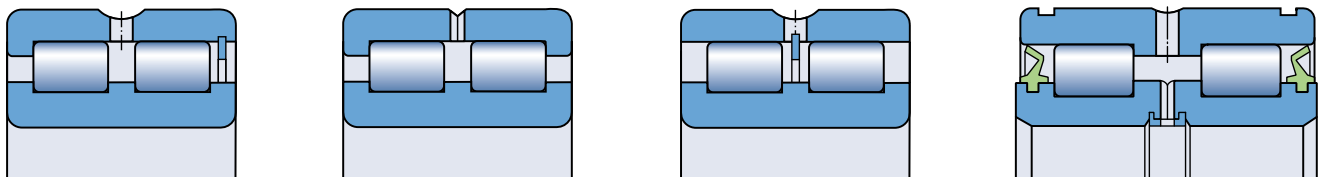

Cylindrical roller bearings

SKF produces cylindrical roller bearings in many designs, dimension series and sizes. The majority are single row bearings with a cage, shown in this catalogue. Single and double row full complement bearings (without cage) complete the SKF standard assortment for general engineering. Bearings with a cage can accommodate heavy radial loads and operate at high speeds. Full complement bearings are suitable for very heavy radial loads at moderate speeds.

The rollers of SKF cylindrical roller bearings are a key component. Their geometry, the so-called logarithmic profile, provides an optimum stress distribution in the contact zones in the bearing. Their surface finish maximizes lubricant film formation and optimizes rolling motion of the rollers. The benefits derived from this compared with traditional designs include enhanced operational reliability and a greater insensitivity to misalignment.

In addition to the standard assortment the comprehensive SKF range of cylindrical roller bearings consists of

- single row high-precision all-steel or hybrid cylindrical roller bearings (→ **fig. 1**)
- double row high-precision all-steel or hybrid cylindrical roller bearings (→ **fig. 2**)
- cylindrical roller bearings and bearing units for railway axleboxes (→ **fig. 3**)
- single row cylindrical roller bearings for traction motors for railway applications
- open and sealed multi-row cylindrical roller bearings for rolling mills (→ **fig. 4**)
- backing bearings for cold rolling mills of the cluster type (→ **fig. 5**)
- indexing roller units for continuous furnaces (→ **fig. 6**).

Details of these bearings can be found in the “SKF Interactive Engineering Catalogue” available on CD-ROM or online at www.skf.com.

Fig. 1

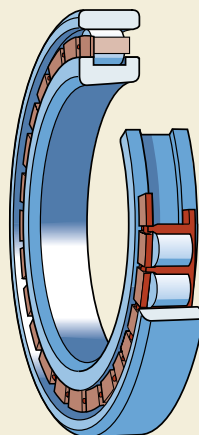

Fig. 2

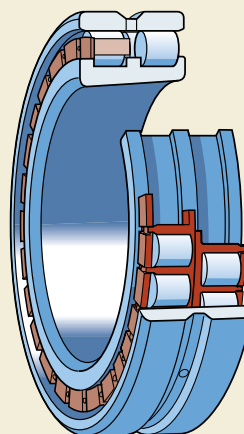

Fig. 3

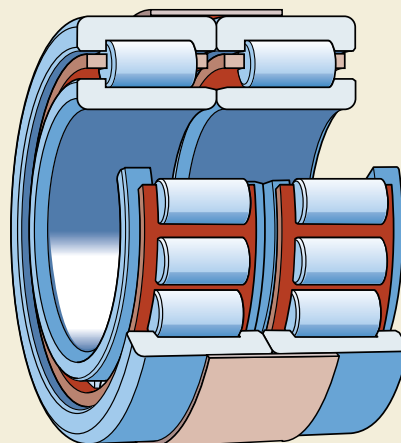
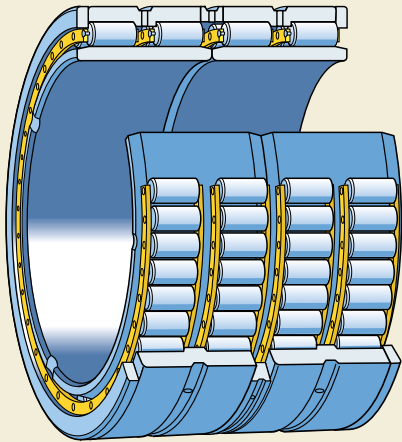

Fig. 4



Other cylindrical roller bearings for special applications include a special electrical insulated coating, called INSOCOAT®. Details of these bearings can be found in this catalogue in the section “Engineering products”, starting on **page 893**.

Fig. 5

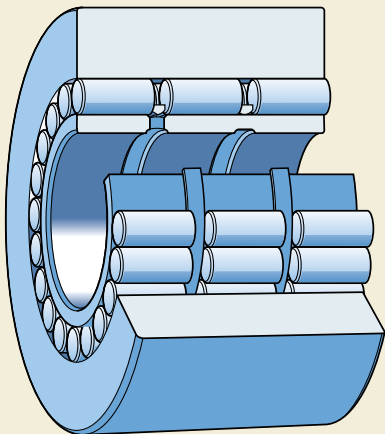
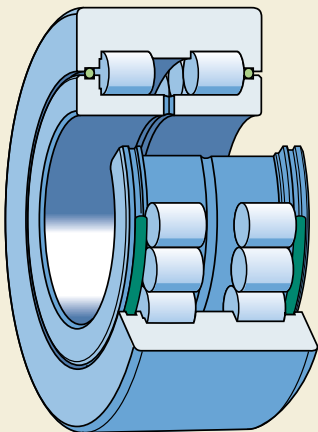

Fig. 6





Single row cylindrical roller bearings

Designs	508
Standard designs.....	508
Angle rings.....	509
Special designs	510
SKF Explorer class bearings	512
Bearing data – general	512
Dimensions.....	512
Tolerances.....	512
Radial internal clearance.....	512
Axial internal clearance	512
Misalignment.....	512
Axial displacement.....	516
Influence of operating temperature on bearing material.....	516
Cages.....	516
Speed ratings.....	517
Minimum load.....	517
Dynamic axial load carrying capacity	518
Equivalent dynamic bearing load	519
Equivalent static bearing load.....	519
Supplementary designations.....	520
Product table	522

Designs

Standard designs

The rollers in a single row cylindrical roller bearing are always guided between the integral “open” flanges on one of the rings (→ **fig. 1**). These “open” flanges combined with the specially designed and surface finished roller ends, provide improved lubrication, reduced friction and consequently lower operating temperature.

The ring with the integral flanges together with the cylindrical roller and cage assembly can be separated from the other ring. This results in easy mounting and dismounting, particularly where the load conditions are such that interference fits are required for both rings.

SKF single row cylindrical roller bearings can accommodate heavy radial loads and high speeds. They are manufactured in several different designs, the main difference being in the configuration of the flanges. The most popular designs (→ **fig. 2**) are described below and listed in the product table starting on **page 522**.

NU design

The outer ring of an NU design bearing has two integral flanges while the inner ring has no flanges (**a**). Axial displacement of the shaft with respect to the housing can be accommodated in both directions.

N design

The inner ring of an N design bearing has two integral flanges while the outer ring has no flanges (**b**). Axial displacement of the shaft with respect to the housing can be accommodated in both directions.

NJ design

The outer ring of an NJ design bearing has two integral flanges and the inner ring has one integral flange (**c**). These bearings can locate the shaft axially in one direction.

NUP design

The outer ring of an NUP design bearing has two integral flanges and the inner ring has one integral flange and one non-integral flange in the form of a loose flange ring (**d**). These bearings can be used as locating bearings to locate the shaft axially in both directions.

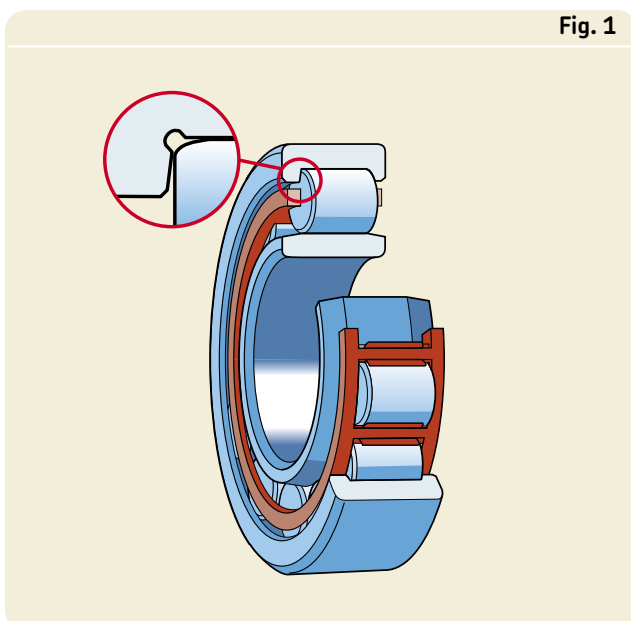
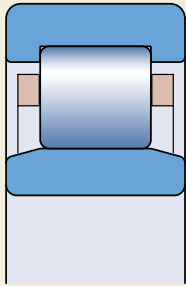
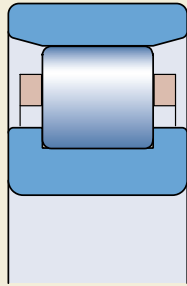

Fig. 1

Fig. 2



a



b

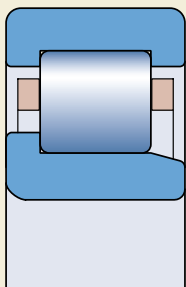

c

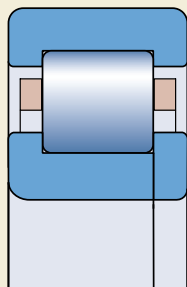

d

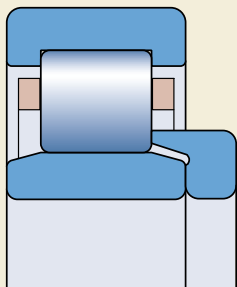

e

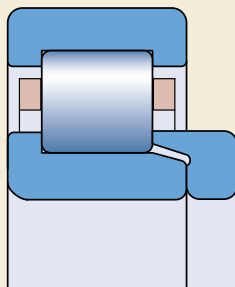

f

Angle rings

Angle rings, series designation HJ, are designed to stabilize NU and NJ design cylindrical roller bearings in the axial direction (**e** and **f**). There can be several reasons to incorporate them in designs:

- NJ or NUP design locating bearings are not available.
- To provide a more stable seating in heavily loaded locating bearing arrangements with NJ design bearings, having a full width inner ring, instead of using an NUP design bearing, that has a shorter inner ring and a loose flange.
- To simplify the design and/or mounting/dis-mounting procedures.

SKF angle rings, manufactured from carbon chromium steel are hardened and ground. The maximum permissible side face runout conforms to the SKF Normal tolerance class for the appropriate bearing. The HJ angle rings, where available, are listed in the product table with their designation and dimensions together with the relevant bearing.

NU design + HJ angle ring

An NU design bearing combined with an HJ angle ring (**e**) can be used to locate the shaft axially in one direction. SKF recommends not to fit standard angle rings on both sides of an NU design bearing as this can lead to axial compression of the rollers.

NJ design + HJ angle ring

An NJ design bearing combined with an HJ angle ring (**f**) can be used to locate the shaft axially in both directions.

Single row cylindrical roller bearings

Special designs

The SKF assortment also includes a selection of NU design cylindrical roller bearings without an inner ring (→ **fig. 3**) – designation prefix RNU – and N design bearings without an outer ring (→ **fig. 4**) – designation prefix RN. These bearings provide a solution for applications where hardened and ground raceways are provided on the shaft or in the housing bore (→ section “Raceways on shafts and in housings” on **page 198**). Because RNU bearings, for example, do not need an inner ring, the shaft diameter can be larger to provide a stronger, stiffer arrangement. Additionally, the possible axial displacement of the shaft relative to the housing is only limited by the width of the raceway on the shaft for the RNU design or in the housing bore for the RN design.

Other single row cylindrical roller bearings included in the SKF assortment are bearings with a wide inner ring and bearings with flange configurations that differ from the standard bearing designs (→ **fig. 5**) and drawing number bearings with non-standard dimensions. Details of these bearings can be found in the “SKF Interactive Engineering Catalogue” available on CD-ROM or online at www.skf.com.

Fig. 3

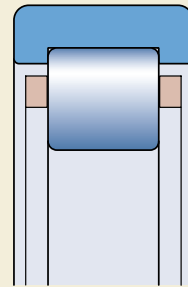

Fig. 4

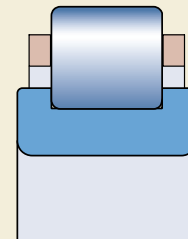
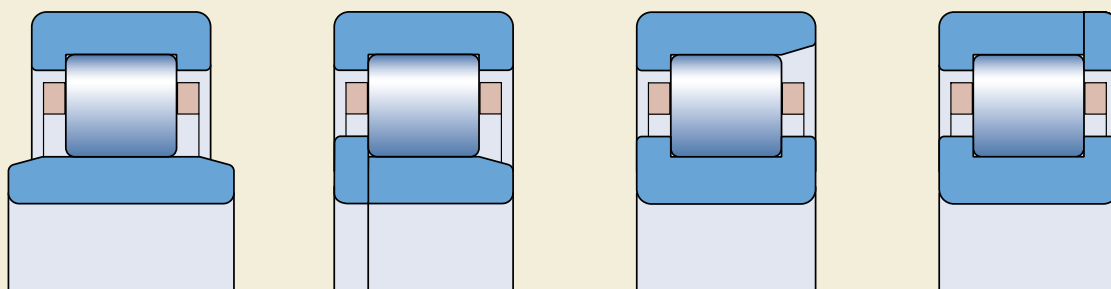

Fig. 5



NUB

NJP

NF

NP

Bearings with a tapered bore

SKF single row cylindrical roller bearings are generally produced with a cylindrical bore. However, some bearings with a tapered bore 1:12 can be supplied (→ **fig. 6**). Bearings with a tapered bore have a somewhat larger radial internal clearance than corresponding bearings with a cylindrical bore and are identified by the designation suffix K. Contact SKF for availability.

Bearings with a snap ring groove

Some single row cylindrical roller bearings are also produced with a snap ring groove in the outer ring (→ **fig. 7**). These bearings are identified by the designation suffix N. Because they can be located axially in the housing bore by a retaining or snap ring, the arrangement design can be simplified and made more compact. Contact SKF for availability before ordering. The dimensions of the snap ring groove and of the chamfer adjacent to the groove are in accordance with ISO 464:1995, which also specifies suitable snap ring dimensions.

Bearings with locating slots

In some applications where it is essential that mounting and dismounting can be done easily, outer rings have to be mounted with clearance fits in the housing. To restrain the outer ring from turning in the circumferential direction, some single row cylindrical roller bearings are also produced with

- one locating slot, designation suffix N1, or
- two locating slots positioned 180° apart, designation suffix N2,

in one outer ring side face (→ **fig. 8**). Please contact SKF for availability before ordering. The dimensions of the locating slots are in accordance with DIN 5412-1:2000.

Fig. 6

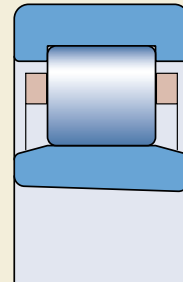

Fig. 7

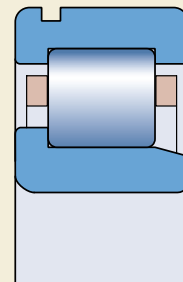
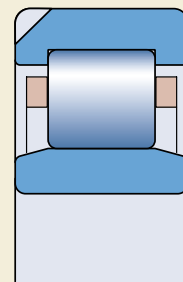

Fig. 8



SKF Explorer class bearings

High performance SKF Explorer cylindrical roller bearings are shown with an asterisk in the product table. SKF Explorer bearings retain the designation of earlier standard bearings, e.g. NU 216 ECP. However, each bearing and its box are marked with the name “EXPLORER”.

Bearing data – general

Dimensions

The dimensions of SKF single row cylindrical roller bearings are in accordance with ISO 15:1998.

The dimensions of the HJ angle rings correspond to those specified in ISO 246: 1995.

Tolerances

SKF single row cylindrical roller bearings are manufactured to Normal tolerances for dimensional accuracy and to P6 tolerances for running accuracy as standard.

The tolerances are in accordance with ISO 492: 2002 and can be found in **tables 3 and 4** on **pages 125 and 126**.

Radial internal clearance

SKF single row cylindrical roller bearings are manufactured with Normal radial internal clearance as standard and most of the bearings are also available with C3 radial internal clearance. Some of the bearings can even be supplied with the smaller C2 or the appreciably greater C4 clearance. In addition, some bearings are produced with special reduced clearances. This special clearance corresponds to a section of a standard clearance range or to sections of two adjacent clearance ranges.

Bearings with non-standard clearance or with the special reduced clearances can be supplied to special order.

The actual clearance limits for bearings with a cylindrical bore are provided in **table 1** and are in accordance with ISO 5753: 1991. They are valid for unmounted bearings under zero measuring load.

The separable components of all SKF bearings with standard clearance as well as those with reduced clearance are interchangeable.

Axial internal clearance

NUP-design cylindrical roller bearings, which can locate a shaft axially in both directions, are manufactured with an axial internal clearance as shown in **table 2**. The axial internal clearance of NJ-design bearings when combined with an HJ angle ring is specified in **table 3**.

The clearance limits quoted in **tables 2 and 3** should be considered as guideline values. When axial internal clearance is measured, the rollers may tilt, causing an enlargement of the axial clearance, which may be as much as

- the radial internal clearance of bearings in the 2, 3 and 4 series or
- 2/3 of the radial internal clearance for bearings in the 22 and 23 series, for example.

Misalignment

The ability of single row cylindrical roller bearings to accommodate angular misalignment of the inner ring with respect to the outer ring is limited to a few minutes of arc. The actual values are

- 4 minutes of arc for bearings in the 10, 12, 2, 3 and 4 series
- 3 minutes of arc for bearings in the 20, 22 and 23 series.

These guideline values apply to non-locating bearings, provided the positions of the shaft and housing axes remain constant. Larger misalignments may be possible but may result in shorter bearing service life. In such cases, it is advisable to contact the SKF application engineering service.

When the bearings are used to locate the shaft axially, guideline values must be reduced, as uneven flange loading can lead to increased wear and possibly even to flange fracture.

The maximum values for misalignment do not apply to bearings of the NUP design or bearings of the NJ design with an HJ angle ring. Because these bearings have two inner and two outer ring flanges and the axial internal clearance is relatively small, axial stresses may be induced in the bearing. In case of doubt, it is advisable to contact the SKF application engineering service.

Table 1

Radial internal clearance of cylindrical roller bearings with a cylindrical bore

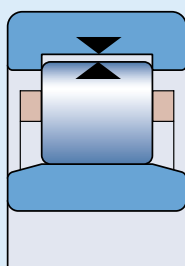

Bore diameter d		Radial internal clearance									
		C2		Normal		C3		C4		C5	
over	incl.	min	max	min	max	min	max	min	max	min	max
mm		μm									
-	24	0	25	20	45	35	60	50	75	65	90
24	30	0	25	20	45	35	60	50	75	70	95
30	40	5	30	25	50	45	70	60	85	80	105
40	50	5	35	30	60	50	80	70	100	95	125
50	65	10	40	40	70	60	90	80	110	110	140
65	80	10	45	40	75	65	100	90	125	130	165
80	100	15	50	50	85	75	110	105	140	155	190
100	120	15	55	50	90	85	125	125	165	180	220
120	140	15	60	60	105	100	145	145	190	200	245
140	160	20	70	70	120	115	165	165	215	225	275
160	180	25	75	75	125	120	170	170	220	250	300
180	200	35	90	90	145	140	195	195	250	275	330
200	225	45	105	105	165	160	220	220	280	305	365
225	250	45	110	110	175	170	235	235	300	330	395
250	280	55	125	125	195	190	260	260	330	370	440
280	315	55	130	130	205	200	275	275	350	410	485
315	355	65	145	145	225	225	305	305	385	455	535
355	400	100	190	190	280	280	370	370	460	510	600
400	450	110	210	210	310	310	410	410	510	565	665
450	500	110	220	220	330	330	440	440	550	625	735
500	560	120	240	240	360	360	480	480	600	690	810
560	630	140	260	260	380	380	500	500	620	780	900
630	710	145	285	285	425	425	565	565	705	865	1 005
710	800	150	310	310	470	470	630	630	790	975	1 135
800	900	180	350	350	520	520	690	690	860	1 095	1 265

Please refer to page 137 for the definition of radial internal clearance

Single row cylindrical roller bearings

Table 2

Axial internal clearance of NUP cylindrical roller bearings

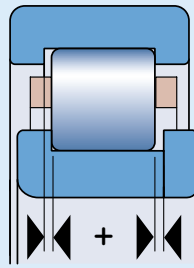

Bearing Bore diameter	Size code	Axial internal clearance of bearings of series							
		NUP 2		NUP 3		NUP 22		NUP 23	
mm	–	min	max	min	max	min	max	min	max
		µm							
15	02	–	–	–	–	–	–	–	–
17	03	37	140	37	140	37	140	47	155
20	04	37	140	37	140	47	155	47	155
25	05	37	140	47	155	47	155	47	155
30	06	37	140	47	155	47	155	47	155
35	07	47	155	47	155	47	155	62	180
40	08	47	155	47	155	47	155	62	180
45	09	47	155	47	155	47	155	62	180
50	10	47	155	47	155	47	155	62	180
55	11	47	155	62	180	47	155	62	180
60	12	47	155	62	180	62	180	87	230
65	13	47	155	62	180	62	180	87	230
70	14	47	155	62	180	62	180	87	230
75	15	47	155	62	180	62	180	87	230
80	16	47	155	62	180	62	180	87	230
85	17	62	180	62	180	62	180	87	230
90	18	62	180	62	180	62	180	87	230
95	19	62	180	62	180	62	180	87	230
100	20	62	180	87	230	87	230	120	315
105	21	62	180	–	–	–	–	–	–
110	22	62	180	87	230	87	230	120	315
120	24	62	180	87	230	87	230	120	315
130	26	62	180	87	230	87	230	120	315
140	28	62	180	87	230	87	230	120	315
150	30	62	180	–	–	87	230	120	315
160	32	87	230	–	–	–	–	–	–
170	34	87	230	–	–	–	–	–	–
180	36	87	230	–	–	–	–	–	–
190	38	87	230	–	–	–	–	–	–
200	40	87	230	–	–	–	–	–	–
220	44	95	230	–	–	–	–	–	–
240	48	95	250	–	–	–	–	–	–
260	52	95	250	–	–	–	–	–	–

Table 3

Axial internal clearance of NJ + HJ cylindrical roller bearings

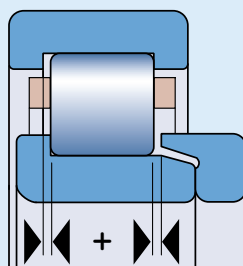

Bearing Bore diameter	Size code	Axial internal clearance of bearings of series									
		NJ 2+HJ 2		NJ 3+HJ 3		NJ 4+HJ 4		NJ 22+HJ 22		NJ 23+HJ 23	
mm	–	µm									
		min	max	min	max	min	max	min	max	min	max
15	02	42	165	42	165	–	–	–	–	–	–
17	03	42	165	42	165	–	–	42	165	52	183
20	04	42	165	42	165	–	–	52	185	52	183
25	05	42	165	52	185	–	–	52	185	52	183
30	06	42	165	52	185	60	200	52	185	52	183
35	07	52	185	52	185	60	200	52	185	72	215
40	08	52	185	52	185	60	200	52	185	72	215
45	09	52	185	52	185	60	200	52	185	72	215
50	10	52	185	52	185	80	235	52	185	72	215
55	11	52	185	72	215	80	235	52	185	72	215
60	12	52	185	72	215	80	235	72	215	102	275
65	13	52	185	72	215	80	235	72	215	102	275
70	14	52	185	72	215	80	235	72	215	102	275
75	15	52	185	72	215	80	235	72	215	102	275
80	16	52	185	72	215	80	235	72	215	102	275
85	17	72	215	72	215	110	290	72	215	102	275
90	18	72	215	72	215	110	290	72	215	102	275
95	19	72	215	72	215	110	290	72	215	102	275
100	20	72	215	102	275	110	290	102	275	140	375
105	21	72	215	102	275	110	290	102	275	140	375
110	22	72	215	102	275	110	290	102	275	140	375
120	24	72	215	102	275	110	310	102	275	140	375
130	26	72	215	102	275	110	310	102	275	140	375
140	28	72	215	102	275	140	385	102	275	140	375
150	30	72	215	102	275	140	385	102	275	140	375
160	32	102	275	102	275	–	–	140	375	140	375
170	34	102	275	–	–	–	–	140	375	–	–
180	36	102	275	–	–	–	–	140	375	–	–
190	38	102	275	–	–	–	–	–	–	–	–
200	40	102	275	–	–	–	–	–	–	–	–
220	44	110	290	–	–	–	–	–	–	–	–
240	48	110	310	–	–	–	–	–	–	–	–
260	52	110	310	–	–	–	–	–	–	–	–
280	56	110	310	–	–	–	–	–	–	–	–

Single row cylindrical roller bearings

Axial displacement

Cylindrical roller bearings with a flangeless inner or outer ring, NU and N designs, and NJ-design bearings with one integral flange at the inner ring can accommodate axial displacement of the shaft with respect to the housing as a result of thermal expansion within certain limits (→ **fig. 9**). As the axial displacement takes place within the bearing and not between the bearing and shaft or housing bore, there is practically no increase in friction as the bearing rotates. Values for the permissible axial displacement “s” from the normal position of one bearing ring relative to the other are provided in the product table.

Influence of operating temperature on bearing material

SKF cylindrical roller bearings undergo a special heat treatment. When equipped with a steel, brass or PEEK cage, they can operate at temperatures of up to +150 °C.

Cages

Depending on the bearing series, size and design, SKF single row cylindrical roller bearings are fitted as standard with one of the following cages (→ **fig. 10**)

- an injection moulded window-type cage of glass fibre reinforced polyamide 6,6, roller centred, designation suffix P (**a**)
- a pressed window-type cage of unhardened steel, roller centred, designation suffix J (**b**)
- a one-piece machined window-type brass cage, inner or outer ring centred, designation suffixes ML or MP (**c**)
- a two-piece machined brass cage, roller centred, designation suffix M, or outer ring centred, designation suffix MA, or inner ring centred, designation suffix MB (**d**).

A large number of bearings included in the SKF standard assortment are available as standard with more than one cage design so that bearings with cages appropriate to the operating conditions can be chosen (→ product table).

For demanding applications, like compressors, the use of SKF bearings with an injection moulded cage of glass fibre reinforced polyetheretherketone (PEEK) has become more common. The exceptional properties of PEEK are superior

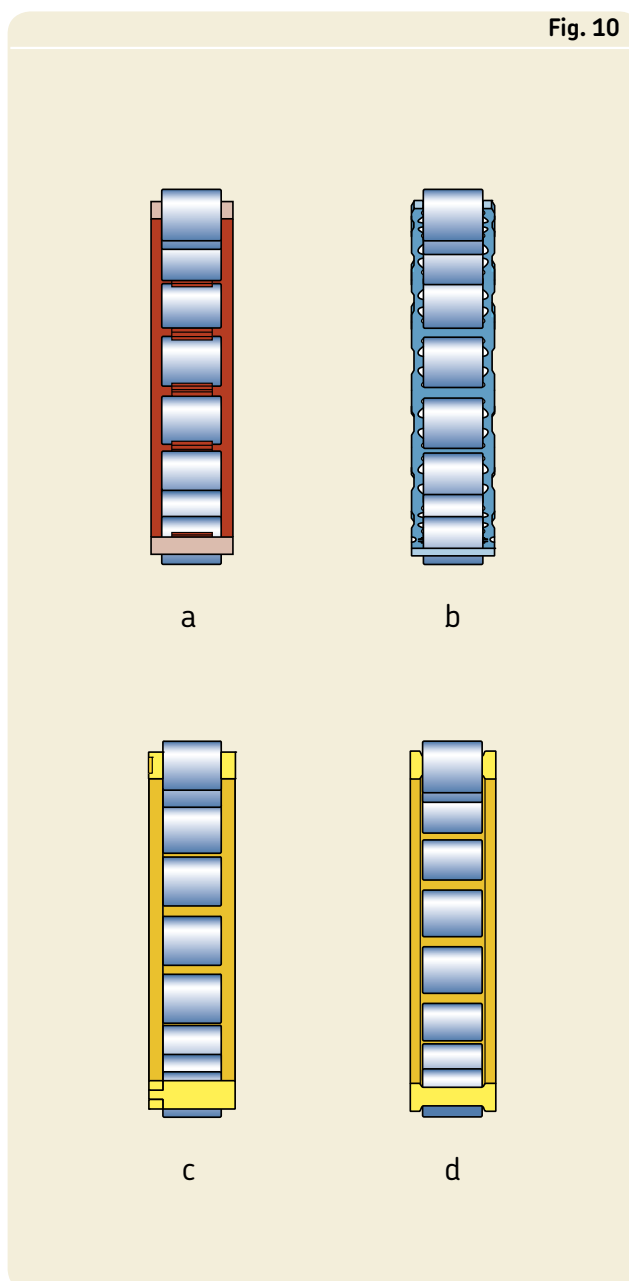
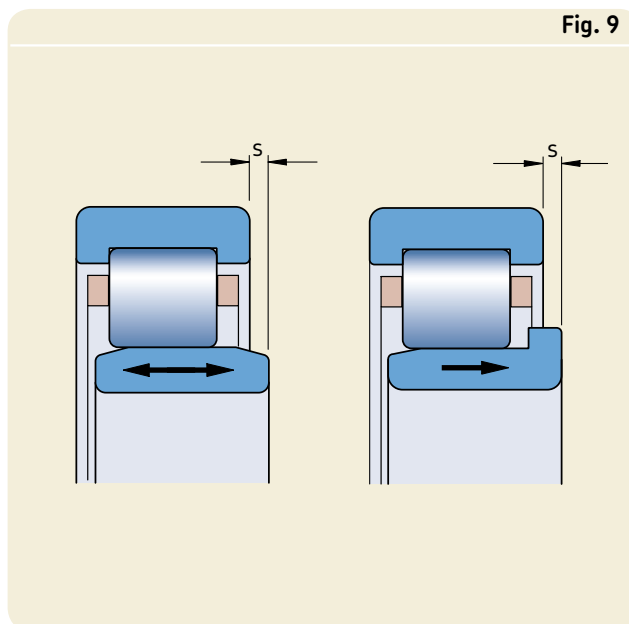

combination of strength and flexibility, high operating temperature range, high chemical and wear resistance and good processability. If bearings with a PEEK cage are required, please consult the SKF application engineering service.

Note

Single row cylindrical roller bearings with a polyamide cage can be operated at operating temperatures up to +120 °C. The lubricants generally used for rolling bearings do not have a detrimental effect on cage properties, with the exception for a few synthetic oils and greases with synthetic base oil as well as some lubricants containing a high proportion of EP additives when used at elevated temperatures.

For bearing arrangements, which are to operate at continuously high temperatures or under difficult conditions, the use of bearings with a metallic cage is recommended. For applications in equipment using refrigerants such as ammonia or freon replacements, bearings with a polyamide cage can be used for operating temperatures up to 70 °C. At higher operating temperatures bearings incorporating a brass, steel or PEEK cage should be used.

For detailed information about the temperature resistance and the applicability of cages, please refer to the section “Cage materials”, starting on **page 140**.

Speed ratings

The limiting speeds are determined by certain criteria that include the form stability and the strength of the cage (→ section “Limiting speeds” on **page 114**). The values listed in the product table are valid for the standard cage. To facilitate the estimation of the limiting speed for bearings with an alternative cage or vice-versa, **table 4** provides the appropriate conversion factors.

Table 4

Conversion factors for limiting speeds			
Bearing with standard cage	alternative standard cage		
	P, J, M, MR	MA, MB	ML, MP
P, J, M, MR	1	1,3	1,5
MA, MB	0,75	1	1,2
ML, MP	0,65	0,85	1

Minimum load

In order to provide satisfactory operation, single row cylindrical roller bearings, like all ball and roller bearings, must always be subjected to a given minimum load, particularly if they are to operate at high speeds or are subjected to high accelerations or rapid changes in the direction of load. Under such conditions, the inertia forces of the rollers and cage, and the friction in the lubricant, can have a detrimental influence on the rolling conditions in the bearing arrangement and may cause damaging sliding movements to occur between the rollers and raceways.

The requisite minimum load to be applied to single row cylindrical roller bearings can be estimated using

$$F_{rm} = k_r \left(6 + \frac{4n}{n_r} \right) \left(\frac{d_m}{100} \right)^2$$

where

F_{rm} = minimum radial load, kN

k_r = minimum load factor
(→ product table)

n = rotational speed, r/min

n_r = reference speed, r/min
(→ product table)

d_m = bearing mean diameter
= 0,5 (d + D), mm

When starting up at low temperatures or when the lubricant is highly viscous, even greater minimum loads may be required. The weight of the components supported by the bearing, together with external forces, generally exceeds the requisite minimum load. If this is not the case, the single row cylindrical roller bearing must be subjected to an additional radial load.

Single row cylindrical roller bearings

Dynamic axial load carrying capacity

Single row cylindrical roller bearings with flanges on both inner and outer rings can support axial loads in addition to radial loads. Their axial load carrying capacity is primarily determined by the ability of the sliding surfaces of the roller end/flange contact to support loads. Factors having the greatest effect on this ability are the lubrication, operating temperature and heat dissipation from the bearing.

Assuming the conditions cited below, the permissible axial load can be calculated with sufficient accuracy from

$$F_{ap} = \frac{k_1 C_0 10^4}{n (d + D)} - k_2 F_r$$

where

F_{ap} = permissible axial load, kN

C_0 = basic static load rating, kN

F_r = actual radial bearing load, kN

n = rotational speed, r/min

d = bearing bore diameter, mm

D = bearing outside diameter, mm

k_1 = a factor

1,5 for oil lubrication

1 for grease lubrication

k_2 = a factor

0,15 for oil lubrication

0,1 for grease lubrication

The above equation is based on conditions that are considered typical for normal bearing operation, i.e.

- a difference of 60 °C between the bearing operating temperature and the ambient temperature
- a specific heat loss from the bearing of 0,5 mW/mm² °C; with reference to the bearing outside diameter surface ($\pi D B$)
- a viscosity ratio $\kappa = 2$.

For grease lubrication the viscosity of the base oil in the grease may be used. If κ is less than 2, the friction will increase and there will be more wear. These effects can be reduced at low speeds, for example, by using oils with AW (anti-wear) and/or EP (extreme pressure) additives.

Where axial loads act for longer periods and the bearings are grease lubricated, it is advisable to use grease that has good oil bleeding

properties at the operating temperatures (> 3 % according to DIN 51 817). Frequent relubrication is also recommended.

The values of the permissible load F_{ap} obtained from the heat balance equation are valid for a continuously acting constant axial load and adequate lubricant supply to the roller end/flange contacts. Where axial loads act only for short periods, the values may be multiplied by a factor of 2, or for shock loads by a factor of 3, provided the limits given in the following with regard to flange strength are not exceeded.

To avoid any risk of flange breakage, the constantly acting axial load applied to the bearings should never exceed

$$F_{a \max} = 0,0045 D^{1,5} \text{ (bearings in the 2 Diameter Series)}$$

or

$$F_{a \max} = 0,0023 D^{1,7} \text{ (bearings in other series)}$$

When acting only occasionally and for brief periods, the axial load applied to the bearings should never exceed

$$F_{a \max} = 0,013 D^{1,5} \text{ (bearings in the 2 Diameter Series)}$$

or

$$F_{a \max} = 0,007 D^{1,7} \text{ (bearings in other series)}$$

where

$F_{a \max}$ = maximum constantly or occasionally acting axial load, kN

D = bearing outside diameter, mm

To obtain an even flange load and provide sufficient running accuracy of the shaft when single row cylindrical roller bearings are subjected to heavy axial loads, axial runout and the size of the abutment surfaces of adjacent components become particularly important. For the axial runout see the recommendations provided in the section "Dimensional, form and running accuracy of bearing seatings and abutments" on **page 194**. As to the diameter of the abutment surfaces, SKF recommends supporting the inner ring at a height corresponding to half of the flange height (→ **fig. 11**). For the inner ring

flange, for example, the abutment diameter can be obtained using

$$d_{as} = 0,5 (d_1 + F)$$

where

d_{as} = shaft abutment diameter, mm

d_1 = inner ring flange diameter, mm

F = inner ring raceway diameter, mm

Where the misalignment between the inner and outer rings exceeds 1 minute of arc, the action of the load on the flange changes considerably. The safety factors included in the guideline values may be inadequate. In these cases, please contact the SKF application engineering service.

Equivalent dynamic bearing load

For non-locating bearing

$$P = F_r$$

If bearings with flanges on both inner and outer rings are used to locate a shaft in one or both directions, the equivalent dynamic bearing load should be calculated using

$$P = F_r \quad \text{when } F_a/F_r \leq e$$

$$P = 0,92 F_r + Y F_a \quad \text{when } F_a/F_r > e$$

where

e = limiting value

= 0,2 for bearings in the 10, 2, 3 and 4 series

= 0,3 for bearings in other series

Y = axial load factor

= 0,6 for bearings in the 10, 2, 3 and 4 series

= 0,4 for bearings in other series

Since axially loaded cylindrical roller bearings only operate satisfactorily when they are subjected to a simultaneously acting radial load, the ratio F_a/F_r should not exceed 0,5.

Equivalent static bearing load

$$P_0 = F_r$$

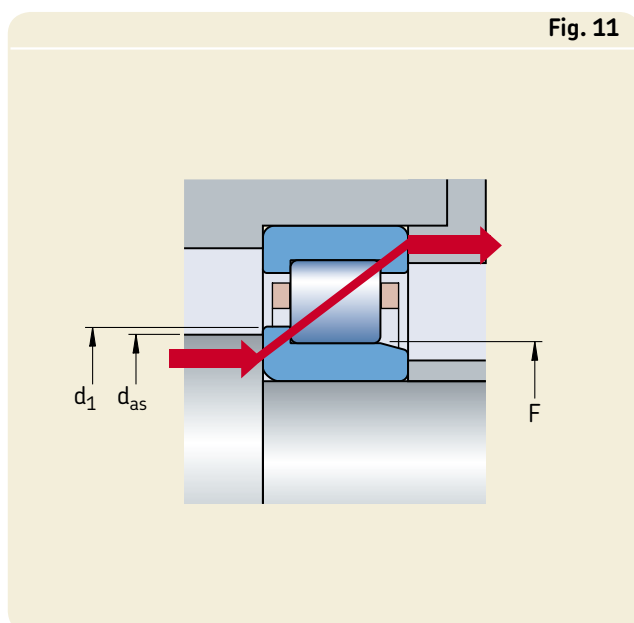

Single row cylindrical roller bearings

Supplementary designations

The designation suffixes used to identify certain features of SKF single row cylindrical roller bearings are explained in the following.

CN	Normal radial internal clearance; normally only used together with an additional letter that identifies a reduced or displaced clearance range	N1	One locating slot (notch) in one outer ring side face
H	Reduced clearance range corresponding to the upper half of the actual clearance range	N2	Two locating slots 180° apart in one outer ring side face
L	Reduced clearance range corresponding to the lower half of the actual clearance range	P	Injection moulded cage of glass fibre reinforced polyamide 6,6, roller centred
The above letters are also used together with the clearance class suffixes C2, C3, C4 and C5		PH	Injection moulded cage of polyetheretherketone (PEEK), roller centred
C2	Radial internal clearance smaller than Normal	PHA	Injection moulded cage of polyetheretherketone (PEEK), outer ring centred
C3	Radial internal clearance greater than Normal	S1	Rings dimensionally stabilized for operating temperatures up to +200 °C
C4	Radial internal clearance greater than C3	S2	Rings dimensionally stabilized for operating temperatures up to +250 °C
C5	Radial internal clearance greater than C4	VA301	Bearing for railway vehicle traction motors
EC	Optimized internal design incorporating more and/or larger rollers and with modified roller end/flange contact	VA305	VA301 + special inspection routines
HA3	Case-hardened inner ring	VA350	Bearing for railway axleboxes
HB1	Bainite hardened inner and outer rings	VA380	Bearing for railway axleboxes according to EN 12080:1998, class 1
HN1	Inner and outer rings with special surface heat treatment	VA3091	VA301 + VL0241
J	Pressed steel cage, roller centred, unhardened	VC025	Bearing with specially wear-resistant raceways for applications in heavily contaminated environments
K	Tapered bore, taper 1:12	VL0241	Aluminium-oxide coated outside surface of the outer ring for electrical resistance up to 1 000 V DC
M	Two-piece machined brass cage, roller centred	VL2071	Aluminium-oxide coated outside surface of the inner ring for electrical resistance up to 1 000 V DC
MA	Two-piece machined brass cage, outer ring centred	VQ015	Inner ring with crowned raceway for increased permissible misalignment
MB	Two-piece machined brass cage, inner ring centred		
ML	One-piece form-turned window-type brass cage, inner or outer ring centred		
MP	One-piece window-type brass cage with milled, reamed or broached pockets, inner or outer ring centred		
MR	One-piece form-turned window-type brass cage, roller centred		
N	Snap ring groove in the outer ring		
NR	Snap ring groove in the outer ring, with appropriate snap ring		

Single row cylindrical roller bearings

d 15–25 mm

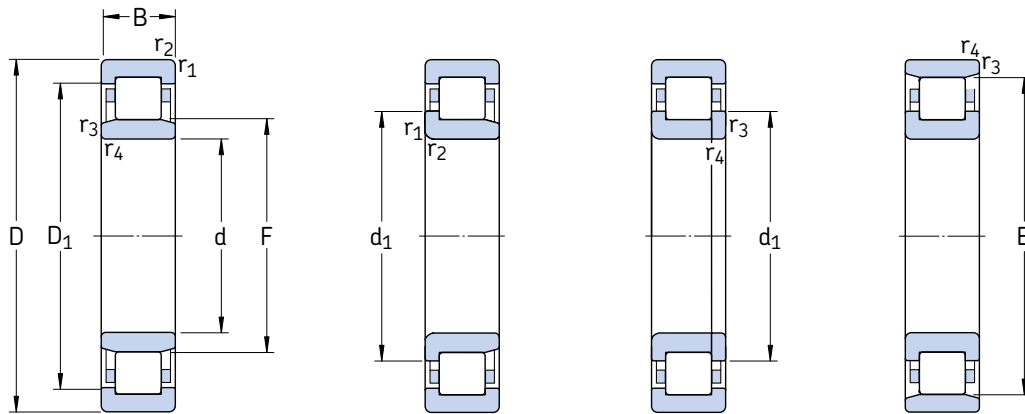

NU

NJ

NUP

N

Principal dimensions			Basic load ratings dynamic static		Fatigue load limit P_u	Speed ratings Refer- ence speed Limiting speed		Mass Bearing with standard cage	Designations Bearing with standard cage	Alternative standard cage designs ¹⁾	
d	D	B	C	C_0				kg	–		
mm			kN		kN	r/min		kg	–		
15	35	11	12,5	10,2	1,22	22 000	26 000	0,047	NU 202 ECP	–	
	35	11	12,5	10,2	1,22	22 000	26 000	0,048	NJ 202 ECP	–	
17	40	12	17,2	14,3	1,73	19 000	22 000	0,068	NU 203 ECP	ML	
	40	12	17,2	14,3	1,73	19 000	22 000	0,070	NJ 203 ECP	ML	
	40	12	17,2	14,3	1,73	19 000	22 000	0,073	NUP 203 ECP	ML	
	40	12	17,2	14,3	1,73	19 000	22 000	0,066	N 203 ECP	–	
	40	16	23,8	21,6	2,65	19 000	22 000	0,087	NU 2203 ECP	–	
	40	16	23,8	21,6	2,65	19 000	22 000	0,093	NJ 2203 ECP	–	
	40	16	23,8	21,6	2,65	19 000	22 000	0,097	NUP 2203 ECP	–	
	47	14	24,6	20,4	2,55	15 000	20 000	0,12	NU 303 ECP	–	
	47	14	24,6	20,4	2,55	15 000	20 000	0,12	NJ 303 ECP	–	
	47	14	24,6	20,4	2,55	15 000	20 000	0,12	N 303 ECP	–	
	20	47	14	25,1	22	2,75	16 000	19 000	0,11	NU 204 ECP	ML
		47	14	25,1	22	2,75	16 000	19 000	0,11	NJ 204 ECP	ML
47		14	25,1	22	2,75	16 000	19 000	0,12	NUP 204 ECP	ML	
47		14	25,1	22	2,75	16 000	19 000	0,11	N 204 ECP	–	
47		18	29,7	27,5	3,45	16 000	19 000	0,14	NU 2204 ECP	–	
47		18	29,7	27,5	3,45	16 000	19 000	0,14	NJ 2204 ECP	–	
52		15	35,5	26	3,25	15 000	18 000	0,15	* NU 304 ECP	–	
52		15	35,5	26	3,25	15 000	18 000	0,15	* NJ 304 ECP	–	
52		15	35,5	26	3,25	15 000	18 000	0,16	* NUP 304 ECP	–	
52		15	35,5	26	3,25	15 000	18 000	0,15	* N 304 ECP	–	
52		21	47,5	38	4,8	14 000	18 000	0,21	* NU 2304 ECP	–	
52		21	47,5	38	4,8	14 000	18 000	0,22	* NJ 2304 ECP	–	
52		21	47,5	38	4,8	14 000	18 000	0,23	* NUP 2304 ECP	–	
25		47	12	14,2	13,2	1,4	18 000	18 000	0,083	NU 1005	–
		52	15	28,6	27	3,35	14 000	16 000	0,13	NU 205 ECP	J, ML
		52	15	28,6	27	3,35	14 000	16 000	0,14	NJ 205 ECP	J, ML
		52	15	28,6	27	3,35	14 000	16 000	0,14	NUP 205 ECP	ML
		52	15	28,6	27	3,35	14 000	16 000	0,13	N 205 ECP	–

* SKF Explorer bearing

¹⁾ When ordering bearings with an alternative standard cage the suffix of the standard cage has to be replaced by the suffix of the cage in question, e.g. NU 203 ECP becomes NU 203 ECML (for speed ratings → page 517)

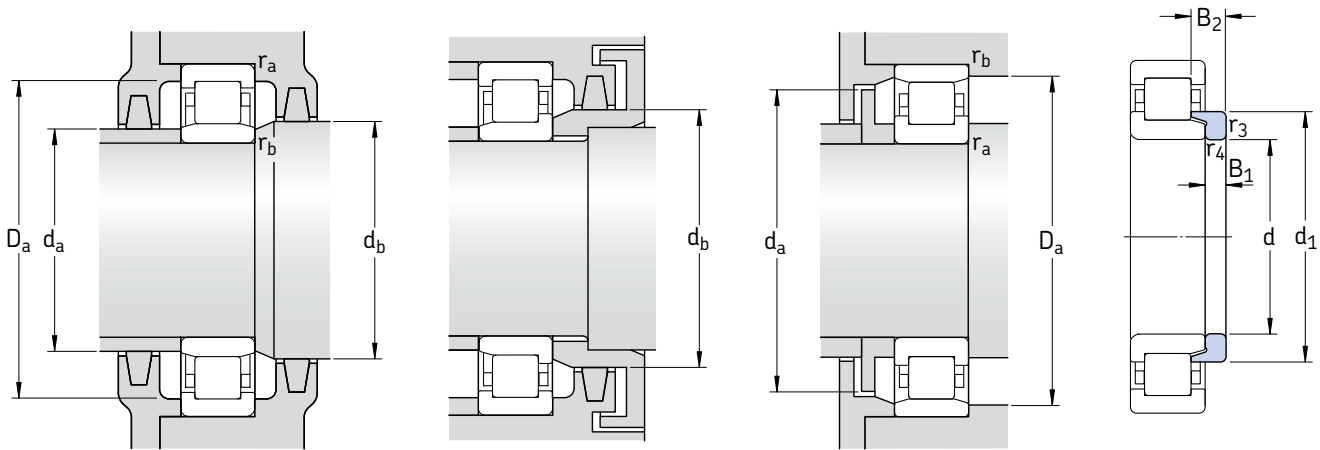

Angle ring

Dimensions							Abutment and fillet dimensions						Calculation factor	Angle ring	Mass	Dimensions	
d	d ₁	D ₁	F, E	r _{1,2}	r _{3,4}	s ¹⁾	d _a	d _a	d _b , D _a	D _a	r _a	r _b	k _r	Designation	kg	B ₁	B ₂
							mm						-	-		mm	
15	-	27,9	19,3	0,6	0,3	1	17,4	18,5	21	30,8	0,6	0,3	0,15	-			
	21,9	27,9	19,3	0,6	0,3	1	18,5	18,5	23	30,8	0,6	0,3	0,15	-			
17	-	32,4	22,1	0,6	0,3	1	19,4	21	24	35,8	0,6	0,3	0,15	-			
	25	32,4	22,1	0,6	0,3	1	21	21	27	35,8	0,6	0,3	0,15	-			
	25	32,4	22,1	0,6	0,3	-	21,2	-	27	35,8	0,6	0,3	0,15	-			
	25	-	35,1	0,6	0,3	1	21,2	33	37	37,6	0,6	0,3	0,15	-			
	-	32,4	22,1	0,6	0,3	1,5	19,4	21	24	35,8	0,6	0,3	0,20	-			
	25	32,4	22,1	0,6	0,3	1,5	21	21	27	35,8	0,6	0,3	0,20	-			
	25	32,4	22,1	0,6	0,3	-	21,2	-	27	35,8	0,6	0,3	0,20	-			
	-	37	24,2	1	0,6	1	21,2	23	26	41,4	1	0,6	0,15	-			
	27,7	37	24,2	1	0,6	1	22,6	23	29	41,4	1	0,6	0,15	-			
	27,7	-	40,2	1	0,6	1	22,6	38	42	42,8	1	0,6	0,15	-			
20	-	38,8	26,5	1	0,6	1	24,2	25	28	41,4	1	0,6	0,15	-			
	29,7	38,8	26,5	1	0,6	1	25	25	31	41,4	1	0,6	0,15	-			
	29,7	38,8	26,5	1	0,6	-	25,6	-	31	41,4	1	0,6	0,15	-			
	29,7	-	41,5	1	0,6	1	25,6	40	43	42,8	1	0,6	0,15	-			
	-	38,8	26,5	1	0,6	2	24,2	25	28	41,4	1	0,6	0,20	-			
	29,7	38,8	26,5	1	0,6	2	25	25	31	41,4	1	0,6	0,20	-			
	31,2	42,4	27,5	1,1	0,6	0,9	24,2	26	29	45	1	0,6	0,15	HJ 304 EC	0,017	4	6,5
	31,2	42,4	27,5	1,1	0,6	0,9	27	29	33	45	1	0,6	0,15	HJ 304 EC	0,017	4	6,5
	31,2	42,4	27,5	1,1	0,6	-	27	-	33	45	1	0,6	0,15	-			
	31,2	-	45,5	1,1	0,6	0,9	27	44	47	47,8	1	0,6	0,15	-			
	-	42,4	27,5	1,1	0,6	1,9	24,2	26	29	45	1	0,6	0,29	-			
	31,2	42,4	27,5	1,1	0,6	1,9	26	26	33	45	1	0,6	0,29	-			
	31,2	42,4	27,5	1,1	0,6	-	27	-	33	45	1	0,6	0,29	-			
	25	-	38,8	30,5	0,6	0,3	2	27	29	32	43,8	0,6	0,3	0,1	-		
34,7		43,8	31,5	1	0,6	1,3	29,2	30	33	46,4	1	0,6	0,15	HJ 205 EC	0,014	3	6
34,7		43,8	31,5	1	0,6	1,3	30	30	36	46,4	1	0,6	0,15	HJ 205 EC	0,014	3	6
34,7		43,8	31,5	1	0,6	-	30,6	-	36	46,4	1	0,6	0,15	-			
34,7		-	46,5	1	0,6	1,3	30,6	45	48	47,8	1	0,6	0,15	-			

¹⁾ Permissible axial displacement from the normal position of one bearing ring in relation to the other

Single row cylindrical roller bearings

d 25 – 30 mm

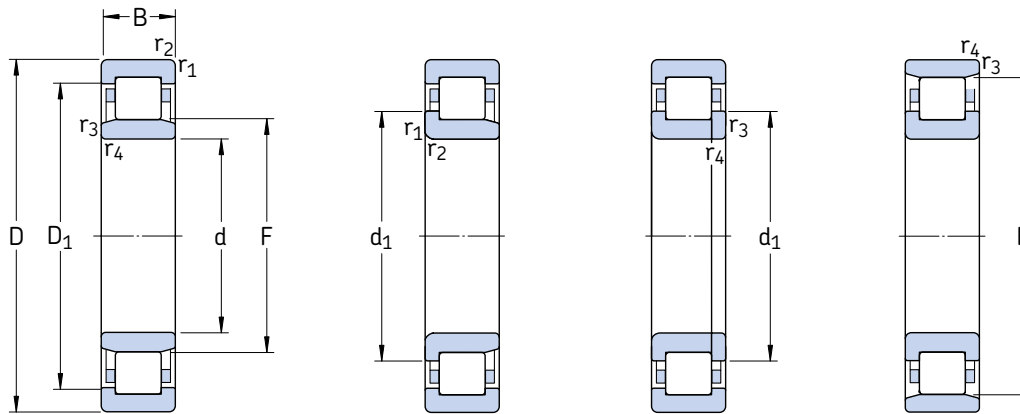

NU

NJ

NUP

N

Principal dimensions			Basic load ratings dynamic static		Fatigue load limit P_u	Speed ratings Refer- ence speed Limiting speed		Mass Bearing with standard cage	Designations Bearing with standard cage	Alternative standard cage designs ¹⁾	
d	D	B	C	C_0							
mm			kN		kN	r/min		kg	–		
25 cont.	52	18	34,1	34	4,25	14 000	16 000	0,16	NU 2205 ECP	ML	
	52	18	34,1	34	4,25	14 000	16 000	0,17	NJ 2205 ECP	ML	
	52	18	34,1	34	4,25	14 000	16 000	0,17	NUP 2205 ECP	ML	
	62	17	46,5	36,5	4,55	12 000	15 000	0,24	* NU 305 ECP	J, ML	
	62	17	46,5	36,5	4,55	12 000	15 000	0,24	* NJ 305 ECP	J, ML	
	62	17	46,5	36,5	4,55	12 000	15 000	0,25	* NUP 305 ECP	J, ML	
	62	17	46,5	36,5	4,55	12 000	15 000	0,24	* N 305 ECP	–	
	62	24	64	55	6,95	12 000	15 000	0,34	* NU 2305 ECP	J, ML	
	62	24	64	55	6,95	12 000	15 000	0,35	* NJ 2305 ECP	ML	
	62	24	64	55	6,95	12 000	15 000	0,36	* NUP 2305 ECP	ML	
	30	55	13	17,9	17,3	1,86	14 000	15 000	0,12	NU 1006	–
		62	16	44	36,5	4,55	13 000	14 000	0,20	* NU 206 ECP	J, ML
62		16	44	36,5	4,55	13 000	14 000	0,20	* NJ 206 ECP	J, ML	
62		16	44	36,5	4,55	13 000	14 000	0,21	* NUP 206 ECP	ML	
62		16	44	36,5	4,55	13 000	14 000	0,20	* N 206 ECP	–	
62		20	55	49	6,1	13 000	14 000	0,26	* NU 2206 ECP	J, ML	
62		20	55	49	6,1	13 000	14 000	0,26	* NJ 2206 ECP	J, ML	
62		20	55	49	6,1	13 000	14 000	0,27	* NUP 2206 ECP	ML	
72		19	58,5	48	6,2	11 000	12 000	0,36	* NU 306 ECP	J, M, ML	
72		19	58,5	48	6,2	11 000	12 000	0,36	* NJ 306 ECP	J, M, ML	
72		19	58,5	48	6,2	11 000	12 000	0,38	* NUP 306 ECP	J, M, ML	
72		19	58,5	48	6,2	11 000	12 000	0,36	* N 306 ECP	–	
72		27	83	75	9,65	11 000	12 000	0,53	* NU 2306 ECP	ML	
72		27	83	75	9,65	11 000	12 000	0,54	* NJ 2306 ECP	ML	
72		27	83	75	9,65	11 000	12 000	0,55	* NUP 2306 ECP	ML	
90		23	60,5	53	6,8	9 000	11 000	0,75	NU 406	–	
90		23	60,5	53	6,8	9 000	11 000	0,79	NJ 406	–	

* SKF Explorer bearing

¹⁾ When ordering bearings with an alternative standard cage the suffix of the standard cage has to be replaced by the suffix of the cage in question, e.g. NU 2205 ECP becomes NU 2205 ECML (for speed ratings → page 517)

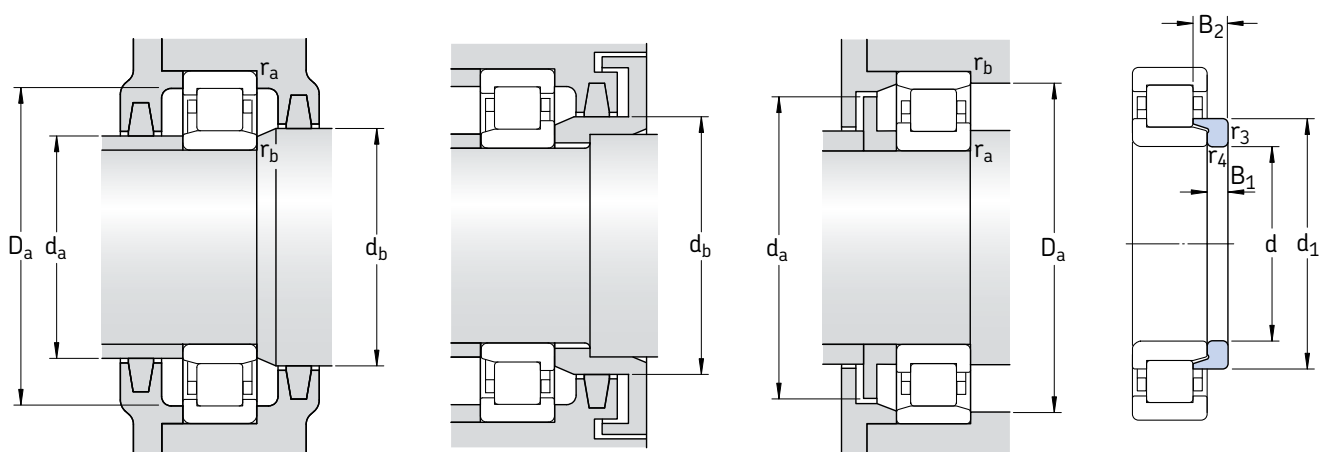

Angle ring

Dimensions							Abutment and fillet dimensions						Calculation factor	Angle ring	Mass	Dimensions	
d	d ₁	D ₁	F, E	r _{1,2}	r _{3,4}	s ¹⁾	d _a	d _a	d _b , D _a	D _a	r _a	r _b	k _r	Designation	kg	B ₁	B ₂
mm	~	~		min	min		min	max	min	max	max	max	–	–		mm	mm
25 cont.	34,7	43,8	31,5	1	0,6	1,8	29,2	30	33	46,4	1	0,6	0,20	HJ 2205 EC	0,014	3	6,5
	34,7	43,8	31,5	1	0,6	1,8	30	30	36	46,4	1	0,6	0,20	HJ 2205 EC	0,014	3	6,5
	34,7	43,8	31,5	1	0,6	–	30,6	–	36	46,4	1	0,6	0,20	–			
	38,1	50,7	34	1,1	1,1	1,3	32	32	36	55	1	1	0,15	HJ 305 EC	0,023	4	7
	38,1	50,7	34	1,1	1,1	1,3	32	32	40	55	1	1	0,15	HJ 305 EC	0,023	4	7
	38,1	50,7	34	1,1	1,1	–	32	–	40	55	1	1	0,15	–			
	38,1	–	54	1,1	1,1	1,3	32	52	56	55	1	1	0,15	–			
	38,1	50,7	34	1,1	1,1	2,3	32	32	36	55	1	1	0,25	HJ 2305 EC	0,025	4	8
	38,1	50,7	34	1,1	1,1	2,3	32	32	40	55	1	1	0,25	HJ 2305 EC	0,025	4	8
	38,1	50,7	34	1,1	1,1	–	32	–	40	55	1	1	0,25	–			
30	–	45,6	36,5	1	0,6	2,1	33,2	35	38	50,4	1	0,6	0,1	–			
	41,2	52,5	37,5	1	0,6	1,3	34,2	36	39	56,4	1	0,6	0,15	HJ 206 EC	0,025	4	7
	41,2	52,5	37,5	1	0,6	1,3	35,6	36	43	56,4	1	0,6	0,15	HJ 206 EC	0,025	4	7
	41,2	52,5	37,5	1	0,6	–	35,6	–	43	56,4	1	0,6	0,15	–			
	41,2	–	55,5	1	0,6	1,3	35,6	54	57	57,8	1	0,6	0,15	–			
	–	52,5	37,5	1	0,6	1,8	34	36	39	57	1	0,6	0,2	–			
	41,2	52,5	37,5	1	0,6	1,8	34	36	43	57	1	0,6	0,2	–			
	41,2	52,5	37,5	1	0,6	–	34	–	43	57	1	0,6	0,2	–			
	45	58,9	40,5	1,1	1,1	1,4	37	39	42	65	1	1	0,15	HJ 306 EC	0,042	5	8,5
	45	58,9	40,5	1,1	1,1	1,4	37	39	47	65	1	1	0,15	HJ 306 EC	0,042	5	8,5
	45	58,9	40,5	1,1	1,1	–	37	–	47	65	1	1	0,15	–			
	45	–	62,5	1,1	1,1	1,4	37	60	64	65	1	1	0,15	–			
	–	58,9	40,5	1,1	1,1	2,4	37	39	42	65	1	1	0,25	–			
	45	58,9	40,5	1,1	1,1	2,4	37	39	47	65	1	1	0,25	–			
	45	58,9	40,5	1,1	1,1	–	37	–	47	65	1	1	0,25	–			
	50,5	66,6	45	1,5	1,5	1,6	41	43	47	79	1,5	1,5	0,15	HJ 406	0,080	7	11,5
	50,5	66,6	45	1,5	1,5	1,6	41	43	47	79	1,5	1,5	0,15	HJ 406	0,080	7	11,5

¹⁾ Permissible axial displacement from the normal position of one bearing ring in relation to the other

Single row cylindrical roller bearings

d 35 – 40 mm

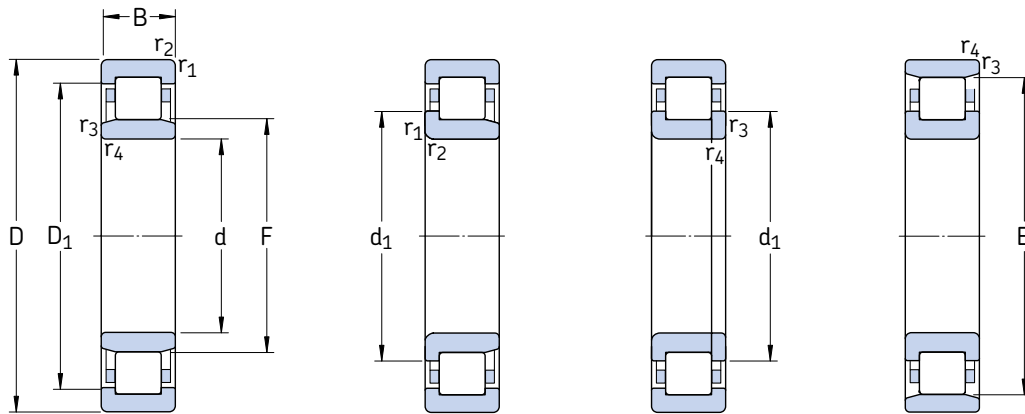

NU

NJ

NUP

N

Principal dimensions			Basic load ratings dynamic static		Fatigue load limit P_u	Speed ratings Reference speed Limiting speed		Mass Bearing with standard cage	Designations Bearing with standard cage	Alternative standard cage designs ¹⁾
d	D	B	C	C_0						
mm			kN		kN	r/min		kg	–	
35	62	14	35,8	38	4,55	12 000	13 000	0,16	NU 1007 ECP	–
	72	17	56	48	6,1	11 000	12 000	0,29	* NU 207 ECP	J, M, ML
	72	17	56	48	6,1	11 000	12 000	0,30	* NJ 207 ECP	J, M, ML
	72	17	56	48	6,1	11 000	12 000	0,31	* NUP 207 ECP	J, M, ML
	72	17	56	48	6,1	11 000	12 000	0,30	* N 207 ECP	–
	72	23	69,5	63	8,15	11 000	12 000	0,40	* NU 2207 ECP	J, ML
	72	23	69,5	63	8,15	11 000	12 000	0,41	* NJ 2207 ECP	J, ML
	72	23	69,5	63	8,15	11 000	12 000	0,42	* NUP 2207 ECP	ML
	80	21	75	63	8,15	9 500	11 000	0,47	* NU 307 ECP	J, M, ML
	80	21	75	63	8,15	9 500	11 000	0,49	* NJ 307 ECP	J, M, ML
	80	21	75	63	8,15	9 500	11 000	0,50	* NUP 307 ECP	J, M, ML
	80	21	75	63	8,15	9 500	11 000	0,48	* N 307 ECP	–
	80	31	106	98	12,7	9 500	11 000	0,72	* NU 2307 ECP	J
	80	31	106	98	12,7	9 500	11 000	0,73	* NJ 2307 ECP	–
80	31	106	98	12,7	9 500	11 000	0,76	* NUP 2307 ECP	–	
100	25	76,5	69,5	9	8 000	9 500	1,00	NU 407	–	
100	25	76,5	69,5	9	8 000	9 500	1,05	NJ 407	–	
40	68	15	25,1	26	3	11 000	18 000	0,23	NU 1008 ML	–
	80	18	62	53	6,7	9 500	11 000	0,37	* NU 208 ECP	J, M, ML
	80	18	62	53	6,7	9 500	11 000	0,39	* NJ 208 ECP	J, M, ML
	80	18	62	53	6,7	9 500	11 000	0,40	* NUP 208 ECP	J, M, ML
	80	18	62	53	6,7	9 500	11 000	0,37	* N 208 ECP	–
	80	23	81,5	75	9,65	9 500	11 000	0,49	* NU 2208 ECP	J, ML
	80	23	81,5	75	9,65	9 500	11 000	0,50	* NJ 2208 ECP	J, ML
	80	23	81,5	75	9,65	9 500	11 000	0,51	* NUP 2208 ECP	J, ML
	90	23	93	78	10,2	8 000	9 500	0,65	* NU 308 ECP	J, M, ML
	90	23	93	78	10,2	8 000	9 500	0,67	* NJ 308 ECP	J, M, ML
	90	23	93	78	10,2	8 000	9 500	0,68	* NUP 308 ECP	M, ML
	90	23	93	78	10,2	8 000	9 500	0,65	* N 308 ECP	–

* SKF Explorer bearing

¹⁾ When ordering bearings with an alternative standard cage the suffix of the standard cage has to be replaced by the suffix of the cage in question, e.g. NU 207 ECP becomes NU 207 ECML (for speed ratings → page 517)

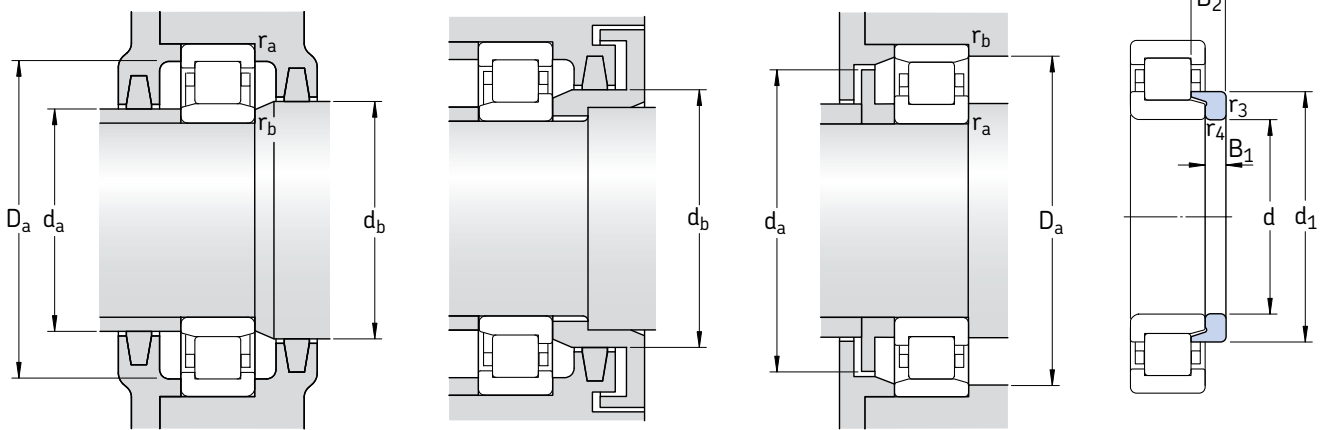

Angle ring

Dimensions							Abutment and fillet dimensions						Calculation factor k_r	Angle ring Designation	Mass	Dimensions	
d	d_1	D_1	F, E	$r_{1,2}$ min	$r_{3,4}$ min	$s^1)$	d_a min	d_a max	d_b, D_a min	D_a max	r_a max	r_b max				B_1	B_2
mm							mm						-	-	kg	mm	
35	-	54,5	42	1	0,6	1	38,2	41	44	56	1	0,6	0,1	-			
	48,1	60,7	44	1,1	0,6	1,3	39,2	42	46	65	1	0,6	0,15	HJ 207 EC	0,033	4	7
	48,1	60,7	44	1,1	0,6	1,3	42	42	50	65	1	0,6	0,15	HJ 207 EC	0,033	4	7
	48,1	60,7	44	1,1	0,6	-	42	-	50	65	1	0,6	0,15	-			
	48,1	-	64	1,1	0,6	1,3	42	62	66	67,8	1	0,6	0,15	-			
	-	60,7	44	1,1	0,6	2,8	39,2	42	46	65	1	0,6	0,2	-			
	48,1	60,7	44	1,1	0,6	2,8	42	42	50	65	1	0,6	0,2	-			
	48,1	60,7	44	1,1	0,6	-	42	-	48	65	1	0,6	0,2	-			
	51	66,3	46,2	1,5	1,1	1,2	42	44	48	71	1,5	1	0,15	HJ 307 EC	0,058	6	9,5
	51	66,3	46,2	1,5	1,1	1,2	44	44	53	71	1,5	1	0,15	HJ 307 EC	0,058	6	9,5
	51	66,3	46,2	1,5	1,1	-	44	-	53	71	1,5	1	0,15	-			
	51	-	70,2	1,5	1,1	1,2	44	68	72	73	1,5	1	0,15	-			
	-	66,3	46,2	1,5	1,1	2,7	42	44	48	71	1,5	1	0,25	-			
	51	66,3	46,2	1,5	1,1	2,7	44	44	53	71	1,5	1	0,25	-			
	51	66,3	46,2	1,5	1,1	-	44	-	53	71	1,5	1	0,25	-			
	-	76,1	53	1,5	1,5	1,7	46	50	55	89	1,5	1,5	0,15	-			
	59	76,1	53	1,5	1,5	1,7	46	50	61	89	1,5	1,5	0,15	-			
40	-	57,6	47	1	0,6	2,4	43,2	45	49	63,4	1	0,6	0,1	-			
	54	67,9	49,5	1,1	1,1	1,4	47	48	51	73	1	1	0,15	HJ 208 EC	0,047	5	8,5
	54	67,9	49,5	1,1	1,1	1,4	47	48	56	73	1	1	0,15	HJ 208 EC	0,047	5	8,5
	54	67,9	49,5	1,1	1,1	-	47	-	56	73	1	1	0,15	-			
	54	-	71,5	1,1	1,1	1,4	47	69	73	73	1	1	0,15	-			
	54	67,9	49,5	1,1	1,1	1,9	47	48	51	73	1	1	0,2	HJ 2208 EC	0,048	5	9
	54	67,9	49,5	1,1	1,1	1,9	47	48	56	73	1	1	0,2	HJ 2208 EC	0,048	5	9
	54	67,9	49,5	1,1	1,1	-	47	-	56	73	1	1	0,2	-			
	57,5	75,6	52	1,5	1,5	1,4	49	50	54	81	1,5	1,5	0,15	HJ 308 EC	0,084	7	11
	57,5	75,6	52	1,5	1,5	1,4	49	50	60	81	1,5	1,5	0,15	HJ 308 EC	0,084	7	11
	57,5	75,6	52	1,5	1,5	-	49	-	60	81	1,5	1,5	0,15	-			
	57,5	-	80	1,5	1,5	1,4	49	78	82	81	1,5	1,5	0,15	-			

¹⁾ Permissible axial displacement from the normal position of one bearing ring in relation to the other

Single row cylindrical roller bearings

d 40 – 50 mm

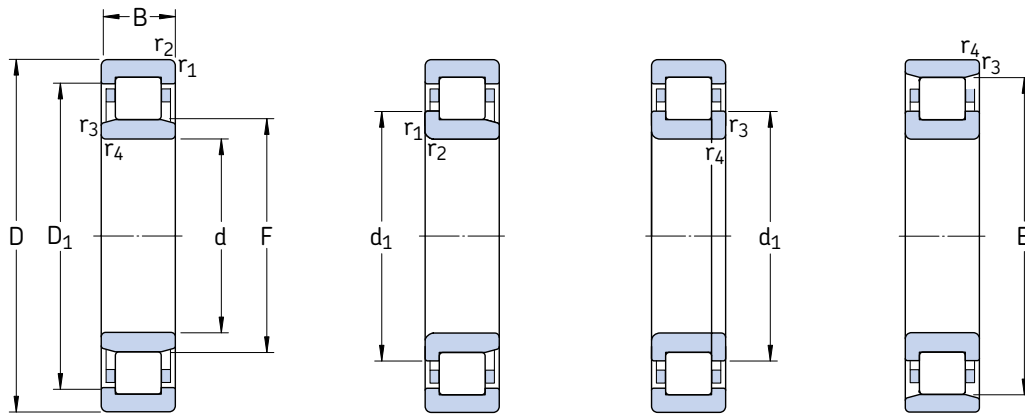

NU

NJ

NUP

N

Principal dimensions			Basic load ratings dynamic static		Fatigue load limit P_u	Speed ratings Reference speed Limiting speed		Mass Bearing with standard cage	Designations Bearing with standard cage	Alternative standard cage designs ¹⁾
d	D	B	C	C_0						
mm			kN		kN	r/min		kg	–	
40 cont.	90	33	129	120	15,3	8 000	9 500	0,94	* NU 2308 ECP	J, M, ML
	90	33	129	120	15,3	8 000	9 500	0,95	* NJ 2308 ECP	J, M, ML
	90	33	129	120	15,3	8 000	9 500	0,98	* NUP 2308 ECP	M, ML
	110	27	96,8	90	11,6	7 000	8 500	1,25	NU 408	–
	110	27	96,8	90	11,6	7 000	8 500	1,30	NJ 408	–
	45	75	16	44,6	52	6,3	9 500	11 000	0,26	NU 1009 ECP
	85	19	69,5	64	8,15	9 000	9 500	0,43	* NU 209 ECP	J, M, ML
	85	19	69,5	64	8,15	9 000	9 500	0,44	* NJ 209 ECP	J, M, ML
	85	19	69,5	64	8,15	9 000	9 500	0,45	* NUP 209 ECP	J, M, ML
	85	19	69,5	64	8,15	9 000	9 500	0,43	* N 209 ECP	–
	85	23	85	81,5	10,6	9 000	9 500	0,52	* NU 2209 ECP	J
	85	23	85	81,5	10,6	9 000	9 500	0,54	* NJ 2209 ECP	J
	85	23	85	81,5	10,6	9 000	9 500	0,55	* NUP 2209 ECP	–
	100	25	112	100	12,9	7 500	8 500	0,90	* NU 309 ECP	J, M, ML
	100	25	112	100	12,9	7 500	8 500	0,92	* NJ 309 ECP	J, M, ML
	100	25	112	100	12,9	7 500	8 500	0,95	* NUP 309 ECP	J, ML
	100	25	112	100	12,9	7 500	8 500	0,88	* N 309 ECP	–
	100	36	160	153	20	7 500	8 500	1,30	* NU 2309 ECP	ML
	100	36	160	153	20	7 500	8 500	1,33	* NJ 2309 ECP	ML
	100	36	160	153	20	7 500	8 500	1,36	* NUP 2309 ECP	ML
	120	29	106	102	13,4	6 700	7 500	1,64	NU 409	–
	120	29	106	102	13,4	6 700	7 500	1,67	NJ 409	–
50	80	16	46,8	56	6,7	9 000	9 500	0,27	NU 1010 ECP	–
	90	20	73,5	69,5	8,8	8 500	9 000	0,48	* NU 210 ECP	J, M, ML
	90	20	73,5	69,5	8,8	8 500	9 000	0,49	* NJ 210 ECP	J, M, ML
	90	20	73,5	69,5	8,8	8 500	9 000	0,51	* NUP 210 ECP	J, ML
	90	20	73,5	69,5	8,8	8 500	9 000	0,48	* N 210 ECP	–

* SKF Explorer bearing

¹⁾ When ordering bearings with an alternative standard cage the suffix of the standard cage has to be replaced by the suffix of the cage in question, e.g. NU 2308 ECP becomes NU 2308 ECML (for speed ratings → page 517)

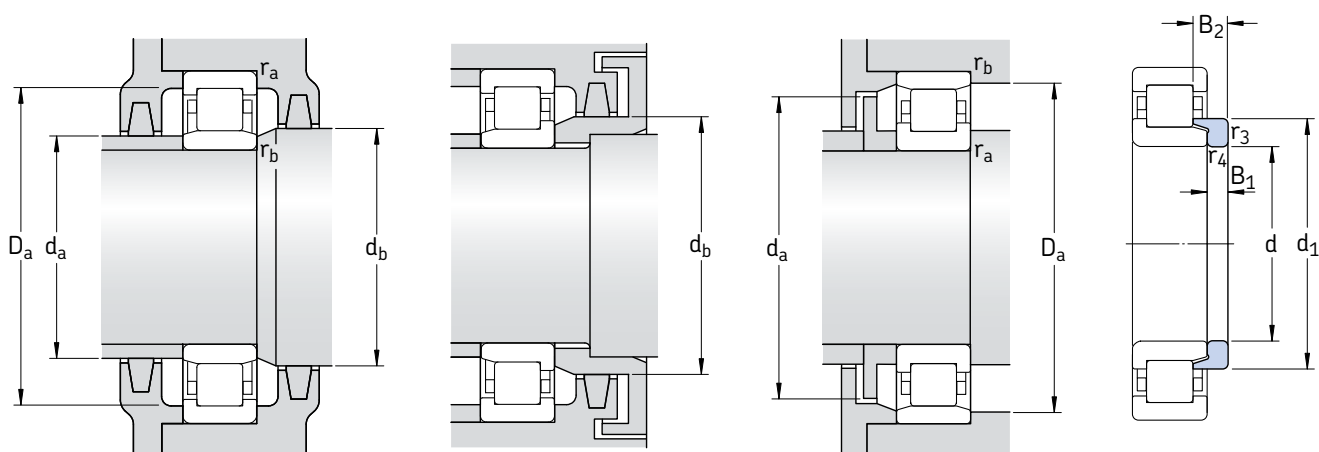

Angle ring

Dimensions							Abutment and fillet dimensions						Calculation factor	Angle ring	Mass	Dimensions	
d	d ₁	D ₁	F, E	r _{1,2} min	r _{3,4} min	s ¹⁾	d _a min	d _a max	d _b , D _a min	D _a max	r _a max	r _b max	k _r	Designation	kg	B ₁	B ₂
mm							mm						-	-	kg	mm	
40 cont.	-	75,6	52	1,5	1,5	2,9	49	50	54	81	1,5	1,5	0,25	-			
	57,5	75,6	52	1,5	1,5	2,9	49	50	60	81	1,5	1,5	0,25	-			
	57,5	75,6	52	1,5	1,5	-	49	-	60	81	1,5	1,5	0,25	-			
-	84,2	84,2	58	2	2	2,5	53	56	60	97	2	2	0,15	-			
	64,8	84,2	58	2	2	2,5	53	56	67	97	2	2	0,15	-			
45	-	65,3	52,5	1	0,6	0,9	48,2	51	54	70,4	1	0,6	0,1	-			
59	73	54,5	1,1	1,1	1,2	52	53	56	78	1	1	0,15	HJ 209 EC	0,052	5	8,5	
59	73	54,5	1,1	1,1	1,2	52	53	61	78	1	1	0,15	HJ 209 EC	0,052	5	8,5	
59	73	54,5	1,1	1,1	-	52	-	61	78	1	1	0,15	-				
59	-	76,5	1,1	1,1	1,2	52	74	78	78	1	1	0,15	-				
-	73	54,5	1,1	1,1	1,7	52	53	56	78	1	1	0,2	-				
59	73	54,5	1,1	1,1	1,7	52	53	56	78	1	1	0,2	-				
59	73	54,5	1,1	1,1	-	52	-	61	78	1	1	0,2	-				
64,4	83,8	58,5	1,5	1,5	1,7	54	56	61	91	1,5	1,5	0,15	HJ 309 EC	0,11	7	11,5	
64,4	83,8	58,5	1,5	1,5	1,7	54	56	67	91	1,5	1,5	0,15	HJ 309 EC	0,11	7	11,5	
64,4	83,8	58,5	1,5	1,5	-	54	-	67	91	1,5	1,5	0,15	-				
64,4	-	88,5	1,5	1,5	1,7	54	86	91	91	1,5	1,5	0,15	-				
-	83,8	58,5	1,5	1,5	3,2	54	56	61	91	1,5	1,5	0,25	-				
64,4	83,8	58,5	1,5	1,5	3,2	54	56	67	91	1,5	1,5	0,25	-				
64,4	83,8	58,5	1,5	1,5	-	54	-	67	91	1,5	1,5	0,25	-				
71,8	92,2	64,5	2	2	2,5	58	62	67	107	2	2	0,15	HJ 409	0,18	8	13,5	
71,8	92,2	64,5	2	2	2,5	58	62	74	107	2	2	0,15	HJ 409	0,18	8	13,5	
50	-	70	57,5	1	0,6	1	53,2	56	60	75,4	1	0,6	0,1	-			
64	78	59,5	1,1	1,1	1,5	57	57	62	83	1	1	0,15	HJ 210 EC	0,058	5	9	
64	78	59,5	1,1	1,1	1,5	57	57	66	83	1	1	0,15	HJ 210 EC	0,058	5	9	
64	78	59,5	1,1	1,1	-	57	-	66	83	1	1	0,15	-				
64	-	81,5	1,1	1,1	1,5	57	79	83	83	1	1	0,15	-				

¹⁾ Permissible axial displacement from the normal position of one bearing ring in relation to the other

Single row cylindrical roller bearings

d 50 – 55 mm

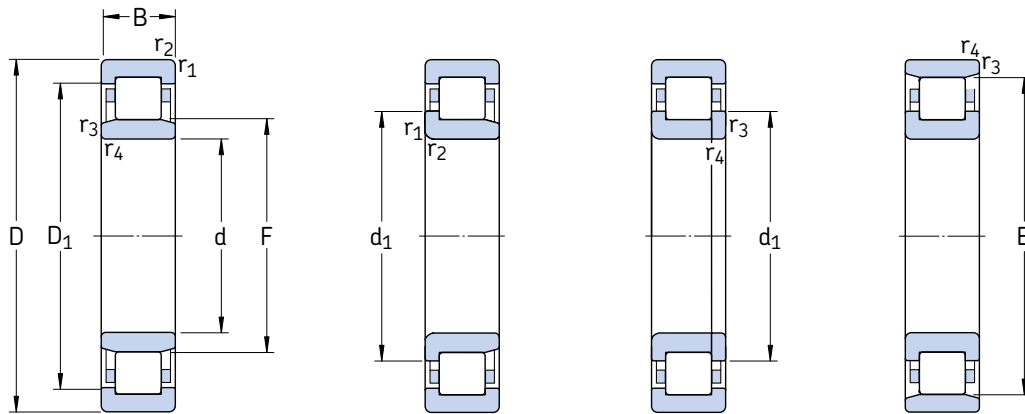

NU

NJ

NUP

N

Principal dimensions			Basic load ratings dynamic static		Fatigue load limit	Speed ratings Refer- ence speed Limiting speed		Mass Bearing with standard cage	Designations Bearing with standard cage cage	Alternative standard cage designs ¹⁾
d	D	B	C	C ₀	P _u			kg	–	
mm			kN		kN	r/min		kg	–	
50 cont.	90	23	90	88	11,4	8 500	9 000	0,56	* NU 2210 ECP	J, M, ML
	90	23	90	88	11,4	8 500	9 000	0,57	* NJ 2210 ECP	J, M, ML
	90	23	90	88	11,4	8 500	9 000	0,59	* NUP 2210 ECP	J, ML
	110	27	127	112	15	6 700	8 000	1,14	* NU 310 ECP	J, M, ML
	110	27	127	112	15	6 700	8 000	1,17	* NJ 310 ECP	J, M, ML
	110	27	127	112	15	6 700	8 000	1,20	* NUP 310 ECP	J, M, ML
	110	27	127	112	15	6 700	8 000	1,14	* N 310 ECP	M
	110	40	186	186	24,5	6 700	8 000	1,73	* NU 2310 ECP	ML
	110	40	186	186	24,5	6 700	8 000	1,77	* NJ 2310 ECP	ML
	110	40	186	186	24,5	6 700	8 000	1,80	* NUP 2310 ECP	ML
	130	31	130	127	16,6	6 000	7 000	2,00	NU 410	–
	130	31	130	127	16,6	6 000	7 000	2,05	NJ 410	–
55	90	18	57,2	69,5	8,3	8 000	8 500	0,39	NU 1011 ECP	–
	100	21	96,5	95	12,2	7 500	8 000	0,66	* NU 211 ECP	J, M, ML
	100	21	96,5	95	12,2	7 500	8 000	0,67	* NJ 211 ECP	J, M, ML
	100	21	96,5	95	12,2	7 500	8 000	0,69	* NUP 211 ECP	J, M, ML
	100	21	96,5	95	12,2	7 500	8 000	0,66	* N 211 ECP	M
	100	25	114	118	15,3	7 500	8 000	0,79	* NU 2211 ECP	J, M, ML
	100	25	114	118	15,3	7 500	8 000	0,81	* NJ 2211 ECP	J, M, ML
	100	25	114	118	15,3	7 500	8 000	0,82	* NUP 2211 ECP	J, ML
	120	29	156	143	18,6	6 000	7 000	1,45	* NU 311 ECP	J, M, ML
	120	29	156	143	18,6	6 000	7 000	1,50	* NJ 311 ECP	J, M, ML
	120	29	156	143	18,6	6 000	7 000	1,55	* NUP 311 ECP	J, M, ML
	120	29	156	143	18,6	6 000	7 000	1,45	* N 311 ECP	M
	120	43	232	232	30,5	6 000	7 000	2,20	* NU 2311 ECP	ML
	120	43	232	232	30,5	6 000	7 000	2,25	* NJ 2311 ECP	ML
	120	43	232	232	30,5	6 000	7 000	2,30	* NUP 2311 ECP	ML
	140	33	142	140	18,6	5 600	6 300	2,50	NU 411	–
	140	33	142	140	18,6	5 600	6 300	2,55	NJ 411	–

* SKF Explorer bearing

¹⁾ When ordering bearings with an alternative standard cage the suffix of the standard cage has to be replaced by the suffix of the cage in question, e.g. NU 2210 ECP becomes NU 2210 ECML (for speed ratings → page 517)

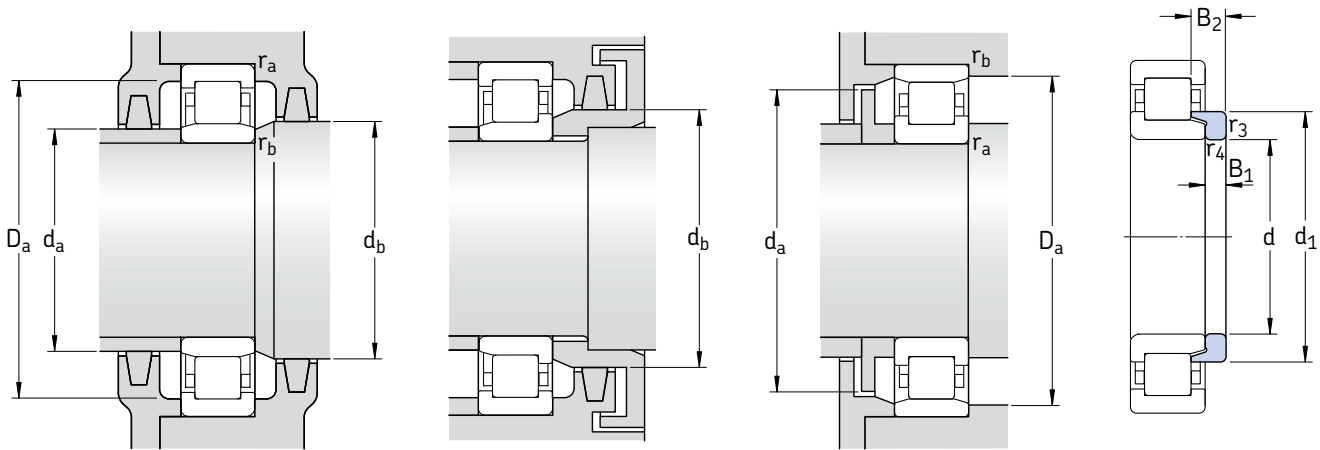

Angle ring

Dimensions							Abutment and fillet dimensions						Calculation factor k_r	Angle ring Designation	Mass	Dimensions	
d	d_1	D_1	F, E	$r_{1,2}$ min	$r_{3,4}$ min	$s^1)$	d_a min	d_a max	d_b, D_a min	D_a max	r_a max	r_b max				B_1	B_2
mm							mm						-	-	kg	mm	
50 cont.	-	78	59,5	1,1	1,1	1,5	57	57	62	83	1	1	0,2	-	-	-	-
	64	78	59,5	1,1	1,1	1,5	57	57	66	83	1	1	0,2	-	-	-	-
	64	78	59,5	1,1	1,1	-	57	-	66	83	1	1	0,2	-	-	-	-
	71,2	92,1	65	2	2	1,9	61	63	67	99	2	2	0,15	HJ 310 EC	0,14	8	13
	71,2	92,1	65	2	2	1,9	61	63	73	99	2	2	0,15	HJ 310 EC	0,14	8	13
	71,2	92,1	65	2	2	-	61	-	73	99	2	2	0,15	-	-	-	-
	71,2	-	97	2	2	1,9	61	95	99	99	2	2	0,15	-	-	-	-
	-	92,1	65	2	2	3,4	61	63	67	99	2	2	0,25	-	-	-	-
	71,2	92,1	65	2	2	3,4	61	63	73	99	2	2	0,25	-	-	-	-
	71,2	92,1	65	2	2	-	61	-	73	99	2	2	0,25	-	-	-	-
78,8	102	70,8	2,1	2,1	2,6	64	68	73	116	2	2	0,15	HJ 410	0,23	9	14,5	
	102	70,8	2,1	2,1	2,6	64	68	81	116	2	2	0,15	HJ 410	0,23	9	14,5	
55	-	79	64,5	1,1	1	0,5	59,6	63	67	84	1	1	0,1	-	-	-	-
70,8	86,3	66	1,5	1,1	1	62	64	68	91	1,5	1	0,15	HJ 211 EC	0,083	6	9,5	
70,8	86,3	66	1,5	1,1	1	64	64	73	91	1,5	1	0,15	HJ 211 EC	0,083	6	9,5	
70,8	86,3	66	1,5	1,1	-	64	-	73	91	1,5	1	0,15	-	-	-	-	
70,8	-	90	1,5	1,1	1	64	88	92	93	1,5	1	0,15	-	-	-	-	
70,8	86,3	66	1,5	1,1	1,5	62	64	68	91	1,5	1	0,2	HJ 2211 EC	0,085	6	10	
70,8	86,3	66	1,5	1,1	1,5	64	64	73	91	1,5	1	0,2	HJ 2211 EC	0,085	6	10	
70,8	86,3	66	1,5	1,1	-	64	-	73	91	1,5	1	0,2	-	-	-	-	
77,5	101	70,5	2	2	2	66	68	73	109	2	2	0,15	HJ 311 EC	0,19	9	14	
77,5	101	70,5	2	2	2	66	68	80	109	2	2	0,15	HJ 311 EC	0,19	9	14	
77,5	101	70,5	2	2	-	66	-	80	109	2	2	0,15	-	-	-	-	
77,5	-	106,5	2	2	2	66	104	109	109	2	2	0,15	-	-	-	-	
77,5	101	70,5	2	2	3,5	66	68	73	109	2	2	0,25	HJ 2311 EC	0,20	9	15,5	
77,5	101	70,5	2	2	3,5	66	68	80	109	2	2	0,25	HJ 2311 EC	0,20	9	15,5	
77,5	101	70,5	2	2	-	66	-	80	109	2	2	0,25	-	-	-	-	
85,2	108	77,2	2,1	2,1	2,6	69	74	79	126	2	2	0,15	-	-	-	-	
85,2	108	77,2	2,1	2,1	2,6	69	74	88	126	2	2	0,15	-	-	-	-	

¹⁾ Permissible axial displacement from the normal position of one bearing ring in relation to the other

Single row cylindrical roller bearings

d 60 – 65 mm

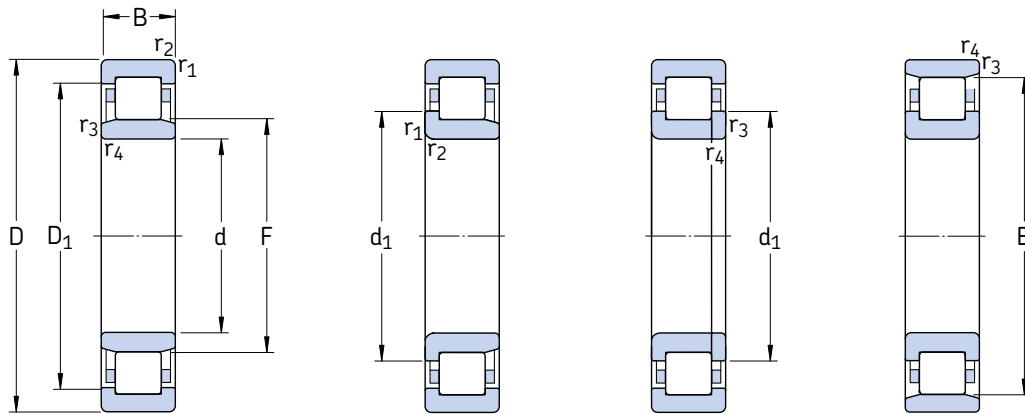

NU

NJ

NUP

N

Principal dimensions			Basic load ratings dynamic static		Fatigue load limit P_u	Speed ratings Refer- ence speed		Mass Bearing with standard cage	Designations Bearing with standard cage	Alternative standard cage designs ¹⁾
d	D	B	C	C_0						
mm			kN		kN	r/min		kg	–	
60	95	18	37,4	44	5,3	8 000	11 000	0,48	NU 1012 ML	–
	110	22	108	102	13,4	6 700	7 500	0,80	* NU 212 ECP	J, M, ML
	110	22	108	102	13,4	6 700	7 500	0,83	* NJ 212 ECP	J, M, ML
	110	22	108	102	13,4	6 700	7 500	0,86	* NUP 212 ECP	J, ML
	110	22	108	102	13,4	6 700	7 500	0,80	* N 212 ECP	M
	110	28	146	153	20	6 700	7 500	1,05	* NU 2212 ECP	J, M, ML
	110	28	146	153	20	6 700	7 500	1,10	* NJ 2212 ECP	J, M, ML
	110	28	146	153	20	6 700	7 500	1,15	* NUP 2212 ECP	J, ML
	130	31	173	160	20,8	5 600	6 700	1,77	* NU 312 ECP	J, M, ML
	130	31	173	160	20,8	5 600	6 700	1,83	* NJ 312 ECP	J, M, ML
	130	31	173	160	20,8	5 600	6 700	1,90	* NUP 312 ECP	J, M, ML
	130	31	173	160	20,8	5 600	6 700	1,80	* N 312 ECP	M
	130	46	260	265	34,5	5 600	6 700	2,75	* NU 2312 ECP	ML
	130	46	260	265	34,5	5 600	6 700	2,80	* NJ 2312 ECP	ML
	130	46	260	265	34,5	5 600	6 700	2,85	* NUP 2312 ECP	ML
	150	35	168	173	22	5 000	6 000	3,00	NU 412	–
	150	35	168	173	22	5 000	6 000	3,10	NJ 412	–
65	100	18	62,7	81,5	9,8	7 000	7 500	0,45	NU 1013 ECP	–
	120	23	122	118	15,6	6 300	6 700	1,03	* NU 213 ECP	J, M, ML
	120	23	122	118	15,6	6 300	6 700	1,07	* NJ 213 ECP	J, M, ML
	120	23	122	118	15,6	6 300	6 700	1,10	* NUP 213 ECP	J, ML
	120	23	122	118	15,6	6 300	6 700	1,05	* N 213 ECP	–
	120	31	170	180	24	6 300	6 700	1,40	* NU 2213 ECP	J
	120	31	170	180	24	6 300	6 700	1,45	* NJ 2213 ECP	J
	120	31	170	180	24	6 300	6 700	1,50	* NUP 2213 ECP	–
	140	33	212	196	25,5	5 300	6 000	2,20	* NU 313 ECP	J, M, ML
	140	33	212	196	25,5	5 300	6 000	2,30	* NJ 313 ECP	J, M, ML
	140	33	212	196	25,5	5 300	6 000	2,35	* NUP 313 ECP	J, ML
	140	33	212	196	25,5	5 300	6 000	2,20	* N 313 ECP	M

* SKF Explorer bearing

¹⁾ When ordering bearings with an alternative standard cage the suffix of the standard cage has to be replaced by the suffix of the cage in question, e.g. NU 212 ECP becomes NU 212 ECML (for speed ratings → page 517)

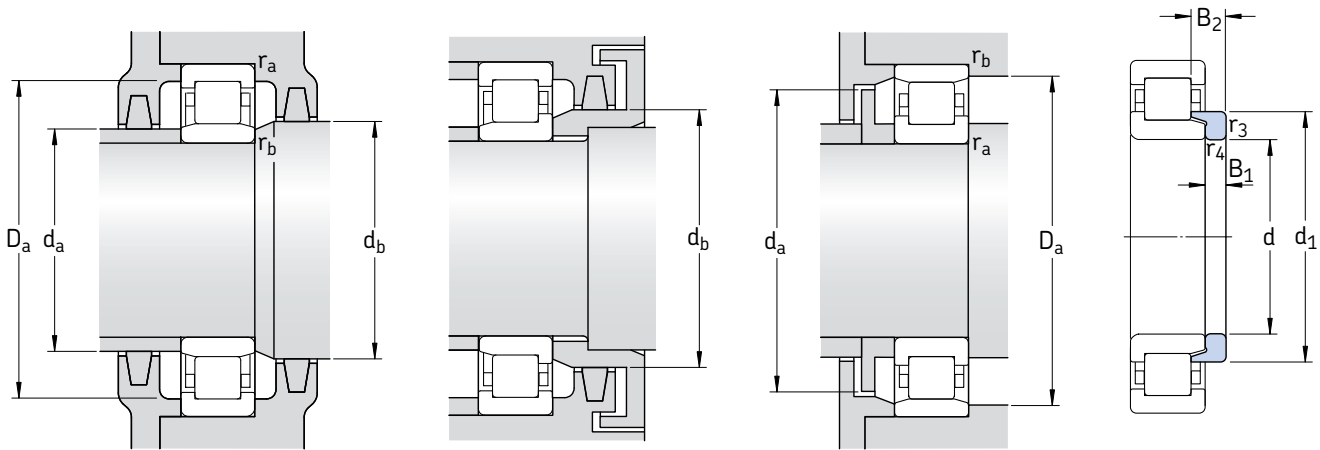

Angle ring

Dimensions							Abutment and fillet dimensions						Calculation factor	Angle ring	Mass	Dimensions	
d	d ₁	D ₁	F, E	r _{1,2}	r _{3,4}	s ¹⁾	d _a	d _a	d _b , D _a	D _a	r _a	r _b	k _r	Designation	kg	B ₁	B ₂
mm							mm						-	-	kg	mm	
60	-	81,6	69,5	1,1	1	2,9	64,6	68	72	89	1	1	0,1	-			
	77,5	95,7	72	1,5	1,5	1,4	69	70	74	101	1,5	1,5	0,15	HJ 212 EC	0,10	6	10
	77,5	95,7	72	1,5	1,5	1,4	69	70	80	101	1,5	1,5	0,15	HJ 212 EC	0,10	6	10
	77,5	95,7	72	1,5	1,5	-	69	-	80	101	1,5	1,5	0,15	-			
	77,5	-	100	1,5	1,5	1,4	69	98	101	101	1,5	1,5	0,15	-			
	77,5	95,7	72	1,5	1,5	1,4	69	70	74	101	1,5	1,5	0,2	HJ 212 EC	0,10	6	10
	77,5	95,7	72	1,5	1,5	1,4	69	70	80	101	1,5	1,5	0,2	HJ 212 EC	0,10	6	10
	77,5	95,7	72	1,5	1,5	-	69	-	80	101	1,5	1,5	0,2	-			
	84,3	110	77	2,1	2,1	2,1	72	74	79	118	2	2	0,15	HJ 312 EC	0,22	9	14,5
	84,3	110	77	2,1	2,1	2,1	72	74	87	118	2	2	0,15	HJ 312 EC	0,22	9	14,5
	84,3	110	77	2,1	2,1	-	72	-	87	118	2	2	0,15	-			
	84,3	-	115	2,1	2,1	2,1	72	112	118	118	2	2	0,15	-			
	84,3	110	77	2,1	2,1	3,6	72	74	79	118	2	2	0,25	HJ 2312 EC	0,24	9	16
	84,3	110	77	2,1	2,1	3,6	72	74	87	118	2	2	0,25	HJ 2312 EC	0,24	9	16
	84,3	110	77	2,1	2,1	-	72	-	87	118	2	2	0,25	-			
	-	117	83	2,1	2,1	2,5	74	80	85	136	2	2	0,15	-			
	91,8	117	83	2,1	2,1	2,5	74	80	94	136	2	2	0,15	-			
65	-	88,5	74	1,1	1	1	69,6	72	77	94	1	1	0,1	-			
	84,4	104	78,5	1,5	1,5	1,4	74	76	81	111	1,5	1,5	0,15	HJ 213 EC	0,12	6	10
	84,4	104	78,5	1,5	1,5	1,4	74	76	87	111	1,5	1,5	0,15	HJ 213 EC	0,12	6	10
	84,4	104	78,5	1,5	1,5	-	74	-	87	111	1,5	1,5	0,15	-			
	84,4	-	108,5	1,5	1,5	1,4	74	106	111	111	1,5	1,5	0,15	-			
	84,4	104	78,5	1,5	1,5	1,9	74	76	81	111	1,5	1,5	0,2	HJ 2213 EC	0,13	6	10,5
	84,4	104	78,5	1,5	1,5	1,9	74	76	87	111	1,5	1,5	0,2	HJ 2213 EC	0,13	6	10,5
	84,4	104	78,5	1,5	1,5	-	74	-	87	111	1,5	1,5	0,2	-			
	90,5	119	82,5	2,1	2,1	2,2	77	80	85	128	2	2	0,15	HJ 313 EC	0,27	10	15,5
	90,5	119	82,5	2,1	2,1	2,2	77	80	93	128	2	2	0,15	HJ 313 EC	0,27	10	15,5
	90,5	119	82,5	2,1	2,1	-	77	-	93	128	2	2	0,15	-			
	90,5	-	124,5	2,1	2,1	2,2	77	122	127	128	2	2	0,15	-			

¹⁾ Permissible axial displacement from the normal position of one bearing ring in relation to the other

Single row cylindrical roller bearings

d 65 – 75 mm

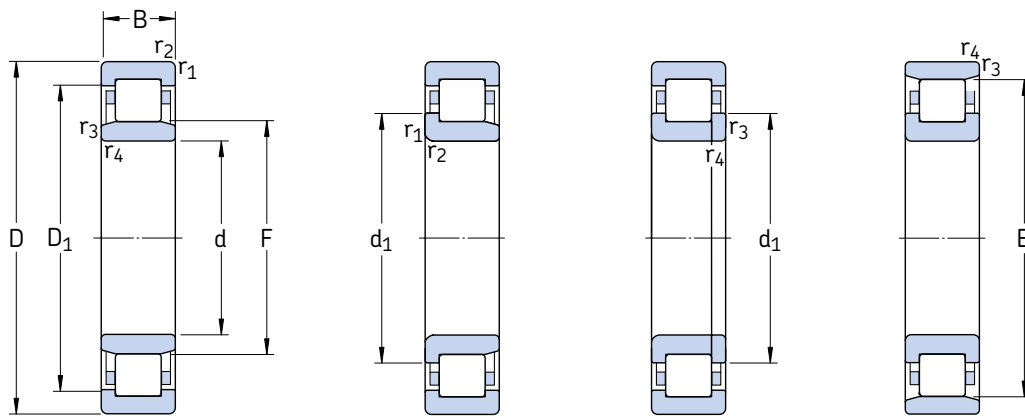

NU

NJ

NUP

N

Principal dimensions			Basic load ratings dynamic static		Fatigue load limit P_u	Speed ratings Reference speed Limiting speed		Mass Bearing with standard cage	Designations Bearing with standard cage	Alternative standard cage designs ¹⁾
d	D	B	C	C_0						
mm			kN		kN	r/min		kg	–	
65 cont.	140	48	285	290	38	5 300	6 000	3,20	* NU 2313 ECP	ML
	140	48	285	290	38	5 300	6 000	3,35	* NJ 2313 ECP	ML
	140	48	285	290	38	5 300	6 000	3,50	* NUP 2313 ECP	ML
	160	37	183	190	24	4 800	5 600	3,60	NU 413	–
	160	37	183	190	24	4 800	5 600	3,65	NJ 413	–
	70	110	20	76,5	93	12	6 300	7 000	0,62	NU 1014 ECP
	125	24	137	137	18	6 000	6 300	1,15	* NU 214 ECP	J, M, ML
	125	24	137	137	18	6 000	6 300	1,15	* NJ 214 ECP	J, M, ML
	125	24	137	137	18	6 000	6 300	1,20	* NUP 214 ECP	M, ML
	125	24	137	137	18	6 000	6 300	1,15	* N 214 ECP	–
	125	31	180	193	25,5	6 000	6 300	1,50	* NU 2214 ECP	J, M, ML
	125	31	180	193	25,5	6 000	6 300	1,55	* NJ 2214 ECP	M, ML
	125	31	180	193	25,5	6 000	6 300	1,55	* NUP 2214 ECP	M, ML
	150	35	236	228	29	4 800	5 600	2,70	* NU 314 ECP	J, M, ML
	150	35	236	228	29	4 800	5 600	2,90	* NJ 314 ECP	J, M, ML
	150	35	236	228	29	4 800	5 600	2,85	* NUP 314 ECP	M, ML
	150	35	236	228	29	4 800	5 600	2,70	* N 314 ECP	M
	150	51	315	325	41,5	4 800	5 600	3,90	* NU 2314 ECP	ML
	150	51	315	325	41,5	4 800	5 600	4,00	* NJ 2314 ECP	ML
	150	51	315	325	41,5	4 800	5 600	4,10	* NUP 2314 ECP	ML
	180	42	229	240	30	4 300	5 000	5,35	NU 414	–
	180	42	229	240	30	4 300	5 000	5,45	NJ 414	–
75	115	20	58,3	71	8,5	6 700	10 000	0,75	NU 1015 ML	–
	130	25	150	156	20,4	5 600	6 000	1,25	* NU 215 ECP	J, M, ML
	130	25	150	156	20,4	5 600	6 000	1,30	* NJ 215 ECP	J, M, ML
	130	25	150	156	20,4	5 600	6 000	1,35	* NUP 215 ECP	M, ML
	130	25	150	156	20,4	5 600	6 000	1,20	* N 215 ECP	–

* SKF Explorer bearing

¹⁾ When ordering bearings with an alternative standard cage the suffix of the standard cage has to be replaced by the suffix of the cage in question, e.g. NU 2313 ECP becomes NU 2313 ECML (for speed ratings → page 517)

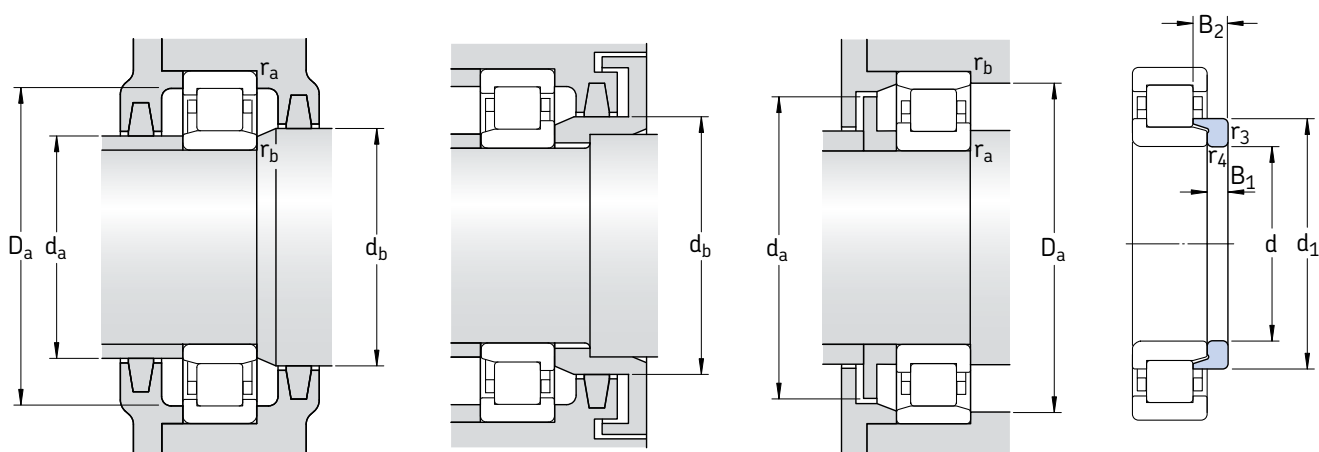

Angle ring

Dimensions							Abutment and fillet dimensions						Calculation factor	Angle ring Designation	Mass	Dimensions B ₁ B ₂	
d	d ₁	D ₁	F, E	r _{1,2} min	r _{3,4} min	s ¹⁾	d _a min	d _a max	d _b , D _a min	D _a max	r _a max	r _b max	k _r		kg	B ₁	B ₂
mm																	
65 cont.	90,5	119	82,5	2,1	2,1	4,7	77	80	85	128	2	2	0,25	HJ 2313 EC	0,30	10	18
	90,5	119	82,5	2,1	2,1	4,7	77	80	93	128	2	2	0,25	HJ 2313 EC	0,30	10	18
	90,5	119	82,5	2,1	2,1	–	77	–	93	128	2	2	0,25	–			
	98,5	125	89,3	2,1	2,1	2,6	79	86	92	146	2	2	0,15	HJ 413	0,42	11	18
	98,5	125	89,3	2,1	2,1	2,6	79	86	92	146	2	2	0,15	HJ 413	0,42	11	18
70	84	97,5	79,5	1,1	1	1,3	74,6	78	82	104	1	1	0,1	HJ 1014 EC	0,082	5	10
	89,4	109	83,5	1,5	1,5	1,2	79	81	86	116	1,5	1,5	0,15	HJ 214 EC	0,15	7	11
	89,4	109	83,5	1,5	1,5	1,2	79	81	92	116	1,5	1,5	0,15	HJ 214 EC	0,15	7	11
	89,4	109	83,5	1,5	1,5	–	79	–	92	116	1,5	1,5	0,15	–			
	89,4	–	113,5	1,5	1,5	1,2	79	111	116	116	1,5	1,5	0,15	–			
	89,4	109	83,5	1,5	1,5	1,7	79	81	86	116	1,5	1,5	0,2	HJ 2214 EC	0,16	7	11,5
	89,4	109	83,5	1,5	1,5	1,7	79	81	92	116	1,5	1,5	0,2	HJ 2214 EC	0,16	7	11,5
	89,4	109	83,5	1,5	1,5	–	79	–	92	116	1,5	1,5	0,2	–			
	97,3	127	89	2,1	2,1	1,8	82	86	91	138	2	2	0,15	HJ 314 EC	0,32	10	15,5
	97,3	127	89	2,1	2,1	1,8	82	86	100	138	2	2	0,15	HJ 314 EC	0,32	10	15,5
	97,3	127	89	2,1	2,1	–	82	–	100	138	2	2	0,15	–			
	97,3	–	133	2,1	2,1	1,8	82	130	136	138	2	2	0,15	–			
97,3	127	89	2,1	2,1	4,8	82	86	91	138	2	2	0,25	HJ 2314 EC	0,34	10	18,5	
97,3	127	89	2,1	2,1	4,8	82	86	100	138	2	2	0,25	HJ 2314 EC	0,34	10	18,5	
97,3	127	89	2,1	2,1	–	82	–	100	138	2	2	0,25	–				
110	140	100	3	3	3,5	86	97	102	164	2,5	2,5	0,15	HJ 414	0,61	12	20	
110	140	100	3	3	3,5	86	97	113	164	2,5	2,5	0,15	HJ 414	0,61	12	20	
75	–	101	85	1,1	1	3	79,6	83	87	109	1	1	0,1	–			
	94,3	114	88,5	1,5	1,5	1,2	84	86	91	121	1,5	1,5	0,15	HJ 215 EC	0,16	7	11
	94,3	114	88,5	1,5	1,5	1,2	84	86	97	121	1,5	1,5	0,15	HJ 215 EC	0,16	7	11
	94,3	114	88,5	1,5	1,5	–	84	–	97	121	1,5	1,5	0,15	–			
	94,3	–	118,5	1,5	1,5	1,2	84	116	121	121	1,5	1,5	0,15	–			

¹⁾ Permissible axial displacement from the normal position of one bearing ring in relation to the other

Single row cylindrical roller bearings

d 75 – 80 mm

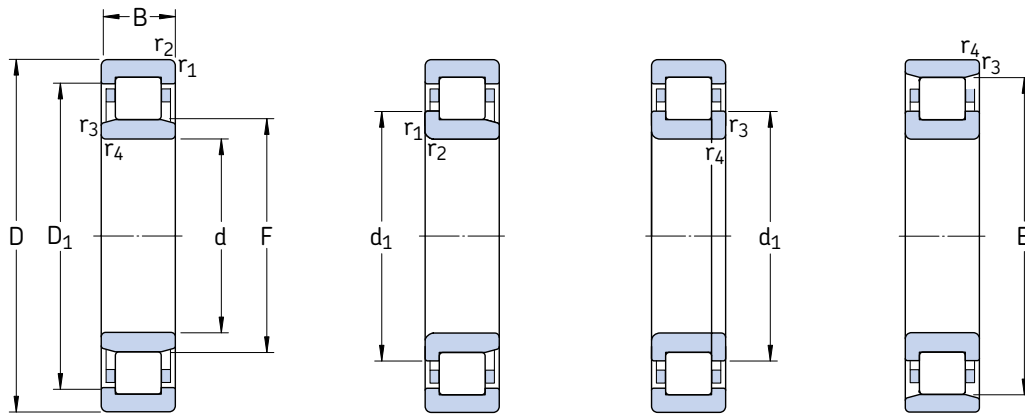

NU

NJ

NUP

N

Principal dimensions			Basic load ratings dynamic static		Fatigue load limit P_u	Speed ratings Reference speed Limiting speed		Mass Bearing with standard cage	Designations Bearing with standard cage	Alternative standard cage designs ¹⁾
d	D	B	C	C_0						
mm			kN		kN	r/min		kg	–	
75 cont.	130	31	186	208	27	5 600	6 000	1,60	* NU 2215 ECP	J, ML
	130	31	186	208	27	5 600	6 000	1,60	* NJ 2215 ECP	J, ML
	130	31	186	208	27	5 600	6 000	1,65	* NUP 2215 ECP	J, ML
	160	37	280	265	33,5	4 500	5 300	3,30	* NU 315 ECP	J, M, ML
	160	37	280	265	33,5	4 500	5 300	3,35	* NJ 315 ECP	J, M, ML
	160	37	280	265	33,5	4 500	5 300	3,45	* NUP 315 ECP	M, ML
	160	37	280	265	33,5	4 500	5 300	3,30	* N 315 ECP	M
	160	55	380	400	50	4 500	5 300	4,80	* NU 2315 ECP	J, ML
	160	55	380	400	50	4 500	5 300	5,00	* NJ 2315 ECP	ML
	160	55	380	400	50	4 500	5 300	5,20	* NUP 2315 ECP	ML
	190	45	264	280	34	4 000	4 800	6,20	NU 415	–
	190	45	264	280	34	4 000	4 800	6,40	NJ 415	–
80	125	22	66	81,5	10,4	6 300	6 300	1,00	NU 1016	–
	125	22	99	127	16,3	5 600	9 500	1,10	NJ 1016 ECML	–
	140	26	160	166	21,2	5 300	5 600	1,55	* NU 216 ECP	J, M, ML
	140	26	160	166	21,2	5 300	5 600	1,60	* NJ 216 ECP	J, M, ML
	140	26	160	166	21,2	5 300	5 600	1,65	* NUP 216 ECP	ML
	140	26	160	166	21,2	5 300	5 600	1,55	* N 216 ECP	–
	140	33	212	245	31	5 300	5 600	2,00	* NU 2216 ECP	J, M, ML
	140	33	212	245	31	5 300	5 600	2,05	* NJ 2216 ECP	J, M, ML
	140	33	212	245	31	5 300	5 600	2,10	* NUP 2216 ECP	M, ML
	170	39	300	290	36	4 300	5 000	3,90	* NU 316 ECP	J, M, ML
	170	39	300	290	36	4 300	5 000	4,00	* NJ 316 ECP	J, M, ML
	170	39	300	290	36	4 300	5 000	4,10	* NUP 316 ECP	M, ML
	170	39	300	290	36	4 300	5 000	3,90	* N 316 ECP	M
	170	58	415	440	55	4 300	5 000	5,85	* NU 2316 ECP	M, ML
	170	58	415	440	55	4 300	5 000	5,95	* NJ 2316 ECP	M, ML
	170	58	415	440	55	4 300	5 000	6,05	* NUP 2316 ECP	M, ML
	200	48	303	320	39	3 800	4 500	7,30	NU 416	–
	200	48	303	320	39	3 800	4 500	8,05	NJ 416	–

* SKF Explorer bearing

¹⁾ When ordering bearings with an alternative standard cage the suffix of the standard cage has to be replaced by the suffix of the cage in question, e.g. NU 2215 ECP becomes NU 2215 ECML (for speed ratings → page 517)

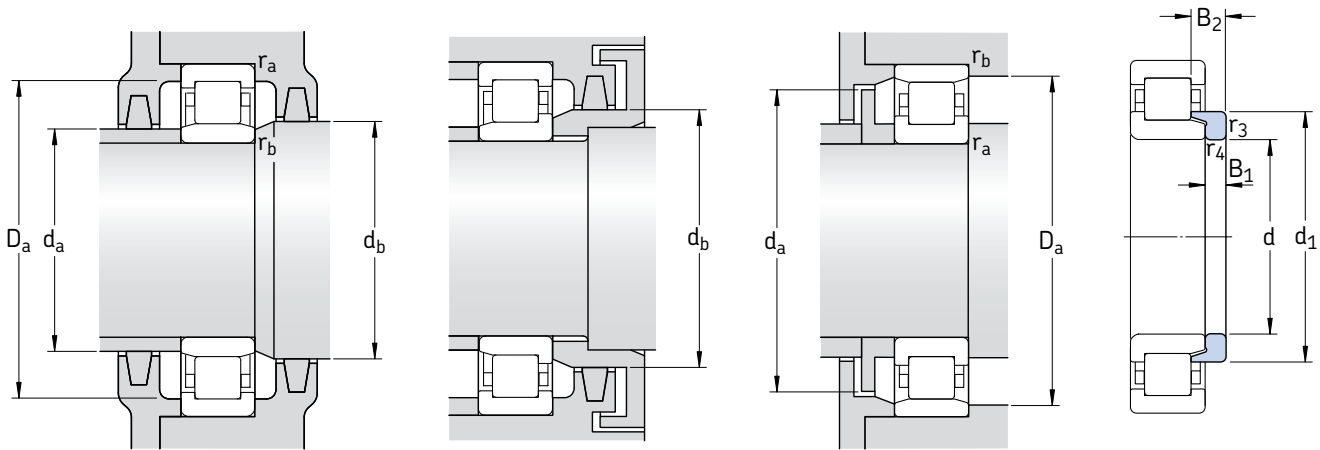

Angle ring

Dimensions							Abutment and fillet dimensions						Calculation factor	Angle ring Designation	Mass	Dimensions B ₁ B ₂	
d	d ₁	D ₁	F, E	r _{1,2} min	r _{3,4} min	s ¹⁾	d _a min	d _a max	d _b , D _a min	D _a max	r _a max	r _b max	k _r		kg	B ₁	B ₂
mm																	
75	-	114	88,5	1,5	1,5	1,7	84	86	91	121	1,5	1,5	0,2	-			
	cont. 94,3	114	88,5	1,5	1,5	1,7	84	86	97	121	1,5	1,5	0,2	-			
	94,3	114	88,5	1,5	1,5	-	84	-	97	121	1,5	1,5	0,2	-			
	104	136	95	2,1	2,1	1,8	87	92	97	148	2	2	0,15	HJ 315 EC	0,39	11	16,5
	104	136	95	2,1	2,1	1,8	87	92	107	148	2	2	0,15	HJ 315 EC	0,39	11	16,5
	104	136	95	2,1	2,1	-	87	-	107	148	2	2	0,15	-			
	104	-	143	2,1	2,1	1,8	87	140	146	148	2	2	0,15	-			
	104	136	95	2,1	2,1	4,8	87	92	97	148	2	2	0,25	HJ 2315 EC	0,42	11	19,5
	104	136	95	2,1	2,1	4,8	87	92	107	148	2	2	0,25	HJ 2315 EC	0,42	11	19,5
	104	136	95	2,1	2,1	-	87	-	107	148	2	2	0,25	-			
	116	148	104,5	3	3	3,8	91	101	107	174	2,5	2,5	0,15	HJ 415	0,71	13	21,5
	116	148	104,5	3	3	3,8	91	101	119	174	2,5	2,5	0,15	HJ 415	0,71	13	21,5
80	-	109	91,5	1,1	1	3,3	86	90	94	119	1	1	0,1	-			
	96,2	111	91,5	1,1	1	1,5	86	90	94	119	1	1	0,1	-			
	101	123	95,3	2	2	1,4	91	93	98	129	2	2	0,15	HJ 216 EC	0,21	8	12,5
	101	123	95,3	2	2	1,4	91	93	104	129	2	2	0,15	HJ 216 EC	0,21	8	12,5
	101	123	95,3	2	2	-	91	-	104	129	2	2	0,15	-			
	101	-	127,3	2	2	1,4	91	125	129	129	2	2	0,15	-			
	101	123	95,3	2	2	1,4	91	93	98	129	2	2	0,2	HJ 216 EC	0,21	8	12,5
	101	123	95,3	2	2	1,4	91	93	104	129	2	2	0,2	HJ 216 EC	0,21	8	12,5
	101	123	95,3	2	2	-	91	-	104	129	2	2	0,2	-			
	110	144	101	2,1	2,1	2,1	92	98	104	158	2	2	0,15	HJ 316 EC	0,44	11	17
	110	144	101	2,1	2,1	2,1	92	98	113	158	2	2	0,15	HJ 316 EC	0,44	11	17
	110	144	101	2,1	2,1	-	92	-	113	158	2	2	0,15	-			
	110	-	151	2,1	2,1	2,1	92	148	154	158	2	2	0,15	-			
	110	144	101	2,1	2,1	5,1	92	98	104	158	2	2	0,25	HJ 2316 EC	0,48	11	20
	110	144	101	2,1	2,1	5,1	92	98	113	158	2	2	0,25	HJ 2316 EC	0,48	11	20
	110	144	101	2,1	2,1	-	92	-	113	158	2	2	0,25	-			
	122	157	110	3	3	3,7	96	106	113	184	2,5	2,5	0,15	HJ 416	0,78	13	22
	122	157	110	3	3	3,7	96	106	125	184	2,5	2,5	0,15	HJ 416	0,78	13	22

¹⁾ Permissible axial displacement from the normal position of one bearing ring in relation to the other

Single row cylindrical roller bearings

d 85 – 90 mm

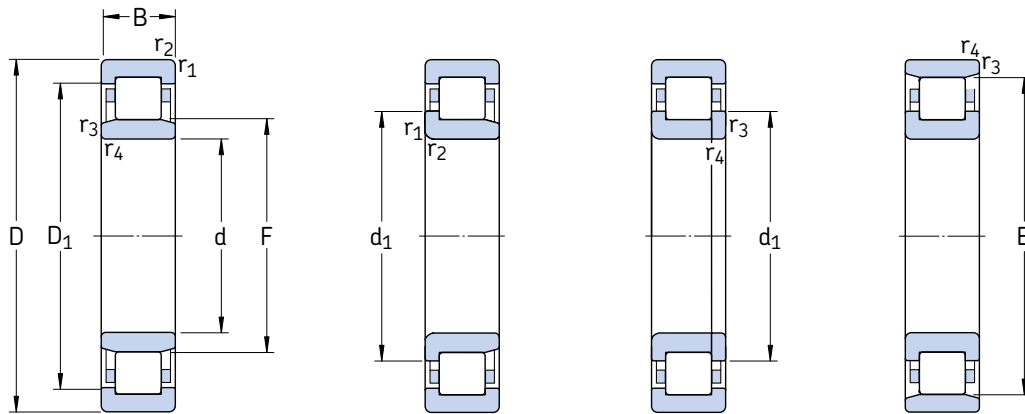

NU

NJ

NUP

N

Principal dimensions			Basic load ratings dynamic static		Fatigue load limit P_u	Speed ratings Reference speed Limiting speed		Mass Bearing with standard cage	Designations Bearing with standard cage	Alternative standard cage designs ¹⁾
d	D	B	C	C_0						
mm			kN		kN	r/min		kg	–	
85	130	22	68,2	86,5	10,8	6 000	9 000	1,05	NU 1017 ML	–
	150	28	190	200	24,5	4 800	5 300	1,90	* NU 217 ECP	J, M, ML
	150	28	190	200	24,5	4 800	5 300	1,95	* NJ 217 ECP	J, M, ML
	150	28	190	200	24,5	4 800	5 300	2,00	* NUP 217 ECP	J, ML
	150	28	190	200	24,5	4 800	5 300	1,90	* N 217 ECP	M
	150	36	250	280	34,5	4 800	5 300	2,50	* NU 2217 ECP	J, M, ML
	150	36	250	280	34,5	4 800	5 300	2,55	* NJ 2217 ECP	J, M, ML
	150	36	250	280	34,5	4 800	5 300	2,60	* NUP 2217 ECP	ML
	180	41	340	335	41,5	4 000	4 800	4,60	* NU 317 ECP	J, M
	180	41	340	335	41,5	4 000	4 800	4,75	* NJ 317 ECP	J, M
	180	41	340	335	41,5	4 000	4 800	4,90	* NUP 317 ECP	J, M
	180	41	340	335	41,5	4 000	4 800	4,55	* N 317 ECP	M
	180	60	455	490	60	4 000	4 800	6,85	* NU 2317 ECP	J, ML
	180	60	455	490	60	4 000	4 800	7,00	* NJ 2317 ECP	ML
	180	60	455	490	60	4 000	4 800	7,15	* NUP 2317 ECP	ML
	210	52	319	335	39	3 600	4 300	9,70	NU 417	–
	210	52	319	335	39	3 800	4 300	8,90	NJ 417	–
90	140	24	80,9	104	12,7	5 600	8 500	1,35	NU 1018 ML	–
	160	30	208	220	27	4 500	5 000	2,30	* NU 218 ECP	J, M, ML
	160	30	208	220	27	4 500	5 000	2,40	* NJ 218 ECP	J, M, ML
	160	30	208	220	27	4 500	5 000	2,45	* NUP 218 ECP	M, ML
	160	30	208	220	27	4 500	5 000	2,30	* N 218 ECP	M
	160	40	280	315	39	4 500	5 000	3,15	* NU 2218 ECP	J, M, ML
	160	40	280	315	39	4 500	5 000	3,25	* NJ 2218 ECP	M, ML
	160	40	280	315	39	4 500	5 000	3,30	* NUP 2218 ECP	–

* SKF Explorer bearing

¹⁾ When ordering bearings with an alternative standard cage the suffix of the standard cage has to be replaced by the suffix of the cage in question, e.g. NU 217 ECP becomes NU 217 ECML (for speed ratings → page 517)

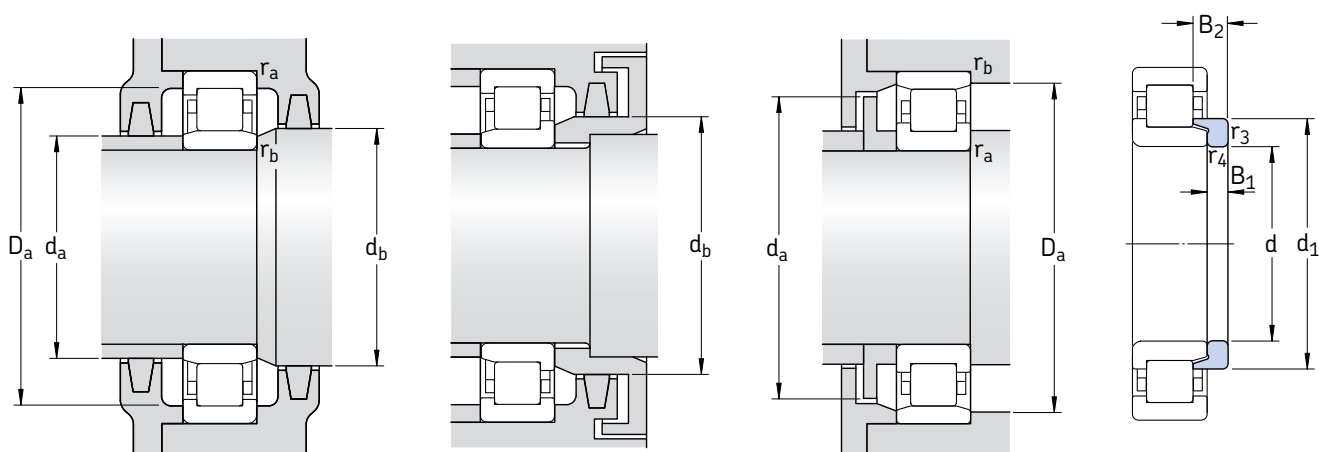

Angle ring

Dimensions							Abutment and fillet dimensions						Calculation factor	Angle ring Designation	Mass	Dimensions	
d	d ₁	D ₁	F, E	r _{1,2}	r _{3,4}	s ¹⁾	d _a	d _a	d _b , D _a	D _a	r _a	r _b	k _r		kg	B ₁	B ₂
							mm						-	-		mm	
85	-	114	96,5	1,1	1	3,3	89,6	95	99	124	1	1	0,1	-			
	107	131	100,5	2	2	1,5	96	98	103	139	2	2	0,15	HJ 217 EC	0,24	8	12,5
	107	131	100,5	2	2	1,5	96	98	110	139	2	2	0,15	HJ 217 EC	0,24	8	12,5
	107	131	100,5	2	2	-	96	-	110	139	2	2	0,15	-			
	107	-	136,5	2	2	1,5	96	134	139	139	2	2	0,15	-			
	-	131	100,5	2	2	2	96	98	103	139	2	2	0,2	-			
	107	131	100,5	2	2	2	96	98	110	139	2	2	0,2	-			
	107	131	100,5	2	2	-	96	-	110	139	2	2	0,2	-			
	117	153	108	3	3	2,3	99	105	111	166	2,5	2,5	0,15	HJ 317 EC	0,55	12	18,5
	117	153	108	3	3	2,3	99	105	120	166	2,5	2,5	0,15	HJ 317 EC	0,55	12	18,5
	117	153	108	3	3	-	99	-	120	166	2,5	2,5	0,15	-			
	117	-	160	3	3	2,3	99	157	163	166	2,5	2,5	0,15	-			
	117	153	108	3	3	5,8	99	105	111	166	2,5	2,5	0,25	HJ 2317 EC	0,60	12	22
	117	153	108	3	3	5,8	99	105	120	166	2,5	2,5	0,25	HJ 2317 EC	0,60	12	22
	117	153	108	3	3	-	99	-	120	166	2,5	2,5	0,25	-			
	126	163	113	4	4	3,8	105	109	116	190	3	3	0,15	HJ 417	0,88	14	24
	126	163	113	4	4	3,8	105	109	129	190	3	3	0,15	HJ 417	0,88	14	24
90	-	122	103	1,5	1,1	3,5	96	101	106	133	1,5	1	0,1	-			
	114	140	107	2	2	1,8	101	104	110	149	2	2	0,15	HJ 218 EC	0,31	9	14
	114	140	107	2	2	1,8	101	104	117	149	2	2	0,15	HJ 218 EC	0,31	9	14
	114	140	107	2	2	-	101	-	117	149	2	2	0,15	-			
	114	-	145	2	2	1,8	101	142	148	149	2	2	0,15	-			
	114	140	107	2	2	2,6	101	104	110	149	2	2	0,2	HJ 2218 EC	0,33	9	15
	114	140	107	2	2	2,6	101	104	117	149	2	2	0,2	HJ 2218 EC	0,33	9	15
	114	140	107	2	2	-	101	-	117	149	2	2	0,2	-			

¹⁾ Permissible axial displacement from the normal position of one bearing ring in relation to the other

Single row cylindrical roller bearings

d 90 – 95 mm

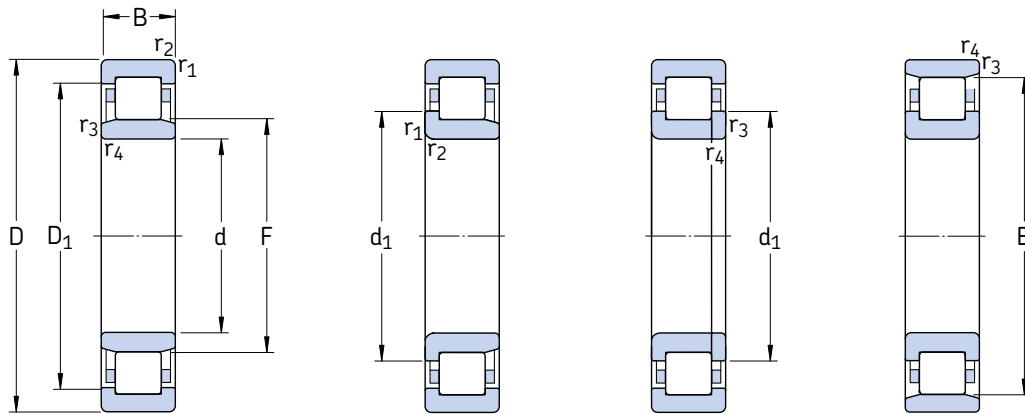

NU

NJ

NUP

N

Principal dimensions			Basic load ratings dynamic static		Fatigue load limit P_u	Speed ratings Refer- ence speed Limiting speed		Mass Bearing with standard cage	Designations Bearing with standard cage	Alternative standard cage designs ¹⁾	
d	D	B	C	C_0				kg	–		
mm			kN		kN	r/min		kg	–		
90 cont.	190	43	365	360	43	3 800	4 500	5,25	* NU 318 ECP	J, M, ML	
	190	43	365	360	43	3 800	4 500	5,40	* NJ 318 ECP	J, M, ML	
	190	43	365	360	43	3 800	4 500	5,65	* NUP 318 ECJ	M, ML	
	190	43	365	360	43	3 800	4 500	5,30	* N 318 ECP	M	
	190	64	500	540	65,5	3 800	4 500	8,00	* NU 2318 ECP	J, ML	
	190	64	500	540	65,5	3 800	4 500	8,15	* NJ 2318 ECP	J, ML, M	
	190	64	500	540	65,5	3 800	4 500	8,30	* NUP 2318 ECP	ML	
	225	54	380	415	48	3 400	4 000	11,5	NU 418	–	
	95	145	24	84,2	110	13,2	5 300	8 000	1,45	NU 1019 ML	–
		170	32	255	265	32,5	4 300	4 800	2,85	* NU 219 ECP	J, M, ML
		170	32	255	265	32,5	4 300	4 800	2,90	* NJ 219 ECP	J, M, ML
		170	32	255	265	32,5	4 300	4 800	3,00	* NUP 219 ECP	ML
170		32	255	265	32,5	4 300	4 800	2,85	* N 219 ECP	–	
170		43	325	375	45,5	4 300	4 800	3,80	* NU 2219 ECP	J, M	
170		43	325	375	45,5	4 300	4 800	3,95	* NJ 2219 ECP	J, M	
170		43	325	375	45,5	4 300	4 800	4,10	* NUP 2219 ECP	–	
200		45	390	390	46,5	3 600	4 300	6,20	* NU 319 ECP	J, M, ML	
200		45	390	390	46,5	3 600	4 300	6,25	* NJ 319 ECP	J, M, ML	
200		45	390	390	46,5	3 600	4 300	6,30	* NUP 319 ECP	M, ML	
200		45	390	390	46,5	3 600	4 300	6,20	* N 319 ECP	M	
200		67	530	585	69,5	3 600	4 300	9,35	* NU 2319 ECP	J, ML	
200		67	530	585	69,5	3 600	4 300	9,55	* NJ 2319 ECP	J, ML	
200		67	530	585	69,5	3 600	4 300	9,75	* NUP 2319 ECP	J, ML	
240		55	413	455	52	3 200	3 600	13,5	NU 419 M	–	

* SKF Explorer bearing

¹⁾ When ordering bearings with an alternative standard cage the suffix of the standard cage has to be replaced by the suffix of the cage in question, e.g. NU 318 ECP becomes NU 318 ECML (for speed ratings → page 517)

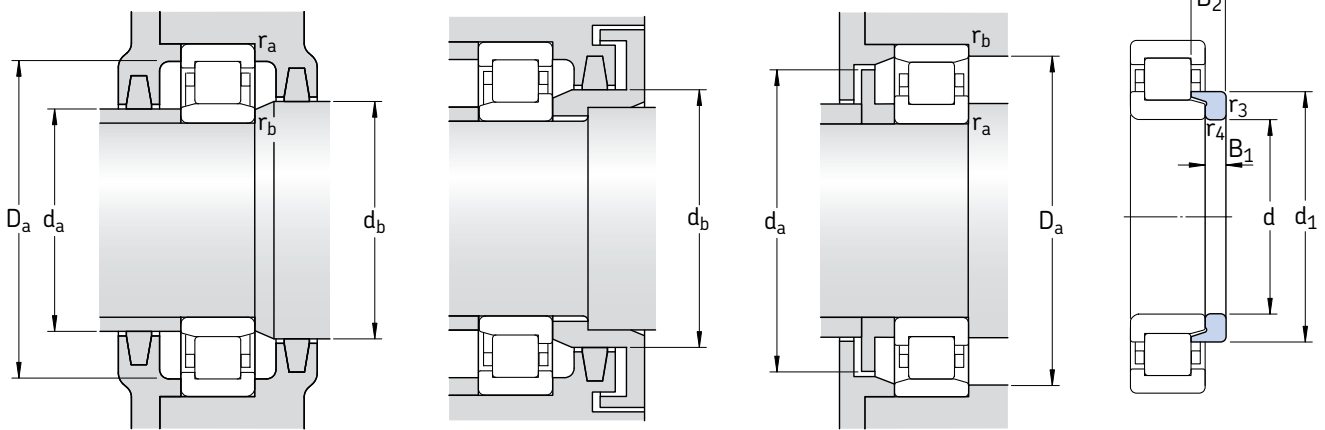

Angle ring

Dimensions							Abutment and fillet dimensions						Calculation factor k_r	Angle ring Designation	Mass	Dimensions		
d	d ₁	D ₁	F, E	r _{1,2} min	r _{3,4} min	s ¹⁾	d _a min	d _a max	d _b , D _a min	D _a max	r _a max	r _b max				B ₁	B ₂	
mm							mm						-	-	kg	mm		
90 cont.	124	162	113,5	3	3	2,5	104	110	116	176	2,5	2,5	0,15	HJ 318 EC	0,60	12	18,5	
	124	162	113,5	3	3	2,5	104	110	127	176	2,5	2,5	0,15	HJ 318 EC	0,60	12	18,5	
	124	162	113,5	3	3	-	104	-	127	176	2,5	2,5	0,15	-	-	-	-	
	124	-	169,5	3	3	2,5	104	166	173	176	2,5	2,5	0,15	-	-	-	-	
	124	162	113,5	3	3	6	104	110	116	176	2,5	2,5	0,25	HJ 2318 EC	0,66	12	22	
	124	162	113,5	3	3	6	104	110	127	176	2,5	2,5	0,25	HJ 2318 EC	0,66	12	22	
	124	162	113,5	3	3	-	104	110	127	176	2,5	2,5	0,25	-	-	-	-	
	-	176	123,5	4	4	4,9	106	120	126	209	3	3	0,15	-	-	-	-	
	95	-	127	108	1,5	1,1	3,5	101	106	111	138	1,5	1	0,1	-	-	-	-
	120	149	112,5	2,1	2,1	1,7	107	110	115	158	2	2	0,15	HJ 219 EC	0,33	9	14	
	120	149	112,5	2,1	2,1	1,7	107	110	123	158	2	2	0,15	HJ 219 EC	0,33	9	14	
	120	149	112,5	2,1	2,1	-	107	-	123	158	2	2	0,15	-	-	-	-	
120	-	154,5	2,1	2,1	1,7	107	152	157	158	2	2	0,15	-	-	-	-		
-	149	112,5	2,1	2,1	3	107	110	115	158	2	2	0,2	-	-	-	-		
120	149	112,5	2,1	2,1	3	107	110	123	158	2	2	0,2	-	-	-	-		
120	149	112,5	2,1	2,1	-	107	-	123	158	2	2	0,2	-	-	-	-		
132	170	121,5	3	3	2,9	109	118	124	186	2,5	2,5	0,15	HJ 319 EC	0,76	13	20,5		
132	170	121,5	3	3	2,9	109	118	135	186	2,5	2,5	0,15	HJ 319 EC	0,76	13	20,5		
132	170	121,5	3	3	-	109	-	135	186	2,5	2,5	0,15	-	-	-	-		
132	-	177,5	3	3	2,9	109	174	181	186	2,5	2,5	0,15	-	-	-	-		
132	170	121,5	3	3	6,9	109	118	124	186	2,5	2,5	0,25	HJ 2319 EC	0,81	13	24,5		
132	170	121,5	3	3	6,9	109	118	135	186	2,5	2,5	0,25	HJ 2319 EC	0,81	13	24,5		
132	170	121,5	3	3	-	109	-	135	186	2,5	2,5	0,25	-	-	-	-		
-	186	133,5	4	4	5	115	130	136	220	3	3	0,15	-	-	-	-		

¹⁾ Permissible axial displacement from the normal position of one bearing ring in relation to the other

Single row cylindrical roller bearings

d 100 – 105 mm

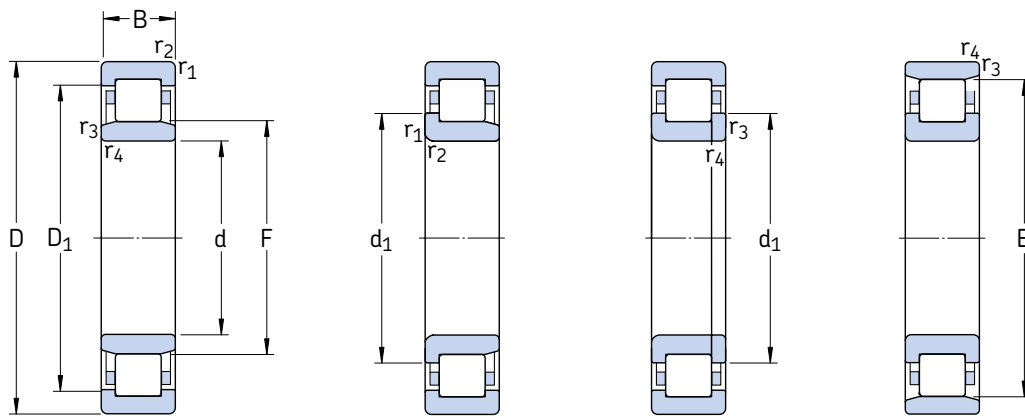

NU

NJ

NUP

N

Principal dimensions			Basic load ratings dynamic static		Fatigue load limit P_u	Speed ratings Refer- ence speed Limiting speed		Mass Bearing with standard cage	Designations Bearing with standard cage cage	Alternative standard cage designs ¹⁾
d	D	B	C	C_0				kg	–	
mm			kN		kN	r/min				
100	150	24	85,8	114	13,7	5 000	7 500	1,45	NU 1020 ML	M
	180	34	285	305	36,5	4 000	4 500	3,40	* NU 220 ECP	J, M, ML
	180	34	285	305	36,5	4 000	4 500	3,50	* NJ 220 ECP	J, M, ML
	180	34	285	305	36,5	4 000	4 500	3,60	* NUP 220 ECP	ML
	180	34	285	305	36,5	4 000	4 500	3,45	* N 220 ECP	–
	180	46	380	450	54	4 000	4 500	4,75	* NU 2220 ECP	J, ML
	180	46	380	450	54	4 000	4 500	4,80	* NJ 2220 ECP	J, ML
	180	46	380	450	54	4 000	4 500	4,90	* NUP 2220 ECP	ML
	215	47	450	440	51	3 200	3 800	7,45	* NU 320 ECP	J, M, ML
	215	47	450	440	51	3 200	3 800	7,65	* NJ 320 ECP	J, M, ML
	215	47	450	440	51	3 200	3 800	7,85	* NUP 320 ECJ	ML
	215	47	450	440	51	3 200	3 800	7,50	* N 320 ECP	M
	215	73	670	735	85	3 200	3 800	12,0	* NU 2320 ECP	J, ML
	215	73	670	735	85	3 200	3 800	12,2	* NJ 2320 ECP	J, ML
	215	73	670	735	85	3 200	3 800	12,5	* NUP 2320 ECP	J, ML
	250	58	429	475	53	3 000	3 600	14,0	NU 420 M	–
105	160	26	101	137	16	4 800	7 500	1,90	NU 1021 ML	M
	190	36	300	315	36,5	3 800	4 300	4,00	* NU 221 ECP	J, ML
	190	36	300	315	36,5	3 800	4 300	4,10	* NJ 221 ECP	ML
	190	36	300	315	36,5	3 800	4 300	4,20	* NUP 221 ECP	ML
	190	36	300	315	36,5	3 800	4 300	3,95	* N 221 ECP	–
	225	49	500	500	57	3 200	3 800	8,55	* NU 321 ECP	J, ML
	225	49	500	500	57	3 200	3 800	8,75	* NJ 321 ECJ	ML
	225	49	500	500	57	3 200	3 800	8,60	* N 321 ECP	–
	260	60	501	570	64	2 800	3 400	19,0	NU 421 M	–

* SKF Explorer bearing

¹⁾ When ordering bearings with an alternative standard cage the suffix of the standard cage has to be replaced by the suffix of the cage in question, e.g. NU 220 ECP becomes NU 220 ECML (for speed ratings → page 517)

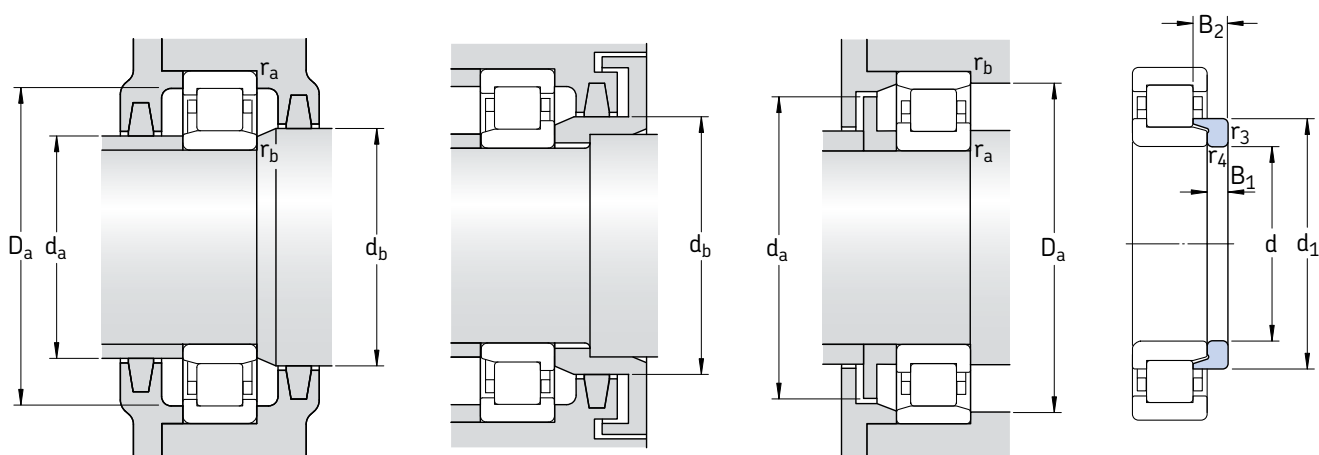

Angle ring

Dimensions							Abutment and fillet dimensions						Calculation factor	Angle ring	Mass	Dimensions	
d	d ₁	D ₁	F, E	r _{1,2}	r _{3,4}	s ¹⁾	d _a	d _a	d _b , D _a	D _a	r _a	r _b	k _r	Designation	kg	B ₁	B ₂
mm							mm						–	–	kg	mm	
100	–	132	113	1,5	1,1	3,5	106	111	116	143	1,5	1	0,1	–			
	127	157	119	2,1	2,1	1,7	112	116	122	168	2	2	0,15	HJ 220 EC	0,42	10	15
	127	157	119	2,1	2,1	1,7	112	116	130	168	2	2	0,15	HJ 220 EC	0,42	10	15
	127	157	119	2,1	2,1	–	112	–	130	168	2	2	0,15	–			
	127	–	163	2,1	2,1	1,7	112	160	166	168	2	2	0,15	–			
	127	157	119	2,1	2,1	2,5	112	116	122	168	2	2	0,2	HJ 2220 EC	0,43	10	16
	127	157	119	2,1	2,1	2,5	112	116	130	168	2	2	0,2	HJ 2220 EC	0,43	10	16
	127	157	119	2,1	2,1	–	112	–	130	168	2	2	0,2	–			
	139	182	127,5	3	3	2,9	114	124	130	201	2,5	2,5	0,15	HJ 320 EC	0,87	13	20,5
	139	182	127,5	3	3	2,9	114	124	142	201	2,5	2,5	0,15	HJ 320 EC	0,87	13	20,5
	139	182	127,5	3	3	–	114	–	142	201	2,5	2,5	0,15	–			
	139	–	191,5	3	3	2,9	114	188	195	201	2,5	2,5	0,15	–			
	139	182	127,5	3	3	5,9	114	124	130	201	2,5	2,5	0,25	HJ 2320 EC	0,93	13	23,5
	139	182	127,5	3	3	5,9	114	124	142	201	2,5	2,5	0,25	HJ 2320 EC	0,93	13	23,5
	139	182	127,5	3	3	–	114	–	142	201	2,5	2,5	0,25	–			
	153	195	139	4	4	4,9	120	135	142	230	3	3	0,15	HJ 420	1,50	16	27
105	–	140	119,5	2	1,1	3,8	111	117	122	151	2	1	0,1	–			
	134	164	125	2,1	2,1	2	117	122	128	178	2	2	0,15	HJ 221 EC	0,50	10	17,5
	134	164	125	2,1	2,1	2	117	122	137	178	2	2	0,15	HJ 221 EC	0,50	10	17,5
	134	164	125	2,1	2,1	–	117	–	137	178	2	2	0,15	–			
	134	–	173	2,1	2,1	2	117	170	176	178	2	2	0,15	–			
	–	190	133	3	3	3,4	119	130	136	211	2,5	2,5	0,15	–			
	145	190	133	3	3	3,4	119	130	148	211	2,5	2,5	0,15	–			
	145	–	201	3	3	3,4	119	198	203	211	2,5	2,5	0,15	–			
	–	203	144,5	4	4	4,9	125	140	147	240	3	3	0,15	–			

¹⁾ Permissible axial displacement from the normal position of one bearing ring in relation to the other

Single row cylindrical roller bearings

d 110 – 120 mm

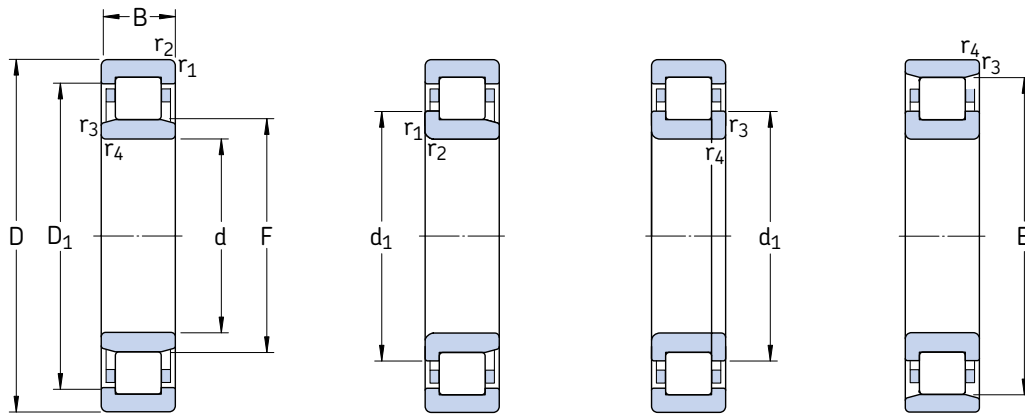

NU

NJ

NUP

N

Principal dimensions			Basic load ratings dynamic static		Fatigue load limit P_u	Speed ratings Reference speed Limiting speed		Mass Bearing with standard cage	Designations Bearing with standard cage	Alternative standard cage designs	
d	D	B	C	C_0							
mm			kN		kN	r/min		kg	–		
110	170	28	128	166	19,3	4 500	7 000	2,35	NU 1022 ML	M	
	200	38	335	365	42,5	3 600	4 000	4,80	* NU 222 ECP	J, M, ML	
	200	38	335	365	42,5	3 600	4 000	4,90	* NJ 222 ECP	J, M, ML	
	200	38	335	365	42,5	3 600	4 000	5,00	* NUP 222 ECP	ML	
	200	38	335	365	42,5	3 600	4 000	4,80	* N 222 ECP	M	
	200	53	440	520	61	3 600	4 000	6,70	* NU 2222 ECP	J, ML	
	200	53	440	520	61	3 600	4 000	6,75	* NJ 2222 ECP	J, ML	
	200	53	440	520	61	3 600	4 000	6,80	* NUP 2222 ECP	ML	
	240	50	530	540	61	3 000	3 400	10,3	* NU 322 ECP	J, M, ML	
	240	50	530	540	61	3 000	3 400	10,5	* NJ 322 ECP	J, M, ML	
	240	50	530	540	61	3 000	3 400	10,7	* NUP 322 ECP	J, ML	
	240	50	530	540	61	3 000	3 400	10,2	* N 322 ECP	M	
	240	80	780	900	102	3 000	3 400	17,0	* NU 2322 ECP	MA	
	240	80	780	900	102	3 000	3 400	17,2	* NJ 2322 ECP	MA	
	240	80	780	900	102	3 000	3 400	17,4	* NUP 2322 ECP	MA	
	280	65	532	585	64	2 600	3 200	20,0	NU 422	–	
	280	65	532	585	64	2 600	3 200	20,3	NJ 422	–	
	120	180	28	134	183	20,8	4 000	6 300	2,55	NU 1024 ML	M
		215	40	390	430	49	3 400	3 600	5,75	* NU 224 ECP	J, M, ML
215		40	390	430	49	3 400	3 600	5,85	* NJ 224 ECP	J, M, ML	
215		40	390	430	49	3 400	3 600	6,00	* NUP 224 ECJ	ML	
215		40	390	430	49	3 400	3 600	5,75	* N 224 ECP	M	
215		58	520	630	72	3 400	3 600	8,30	* NU 2224 ECP	J, M, ML	
215		58	520	630	72	3 400	3 600	8,50	* NJ 2224 ECP	J, M, ML	
215		58	520	630	72	3 400	3 600	8,70	* NUP 2224 ECP	ML	
260		55	610	620	69,5	2 800	3 200	13,0	* NU 324 ECP	J, M, ML	
260		55	610	620	69,5	2 800	3 200	13,3	* NJ 324 ECP	J, M, ML	
260		55	610	620	69,5	2 800	3 200	13,7	* NUP 324 ECP	ML	
260		55	610	620	69,5	2 800	3 200	13,0	* N 324 ECP	M	

* SKF Explorer bearing

¹⁾ When ordering bearings with an alternative standard cage the suffix of the standard cage has to be replaced by the suffix of the cage in question, e.g. NU 222 ECP becomes NU 222 ECML (for speed ratings → page 517)

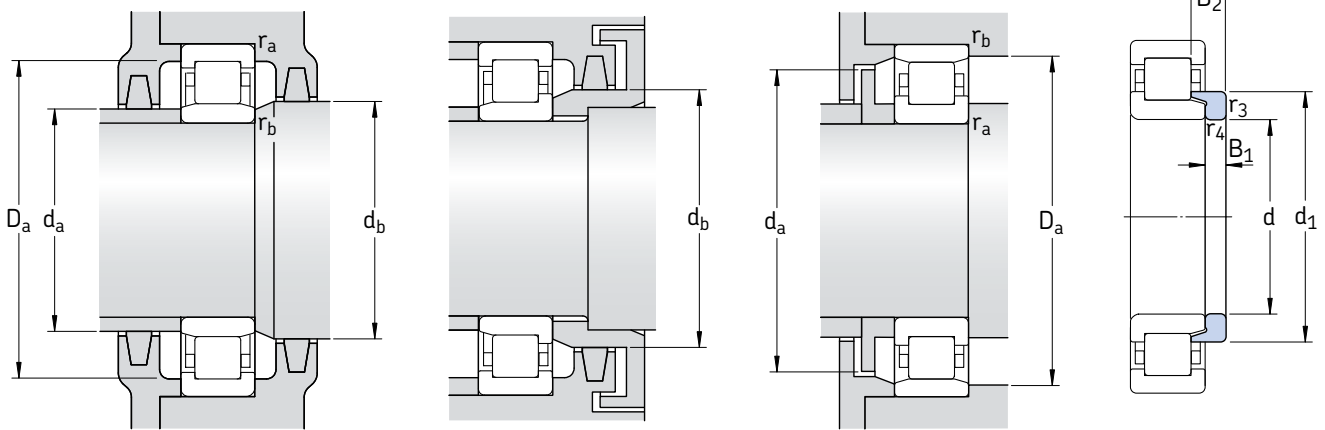

Angle ring

Dimensions							Abutment and fillet dimensions						Calculation factor	Angle ring	Mass	Dimensions	
d	d ₁	D ₁	F, E	r _{1,2}	r _{3,4}	s ¹⁾	d _a	d _a	d _b , D _a	D _a	r _a	r _b	k _r	Designation	kg	B ₁	B ₂
							mm						-	-		mm	
110	-	149	125	2	1,1	3,8	116	123	128	161	2	1	0,1	-			
	141	174	132,5	2,1	2,1	2,1	122	130	135	188	2	2	0,15	HJ 222 EC	0,60	11	17
	141	174	132,5	2,1	2,1	2,1	122	130	145	188	2	2	0,15	HJ 222 EC	0,60	11	17
	141	174	132,5	2,1	2,1	-	122	-	145	188	2	2	0,15	-			
	141	-	180,5	2,1	2,1	2,1	122	177	183	188	2	2	0,15	-			
	-	174	132,5	2,1	2,1	3,7	122	129	135	188	2	2	0,2	-			
	141	174	132,5	2,1	2,1	3,7	122	129	145	188	2	2	0,2	-			
	141	174	132,5	2,1	2,1	-	122	-	145	188	2	2	0,2	-			
	155	201	143	3	3	3	124	139	146	226	2,5	2,5	0,15	HJ 322 EC	1,20	14	22
	155	201	143	3	3	3	124	139	159	226	2,5	2,5	0,15	HJ 322 EC	1,20	14	22
	155	201	143	3	3	-	124	-	159	226	2,5	2,5	0,15	-			
	155	-	211	3	3	3	124	208	215	226	2,5	2,5	0,15	-			
	155	201	143	3	3	7,5	124	139	146	226	2,5	2,5	0,25	HJ 2322 EC	1,25	14	26,5
	155	201	143	3	3	7,5	124	139	159	226	2,5	2,5	0,25	HJ 2322 EC	1,25	14	26,5
	155	201	143	3	3	-	124	-	159	226	2,5	2,5	0,25	-			
	171	217	155	4	4	4,8	130	150	158	260	3	3	0,15	HJ 422	2,10	17	29,5
	171	217	155	4	4	4,8	130	150	174	260	3	3	0,15	HJ 422	2,10	17	29,5
120	-	159	135	2	1,1	3,8	126	133	138	171	2	1	0,1	-			
	153	188	143,5	2,1	2,1	1,9	132	140	146	203	2	2	0,15	HJ 224 EC	0,69	11	17
	153	188	143,5	2,1	2,1	1,9	132	140	156	203	2	2	0,15	HJ 224 EC	0,69	11	17
	153	188	143,5	2,1	2,1	-	132	-	156	203	2	2	0,15	-			
	153	-	195,5	2,1	2,1	1,9	132	192	199	203	2	2	0,15	-			
	153	188	143,5	2,1	2,1	3,8	132	140	146	203	2	2	0,2	HJ 2224 EC	0,74	11	20
	153	188	143,5	2,1	2,1	3,8	132	140	156	203	2	2	0,2	HJ 2224 EC	0,74	11	20
	153	188	143,5	2,1	2,1	-	132	-	156	203	2	2	0,2	-			
	168	219	154	3	3	3,7	134	150	157	246	2,5	2,5	0,15	HJ 324 EC	1,40	14	22,5
	168	219	154	3	3	3,7	134	150	171	246	2,5	2,5	0,15	HJ 324 EC	1,40	14	22,5
	168	219	154	3	3	-	134	-	171	246	2,5	2,5	0,15	-			
	168	-	230	3	3	3,7	134	226	234	246	2,5	2,5	0,15	-			

¹⁾ Permissible axial displacement from the normal position of one bearing ring in relation to the other

Single row cylindrical roller bearings

d 120 – 140 mm

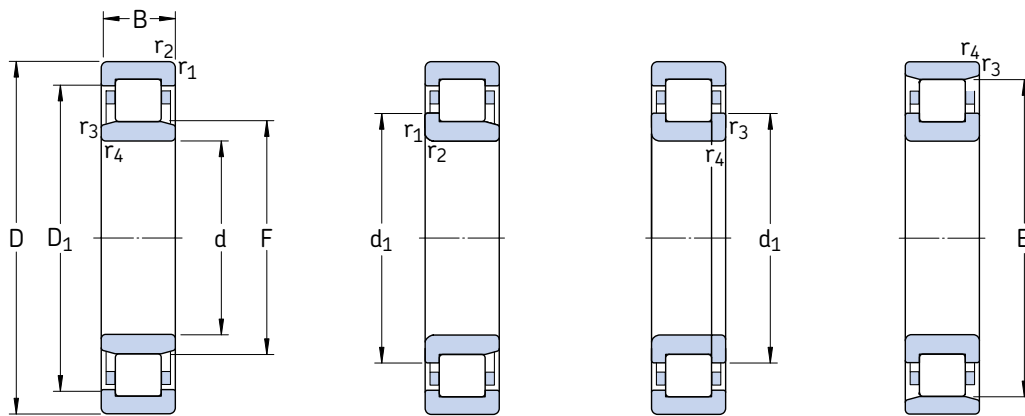

NU

NJ

NUP

N

Principal dimensions			Basic load ratings dynamic static		Fatigue load limit P_u	Speed ratings Refer- ence speed Limiting speed		Mass Bearing with standard cage	Designations Bearing with standard cage	Alternative standard cage designs ¹⁾
d	D	B	C	C_0						
mm			kN		kN	r/min		kg	–	
120 cont.	260	86	915	1 040	116	2 800	4 300	23,3	* NU 2324 ECMA	–
	260	86	915	1 040	116	2 800	4 300	23,6	* NJ 2324 ECMA	M
	260	86	915	1 040	116	2 800	4 300	24,0	* NUP 2324 ECMA	–
	310	72	644	735	78	2 400	2 800	28,0	NU 424	–
130	200	33	165	224	25	3 800	5 600	3,85	NU 1026 ML	M
	230	40	415	455	51	3 200	3 400	6,45	* NU 226 ECP	J, M, ML
	230	40	415	455	51	3 200	3 400	6,60	* NJ 226 ECP	J, M, ML
	230	40	415	455	51	3 200	3 400	6,75	* NUP 226 ECP	J, ML
	230	40	415	455	51	3 200	3 400	6,30	* N 226 ECP	–
	230	64	610	735	83	3 200	3 400	10,3	* NU 2226 ECP	ML
	230	64	610	735	83	3 200	3 400	10,6	* NJ 2226 ECP	ML
	230	64	610	735	83	3 200	3 400	11,0	* NUP 2226 ECP	ML
	280	58	720	750	81,5	2 400	3 000	16,1	* NU 326 ECP	J, M, ML
	280	58	720	750	81,5	2 400	3 000	16,5	* NJ 326 ECP	J, M, ML
	280	58	720	750	81,5	2 400	3 000	17,0	* NUP 326 ECP	ML
	280	58	720	750	81,5	2 400	3 000	16,0	* N 326 ECP	M
	280	93	1 060	1 250	137	2 400	3 800	30,0	* NU 2326 ECMA	–
	280	93	1 060	1 250	137	2 400	3 800	30,5	* NJ 2326 ECMA	–
	280	93	1 060	1 250	137	2 400	3 800	31,0	* NUP 2326 ECMA	–
140	210	33	172	245	27	3 600	5 300	4,05	NU 1028 ML	M
	250	42	450	510	57	2 800	3 200	9,00	* NU 228 ECM	J, ML
	250	42	450	510	57	2 800	3 200	9,20	* NJ 228 ECM	J, ML
	250	42	450	510	57	2 800	3 200	9,40	* NUP 228 ECM	ML
	250	68	655	830	93	2 800	4 800	15,0	* NU 2228 ECML	–
	250	68	655	830	93	2 800	4 800	15,3	* NJ 2228 ECML	–
	250	68	655	830	93	2 800	4 800	15,6	* NUP 2228 ECML	–
	300	62	780	830	88	2 400	2 800	22,0	* NU 328 ECM	J, ML
	300	62	780	830	88	2 400	2 800	22,5	* NJ 328 ECM	J, ML
	300	62	780	830	88	2 400	2 800	23,0	* NUP 328 ECM	ML

* SKF Explorer bearing

¹⁾ When ordering bearings with an alternative standard cage the suffix of the standard cage has to be replaced by the suffix of the cage in question, e.g. NU 226 ECP becomes NU 226 ECML (for speed ratings → page 517)

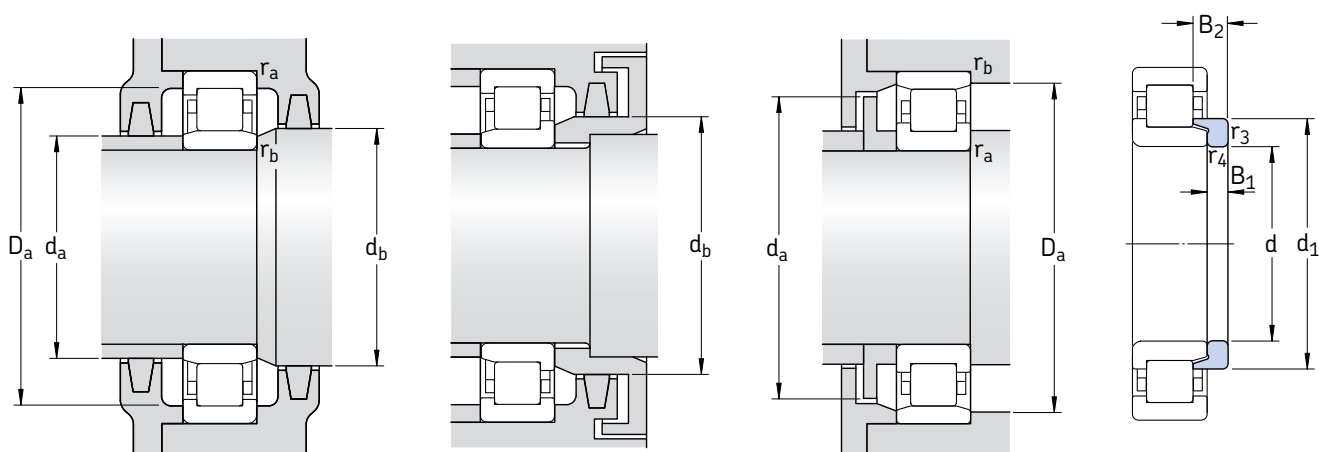

Angle ring

Dimensions							Abutment and fillet dimensions						Calculation factor k_r	Angle ring Designation	Mass	Dimensions	
d	d_1	D_1	F, E	$r_{1,2}$	$r_{3,4}$	$s^1)$	d_a	d_a	d_b, D_a	D_a	r_a	r_b				B_1	B_2
mm							mm						-	-	kg	mm	
120 cont.	168	219	154	3	3	7,2	134	150	157	246	2,5	2,5	0,25	HJ 2324 EC	1,45	14	26
	168	219	154	3	3	7,2	134	150	171	246	2,5	2,5	0,25	HJ 2324 EC	1,45	14	26
	168	219	154	3	3	-	134	-	171	246	2,5	2,5	0,25	-	-	-	-
	188	240	170	5	5	6,3	144	165	173	286	4	4	0,15	HJ 424	2,60	17	30,5
130	-	175	148	2	1,1	4,7	136	145	151	191	2	1	0,1	-	-	-	-
	164	202	153,5	3	3	2,1	144	150	156	216	2,5	2,5	0,15	HJ 226 EC	0,75	11	17
	164	202	153,5	3	3	2,1	144	150	167	216	2,5	2,5	0,15	HJ 226 EC	0,75	11	17
	164	202	153,5	3	3	-	144	-	167	216	2,5	2,5	0,15	-	-	-	-
	164	-	209,5	3	3	2,1	144	206	213	216	2,5	2,5	0,15	-	-	-	-
	164	202	153,5	3	3	4,3	144	149	156	216	2,5	2,5	0,2	HJ 2226 EC	0,83	11	21
	164	202	153,5	3	3	4,3	144	149	167	216	2,5	2,5	0,2	HJ 2226 EC	0,83	11	21
	164	202	153,5	3	3	-	144	-	167	216	2,5	2,5	0,2	-	-	-	-
	181	236	167	4	4	3,7	147	163	170	263	3	3	0,15	HJ 326 EC	1,60	14	23
	181	236	167	4	4	3,7	147	163	185	263	3	3	0,15	HJ 326 EC	1,60	14	23
	181	236	167	4	4	-	147	-	185	263	3	3	0,15	-	-	-	-
	181	-	247	4	4	3,7	147	243	251	263	3	3	0,15	-	-	-	-
	181	236	167	4	4	8,7	147	163	170	263	3	3	0,25	HJ 2326 EC	1,70	14	28
	181	236	167	4	4	8,7	147	163	185	263	3	3	0,25	HJ 2326 EC	1,70	14	28
	181	236	167	4	4	-	147	-	185	263	3	3	0,25	-	-	-	-
140	-	185	158	2	1,1	4,4	146	155	161	201	2	1	0,1	-	-	-	-
	179	217	169	3	3	2,5	154	166	172	236	2,5	2,5	0,15	HJ 228 EC	1,00	10	18
	179	217	169	3	3	2,5	154	166	183	236	2,5	2,5	0,15	HJ 228 EC	1,00	10	18
	179	217	169	3	3	-	154	-	183	236	2,5	2,5	0,15	-	-	-	-
	179	217	169	3	3	4,4	154	164	172	236	2,5	2,5	0,2	HJ 2228 EC	1,05	11	23
	179	217	169	3	3	4,4	154	164	183	236	2,5	2,5	0,2	HJ 2228 EC	1,05	11	23
	179	217	169	3	3	-	154	-	183	236	2,5	2,5	0,2	-	-	-	-
	195	252	180	4	4	3,7	157	176	183	283	3	3	0,15	HJ 328 EC	2,00	15	25
	195	252	180	4	4	3,7	157	176	199	283	3	3	0,15	HJ 328 EC	2,00	15	25
	195	252	180	4	4	-	157	-	199	283	3	3	0,15	-	-	-	-

¹⁾ Permissible axial displacement from the normal position of one bearing ring in relation to the other

Single row cylindrical roller bearings

d 140 – 160 mm

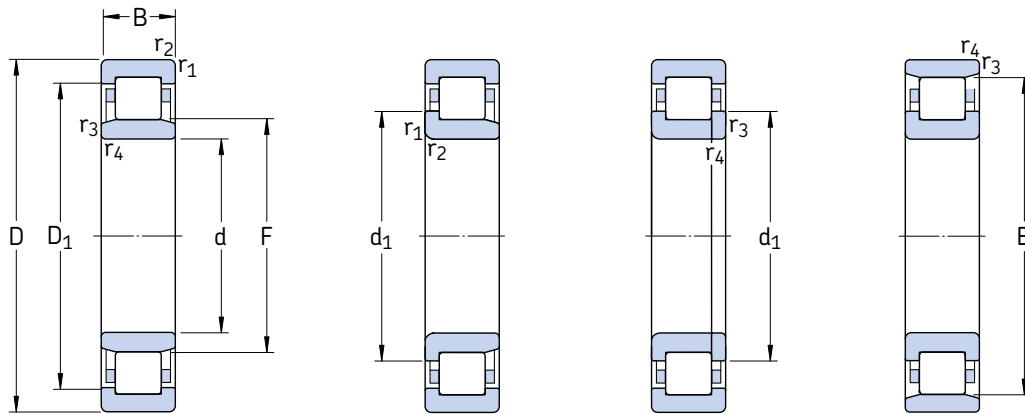

NU

NJ

NUP

N

Principal dimensions			Basic load ratings dynamic static		Fatigue load limit P_u	Speed ratings Refer- ence speed Limiting speed		Mass Bearing with standard cage	Designations Bearing with standard cage	Alternative standard cage designs ¹⁾
d	D	B	C	C_0				kg	–	
mm			kN		kN	r/min		kg	–	
140 cont.	300	102	1 200	1 430	150	2 400	3 600	37,0	* NU 2328 ECMA	–
	300	102	1 200	1 430	150	2 400	3 600	37,5	* NJ 2328 ECMA	–
	300	102	1 200	1 430	150	2 400	3 600	38,0	* NUP 2328 ECMA	–
150	225	35	194	275	30	3 200	5 000	4,90	NU 1030 ML	M
	270	45	510	600	64	2 600	2 800	11,8	* NU 230 ECM	J, ML
	270	45	510	600	64	2 600	2 800	12,0	* NJ 230 ECM	J, ML
	270	45	510	600	64	2 600	2 800	12,2	* NUP 230 ECM	ML
	270	73	735	930	100	2 600	2 800	18,5	* NU 2230 ECM	–
	270	73	735	930	100	2 600	2 800	19,0	* NJ 2230 ECM	–
	320	65	900	965	100	2 200	2 600	26,3	* NU 330 ECM	MA
	320	65	900	965	100	2 200	2 600	27,0	* NJ 330 ECM	MA
	320	108	1 370	1 630	166	2 200	3 400	45,5	* NU 2330 ECMA	–
	320	108	1 370	1 630	166	2 200	3 400	46,0	* NJ 2330 ECMA	–
	320	108	1 370	1 630	166	2 200	3 400	46,5	* NUP 2330 ECMA	–
	160	240	38	229	325	35,5	3 000	4 800	5,95	NU 1032 ML
290		48	585	680	72	2 400	2 600	14,1	* NU 232 ECM	ML
290		48	585	680	72	2 400	2 600	14,4	* NJ 232 ECM	ML
290		48	585	680	72	2 400	2 600	14,8	* NUP 232 ECM	ML
290		48	585	680	72	2 400	2 600	14,0	* N 232 ECM	–
290		80	930	1 200	129	2 400	3 600	24,3	* NU 2232 ECMA	–
290		80	930	1 200	129	2 400	3 600	24,8	* NJ 2232 ECMA	–
340		68	1 000	1 080	112	2 000	2 400	32,0	* NU 332 ECM	MA
340		68	1 000	1 080	112	2 000	2 400	32,5	* NJ 332 ECM	MA
340		114	1 250	1 730	173	1 800	2 800	53,0	NU 2332 ECMA	–
340		114	1 250	1 730	173	1 800	2 800	53,5	NJ 2332 ECMA	–

* SKF Explorer bearing

¹⁾ When ordering bearings with an alternative standard cage the suffix of the standard cage has to be replaced by the suffix of the cage in question, e.g. NU 230 ECM becomes NU 230 ECML (for speed ratings → page 517)

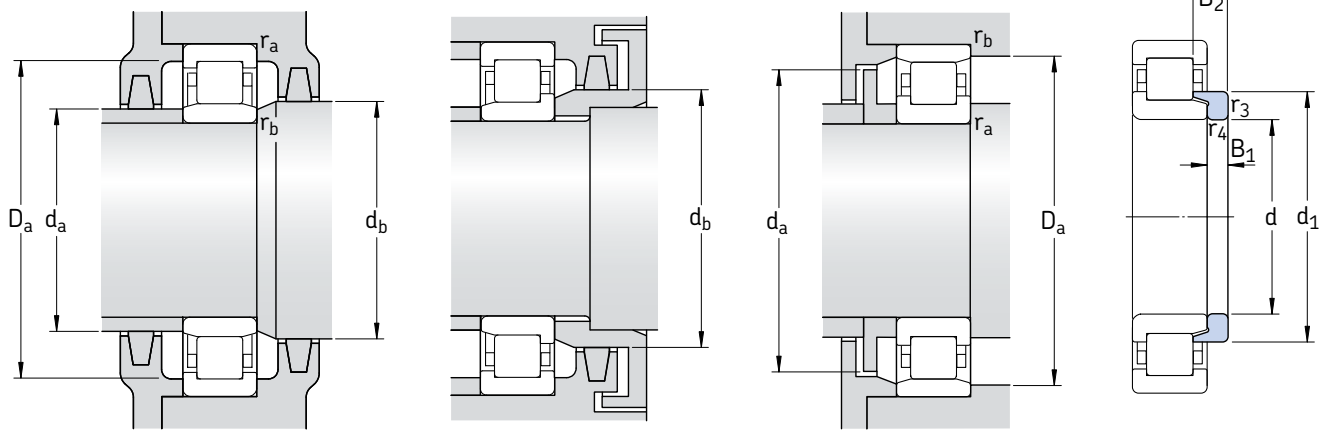

Angle ring

Dimensions							Abutment and fillet dimensions						Calculation factor	Angle ring	Mass	Dimensions	
d	d ₁	D ₁	F, E	r _{1,2}	r _{3,4}	s ¹⁾	d _a min	d _a max	d _b , D _a min	D _a max	r _a max	r _b max	k _r	Designation	kg	B ₁	B ₂
mm							mm						-	-	kg	mm	
140 cont.	195	252	180	4	4	9,7	157	176	183	283	3	3	0,25	HJ 2328 EC	2,15	15	31
	195	252	180	4	4	9,7	157	176	199	283	3	3	0,25	HJ 2328 EC	2,15	15	31
	195	252	180	4	4	-	157	-	199	283	3	3	0,25	-	-	-	-
150	-	198	169,5	2,1	1,5	4,9	157	167	173	215	2	1,5	0,1	-	-	-	-
	193	234	182	3	3	2,5	163	178	185	256	2,5	2,5	0,15	HJ 230 EC	1,25	12	19,5
	193	234	182	3	3	2,5	164	178	197	256	2,5	2,5	0,15	HJ 230 EC	1,25	12	19,5
	193	234	182	3	3	-	164	-	197	256	2,5	2,5	0,15	-	-	-	-
	194	234	182	3	3	4,9	164	179	185	256	2,5	2,5	0,2	HJ 2230 EC	1,35	12	24,5
	194	234	182	3	3	4,9	164	179	197	256	2,5	2,5	0,2	HJ 2230 EC	1,35	12	24,5
	209	270	193	4	4	4	167	189	196	303	3	3	0,15	HJ 330 EC	2,35	15	25
	209	270	193	4	4	4	167	189	213	303	3	3	0,15	HJ 330 EC	2,35	15	25
	209	270	193	4	4	10,5	167	189	196	303	3	3	0,25	-	-	-	-
	209	270	193	4	4	10,5	167	189	213	303	3	3	0,25	-	-	-	-
	209	270	193	4	4	-	167	-	213	303	3	3	0,25	-	-	-	-
	160	188	211	180	2,1	1,5	5,2	167	177	183	230	2	1,5	0,1	HJ 1032	0,65	10
206		250	195	3	3	2,7	174	191	198	276	2,5	2,5	0,15	HJ 232 EC	1,50	12	20
206		250	195	3	3	2,7	174	191	210	276	2,5	2,5	0,15	HJ 232 EC	1,50	12	20
206		250	195	3	3	-	174	-	210	276	2,5	2,5	0,15	-	-	-	-
206		-	259	3	3	2,7	174	255	263	276	2,5	2,5	0,15	-	-	-	-
205		252	193	3	3	4,5	174	188	196	276	2,5	2,5	0,2	HJ 2232 EC	1,55	12	24,5
205		252	193	3	3	4,5	174	188	209	276	2,5	2,5	0,2	HJ 2232 EC	1,55	12	24,5
221		286	204	4	4	4	177	200	207	323	3	3	0,15	HJ 332 EC	2,55	15	25
221		286	204	4	4	4	177	200	225	323	3	3	0,15	HJ 332 EC	2,55	15	25
-		286	204	4	4	11	177	200	207	323	3	3	0,25	-	-	-	-
221		286	204	4	4	11	177	200	225	323	3	3	0,25	-	-	-	-

¹⁾ Permissible axial displacement from the normal position of one bearing ring in relation to the other

Single row cylindrical roller bearings

d 170 – 190 mm

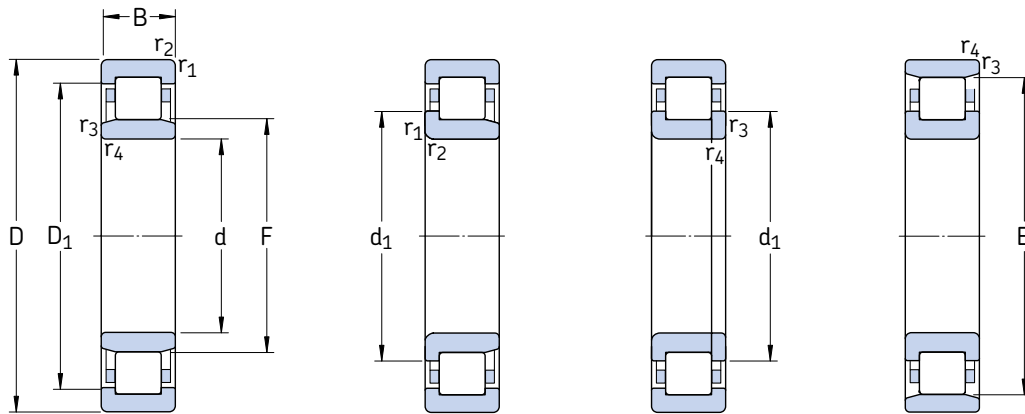

NU

NJ

NUP

N

Principal dimensions			Basic load ratings dynamic static		Fatigue load limit P_u	Speed ratings Refer- ence speed Limiting speed		Mass Bearing with standard cage	Designations Bearing with standard cage	Alternative standard cage designs ¹⁾
d	D	B	C	C_0						
mm			kN		kN	r/min		kg	–	
170	260	42	275	400	41,5	2 800	4 300	8,00	NU 1034 ML	M
	310	52	695	815	85	2 200	2 400	18,2	* NU 234 ECM	MA
	310	52	695	815	85	2 200	2 400	18,6	* NJ 234 ECM	MA
	310	52	695	815	85	2 200	2 400	19,0	* NUP 234 ECM	MA
	310	86	1 060	1 340	140	2 200	3 200	30,0	* NU 2234 ECMA	–
	360	72	952	1 180	116	1 700	2 200	37,5	NU 334 ECM	MA
	360	72	952	1 180	116	1 700	2 200	38,5	N 334 ECM	–
	360	120	1 450	2 040	204	1 700	3 000	62,0	NU 2334 ECMA	–
	360	120	1 450	2 040	204	1 700	3 000	63,0	NJ 2334 ECMA	–
	180	280	46	336	475	51	2 600	4 000	10,5	NU 1036 ML
320		52	720	850	88	2 200	3 200	19,0	* NU 236 ECMA	–
320		52	720	850	88	2 200	3 200	19,3	* NJ 236 ECMA	–
320		52	720	850	88	2 200	3 200	19,8	* NUP 236 ECMA	–
320		86	1 100	1 430	146	2 200	3 200	31,5	* NU 2236 ECMA	M
320		86	1 100	1 430	146	2 200	3 200	32,0	* NJ 2236 ECMA	M
380		75	1 020	1 290	125	1 600	2 200	44,0	NU 336 ECM	–
380		126	1 610	2 240	216	1 600	2 800	71,5	NU 2336 ECMA	–
190	290	46	347	500	53	2 600	3 800	11,0	NU 1038 ML	–
	340	55	800	965	98	2 000	3 000	24,0	* NU 238 ECMA	M
	340	55	800	965	98	2 000	3 000	24,5	* NJ 238 ECMA	M
	340	55	800	965	98	2 000	3 000	25,0	* NUP 238 ECMA	M
	340	92	1 220	1 600	160	2 000	3 000	39,0	* NU 2238 ECMA	–
	400	78	1 140	1 500	143	1 500	2 000	50,0	NU 338 ECM	–
	400	132	1 830	2 550	236	1 500	2 600	82,5	NU 2338 ECMA	–

* SKF Explorer bearing

¹⁾ When ordering bearings with an alternative standard cage the suffix of the standard cage has to be replaced by the suffix of the cage in question, e.g. NU 234 ECM becomes NU 234 ECMA (for speed ratings → page 517)

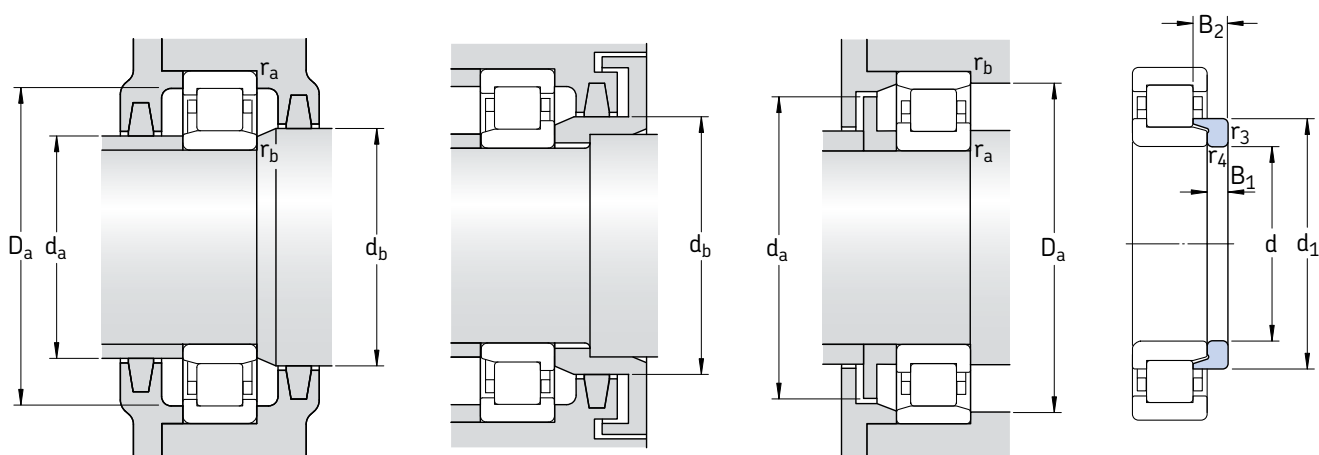

Angle ring

Dimensions							Abutment and fillet dimensions						Calculation factor	Angle ring Designation	Mass	Dimensions	
d	d ₁	D ₁	F, E	r _{1,2}	r _{3,4}	s ¹⁾	d _a	d _a	d _b , D _a	D _a	r _a	r _b	k _r			B ₁	B ₂
mm							mm						-	-	kg	mm	
170	201	227	193	2,1	2,1	5,8	180	190	196	250	2	2	0,1	HJ 1034	0,94	11	21
	220	268	207	4	4	2,9	187	203	210	293	3	3	0,15	HJ 234 EC	1,65	12	20
	220	268	207	4	4	2,9	187	203	224	293	3	3	0,15	HJ 234 EC	1,65	12	20
	220	268	207	4	4	-	187	-	224	293	3	3	0,15	-			
	220	270	205	4	4	4,2	187	200	208	293	3	3	0,2	HJ 2234 EC	1,80	12	24
	-	303	218	4	4	4,6	187	214	221	343	3	3	0,15	-			
	236	-	318	4	4	4,6	187	313	323	343	3	3	0,15	-			
	-	301	216	4	4	10	187	211	220	343	3	3	0,25	-			
	234	301	216	4	4	10	187	211	238	343	3	3	0,25	-			
	-	-	-	-	-	-	-	-	-	-	-	-	-	-			
180	215	244	205	2,1	2,1	6,1	190	202	208	270	2	2	0,1	HJ 1036	1,25	12	22,5
	230	279	217	4	4	2,9	197	213	220	303	3	3	0,15	HJ 236 EC	1,70	12	20
	230	279	217	4	4	2,9	197	213	234	303	3	3	0,15	HJ 236 EC	1,70	12	20
	230	279	217	4	4	-	197	-	234	303	3	3	0,15	-			
	229	280	215	4	4	4,2	197	210	218	303	3	3	0,2	HJ 2236 EC	1,90	12	24
	229	280	215	4	4	4,2	197	210	233	303	3	3	0,2	HJ 2236 EC	1,90	12	24
	-	319	231	4	4	4,2	197	223	235	363	3	3	0,15	-			
	-	320	227	4	4	10,5	197	223	231	363	3	3	0,25	-			
190	225	254	215	2,1	2,1	6,1	200	212	218	280	2	2	0,1	HJ 1038	1,35	12	22,5
	244	295	230	4	4	3	207	226	234	323	3	3	0,15	HJ 238 EC	2,10	13	21,5
	244	295	230	4	4	3	207	226	248	323	3	3	0,15	HJ 238 EC	2,10	13	21,5
	244	295	230	4	4	-	207	-	248	323	3	3	0,15	-			
	-	297	228	4	4	5	207	222	232	323	3	3	0,2	-			
	264	338	245	5	5	4,3	210	240	249	380	4	4	0,15	HJ 338 EC	4,30	18	29
	-	341	240	5	5	9,5	210	235	244	380	4	4	0,25	-			

¹⁾ Permissible axial displacement from the normal position of one bearing ring in relation to the other

Single row cylindrical roller bearings

d 200 – 240 mm

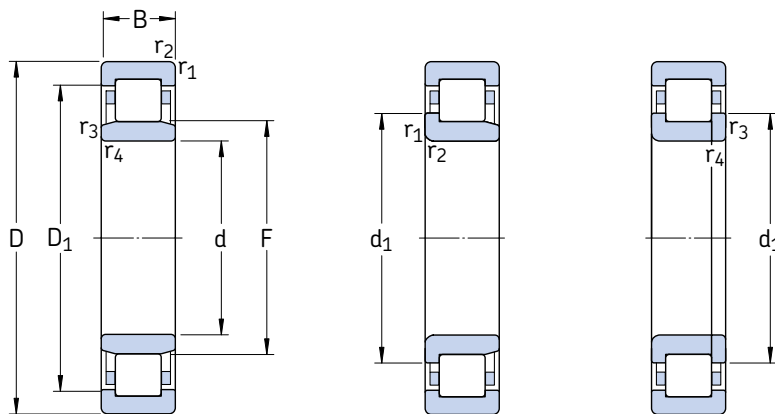

NU

NJ

NUP

Principal dimensions			Basic load ratings dynamic static		Fatigue load limit P_u	Speed ratings Refer- ence speed Limiting speed		Mass Bearing with standard cage	Designations Bearing with standard cage	Alternative standard cage designs ¹⁾	
d	D	B	C	C_0							
mm			kN		kN	r/min		kg	–		
200	310	51	380	570	58,5	2 400	3 000	14,5	NU 1040 MA	M	
	360	58	850	1 020	100	1 900	2 800	28,5	* NU 240 ECMA	M	
	360	58	850	1 020	100	1 900	2 800	29,0	* NJ 240 ECMA	M	
	360	58	850	1 020	100	1 900	2 800	29,5	* NUP 240 ECMA	M	
	360	98	1 370	1 800	180	1 900	2 800	46,0	* NU 2240 ECMA	–	
	420	80	1 230	1 630	150	1 400	2 400	57,5	NU 340 ECMA	–	
	420	138	1 980	2 800	255	1 400	2 400	96,5	NU 2340 ECMA	–	
	420	138	1 980	2 800	255	1 400	2 400	97,0	NJ 2340 ECMA	–	
	220	340	56	495	735	73,5	2 200	2 800	18,5	NU 1044 MA	M
		400	65	1 060	1 290	125	1 600	2 400	38,5	* NU 244 ECMA	M
400		65	1 060	1 290	125	1 600	2 400	39,0	* NJ 244 ECMA	M	
400		65	1 060	1 290	125	1 600	2 400	39,5	* NUP 244 ECMA	M	
400		108	1 570	2 280	212	1 600	2 400	62,5	NU 2244 ECMA	–	
460		88	1 210	1 630	150	1 500	1 700	72,5	NU 344 M	–	
460		88	1 210	1 630	150	1 500	1 700	73,5	NJ 344 M	–	
460		145	2 380	3 450	310	1 300	2 200	120	NU 2344 ECMA	–	
240	360	56	523	800	78	2 000	2 600	20,0	NU 1048 MA	–	
	440	72	952	1 370	129	1 600	2 200	51,5	NU 248 MA	–	
	440	72	952	1 370	129	1 600	2 200	52,5	NJ 248 MA	–	
	440	72	952	1 370	129	1 600	2 200	53,5	NUP 248 MA	–	
	440	120	1 450	2 360	216	1 500	2 200	84,0	NU 2248 MA	–	
	440	120	1 450	2 360	216	1 500	2 200	85,0	NJ 2248 MA	–	
	500	95	1 450	2 000	180	1 300	1 600	94,5	NU 348 M	–	
	500	95	1 450	2 000	180	1 300	2 000	98,5	NJ 348 MA	–	
	500	155	2 600	3 650	320	1 200	2 000	155	NU 2348 ECMA	–	

* SKF Explorer bearing

¹⁾ When ordering bearings with an alternative standard cage the suffix of the standard cage has to be replaced by the suffix of the cage in question, e.g. NU 240 ECMA becomes NU 240 ECM (for speed ratings → page 517)

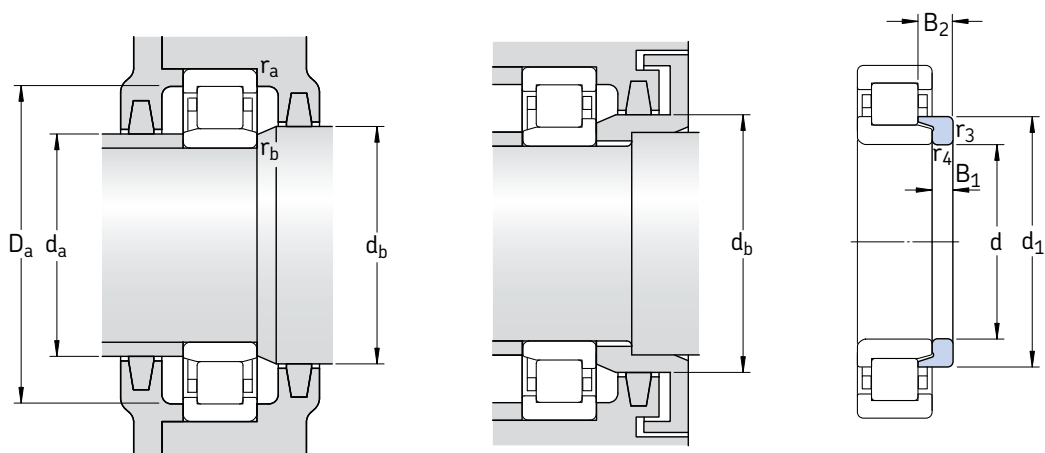

Angle ring

Dimensions							Abutment and fillet dimensions						Calculation factor k_r	Angle ring Designation	Mass	Dimensions		
d	d_1	D_1	F	$r_{1,2}$ min	$r_{3,4}$ min	$s^1)$	d_a min	d_a max	d_b min	D_a max	r_a max	r_b max				B_1	B_2	
mm							mm						-	-	kg	mm		
200	239	269	229	2,1	2,1	7	210	225	233	299	2	2	0,1	HJ 1040	1,65	13	25,5	
	258	312	243	4	4	2,6	217	239	247	343	3	3	0,15	HJ 240 EC	2,55	14	23	
	258	312	243	4	4	2,6	217	239	262	343	3	3	0,15	HJ 240 EC	2,55	14	23	
	258	312	243	4	4	-	217	-	262	343	3	3	0,15	-	-	-	-	
	-	313	241	4	4	5,1	217	235	245	343	3	3	0,2	-	-	-	-	
	-	353	258	5	5	6	220	254	262	400	4	4	0,15	-	-	-	-	
	-	353	253	5	5	9,4	220	249	257	400	4	4	0,25	-	-	-	-	
	278	353	253	5	5	9,4	220	249	280	400	4	4	0,25	-	-	-	-	
	220	262	297	250	3	3	7,5	233	246	254	327	2,5	2,5	0,1	HJ 1044	2,10	14	27
		284	344	268	4	4	2,3	237	264	270	383	3	3	0,15	HJ 244 EC	3,25	15	25
284		344	268	4	4	2,3	237	264	288	383	3	3	0,15	HJ 244 EC	3,25	15	25	
284		344	268	4	4	-	237	-	288	383	3	3	0,15	-	-	-	-	
-		349	259	4	4	7,9	237	255	264	383	3	3	0,2	-	-	-	-	
-		371	284	5	5	5,2	240	277	288	440	4	4	0,15	-	-	-	-	
307		371	284	5	5	5,2	240	277	311	440	4	4	0,15	-	-	-	-	
-		384	277	5	5	10,4	240	268	280	440	4	4	0,25	-	-	-	-	
240	282	317	270	3	3	7,5	253	266	274	347	2,5	2,5	0,1	HJ 1048	2,25	14	27	
	-	365	295	4	4	3,4	257	288	299	423	3	3	0,15	-	-	-	-	
	313	365	295	4	4	3,4	257	288	317	423	3	3	0,15	-	-	-	-	
	313	365	295	4	4	-	257	-	317	423	3	3	0,15	-	-	-	-	
	-	365	295	4	4	4,3	257	284	299	423	3	3	0,2	-	-	-	-	
	313	365	295	4	4	4,3	257	284	317	423	3	3	0,2	-	-	-	-	
	335	401	310	5	5	5,6	260	302	314	480	4	4	0,15	HJ 348	8,90	22	39,5	
	335	401	310	5	5	5,6	260	302	339	480	4	4	0,15	HJ 348	8,90	22	39,5	
	-	426	299	5	5	10,3	260	295	305	480	4	4	0,25	-	-	-	-	

¹⁾ Permissible axial displacement from the normal position of one bearing ring in relation to the other

Single row cylindrical roller bearings
d 260 – 380 mm

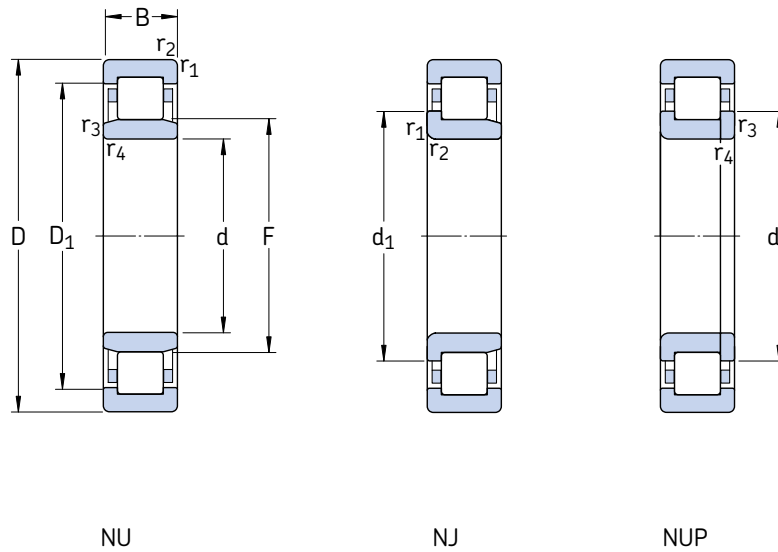

Principal dimensions			Basic load ratings		Fatigue load limit P_u	Speed ratings		Mass	Designation
d	D	B	C	C_0		Refer- ence speed	Limiting speed		
mm			kN		kN	r/min	kg	–	
260	400	65	627	965	96,5	1 800	2 400	29,5	NU 1052 MA
	480	80	1 170	1 700	156	1 400	2 000	68,5	NU 252 MA
	480	80	1 170	1 700	156	1 400	2 000	70,0	NJ 252 MA
	480	80	1 170	1 700	156	1 400	2 000	72,0	NUP 252 MA
	480	130	1 790	3 000	265	1 300	2 000	110	NU 2252 MA
	480	130	1 790	3 000	265	1 300	2 000	112	NJ 2252 MA
280	540	102	1 940	2 700	236	1 100	1 800	125	NU 352 ECMA
	420	65	660	1 060	102	1 700	2 200	31,5	NU 1056 MA
		80	1 140	1 700	153	1 400	1 900	71,5	NU 256 MA
		80	1 140	1 700	153	1 400	1 900	73,0	NJ 256 MA
500	130	2 200	3 250	285	1 200	1 900	115	NU 2256 ECMA	
300	580	175	2 700	4 300	365	1 000	1 700	230	NU 2356 MA
	460	74	858	1 370	129	1 500	2 000	46,5	NU 1060 MA
		74	858	1 370	129	1 500	2 000	47,0	NJ 1060 MA
	540	85	1 420	2 120	183	1 300	1 800	89,5	NU 260 MA
	540	140	2 090	3 450	300	1 200	1 800	145	NU 2260 MA
320	480	74	880	1 430	132	1 400	1 900	48,5	NU 1064 MA
		74	880	1 430	132	1 400	1 900	49,0	NJ 1064 MA
	580	92	1 610	2 450	204	1 200	1 600	115	NU 264 MA
	580	150	3 190	5 000	415	1 000	1 600	180	NU 2264 ECMA
340	520	82	1 080	1 760	156	1 300	1 700	65,0	NU 1068 MA
	520	82	1 080	1 760	156	1 300	1 700	68,0	NJ 1068 MA
	620	165	2 640	4 500	365	1 000	1 500	220	NU 2268 MA
360	540	82	1 100	1 830	163	1 300	1 600	67,5	NU 1072 MA
	650	170	2 920	4 900	400	950	1 400	250	NU 2272 MA
380	560	82	1 140	1 930	170	1 200	1 600	71,0	NU 1076 MA
	560	82	1 140	1 930	170	1 200	1 600	73,0	NJ 1076 MA
	680	175	3 140	5 500	440	900	1 600	275	NU 2276 ECMA

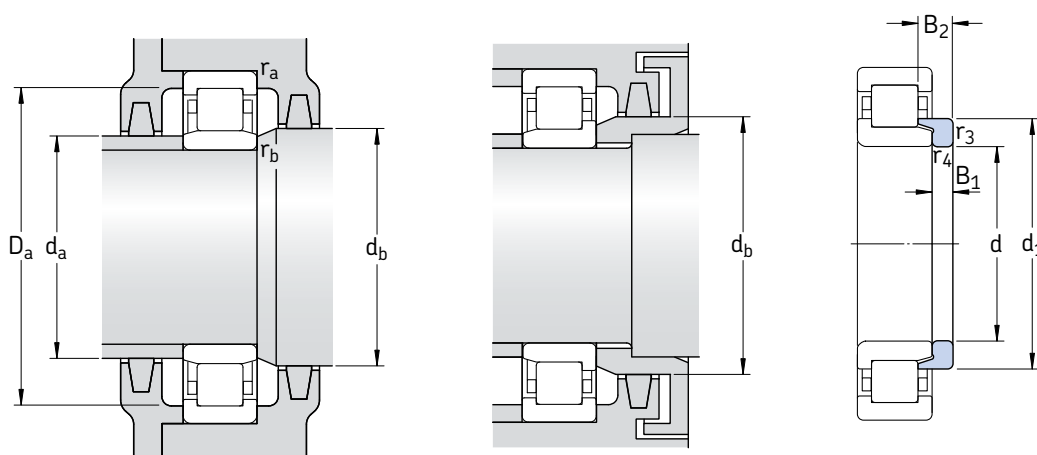

Angle ring

Dimensions							Abutment and fillet dimensions						Calculation factor	Angle ring Designation	Mass	Dimensions	
d	d ₁	D ₁	F	r _{1,2}	r _{3,4}	s ¹⁾	d _a	d _a	d _b	D _a	r _a	r _b	k _r			B ₁	B ₂
mm	mm	mm	mm	min	min	mm	min	max	min	max	max	max	mm	mm	kg	mm	mm
260	309	349	296	4	4	8	276	291	300	384	3	3	0,1	HJ 1052	3,30	16	31,5
	340	397	320	5	5	3,4	280	313	324	460	4	4	0,15	HJ 252	6,20	18	33
	340	397	320	5	5	3,4	280	313	344	460	4	4	0,15	HJ 252	6,20	18	33
	340	397	320	5	5	–	280	–	344	460	4	4	0,15	–			
	–	397	320	5	5	4,3	280	309	324	460	4	4	0,2	–			
340	397	320	5	5	4,3	280	309	344	460	4	4	0,2	–				
–	455	337	6	6	4,2	286	330	341	514	5	5	0,15	–				
280	329	369	316	4	4	8	295	311	320	405	3	3	0,1	HJ 1056	3,55	16	31,5
	–	417	340	5	5	3,8	300	333	344	480	4	4	0,15	–			
	360	417	340	5	5	3,8	300	333	364	480	4	4	0,15	–			
	350	433	327	5	5	10,2	300	320	331	480	4	4	0,2	HJ 2256 EC	6,75	18	38
–	467	362	6	6	6,6	306	347	366	554	5	5	0,25	–				
300	356	402	340	4	4	9,7	317	335	344	443	3	3	0,1	HJ 1060	5,30	19	36
	356	402	340	4	4	9,7	317	335	360	443	3	3	0,1	HJ 1060	5,30	19	36
	–	451	364	5	5	4,8	320	358	368	520	4	4	0,15	–			
–	451	364	5	5	5,6	320	352	368	520	4	4	0,2	–				
320	376	422	360	4	4	9,7	335	355	364	465	3	3	0,1	HJ 1064	5,65	19	36
	376	422	360	4	4	9,7	335	355	380	465	3	3	0,1	HJ 1064	5,65	19	36
	–	485	390	5	5	5,3	340	383	394	560	4	4	0,15	–			
	–	485	390	5	5	5,9	340	377	394	560	4	4	0,2	–			
340	403	455	385	5	5	6,5	358	380	389	502	4	4	0,1	HJ 1068	7,40	21	39,5
	403	455	385	5	5	6,5	358	380	408	502	4	4	0,1	HJ 1068	7,40	21	39,5
	–	515	416	6	6	8	366	401	421	594	5	5	0,2	–			
360	423	475	405	5	5	6,5	378	400	410	522	4	4	0,1	HJ 1072	7,75	21	39,5
	–	542	437	6	6	16,7	386	428	442	624	5	5	0,2	–			
380	443	495	425	5	5	10,8	398	420	430	542	4	4	0,1	HJ 1076	8,25	21	39,5
	443	495	425	5	5	10,8	398	420	448	542	4	4	0,1	HJ 1076	8,25	21	39,5
	–	595	451	6	6	8,3	406	447	455	654	5	5	0,2	–			

¹⁾ Permissible axial displacement from the normal position of one bearing ring in relation to the other

Single row cylindrical roller bearings
d 400 – 800 mm

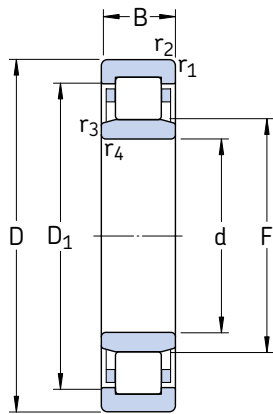

Principal dimensions			Basic load ratings		Fatigue load limit P_u	Speed ratings		Mass	Designation
d	D	B	dynamic C	static C_0		Refer- ence speed	Limiting speed		
mm			kN		kN	r/min	kg	–	
400	600	90	1 380	2 320	204	1 100	1 500	92,5	NU 1080 MA
420	620	90	1 420	2 450	212	1 100	1 400	96,0	NU 1084 MA
440	650	94	1 510	2 650	212	1 000	1 300	105	NU 1088 MA
460	680	100	1 650	2 850	224	950	1 200	115	NU 1092 MA
	830	165	4 180	6 800	510	750	1 100	415	NU 1292 MA
	830	212	5 120	8 650	655	700	1 100	530	NU 2292 MA
480	700	100	1 680	3 000	232	900	1 200	130	NU 1096 MA
500	720	100	1 720	3 100	236	900	1 100	135	NU 10/500 MA
	920	185	5 280	8 500	620	670	950	585	NU 12/500 MA
530	780	112	2 290	4 050	305	800	1 000	190	NU 10/530 MA
	780	145	3 740	7 350	550	670	1 000	255	NU 20/530 ECMA
560	820	115	2 330	4 250	310	750	1 000	210	NU 10/560 MA
	820	150	3 800	7 650	560	630	1 000	290	NU 20/560 ECMA
	1 030	206	7 210	11 200	780	560	800	805	NU 12/560 MA
600	870	118	2 750	5 100	365	700	900	245	NU 10/600 N2MA
	870	155	4 180	8 000	570	600	900	325	NU 20/600 ECMA
	1 090	155	5 610	9 800	670	480	850	710	NU 2/600 ECMA/HB1
630	920	128	3 410	6 200	430	630	1 000	285	NU 10/630 ECN2MA
	920	170	4 730	9 500	670	560	850	400	NU 20/630 ECMA
	1 150	230	8 580	13 700	915	450	700	1 100	NU 12/630 ECMA
670	980	136	3 740	6 800	465	530	800	350	NU 10/670 ECMA
	980	180	5 390	11 000	750	500	800	480	NU 20/670 ECMA
710	1 030	140	4 680	8 500	570	500	750	415	NU 10/710 ECN2MA
	1 030	185	5 940	12 000	815	480	700	540	NU 20/710 ECMA
750	1 090	150	4 730	8 800	585	430	670	490	NU 10/750 ECN2MA
	1 090	195	7 040	14 600	980	430	670	635	NU 20/750 ECM
800	1 150	200	7 040	14 600	950	400	630	715	NU 20/800 ECMA

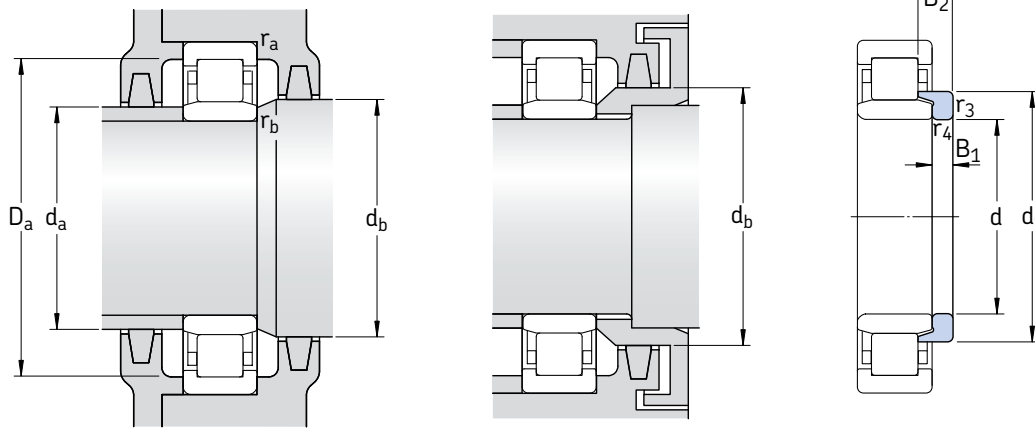

Angle ring

Dimensions							Abutment and fillet dimensions						Calculation factor k_r	Angle ring Designation	Mass B_1	Dimensions B_2	
d	d_1	D_1	F	$r_{1,2}$ min	$r_{3,4}$ min	$s^1)$	d_a min	d_a max	d_b min	D_a max	r_a max	r_b max					
mm							mm						-	-	kg	mm	
400	470	527	450	5	5	14	418	446	455	582	4	4	0,1	HJ 1080	9,75	23	43
420	490	547	470	5	5	14	438	466	475	602	4	4	0,1	HJ 1084	10,0	23	43
440	512	574	493	6	6	14,7	463	488	498	627	5	5	0,1	HJ 1088	11,5	24	45
460	537	600	516	6	6	15,9	483	511	521	657	5	5	0,1	HJ 1092	14,0	25	48
	-	715	554	7,5	7,5	6,4	492	542	559	798	6	6	0,14	-			
	-	706	554	7,5	7,5	16,5	492	542	559	798	6	6	0,2	-			
480	557	620	536	6	6	15,9	503	531	541	677	5	5	0,1	HJ 1096	14,5	25	48
500	577	640	556	6	6	11,2	523	550	561	697	5	5	0,1	HJ 10/500	15,0	25	48
	-	728	576	7,5	7,5	14,5	532	564	581	798	6	6	0,21	-			
530	-	692	593	6	6	10,4	553	585	598	757	5	5	0,1	-	-	-	-
	-	704	591	6	6	6,8	553	587	596	757	5	5	0,14	-			
560	648	726	625	6	6	12,3	583	617	630	797	5	5	0,1	HJ 10/560	21,0	27,5	53
	-	726	625	6	6	12,3	583	617	630	797	5	5	0,1	-			
	-	741	626	6	6	6,7	583	616	631	797	5	5	0,14	-			
600	695	779	667	6	6	14	623	658	672	847	5	5	0,1	HJ 10/600	27,5	31	55
	-	793	661	6	6	6,1	623	652	667	847	5	5	0,14	-			
	-	925	749	9,5	9,5	3	640	743	755	1 050	8	8	0,17	-			
630	-	837	702	7,5	7,5	6,2	658	691	706	892	6	6	0,1	-	-	-	-
	-	832	699	7,5	7,5	8,7	658	690	705	892	6	6	0,14	-			
	-	1 005	751	12	12	13,5	678	735	757	1 102	10	10	0,17	-			
670	-	891	747	7,5	7,5	7,9	698	736	753	952	6	6	0,1	-	-	-	-
	-	890	746	7,5	7,5	7	698	736	752	952	6	6	0,14	-			
710	-	939	778	7,5	7,5	8	738	769	783	1 002	6	6	0,1	-	-	-	-
	-	939	787	7,5	7,5	10	738	774	793	1 002	6	6	0,14	-			
750	-	993	832	7,5	7,5	3	778	823	838	1 062	6	6	0,1	-	-	-	-
	-	993	832	7,5	7,5	2	778	823	838	1 062	6	6	0,14	-			
800	-	1 051	882	7,5	7,5	2	828	868	888	1 122	6	6	0,14	-	-	-	-

¹⁾ Permissible axial displacement from the normal position of one bearing ring in relation to the other



Single row full complement cylindrical roller bearings

Designs	560
NCF design.....	560
NJG design.....	560
Bearing data – general	561
Dimensions.....	561
Tolerances.....	561
Radial internal clearance.....	561
Misalignment.....	561
Influence of operating temperature on bearing material.....	561
Minimum load.....	561
Dynamic axial load carrying capacity	562
Equivalent dynamic bearing load.....	563
Equivalent static bearing load.....	563
Supplementary designations.....	563
Product table	564

Designs

Full complement cylindrical roller bearings incorporate a maximum number of rollers and are therefore suitable for very heavy radial loads. However, they cannot operate at the same high speeds as caged design cylindrical roller bearings. The standard SKF range of single row full complement cylindrical roller bearings consist of the NCF and NJG designs.

NCF design

NCF design bearings (→ **fig. 1**) have two integral flanges on the inner ring and one integral flange on the outer ring and can thus support axial loads acting in one direction and provide axial shaft location in one direction. A retaining ring at the flangeless side of the outer ring holds the bearing assembly together. The axial internal clearance in the bearing is provided in the product table and is designed to permit small axial displacements of the shaft in relation to the housing, e.g. as a result of thermal expansion of the shaft, to be accommodated in the bearing.

NJG design

NJG design bearings (→ **fig. 2**) comprise the heavy dimension series 23 and are intended for very heavily loaded, slow speed applications. These bearings have two integral flanges on the outer ring and one integral flange on the inner ring and can thus support axial loads acting in one direction and provide axial shaft location in one direction. In contrast to the other full complement bearing designs, NJG design bearings have a self-retaining roller complement. The outer ring with its two integral flanges together with the roller complement can therefore be withdrawn from the inner ring, without having to take any precautions to prevent the rollers from falling out. This simplifies mounting and dismounting.

Fig. 1

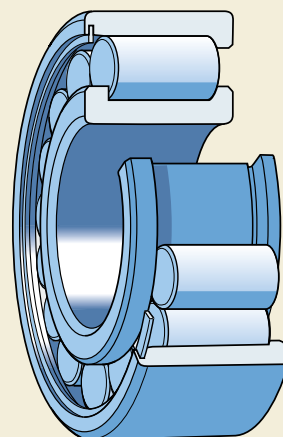
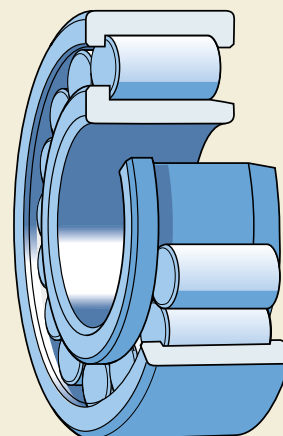

Fig. 2



Bearing data – general

Dimensions

The boundary dimensions of SKF single row full complement cylindrical roller bearings are in accordance with ISO 15:1998.

Tolerances

SKF single row full complement cylindrical roller bearings are produced to Normal tolerances. The values for the tolerances correspond to ISO 492:2002 and can be found in **table 3** on **page 125**.

Radial internal clearance

SKF single row full complement cylindrical roller bearings are produced with Normal radial internal clearance as standard. The majority of the bearings are also available with the greater C3 radial internal clearance. The values correspond to ISO 5753:1991 and are provided in **table 1** on **page 513**. The clearance limits apply to unmounted bearings under zero measuring load.

Misalignment

The ability of single row full complement cylindrical roller bearings to accommodate angular misalignment of the inner ring with respect to the outer ring is limited to a few minutes of arc. The actual values are

- 4 minutes of arc for bearings of the narrow dimension series 18, and
- 3 minutes of arc for bearings of the wide dimension series 22, 23, 28, 29 and 30.

The above guideline values apply provided the position of the shaft and housing axes remains constant. A larger misalignment is possible, but may result in reduced bearing service life. In such cases, please contact the SKF application engineering service.

Influence of operating temperature on bearing material

SKF single row full complement cylindrical roller bearings undergo a special heat treatment. They can operate at temperatures of up to +150 °C.

Minimum load

In order to provide satisfactory operation, single row full complement cylindrical roller bearings, like all ball and roller bearings, must always be subjected to a given minimum load, particularly if they are to operate at relatively high speeds ($n > 0,5$ times the reference speed) or are subjected to high accelerations or rapid changes in the direction of the load. Under such conditions, the inertia forces of the rollers and the friction in the lubricant, can have a detrimental effect on the rolling conditions in the bearing arrangement and may cause damaging sliding movements to occur between the rollers and raceways.

The requisite minimum load to be applied to single row full complement cylindrical roller bearings can be estimated using

$$F_{rm} = k_r \left(6 + \frac{4n}{n_r} \right) \left(\frac{d_m}{100} \right)^2$$

where

F_{rm} = minimum radial load, kN

k_r = minimum load factor

0,1 for bearing series 18

0,11 for bearing series 28

0,2 for bearing series 29

0,3 for bearing series 30 and 22

0,35 for bearing series 23

n = rotational speed, r/min

n_r = reference speed, r/min

(→ product table)

d_m = bearing mean diameter

= 0,5 (d + D), mm

When starting up at low temperatures or when the lubricant is highly viscous, even greater minimum loads may be required. The weight of the components supported by the bearing, together with external forces, generally exceeds the requisite minimum load. If this is not the case, the single row full complement cylindrical roller bearing must be subjected to an additional radial load.

Single row full complement cylindrical roller bearings

Dynamic axial load carrying capacity

Single row full complement cylindrical roller bearings with flanges on both inner and outer rings can support axial loads in one direction. Their axial load carrying capacity is primarily determined by the ability of the sliding surfaces of the roller end/flange contact to support loads. Factors having the greatest effect on this ability are the lubrication, operating temperature and heat dissipation from the bearing.

Assuming the conditions cited below, the permissible axial load can be calculated with sufficient accuracy from

$$F_{ap} = \frac{k_1 C_0 10^4}{n (d + D)} - k_2 F_r$$

where

F_{ap} = permissible axial load, kN

C_0 = basic static load rating, kN

F_r = actual radial bearing load, kN

n = rotational speed, r/min

d = bearing bore diameter, mm

D = bearing outside diameter, mm

k_1 = a factor

1 for oil lubrication

0,5 for grease lubrication

k_2 = a factor

0,3 for oil lubrication

0,15 for grease lubrication

The above equation is based on conditions that are considered typical for normal bearing operation, i.e.

- a difference of 60 °C between the bearing operating temperature and the ambient temperature
- a specific heat loss from the bearing of 0,5 mW/mm² °C with reference to the bearing outside diameter surface ($\pi D B$)
- a viscosity ratio $\kappa \geq 2$.

For grease lubrication the viscosity of the base oil in the grease may be used. If κ is less than 2, the friction will increase and there will be more wear. These effects can be reduced at low speeds, for example by using oils with AW (anti-wear) and/or EP (extreme pressure) additives.

Where axial loads act for longer periods and the bearings are grease lubricated, it is advisable to use a grease that has good oil bleeding

properties at the operating temperatures (> 3 % according to DIN 51 817). Frequent relubrication is also recommended.

The values of the permissible load F_{ap} obtained from the heat balance equation are valid for a continuously acting constant axial load and adequate lubricant supply to the roller end/flange contacts. Where axial loads act only for short periods, the values can be multiplied by a factor of 2, or for shock loads by a factor of 3, provided the limits given in the following with regard to flange strength are not exceeded.

To avoid any risk of flange breakage, the constantly acting axial load applied to the bearings should never exceed

$$F_{a \max} = 0,0023 D^{1,7}$$

When acting only occasionally and for brief periods, the axial load applied to the bearings should never exceed

$$F_{a \max} = 0,007 D^{1,7}$$

where

$F_{a \max}$ = maximum constantly or occasionally acting axial load, kN

D = bearing outside diameter, mm

To obtain an even flange load and provide sufficient running accuracy of the shaft when single row full complement cylindrical roller bearings are subjected to heavy axial loads, axial runout and the size of the abutment surfaces of adjacent components become particularly important.

If shaft deflection occurs together with an axial load, the inner ring flange should only be supported to half its height (\rightarrow **fig. 3**) so that it is not subjected to damaging alternating stresses. The recommended shaft abutment diameter d_{as} can be obtained from the product table.

Where misalignment between the inner and outer rings exceeds 1 minute of arc, the action of the load on the flange changes considerably. As a result, the safety factors implicit in the guideline values may not be adequate. In these cases, contact the SKF application engineering service.

Equivalent dynamic bearing load

For non-locating bearings

$$P = F_r$$

If the bearings are used to locate a shaft in one direction, the equivalent dynamic bearing load should be calculated using

$$P = F_r \quad \text{when } F_a/F_r \leq e$$
$$P = 0,92 F_r + Y F_a \quad \text{when } F_a/F_r > e$$

where

e = limiting value

= 0,2 for bearings in the 18 series

= 0,3 for bearings in the 22, 23, 28, 29
and 30 series

Y = axial load factor

= 0,6 for bearings in the 18 series

= 0,4 for bearings in the 22, 23, 28, 29
and 30 series

Since axially loaded single row full complement cylindrical roller bearings only operate satisfactorily when they are subjected to a simultaneously acting radial load, the ratio F_a/F_r should not exceed 0,5.

Equivalent static bearing load

$$P_0 = F_r$$

Supplementary designations

The designation suffixes used to identify certain features of SKF single row full complement cylindrical roller bearings are explained in the following.

- CV** Modified internal design, full complement roller set
- C3** Radial internal clearance greater than Normal
- HA1** Case-hardened inner and outer rings
- HB1** Bainite hardened inner and outer rings
- L4B** Bearing rings and rolling elements with special surface coating
- L5B** Rolling elements with special surface coating
- V** Full complement of rollers (without cage)
- VH** Full complement of rollers (without cage), self-retaining

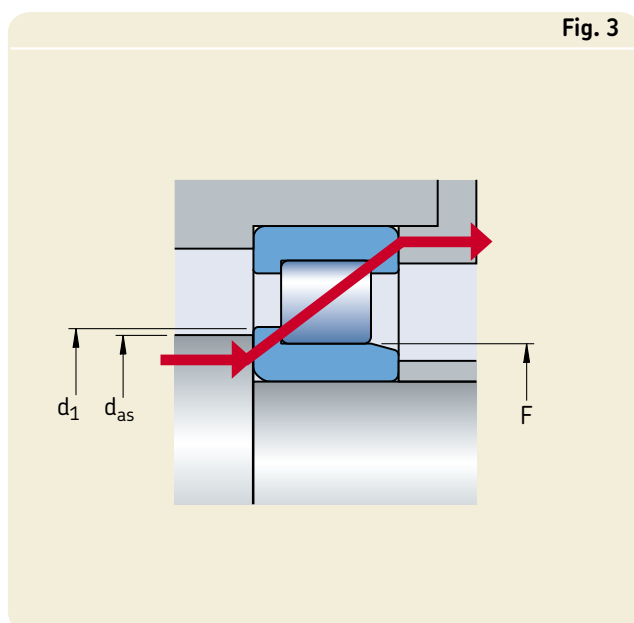

Single row full complement cylindrical roller bearings
d 20 – 75 mm

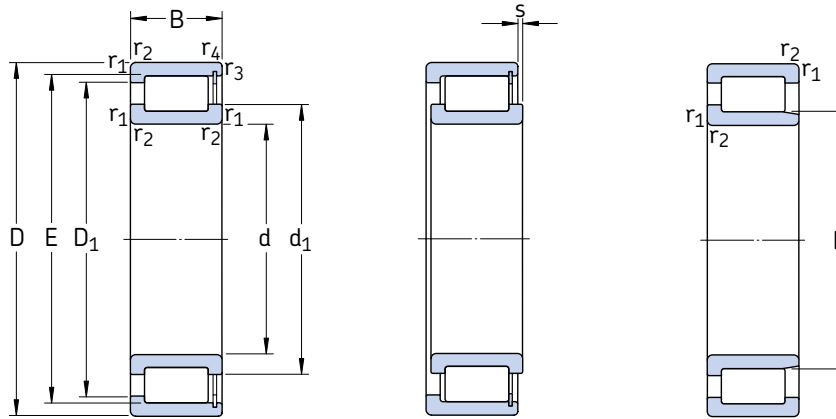

NCF

NJG

Principal dimensions			Basic load ratings		Fatigue load limit P_u	Speed ratings		Mass	Designation
d	D	B	dynamic	static		Reference speed	Limiting speed		
mm			C	C_0	kN	r/min	kg	–	
20	42	16	28,1	28,5	3,1	8 500	10 000	0,11	NCF 3004 CV
25	47	16	31,9	35,5	3,8	7 000	9 000	0,12	NCF 3005 CV
	62	24	68,2	68	8,5	4 500	5 600	0,38	NJG 2305 VH
30	55	19	39,6	44	5	6 000	7 500	0,20	NCF 3006 CV
	72	27	84,2	86,5	11	4 000	4 800	0,56	NJG 2306 VH
35	62	20	48,4	56	6,55	5 300	6 700	0,26	NCF 3007 CV
	80	31	108	114	14,3	3 400	4 300	0,75	NJG 2307 VH
40	68	21	57,2	69,5	8,15	4 800	6 000	0,31	NCF 3008 CV
	90	33	145	156	20	3 000	3 600	1,00	NJG 2308 VH
45	75	23	60,5	78	9,15	4 300	5 300	0,40	NCF 3009 CV
	100	36	172	196	25,5	2 800	3 400	1,45	NJG 2309 VH
50	80	23	76,5	98	11,8	4 000	5 000	0,43	NCF 3010 CV
55	90	26	105	140	17,3	3 400	4 300	0,64	NCF 3011 CV
	120	43	233	260	33,5	2 200	2 800	2,30	NJG 2311 VH
60	85	16	55	80	9,15	3 600	4 500	0,29	NCF 2912 CV
	95	26	106	146	18,3	3 400	4 000	0,69	NCF 3012 CV
65	90	16	58,3	88	10,2	3 200	4 000	0,31	NCF 2913 CV
	100	26	112	163	20	3 000	3 800	0,73	NCF 3013 CV
	140	48	303	360	46,5	1 900	2 400	3,55	NJG 2313 VH
70	100	19	76,5	116	13,7	3 000	3 800	0,49	NCF 2914 CV
	110	30	128	173	22,4	2 800	3 600	1,02	NCF 3014 CV
	150	51	336	400	50	1 800	2 200	4,40	NJG 2314 VH
75	105	19	79,2	125	14,6	2 800	3 600	0,52	NCF 2915 CV
	115	30	134	190	24,5	2 600	3 200	1,06	NCF 3015 CV
	160	55	396	480	60	1 600	2 000	5,35	NJG 2315 VH

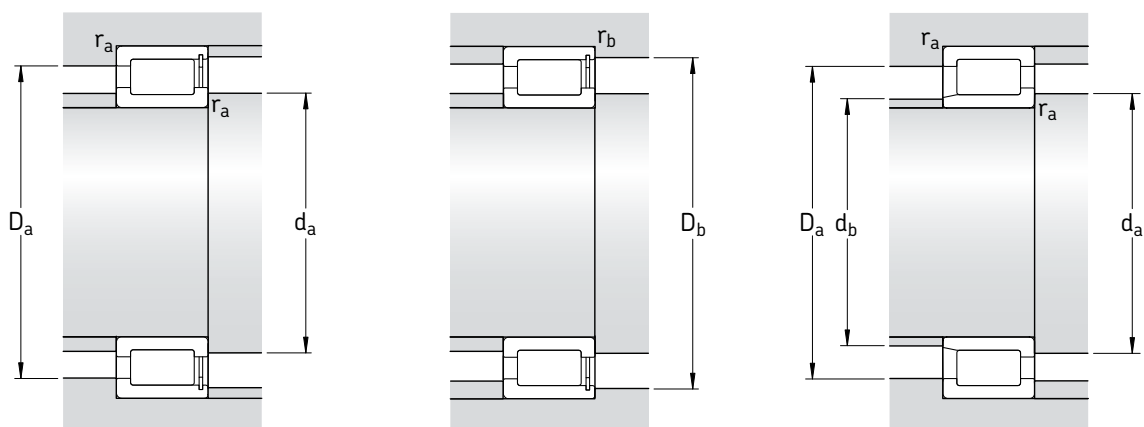

Dimensions

Abutment and fillet dimensions

d	d ₁ ~	D ₁ ~	E, F	r _{1,2} min	r _{3,4} min	s ¹⁾	d _a min	d _{as} ²⁾	d _b max	D _a max	D _b max	r _a max	r _b max
mm							mm						
20	29	33	36,8	0,6	0,6	1,5	24	26,9	–	38	40	0,6	0,6
25	34	39	42,5	0,6	0,6	1,5	29	32,3	–	43	45	0,6	0,6
	36,1	48,2	31,74	1,1	–	1,7	32	33,9	30	55	–	1	–
30	40	45	49,6	1	1	2	35	37,8	–	50	52	1	1
	43,2	56,4	38,36	1,1	–	1,8	37	40,8	36	65	–	1	–
35	45	51	55,5	1	1	2	40	42,8	–	57	59	1	1
	50,4	65,8	44,75	1,5	–	2	44	47,6	42	71	–	1,5	–
40	50	58	61,7	1	1	2	45	47,9	–	63	65	1	1
	57,6	75,2	51,15	1,5	–	2,4	49	54,4	49	81	–	1,5	–
45	55	62	66,9	1	1	2	50	53	–	70	72	1	1
	62,5	80,1	56,14	1,5	–	2,4	54	59,3	54	91	–	1,5	–
50	59	68	72,3	1	1	2	55	56,7	–	75	77	1	1
	–	–	–	–	–	–	–	–	–	–	–	–	–
55	68	79	83,5	1,1	1,1	2	61	65,8	–	84	86	1	1
	75,5	98,6	67,14	2	–	2,6	66	71,3	66	109	–	2	–
60	69	74,5	78,65	1	1	1	65	66,8	–	80	80	1	1
	71	82	86,7	1,1	1,1	2	66	68,9	–	89	91	1	1
65	75,5	81	85,35	1	1	1	70	73,4	–	85	85	1	1
	78	88	93,1	1,1	1,1	2	71	75,6	–	94	96	1	1
	89,9	116	80,71	2,1	–	3	77	85,3	78	128	–	2	–
70	80,5	88,5	92,5	1	1	1	75	78,5	–	95	95	1	1
	81	95	100,3	1,1	1,1	3	76	78,7	–	104	106	1	1
	93,8	121	84,22	2,1	–	3	82	89	81	138	–	2	–
75	86	93	97,6	1	1	1	80	83,8	–	100	100	1	1
	89	103	107,9	1,1	1,1	3	81	86,5	–	109	111	1	1
	101	131	91,24	2,1	–	3	87	96,1	88	148	–	2	–

¹⁾ Permissible axial displacement from the normal position of one bearing ring in relation to the other

²⁾ Recommended shaft abutment diameter for axially loaded bearings → page 562

Single row full complement cylindrical roller bearings
d 80 – 150 mm

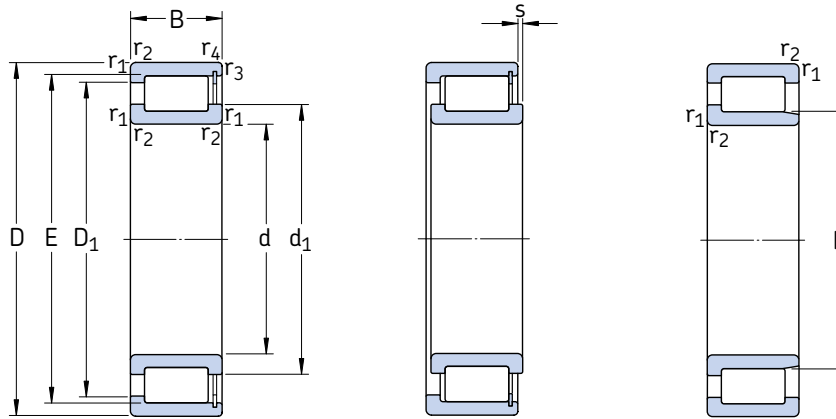

NCF

NJG

Principal dimensions			Basic load ratings dynamic static		Fatigue load limit P_u	Speed ratings Reference speed Limiting speed		Mass	Designation
d	D	B	C	C_0					
mm			kN		kN	r/min		kg	–
80	110	19	80,9	132	15,6	2 600	3 400	0,55	NCF 2916 CV
	125	34	165	228	29	2 400	3 000	1,43	NCF 3016 CV
	170	58	457	570	71	1 500	1 900	6,40	NJG 2316 VH
85	120	22	102	166	20	2 600	3 200	0,81	NCF 2917 CV
	130	34	172	236	30	2 400	3 000	1,51	NCF 3017 CV
	180	60	484	620	76,5	1 400	1 800	7,40	NJG 2317 VH
90	125	22	105	176	20,8	2 400	3 000	0,84	NCF 2918 CV
	140	37	198	280	35,5	2 200	2 800	1,97	NCF 3018 CV
	190	64	528	670	81,5	1 400	1 800	8,75	NJG 2318 VH
100	140	24	128	200	24,5	2 200	2 600	1,14	NCF 2920 CV
	150	37	209	310	37,5	2 000	2 600	2,15	NCF 3020 CV
	215	73	682	865	104	1 200	1 500	13,0	NJG 2320 VH
110	150	24	134	220	26	1 900	2 400	1,23	NCF 2922 CV
	170	45	275	400	47,5	1 800	2 200	3,50	NCF 3022 CV
	240	80	858	1 060	122	1 100	1 300	17,5	NJG 2322 VH
120	165	27	172	290	34,5	1 800	2 200	1,73	NCF 2924 CV
	180	46	292	440	52	1 700	2 000	3,80	NCF 3024 CV
	215	58	512	735	85	1 400	1 700	9,05	NCF 2224 V
	260	86	952	1 250	140	1 000	1 200	22,5	NJG 2324 VH
130	180	30	205	360	40,5	1 600	2 000	2,33	NCF 2926 CV
	200	52	413	620	72	1 500	1 900	5,80	NCF 3026 CV
	280	93	1 080	1 430	156	950	1 200	28,0	NJG 2326 VH
140	190	30	220	390	43	1 500	1 900	2,42	NCF 2928 CV
	210	53	440	680	78	1 400	1 800	6,10	NCF 3028 CV
	250	68	693	1 020	114	1 200	1 500	14,5	NCF 2228 V
	300	102	1 210	1 600	173	850	1 100	35,5	NJG 2328 VH
150	210	36	292	490	55	1 400	1 700	3,77	NCF 2930 CV
	225	56	457	710	80	1 300	1 600	7,50	NCF 3030 CV
	270	73	792	1 180	132	1 100	1 400	18,4	NCF 2230 V
	320	108	1 450	1 930	196	800	1 000	42,5	NJG 2330 VH

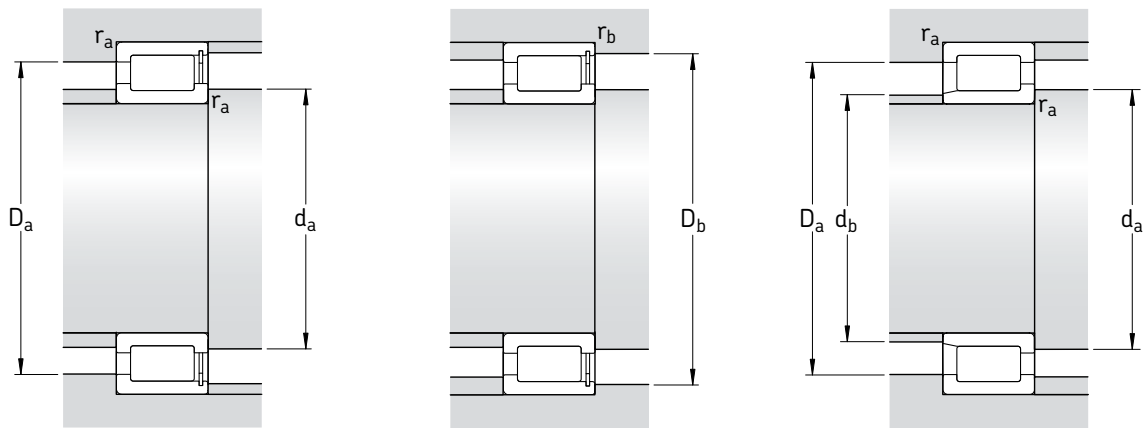

Dimensions

Abutment and fillet dimensions

d	d ₁ ~	D ₁ ~	E, F	r _{1,2} min	r _{3,4} min	s ¹⁾	d _a min	d _{as} ²⁾	d _b max	D _a max	D _b max	r _a max	r _b max
mm							mm						
80	90,5	99	102,7	1	1	1	85	88,6	–	105	105	1	1
	95	111	117	1,1	1,1	4	86	92	–	119	121	1	1
	109	141	98,26	2,1	–	4	92	104	95	158	–	2	–
85	96	105	109,7	1,1	1,1	1	91	93,9	–	114	114	1	1
	99	116	121,4	1,1	1,1	4	91	96,2	–	124	126	1	1
	118	149	107	3	–	4	99	113	104	166	–	2,5	–
90	102	111	115,6	1,1	1,1	1	96	99,8	–	119	119	1	1
	106	124	130,1	1,5	1,5	4	97	103	–	133	135	1,5	1,5
	117	152	105,3	3	–	4	104	111	105	176	–	2,5	–
100	114	126	130,6	1,1	1,1	1,5	106	111	–	134	134	1	1
	115	134	139,7	1,5	1,5	4	107	112	–	143	145	1,5	1,5
	133	173	119,3	3	–	4	114	126	119	201	–	2,5	–
110	124	136	141,1	1,1	1,1	1,5	116	122	–	144	144	1	1
	127	149	156,1	2	2	5,5	120	124	–	160	165	2	2
	151	198	134,3	3	–	5	124	143	130	226	–	2,5	–
120	136	149	154,3	1,1	1,1	1,5	126	133	–	159	159	1	1
	139	160	167,6	2	2	5,5	130	135	–	170	175	2	2
	150	184	192,32	2,1	2,1	4	131	145	–	204	204	2	2
	164	213	147,4	3	–	5	134	156	142	246	–	2,5	–
130	147	161	167,1	1,5	1,5	2	137	143	–	173	173	1,5	1,5
	149	175	183	2	1	5,5	140	148	–	190	195	2	1
	175	226	157,9	4	–	6	147	166	153	263	–	3	–
140	158	173	180	1,5	1,5	2	147	155	–	183	183	1,5	1,5
	163	189	197	2	1	5,5	150	159	–	200	205	2	1
	173	212	221,9	3	3	5	143	167	–	127	127	2,5	2,5
	187	241	168,5	4	–	6,5	157	178	163	283	–	3	–
150	169	189	196,4	2	2	2,5	159	166	–	201	201	2	2
	170	198	206	2,1	1,1	7	161	167	–	214	234	2	1
	184	227	236,7	3	3	6	153	178	–	137	137	2,5	2,5
	202	261	182,5	4	–	6,5	167	192	178	303	–	3	–

¹⁾ Permissible axial displacement from the normal position of one bearing ring in relation to the other

²⁾ Recommended shaft abutment diameter for axially loaded bearings → **page 562**

Single row full complement cylindrical roller bearings
d 160 – 260 mm

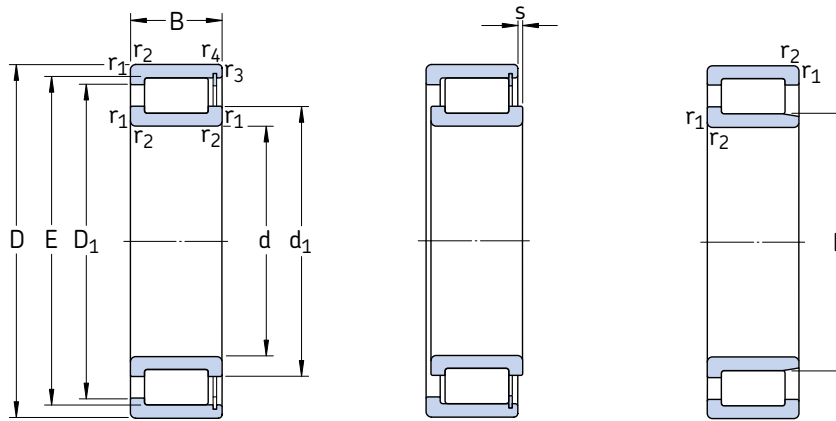

NCF

NJG

Principal dimensions			Basic load ratings		Fatigue load limit P_u	Speed ratings		Mass	Designation
d	D	B	dynamic	static		Reference speed	Limiting speed		
mm			kN		kN	r/min		kg	–
160	220	36	303	530	58,5	1 300	1 600	4,00	NCF 2932 CV
	240	60	512	800	90	1 200	1 500	9,10	NCF 3032 CV
	290	80	990	1 500	160	950	1 200	23,0	NCF 2232 V
170	230	36	314	560	60	1 200	1 500	4,30	NCF 2934 CV
	260	67	671	1 060	118	1 100	1 400	12,5	NCF 3034 CV
	310	86	1 100	1 700	176	900	1 100	28,7	NCF 2234 V
	360	120	1 760	2 450	236	700	900	59,5	NJG 2334 VH
180	250	42	391	695	75	1 100	1 400	6,20	NCF 2936 CV
	280	74	781	1 250	134	1 100	1 300	16,5	NCF 3036 CV
	380	126	1 870	2 650	255	670	800	69,5	NJG 2336 VH
190	260	42	440	780	81,5	1 100	1 400	6,50	NCF 2938 CV
	290	75	792	1 290	140	1 000	1 300	17,0	NCF 3038 CV
	340	92	1 250	1 900	196	800	1 000	35,7	NCF 2238 V
	400	132	2 160	3 000	280	630	800	80,0	NJG 2338 VH
200	250	24	176	335	32,5	1 100	1 400	2,60	NCF 1840 V
	280	48	528	965	100	1 000	1 300	9,10	NCF 2940 CV
	310	82	913	1 530	160	950	1 200	22,5	NCF 3040 CV
	420	138	2 290	3 200	290	600	750	92,0	NJG 2340 VH
220	270	24	183	365	34,5	1 000	1 200	2,85	NCF 1844 V
	300	48	550	1 060	106	950	1 200	9,90	NCF 2944 CV
	340	90	1 080	1 800	186	850	1 100	29,5	NCF 3044 CV
	400	108	1 830	2 750	255	700	850	58,0	NCF 2244 V
	460	145	2 550	3 550	320	530	670	111	NJG 2344 VH
240	300	28	260	510	47,5	900	1 100	4,40	NCF 1848 V
	320	48	583	1 140	114	850	1 100	10,6	NCF 2948 CV
	360	92	1 140	1 960	200	800	1 000	32,0	NCF 3048 CV
	500	155	2 810	3 900	345	500	630	147	NJG 2348 VH
260	320	28	270	550	50	800	1 000	4,75	NCF 1852 V
	360	60	737	1 430	143	750	950	18,5	NCF 2952 CV
	400	104	1 540	2 550	250	700	900	46,5	NCF 3052 CV
	540	165	3 410	4 800	415	430	530	177	NJG 2352 VH

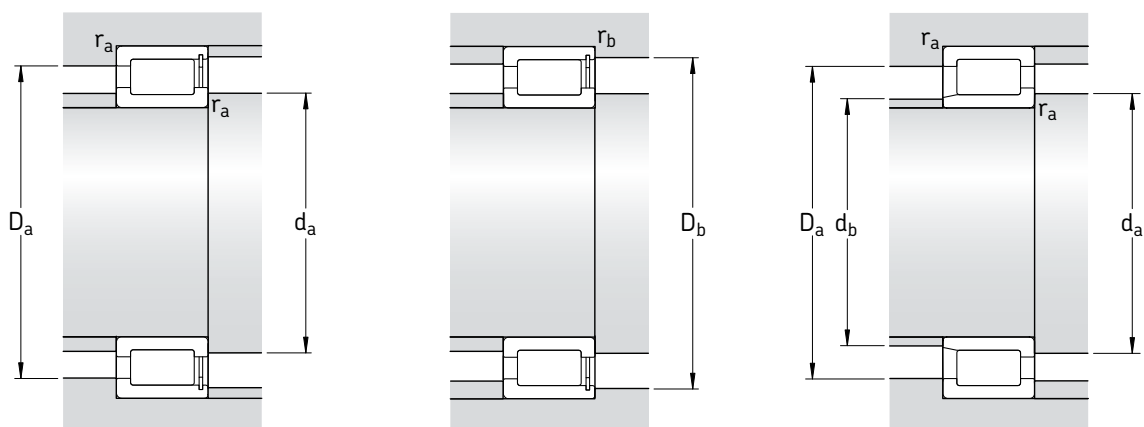

Dimensions

Abutment and fillet dimensions

d	d ₁ ~	D ₁ ~	E, F	r _{1,2} min	r _{3,4} min	s ¹⁾	d _a min	d _{as} ²⁾	d _b max	D _a max	D _b max	r _a max	r _b max
mm							mm						
160	180	200	207,2	2	2	2,5	169	177	–	211	211	2	2
	185	215	224	2,1	1,1	7	171	180	–	229	304	2	1
	208	255	266,4	3	3	6	163	201	–	147	147	2,5	2,5
170	191	211	218	2	2	2,5	179	188	–	221	221	2	2
	198	232	242	2,1	1,1	7	181	192	–	249	274	2	1
	219	269	281,1	4	4	7	185	212	–	295	295	3	3
	227	291	203,55	4	–	7	187	214	200	343	–	3	–
180	203	223	232	2	2	2,5	189	199	–	241	241	2	2
	212	248	260	2,1	2,1	7	191	206	–	269	269	2	2
	245	309	221,7	4	–	8	197	232	216	363	–	3	–
190	212	236	244	2	2	2,5	199	208	–	251	251	2	2
	222	258	269	2,1	2,1	9	201	216	–	279	279	2	2
	243	296	311	4	4	7	205	235	–	325	325	3	3
	250	320	224,5	5	–	8	210	237	222	380	–	4	–
200	218	231	237,5	1,5	1,1	1,8	207	215	–	243	245	1,5	1
	226	253	262	2,1	2,1	3	211	222	–	269	269	2	2
	237	275	287	2,1	2,1	9	211	230	–	299	299	2	2
	266	342	238,6	5	–	9	220	252	232	400	–	4	–
220	238	252	258	1,5	1,1	1,8	227	235	–	263	265	1,5	1
	247	274	283	2,1	2,1	3	231	242	–	289	289	2	2
	255	298	312	3	3	9	233	248	–	327	327	2,5	2,5
	277	349	366	4	4	8	235	260	–	385	385	3	3
	295	383	266,7	5	–	10	240	281	260	440	–	4	–
240	263	279	287	2	1,1	1,8	249	259	–	291	295	2	1
	267	294	303	2,1	2,1	3	251	263	–	309	309	2	2
	278	321	335	3	3	11	253	271	–	347	347	2,5	2,5
	310	403	280,6	5	–	10	260	295	282	480	–	4	–
260	283	299	307,2	2	1,1	1,8	270	279	–	310	315	2	1
	291	323	333	2,1	2,1	3,5	271	286	–	349	349	2	2
	304	358	376	4	4	11	275	295	–	385	385	3	3
	349	456	315,6	6	–	11	286	332	309	514	–	5	–

¹⁾ Permissible axial displacement from the normal position of one bearing ring in relation to the other

²⁾ Recommended shaft abutment diameter for axially loaded bearings → [page 562](#)

Single row full complement cylindrical roller bearings
d 280 – 440 mm

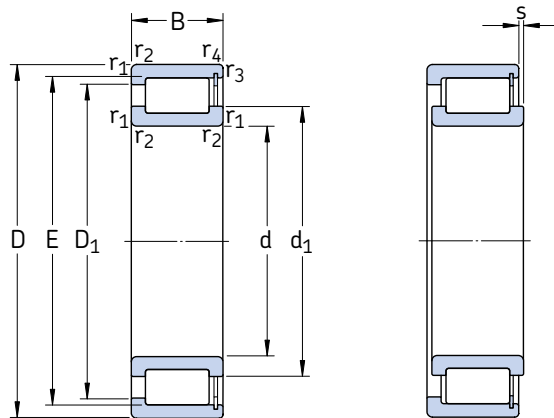

Principal dimensions			Basic load ratings		Fatigue load limit P_u	Speed ratings		Mass	Designation
d	D	B	C	C_0		Refer- ence speed	Limiting speed		
mm			kN		kN	r/min	kg	–	
280	350	33	341	695	64	750	950	7,10	NCF 1856 V
	380	60	880	1 730	166	700	900	19,7	NCF 2956 CV
	420	106	1 570	2 650	260	670	850	50,0	NCF 3056 CV
300	380	38	418	850	75	670	850	10,0	NCF 1860 V
	420	72	1 120	2 200	208	670	800	31,2	NCF 2960 CV
	460	118	1 900	3 250	300	600	750	69,0	NCF 3060 CV
320	400	38	440	900	80	630	800	10,5	NCF 1864 V
	440	72	1 140	2 360	220	600	750	32,9	NCF 2964 CV
	480	121	1 980	3 450	310	560	700	74,5	NCF 3064 CV
340	420	38	446	950	83	600	750	11,0	NCF 1868 V
	460	72	1 190	2 500	228	560	700	35,0	NCF 2968 CV
	520	133	2 380	4 150	355	530	670	100	NCF 3068 CV
360	440	38	402	900	76,5	560	700	11,5	NCF 1872 V
	480	72	1 230	2 600	240	530	670	36,5	NCF 2972 CV
	540	134	2 420	4 300	365	500	630	105	NCF 3072 CV
380	480	46	627	1 290	114	530	670	19,5	NCF 1876 V
	520	82	1 570	3 250	300	500	630	52,5	NCF 2976 CV
	560	135	2 510	4 550	380	480	600	110	NCF 3076 CV
400	500	46	627	1 340	118	500	630	20,5	NCF 1880 V
	540	82	1 650	3 450	310	480	600	54,5	NCF 2980 CV
	600	148	2 970	5 500	450	450	560	145	NCF 3080 CV
420	520	46	660	1 430	122	480	600	21,0	NCF 1884 V
	560	82	1 650	3 600	315	450	560	57,0	NCF 2984 CV
	620	150	3 030	5 700	455	430	530	150	NCF 3084 CV
440	540	46	671	1 460	125	450	560	22,0	NCF 1888 V
	540	60	1 060	2 700	232	450	560	29,0	NCF 2888 V
	600	95	2 010	4 400	380	430	530	80,5	NCF 2988 V
	650	157	3 580	6 550	520	400	500	175	NCF 3088 CV

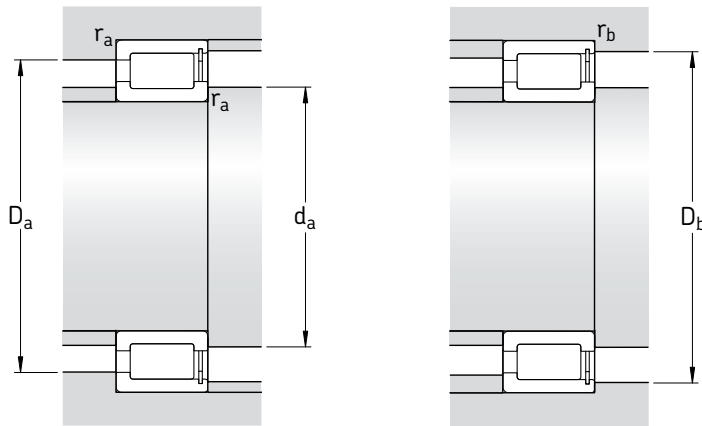

Dimensions

Abutment and fillet dimensions

d	d ₁ ~	D ₁ ~	E	r _{1,2} min	r _{3,4} min	s ¹⁾	d _a min	d _{as} ²⁾	D _a max	D _b max	r _a max	r _b max
mm							mm					
280	307	325	334	2	1,1	2,5	289	303	341	344	2	1
	314	348	359,1	2,1	2,1	3,5	291	309	369	369	2	2
	319	373	391	4	4	11	295	310	405	405	3	3
300	331	353	363	2,1	1,5	3	311	326	369	373	2	1,5
	341	375	390,5	3	3	5	313	334	407	407	2,5	2,5
	355	413	433	4	4	14	315	344	445	445	3	3
320	351	373	383	2,1	1,5	3	331	346	389	393	2	1,5
	359	401	411	3	3	5	333	353	427	427	2,5	2,5
	368	434	449	4	4	14	335	359	465	465	3	3
340	371	393	403	2,1	1,5	3	351	366	409	413	2	1,5
	378	421	431	3	3	5	353	373	447	447	2,5	2,5
	395	468	485	5	5	14	358	384	502	502	4	4
360	388	413	418,9	2,1	1,5	4,5	371	384	429	433	2	1,5
	404	437	451,5	3	3	5	373	396	467	467	2,5	2,5
	412	486	503	5	5	14	378	402	522	522	4	4
380	416	448	458	2,1	1,5	3,5	391	411	469	473	2	1,5
	427	474	488	4	4	5	395	420	505	505	3	3
	431	504	521	5	5	14	398	420	542	542	4	4
400	433	465	475	2,1	1,5	3,5	411	428	489	493	2	1,5
	449	499	511	4	4	5	415	442	525	525	3	3
	460	540	558	5	5	14	418	449	582	582	4	4
420	457	489	499	2,1	1,5	3,5	431	452	509	513	2	1,5
	462	512	524	4	4	5	435	455	545	545	3	3
	480	559	577	5	5	15	438	469	602	602	4	4
440	474	506	516	2,1	1,5	3,5	451	469	529	533	2	1,5
	474	508	516	2,1	1,5	3,5	451	469	529	533	2	1,5
	502	545	565,5	4	4	6	455	492	585	585	3	3
	500	590	611	6	6	16	463	488	627	627	5	5

¹⁾ Permissible axial displacement from the normal position of one bearing ring in relation to the other

²⁾ Recommended shaft abutment diameter for axially loaded bearings → [page 562](#)

Single row full complement cylindrical roller bearings
d 460 – 670 mm

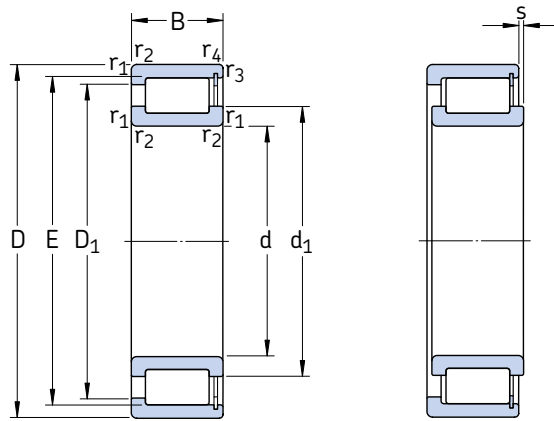

Principal dimensions			Basic load ratings		Fatigue load limit P_u	Speed ratings		Mass	Designation
d	D	B	C	C_0		Reference speed	Limiting speed		
mm			kN		kN	r/min	kg	–	
460	580	56	913	1 960	163	430	530	34,0	NCF 1892 V
	580	72	1 300	3 050	260	430	530	44,0	NCF 2892 V
	620	95	2 050	4 500	390	400	500	83,5	NCF 2992 V
	680	163	3 690	6 950	540	380	480	195	NCF 3092 CV
480	600	56	935	2 040	170	400	500	35,5	NCF 1896 V
	600	72	1 320	3 150	265	400	500	46,0	NCF 2896 V
	650	100	2 290	4 900	405	380	480	98,0	NCF 2996 V
	700	165	3 740	7 200	550	360	450	205	NCF 3096 CV
500	620	56	952	2 120	173	380	480	36,5	NCF 18/500 V
	620	72	1 340	3 350	275	380	480	48,0	NCF 28/500 V
	670	100	2 330	5 000	415	380	450	100	NCF 29/500 V
	720	167	3 800	7 500	570	360	450	215	NCF 30/500 CV
530	650	56	990	2 240	180	360	450	38,5	NCF 18/530 V
	650	72	1 400	3 450	285	360	450	49,5	NCF 28/530 V
	710	106	2 640	6 100	480	340	430	120	NCF 29/530 V
	780	185	5 230	10 600	780	320	400	300	NCF 30/530 V
560	680	56	1 020	2 360	186	340	430	40,5	NCF 18/560 V
	680	72	1 420	3 650	300	340	430	54,0	NCF 28/560 V
	750	112	3 080	6 700	500	320	400	140	NCF 29/560 V
	820	195	5 830	11 800	865	300	380	345	NCF 30/560 V
600	730	60	1 050	2 550	196	320	400	51,5	NCF 18/600 V
	730	78	1 570	4 300	340	320	400	67,5	NCF 28/600 V
	800	118	3 190	7 100	520	300	380	170	NCF 29/600 V
630	780	69	1 250	2 900	232	300	360	72,5	NCF 18/630 V
	780	88	1 870	5 000	390	300	360	92,5	NCF 28/630 V
	850	128	3 740	8 650	610	280	340	205	NCF 29/630 V
670	820	69	1 300	3 150	245	280	340	76,5	NCF 18/670 V
	820	88	1 940	5 300	415	280	340	97,5	NCF 28/670 V
	900	136	3 910	9 000	630	260	320	245	NCF 29/670 V

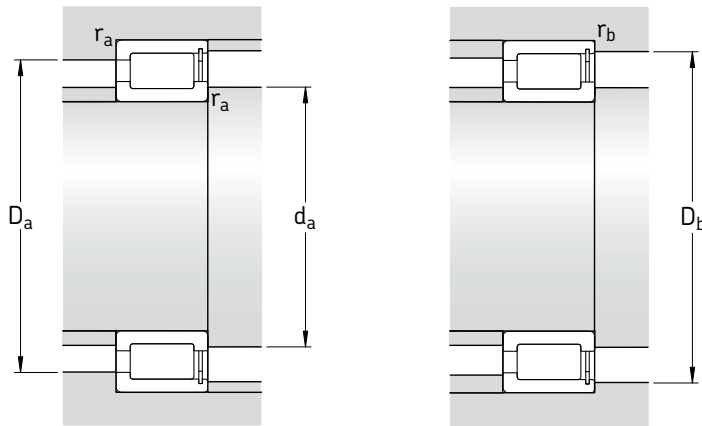

Dimensions

Abutment and fillet dimensions

d	d ₁ ~	D ₁ ~	E	r _{1,2} min	r _{3,4} min	s ¹⁾	d _a min	d _{as} ²⁾	D _a max	D _b max	r _a max	r _b max
mm							mm					
460	501	541	553	3	3	5	473	495	567	567	2,5	2,5
	501	543	553	3	3	5	473	495	567	567	2,5	2,5
	516	558	579	4	4	6	475	506	605	605	3	3
	522	611	635	6	6	16	483	511	657	657	5	5
480	522	561	573,5	3	3	5	493	516	587	587	2,5	2,5
	520	562	573,5	3	3	5	493	515	587	587	2,5	2,5
	538	584	600	5	5	7	498	527	632	632	4	4
	546	628	654	6	6	16	503	532	677	677	5	5
500	542	582	594	3	3	5	513	536	607	607	2,5	2,5
	541	582	594	3	3	2,4	513	536	607	607	2,5	2,5
	553	611	630,9	5	5	7	518	544	652	652	4	4
	565	650	676	6	6	16	523	553	697	697	5	5
530	573	612	624,5	3	3	5	543	567	637	637	2,5	2,5
	572	614	624,5	3	3	5	543	566	637	637	2,5	2,5
	598	661	676	5	5	7	548	589	692	692	4	4
	610	702	732,3	6	6	16	553	595	757	757	5	5
560	603	643	655	3	3	5	573	597	667	667	2,5	2,5
	606	637	655	3	3	4,3	573	599	667	667	2,5	2,5
	628	700	718	5	5	7	578	617	732	732	4	4
	642	738	770	6	6	16	583	626	797	797	5	5
600	644	684	696	3	3	7	613	638	717	717	2,5	2,5
	644	685	696	3	3	6	613	638	717	717	2,5	2,5
	662	726	754	5	5	7	618	652	782	782	4	4
630	681	725	739	4	4	8	645	674	765	765	3	3
	680	728	739	4	4	8	645	674	765	765	3	3
	709	788	807	6	6	8	653	698	827	827	5	5
670	725	769	783	4	4	8	685	718	805	805	3	3
	724	772	783	4	4	8	685	718	805	805	3	3
	748	827	846	6	6	10	693	737	877	877	5	5

¹⁾ Permissible axial displacement from the normal position of one bearing ring in relation to the other

²⁾ Recommended shaft abutment diameter for axially loaded bearings → [page 562](#)

Single row full complement cylindrical roller bearings
d 710– 1 120 mm

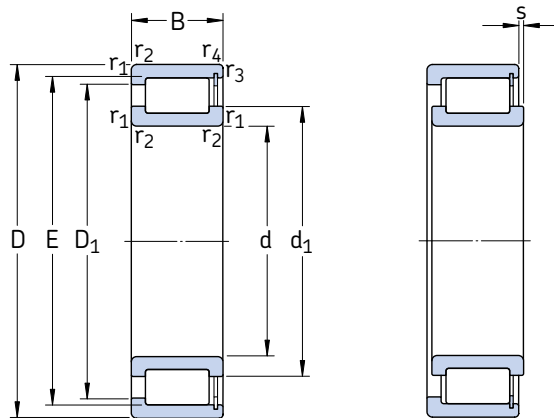

Principal dimensions			Basic load ratings		Fatigue load limit P_u	Speed ratings		Mass	Designation
d	D	B	dynamic C	static C_0		Refer- ence speed	Limiting speed		
mm			kN		kN	r/min		kg	–
710	870	74	1 540	3 750	285	260	320	92,5	NCF 18/710 V
	870	95	2 330	6 300	480	260	320	115	NCF 28/710 V
	950	140	4 290	10 000	695	240	300	275	NCF 29/710 V
750	920	78	1 870	4 500	335	240	300	110	NCF 18/750 V
	920	100	2 640	6 950	520	240	300	140	NCF 28/750 V
	1 000	145	4 460	10 600	710	220	280	315	NCF 29/750 V
800	980	82	1 940	4 800	345	220	280	130	NCF 18/800 V
	980	106	2 750	7 500	550	220	280	165	NCF 28/800 V
	1 060	150	4 950	12 200	800	200	260	360	NCF 29/800 V
850	1 030	82	2 010	5 100	365	200	260	135	NCF 18/850 V
	1 030	106	2 860	8 000	570	200	260	175	NCF 28/850 V
	1 120	155	5 230	12 700	830	190	240	405	NCF 29/850 V
900	1 090	85	2 380	6 000	425	190	240	160	NCF 18/900 V
	1 090	112	3 190	9 150	655	190	240	208	NCF 28/900 V
	1 180	165	5 940	14 600	950	170	220	472	NCF 29/900 V
950	1 150	90	2 420	6 300	440	170	220	185	NCF 18/950 V
	1 150	118	3 410	9 800	655	170	220	240	NCF 28/950 V
	1 250	175	6 600	16 300	1 020	160	200	565	NCF 29/950 V
1 000	1 220	100	2 920	7 500	455	160	200	230	NCF 18/1000 V
	1 220	128	4 130	11 600	720	160	200	310	NCF 28/1000 V
	1 320	185	7 480	18 600	1 160	150	190	680	NCF 29/1000 V
1 120	1 360	106	3 740	9 650	585	130	170	298	NCF 18/1120 V

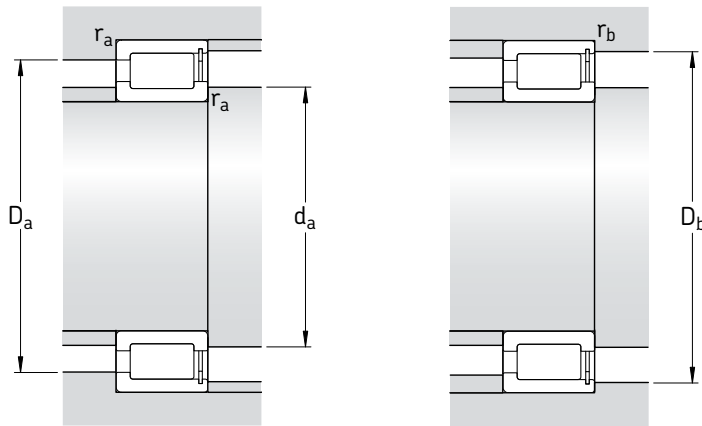

Dimensions

Abutment and fillet dimensions

d	d ₁ ~	D ₁ ~	E	r _{1,2} min	r _{3,4} min	s ¹⁾	d _a min	d _{as} ²⁾	D _a max	D _b max	r _a max	r _b max
mm							mm					
710	767	815	831	4	4	8	725	759	855	855	3	3
	766	818	831	4	4	8	725	759	855	855	3	3
	790	876	896	6	6	10	733	761	927	927	5	5
750	811	863	882	5	5	8	768	802	902	902	4	4
	810	867	878	5	5	8	768	799	902	902	4	4
	832	918	937	6	6	11	773	820	977	977	5	5
800	863	922	936	5	5	9	818	855	962	962	4	4
	863	922	936	5	5	10	818	855	962	962	4	4
	891	981	1 002	6	6	11	823	860	977	977	5	5
850	911	972	985	5	5	9	868	902	1 012	1 012	4	4
	911	972	986	5	5	10	868	903	1 012	1 012	4	4
	943	1 039	1 061	6	6	13	873	914	1 097	1 097	5	5
900	966	1 029	1 044	5	5	9	918	957	1 072	1 072	4	4
	966	1 029	1 044	5	5	10	918	957	1 072	1 072	4	4
	996	1 096	1 120	6	6	13	923	982	1 127	1 127	5	5
950	1 021	1 087	1 103	5	5	10	968	1 012	1 132	1 132	4	4
	1 021	1 087	1 103	5	5	12	968	1 012	1 132	1 132	4	4
	1 048	1 154	1 179	7,5	7,5	14	978	1 033	1 222	1 222	6	6
1 000	1 073	1 148	1 165	6	6	12	1 023	1 063	1 197	1 197	5	5
	1 073	1 148	1 165	6	6	12	1 023	1 063	1 197	1 197	5	5
	1 113	1 226	1 252	7,5	7,5	14	1 028	1 091	1 292	1 292	6	6
1 120	1 206	1 290	1 310	6	6	12	1 143	1 194	1 337	1 337	5	5

¹⁾ Permissible axial displacement from the normal position of one bearing ring in relation to the other

²⁾ Recommended shaft abutment diameter for axially loaded bearings → [page 562](#)



Double row full complement cylindrical roller bearings

Designs	578
NNCL design	578
NNCF design	578
NNC design	578
NNF design	579
Bearing data – general	580
Dimensions	580
Tolerances	580
Internal clearance	580
Axial displacement	580
Misalignment	580
Influence of operating temperature on bearing material	580
Minimum load	581
Dynamic axial load carrying capacity	581
Equivalent dynamic bearing load	582
Equivalent static bearing load	582
Supplementary designations	583
Product tables	584
Double row full complement cylindrical roller bearings	584
Sealed double row full complement cylindrical roller bearings	596

Designs

Double row full complement cylindrical roller bearings incorporate a maximum number of rollers and are therefore suitable for very heavy radial loads. However, they cannot operate at the same high speeds as caged cylindrical roller bearings. SKF double row full complement cylindrical roller bearings are produced as standard in four designs, three open designs and one sealed (→ **fig. 1**). All the bearings are non-separable and have an annular groove and three lubrication holes in the outer ring to facilitate efficient lubrication.

NNCL design

NNCL design bearings (**a**) have an inner ring with three integral flanges and a flangeless outer ring. A retaining ring, inserted in the outer ring between the roller rows, keeps all bearing components together. Axial displacement of the shaft relative to the housing in both directions can be accommodated within the bearing. The bearings are therefore suitable for non-locating bearing positions.

NNCF design

NNCF design bearings (**b**) have three integral flanges on the inner ring and one integral flange on the outer ring enabling the bearing to provide axial location for a shaft in one direction. A retaining ring is inserted in the outer ring at the side opposite the integral flange and serves to hold the bearing together.

NNC design

NNC design bearings (**c**) are equipped with the same inner ring as bearings of the NNCL and NNCF designs. The outer ring is split and held together by retaining elements, which should not be loaded axially. Both parts of the outer ring are identical and carry one integral flange, enabling the bearing to locate the shaft axially in both directions.

Fig. 1

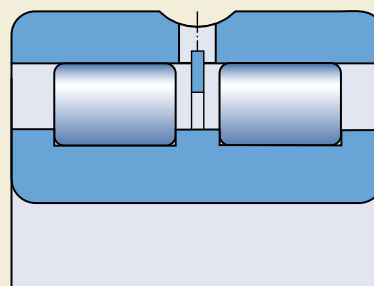

a

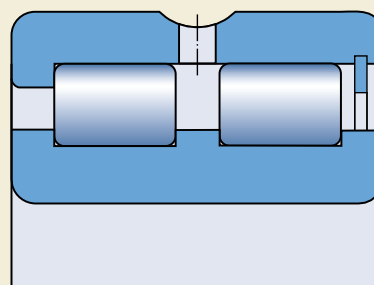

b

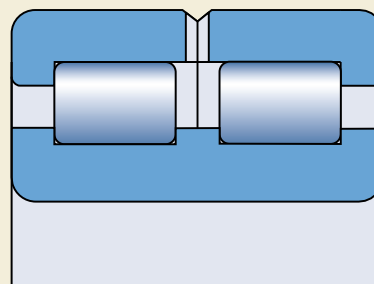

c

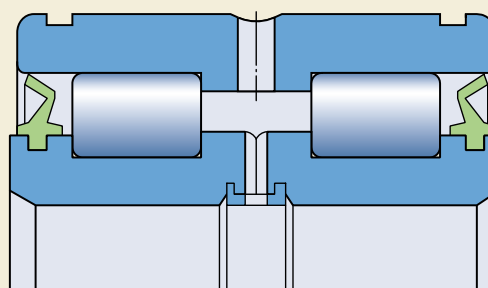

d

NNF design

NNF design bearings (**d**) in the NNF 50 and 3194(00) series are always sealed on both sides and filled with grease. The two-piece inner ring has three integral flanges and is held together by a retaining ring. The outer ring has an integral central flange. The bearings can be used to locate a shaft axially in both directions. Because of the large distance between the two rows of rollers, the bearings are also able to accommodate tilting moments.

The outer ring of an NNF bearing is 1 mm narrower than the inner ring and has two snap ring grooves in the outside diameter. Therefore it is possible to eliminate the need for spacer rings between the inner ring and adjacent components, for example, in rope sheaves (→ **fig. 2**).

The bearings have contact seals made of polyurethane (AU) on both sides. The seals are retained on the inner ring shoulders, to provide efficient sealing at this position. The outer sealing lip exerts a slight pressure on the outer ring raceway.

The bearings are filled with grease with a lithium thickener with diester base oil, which has good rust inhibiting properties. The base oil viscosity is 15 mm²/s at 40 °C and 3,7 mm²/s at 100 °C. The grease is suitable for temperatures between -55 and +110 °C. However, the permissible temperature range is limited by the seal material, from -40 to +80 °C.

Under certain conditions, sealed NNF design bearings are maintenance-free, but if they operate in a moist or contaminated environment, or if speeds are moderate to high, they must be relubricated. This can be done through the inner as well as the outer ring.

If bearings with one or no seals are required, the seals may be removed easily with a screwdriver. For applications where oil lubrication is to be used, the bearings can be delivered without seals and grease if economic quantities are involved. Otherwise the seals should be removed and the bearings washed before use. If oil lubrication is used, the limiting speed quoted in the product tables can be increased by approximately 30 %.

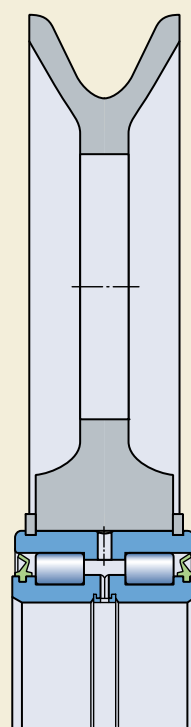

Bearing data – general

Dimensions

The boundary dimensions of SKF double row full complement cylindrical roller bearings are in accordance with ISO 15:1998, except for bearings in the NNF 50 and 3194(00) series. The outer rings of NNF bearings are 1 mm narrower than specified for the ISO Dimension Series 50. The dimensions of series 3194(00) bearings have been dictated by practical application requirements and are not covered by any international or national standard.

Tolerances

Double row full complement cylindrical roller bearings are manufactured to Normal tolerances as standard. The tolerances are in accordance with ISO 492:2002 and can be found in **table 3** on **page 125**.

Internal clearance

Double row full complement cylindrical roller bearings are manufactured with Normal radial internal clearance as standard. Bearings with the larger C3 or smaller C2 radial internal clearance can be supplied on request.

The clearance limits are in accordance with ISO 5753:1991 and can be found in **table 1** on **page 513**. The clearance limits apply to unmounted bearings under zero measuring load.

The axial internal clearance of NNC and NNF design bearings, which can axially locate the shaft in both directions, is 0,1 to 0,2 mm for all sizes.

Axial displacement

NNCL and NNCF design bearings can accommodate axial displacement of the shaft with respect to the housing as a result of thermal expansion of the shaft within certain limits (→ **fig. 3**). As the axial displacement is accommodated within the bearing and not between the ring and shaft or housing bore, there is practically no additional friction when the bearing rotates. Values for the permissible axial displacement “s” from the normal position of one bearing ring in relation to the other are provided in the product table.

Misalignment

Any angular misalignment of the outer ring relative to the inner ring of double row full complement cylindrical roller bearings produces moment loads in the bearing. The resulting increased bearing load shortens bearing service life.

Influence of operating temperature on bearing material

SKF double row full complement cylindrical roller bearings undergo a special heat treatment. They can be used at temperatures of up to +150 °C.

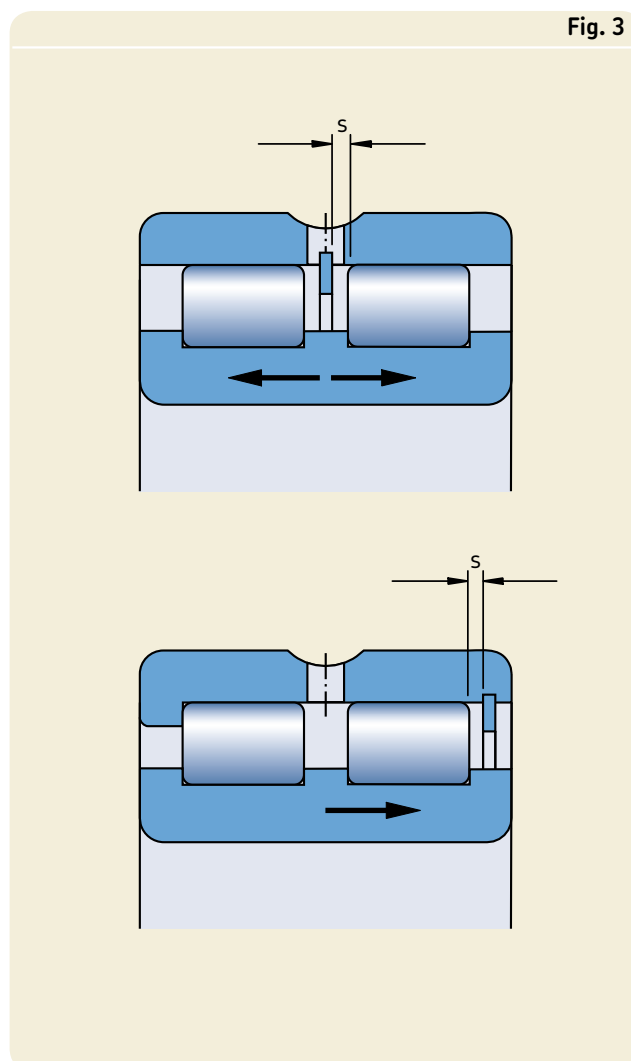

Minimum load

In order to provide satisfactory operation, double row full complement cylindrical roller bearings, like all ball and roller bearings, must always be subjected to a given minimum load, particularly if they are to operate at relatively high speeds ($n > 0,5$ times the reference speed) or are subjected to high accelerations or rapid changes in the direction of load. Under such conditions, the inertia forces of the rollers and the friction in the lubricant, can have a detrimental effect on the rolling conditions in the bearing arrangement and may cause damaging sliding movements to occur between the rollers and raceways.

The requisite minimum load to be applied to double row full complement cylindrical roller bearings can be estimated using

$$F_{rm} = k_r \left(6 + \frac{4n}{n_r} \right) \left(\frac{d_m}{100} \right)^2$$

where

F_{rm} = minimum radial load, kN

k_r = minimum load factor

0,2 for bearing series 48

0,25 for bearing series 49

0,4 for bearing series NNF 50
and 3194(00)

0,5 for bearing series NNCF 50

n = rotational speed, r/min

n_r = speed rating according to the product tables, r/min

– for open bearings use reference speed

– for sealed bearings use

1,3 × limiting speed

d_m = bearing mean diameter

= 0,5 (d + D), mm

When starting up at low temperatures or when the lubricant is highly viscous, even greater minimum loads may be required. The weight of the components supported by the bearing, together with external forces, generally exceeds the requisite minimum load. If this is not the case, the double row full complement cylindrical roller bearing must be subjected to an additional radial load.

Dynamic axial load carrying capacity

Double row full complement cylindrical roller bearings with flanges on both the inner and outer rings can support axial loads in addition to radial loads. Their axial load carrying capacity is primarily determined by the ability of the sliding surfaces of the roller end/flange contact to support loads. Factors having the greatest effect on this ability are the lubrication, operating temperature and heat dissipation from the bearing.

Assuming the conditions cited below, the permissible axial load can be calculated with sufficient accuracy from

$$F_{ap} = \frac{k_1 C_0 10^4}{n (d + D)} - k_2 F_r$$

where

F_{ap} = permissible axial load, kN

C_0 = basic static load rating, kN

F_r = actual radial bearing load, kN

n = rotational speed, r/min

d = bearing bore diameter, mm

D = bearing outside diameter, mm

k_1 = a factor

0,35 for oil lubrication

0,2 for grease lubrication

k_2 = a factor

0,1 for oil lubrication

0,06 for grease lubrication

The above equation is based on conditions that are considered typical for normal bearing operation, i.e.

- a difference of 60 °C between the bearing operating temperature and the ambient temperature
- a specific heat loss from the bearing of 0,5 mW/mm² °C; with reference to the bearing outside diameter surface ($\pi D B$)
- a viscosity ratio $\kappa \geq 2$.

For grease lubrication the viscosity of the base oil in the grease may be used. If κ is less than 2, the friction will increase and there will be more wear. These effects can be reduced at low speeds, for example, by using oils with AW (anti-wear) and/or EP (extreme pressure) additives.

Where axial loads act for longer periods and the bearings are grease lubricated, it is advis-

Double row full complement cylindrical roller bearings

able to use a grease that has good oil bleeding properties at the operating temperature (> 3 % according to DIN 51 817). Frequent relubrication is also recommended.

The values of the permissible load F_{ap} obtained from the heat balance equation are valid for a continuously acting constant axial load and adequate lubricant supply to the roller end/flange contacts. Where axial loads act only for short periods, the values may be multiplied by a factor of 2, or for shock loads by a factor of 3, provided the limits given in the following with regard to flange strength are not exceeded.

To avoid any risk of flange breakage, the constantly acting axial load applied to the bearings should never exceed

$$F_{a \max} = 0,0023 D^{1,7}$$

When acting only occasionally and for brief periods, the axial load applied to the bearings should never exceed

$$F_{a \max} = 0,007 D^{1,7}$$

where

$F_{a \max}$ = maximum constantly or occasionally acting axial load, kN

D = bearing outside diameter, mm

To obtain an even flange load and provide sufficient running accuracy of the shaft when double row full complement cylindrical roller bearings are subjected to heavy axial loads, axial runout and the size of the abutment surfaces

of adjacent components become particularly important.

If shaft deflection occurs together with an axial load, the inner ring flange should only be supported to half its height (→ **fig. 4**) so that it is not subjected to damaging alternating stresses. The recommended shaft abutment diameter d_{as} can be obtained from the product tables.

Where misalignment between the inner and outer rings exceeds 1 minute of arc, the action of the load on the flange changes considerably. As a result, the safety factors implicit in the guideline values may not be adequate. In these cases, contact the SKF application engineering service.

Equivalent dynamic bearing load

For non-locating bearings

$$P = F_r$$

If double row full complement cylindrical roller bearings with flanges on both inner and outer rings are used to locate a shaft in one or both directions, the equivalent dynamic bearing load should be calculated using

$$P = F_r \quad \text{when } F_a/F_r \leq 0,15$$

$$P = 0,92 F_r + 0,4 F_a \quad \text{when } F_a/F_r > 0,15$$

Since axially loaded double row full complement cylindrical roller bearings only operate satisfactorily when they are subjected to a simultaneously acting radial load, the ratio F_a/F_r should not exceed 0,25.

Equivalent static bearing load

$$P_0 = F_r$$

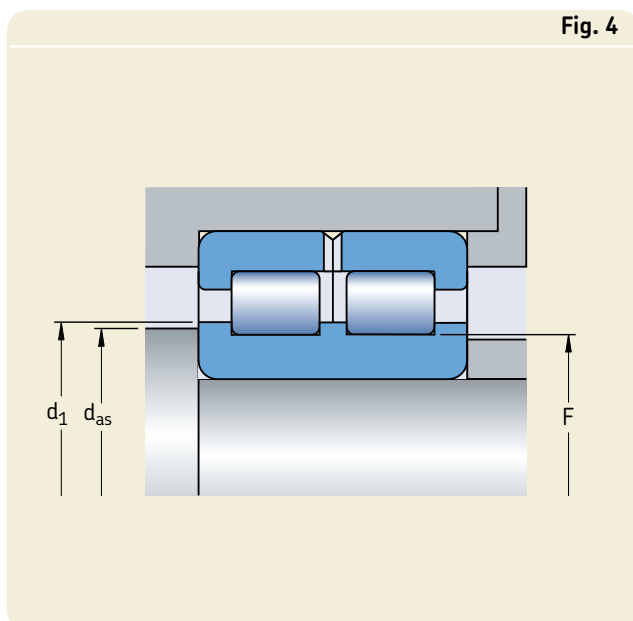

Supplementary designations

The designation suffixes used to identify certain features of SKF double row full complement cylindrical roller bearings are explained in the following.

- ADA** Modified snap ring grooves in the outer ring; two-piece inner ring held together by a retaining ring
- CV** Modified internal design, full complement roller set
- C2** Radial internal clearance smaller than Normal
- C3** Radial internal clearance greater than Normal
- DA** Modified snap ring grooves in the outer ring; two-piece inner ring held together by a retaining ring
- L4B** Bearing rings and rolling elements with special surface coating
- L5B** Rolling elements with special surface coating
- V** Full complement of rollers (without cage)
- 2LS** Contact seal of polyurethane (AU) on both sides of the bearing

Double row full complement cylindrical roller bearings d 20 – 85 mm

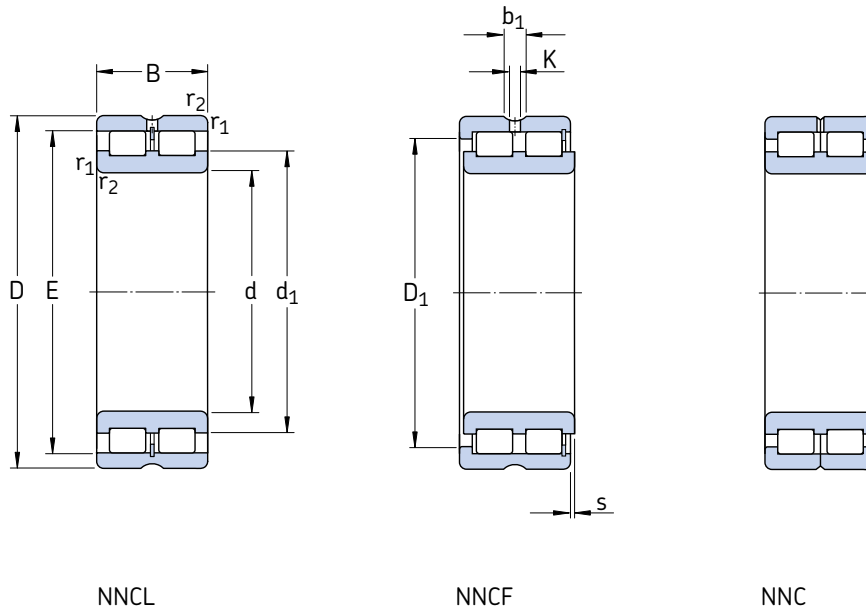

Principal dimensions			Basic load ratings		Fatigue load limit P_u	Speed ratings		Mass	Designation
d	D	B	dynamic C	static C_0		Refer- ence speed	Limiting speed		
mm			kN		kN	r/min		kg	–
20	42	30	52,3	57	6,2	8 500	10 000	0,20	NNCF 5004 CV
25	47	30	59,4	71	7,65	7 000	9 000	0,23	NNCF 5005 CV
30	55	34	73,7	88	10	6 000	7 500	0,35	NNCF 5006 CV
35	62	36	89,7	112	12,9	5 300	6 700	0,46	NNCF 5007 CV
40	68	38	106	140	16,3	4 800	6 000	0,56	NNCF 5008 CV
45	75	40	112	156	18,3	4 300	5 300	0,71	NNCF 5009 CV
50	80	40	142	196	23,6	4 000	5 000	0,76	NNCF 5010 CV
55	90	46	190	280	34,5	3 400	4 300	1,16	NNCF 5011 CV
60	85	25	78,1	137	14,3	3 600	4 500	0,48	NNCF 4912 CV
	85	25	78,1	137	14,3	3 600	4 500	0,49	NNC 4912 CV
	85	25	78,1	137	14,3	3 600	4 500	0,47	NNCL 4912 CV
	95	46	198	300	36,5	3 400	4 000	1,24	NNCF 5012 CV
65	100	46	209	325	40	3 000	3 800	1,32	NNCF 5013 CV
70	100	30	114	193	22,4	3 000	3 800	0,77	NNCF 4914 CV
	100	30	114	193	22,4	3 000	3 800	0,78	NNC 4914 CV
	100	30	114	193	22,4	3 000	3 800	0,75	NNCL 4914 CV
	110	54	238	345	45	2 800	3 600	1,85	NNCF 5014 CV
75	115	54	251	380	49	2 600	3 200	1,93	NNCF 5015 CV
80	110	30	121	216	25	2 600	3 400	0,87	NNCF 4916 CV
	110	30	121	216	25	2 800	3 400	0,88	NNC 4916 CV
	110	30	121	216	25	2 600	3 400	0,85	NNCL 4916 CV
	125	60	308	455	58,5	2 400	3 000	2,59	NNCF 5016 CV
85	130	60	314	475	60	2 400	3 000	2,72	NNCF 5017 CV

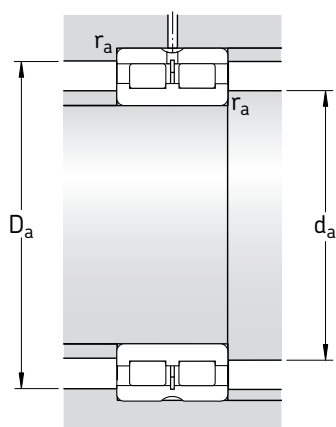

Dimensions								Abutment and fillet dimensions			
d	d_1 ~	D_1 ~	E	b_1	K	$r_{1,2}$ min	$s^{1)}$	d_a min	$d_{as}^{2)}$	D_a max	r_a max
mm								mm			
20	28,4	33,2	36,81	4,5	3	0,6	1	23,2	26,6	38,8	0,6
25	34,5	38,9	42,51	4,5	3	0,6	1	28,2	28,2	43,8	0,6
30	40	45,3	49,6	4,5	3	1	1,5	34,6	34,6	50,4	1
35	44,9	51,3	55,52	4,5	3	1	1,5	39,6	39,6	57,4	1
40	50,5	57,2	61,74	4,5	3	1	1,5	44,6	44,6	63,4	1
45	55,3	62,5	66,85	4,5	3	1	1,5	49,6	49,6	70,4	1
50	59,1	67,6	72,23	4,5	3	1	1,5	54,6	54,6	75,4	1
55	68,5	78,7	83,54	4,5	3,5	1,1	1,5	61	61	84	1
60	70,5	73,5	77,51	4,5	3,5	1	1	64,6	68,5	80,4	1
	70,5	73,5	77,51	4,5	3,5	1	-	64,6	68,5	80,4	1
	70,5	-	77,51	4,5	3,5	1	1	64,6	-	80,4	1
	71,7	81,9	86,74	4,5	3,5	1,1	1,5	66	69,2	89	1
65	78,1	88,3	93,09	4,5	3,5	1,1	1,5	71	71	94	1
70	83	87	91,87	4,5	3,5	1	1	74,6	80,4	95,4	1
	83	87	91,87	4,5	3,5	1	-	74,6	80,4	95,4	1
	83	-	91,87	4,5	3,5	1	1	74,6	-	95,4	1
	81,5	95	100,28	5	3,5	1,1	3	76	78,9	104	1
75	89	103	107,9	5	3,5	1,1	3	81	81	109	1
80	91,4	96	97,78	5	3,5	1	1	84,6	89,4	105,4	1
	92	96	100,78	5	3,5	1	-	84,6	89,4	105,4	1
	92	-	100,78	5	3,5	1	1	84,6	-	105,4	1
	95	111	116,99	5	3,5	1,1	3,5	86	92	119	1
85	99	117	121,44	5	3,5	1,1	3,5	91	91	124	1

1) Permissible axial displacement from the normal position of one bearing ring in relation to the other

2) Recommended shaft abutment diameter for axially loaded bearings → page 582

Double row full complement cylindrical roller bearings
d 90 – 150 mm

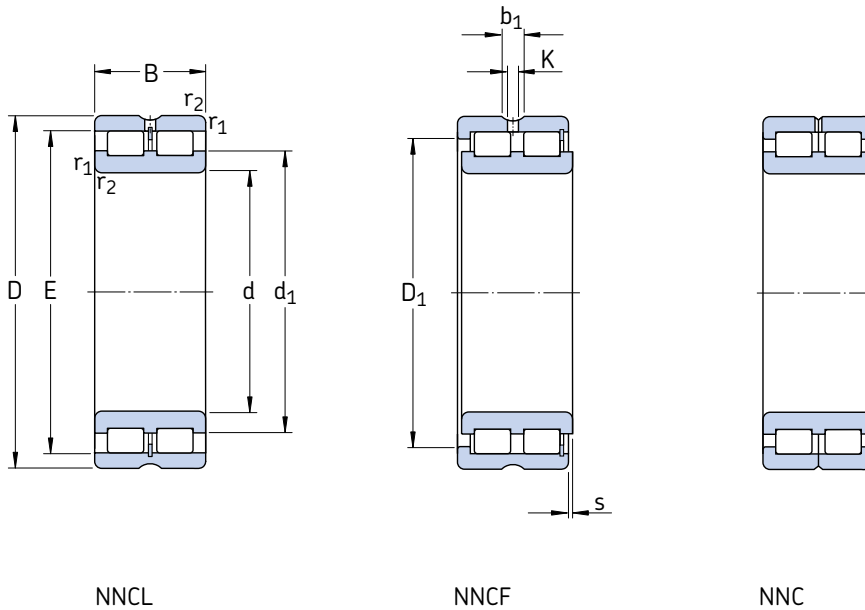

Principal dimensions			Basic load ratings		Fatigue load limit P_u	Speed ratings		Mass	Designation
d	D	B	dynamic C	static C_0		Refer- ence speed	Limiting speed		
mm			kN		kN	r/min		kg	–
90	125	35	161	300	35,5	2 400	3 000	1,33	NNCF 4918 CV
	125	35	161	300	35,5	2 400	3 000	1,35	NNC 4918 CV
	125	35	161	300	35,5	2 400	3 000	1,30	NNCL 4918 CV
	140	67	369	560	69,5	2 200	2 800	3,62	NNCF 5018 CV
100	140	40	209	400	46,5	2 000	2 600	1,93	NNCF 4920 CV
	140	40	209	400	46,5	2 000	2 600	1,95	NNC 4920 CV
	140	40	209	400	46,5	2 000	2 600	1,90	NNCL 4920 CV
	150	67	391	620	75	2 000	2 600	3,94	NNCF 5020 CV
110	150	40	220	430	49	1 900	2 400	2,12	NNCF 4922 CV
	150	40	220	430	49	1 900	2 400	2,15	NNC 4922 CV
	150	40	220	430	49	1 900	2 400	2,10	NNCL 4922 CV
	170	80	512	800	95	1 800	2 200	6,32	NNCF 5022 CV
120	165	45	242	480	53	1 700	2 200	2,90	NNCF 4924 CV
	165	45	242	480	53	1 700	2 200	2,95	NNC 4924 CV
	165	45	242	480	53	1 700	2 200	2,85	NNCL 4924 CV
	180	80	539	880	104	1 700	2 000	6,77	NNCF 5024 CV
130	180	50	275	530	60	1 600	2 000	3,88	NNCF 4926 CV
	180	50	275	530	60	1 600	2 000	3,95	NNC 4926 CV
	180	50	275	530	60	1 600	2 000	3,80	NNCL 4926 CV
	200	95	765	1 250	143	1 500	1 900	10,2	NNCF 5026 CV
140	190	50	286	570	63	1 500	1 900	4,15	NNCF 4928 CV
	190	50	286	570	63	1 500	1 900	4,20	NNC 4928 CV
	190	50	286	570	63	1 500	1 900	4,10	NNCL 4928 CV
	210	95	809	1 370	156	1 400	1 800	11,1	NNCF 5028 CV
150	190	40	255	585	60	1 500	1 800	2,80	NNCF 4830 CV
	190	40	255	585	60	1 500	1 800	2,90	NNC 4830 CV
	190	40	255	585	60	1 500	1 800	2,70	NNCL 4830 CV
	210	60	429	830	91,5	1 400	1 700	6,55	NNCF 4930 CV
	210	60	429	830	91,5	1 400	1 700	6,65	NNC 4930 CV
	210	60	429	830	91,5	1 400	1 700	6,45	NNCL 4930 CV
	225	100	842	1 430	160	1 300	1 700	13,3	NNCF 5030 CV

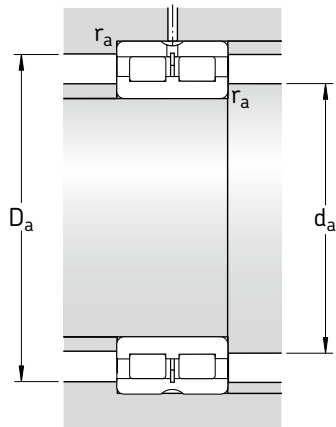

Dimensions								Abutment and fillet dimensions			
d	d ₁ ~	D ₁ ~	E	b ₁	K	r _{1,2} min	s ¹⁾	d _a min	d _{as} ²⁾	D _a max	r _a max
mm								mm			
90	103	111	113,2	5	3,5	1,1	1,5	96	100	119	1
	103	110	115,2	5	3,5	1,1	-	96	101	119	1
	103	-	115,2	5	3,5	1,1	1,5	96	-	119	1
	106	124	130,11	5	3,5	1,5	4	97	103	133	1,5
100	116	125	129,6	5	3,5	1,1	2	106	114	134	1
	116	125	129,6	5	3,5	1,1	-	106	114	134	1
	116	-	129,6	5	3,5	1,1	2	106	-	134	1
	115	134	139,65	6	3,5	1,5	4	107	112	143	1,5
110	124	134	138,2	6	3,5	1,1	2	116	122	144	1
	125	134	138,2	6	3,5	1,1	-	116	123	144	1
	125	-	138,2	6	3,5	1,1	2	116	-	144	1
	127	149	156,13	6	3,5	2	5	120	124	160	2
120	138	149	153,55	6	3,5	1,1	3	126	136	159	1
	139	148	153,55	6	3,5	1,1	-	126	136	159	1
	139	-	153,55	6	3,5	1,1	3	126	-	159	1
	138	161	167,58	6	3,5	2	5	130	135	170	2
130	148	160	165,4	6	3,5	1,5	4	137	146	173	1,5
	149	160	165,4	6	3,5	1,5	-	137	146	173	1,5
	149	-	165,4	6	3,5	1,5	4	137	-	173	1,5
	149	175	183,81	7	4	2	5	140	140	190	2
140	159	171	175,9	6	3,5	1,5	4	147	156	183	1,5
	160	170	175,9	6	3,5	1,5	-	147	157	183	1,5
	160	-	175,9	6	3,5	1,5	4	147	-	183	1,5
	163	189	197,82	7	4	2	5	150	150	200	2
150	166	173	178,3	7	4	1,1	2	156	163	184	1
	166	173	178,3	7	4	1,1	-	156	163	184	1
	166	-	178,3	7	4	1,1	2	156	-	184	1
	170	187	192,77	7	4	2	4	160	167	200	2
	171	187	192,77	7	4	2	-	160	168	200	2
	171	-	192,77	7	4	2	4	160	-	200	2
	170	198	206,8	7	4	2	6	160	160	215	2

¹⁾ Permissible axial displacement from the normal position of one bearing ring in relation to the other

²⁾ Recommended shaft abutment diameter for axially loaded bearings → page 582

Double row full complement cylindrical roller bearings
d 160 – 190 mm

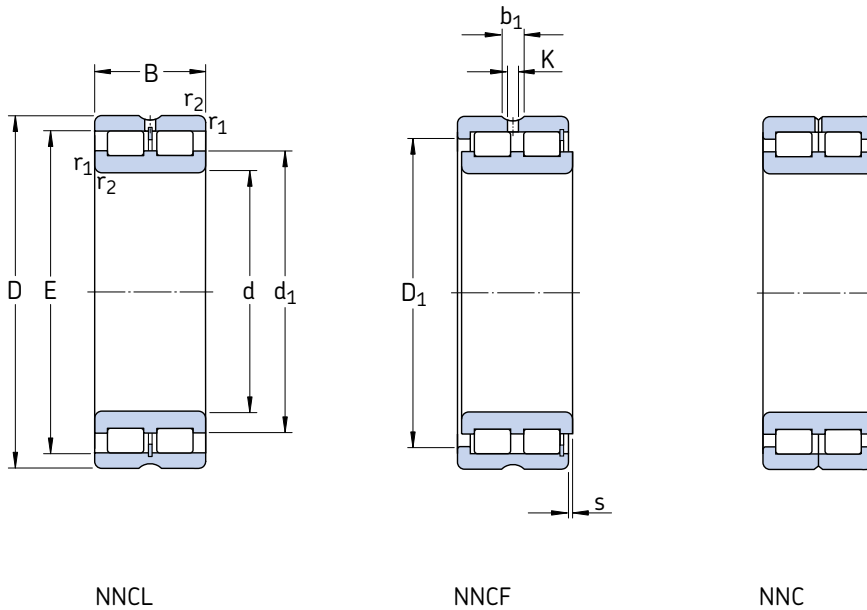

Principal dimensions			Basic load ratings		Fatigue load limit P_u	Speed ratings		Mass	Designation
d	D	B	dynamic C	static C_0		Refer- ence speed	Limiting speed		
mm			kN		kN	r/min		kg	–
160	200	40	260	610	62	1 400	1 700	3,00	NNCF 4832 CV
	200	40	260	610	62	1 400	1 700	3,10	NNC 4832 CV
	200	40	260	610	62	1 400	1 700	2,90	NNCL 4832 CV
	220	60	446	915	96,5	1 300	1 600	6,90	NNCF 4932 CV
	220	60	446	915	96,5	1 300	1 600	7,00	NNC 4932 CV
	220	60	446	915	96,5	1 300	1 600	6,80	NNCL 4932 CV
170	240	109	952	1 600	180	1 200	1 500	16,2	NNCF 5032 CV
	215	45	286	655	65,5	1 300	1 600	4,00	NNCF 4834 CV
	215	45	286	655	65,5	1 300	1 600	4,10	NNC 4834 CV
	215	45	286	655	65,5	1 300	1 600	3,90	NNCL 4834 CV
	230	60	457	950	100	1 200	1 500	7,20	NNCF 4934 CV
	230	60	457	950	100	1 200	1 500	7,35	NNC 4934 CV
180	230	60	457	950	100	1 200	1 500	7,10	NNCL 4934 CV
	260	122	1 230	2 120	236	1 100	1 400	23,0	NNCF 5034 CV
	225	45	297	695	69,5	1 200	1 500	4,20	NNCF 4836 CV
	225	45	297	695	69,5	1 200	1 500	4,30	NNC 4836 CV
	225	45	297	695	69,5	1 200	1 500	4,10	NNCL 4836 CV
	250	69	594	1 220	127	1 100	1 400	10,7	NNCF 4936 CV
190	250	69	594	1 220	127	1 100	1 400	10,8	NNC 4936 CV
	250	69	594	1 220	127	1 100	1 400	10,5	NNCL 4936 CV
	280	136	1 420	2 500	270	1 100	1 300	30,5	NNCF 5036 CV
	240	50	330	750	76,5	1 100	1 400	5,50	NNCF 4838 CV
	240	50	330	750	76,5	1 100	1 400	5,65	NNC 4838 CV
	240	50	330	750	76,5	1 100	1 400	5,30	NNCL 4838 CV
190	260	69	605	1 290	132	1 100	1 400	11,1	NNCF 4938 CV
	260	69	605	1 290	132	1 100	1 400	11,2	NNC 4938 CV
	260	69	605	1 290	132	1 100	1 400	10,9	NNCL 4938 CV
	290	136	1 470	2 600	280	1 000	1 300	31,5	NNCF 5038 CV

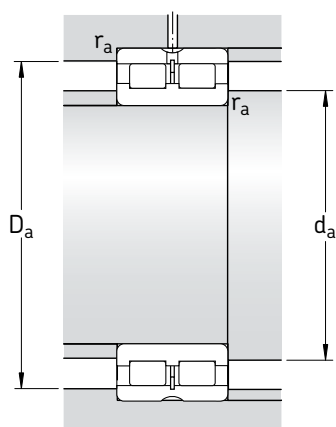

Dimensions								Abutment and fillet dimensions			
d	d ₁ ~	D ₁ ~	E	b ₁	K	r _{1,2} min	s ¹⁾	d _a min	d _{as} ²⁾	D _a max	r _a max
mm								mm			
160	174	182	186,9	7	4	1,1	2	166	171	194	1
	174	182	186,9	7	4	1,1	–	166	171	194	1
	174	–	186,9	7	4	1,1	2	166	–	194	1
	184	200	206,16	7	4	2	4	170	181	210	2
	185	200	206,16	7	4	2	–	170	182	210	2
	185	–	206,16	7	4	2	4	170	–	210	2
	184	216	224,8	7	4	2,1	6	171	171	229	2
170	187	196	201,3	7	4	1,1	3	176	184	209	1
	187	196	201,3	7	4	1,1	–	176	184	209	1
	187	–	201,3	7	4	1,1	3	176	–	209	1
	193	209	215,08	7	4	2	4	180	190	220	2
	194	209	215,08	7	4	2	–	180	191	220	2
	194	–	215,08	7	4	2	4	180	–	220	2
	198	232	243	7	4	2,1	6	181	181	249	2
180	200	209	214,1	7	4	1,1	3	186	197	219	1
	200	209	214,1	7	4	1,1	–	186	197	219	1
	200	–	214,1	7	4	1,1	3	186	–	219	1
	205	224	230,5	7	4	2	4	190	202	240	2
	206	224	230,5	7	4	2	–	190	202	240	2
	206	–	230,5	7	4	2	4	190	–	240	2
	212	249	260,5	8	4	2,1	8	191	206	269	2
190	209	219	225	7	4	1,5	4	197	206	233	1,5
	209	219	225	7	4	1,5	–	197	206	233	1,5
	209	–	225	7	4	1,5	4	197	–	233	1,5
	215	234	240,7	7	4	2	4	200	212	250	2
	216	233	240,7	7	4	2	–	200	212	250	2
	216	–	240,7	7	4	2	4	200	–	250	2
	222	258	270	8	4	2,1	8	201	201	279	2

¹⁾ Permissible axial displacement from the normal position of one bearing ring in relation to the other

²⁾ Recommended shaft abutment diameter for axially loaded bearings → page 582

Double row full complement cylindrical roller bearings
d 200 – 260 mm

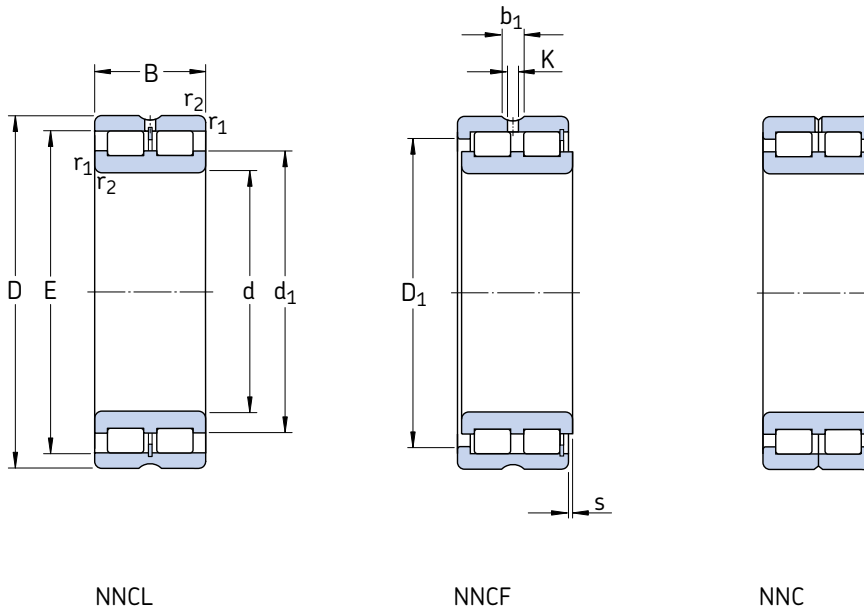

Principal dimensions			Basic load ratings		Fatigue load limit P_u	Speed ratings		Mass	Designation
d	D	B	dynamic C	static C_0		Refer- ence speed	Limiting speed		
mm			kN		kN	r/min		kg	–
200	250	50	336	800	80	1 100	1 400	5,80	NNCF 4840 CV
	250	50	336	800	80	1 100	1 400	5,90	NNC 4840 CV
	250	50	336	800	80	1 100	1 400	5,70	NNCL 4840 CV
	280	80	704	1 500	153	1 000	1 300	15,6	NNCF 4940 CV
	280	80	704	1 500	153	1 000	1 300	15,8	NNC 4940 CV
	280	80	704	1 500	153	1 000	1 300	15,3	NNCL 4940 CV
220	310	150	1 680	3 050	320	950	1 200	41,0	NNCF 5040 CV
	270	50	352	865	85	1 000	1 200	6,30	NNCF 4844 CV
	270	50	352	865	85	1 000	1 200	6,40	NNC 4844 CV
	270	50	352	865	85	1 000	1 200	6,20	NNCL 4844 CV
	300	80	737	1 600	160	950	1 200	17,0	NNCF 4944 CV
	300	80	737	1 600	160	950	1 200	17,2	NNC 4944 CV
240	300	80	737	1 600	160	950	1 200	16,8	NNCL 4944 CV
	340	160	2 010	3 600	375	850	1 100	52,5	NNCF 5044 CV
	300	60	539	1 290	125	900	1 100	9,90	NNCF 4848 CV
	300	60	539	1 290	125	900	1 100	10,0	NNC 4848 CV
	300	60	539	1 290	125	900	1 100	9,80	NNCL 4848 CV
	320	80	781	1 760	173	850	1 100	18,3	NNCF 4948 CV
260	320	80	781	1 760	173	850	1 100	18,5	NNC 4948 CV
	320	80	781	1 760	173	850	1 100	17,9	NNCL 4948 CV
	360	160	2 120	3 900	400	800	1 000	56,0	NNCF 5048 CV
	320	60	561	1 400	132	800	1 000	10,8	NNCF 4852 CV
	320	60	561	1 400	132	800	1 000	11,0	NNC 4852 CV
	320	60	561	1 400	132	800	1 000	10,6	NNCL 4852 CV
	360	100	1 170	2 550	245	750	950	31,6	NNCF 4952 CV
	360	100	1 170	2 550	245	750	950	32,0	NNC 4952 CV
	360	100	1 170	2 550	245	750	950	31,2	NNCL 4952 CV
	400	190	2 860	5 100	500	700	900	85,5	NNCF 5052 CV

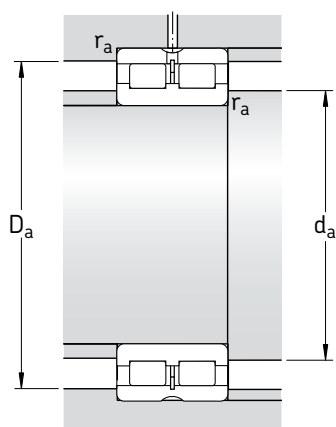

Dimensions								Abutment and fillet dimensions				
d	d ₁	D ₁	E	b ₁	K	r _{1,2} min	s ¹⁾	d _a min	d _{as} ²⁾	D _a max	r _a max	
mm								mm				
200	220	230	235,5	7	4	1,5	4	207	217	243	1,5	
	220	230	235,5	7	4	1,5	–	207	217	243	1,5	
	220	–	235,5	7	4	1,5	4	207	–	243	1,5	
	230	252	259,3	8	4	2,1	5	211	227	269	2	
	231	252	259,34	8	4	2,1	–	211	227	269	2	
	231	–	259,34	8	4	2,1	5	211	–	269	2	
	236	276	288	8	4	2,1	9	211	230	299	2	
	220	241	251	256,5	7	4	1,5	4	227	238	263	1,5
	241	251	256,5	7	4	1,5	–	227	238	263	1,5	
	241	–	256,5	7	4	1,5	4	227	–	263	1,5	
	247	269	276,52	8	4	2,1	5	231	244	289	2	
	248	269	276,52	8	4	2,1	–	231	244	289	2	
	248	–	276,52	8	4	2,1	5	231	–	289	2	
	255	300	312,2	8	6	3	9	235	248	325	2,5	
240	261	275	281,9	8	4	2	4	250	257	290	2	
	261	275	281,9	8	4	2	–	250	257	290	2	
	261	–	281,9	8	4	2	4	250	–	290	2	
	270	292	299,46	8	4	2,1	5	251	267	309	2	
	271	291	299,1	8	4	2,1	–	251	267	309	2	
	271	–	299,46	8	4	2,1	5	251	–	309	2	
	278	322	335,6	9,4	5	3	9	255	271	345	2,5	
	260	283	297	304,2	8	4	2	4	270	280	310	2
	283	297	304,2	8	4	2	–	270	280	310	2	
	283	–	304,2	8	4	2	4	270	–	310	2	
	294	322	331,33	9,4	5	2,1	6	271	290	349	2	
	295	321	331,33	9,4	5	2,1	–	271	290	349	2	
	295	–	331,33	9,4	5	2,1	6	271	–	349	2	
	304	357	373,5	9,4	5	4	10	278	297	382	3	

¹⁾ Permissible axial displacement from the normal position of one bearing ring in relation to the other

²⁾ Recommended shaft abutment diameter for axially loaded bearings → page 582

Double row full complement cylindrical roller bearings
d 280 – 340 mm

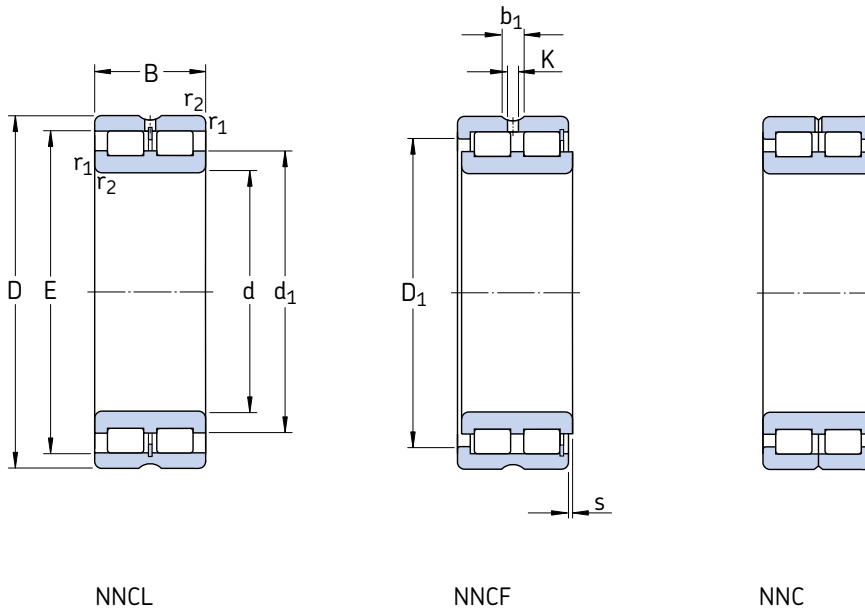

Principal dimensions			Basic load ratings		Fatigue load limit P_u	Speed ratings		Mass	Designation
d	D	B	dynamic C	static C_0		Refer- ence speed	Limiting speed		
mm			kN		kN	r/min		kg	–
280	350	69	737	1 860	173	750	950	15,8	NNCF 4856 CV
	350	69	737	1 860	173	750	950	16,0	NNC 4856 CV
	350	69	737	1 860	173	750	950	15,6	NNCL 4856 CV
	380	100	1 210	2 700	255	700	900	33,5	NNCF 4956 CV
	380	100	1 210	2 700	255	700	900	34,0	NNC 4956 CV
	380	100	1 210	2 700	255	700	900	33,0	NNCL 4956 CV
300	420	190	2 920	5 300	520	670	850	90,5	NNCF 5056 CV
	380	80	858	2 120	196	700	850	22,5	NNCF 4860 CV
		80	858	2 120	196	700	850	23,0	NNC 4860 CV
		80	858	2 120	196	700	850	22,0	NNCL 4860 CV
	420	118	1 680	3 750	355	670	800	52,5	NNCF 4960 CV
	420	118	1 680	3 750	355	670	800	53,0	NNC 4960 CV
420	118	1 680	3 750	355	670	800	52,0	NNCL 4960 CV	
320	460	218	3 250	6 550	600	600	750	130	NNCF 5060 CV
	400	80	897	2 280	208	630	800	23,5	NNCF 4864 CV
		80	897	2 280	208	630	800	24,0	NNC 4864 CV
		80	897	2 280	208	630	800	23,0	NNCL 4864 CV
	440	118	1 760	4 050	375	600	750	55,5	NNCF 4964 CV
	440	118	1 760	4 050	375	600	750	56,0	NNC 4964 CV
440	118	1 760	4 050	375	600	750	55,0	NNCL 4964 CV	
340	480	218	3 690	6 950	620	560	700	135	NNCF 5064 CV
	420	80	913	2 400	216	600	750	25,0	NNCF 4868 CV
		80	913	2 400	216	600	750	25,5	NNC 4868 CV
		80	913	2 400	216	600	750	25,3	NNCL 4868 CV
	460	118	1 790	4 250	390	560	700	58,5	NNCF 4968 CV
	460	118	1 790	4 250	390	560	700	59,0	NNC 4968 CV
460	118	1 790	4 250	390	560	700	57,8	NNCL 4968 CV	
520	243	4 400	8 300	710	530	670	185	NNCF 5068 CV	

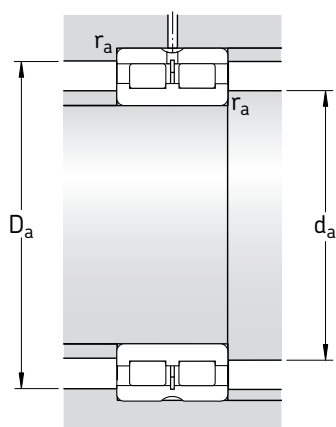

Dimensions								Abutment and fillet dimensions				
d	d ₁	D ₁	E	b ₁	K	r _{1,2} min	s ¹⁾	d _a min	d _{as} ²⁾	D _a max	r _a max	
mm								mm				
280	309	326	332,4	8	4	2	4	290	305	340	2	
	308	326	332,4	8	4	2	–	290	305	340	2	
	309	–	332,4	8	4	2	4	290	–	340	2	
	316	344	353,34	9,4	5	2,1	6	291	312	369	2	
	317	343	353,34	9,4	5	2,1	–	291	312	369	2	
	317	–	353,34	9,4	5	2,1	6	291	–	369	2	
	320	372	389	9,4	5	4	10	298	314	402	3	
	300	329	349	356,7	9,4	5	2,1	6	311	325	369	2
		329	349	356,7	9,4	5	2,1	–	311	325	369	2
		329	–	356,7	9,4	5	2,1	6	311	–	369	2
340		374	385,51	9,4	5	3	6	315	335	405	2,5	
341		374	385,51	9,4	5	3	–	315	335	405	2,5	
341		–	385,5	9,4	5	3	6	315	–	405	2,5	
352		418	433	9,4	5	4	9	318	343	442	3	
320		352	372	379,7	9,4	5	2,1	6	331	348	389	2
		352	372	379,7	9,4	5	2,1	–	331	348	389	2
		352	–	379,7	9,4	5	2,1	6	331	–	389	2
	368	400	412,27	9,4	5	3	6	335	362	425	2,5	
	368	400	412,27	9,4	5	3	–	335	362	425	2,5	
	368	–	412,3	9,4	5	3	6	335	–	425	2,5	
	370	434	449	9,4	5	4	9	338	360	462	3	
	340	369	389	396,9	9,4	5	2,1	6	351	365	409	2
		369	389	396,9	9,4	5	2,1	–	351	365	409	2
		369	–	396,9	9,4	5	2,1	6	351	–	409	2
386		418	430,11	9,4	5	3	6	355	380	445	2,5	
386		418	430,11	9,4	5	3	–	355	380	445	2,5	
386		–	430,1	9,4	5	3	6	355	–	445	2,5	
395		468	485	9,4	5	5	11	363	384	497	4	

¹⁾ Permissible axial displacement from the normal position of one bearing ring in relation to the other

²⁾ Recommended shaft abutment diameter for axially loaded bearings → page 582

Double row full complement cylindrical roller bearings
d 360 – 400 mm

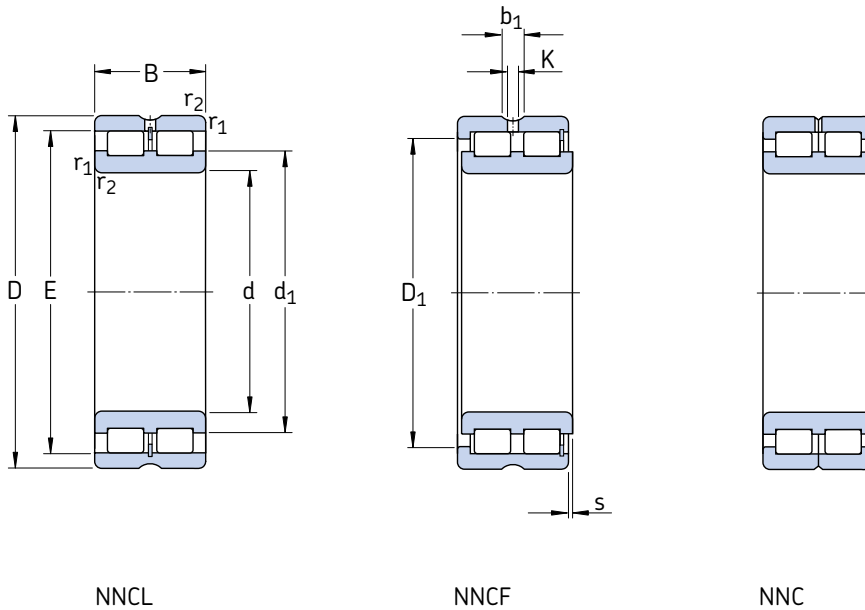

Principal dimensions			Basic load ratings		Fatigue load limit P_u	Speed ratings		Mass	Designation
d	D	B	dynamic C	static C_0		Refer- ence speed	Limiting speed		
mm			kN		kN	r/min		kg	–
360	440	80	935	2 550	224	560	700	26,5	NNCF 4872 CV
	440	80	935	2 550	224	560	700	27,0	NNC 4872 CV
	440	80	935	2 550	224	560	700	26,0	NNCL 4872 CV
	480	118	1 830	4 500	405	530	670	61,5	NNCF 4972 CV
	480	118	1 830	4 500	405	530	670	62,1	NNC 4972 CV
	480	118	1 830	4 500	405	530	670	60,8	NNCL 4972 CV
	540	243	4 460	8 650	735	500	630	195	NNCF 5072 CV
380	480	100	1 400	3 650	315	530	670	44,8	NNCF 4876 CV
	480	100	1 400	3 650	315	530	670	45,5	NNC 4876 CV
	480	100	1 400	3 650	315	530	670	44,0	NNCL 4876 CV
	520	140	2 380	5 700	500	500	630	91,5	NNCF 4976 CV
	520	140	2 380	5 700	500	500	630	92,4	NNC 4976 CV
	520	140	2 380	5 700	500	500	630	90,5	NNCL 4976 CV
	560	243	4 680	9 150	735	480	600	200	NNCF 5076 CV
400	500	100	1 420	3 750	325	500	630	46,2	NNCF 4880 CV
	500	100	1 420	3 750	325	500	630	46,5	NNC 4880 CV
	500	100	1 420	3 750	325	500	630	45,9	NNCL 4880 CV
	540	140	2 420	6 000	520	480	600	95,5	NNCF 4980 CV
	540	140	2 420	6 000	520	480	600	96,5	NNC 4980 CV
	540	140	2 420	6 000	520	480	600	94,5	NNCL 4980 CV
	600	272	5 500	11 000	900	450	560	270	NNCF 5080 CV

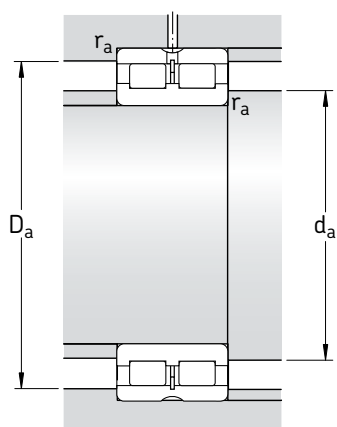

Dimensions								Abutment and fillet dimensions			
d	d ₁ ~	D ₁ ~	E	b ₁	K	r _{1,2} min	s ¹⁾	d _a min	d _{as} ²⁾	D _a max	r _a max
mm								mm			
360	392	412	419,8	9,4	5	2,1	6	371	388	429	2
	392	412	419,8	9,4	5	2,1	–	371	388	429	2
	392	–	419,8	9,4	5	2,1	6	371	–	429	2
	404	436	448	9,4	5	3	6	375	398	465	2,5
	404	436	448	9,4	5	3	–	375	398	465	2,5
	404	–	448	9,4	5	3	6	375	–	465	2,5
	412	486	503	9,4	5	5	11	383	402	517	4
380	421	446	455,8	9,4	5	2,1	6	391	415	469	2
	421	446	455,8	9,4	5	2,1	–	391	415	469	2
	421	–	455,8	9,4	5	2,1	6	391	–	469	2
	431	468	481,35	9,4	5	4	7	398	424	502	3
	431	468	481,35	9,4	5	4	–	398	424	502	3
	431	–	481,4	9,4	5	4	7	398	–	502	3
	431	504	521	9,4	5	5	11	403	420	537	4
400	435	461	470,59	9,4	5	2,1	6	411	430	489	2
	435	461	470,59	9,4	5	2,1	–	411	430	489	2
	435	–	470,59	9,4	5	2,1	6	411	–	489	2
	451	488	501,74	9,4	5	4	7	418	444	522	3
	451	488	501,74	9,4	5	4	–	418	444	522	3
	451	–	501,7	9,4	5	4	7	418	–	522	3
	460	540	558	9,4	5	5	11	423	449	577	4

¹⁾ Permissible axial displacement from the normal position of one bearing ring in relation to the other

²⁾ Recommended shaft abutment diameter for axially loaded bearings → **page 582**

Sealed double row full complement cylindrical roller bearings
d 20 – 120 mm

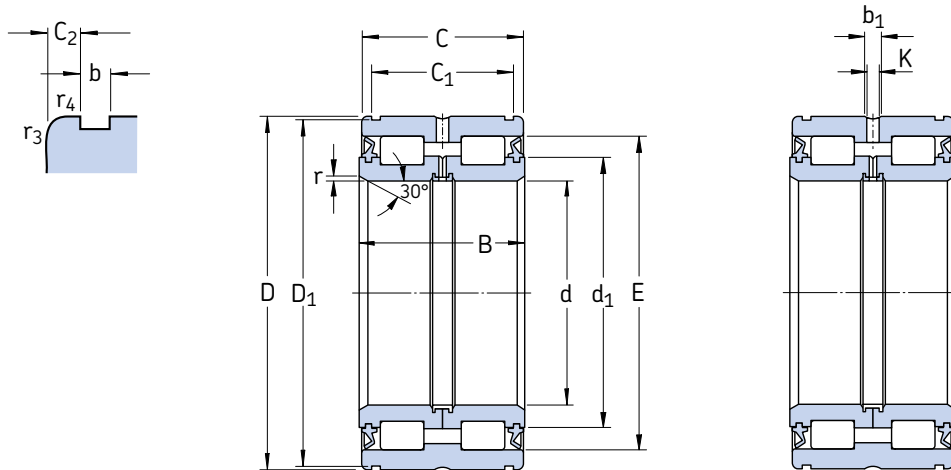

Principal dimensions				Basic load ratings		Fatigue load limit P_u	Limiting speed	Mass	Designation
d	D	B	C	dynamic C	static C_0				
mm				kN		kN	r/min	kg	–
20	42	30	29	44	52	5,4	3 600	0,21	NNF 5004 ADA-2LSV
25	47	30	29	48,4	62	6,4	3 000	0,23	NNF 5005 ADA-2LSV
30	55	34	33	57,2	75	7,8	2 600	0,35	NNF 5006 ADA-2LSV
35	62	36	35	70,4	91,5	10,2	2 200	0,45	NNF 5007 ADA-2LSV
40	68	38	37	85,8	116	13,4	2 000	0,53	NNF 5008 ADA-2LSV
45	75	40	39	102	146	17	1 800	0,68	NNF 5009 ADA-2LSV
50	80	40	39	108	160	18,6	1 700	0,73	NNF 5010 ADA-2LSV
55	90	46	45	128	193	22,8	1 500	1,10	NNF 5011 ADA-2LSV
60	95	46	45	134	208	25	1 400	1,20	NNF 5012 ADA-2LSV
65	100	46	45	138	224	26,5	1 300	1,30	NNF 5013 ADA-2LSV
70	110	54	53	205	325	40,5	1 200	1,85	NNF 5014 ADA-2LSV
75	115	54	53	216	355	44	1 100	2,00	NNF 5015 ADA-2LSV
80	125	60	59	251	415	53	1 000	2,70	NNF 5016 ADA-2LSV
85	130	60	59	270	430	55	1 000	2,75	NNF 5017 ADA-2LSV
90	140	67	66	319	550	69,5	900	3,80	NNF 5018 ADA-2LSV
95	145	67	66	330	570	71	900	3,95	NNF 5019 ADA-2LSV
100	150	67	66	336	570	68	850	4,05	NNF 5020 ADA-2LSV
110	170	80	79	413	695	81,5	750	6,45	NNF 5022 ADA-2LSV
120	180	80	79	429	750	86,5	700	6,90	NNF 5024 ADA-2LSV

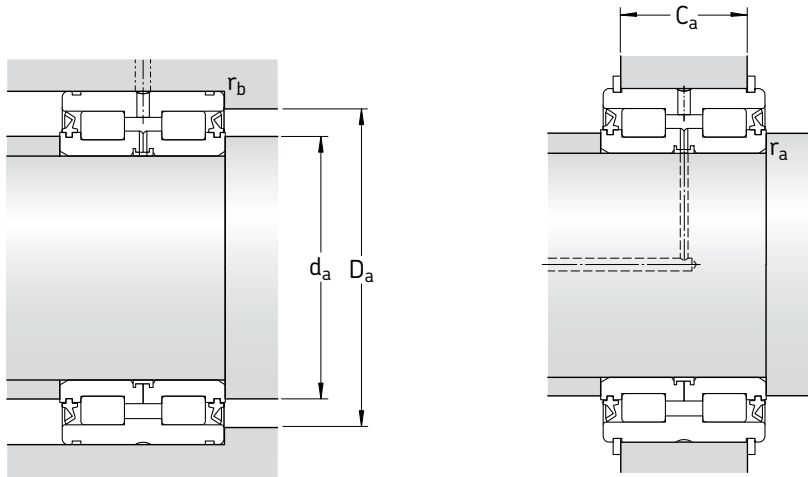

Dimensions										Abutment and fillet dimensions ¹⁾							Appropriate snap rings ²⁾ Designations Seeger DIN 471		
d	d ₁ ~	D ₁ ~	E	C ₁ +0,2	C ₂	b	b ₁	K	r min	r _{3,4} min	d _a min	d _{as} ³⁾	D _a max	C _{a1} -0,2	C _{a2} -0,2	r _a max	r _b max		
mm											mm							-	
20	28,1	40	35,6	24,7	2,15	1,9	4,5	3	0,5	0,3	24	26,9	38	21,5	21	0,3	0,3	SW 42	42x1,75
25	33	44,8	40,4	24,7	2,15	1,8	4,5	3	0,5	0,3	29	31,7	45	21,5	21	0,3	0,3	SW 47	47x1,75
30	39	53	47,9	28,2	2,4	2,1	4,5	3	0,5	0,3	34	38	53	25	24	0,3	0,3	SW 55	55x2
35	45	59,8	54,5	30,2	2,4	2,1	4,5	3	0,5	0,3	39	43,3	60	27	26	0,3	0,3	SW 62	62x2
40	50,5	65,8	61	32,2	2,4	2,7	4,5	3	0,8	0,6	44	48,8	63	28	27	0,4	0,6	SW 68	68x2,5
45	56,4	72,8	67,7	34,2	2,4	2,7	4,5	3	0,8	0,6	49	54,6	70	30	29	0,4	0,6	SW 75	75x2,5
50	61,2	77,8	72,5	34,2	2,4	2,7	4,5	3	0,8	0,6	54	59,4	75	30	29	0,4	0,6	SW 80	80x2,5
55	68	87,4	80	40,2	2,4	3,2	4,5	3,5	1	0,6	59,6	66	85	35	34	0,6	0,6	SW 90	90x3
60	73	92,4	85	40,2	2,4	3,2	4,5	3,5	1	0,6	65	71	90	35	34	0,6	0,6	SW 95	95x3
65	78	97,4	90	40,2	2,4	3,2	4,5	3,5	1	0,6	70	76	95	35	34	0,6	0,6	SW 100	100x3
70	85	107	100	48,2	2,4	4,2	5	3,5	1	0,6	75	82,5	105	43	40	0,6	0,6	SW 110	110x4
75	91	112	106	48,2	2,4	4,2	5	3,5	1	0,6	80	88,5	110	43	40	0,6	0,6	SW 115	115x4
80	97	122	113,5	54,2	2,4	4,2	5	3,5	1,5	0,6	86	94,3	120	49	46	1,5	0,6	SW 125	125x4
85	101	127	119,5	54,2	2,4	4,2	5	3,5	1,5	0,6	91	98,3	125	49	46	1,5	0,6	SW 130	130x4
90	109	137	127,5	59,2	3,4	4,2	5	3,5	1,5	0,6	96	106	135	54	51	1,5	0,6	SW 140	140x4
95	113	142	131	59,2	3,4	4,2	6	3,5	1,5	0,6	101	110	140	54	51	1,5	0,6	SW 145	145x4
100	118	147	138	59,2	3,4	4,2	6	3,5	1,5	0,6	106	115	145	54	51	1,5	0,6	SW 150	150x4
110	132	167	154,5	70,2	4,4	4,2	6	3,5	1,8	0,6	117	128	165	65	62	1	0,6	SW 170	170x4
120	141	176	164	71,2	3,9	4,2	6	3,5	1,8	0,6	127	138	175	65	63	1	0,6	SW 180	180x4

¹⁾ The values for C_{a1} apply for SW snap rings, the values for C_{a2} for snap rings according to DIN 471

²⁾ Snap rings are not supplied with the bearing and must be ordered separately

³⁾ Recommended shaft abutment diameter for axially loaded bearings → page 582

Sealed double row full complement cylindrical roller bearings
d 130 – 240 mm

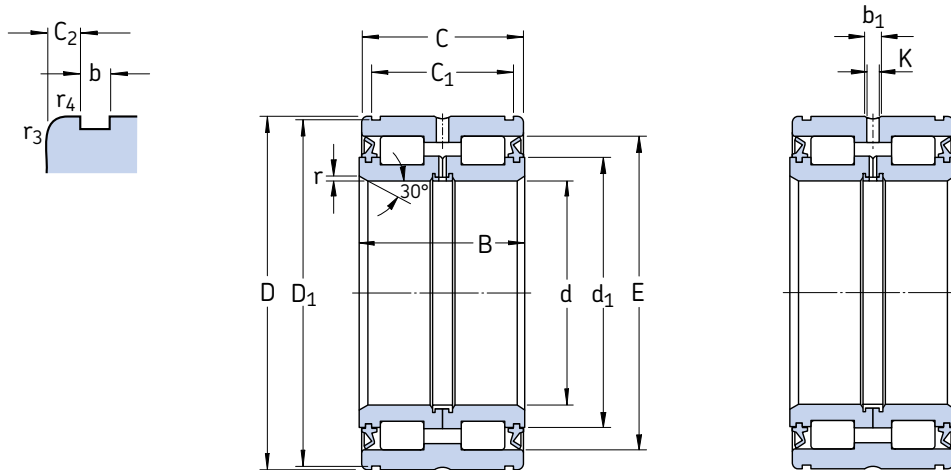

Principal dimensions				Basic load ratings		Fatigue load limit P_u	Limiting speed	Mass	Designation
d	D	B	C	dynamic C	static C_0				
mm				kN		kN	r/min	kg	–
130	190	80	79	446	815	91,5	670	7,50	319426 DA-2LS NNF 5026 ADA-2LSV
	200	95	94	616	1 040	120	630	10,5	
140	200	80	79	468	865	96,5	630	8,00	319428 DA-2LS NNF 5028 ADA-2LSV
	210	95	94	644	1 120	127	600	11,0	
150	210	80	79	468	900	96,5	560	8,40	319430 DA-2LS NNF 5030 ADA-2LSV
	225	100	99	748	1 290	143	560	13,5	
160	220	80	79	501	1 000	106	530	8,80	319432 DA-2LS NNF 5032 ADA-2LSV
	240	109	108	781	1 400	153	500	16,5	
170	230	80	79	512	1 060	110	530	9,30	319434 DA-2LS NNF 5034 ADA-2LSV
	260	122	121	1 010	1 800	193	480	22,5	
180	240	80	79	528	1 100	114	500	9,80	319436 DA-2LS NNF 5036 ADA-2LSV
	280	136	135	1 170	2 120	228	450	30,0	
190	260	80	79	550	1 180	120	450	12,7	319438 DA-2LS NNF 5038 ADA-2LSV
	290	136	135	1 190	2 200	236	430	31,5	
200	270	80	79	561	1 250	125	430	13,2	319440 DA-2LS NNF 5040 ADA-2LSV
	310	150	149	1 450	2 900	300	400	42,0	
220	340	160	159	1 610	3 100	315	360	53,5	NNF 5044 ADA-2LSV
240	360	160	159	1 680	3 350	335	340	57,5	NNF 5048 ADA-2LSV

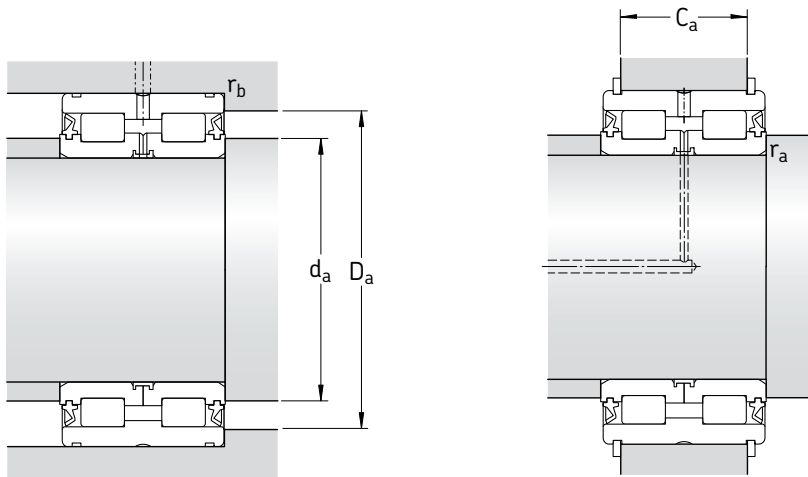

Dimensions											Abutment and fillet dimensions ¹⁾						Appropriate snap rings ²⁾ Designations Seeger DIN 471		
d	d ₁ ~	D ₁ ~	E	C ₁ +0,2	C ₂	b	b ₁	K	r min	r _{3,4} min	d _a min	d _{as} ³⁾	D _a max	C _{a1} -0,2	C _{a2} -0,2	r _a max	r _b max		
mm											mm						-		
130	151	186	173,1	71,2	3,9	4,2	6	3,5	1,8	0,6	137	147	185	65	63	1	0,6	SW 190	190x4
	155	196	183,5	83,2	5,4	4,2	7	4	1,8	0,6	137	150	195	77	75	1	0,6	SW 200	200x4
140	160	196	182,4	71,2	3,9	4,2	7	4	1,8	0,6	147	156	195	65	63	1	0,6	SW 200	200x4
	167	206	195,5	83,2	5,4	5,2	7	4	1,8	0,6	147	162	205	77	73	1	0,6	SW 210	210x5
150	175	206	197	71,2	3,9	5,2	7	4	1,8	0,6	157	171	205	65	61	1	0,6	SW 210	210x5
	177	221	209	87,2	5,9	5,2	7	4	2	0,6	157	172	220	81	77	2	0,6	SW 225	225x5
160	184	216	206,5	71,2	3,9	5,2	7	4	1,8	0,6	167	180	215	65	61	1	0,6	SW 220	220x5
	191	236	222,6	95,2	6,4	5,2	7	4	2	0,6	167	186	235	89	85	2	0,6	SW 240	240x5
170	194	226	216,1	71,2	3,9	5,2	7	4	1,8	0,6	177	190	225	65	61	1	0,6	SW 230	230x5
	203	254	239	107,2	6,9	5,2	7	4	2	0,6	177	197	255	99	97	2	0,6	SW 260	260x5
180	203	236	225,6	71,2	3,9	5,2	7	4	1,8	0,6	177	199	225	65	61	1	0,6	SW 240	240x5
	220	274	259	118,2	8,4	5,2	8	4	2	0,6	187	214	275	110	108	2	0,6	SW 280	280x5
190	218	254	240	73,2	2,9	5,2	7	4	1,8	0,6	197	214	255	65	63	1	0,6	SW 260	260x5
	228	284	267,3	118,2	8,4	5,2	8	4	2	0,6	197	222	285	110	108	2	0,6	SW 290	290x5
200	227	264	249,6	73,2	2,9	5,2	7	4	1,8	0,6	207	223	265	65	63	1	0,6	SW 270	270x5
	245	304	284	128,2	10,4	6,3	8	4	2	0,6	207	239	305	120	116	2	0,6	SW 310	310x6
220	264	334	308,5	138,2	10,4	6,3	8	6	2	1	227	256	334	130	126	2	1	SW 340	340x6
240	283	354	327,5	138,2	10,4	6,3	9,4	6	2	1	247	275	354	130	126	2	1	SW 360	360x6

¹⁾ The values for C_{a1} apply for SW snap rings, the values for C_{a2} for snap rings according to DIN 471

²⁾ Snap rings are not supplied with the bearing and must be ordered separately

³⁾ Recommended shaft abutment diameter for axially loaded bearings → page 582



Taper roller bearings



Single row taper roller bearings..... 605

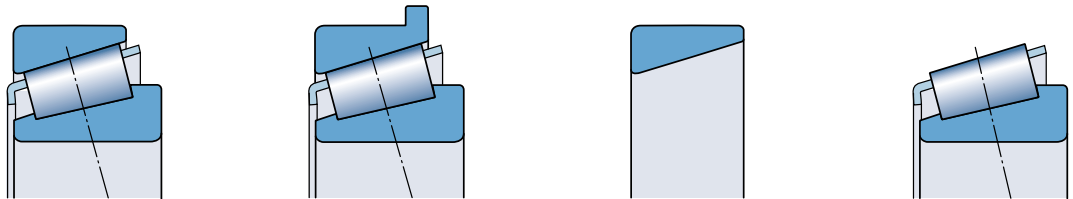

Paired single row taper roller bearings 671

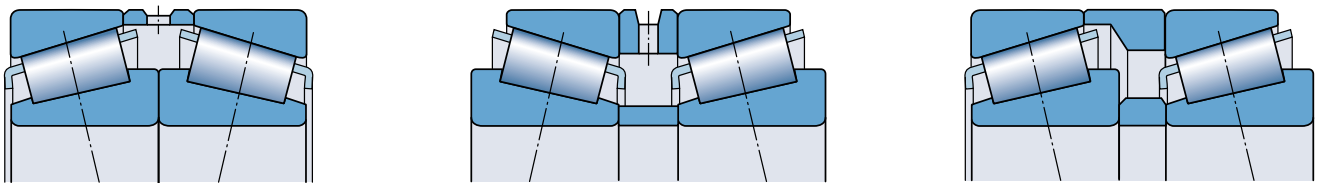

Taper roller bearings

Taper roller bearings are produced by SKF in many designs and sizes to match their many uses. The most prevalent are listed in this catalogue, i.e.

- single row taper roller bearings (→ **fig. 1**)
- paired single row taper roller bearings (→ **fig. 2**).

The double row and four-row taper roller bearings (→ **fig. 3**), which are mainly used for rolling mill bearing arrangements, round off the comprehensive SKF standard range. Details of these bearings can be found in the “SKF Interactive Engineering Catalogue” available on CD-ROM or online at www.skf.com.

SKF also manufactures sealed, greased and preadjusted units based on taper roller bearings, such as

- hub bearing units for passenger cars (→ **fig. 4**)
- hub bearing units for trucks (→ **fig. 5**)
- tapered bearing units for railbound vehicles (→ **fig. 6**).

Details of these bearings can be found in the special publications, which can be furnished on request.

Fig. 1

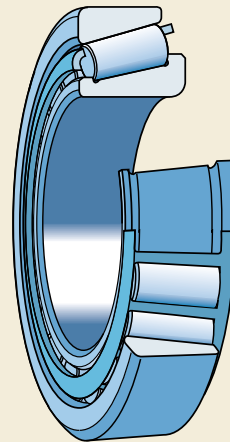

Fig. 2

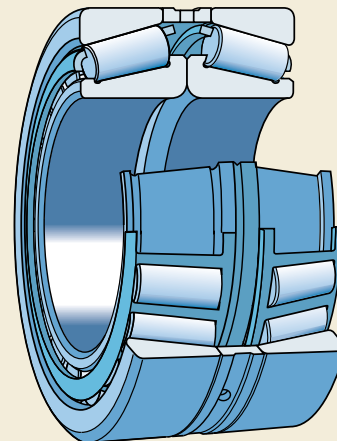

Fig. 3

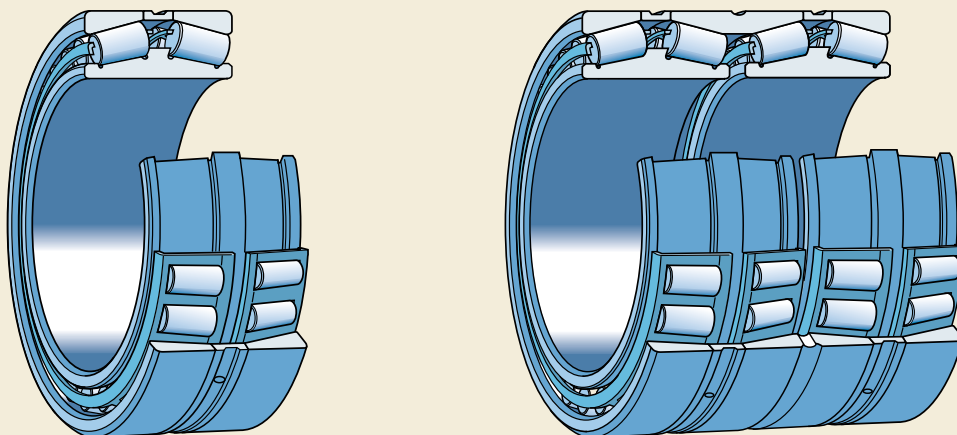

Fig. 4



Design features

Taper roller bearings have tapered inner and outer ring raceways between which tapered rollers are arranged. The projection lines of all the tapered surfaces meet at a common point on the bearing axis. Their design makes taper roller bearings particularly suitable for the accommodation of combined (radial and axial) loads. The axial load carrying capacity of the bearings is largely determined by the contact angle α (\rightarrow **fig. 7**); the larger α , the higher the axial load carrying capacity. An indication of the angle size is given by the calculation factor e ; the larger the value of e , the larger the contact angle and the greater the suitability of the bearing for carrying axial loads.

Taper roller bearings are generally separable, i.e. the cone, consisting of the inner ring with roller and cage assembly, can be mounted separately from the cup (outer ring).

SKF taper roller bearings have the logarithmic contact profile that provides optimum stress distribution over the roller/raceway contacts. The special design of the sliding surfaces of the guide flange and large roller ends considerably promote lubricant film formation in the roller end/flange contacts. The resulting benefits include increased operational reliability and reduced sensitivity to misalignment.

Fig. 5



Fig. 6



Fig. 7

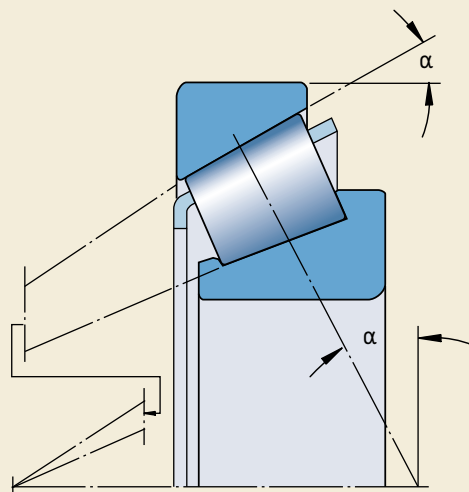



Single row taper roller bearings

Designs	606
Standard design	606
CL7C specification bearings	606
Bearings with flanged outer ring	607
SKF Explorer class bearings	607
Bearing designations	607
Metric bearings.....	607
Inch bearings	608
Bearing data – general	609
Dimensions	609
Tolerances.....	609
Internal clearance and preload	610
Misalignment.....	610
Cages.....	610
Minimum load.....	611
Equivalent dynamic bearing load.....	612
Equivalent static bearing load.....	612
Determining axial force for bearings mounted singly or paired in tandem	612
Supplementary designations.....	614
Design of bearing arrangements	615
Fits for inch bearings	615
Product tables	618
Metric single row taper roller bearings	618
Inch single row taper roller bearings.....	640
Metric single row taper roller bearings with flanged outer ring.....	668

Designs

The SKF standard range of single row taper roller bearings (→ **fig. 1**) covers the popular sizes of metric bearings manufactured to ISO 355:1977 and inch bearings which follow the ANSI/ABMA standard 19.2-1994. The range can be divided into

- bearings for general use
- high-performance bearings manufactured to the CL7C specifications
- bearings with a flanged outer ring

as well as “Paired single row taper roller bearings” shown from **page 671** onwards.

For bearing arrangements operating in particularly difficult environments, for example, where the lubricating oil may be highly contaminated, where high operating temperatures prevail or where heavy deforming loads can be expected, SKF can supply particularly wear-resistant taper roller bearings. Details are available on request.

Standard design

SKF taper roller bearings for general use, including SKF bearings to Q specifications, have been optimized with regard to

- sliding contact surfaces of the guide flange of the inner ring
- roller end faces
- raceway contact profile.

In addition, highly accurate manufacturing processes make adjustment of the bearings against each other more reliable, which dramatically improves performance especially during the very first hours of operation.

Fig. 1

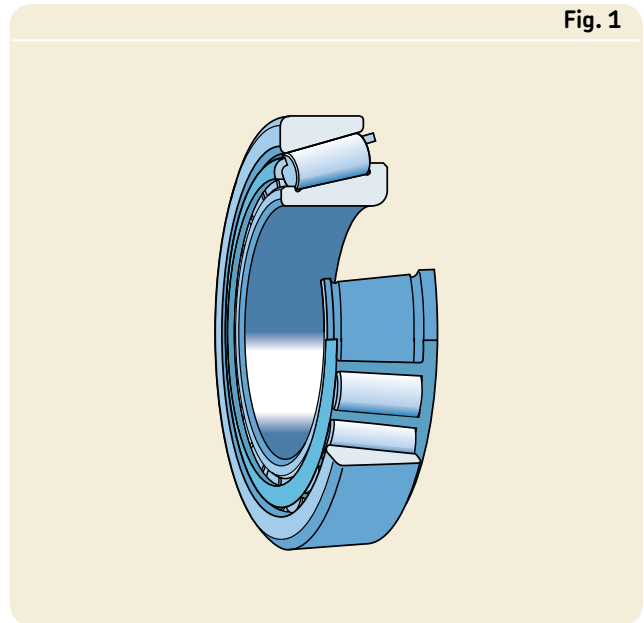

CL7C specification bearings

SKF taper roller bearings produced to the CL7C specifications are intended for bearing arrangements supporting heavy axial loads, for example, gearbox pinion bearing arrangements. These bearings, which are mounted with preload, have special friction characteristics, higher running accuracy and higher axial load carrying capacity to provide a constant, accurate mesh.

In contrast to the bearings for general use, CL7C specification bearings can be adjusted to within narrow limits using the frictional torque method, which considerably simplifies the adjustment process.

With CL7C specification bearings there is practically no running-in wear. As a hydrodynamic lubricant film in the roller end/flange contacts is established from the outset, there is virtually no loss of preload and the preload can be maintained at a constant high level throughout operation.

Fig. 2

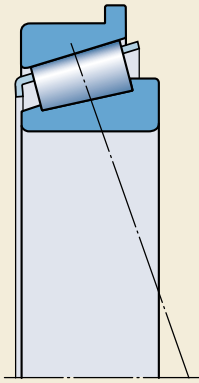

Bearings with flanged outer ring

Certain sizes of SKF single row taper roller bearings are also available with a flange on the outer ring (→ **fig. 2**). Bearings having this external flange can be axially located in the housing to provide a simplified, more compact bearing arrangement. The housing bore is simpler to produce, as no shoulders are required.

SKF Explorer class bearings

High performance SKF Explorer taper roller bearings are shown with an asterisk in the product tables. SKF Explorer bearings retain the designation of the earlier standard bearings, e.g. 30310 J2/Q. However, each bearing and its box are marked with the name “EXPLORER”.

Upon request other standard taper roller bearings can be manufactured in the SKF Explorer performance class. Moreover, the range of SKF Explorer taper roller bearings is being continuously extended. Therefore SKF recommends checking the actual assortment by contacting the local SKF representative.

Bearing designations

Metric bearings

The designations of metric taper roller bearings with standardized dimensions according to ISO follow one of the following principles:

- The series designations established in ISO 355:1977 comprising three symbols, a figure representing the contact angle and two letters for the diameter and width series followed by a three figure bore diameter identification (d in mm). The SKF designations are prefixed by the letter T, e.g. T2ED 045.
- Designations established prior to 1977 based on the system shown in **diagram 3**, **page 149**, in the section “Designations”, e.g. 32206.

Metric bearings with a J in the prefix follow the ABMA designation system, which is similar to the system used for inch bearings, see ANSI/ABMA Standard 19.2-1994.

Single row taper roller bearings

Inch bearings

Inch taper roller bearings are designated according to the ANSI/ABMA standard.

Metric bearings that belong to the same series maintain the same relative cross section regardless of their size. This is not the case with inch bearings. All inch bearings within a series use the same cage and roller assembly but the inner and outer rings can have different sizes and designs.

Any cone (the inner ring with cage and roller assembly) can be assembled with any cup (the outer ring) belonging to the same bearing series. For this reason the cone and cup have individual designations and can be supplied separately or as complete bearings (→ **fig. 3**). The designations of the cones and cups as well as the series consist of a three to six-figure number which may be prefixed by one of the following letters or combination of letters: EL, LL, L, LM, M, HM, H, HH and EH. The prefixes characterize a bearing series from extra light to extra heavy. The basic principles of this system are described in ANSI/ABMA Standard 19.2-1994.

The complete bearing designation consists of the cone designation followed by that of the cup, the two designations being separated by an oblique stroke (→ **table 1**).

To shorten the complete bearing designations, abbreviations are used (→ **table 1**).



Fig. 3

Table 1

Designations of inch taper roller bearings			
Designations (Examples)			
Cone	Cup	Complete bearing	Series
Complete bearing designation not abbreviated (old ABMA designations)			
4580/2/Q 9285/CL7C	4535/2/Q 9220/CL7C	4580/2/4535/2/Q 9285/9220/CL7C	4500 9200
Abbreviated complete bearing designations (new ABMA designations)			
LM 11749/QVC027 JL 69349 A/Q HM 89449/2/QCL7C H 913842/CL7C	LM 11710/QVC027 JL 69310/Q HM 89410/2/QCL7C H 913810/CL7C	LM 11749/710/QVC027 JL 69349 A/310/Q HM 89449/2/410/2/QCL7C H 913842/810/CL7C	LM 11700 L 69300 HM 89400 H 913800

Bearing data – general

Dimensions

Metric bearings

The boundary dimensions of metric single row taper roller bearings listed in the product tables conform to ISO 355-1977 except for those bearings having a J in the designation prefix. These conform to the ANSI/ABMA Standard 19.1-1987.

Inch bearings

The boundary dimensions of inch bearings conform to AFBMA Standard 19-1974 (ANSI B3.19-1975). ANSI/ABMA Standard 19.2-1994 has subsequently replaced this standard, but this later standard no longer includes dimensions.

Tolerances

The inner rings with roller and cage assembly and outer rings of SKF taper roller bearings having the same designation are interchangeable. The tolerance for the total abutment width T of the bearing will not be exceeded if the cones and cups are interchanged.

Metric bearings

SKF single row metric taper roller bearings are manufactured to Normal tolerances as standard. Some bearings are also available with reduced width tolerance to tolerance class CLN specifications. Bearings having a J in the prefix are produced as standard to tolerance class CLN specifications.

All bearings having an outside diameter above 420 mm have dimensional accuracy to tolerance class Normal specifications but the running accuracy is better than Normal, being to P6 specifications.

The values for Normal and CLN tolerances correspond to ISO 492:2002 (classes Normal and 6X) and are shown in **tables 6 and 7** on **pages 128 and 129**. The values for P6 running accuracy are in accordance with DIN 620-3:1964, which was withdrawn in 1988.

Inch bearings

SKF single row inch taper roller bearings are produced to Normal tolerances as standard. On request, they may be supplied with higher accuracy to CL3 or CLO tolerance class specifications and/or reduced width tolerances. Cones and cups having a width tolerance that differs from the Normal tolerance are identified by a designation suffix according to **table 2** where the actual tolerance values are provided.

The values for CL3, CLO and Normal tolerances conform to ANSI/ABMA Standard 19.2-1994 and are listed in **table 9** on **page 131**. The ISO standard 578:1987, which also covered these tolerance classes, was withdrawn in 1997.

CL7C specification bearings

The tolerances for CL7C specification bearings correspond to Normal tolerances except for the running accuracy which has been tightened considerably. The appropriate values are provided together with the Normal tolerances in **table 6** on **page 128**.

Table 2

Modified width tolerances of cups and cones of inch bearings

Designation suffix	Width tolerance ¹⁾	
	max	min
–	mm	
/1	+0,025	0
/1A	+0,038	+0,013
/-1	0	-0,025
/11	+0,025	-0,025
/15	+0,038	-0,038
/2	+0,051	0
/2B	+0,076	+0,025
/2C	+0,102	+0,051
/-2	0	-0,051
/22	+0,051	-0,051
/3	+0,076	0
/-3	0	-0,076
/4	+0,102	0

¹⁾ The total width tolerance for a complete bearing is equal to the sum of the tolerances for the cone and cup, e.g. for bearing K-47686/2/K-47620/3 the tolerance is +0,127/0 mm

Single row taper roller bearings

Internal clearance and preload

The internal clearance of single row taper roller bearings can only be obtained after mounting and is determined by adjustment of the bearing against a second bearing, which provides location in the opposite direction. Further details can be found in the section “Bearing preload”, starting on **page 206**.

Adjustment and running in

When adjusting taper roller bearings against each other, the bearings must be rotated, so that the rollers assume their correct position, i.e. the large end face of the rollers must be in contact with the guide flange.

Conventional taper roller bearings normally have a relatively high frictional moment during the first hours of operation, which drops to a lower level after the running-in period. During this running-in period, bearing temperature increases rapidly because of the high initial friction and falls off to an equilibrium level as the running-in phase is completed.

This running-in phase is considerably reduced with bearings made to the SKF “Q” specification. In these bearings, the initial friction is also much lower, so that temperature increase is almost negligible. This also applies to the high-performance CL7C specification bearings, which are designed for easy adjustment.

Misalignment

The ability of a conventional single row taper roller bearing to accommodate angular misalignment of the inner ring with respect to the outer ring is limited to a few minutes of arc. SKF bearings have the logarithmic contact profile and can tolerate misalignments of approximately 2 to 4 minutes of arc.

These guideline values apply provided the position of the shaft and housing axes are constant. Larger misalignment is possible, depending on the load and requisite service life. For additional information, please contact the SKF application engineering service.

Cages

SKF single row taper roller bearings are fitted with one of the following cages (→ **fig. 4**)

- a pressed window-type steel cage, roller centred, no designation suffix or suffix J1, J2 or J3 (**a**)
- an injection moulded window-type cage of glass fibre reinforced polyamide 6,6, roller centred, designation suffix TN9 (**b**).

Note

Taper roller bearings with a polyamide 6,6 cage can be operated at temperatures up to +120 °C. The lubricants generally used for rolling bearings do not have a detrimental effect on polyamide cage properties, with the exception of a few synthetic oils and greases with a synthetic oil base, and lubricants containing a high proportion of EP additives when used at high temperatures.

For bearing arrangements, which are to be operated at continuously high temperatures or under arduous conditions, SKF recommends using bearings with a pressed steel or high-temperature polymer cage.

For detailed information about the temperature resistance and the applicability of cages, please refer to the section “Cage materials”, starting on **page 140**.

Minimum load

In order to provide satisfactory operation, taper roller bearings, like all ball and roller bearings, must always be subjected to a given minimum load, particularly if they are to operate at high speeds or are subjected to high accelerations or rapid changes in the direction of load. Under such conditions, the inertia forces of the rollers and cage, and the friction in the lubricant, can have a detrimental influence on the rolling conditions in the bearing arrangement and may cause damaging sliding movements to occur between the rollers and raceways.

The requisite minimum radial load to be applied to SKF standard taper roller bearings can be estimated from

$$F_{rm} = 0,02 C$$

and for SKF Explorer bearings from

$$F_{rm} = 0,017 C$$

where

F_{rm} = minimum radial load, kN

C = basic dynamic load rating, kN
(→ product tables)

When starting up at low temperatures or when the lubricant is highly viscous, even greater minimum loads may be required. The weight of the components supported by the bearing, together with external forces, generally exceeds the requisite minimum load. If this is not the case, the single row taper roller bearing must be

subjected to an additional radial load, which can be achieved easily by applying preload. For additional information, please refer to the section “Bearing preload”, starting on **page 206**.

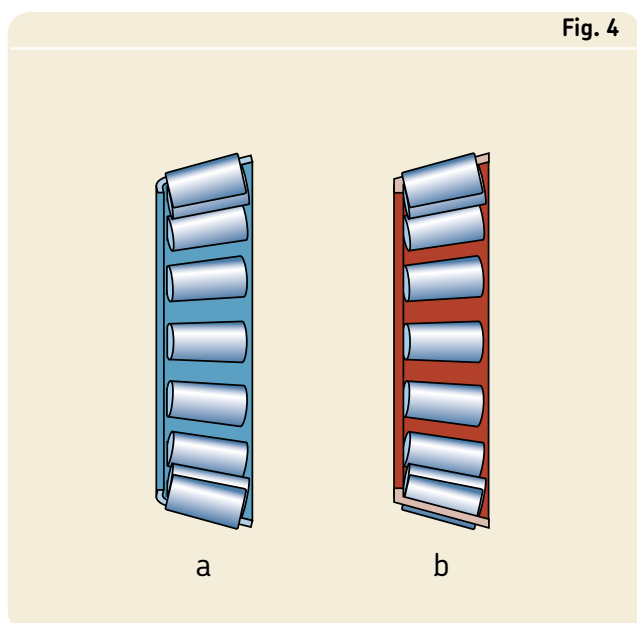

Single row taper roller bearings

Equivalent dynamic bearing load

$$P = F_r \quad \text{when } F_a/F_r \leq e$$

$$P = 0,4 F_r + Y F_a \quad \text{when } F_a/F_r > e$$

The values of the calculation factors e and Y can be found in the product tables.

Equivalent static bearing load

$$P_0 = 0,5 F_r + Y_0 F_a$$

When $P_0 < F_r$, $P_0 = F_r$ should be used. The value of the calculation factor Y_0 can be found in the product tables.

Determining axial force for bearings mounted singly or paired in tandem

When a radial load is applied to a single row taper roller bearing, the load is transmitted from one raceway to the other at an angle to the bearing axis and an internal axial force will be induced in the bearing. This must be considered when calculating the equivalent bearing loads for bearing arrangements consisting of two single bearings and/or bearing pairs arranged in tandem.

The necessary equations are provided in **table 3** for the various bearing arrangements and load cases. The equations are only valid if the bearings are adjusted against each other to practically zero clearance, but without any preload. In the arrangements shown, bearing A is subjected to a radial load F_{rA} and bearing B to radial load F_{rB} . Values of the loads F_{rA} and F_{rB} are always considered positive even when they act in the direction opposite to that shown in the figures. The radial loads act at the pressure centres of the bearings (dimension a in the product tables).

In addition an external force K_a acts on the shaft (or on the housing). Cases 1c and 2c are also valid when $K_a = 0$. Values of the factor Y can be found in the product tables.

Table 3

Axial loading of bearing arrangements incorporating two single row taper roller bearings and/or bearing pairs in tandem

Arrangement	Load case	Axial forces	
<p>Back-to-back</p>	<p>1a) $\frac{F_{rA}}{Y_A} \geq \frac{F_{rB}}{Y_B}$</p> <p>$K_a \geq 0$</p>	$F_{aA} = \frac{0,5 F_{rA}}{Y_A}$	$F_{aB} = F_{aA} + K_a$
	<p>1b) $\frac{F_{rA}}{Y_A} < \frac{F_{rB}}{Y_B}$</p> <p>$K_a \geq 0,5 \left(\frac{F_{rB}}{Y_B} - \frac{F_{rA}}{Y_A} \right)$</p>	$F_{aA} = \frac{0,5 F_{rA}}{Y_A}$	$F_{aB} = F_{aA} + K_a$
<p>Face-to-face</p>	<p>1c) $\frac{F_{rA}}{Y_A} < \frac{F_{rB}}{Y_B}$</p> <p>$K_a < 0,5 \left(\frac{F_{rB}}{Y_B} - \frac{F_{rA}}{Y_A} \right)$</p>	$F_{aA} = F_{aB} - K_a$	$F_{aB} = \frac{0,5 F_{rB}}{Y_B}$
	<p>2a) $\frac{F_{rA}}{Y_A} \leq \frac{F_{rB}}{Y_B}$</p> <p>$K_a \geq 0$</p>	$F_{aA} = F_{aB} + K_a$	$F_{aB} = \frac{0,5 F_{rB}}{Y_B}$
<p>Back-to-back</p>	<p>2b) $\frac{F_{rA}}{Y_A} > \frac{F_{rB}}{Y_B}$</p> <p>$K_a \geq 0,5 \left(\frac{F_{rA}}{Y_A} - \frac{F_{rB}}{Y_B} \right)$</p>	$F_{aA} = F_{aB} + K_a$	$F_{aB} = \frac{0,5 F_{rB}}{Y_B}$
	<p>2c) $\frac{F_{rA}}{Y_A} > \frac{F_{rB}}{Y_B}$</p> <p>$K_a < 0,5 \left(\frac{F_{rA}}{Y_A} - \frac{F_{rB}}{Y_B} \right)$</p>	$F_{aA} = \frac{0,5 F_{rA}}{Y_A}$	$F_{aB} = F_{aA} - K_a$
<p>Face-to-face</p>	<p>2c) $\frac{F_{rA}}{Y_A} > \frac{F_{rB}}{Y_B}$</p> <p>$K_a < 0,5 \left(\frac{F_{rA}}{Y_A} - \frac{F_{rB}}{Y_B} \right)$</p>	$F_{aA} = \frac{0,5 F_{rA}}{Y_A}$	$F_{aB} = F_{aA} - K_a$

Single row taper roller bearings

Supplementary designations

The designation suffixes used to identify certain features of SKF single row taper roller bearings are explained in the following.

- B** Steeper contact angle than standard design
- CLN** Reduced tolerances for ring widths and total (abutment) width; corresponds to ISO tolerance class 6X
- CLO** Accuracy to ABMA tolerance class 0 for inch bearings
- CL00** Accuracy to ABMA tolerance class 00 for inch bearings
- CL7A** High-performance design for pinion bearing arrangements (superseded by CL7C)
- CL7C** High-performance design for pinion bearing arrangements
- HA1** Case-hardened inner and outer rings
- HA3** Case-hardened inner ring
- HN1** Outer and inner rings with special surface heat treatment
- HN3** Inner ring with special surface heat treatment
- J** Pressed window-type steel cage, roller centred. A figure following the J indicates a different cage design
- P6** Dimensional and running accuracy to old ISO tolerance class 6, better than Normal
- Q** Optimized contact geometry and surface finish
- R** Flanged outer ring
- TN9** Injection moulded window-type cage of glass fibre reinforced polyamide 6,6, roller centred
- U.** U combined with a one-figure number identifies reduced total width tolerance. Examples:
 - U2 Total width tolerance +0,05/0 mm
 - U4 Total width tolerance +0,10/0 mm
- VA321** Optimized internal design
- VA606** Crowned raceway on bearing rings and special heat treatment
- VA607** Crowned raceway on bearing rings and special heat treatment
- VB022** Chamfer dimension at large outer ring side face 0,3 mm
- VB026** Chamfer dimension at large inner ring side face 3 mm
- VB061** Chamfer dimension at large inner ring side face 8 mm
- VB134** Chamfer dimension at large inner ring side face 1 mm
- VB406** Chamfer dimension at large inner ring side face 3 mm and at large outer ring side face 2 mm
- VB481** Chamfer dimension at large inner ring side face 8,5 mm
- VC027** Modified internal geometry for increased permissible misalignment
- VC068** Increased running accuracy and special heat treatment
- VE174** One locating slot in outer ring at large outer ring side face, increased running accuracy
- VQ051** Modified internal geometry for increased permissible misalignment
- VQ267** Reduced inner ring width tolerance, $\pm 0,025$ mm
- VQ495** As CL7C but with reduced or displaced tolerance for the outside diameter
- VQ506** Reduced inner ring width tolerance
- VQ507** As CL7C but with reduced or displaced tolerance for the outside diameter
- VQ523** As CL7C but with reduced inner ring width tolerance and reduced or displaced tolerance for the outside diameter
- VQ601** Accuracy to ABMA tolerance class 0 for inch bearings
- W** Modified ring width tolerance, +0,05/0 mm
- X** Boundary dimensions changed to conform to ISO

Design of bearing arrangements

When designing bearing arrangements incorporating single row taper roller bearings it is necessary to consider the special characteristics of these bearings. Because of their internal design, they cannot be used singly and a second bearing is required (→ **fig. 5**); alternatively a paired set (→ **fig. 6**) may be used. When the arrangement comprises two single row bearings they must be adjusted against each other as described under “Internal clearance and preload” (→ **page 610**).

A correctly dimensioned operational clearance or preload is vital to the correct performance of single row taper roller bearings and also to the operational reliability of the arrangement. If the operational clearance is too large, the full load carrying capacity of the bearing will not be exploited. If the preload is too great then frictional losses will increase, as will operating temperature. In both cases the bearing service life could be substantially reduced.

Fits for inch bearings

Suitable fits for inch taper roller bearings can be obtained based on the recommended fits for metric bearings. However, since inch bearings, in contrast to metric bearings, are machined to plus tolerances, the deviations for shaft and housing cannot be applied directly and must be modified to take account of the plus tolerances. Reference should therefore be made to the tables below, which provide the same degree of interference or clearance as the recommended metric tolerances:

- **Table 4:** Modified shaft diameter deviations g6, h6, j5, j6, js6, k5, k6, m5, m6, n6, p6.
- **Table 5:** Modified housing bore diameter deviations H7, J7, J6, K6, K7, M6, M7, N7, P7.

Fig. 5

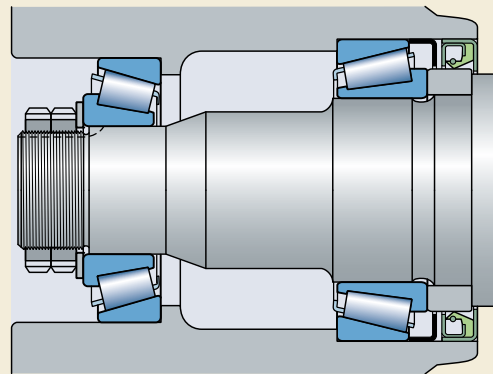
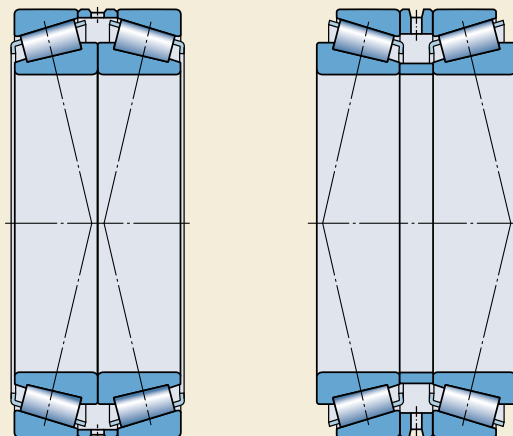

Fig. 6



Single row taper roller bearings

Table 4

Modified shaft diameter deviations for use with inch bearings													
Nominal diameter Shaft seating Bearing bore over incl.		Modified deviations for fits with clearance /interference according to											
		g6		h6		j5		j6		js6		k5	
		high	low	high	low	high	low	high	low	high	low	high	low
mm		µm											
10	18	+2	-4	+8	+2	+13	+10	+16	+10	+14	+7	+17	+14
18	30	+3	-7	+10	0	+15	+9	+19	+9	+17	+6	+21	+15
30	50	+3	-12	+12	-3	+18	+8	+23	+8	+20	+5	+25	+15
50	76,2	+5	-16	+15	-6	+21	+6	+27	+6	+25	+3	+30	+15
76,2	80	+5	-4	+15	+6	+21	+18	+27	+18	+25	+15	+30	+27
80	120	+8	-9	+20	+3	+26	+16	+33	+16	+31	+14	+38	+28
120	180	+11	-14	+25	0	+32	+14	+39	+14	+38	+12	+46	+28
180	250	+15	-19	+30	-4	+37	+12	+46	+12	+45	+10	+54	+29
250	304,8	+18	-24	+35	-7	+42	+9	+51	+9	+51	+9	+62	+29
304,8	315	+18	+2	+35	+19	+42	+35	+51	+35	+51	+35	+62	+55
315	400	+22	-3	+40	+15	+47	+33	+58	+33	+58	+33	+69	+55
400	500	+25	-9	+45	+11	+52	+31	+65	+31	+65	+31	+77	+56
500	609,6	+28	-15	+50	+7	-	-	+72	+29	+72	+29	+78	+51
609,6	630	+28	+10	+50	+32	-	-	+72	+54	+72	+54	+78	+76
630	800	+51	+2	+75	+26	-	-	+100	+51	+100	+51	+107	+76
800	914,4	+74	-6	+100	+20	-	-	+128	+48	+128	+48	+136	+76

Modified shaft diameter deviations for use with inch bearings													
Nominal diameter Shaft seating Bearing bore over incl.		Modified deviations for fits with clearance /interference according to											
		k6		m5		m6		n6		p6			
		high	low	high	low	high	low	high	low	high	low	high	low
mm		µm											
10	18	+20	+14	+23	+20	+26	+20	+31	+25	+37	+31		
18	30	+25	+15	+27	+21	+31	+21	+38	+28	+45	+35		
30	50	+30	+15	+32	+22	+37	+22	+45	+30	+54	+39		
50	76,2	+36	+15	+39	+24	+45	+24	+54	+33	+66	+45		
76,2	80	+36	+27	+39	+36	+45	+36	+54	+45	+66	+57		
80	120	+45	+28	+48	+38	+55	+38	+65	+48	+79	+62		
120	180	+53	+28	+58	+40	+65	+40	+77	+52	+93	+68		
180	250	+63	+29	+67	+42	+76	+42	+90	+56	+109	+75		
250	304,8	+71	+29	+78	+45	+87	+45	+101	+59	+123	+81		
304,8	315	+71	+55	+78	+71	+87	+71	+101	+85	+123	+107		
315	400	+80	+55	+86	+72	+97	+72	+113	+88	+138	+113		
400	500	+90	+56	+95	+74	+108	+74	+125	+91	+153	+119		
500	609,6	+94	+51	+104	+77	+120	+77	+138	+95	+172	+129		
609,6	630	+94	+76	+104	+102	+120	+102	+138	+120	+172	+154		
630	800	+125	+76	+137	+106	+155	+106	+175	+126	+213	+164		
800	914,4	+156	+76	+170	+110	+190	+110	+212	+132	+256	+176		

Table 5

Modified housing bore diameter deviations for use with inch bearings

Nominal diameter Housing bore seating Bearing outside diameter over incl.		Modified deviations for fits with clearance/interference according to									
		H7		J7		J6		K6		K7	
		high	low	high	low	high	low	high	low	high	low
mm		µm									
30	50	+36	+25	+25	+14	+21	+19	+14	+12	+18	+7
50	80	+43	+25	+31	+13	+26	+19	+17	+10	+22	+4
80	120	+50	+25	+37	+12	+31	+19	+19	+7	+25	0
120	150	+58	+25	+44	+11	+36	+18	+22	+4	+30	-3
150	180	+65	+25	+51	+11	+43	+18	+29	+4	+37	-3
180	250	+76	+25	+60	+9	+52	+18	+35	+1	+43	-8
250	304,8	+87	+25	+71	+9	+60	+18	+40	-2	+51	-11
304,8	315	+87	+51	+71	+35	+60	+44	+40	+24	+51	+15
315	400	+97	+51	+79	+33	+69	+44	+47	+22	+57	+11
400	500	+108	+51	+88	+31	+78	+44	+53	+19	+63	+6
500	609,6	+120	+51	-	-	-	-	+50	+7	+50	-19
609,6	630	+120	+76	-	-	-	-	+50	+32	+50	+6
630	800	+155	+76	-	-	-	-	+75	+26	+75	-4
800	914,4	+190	+76	-	-	-	-	+100	+20	+100	-14
914,4	1 000	+190	+102	-	-	-	-	+100	+46	+100	+12
1 000	1 219,2	+230	+102	-	-	-	-	+125	+36	+125	-3

Nominal diameter Housing bore seating Bearing outside diameter over incl.		Modified deviations for fits with clearance/interference according to							
		M6		M7		N7		P7	
		high	low	high	low	high	low	high	low
mm		µm							
30	50	+7	+5	+11	0	+3	-8	-6	-17
50	80	+8	+1	+13	-5	+4	-14	-8	-26
80	120	+9	-3	+15	-10	+5	-20	-9	-34
120	150	+10	-8	+18	-15	+6	-27	-10	-43
150	180	+17	-8	+25	-15	+13	-27	-3	-43
180	250	+22	-12	+30	-21	+16	-35	-3	-54
250	304,8	+26	-16	+35	-27	+21	-41	-1	-63
304,8	315	+26	+10	+35	-1	+21	-15	-1	-37
315	400	+30	+5	+40	-6	+24	-22	-1	-47
400	500	+35	+1	+45	-12	+28	-29	0	-57
500	609,6	+24	-19	+24	-45	+6	-63	-28	-97
609,6	630	+24	+6	+24	-20	+6	-38	-28	-72
630	800	+45	-4	+45	-34	+25	-54	-13	-92
800	914,4	+66	-14	+66	-48	+44	-70	0	-114
914,4	1 000	+66	+12	+66	-22	+44	-44	0	-88
1 000	1 219,2	+85	-4	+85	-43	+59	-69	+5	-123

Metric single row taper roller bearings
d 15 – 32 mm

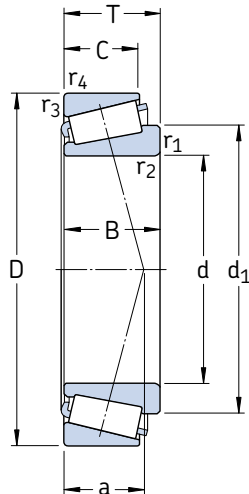

Principal dimensions			Basic load ratings		Fatigue load limit P_u	Speed ratings		Mass	Designation	Dimension Series to ISO 355 (ABMA)
d	D	T	dynamic	static		Refer-ence speed	Limiting speed			
			C	C_0						
mm			kN		kN	r/min		kg	–	–
15	42	14,25	22,4	20	2,08	13 000	18 000	0,095	30302 J2	2FB
17	40	13,25	19	18,6	1,83	13 000	18 000	0,075	30203 J2	2DB
	47	15,25	28,1	25	2,75	12 000	16 000	0,13	30303 J2	2FB
	47	20,25	34,7	33,5	3,65	11 000	16 000	0,17	32303 J2/Q	2FD
20	42	15	24,2	27	2,7	12 000	16 000	0,097	32004 X/Q	3CC
	47	15,25	27,5	28	3	11 000	15 000	0,12	30204 J2/Q	2DB
	52	16,25	34,1	32,5	3,6	11 000	14 000	0,17	30304 J2/Q	2FB
	52	22,25	44	45,5	5	10 000	14 000	0,23	32304 J2/Q	2FD
22	44	15	25,1	29	2,85	11 000	15 000	0,10	320/22 X	3CC
25	47	15	27	32,5	3,25	11 000	14 000	0,11	32005 X/Q	4CC
	52	16,25	30,8	33,5	3,45	10 000	13 000	0,15	30205 J2/Q	3CC
	52	19,25	35,8	44	4,65	9 500	13 000	0,19	32205 BJ2/Q	5CD
	52	22	54	56	6	10 000	13 000	0,23	* 33205/Q	2DE
28	62	18,25	44,6	43	4,75	9 000	12 000	0,26	30305 J2	2FB
	62	18,25	38	40	4,4	7 500	11 000	0,26	31305 J2	7FB
	62	25,25	60,5	63	7,1	8 000	12 000	0,36	32305 J2	2FD
30	52	16	36,5	38	4	10 000	13 000	0,15	* 320/28 X/Q	4CC
	58	17,25	38	41,5	4,4	9 000	12 000	0,25	302/28 J2	–
	58	20,25	41,8	50	5,5	8 500	12 000	0,25	322/28 BJ2/Q	5DD
32	55	17	35,8	44	4,55	9 000	12 000	0,17	32006 X/Q	4CC
	62	17,25	40,2	44	4,8	8 500	11 000	0,23	30206 J2/Q	3DB
	62	21,25	50,1	57	6,3	8 500	11 000	0,28	32206 J2/Q	3DC
	62	21,25	49,5	58,5	6,55	8 000	11 000	0,30	32206 BJ2/QCL7CVA606	5DC
	62	25	64,4	76,5	8,5	7 500	11 000	0,37	33206/Q	2DE
	72	20,75	56,1	56	6,4	7 500	10 000	0,39	30306 J2/Q	2FB
32	72	20,75	47,3	50	5,7	6 700	9 500	0,39	31306 J2/Q	7FB
	72	28,75	76,5	85	9,65	7 000	10 000	0,55	32306 J2/Q	2FD
	53	14,5	27	35,5	3,65	9 000	12 000	0,11	JL 26749 F/710	(L 26700)
	58	17	36,9	46,5	4,8	8 500	11 000	0,19	320/32 X/Q	4CC

* SKF Explorer bearing

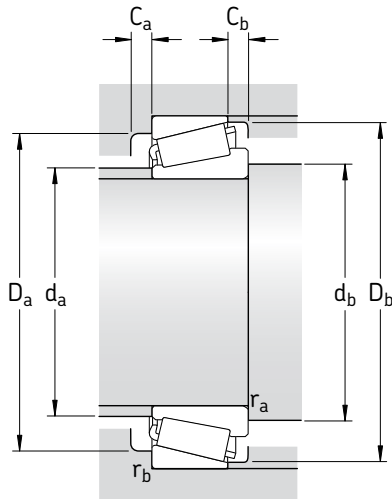

Dimensions							Abutment and fillet dimensions										Calculation factors		
d	d_1 ~	B	C	$r_{1,2}$ min	$r_{3,4}$ min	a	d_a max	d_b min	D_a min	D_a max	D_b min	C_a min	C_b min	r_a max	r_b max	e	Y	Y_0	
mm							mm										-		
15	27,7	13	11	1	1	9	22	21	36	36	38	2	3	1	1	0,28	2,1	1,1	
17	28	12	11	1	1	10	23	23	34	34	37	2	2	1	1	0,35	1,7	0,9	
	30,4	14	12	1	1	10	25	23	40	41	42	2	3	1	1	0,28	2,1	1,1	
	30,7	19	16	1	1	12	24	23	39	41	43	3	4	1	1	0,28	2,1	1,1	
20	31,1	15	12	0,6	0,6	10	25	25	36	37	39	2	3	0,6	0,6	0,37	1,6	0,9	
	33,2	14	12	1	1	11	27	26	40	41	43	2	3	1	1	0,35	1,7	0,9	
	34,3	15	13	1,5	1,5	11	28	27	44	45	47	2	3	1,5	1,5	0,3	2	1,1	
	34,5	21	18	1,5	1,5	14	27	27	43	45	47	3	4	1,5	1,5	0,3	2	1,1	
22	33,3	15	11,5	0,6	0,6	11	27	27	38	39	41	3	3,5	0,6	0,6	0,40	1,5	0,8	
25	36,5	15	11,5	0,6	0,6	11	30	30	40	42	44	3	3,5	0,6	0,6	0,43	1,4	0,8	
	37,4	15	13	1	1	12	31	31	44	46	48	2	3	1	1	0,37	1,6	0,9	
	40,2	18	15	1	1	16	30	31	41	46	50	3	4	1	1	0,57	1,05	0,6	
	38,6	22	18	1	1	14	30	31	43	46	49	4	4	1	1	0,35	1,7	0,9	
	41,5	17	15	1,5	1,5	13	34	32	54	55	57	2	3	1,5	1,5	0,3	2	1,1	
45,8	17	13	1,5	1,5	20	34	32	47	55	59	3	5	1,5	1,5	0,83	0,72	0,4		
41,7	24	20	1,5	1,5	15	33	32	52	55	57	3	5	1,5	1,5	0,3	2	1,1		
28	40,3	16	12	1	1	12	34	34	45	46	49	3	4	1	1	0,43	1,4	0,8	
	41,8	16	14	1	1	13	35	34	50	52	54	2	3	1	1	0,37	1,6	0,9	
	43,9	19	16	1	1	17	33	34	46	52	55	3	4	1	1	0,57	1,05	0,6	
30	43	17	13	1	1	13	35	36	48	49	52	3	4	1	1	0,43	1,4	0,8	
	44,6	16	14	1	1	14	38	36	53	56	57	2	3	1	1	0,37	1,6	0,9	
	45,2	20	17	1	1	15	37	36	52	56	58	3	4	1	1	0,37	1,6	0,9	
	47,3	20	17	1	1	18	36	36	50	56	60	3	4	1	1	0,57	1,05	0,6	
	45,8	25	19,5	1	1	16	36	36	53	56	59	5	5,5	1	1	0,35	1,7	0,9	
	48,4	19	16	1,5	1,5	15	41	37	62	65	66	3	4,5	1,5	1,5	0,31	1,9	1,1	
52,7	19	14	1,5	1,5	22	40	37	55	65	68	3	6,5	1,5	1,5	0,83	0,72	0,4		
48,7	27	23	1,5	1,5	18	39	37	59	65	66	3	5,5	1,5	1,5	0,31	1,9	1,1		
32	43,6	15	11,5	3,5	1,3	11	38	43	47	47	50	2	3	3	1	0,33	1,8	1	
	45,6	17	13	1	1	14	38	38	50	52	55	3	4	1	1	0,46	1,3	0,7	

Metric single row taper roller bearings
d 35 – 40 mm

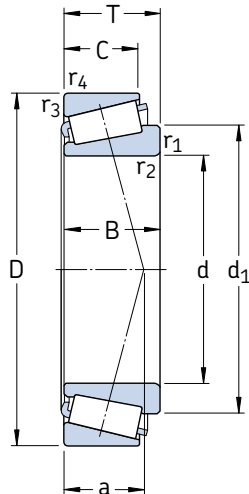

Principal dimensions			Basic load ratings		Fatigue load limit P_u	Speed ratings		Mass	Designation	Dimension Series to ISO 355 (ABMA)
d	D	T	dynamic	static		Refer-ence speed	Limiting speed			
mm			kN		kN	r/min		kg	–	–
35	62	18	49	54	5,85	8 500	11 000	0,22	* 32007 X/Q	4CC
	62	18	42,9	49	5,2	8 000	11 000	0,22	32007 J2/Q	–
	72	18,25	51,2	56	6,1	7 000	9 500	0,32	30207 J2/Q	3DB
	72	24,25	66	78	8,5	7 000	9 500	0,43	32207 J2/Q	3DC
	72	28	84,2	106	11,8	6 300	9 500	0,56	33207/Q	2DE
	80	22,75	72,1	73,5	8,3	6 700	9 000	0,52	30307 J2/Q	2FB
	80	22,75	61,6	67	7,8	6 000	8 500	0,52	31307 J2/Q	7FB
	80	32,75	95,2	106	12,2	6 300	9 000	0,73	32307 J2/Q	2FE
	80	32,75	93,5	114	13,2	6 000	8 500	0,80	32307 BJ2/Q	5FE
	37	80	32,75	93,5	114	13,2	6 000	8 500	0,85	32307/37 BJ2/Q
38	63	17	36,9	52	5,4	7 500	11 000	0,20	JL 69349 A/310/Q	(L 69300)
	63	17	36,9	52	5,4	7 500	11 000	0,20	JL 69349 X/310/Q	(L 69300)
	63	17	36,9	52	5,4	7 500	11 000	0,19	JL 69349/310/Q	(L 69300)
	63	17	36,9	52	5,4	7 500	11 000	0,19	JL 69345 F/310/Q	(L 69300)
	68	19	52,8	71	7,65	7 000	9 500	0,28	32008/38 X/Q	–
40	68	19	52,8	71	7,65	7 000	9 500	0,27	32008 X/Q	3CD
	68	19	52,8	71	7,65	7 000	9 500	0,27	32008 XTN9/Q	3CD
	75	26	79,2	104	11,4	6 700	9 000	0,51	33108/Q	2CE
	80	19,75	61,6	68	7,65	6 300	8 500	0,42	30208 J2/Q	3DB
	80	24,75	74,8	86,5	9,8	6 300	8 500	0,53	32208 J2/Q	3DC
	80	32	105	132	15	5 600	8 500	0,77	33208/QCL7C	2DE
	85	33	121	150	17,3	6 000	9 000	0,90	T2EE 040/QVB134	2EE
	90	25,25	85,8	95	10,8	6 000	8 000	0,72	30308 J2/Q	2FB
	90	25,25	85	81,5	9,5	5 600	7 500	0,72	* 31308 J2/QCL7C	7FB
	90	35,25	117	140	16	5 300	8 000	1,00	32308 J2/Q	2FD

* SKF Explorer bearing

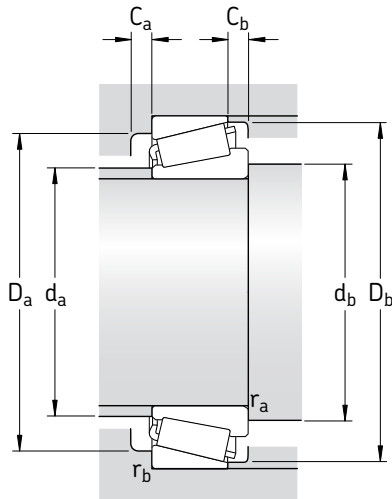

Dimensions							Abutment and fillet dimensions								Calculation factors			
d	d ₁ ~	B	C	r _{1,2} min	r _{3,4} min	a	d _a max	d _b min	D _a min	D _a max	D _b min	C _a min	C _b min	r _a max	r _b max	e	Y	Y ₀
mm							mm								-			
35	49,2	18	14	1	1	15	41	41	54	56	59	4	4	1	1	0,46	1,3	0,7
	49,5	18	15	1	1	16	41	41	53	56	59	2	3	1	1	0,44	1,35	0,8
	51,8	17	15	1,5	1,5	15	44	42	62	65	67	3	3	1,5	1,5	0,37	1,6	0,9
	52,4	23	19	1,5	1,5	17	43	42	61	65	67	3	5	1,5	1,5	0,37	1,6	0,9
	53,4	28	22	1,5	1,5	18	42	42	61	65	68	5	6	1,5	1,5	0,35	1,7	0,9
	54,5	21	18	2	1,5	16	46	44	70	71	74	3	4,5	2	1,5	0,31	1,9	1,1
	59,6	21	15	2	1,5	25	45	44	62	71	76	3	7,5	2	1,5	0,83	0,72	0,4
	54,8	31	25	2	1,5	20	44	44	66	71	74	4	7,5	2	1,5	0,31	1,9	1,1
	59,3	31	25	2	1,5	24	42	44	61	71	76	4	7,5	2	1,5	0,54	1,1	0,6
	37	54,8	31	25	2	1,5	20	44	44	66	71	4	7,5	2	1,5	0,54	1,1	0,6
38	52,2	17	13,5	1,3	1,3	14	44	44	55	56,5	60	3	3,5	1	1	0,43	1,4	0,8
	52,2	17	13,5	2,3	1,3	14	44	47	55	56,5	60	3	3,5	2	1	0,43	1,4	0,8
	52,2	17	13,5	3,6	1,3	14	44	50	55	56,5	60	3	3,5	3,5	1	0,43	1,4	0,8
	52,2	19	13,5	3,6	1,3	14	44	50	55	56,5	60	3	3,5	3,5	1	0,43	1,4	0,8
	54,2	19	14,5	1	1	15	46	44	60	62	65	4	4,5	1	1	0,37	1,6	0,9
40	54,2	19	14,5	1	1	15	46	46	60	62	65	4	4,5	1	1	0,37	1,6	0,9
	54,2	19	14,5	1	1	15	46	46	60	62	65	4	4,5	1	1	0,37	1,6	0,9
	57,5	26	20,5	1,5	1,5	18	47	47	65	68	71	4	5,5	1,5	1,5	0,35	1,7	0,9
	57,5	18	16	1,5	1,5	16	49	47	69	73	74	3	3,5	1,5	1,5	0,37	1,6	0,9
	58,4	23	19	1,5	1,5	19	49	47	68	73	75	3	5,5	1,5	1,5	0,37	1,6	0,9
	59,7	32	25	1,5	1,5	21	47	47	67	73	76	5	7	1,5	1,5	0,35	1,7	0,9
	61,2	32,5	28	2,5	2	22	48	50	70	75	80	5	5	2	2	0,35	1,7	0,9
	62,5	23	20	2	1,5	19	53	49	77	81	82	3	5	2	1,5	0,35	1,7	0,9
	67,1	23	17	2	1,5	28	51	49	71	81	86	3	8	2	1,5	0,83	0,72	0,4
	62,9	33	27	2	1,5	23	51	49	73	81	82	3	8	2	1,5	0,35	1,7	0,9

Metric single row taper roller bearings
d 45 – 50 mm

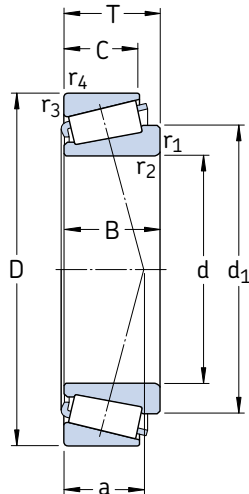

Principal dimensions			Basic load ratings		Fatigue load limit P_u	Speed ratings		Mass	Designation	Dimension Series to ISO 355 (ABMA)
d	D	T	dynamic	static		Refer- ence speed	Limiting speed			
mm			C	C_0	kN	r/min	kg	–	–	
45	75	20	58,3	80	8,8	6 300	8 500	0,34	32009 X/Q	3CC
	80	26	96,5	114	12,9	6 700	8 000	0,56	* 33109/Q	3CE
	85	20,638	70,4	81,5	9,3	6 000	8 500	0,50	358 X/354 X/Q	(355)
	85	20,75	66	76,5	8,65	6 000	8 000	0,48	30209 J2/Q	3DB
	85	24,75	91,5	98	11	6 300	8 000	0,58	* 32209 J2/Q	3DC
	85	32	108	143	16,3	5 300	7 500	0,82	33209/Q	3DE
	90	24,75	82,5	104	12,2	5 300	8 000	0,65	32210/45 BJ2/QVB022	–
	95	29	89,7	112	12,7	4 800	7 000	0,92	T7FC 045/HN3QCL7C	7FC
	95	36	147	186	20,8	5 300	8 000	1,20	T2ED 045	2ED
	100	27,25	108	120	14,3	5 300	7 000	0,97	30309 J2/Q	2FB
	100	27,25	106	102	12,5	5 000	6 700	0,95	* 31309 J2/QCL7C	7FB
	100	38,25	140	170	20,4	4 800	7 000	1,35	32309 J2/Q	2FD
	100	38,25	134	176	20	4 800	6 700	1,45	32309 BJ2/QCL7C	5FD
	46	75	18	50,1	71	7,65	6 300	9 500	0,30	LM 503349/310/QCL7C
50	80	20	60,5	88	9,65	6 000	8 000	0,37	32010 X/Q	3CC
	80	20	60,5	88	9,65	6 000	8 000	0,37	32010 X/QCL7CVB026	3CC
	80	24	69,3	102	11,4	6 000	8 000	0,45	33010/Q	2CE
	82	21,5	72,1	100	11	6 000	8 500	0,43	JLM 104948 AA/910 AA/Q	(LM 104900)
	85	26	85,8	122	13,4	5 600	7 500	0,59	33110/Q	3CE
	90	21,75	76,5	91,5	10,4	5 600	7 500	0,54	30210 J2/Q	3DB
	90	24,75	82,5	100	11,4	5 600	7 500	0,61	32210 J2/Q	3DC
	90	28	106	140	16	5 300	8 000	0,75	JM 205149/110/Q	(M 205100)
	90	28	106	140	16	5 300	8 000	0,75	JM 205149/110 A/Q	(M 205100)
	90	32	114	160	18,3	5 000	7 000	0,90	33210/Q	3DE
	100	36	154	200	22,4	5 000	7 500	1,30	T2ED 050/Q	2ED
	105	32	108	137	16	4 300	6 300	1,20	T7FC 050/QCL7C	7FC
	110	29,25	143	140	16,6	5 300	6 300	1,25	* 30310 J2/Q	2FB
	110	29,25	122	120	14,3	4 500	6 000	1,20	* 31310 J2/QCL7C	7FB
110	42,25	172	212	24	4 300	6 300	1,80	32310 J2/Q	2FD	
110	42,25	172	212	24	4 300	6 300	1,80	32310 TN9	2FD	
110	42,25	183	216	24,5	4 500	6 000	1,85	* 32310 BJ2/QCL7C	5FD	

* SKF Explorer bearing

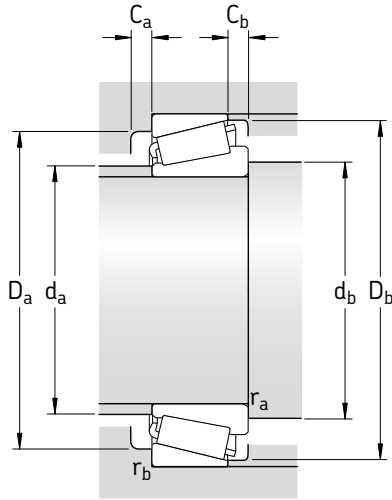

Dimensions							Abutment and fillet dimensions									Calculation factors		
d	d ₁	B	C	r _{1,2}	r _{3,4}	a	d _a	d _b	D _a	D _a	D _b	C _a	C _b	r _a	r _b	e	Y	Y ₀
							mm									-		
45	60,4	20	15,5	1	1	16	52	51	67	69	72	4	4,5	1	1	0,4	1,5	0,8
	62,7	26	20,5	1,5	1,5	19	52	52	69	73	77	4	5,5	1,5	1,5	0,37	1,6	0,9
	62,4	21,692	17,462	2	1,5	16	55	53	76	77	80	3	3	2	1,5	0,31	1,9	1,1
	63	19	16	1,5	1,5	18	54	52	74	78	80	3	4,5	1,5	1,5	0,4	1,5	0,8
	64	23	19	1,5	1,5	20	54	52	73	78	80	3	5,5	1,5	1,5	0,4	1,5	0,8
	65,2	32	25	1,5	1,5	22	52	52	72	78	81	5	7	1,5	1,5	0,4	1,5	0,8
	68,5	23	19	1,5	0,3	21	58	52	78	87	85	3	5,5	1,5	0,3	0,6	1	0,6
	74	26,5	20	2,5	2,5	32	54	56	71	83	91	3	9	2	2	0,88	0,68	0,4
	68,5	35	30	2,5	2,5	23	55	56	80	83	89	6	6	2	2	0,33	1,8	1
	70,1	25	22	2	1,5	21	59	53	86	91	92	3	5	2	1,5	0,35	1,7	0,9
	74,7	25	18	2	1,5	31	57	53	79	91	95	4	9	2	1,5	0,83	0,72	0,4
	70,4	36	30	2	1,5	25	57	53	82	91	93	4	8	2	1,5	0,35	1,7	0,9
74,8	36	30	2	1,5	30	55	53	76	91	94	5	8	2	1,5	0,54	1,1	0,6	
46	60,4	18	14	2,3	1,5	16	53	55	67	67,5	71	2	4	2	1,5	0,4	1,5	0,8
50	65,6	20	15,5	1	1	18	57	56	72	74	77	4	4,5	1	1	0,43	1,4	0,8
	65,6	20	15,5	3	1	18	57	62	72	74	77	4	4,5	2,5	1	0,43	1,4	0,8
	64,9	24	19	1	1	17	56	56	72	74	76	4	5	1	1	0,31	1,9	1,1
	65,1	21,5	17	3,6	1,2	16	57	62	74	76	78	4	4,5	3,4	1,2	0,3	2	1,1
	67,9	26	20	1,5	1,5	20	57	57	74	78	82	4	6	1,5	1,5	0,4	1,5	0,8
	67,9	20	17	1,5	1,5	19	58	57	79	83	85	3	4,5	1,5	1,5	0,43	1,4	0,8
	68,5	23	19	1,5	1,5	21	58	57	78	83	85	3	5,5	1,5	1,5	0,43	1,4	0,8
	68,7	28	23	3	2,5	20	58	64	78	78	85	5	5	2,5	2	0,33	1,8	1
	68,7	28	23	3	0,8	20	58	64	78	85	85	5	5	2,5	0,6	0,33	1,8	1
	70,7	32	24,5	1,5	1,5	23	57	57	77	83	87	5	7,5	1,5	1,5	0,4	1,5	0,8
	73,5	35	30	2,5	2,5	25	59	60	84	88	94	6	6	2	2	0,35	1,7	0,9
	81	29	22	3	3	36	60	62	78	91	100	4	10	2,5	2,5	0,88	0,68	0,4
77,2	27	23	2,5	2	23	65	60	95	100	102	4	6	2	2	0,35	1,7	0,9	
81,5	27	19	2,5	2	34	62	60	87	100	104	4	10	2	2	0,83	0,72	0,4	
77,7	40	33	2,5	2	27	63	60	90	100	102	5	9	2	2	0,35	1,7	0,9	
77,7	40	33	2,5	2	27	63	60	90	100	102	5	9	2	2	0,35	1,7	0,9	
82,9	40	33	2,5	2	34	62	60	83	100	103	5	9	2	2	0,54	1,1	0,6	

Metric single row taper roller bearings
d 55 – 60 mm

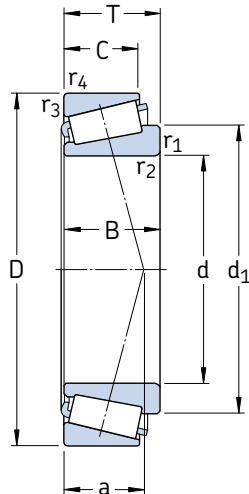

Principal dimensions			Basic load ratings		Fatigue load limit P_u	Speed ratings		Mass	Designation	Dimension Series to ISO 355
d	D	T	dynamic	static		Reference speed	Limiting speed			
mm			C	C_0	kN	r/min	kg	–	–	
55	90	23	80,9	116	12,9	5 300	7 000	0,55	32011 X/Q	3CC
	90	27	104	137	15,3	5 600	7 000	0,67	* 33011/Q	2CE
	95	30	110	156	17,6	5 000	6 700	0,86	33111/Q	3CE
	100	22,75	104	106	12	5 300	6 700	0,70	* 30211 J2/Q	3DB
	100	26,75	106	129	15	5 000	6 700	0,83	32211 J2/Q	3DC
	100	35	138	190	21,6	4 500	6 300	1,20	33211/Q	3DE
	110	39	179	232	26	4 500	6 700	1,70	T2ED 055/QCLN	2ED
	115	34	125	163	19,3	4 000	5 600	1,60	T7FC 055/QCL7C	7FC
	120	31,5	166	163	19,3	4 800	5 600	1,55	* 30311 J2/Q	2FB
	120	31,5	121	137	16,6	3 800	5 600	1,55	31311 J2/QCL7C	7FB
120	45,5	198	250	28,5	4 000	5 600	2,30	32311 J2	2FD	
120	45,5	216	260	30	4 300	5 600	2,50	* 32311 BJ2/QCL7C	5FD	
60	95	23	95	122	13,4	5 300	6 700	0,59	* 32012 X/QCL7C	4CC
	95	24	84,2	132	15	4 800	7 000	0,63	JLM 508748/710/Q	2CE
	95	27	106	143	16	5 300	6 700	0,71	* 33012/Q	2CE
	100	30	117	170	19,6	4 800	6 300	0,92	33112/Q	3CE
	110	23,75	112	114	13,2	5 000	6 000	0,88	* 30212 J2/Q	3EB
	110	29,75	125	160	18,6	4 500	6 000	1,15	32212 J2/Q	3EC
	110	38	168	236	26,5	4 000	6 000	1,60	33212/Q	3EE
	115	40	194	260	30	4 300	6 300	1,85	T2EE 060/Q	2EE
	125	37	154	204	24,5	3 600	5 300	2,05	T7FC 060/QCL7C	7FC
	130	33,5	168	196	23,6	4 000	5 300	1,95	30312 J2/Q	2FB
	130	33,5	145	166	20,4	3 600	5 300	1,90	31312 J2/QCL7C	7FB
	130	48,5	229	290	34	3 600	5 300	2,85	32312 J2/Q	2FD
	130	48,5	220	305	35,5	3 600	5 000	2,80	32312 BJ2/QCL7C	5FD

* SKF Explorer bearing

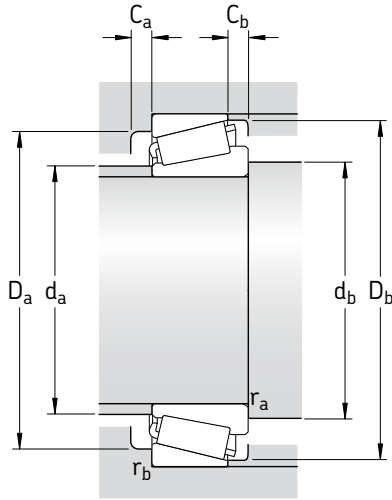

Dimensions							Abutment and fillet dimensions								Calculation factors			
d	d ₁	B	C	r _{1,2}	r _{3,4}	a	d _a	d _b	D _a	D _a	D _b	C _a	C _b	r _a	r _b	e	Y	Y ₀
							mm								-			
55	73,2	23	17,5	1,5	1,5	20	63	62	81	83	86	4	5,5	1,5	1,5	0,4	1,5	0,8
	72,9	27	21	1,5	1,5	19	63	62	81	83	86	5	6	1,5	1,5	0,31	1,9	1,1
	75,1	30	23	1,5	1,5	22	63	62	83	88	91	5	7	1,5	1,5	0,37	1,6	0,9
	74,6	21	18	2	1,5	20	64	64	88	93	94	4	4,5	2	1,5	0,4	1,5	0,8
	75,2	25	21	2	1,5	22	64	64	87	93	95	4	5,5	2	1,5	0,4	1,5	0,8
	77,6	35	27	2	1,5	25	63	64	85	93	96	6	8	2	1,5	0,4	1,5	0,8
	81	39	32	2,5	2,5	27	66	65	93	99	104	7	7	2	2	0,35	1,7	0,9
	90	31	23,5	3	3	39	66	67	86	103	109	4	10,5	2,5	2,5	0,88	0,68	0,4
	84	29	25	2,5	2	24	71	65	104	112	111	4	6,5	2	2	0,35	1,7	0,9
	88,4	29	21	2,5	2	37	68	65	94	112	113	4	10,5	2	2	0,83	0,72	0,4
	84,6	43	35	2,5	2	29	68	65	99	112	111	5	10,5	2	2	0,35	1,7	0,9
	90,5	43	35	2,5	2	36	67	65	91	112	112	5	10,5	2	2	0,54	1,1	0,6
60	77,8	23	17,5	1,5	1,5	21	67	67	85	88	91	4	5	1,5	1,5	0,43	1,4	0,8
	78,4	24	19	5	2,5	21	68	76	84	85	91	4	5	4	2	0,4	1,5	0,8
	77,1	27	21	1,5	1,5	20	67	67	85	88	90	5	6	1,5	1,5	0,33	1,8	1
	80,4	30	23	1,5	1,5	23	67	67	88	93	96	5	7	1,5	1,5	0,4	1,5	0,8
	81,5	22	19	2	1,5	22	70	68	96	103	103	4	4,5	2	1,5	0,4	1,5	0,8
	81,9	28	24	2	1,5	24	69	68	95	103	104	4	5,5	2	1,5	0,4	1,5	0,8
	85,3	38	29	2	1,5	27	69	68	93	103	105	6	9	2	1,5	0,4	1,5	0,8
	85	39	33	2,5	2,5	28	70	71	98	104	109	6	7	2	2	0,33	1,8	1
	97	33,5	26	3	3	41	72	72	94	111	119	4	11	2,5	2,5	0,83	0,72	0,4
	91,9	31	26	3	2,5	26	77	72	112	118	120	5	7,5	2,5	2	0,35	1,7	0,9
	95,9	31	22	3	2,5	39	74	72	103	118	123	5	11,5	2,5	2	0,83	0,72	0,4
	91,7	46	37	3	2,5	31	74	72	107	118	120	6	11,5	2,5	2	0,35	1,7	0,9
	98,1	46	37	3	2,5	38	73	72	99	118	122	6	11,5	2,5	2	0,54	1,1	0,6

Metric single row taper roller bearings
d 65 – 70 mm

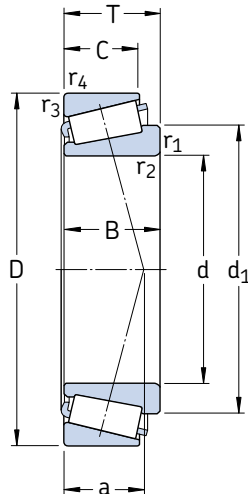

Principal dimensions			Basic load ratings		Fatigue load limit P_u	Speed ratings		Mass	Designation	Dimension Series to ISO 355 (ABMA)
d	D	T	dynamic	static		Reference speed	Limiting speed			
mm			kN		kN	r/min		kg	–	–
65	100	23	96,5	127	14	5 000	6 000	0,63	* 32013 X/Q	4CC
	100	27	110	153	17,3	5 000	6 300	0,78	* 33013/Q	2CE
	110	28	123	183	21,2	4 300	6 300	1,05	JM 511946/910/Q	(M 511900)
	110	31	138	193	22,4	4 300	6 300	1,15	T2DD 065/Q	2DD
	110	34	142	208	24	4 300	5 600	1,30	33113/Q	3DE
	120	24,75	132	134	16,3	4 500	5 600	1,15	* 30213 J2/Q	3EB
	120	32,75	151	193	22,8	4 000	5 600	1,50	32213 J2/Q	3EC
	120	41	194	270	30,5	3 800	5 300	2,05	33213/Q	3EE
	120	41	194	270	30,5	3 800	5 300	2,05	33213 TN9/Q	3EE
	130	37	157	216	25,5	3 400	5 000	2,20	T7FC 065/QCL7C	7FC
	140	36	194	228	27,5	3 600	4 800	2,40	30313 J2/Q	2GB
	140	36	165	193	23,6	3 200	4 800	2,35	31313 J2/QCL7C	7GB
	140	51	264	335	40	3 400	4 800	3,45	32313 J2/Q	2GD
	140	51	246	345	40,5	3 200	4 800	3,35	32313 BJ2/QU4CL7CVQ267	5GD
70	110	25	101	153	17,3	4 300	5 600	0,84	32014 X/Q	4CC
	110	31	130	196	22,8	4 300	5 600	1,10	33014	2CE
	120	37	172	250	30	4 000	5 300	1,70	33114/Q	3DE
	125	26,25	125	156	18	4 000	5 300	1,25	30214 J2/Q	3EB
	125	33,25	157	208	24,5	3 800	5 300	1,60	32214 J2/Q	3EC
	125	41	201	285	32,5	3 600	5 000	2,10	33214/Q	3EE
	130	43	233	325	38	3 800	5 600	2,45	T2ED 070/QCLNVB061	2ED
	140	39	176	240	27,5	3 200	4 500	2,65	T7FC 070/QCL7C	7FC
	150	38	220	260	31	3 400	4 500	2,90	30314 J2/Q	2GB
	150	38	187	220	27	3 000	4 500	2,95	31314 J2/QCL7C	7GB
	150	54	297	380	45	3 200	4 500	4,30	32314 J2/Q	2GD
	150	54	281	400	46,5	3 000	4 300	4,25	32314 BJ2/QCL7C	5GD

* SKF Explorer bearing

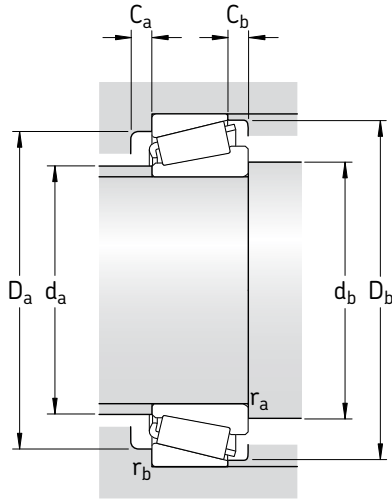

Dimensions							Abutment and fillet dimensions							Calculation factors				
d	d ₁	B	C	r _{1,2} min	r _{3,4} min	a	d _a max	d _b min	D _a min	D _a max	D _b min	C _a min	C _b min	r _a max	r _b max	e	Y	Y ₀
mm							mm							-				
65	83,3	23	17,5	1,5	1,5	22	72	72	90	93	97	4	5,5	1,5	1,5	0,46	1,3	0,7
	82,5	27	21	1,5	1,5	21	72	72	89	93	96	5	6	1,5	1,5	0,35	1,7	0,9
	87,8	28	22,5	3	2,5	24	75	77	96	98	104	5	5,5	2,5	2	0,4	1,5	0,8
	85,6	31	25	2	2	23	74	75	97	100	105	5	6	2	2	0,35	1,7	0,9
	87,9	34	26,5	1,5	1,5	26	74	72	96	103	106	6	7,5	1,5	1,5	0,4	1,5	0,8
	89	23	20	2	1,5	23	78	74	106	113	113	4	4,5	2	1,5	0,4	1,5	0,8
	90,3	31	27	2	1,5	27	76	74	104	113	115	4	5,5	2	1,5	0,4	1,5	0,8
	92,1	41	32	2	1,5	29	75	74	102	113	115	6	9	2	1,5	0,4	1,5	0,8
	92,1	41	32	2	1,5	29	75	74	102	113	115	6	9	2	1,5	0,4	1,5	0,8
	102	33,5	26	3	3	44	77	77	98	116	124	4	11	2,5	2,5	0,88	0,68	0,4
98,6	33	28	3	2,5	28	84	77	122	128	130	5	8	2,5	2	0,35	1,7	0,9	
103	33	23	3	2,5	42	80	77	111	128	132	5	13	2,5	2	0,83	0,72	0,4	
99,2	48	39	3	2,5	33	80	77	117	128	130	6	12	2,5	2	0,35	1,7	0,9	
105	48	39	3	2,5	41	79	77	107	128	131	6	12	2,5	2	0,54	1,1	0,6	
70	89,8	25	19	1,5	1,5	23	78	77	98	103	105	5	6	1,5	1,5	0,43	1,4	0,8
	88,8	31	25,5	1,5	1,5	23	78	77	99	103	105	5	5,5	1,5	1,5	0,28	2,1	1,1
	94,8	37	29	2	1,5	28	80	79	104	112	115	6	8	2	1,5	0,37	1,6	0,9
	93,9	24	21	2	1,5	25	82	78	110	115	118	4	5	2	1,5	0,43	1,4	0,8
	95	31	27	2	1,5	28	80	78	108	115	119	4	6	2	1,5	0,43	1,4	0,8
	97,2	41	32	2	1,5	30	79	78	107	115	120	6	9	2	1,5	0,4	1,5	0,8
	98	42	35	8	2,5	30	81	98	111	118	123	7	8	7	2	0,33	1,8	1
	110	35,5	27	3	3	47	82	82	106	126	133	5	12	2,5	2,5	0,88	0,68	0,4
	105	35	30	3	2,5	29	90	82	130	138	140	5	8	2,5	2	0,35	1,7	0,9
	110	35	25	3	2,5	45	85	82	118	138	141	5	13	2,5	2	0,83	0,72	0,4
106	51	42	3	2,5	36	86	82	125	138	140	6	12	2,5	2	0,35	1,7	0,9	
113	51	42	3	2,5	44	85	82	115	138	141	7	12	2,5	2	0,54	1,1	0,6	

Metric single row taper roller bearings
d 75 – 80 mm

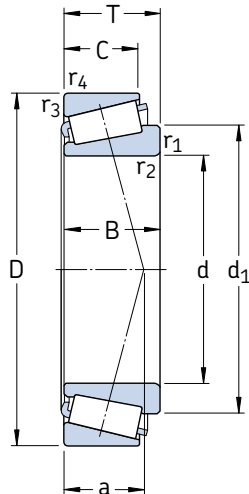

Principal dimensions			Basic load ratings		Fatigue load limit P_u	Speed ratings		Mass	Designation	Dimension Series to ISO 355 (ABMA)
d	D	T	dynamic	static C_0		Refer-ence speed	Limiting speed			
mm			kN		kN	r/min		kg	–	–
75	105	20	70,4	116	13,2	4 300	6 300	0,52	32915 TN9/QVG900	2BC
	115	25	106	163	18,6	4 000	5 300	0,90	32015 X/Q	4CC
	115	31	134	228	26	4 000	5 300	1,15	33015/Q	2CE
	120	31	138	216	25	3 800	5 600	1,30	JM 714249/210/Q	(M 714200)
	125	37	176	265	31,5	3 800	5 000	1,80	33115/Q	3DE
	130	27,25	140	176	20,4	3 800	5 000	1,40	30215 J2/Q	4DB
	130	33,25	161	212	24,5	3 600	5 000	1,70	32215 J2/Q	4DC
	130	41	209	300	34	3 400	4 800	2,25	33215/Q	3EE
	145	52	297	450	51	3 400	4 800	3,95	T3FE 075/QVB481	3FE
	150	42	201	280	31	3 000	4 300	3,25	T7FC 075/QCL7C	7FC
	160	40	246	290	34	3 200	4 300	3,45	30315 J2/Q	2GB
	160	40	209	245	29	2 800	4 300	3,50	31315 J2/QCL7C	7GB
	160	58	336	440	51	3 000	4 300	5,20	32315 J2	2GD
	160	58	336	475	55	2 800	4 000	5,55	32315 BJ2/QCL7C	5GD
80	125	29	138	216	24,5	3 600	5 000	1,30	32016 X/Q	3CC
	125	36	168	285	32	3 600	5 000	1,65	33016/Q	2CE
	130	35	176	275	32,5	3 600	5 300	1,70	JM 515649/610/Q	(M515600)
	130	37	179	280	32,5	3 600	4 800	1,90	33116/Q	3DE
	130	37	179	280	32,5	3 600	4 800	1,90	33116 TN9/Q	3DE
	140	28,25	151	183	21,2	3 400	4 800	1,60	30216 J2/Q	3EB
	140	35,25	187	245	28,5	3 400	4 500	2,05	32216 J2/Q	3EC
	140	46	251	375	41,5	3 200	4 500	2,90	33216/Q	3EE
	160	45	229	315	35,5	2 800	4 000	3,95	T7FC 080/QCL7C	7FC
	170	42,5	270	320	38	3 000	4 300	4,10	30316 J2	2GB
	170	42,5	224	265	32	2 800	4 000	4,05	31316 J1/QCL7C	7GB
	170	61,5	380	500	57	3 000	4 300	6,20	32316 J2	2GD

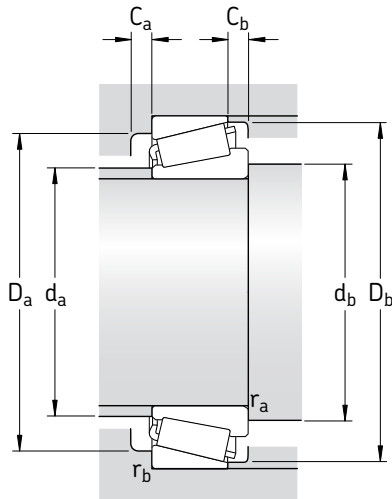

Dimensions							Abutment and fillet dimensions								Calculation factors			
d	d ₁	B	C	r _{1,2}	r _{3,4}	a	d _a	d _b	D _a	D _a	D _b	C _a	C _b	r _a	r _b	e	Y	Y ₀
							mm								-			
75	89,2	20	16	1	1	19	81	82	98	98	101	4	4	1	1	0,33	1,8	1
	95,1	25	19	1,5	1,5	25	83	82	103	108	110	5	6	1,5	1,5	0,46	1,3	0,7
	95	31	25,5	1,5	1,5	23	84	82	104	108	110	6	5,5	1,5	1,5	0,3	2	1,1
	98,1	29,5	25	3	2,5	28	84	87	104	110	115	5	6	2,5	2	0,44	1,35	0,8
	100	37	29	2	1,5	29	84	84	109	117	120	6	8	2	1,5	0,4	1,5	0,8
	99,2	25	22	2	1,5	27	86	84	115	122	124	4	5	2	1,5	0,43	1,4	0,8
	100	31	27	2	1,5	29	85	84	114	122	125	4	6	2	1,5	0,43	1,4	0,8
	102	41	31	2	1,5	32	84	84	111	122	125	6	10	2	1,5	0,43	1,4	0,8
	111	51	43	5	3	39	88	95	117	131	138	7	9	4	2,5	0,43	1,4	0,8
	118	38	29	3	3	50	88	87	114	136	143	5	13	2,5	2,5	0,88	0,68	0,4
	112	37	31	3	2,5	31	96	87	139	148	149	5	9	2,5	2	0,35	1,7	0,9
	116	37	26	3	2,5	48	91	87	127	148	151	6	14	2,5	2	0,83	0,72	0,4
113	55	45	3	2,5	38	92	87	133	148	149	7	13	2,5	2	0,35	1,7	0,9	
120	55	45	3	2,5	46	90	87	124	148	151	7	13	2,5	2	0,54	1,1	0,6	
80	103	29	22	1,5	1,5	27	90	87	112	117	120	6	7	1,5	1,5	0,43	1,4	0,8
	102	36	29,5	1,5	1,5	26	90	87	112	117	119	6	6,5	1,5	1,5	0,28	2,1	1,1
	105	38	31,5	3	2,5	29	90	91	114	120	124	5	6,5	2,5	2	0,4	1,5	0,8
	105	37	29	2	1,5	30	89	89	114	122	126	6	8	2	1,5	0,43	1,4	0,8
	105	37	29	2	1,5	30	89	89	114	122	126	6	8	2	1,5	0,43	1,4	0,8
	105	26	22	2,5	2	28	92	90	124	130	132	4	6	2	2	0,43	1,4	0,8
	106	33	28	2,5	2	30	91	90	122	130	134	5	7	2	2	0,43	1,4	0,8
	110	46	35	2,5	2	35	89	90	119	130	135	7	11	2	2	0,43	1,4	0,8
	125	41	31	3	3	53	94	92	121	146	152	5	14	2,5	2,5	0,88	0,68	0,4
	120	39	33	3	2,5	33	102	92	148	158	159	5	9,5	2,5	2	0,35	1,7	0,9
	124	39	27	3	2,5	52	97	92	134	158	159	6	15,5	2,5	2	0,83	0,72	0,4
	120	58	48	3	2,5	41	98	92	142	158	159	7	13,5	2,5	2	0,35	1,7	0,9

Metric single row taper roller bearings
d 85 – 95 mm

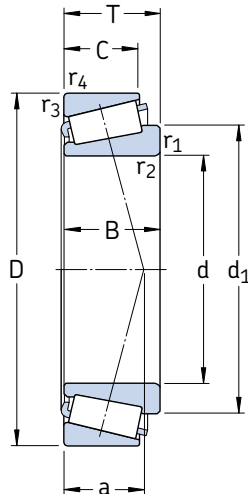

Principal dimensions			Basic load ratings		Fatigue load limit P_u	Speed ratings		Mass	Designation	Dimension Series to ISO 355 (ABMA)
d	D	T	dynamic	static C_0		Reference speed	Limiting speed			
mm			kN		kN	r/min		kg	–	–
85	130	29	140	224	25,5	3 400	4 800	1,35	32017 X/Q	4CC
	130	36	183	310	34,5	3 600	4 800	1,75	33017/Q	2CE
	140	41	220	340	38	3 400	4 500	2,45	33117/Q	3DE
	150	30,5	176	220	25,5	3 200	4 300	2,05	30217 J2/Q	3EB
	150	38,5	212	285	33,5	3 200	4 300	2,60	32217 J2/Q	3EC
	150	49	286	430	48	3 000	4 300	3,70	33217/Q	3EE
	180	44,5	303	365	40,5	2 800	4 000	4,85	30317 J2	2GB
	180	44,5	242	285	33,5	2 600	3 800	4,60	31317 J2	7GB
	180	63,5	402	530	60	2 800	4 000	6,85	32317 J2	2GD
	180	63,5	391	560	62	2 800	4 000	7,50	32317 BJ2	5GD
90	140	32	168	270	31	3 200	4 300	1,75	32018 X/Q	3CC
	140	39	216	355	39	3 200	4 500	2,20	33018/Q	2CE
	145	35	201	305	35,5	3 200	4 800	2,10	JM 718149 A/110/Q	(M 718100)
	150	45	251	390	43	3 000	4 300	3,10	33118/Q	3DE
	150	45	251	390	43	3 000	4 300	3,10	33118 TN9/Q	3DE
	160	32,5	194	245	28,5	3 000	4 000	2,55	30218 J2	3FB
	160	42,5	251	340	38	3 000	4 000	3,35	32218 J2/Q	3FC
	190	46,5	330	400	44	2 600	4 000	5,65	30318 J2	2GB
	190	46,5	264	315	36,5	2 400	3 400	5,90	31318 J2	7GB
	190	67,5	457	610	67	2 600	4 000	8,40	32318 J2	2GD
95	145	32	168	270	30,5	3 200	4 300	1,80	32019 X/Q	4CC
	145	39	220	375	40,5	3 200	4 300	2,30	33019/Q	2CE
	170	34,5	216	275	31,5	2 800	3 800	3,00	30219 J2	3FB
	170	45,5	281	390	43	2 800	3 800	4,05	32219 J2	3FC
	180	49	275	400	44	2 400	3 400	5,25	T7FC 095/CL7CVQ051	7FC
	200	49,5	330	390	42,5	2 600	3 400	6,70	30319	2GB
	200	49,5	292	355	39	2 400	3 400	6,95	31319 J2	7GB
	200	71,5	501	670	72	2 400	3 400	11,0	32319 J2	2GD

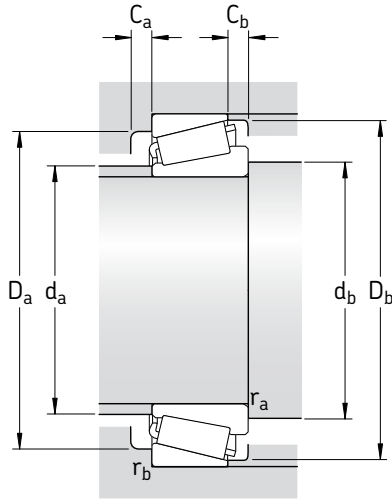

Dimensions							Abutment and fillet dimensions							Calculation factors					
d	d_1	B	C	$r_{1,2}$	$r_{3,4}$	a	d_a	d_b	D_a	D_a	D_b	C_a	C_b	r_a	r_b	e	Y	Y_0	
							max	min	min	max	min	min	min	max	max				
mm							mm							-					
85	108	29	22	1,5	1,5	28	94	92	117	122	125	6	7	1,5	1,5	0,44	1,35	0,8	
	107	36	29,5	1,5	1,5	26	94	92	118	122	125	6	6,5	1,5	1,5	0,3	2	1,1	
	112	41	32	2,5	2	32	95	95	122	130	135	7	9	2	2	0,4	1,5	0,8	
	112	28	24	2,5	2	30	97	95	132	140	141	5	6,5	2	2	0,43	1,4	0,8	
	113	36	30	2,5	2	33	97	95	130	140	142	5	8,5	2	2	0,43	1,4	0,8	
	117	49	37	2,5	2	37	96	95	128	140	144	7	12	2	2	0,43	1,4	0,8	
	126	41	34	4	3	35	107	99	156	166	167	6	10,5	3	2,5	0,35	1,7	0,9	
	131	41	28	4	3	55	103	99	143	166	169	6	16,5	3	2,5	0,83	0,72	0,4	
	126	60	49	4	3	42	103	99	150	166	167	7	14,5	3	2,5	0,35	1,7	0,9	
	135	60	49	4	3	52	102	99	138	166	169	7	14,5	3	2,5	0,54	1,1	0,6	
	90	115	32	24	2	1,5	30	100	98	125	132	134	6	8	2	1,5	0,43	1,4	0,8
		113	39	32,5	2	1,5	27	100	98	127	132	135	7	6,5	2	1,5	0,27	2,2	1,3
117		34	27	6	2,5	33	100	108	127	135	139	6	8	5	2	0,44	1,35	0,8	
120		45	35	2,5	2	35	101	101	130	140	144	7	10	2	2	0,4	1,5	0,8	
120		45	35	2,5	2	35	101	101	130	140	144	7	10	2	2	0,4	1,5	0,8	
118		30	26	2,5	2	31	104	101	140	150	150	5	6,5	2	2	0,43	1,4	0,8	
121		40	34	2,5	2	36	102	101	138	150	152	5	8,5	2	2	0,43	1,4	0,8	
132		43	36	4	3	36	113	105	165	176	176	6	10,5	3	2,5	0,35	1,7	0,9	
138		43	30	4	3	57	109	105	151	176	179	5	16,5	3	2,5	0,83	0,72	0,4	
133		64	53	4	3	44	109	105	157	176	177	7	14,5	3	2,5	0,35	1,7	0,9	
95		120	32	24	2	1,5	31	105	104	130	138	139	6	8	2	1,5	0,44	1,35	0,8
		118	39	32,5	2	1,5	28	104	104	131	138	139	7	6,5	2	1,5	0,28	2,1	1,1
	126	32	27	3	2,5	33	110	107	149	158	159	5	7,5	2,5	2	0,43	1,4	0,8	
	128	43	37	3	2,5	39	109	107	145	158	161	5	8,5	2,5	2	0,43	1,4	0,8	
	143	45	33	4	4	60	109	110	138	164	172	6	16	3	3	0,88	0,68	0,4	
	139	45	38	4	3	39	118	110	172	186	184	6	11,5	3	2,5	0,35	1,7	0,9	
	145	45	32	4	3	60	114	110	157	186	187	5	17,5	3	2,5	0,83	0,72	0,4	
	141	67	55	4	3	47	115	110	166	186	186	8	16,5	3	2,5	0,35	1,7	0,9	

Metric single row taper roller bearings
d 100 – 110 mm

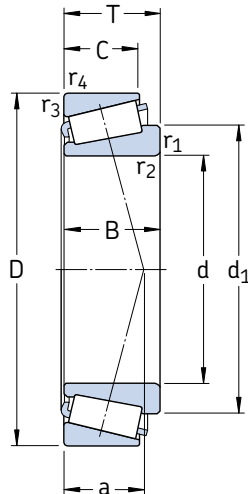

Principal dimensions			Basic load ratings		Fatigue load limit P_u	Speed ratings		Mass	Designation	Dimension Series to ISO 355 (ABMA)
d	D	T	dynamic	static		Refer-ence speed	Limiting speed			
mm			kN		kN	r/min		kg	–	–
100	140	25	119	204	22,4	3 200	4 800	1,15	32920/Q	2CC
	145	24	125	190	20,8	3 200	4 500	1,15	T4CB 100/Q	4CB
	150	32	172	280	31	3 000	4 000	1,90	32020 X/Q	4CC
	150	39	224	390	41,5	3 000	4 000	2,40	33020/Q	2CE
	157	42	246	400	42,5	3 000	4 300	2,90	HM 220149/110/Q	(HM 220100)
	160	41	246	390	41,5	2 800	4 300	3,00	JHM 720249/210/Q	(HM 720200)
	165	47	314	480	53	2 800	4 300	3,90	T2EE 100	2EE
	180	37	246	320	36	2 800	3 600	3,65	30220 J2	3FB
	180	49	319	440	48	2 600	3 600	4,90	32220 J2	3FC
	180	63	429	655	71	2 400	3 600	6,95	33220	3FE
105	215	51,5	402	490	53	2 400	3 200	8,05	30320 J2	2GB
	215	56,5	374	465	51	2 200	3 000	8,60	31320 XJ2/CL7CVQ051	7GB
	215	77,5	572	780	83	2 200	3 000	12,5	32320 J2	2GD
	160	35	201	335	37,5	2 800	3 800	2,40	32021 X/Q	4DC
	160	43	246	430	45,5	2 800	3 800	3,05	33021/Q	2DE
	190	39	270	355	40	2 600	3 400	4,25	30221 J2	3FB
110	170	38	233	390	42,5	2 600	3 600	3,05	32022 X/Q	4DC
	170	47	281	500	53	2 600	3 600	3,85	33022	2DE
	180	56	369	630	67	2 600	3 400	5,55	33122	3EE
110	200	41	308	405	45	2 400	3 200	5,10	30222 J2	3FB
	200	56	402	570	61	2 400	3 200	7,10	32222 J2	3FC
	240	54,5	473	585	62	2 200	2 800	11,0	30322 J2	2GB
	240	63	457	585	62	1 900	2 800	12,0	31322 XJ2	7GB
	240	84,5	627	830	86,5	1 900	2 800	17,0	32322	2GD

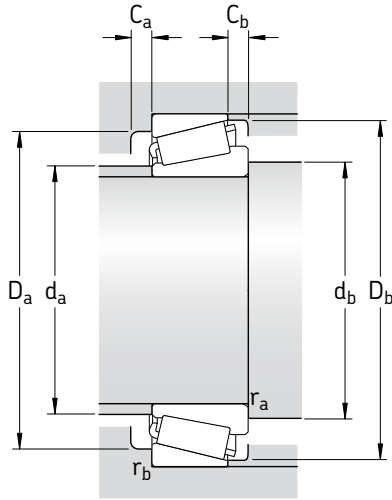

Dimensions			Abutment and fillet dimensions										Calculation factors						
d	d_1	B	C	$r_{1,2}$	$r_{3,4}$	a	d_a	d_b	D_a	D_a	D_b	C_a	C_b	r_a	r_b	e	Y	Y_0	
							mm										-		
100	119	25	20	1,5	1,5	24	109	107	131	132	135	5	5	1,5	1,5	0,33	1,8	1	
	121	22,5	17,5	3	3	30	109	112	133	131	140	4	6,5	2,5	2,5	0,48	1,25	0,7	
	125	32	24	2	1,5	32	110	108	134	142	144	6	8	2	1,5	0,46	1,3	0,7	
	122	39	32,5	2	1,5	29	109	108	135	142	143	7	6,5	2	1,5	0,3	2	1,1	
	128	42	34	8	3,5	32	111	124	140	145	151	7	8	7	3	0,33	1,8	1	
	130	40	32	3	2,5	38	110	112	139	148	154	7	9	2,5	2	0,48	1,27	0,7	
	130	46	39	3	3	35	111	112	145	151	157	7	8	2,5	2,5	0,31	1,9	1,1	
	133	34	29	3	2,5	35	116	112	157	168	168	5	8	2,5	2	0,43	1,4	0,8	
	135	46	39	3	2,5	41	115	112	154	168	171	5	10	2,5	2	0,43	1,4	0,8	
	139	63	48	3	2,5	43	112	112	151	168	172	10	15	2,5	2	0,4	1,5	0,8	
105	148	47	39	4	3	40	127	115	184	201	197	6	12,5	3	2,5	0,35	1,7	0,9	
	158	51	35	4	3	65	121	115	168	201	202	7	21,5	3	2,5	0,83	0,72	0,4	
	151	73	60	4	3	51	123	115	177	201	200	8	17,5	3	2,5	0,35	1,7	0,9	
	132	35	26	2,5	2	34	116	116	143	150	154	6	9	2	2	0,44	1,35	0,8	
	131	43	34	2,5	2	31	117	116	145	150	153	7	9	2	2	0,28	2,1	1,1	
	141	36	30	3	2,5	37	123	117	165	178	177	6	9	2,5	2	0,43	1,4	0,8	
110	143	50	43	3	2,5	44	120	117	161	178	180	6	10	2,5	2	0,43	1,4	0,8	
	158	77	63	4	3	53	129	120	185	211	209	9	18,5	3	2,5	0,35	1,7	0,9	
	129	25	20	1,5	1,5	26	118	117	140	142	145	5	5	1,5	1,5	0,35	1,7	0,9	
	140	38	29	2,5	2	36	123	121	152	160	163	7	9	2	2	0,43	1,4	0,8	
	139	47	37	2,5	2	34	123	121	152	160	161	7	10	2	2	0,28	2,1	1,1	
	146	56	43	2,5	2	44	121	121	155	170	174	9	13	2	2	0,43	1,4	0,8	
	148	38	32	3	2,5	39	129	122	174	188	187	6	9	2,5	2	0,43	1,4	0,8	
	151	53	46	3	2,5	46	127	122	170	188	190	6	10	2,5	2	0,43	1,4	0,8	
	165	50	42	4	3	43	142	125	206	226	220	8	12,5	3	2,5	0,35	1,7	0,9	
	176	57	38	4	3	72	135	125	188	226	224	7	25	3	2,5	0,83	0,72	0,4	
168	80	65	4	3	55	137	125	198	226	222	9	19,5	3	2,5	0,35	1,7	0,9		

Metric single row taper roller bearings
d 120 – 150 mm

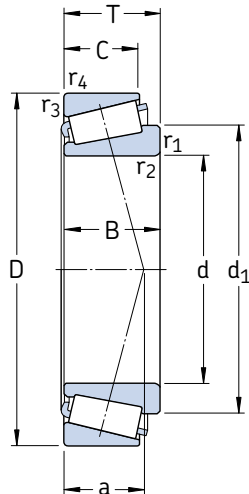

Principal dimensions			Basic load ratings		Fatigue load limit P_u	Speed ratings		Mass	Designation	Dimension Series to ISO 355
d	D	T	dynamic	static		Refer-ence speed	Limiting speed			
			C	C_0						
mm			kN		kN	r/min		kg	–	–
120	165	29	165	305	32	2 600	3 800	1,80	32924	2CC
	170	27	157	250	26,5	2 600	3 800	1,70	T4CB 120	4CB
	180	38	242	415	44	2 400	3 400	3,25	32024 X	4DC
	180	48	292	540	56	2 600	3 400	4,20	33024	2DE
	215	43,5	341	465	49	2 200	3 000	6,15	30224 J2	4FB
	215	61,5	468	695	72	2 200	3 000	9,15	32224 J2	4FD
	260	59,5	561	710	73,5	2 000	2 600	14,0	30324 J2	2GB
	260	68	539	695	73,5	1 700	2 400	15,5	31324 XJ2	7GB
	260	90,5	792	1 120	110	1 800	2 600	21,5	32324 J2	2GD
	130	180	32	198	365	38	2 400	3 600	2,40	32926
200		45	314	540	55	2 200	3 000	4,95	32026 X	4EC
230		43,75	369	490	53	2 000	2 800	7,60	30226 J2	4FB
230		67,75	550	830	85	2 000	2 800	11,5	32226 J2	4FD
280		63,75	627	800	83	1 800	2 400	17,0	30326 J2	2GB
280		72	605	780	81,5	1 600	2 400	18,5	31326 XJ2	7GB
140	190	32	205	390	40	2 200	3 400	2,55	32928	2CC
	195	29	194	325	33,5	2 200	3 200	2,40	T4CB 140	4CB
	210	45	330	585	58,5	2 200	2 800	5,25	32028 X	4DC
	250	45,75	418	570	58,5	1 900	2 600	8,65	30228 J2	4FB
	250	71,75	644	1 000	100	1 900	2 600	14,5	32228 J2	4FD
	300	77	693	900	88	1 500	2 200	24,5	31328 XJ2	7GB
150	210	32	233	390	40	2 000	3 000	3,05	T4DB 150	4DB
	225	48	369	655	65,5	2 000	2 600	6,35	32030 X	4EC
	225	59	457	865	86,5	2 000	2 600	8,15	33030	2EE
	270	49	429	560	57	1 800	2 400	11,0	30230	4GB
	270	77	737	1 140	112	1 700	2 400	17,5	32230 J2	4GD
	320	82	781	1 020	100	1 400	2 000	29,5	31330 XJ2	7GB

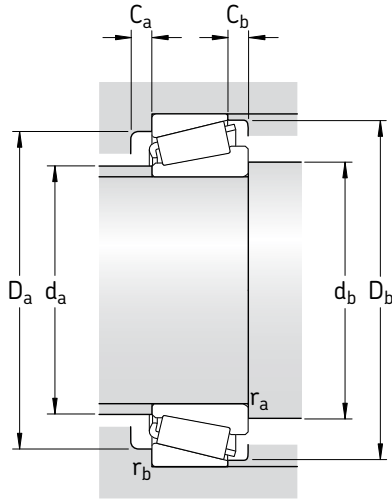

Dimensions							Abutment and fillet dimensions										Calculation factors		
d	d ₁	B	C	r _{1,2}	r _{3,4}	a	d _a	d _b	D _a	D _a	D _b	C _a	C _b	r _a	r _b	e	Y	Y ₀	
							mm										-		
120	141	29	23	1,5	1,5	29	130	127	154	157	160	5	6	1,5	1,5	0,35	1,7	0,9	
	142	25	19,5	3	3	34	130	132	157	157	164	4	7,5	2,5	2,5	0,48	1,25	0,7	
	150	38	29	2,5	2	39	132	131	161	170	173	7	9	2	2	0,46	1,3	0,7	
	149	48	38	2,5	2	36	132	131	160	170	171	6	10	2	2	0,3	2	1,1	
	161	40	34	3	2,5	43	141	132	187	203	201	6	9,5	2,5	2	0,43	1,4	0,8	
	163	58	50	3	2,5	51	137	132	181	203	204	7	11,5	2,5	2	0,43	1,4	0,8	
	178	55	46	4	3	47	153	135	221	245	237	7	13,5	3	2,5	0,35	1,7	0,9	
	190	62	42	4	3	78	145	135	203	245	244	9	26	3	2,5	0,83	0,72	0,4	
	181	86	69	4	3	60	148	135	213	245	239	9	21,5	3	2,5	0,35	1,7	0,9	
	130	153	32	25	2	1,5	31	141	140	167	172	173	6	7	2	1,5	0,33	1,8	1
		165	45	34	2,5	2	42	144	142	178	190	192	7	11	2	2	0,43	1,4	0,8
		173	40	34	4	3	45	152	146	203	216	217	7	9,5	3	2,5	0,43	1,4	0,8
176		64	54	4	3	56	146	146	193	216	219	7	13,5	3	2,5	0,43	1,4	0,8	
196		58	49	5	4	51	164	150	239	263	255	8	14,5	4	3	0,35	1,7	0,9	
204		66	44	5	4	84	157	150	218	263	261	8	28	4	3	0,83	0,72	0,4	
140		163	32	25	2	1,5	33	150	150	177	182	184	6	7	2	1,5	0,35	1,7	0,9
		165	27	21	3	3	40	151	154	180	181	189	5	8	2,5	2,5	0,5	1,2	0,7
		175	45	34	2,5	2	46	153	152	187	200	202	7	11	2	2	0,46	1,3	0,7
		186	42	36	4	3	47	164	156	219	236	234	7	9,5	3	2,5	0,43	1,4	0,8
		191	68	58	4	3	60	159	156	210	236	238	8	13,5	3	2,5	0,43	1,4	0,8
		219	70	47	5	4	90	169	160	235	283	280	9	30	4	3	0,83	0,72	0,4
	150	177	30	23	3	3	41	162	162	194	196	203	5	9	2,5	2,5	0,46	1,3	0,7
		187	48	36	3	2,5	49	164	164	200	213	216	8	12	2,5	2	0,46	1,3	0,7
		188	59	46	3	2,5	48	164	162	200	213	217	8	13	2,5	2	0,37	1,6	0,9
		200	45	38	4	3	50	175	166	234	256	250	9	11	3	2,5	0,43	1,4	0,8
		205	73	60	4	3	64	171	166	226	256	254	8	17	3	2,5	0,43	1,4	0,8
		234	75	50	5	4	96	181	170	251	303	300	9	32	4	3	0,83	0,72	0,4

Metric single row taper roller bearings
d 160 – 220 mm

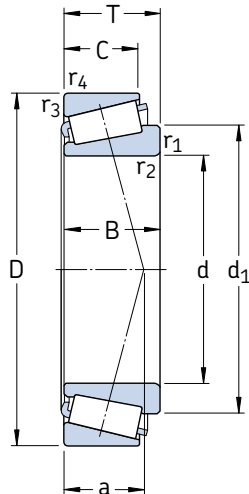

Principal dimensions			Basic load ratings		Fatigue load limit P_u	Speed ratings		Mass	Designation	Dimension Series to ISO 355 (ABMA)
d	D	T	dynamic	static		Reference speed	Limiting speed			
			C	C_0						
mm			kN		kN	r/min		kg	–	–
160	220	32	242	415	41,5	2 000	2 800	3,25	T4DB 160	4DB
	240	51	429	780	78	1 800	2 400	7,75	32032 X	4EC
	245	61	528	980	95	1 800	2 600	10,5	T4EE 160/VB406	4EE
	290	52	528	735	72	1 600	2 200	13,0	30232 J2	4GB
	290	84	880	1 400	132	1 600	2 200	25,5	32232 J2	4GD
	340	75	913	1 180	114	1 500	2 000	29,0	30332 J2	2GB
170	230	32	251	440	43	1 900	2 800	3,45	T4DB 170	4DB
	230	38	286	585	55	1 900	2 800	4,50	32934	3DC
	260	57	512	915	90	1 700	2 200	10,5	32034 X	4EC
	310	57	616	865	83	1 500	2 000	19,0	30234 J2	4GB
	310	91	1 010	1 630	150	1 500	2 000	28,5	32234 J2	4GD
	340	75	913	1 180	114	1 500	2 000	29,0	30332 J2	2GB
180	240	32	251	450	44	1 800	2 600	3,60	T4DB 180	4DB
	250	45	352	735	68	1 700	2 600	6,65	32936	4DC
	280	64	644	1 160	110	1 600	2 200	14,5	32036 X	3FD
	320	57	583	815	80	1 500	2 000	20,0	30236 J2	4GB
	320	91	1 010	1 630	150	1 400	1 900	29,5	32236 J2	4GD
	340	75	913	1 180	114	1 500	2 000	29,0	30332 J2	2GB
190	260	45	358	765	72	1 600	2 400	7,00	32938	4DC
	260	46	380	800	75	1 600	2 400	6,70	JM 738249/210	(M 738200)
	290	64	660	1 200	112	1 500	2 000	15,0	32038 X	4FD
	340	60	721	1 000	95	1 400	1 800	24,0	30238 J2	4GB
	340	60	721	1 000	95	1 400	1 800	24,0	30238 J2	4GB
200	270	37	330	600	57	1 600	2 400	5,45	T4DB 200	4DB
	280	51	473	950	88	1 500	2 200	9,50	32940	3EC
	310	70	748	1 370	127	1 400	1 900	19,5	32040 X	4FD
	360	64	792	1 120	106	1 300	1 700	25,0	30240 J2	4GB
	360	104	1 210	2 000	180	1 300	1 700	42,5	32240 J2	3GD
	360	104	1 210	2 000	180	1 300	1 700	42,5	32240 J2	3GD
220	285	41	396	830	75	1 500	2 200	6,45	T2DC 220	2DC
	300	51	484	1 000	91,5	1 400	2 000	10,0	32944	3EC
	340	76	897	1 660	150	1 300	1 700	25,5	32044 X	4FD
	400	72	990	1 400	129	1 200	1 600	40,0	30244 J2	–
	400	114	1 610	2 700	232	1 100	1 500	60,0	32244 J2	–
	400	114	1 610	2 700	232	1 100	1 500	60,0	32244 J2	–

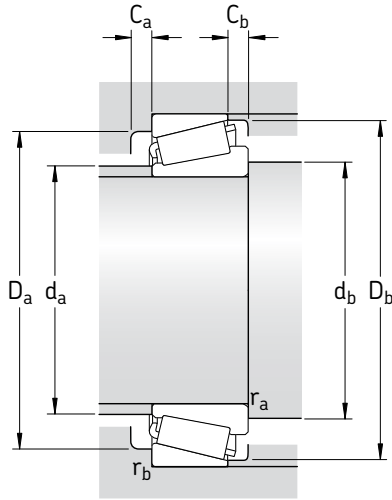

Dimensions							Abutment and fillet dimensions							Calculation factors				
d	d_1	B	C	$r_{1,2}$ min	$r_{3,4}$ min	a	d_a max	d_b min	D_a min	D_a max	D_b min	C_a min	C_b min	r_a max	r_b max	e	Y	Y_0
mm							mm							-				
160	187	30	23	3	3	44	172	174	204	206	213	5	9	2,5	2,5	0,48	1,25	0,7
	200	51	38	3	2,5	52	175	174	213	228	231	8	13	2,5	2	0,46	1,3	0,7
	203	59	50	3	2	57	174	174	229	233	236	9	11	2,5	2	0,44	1,35	0,8
	214	48	40	4	3	54	189	176	252	275	269	8	12	3	2,5	0,43	1,4	0,8
	221	80	67	4	3	70	183	176	242	275	274	10	17	3	2,5	0,43	1,4	0,8
	233	68	58	5	4	61	201	180	290	323	310	9	17	4	3	0,35	1,7	0,9
170	197	30	23	3	3	44	182	184	215	216	223	6	9	2,5	2,5	0,46	1,3	0,7
	200	38	30	2,5	2	42	183	182	213	220	222	7	8	2	2	0,37	1,6	0,9
	214	57	43	3	2,5	56	188	184	230	246	249	10	14	2,5	2	0,44	1,35	0,8
	230	52	43	5	4	58	203	190	268	293	288	8	14	4	3	0,43	1,4	0,8
	237	86	71	5	4	75	196	190	259	293	294	10	20	4	3	0,43	1,4	0,8
	180	207	30	23	3	3	48	191	194	224	226	233	6	9	2,5	2,5	0,48	1,25
216		45	34	2,5	2	53	194	192	225	240	241	8	11	2	2	0,48	1,25	0,7
229		64	48	3	2,5	59	199	194	247	266	267	10	16	2,5	2	0,43	1,4	0,8
	239	52	43	5	4	61	211	200	278	303	297	9	14	4	3	0,44	1,35	0,8
	247	86	71	5	4	78	204	200	267	303	303	10	20	4	3	0,44	1,35	0,8
	190	227	45	34	2,5	2	55	204	202	235	248	251	8	11	2	2	0,48	1,25
227		44	36,5	3	2,5	55	205	204	235	256	252	8	9,5	2,5	2	0,48	1,25	0,7
240		64	48	3	2,5	62	210	204	257	276	279	10	16	2,5	2	0,44	1,35	0,8
254		55	46	5	4	63	224	210	298	323	318	9	14	4	3	0,43	1,4	0,8
200	232	34	27	3	3	53	214	214	251	255	262	6	10	2,5	2,5	0,48	1,25	0,7
	239	51	39	3	2,5	53	217	214	257	266	271	9	12	2,5	2	0,4	1,5	0,8
	254	70	53	3	2,5	66	222	214	273	296	297	11	17	2,5	2	0,43	1,4	0,8
	268	58	48	5	4	68	237	220	315	343	336	9	16	4	3	0,43	1,4	0,8
	274	98	82	5	4	83	231	220	302	343	340	11	22	4	3	0,4	1,5	0,8
220	249	40	33	4	3	45	233	236	270	270	277	7	8	3	2,5	0,31	1,9	1,1
	259	51	39	3	2,5	58	234	234	275	286	290	9	12	2,5	2	0,43	1,4	0,8
	279	76	57	4	3	72	244	236	300	325	326	12	19	3	2,5	0,43	1,4	0,8
	294	65	54	5	4	74	259	242	348	383	371	10	18	4	3	0,43	1,4	0,8
	306	108	90	5	4	95	253	242	334	383	379	13	24	4	3	0,43	1,4	0,8

Metric single row taper roller bearings
d 240 – 360 mm

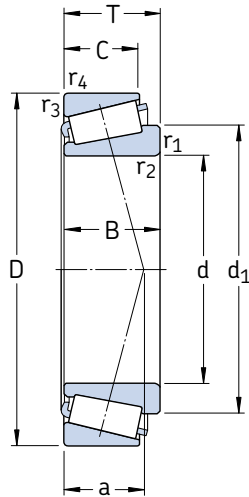

Principal dimensions			Basic load ratings		Fatigue load limit P_u	Speed ratings		Mass	Designation	Dimension Series to ISO 355
d	D	T	dynamic	static		Refer- ence speed	Limiting speed			
mm			kN		kN	r/min		kg	–	–
240	320	42	429	815	73,5	1 300	1 900	8,45	T4EB 240/VE174 32948 T2EE 240/VB406	4EB
	320	51	512	1 080	96,5	1 300	1 900	11,0		4EC
	320	57	616	1 320	120	1 300	1 900	12,5		2EE
	360	76	935	1 800	160	1 200	1 600	27,5	32048 X	4FD
	440	127	1 790	3 350	275	1 000	1 400	83,5	32248 J3	–
260	400	87	1 170	2 200	190	1 100	1 400	40,0	32052 X	4FC
	480	137	2 200	3 650	300	900	1 200	105	32252 J2/HA1	–
	540	113	2 120	3 050	250	850	1 200	110	30352 J2	–
280	380	63,5	765	1 660	143	1 100	1 600	20,0	32956/C02	4EC
	420	87	1 210	2 360	200	1 000	1 300	40,5	32056 X	4FC
300	420	76	1 050	2 240	190	950	1 400	32,0	32960	3FD
	460	100	1 540	3 000	250	900	1 200	58,0	32060 X	4GD
	540	149	2 750	4 750	365	800	1 100	140	32260 J2/HA1	–
320	440	76	1 080	2 360	196	900	1 300	33,5	32964	3FD
	480	100	1 540	3 100	255	850	1 100	64,0	32064 X	4GD
340	460	76	1 080	2 400	200	850	1 300	35,0	32968	4FD
360	480	76	1 120	2 550	204	800	1 200	37,0	32972	4FD

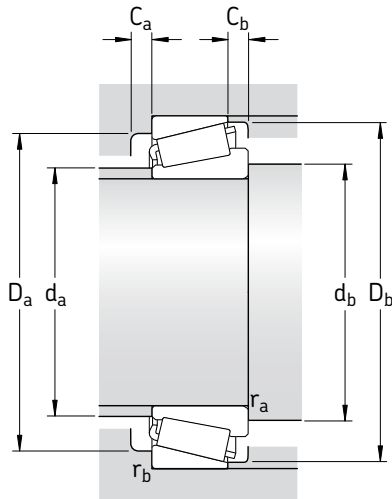

Dimensions							Abutment and fillet dimensions										Calculation factors		
d	d ₁ ~	B	C	r _{1,2} min	r _{3,4} min	a	d _a max	d _b min	D _a min	D _a max	D _b min	C _a min	C _b min	r _a max	r _b max	e	Y	Y ₀	
mm							mm										-		
240	276	39	30	3	3	60	256	254	299	305	310	7	12	2,5	2,5	0,46	1,3	0,7	
	279	51	39	3	2,5	64	255	254	294	306	311	9	12	2,5	2	0,46	1,3	0,7	
	277	56	46	3	2	58	254	254	296	308	311	9	11	2,5	2	0,35	1,7	0,9	
	299	76	57	4	3	78	262	256	318	345	346	12	19	3	2,5	0,46	1,3	0,7	
	346	120	100	5	4	105	290	262	365	420	415	13	27	4	3	0,43	1,4	0,8	
260	328	87	65	5	4	84	287	282	352	383	383	13	22	4	3	0,43	1,4	0,8	
	366	130	106	6	5	112	303	286	401	458	454	16	31	5	4	0,43	1,4	0,8	
	376	102	85	6	6	97	325	286	461	514	493	15	28	5	5	0,35	1,7	0,9	
280	329	63,5	48	3	2,5	74	298	295	348	366	368	11	15,5	2,5	2	0,43	1,4	0,8	
	348	87	65	5	4	89	305	302	370	400	402	14	22	4	3	0,46	1,3	0,7	
300	358	76	57	4	3	79	324	317	383	404	405	12	19	3	2,5	0,4	1,5	0,8	
	377	100	74	5	4	97	330	322	404	440	439	15	26	4	3	0,43	1,4	0,8	
	413	140	115	6	5	126	343	326	453	518	511	17	34	5	4	0,43	1,4	0,8	
320	379	76	57	4	3	84	343	337	402	424	426	13	19	3	2,5	0,43	1,4	0,8	
	399	100	74	5	4	103	350	342	424	460	461	15	26	4	3	0,46	1,3	0,7	
340	399	76	57	4	3	90	361	357	421	444	446	14	19	3	2,5	0,44	1,35	0,8	
360	419	76	57	4	3	96	380	377	439	464	466	14	19	3	2,5	0,46	1,3	0,7	

Inch single row taper roller bearings

d **14,989 – 22,225** mm

0,5906 – 0,8750 in

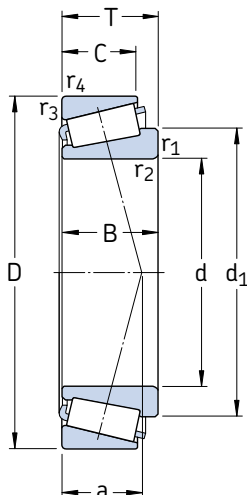

Principal dimensions			Basic load ratings		Fatigue load limit P_u	Speed ratings		Mass	Designation	Series
d	D	T	dynamic C	static C_0		Refer- ence speed	Limiting speed			
mm/in			kN		kN	r/min		kg	–	–
14,989 0,5906	34,988 1,3775	10,998 0,4326	13,4	13,2	1,29	16 000	24 000	0,051	A 4059/A 4138	A 4000
15,875 0,6250	41,275	14,288	22	21,2	2,16	14 000	20 000	0,090	03062/03162/Q	03000
	42,862	14,288	17,6	17,6	1,83	12 000	17 000	0,10	11590/11520/Q	11500
	1,6875	0,5625								
17,462 0,6875	39,878	13,843	21,2	20,8	2,12	13 000	20 000	0,081	LM 11749/710/Q	LM 11700
	1,5700	0,5450								
	39,878	13,843	21,2	20,8	2,12	13 000	20 000	0,081	LM 11749/710/QVC027	LM 11700
19,050 0,7500	45,237	15,494	27,5	27,5	2,9	12 000	18 000	0,12	LM 11949/910/Q	LM 11900
	1,7810	0,6100								
	49,225	18,034	39,1	40	4,3	11 000	17 000	0,17	09067/09195/Q	09000
	1,9380	0,7100								
21,430 0,8437	49,225	19,845	39,1	40	4,3	11 000	17 000	0,18	09074/09195/QVQ494	09000
	1,9380	0,7813								
	45,237	15,494	27,5	31	3,2	11 000	17 000	0,12	LM 12748/710	LM 12700
21,986 0,8656	1,7810	0,6100								
	50,005	17,526	36,9	38	4,15	11 000	16 000	0,17	M 12649/610/Q	M 12600
	1,9687	0,6900								
21,986 0,8656	45,237	15,494	27,5	31	3,2	11 000	17 000	0,12	LM 12749/710/Q	LM 12700
	1,7810	0,6100								
	45,974	15,494	27,5	31	3,2	11 000	17 000	0,12	LM 12749/711/Q	LM 12700
22,225 0,8750	1,8100	0,6100								
	52,388	19,368	41,8	44	4,8	10 000	15 000	0,20	1380/1328/Q	1300
	2,0625	0,7625								

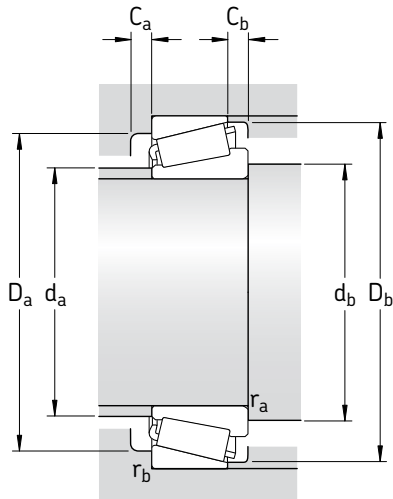

Dimensions							Abutment and fillet dimensions								Calculation factors			
d	d ₁ ~	B	C	r _{1,2} min	r _{3,4} min	a	d _a max	d _b min	D _a min	D _a max	D _b min	C _a min	C _b min	r _a max	r _b max	e	Y	Y ₀
mm/in							mm								-			
14,989 0,5906	25,3	10,988 0,4326	8,7300 0,3437	0,8 0,03	1,3 0,05	8	20	20	28	29	31	2	2	0,8	1,3	0,46	1,3	0,7
15,875 0,6250	28,1	14,681 0,5780	11,112 0,4375	1,3 0,05	2 0,08	9	22	22	33,5	33,5	37	2	3	1,3	2	0,31	1,9	1,1
	31,1	14,288 0,5625	9,5250 0,3750	1,5 0,06	1,5 0,06	13	23	23	32	36	38	2	4,5	1,5	1,5	0,72	0,84	0,45
17,462 0,6875	28,9	14,605 0,5750	10,668 0,4200	1,3 0,05	1,3 0,05	9	23	23,5	33,5	33,5	36	2	3	1,3	1,3	0,28	2,1	1,1
	28,9	14,605 0,5750	10,668 0,4200	1,3 0,05	1,3 0,05	9	23	23,5	33,5	33,5	36	2	3	1,3	1,3	0,28	2,1	1,1
19,050 0,7500	31,4	16,637 0,6550	12,065 0,4750	1,3 0,05	1,3 0,05	10	25	25	38	38,5	41	3	3	1,3	1,3	0,3	2	1,1
	32,3	19,050 0,7500	14,288 0,5625	1,3 0,05	1,3 0,05	10	26	25	41	42,5	44	4	3,5	1,3	1,3	0,27	2,2	1,3
	32,3	21,539 0,8480	14,288 0,5625	1,5 0,06	1,3 0,05	10	26	26	41	42,5	44	5	5,5	1,5	1,3	0,27	2,2	1,3
21,430 0,8437	34,3	16,637 0,6550	12,065 0,4750	1,3 0,05	1,3 0,05	10	28	27,5	39	40	42	3	3	1,3	1,3	0,31	1,9	1,1
	34,3	18,288 0,7200	13,970 0,5500	1,3 0,05	1,3 0,05	11	28	27,5	43	43,5	46	3	3,5	1,3	1,3	0,28	2,1	1,1
21,986 0,8656	34,3	16,637 0,6550	12,065 0,4750	1,3 0,05	1,3 0,05	10	28	28	39	40	42	3	3	1,3	1,3	0,31	1,9	1,1
	34,3	16,637 0,6550	12,065 0,4750	1,3 0,05	1,3 0,05	10	28	28	39	40	42	3	3	1,3	1,3	0,31	1,9	1,1
22,225 0,8750	36	20,168 0,7940	14,288 0,5625	1,5 0,06	1,5 0,06	11	29	29,5	45	45	48	4	5	1,5	1,5	0,30	2	1,1

Inch single row taper roller bearings

d **25,400 – 30,162** mm

1,000 – 1,1875 in

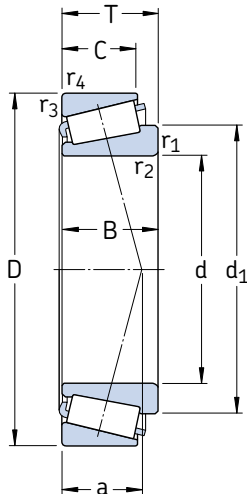

Principal dimensions			Basic load ratings		Fatigue load limit P_u	Speed ratings		Mass	Designation	Series
d	D	T	dynamic C	static C_0		Refer- ence speed	Limiting speed			
mm/in			kN		kN	r/min		kg	–	–
25,400 1,0000	50,292	14,224	26	30	3	10 000	15 000	0,13	L 44643/610/Q	L 44600
	1,9800	0,5600	28,1	30,5	3,15	10 000	15 000	0,13	07100 S/07210 X/Q	07000
	50,800	15,011								
	2,0000	0,5910	40,2	45,5	4,9	9 000	13 000	0,23	15578/15520	15500
	57,150	17,462								
	2,2500	0,6875	39,6	45	5	9 000	13 000	0,23	M 84548/2/510/2/QVQ506	M 84500
	57,150	19,431								
	2,2500	0,7650	48,4	57	6,2	8 000	12 000	0,31	15101/15245	15000
62,000	19,050									
2,4409	0,7500									
26,157 1,0298	61,912	19,050	48,4	57	6,2	8 000	12 000	0,29	15103 S/15243/Q	15000
	2,4375	0,7500	48,4	57	6,2	8 000	12 000	0,29	15103 S/15245/Q	15000
	62,000	19,050								
2,4409	0,7500									
26,988 1,0625	50,292	14,224	26	30	3	10 000	15 000	0,11	L 44649/610/Q	L 44600
	1,9800	0,5600								
27,500 1,0826	57,150	19,845	45,7	51	5,6	9 000	13 000	0,22	1982 F/1924 A/QVQ519	1900
	2,2500	0,7813								
28,575 1,1250	57,150	19,845	45,7	51	5,6	9 000	13 000	0,22	1985/1922/Q	1900
	2,2500	0,7813	45,7	51	5,6	9 000	13 000	0,22	1988/1922/Q	1900
	57,150	19,845								
	2,2500	0,7813	49,5	61	6,8	8 000	11 000	0,35	M 86647/610/QCL7C	M 86600
	64,292	21,433								
2,5312	0,8438	99	140	15	7 000	10 000	1,05	02872/02820/Q	02800	
73,025	22,225									
2,8750	0,8750									
29,000 1,1417	50,292	14,224	26	32,5	3,35	10 000	14 000	0,11	L 45449/410/Q	L 45400
	1,9800	0,5600								
30,162 1,1875	64,292	21,433	49,5	61	6,8	8 000	11 000	0,33	M 86649/2/610/2/QVQ506	M 86600
	2,5312	9,8435	55	69,5	7,8	7 500	11 000	0,41	M 88043/010/2/QCL7C	M 88000
	68,262	22,225								
	2,6875	0,8750								

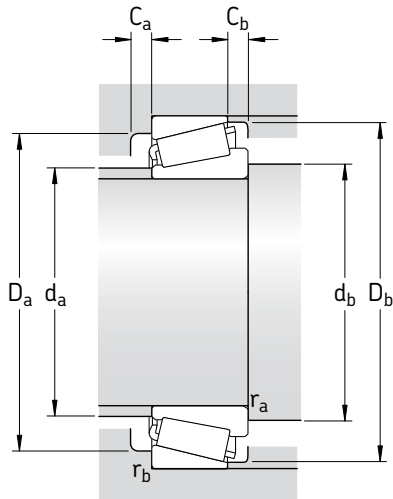

Dimensions							Abutment and fillet dimensions									Calculation factors		
d	d ₁ ~	B	C	r _{1,2} min	r _{3,4} min	a	d _a max	d _b min	D _a min	D _a max	D _b min	C _a min	C _b min	r _a max	r _b max	e	Y	Y ₀
mm/in							mm									-		
25,400 1,0000	39,1	14,732	10,668	1,3	1,3	11	33	31,5	43,5	43,5	47	2	3,5	1,3	1,3	0,37	1,6	0,9
		0,5800	0,4200	0,05	0,05													
	37,3	14,260	12,700	1,5	1,5	12	31	32,5	41	43,5	48	2	2	1,5	1,5	0,4	1,5	0,8
		0,5614	0,5000	0,06	0,06													
	42,3	17,462	13,495	1,3	1,5	12	35	31,5	49	50	53	3	3,5	1,3	1,5	0,35	1,7	0,9
42,5	19,431	14,732	1,5	1,5	16	33	32,5	45	50	53	3	4,5	1,5	1,5	0,54	1,1	0,6	
	0,7650	0,5800	0,06	0,06														
	45,8	20,638	14,288	0,8	1,3	13	38	30,5	54	55	58	4	4,5	0,8	1,3	0,35	1,7	0,9
	0,8125	0,5625	0,03	0,05														
26,157 1,0298	45,8	20,638	14,288	0,8	2	13	38	31	54	55	54	4	4,5	0,8	2	0,35	1,7	0,9
		0,8125	0,5625	0,03	0,08													
	45,8	20,638	14,288	0,8	1,3	13	38	31	54	55	58	4	4,5	0,8	1,3	0,35	1,7	0,9
		0,8125	0,5625	0,03	0,05													
26,988 1,0625	38,2	14,732	10,668	3,5	1,3	11	33	38	43,5	44	47	2	3,5	3	1,3	0,37	1,6	0,9
		0,5800	0,4200	0,14	0,05													
27,500 1,0826	42	20,165	15,875	2,5	0,8	14	35	36,5	49	52	54	3	3,5	2,5	0,8	0,33	1,8	1
		0,7939	0,6250	0,1	0,03													
28,575 1,1250	42	19,355	15,875	0,8	1,5	14	35	33,5	49	49,5	54	3	3,5	0,8	1,5	0,33	1,8	1
		0,7620	0,6250	0,03	0,06													
	42	19,355	15,875	3,5	1,5	14	35	40	49	49,5	54	3	3,5	3	1,5	0,33	1,8	1
		0,7620	0,6250	0,14	0,06													
	48,8	21,433	16,670	1,5	1,5	18	38	36	51	56,5	60	3	4,5	1,5	1,5	0,54	1,1	0,6
54,2	0,8438	0,6563	0,06	0,06														
	22,225	17,462	0,8	3,3	26	44	33,5	60	61,5	67	3	4,5	0,8	3	0,46	1,3	0,7	
	0,8750	0,6875	0,03	0,13														
29,000 1,1417	40,8	14,732	10,668	3,5	1,3	11	34	40	44	44	48	3	3,5	3	1,3	0,37	1,6	0,9
		0,5800	0,4200	0,14	0,05													
30,162 1,1875	48,8	21,433	16,670	1,5	1,5	18	37,5	3,5	51	56,5	60	3	4,5	1,5	1,5	0,54	1,1	0,6
		0,8438	0,6563	0,06	0,06													
	52,3	22,225	17,462	2,3	1,5	19	41	39	54	60,5	64	3	4,5	2	1,5	0,54	1,1	0,6
	0,8750	0,6875	0,09	0,06														

Inch single row taper roller bearings

d **31,750 – 34,988** mm

1,2500 – 1,3775 in

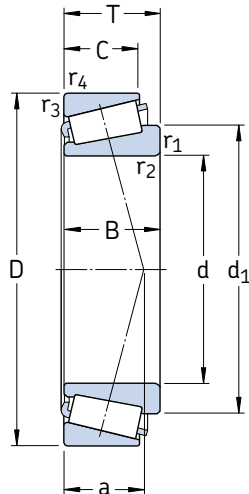

Principal dimensions			Basic load ratings		Fatigue load limit P_u	Speed ratings		Mass	Designation	Series
d	D	T	dynamic C	static C_0		Refer- ence speed	Limiting speed			
mm/in			kN		kN	r/min		kg	–	–
31,750 1,2500	59,131	15,875	34,7	41,5	4,4	8 500	12 000	0,18	LM 67048/010/Q	LM 67000
	2,3280	0,6250								
	61,912	19,050	48,4	57	6,2	8 000	12 000	0,24	15123/15243/Q	15000
	2,4375	0,7500								
	62,000	19,050	48,4	57	6,2	8 000	12 000	0,24	15123/15245/Q	15000
	2,4409	0,7500								
	73,025	29,370	70,4	95	10,4	6 700	10 000	0,62	HM 88542/510/Q	HM 88500
	2,8750	1,1563								
73,025	29,370	70,4	95	10,4	6 700	10 000	0,62	HM 88542/2/510/2/QCL7C	HM 88500	
2,8750	1,1563									
33,338 1,3125	68,262	22,225	55	69,5	7,8	7 500	11 000	0,38	M 88048/2/010/2/QCL7C	M 88000
	2,6875	0,8750								
	69,012	19,845	53,9	67	7,35	7 500	11 000	0,35	14131/14276/Q	14000
	2,7170	0,7813								
34,925 1,3750	65,088	18,034	47,3	57	6,2	7 500	11 000	0,25	LM 48548/510/Q	LM 48500
	2,5625	0,7100								
	65,088	18,034	47,3	57	6,2	7 500	11 000	0,25	LM 48548 A/510/Q	LM 48500
	2,5625	0,7100								
	69,012	19,845	53,9	67	7,35	7 500	11 000	0,34	14137 A/14276/Q	14000
	2,7170	0,7813								
	72,233	25,400	67,1	90	10	6 700	10 000	0,50	HM 88649/2/610/2/QCL7C	HM 88600
	2,8438	1,0000								
	73,025	23,812	72,1	88	9,8	7 000	10 000	0,47	25877/2/25821/2/Q	25800
	2,8750	0,9375								
	73,025	26,988	76,5	93	10,4	7 000	10 000	0,52	23690/23620/QCL7C	23600
	2,8750	1,0625								
76,200	29,370	85,8	106	12	6 700	10 000	0,63	31594/31520/Q	31500	
3,0000	1,1563									
76,200	29,370	78,1	106	11,8	6 300	9 500	0,66	HM 89446/2/410/2/QCL7C	HM 89400	
3,0000	1,1563									
34,988 1,3775	59,131	15,875	33	44	4,5	8 000	12 000	0,17	L 68149/110/Q	L 68100
	2,3280	0,6250								
	59,974	15,875	33	44	4,5	8 000	12 000	0,17	L 68149/111/Q	L 68100
	2,3612	0,6250								

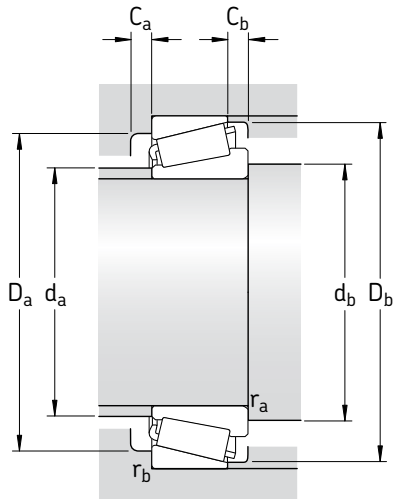

Dimensions							Abutment and fillet dimensions									Calculation factors				
d	d_1 ~	B	C	$r_{1,2}$ min	$r_{3,4}$ min	a	d_a max	d_b min	D_a min	D_a max	D_b min	C_a min	C_b min	r_a max	r_b max	e	Y	Y_0		
mm/in							mm									-				
31,750 1,2500	44,9	16,764	11,811	3,6	1,3	13	38	42	51	53	55	3	4	3	1,3	0,4	1,5	0,8		
		0,6600	0,4650	0,14	0,05															
	45,8	19,050	14,288	4	2	13	38	44	54	55	58	4	3,5	3	2	0,35	1,7	0,9		
		0,7500	0,5625	0,16	0,08															
	45,8	19,050	14,288	4	1,3	13	38	44	54	55	58	4	3,5	3	1,3	0,35	1,7	0,9		
33,338 1,3125	56,9	27,783	23,020	1,3	3,3	23	42	38	55	62	69	3	6	1,3	3	0,54	1,1	0,6		
		1,0938	0,9063	0,05	0,13															
	56,9	27,783	23,020	1,3	3,3	23	42	38	55	62	69	3	6	1,3	3	0,54	1,1	0,6		
		1,0938	0,9063	0,05	0,13															
	52,3	22,225	17,462	0,8	1,5	19	41	38,5	54	60,5	64	3	4,5	0,8	1,5	0,54	1,1	0,6		
34,925 1,3750	50,7	19,583	15,875	0,8	1,3	15	43	38,5	47	61,5	63	3	3,5	0,8	1,3	0,37	1,6	0,9		
		0,7710	0,6250	0,03	0,05															
	50	18,288	13,970	3,5	1,3	14	42	46	57	58,5	61	3	4	3	1,3	0,37	1,6	0,9		
		0,7200	0,5500	0,14	0,05															
	50	18,288	13,970	0,8	1,3	14	42	40	57	58,5	61	3	4	0,8	1,3	0,37	1,6	0,9		
34,988 1,3775	50,7	19,583	15,875	1,5	1,3	15	43	42	47	61,5	63	3	3,5	1,5	1,3	0,37	1,6	0,9		
		0,7710	0,6250	0,06	0,05															
	55,9	25,400	19,842	2,3	2,3	20	42	44	57	63	68	5	5,5	2	2	0,54	1,1	0,6		
		1,0000	0,7812	0,09	0,09															
	52,5	24,608	19,050	1,5	0,8	15	44	42	62	66,5	67	5	4,5	1,5	0,8	0,3	2	1,1		
		0,9688	0,7500	0,06	0,03															
	52,3	26,975	22,225	3,5	1,5	19	42	46	59	65	67	3	4,5	3	1,5	0,37	1,6	0,9		
		1,0625	0,8750	0,14	0,6															
	55,6	28,575	23,812	1,5	3,3	20	44	42	62	64,5	71	4	5,5	1,5	3	0,4	1,5	0,8		
		1,1250	0,9375	0,06	0,13															
59,3	28,575	23,020	3,5	3,3	23	44	46	58	65	72	3	6	3	3	0,54	1,1	0,6			
	1,1250	0,9063	0,14	0,13																
34,988 1,3775	48,4	16,764	11,938	3,5	1,3	13	41	46	52	53,5	56	3	3,5	3	1,3	0,43	1,4	0,8		
		0,6600	0,4700	0,14	0,05															
	48,4	16,764	11,938	3,5	1,3	13	41	46	52	53,5	56	3	3,5	3	1,3	0,43	1,4	0,8		
	0,6600	0,4700	0,14	0,05																

Inch single row taper roller bearings

d **36,487 – 40,988** mm

1,4365 – 1,6137 in

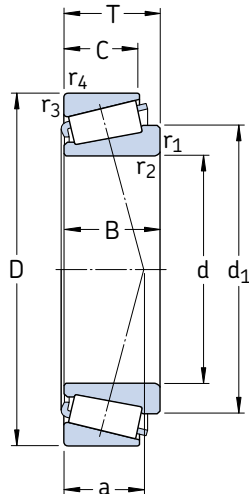

Principal dimensions			Basic load ratings		Fatigue load limit P_u	Speed ratings		Mass	Designation	Series	
d	D	T	dynamic C	static C_0		Refer- ence speed	Limiting speed				
mm/in			kN	kN	r/min	kg	–	–			
36,487 1,4365	73,025 2,8750	23,812 0,9375	72,1	88	9,8	7 000	10 000	0,45	25880/25820/Q	25800	
36,512 1,4375	76,200 3,0000	29,370 1,1563	78,1	106	11,8	6 300	9 500	0,64	HM 89449/2/410/2/QCL7C	HM 89400	
38,100 1,5000	65,088 2,5625	18,034 0,7100	42,9	57	6,1	7 500	11 000	0,25	LM 29748/710/Q	LM 29700	
	65,088 2,5625	18,034 0,7100	50	57	6,1	8 000	11 000	0,25	* LM 29749/710/Q	LM 29700	
	65,088 2,5625	19,812 0,7800	42,9	57	6,1	7 500	11 000	0,25	LM 29749/711/Q	LM 29700	
	65,088 2,5625	19,812 0,7800	42,9	57	6,1	7 500	11 000	0,25	LM 29749/711/QCL7CVA607	LM 29700	
	72,238 2,8440	20,638 0,8125	49,5	60	6,55	7 000	10 000	0,39	16150/16284/Q	16000	
	72,238 2,8440	23,812 0,9375	49,5	60	6,55	7 000	10 000	0,39	16150/16283/Q	16000	
	76,200 3,0000	23,812 0,9375	74,8	93	10,4	6 700	10 000	0,50	2788/2720/QCL7C	2700	
	79,375 3,1250	29,370 1,1563	91,3	110	12,5	6 700	9 500	0,67	3490/3420/QCL7CVQ492	3400	
	82,550 3,2500	29,370 1,1563	85,8	118	13,4	6 000	8 500	0,78	HM 801346/310/Q	HM 801300	
	82,550 3,2500	29,370 1,1563	85,8	118	13,4	6 000	8 500	0,77	HM 801346 X/2/310/QVQ523	HM 801300	
	88,500 3,4843	26,988 1,0625	101	114	13,2	6 300	9 000	0,83	418/414/Q	415	
	39,688 1,5625	73,025 2,8750	25,654 1,0100	66	86,5	9,3	6 700	10 000	0,45	M 201047/011/Q	M 201000
	40,988 1,6137	67,975 2,6762	17,500 0,6890	44	58,5	6,3	7 000	10 000	0,24	LM 300849/811/Q	LM 300800

* SKF Explorer bearing

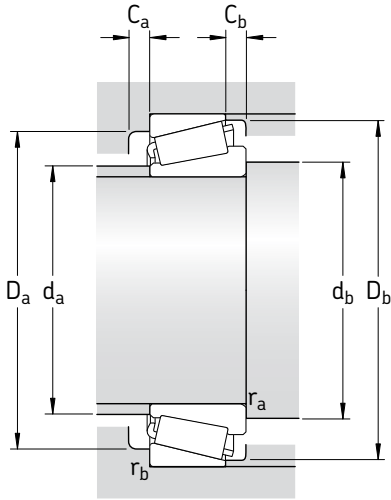

Dimensions							Abutment and fillet dimensions									Calculation factors		
d	d_1 ~	B	C	$r_{1,2}$ min	$r_{3,4}$ min	a	d_a max	d_b min	D_a min	D_a max	D_b min	C_a min	C_b min	r_a max	r_b max	e	Y	Y_0
mm/in							mm									-		
36,487 1,4365	52,5	24,608 0,9688	19,050 0,7500	1,5 0,06	2,3 0,09	15	44	43,5	62	66,5	67	5	4,5	1,5	2	0,3	2	1,1
36,512 1,4375	59,3	28,575 1,1250	23,020 0,9063	3,5 0,14	3,3 0,13	23	44	47,5	58	65	72	3	6	3	3	0,54	1,1	0,6
38,100 1,5000	51,8	18,288 0,7200	13,970 0,5500	2,3 0,09	1,3 0,05	15	44	47	58	58	61	2	4	2	1,3	0,33	1,8	1
	51,8	18,288 0,7200	13,970 0,5500	2,3 0,09	1,3 0,05	15	44	47	58	58	61	2	4	2	1,3	0,33	1,8	1
	51,8	18,288 0,7200	15,748 0,6200	2,3 0,09	1,3 0,05	15	44	47	57	58,5	61	2	4	2	1,3	0,33	1,8	1
	51,8	18,288 0,7200	15,748 0,6200	2,3 0,09	1,3 0,05	15	44	47	57	58,5	61	2	4	2	1,3	0,33	1,8	1
	53,8	20,638 0,8125	15,875 0,5625	3,5 0,14	1,3 0,05	19	45	49,5	58	65	66	3	4,5	3	1,3	0,4	1,5	0,8
	53,8	20,638 0,8125	19,050 0,7500	3,5 0,14	2,3 0,09	19	45	49,5	58	63	66	3	4,5	3	2	0,4	1,5	0,8
	54,8	25,654 1,0100	19,050 0,7500	3,5 0,14	3,3 0,13	16	46	49,5	64	65	69	5	4,5	3	3	0,3	2	1,1
	57,3	29,771 1,1721	23,812 0,9375	3,5 0,14	3,3 0,13	20	46	49,5	65	68	73	4	5,5	3	3	0,37	1,6	0,9
	64,1	28,575 1,1250	23,020 0,9063	0,8 0,03	3,3 0,13	24	49	43	64	71	78	4	6	0,8	3	0,54	1,1	0,6
	64,1	28,575 1,1250	23,020 0,9063	2,3 0,09	3,3 0,13	24	49	47	64	71	78	4	6	2	3	0,54	1,1	0,6
58,8	29,083 1,1450	22,225 0,8750	3,5 0,14	1,5 0,06	17	49	49,5	73	80,5	78	5	4,5	3	1,5	0,26	2,3	1,3	
39,688 1,5625	55,7	22,098 0,8700	21,336 0,8400	0,8 0,03	2,3 0,09	19	47	45	62	63,5	69	4	4,5	0,8	2	0,33	1,8	1
40,988 1,6137	54,3	18,000 0,7087	13,500 0,5313	3,6 0,14	1,5 0,06	14	48	48,5	60	60	64	3	4	3,5	1,5	0,35	1,7	0,9

Inch single row taper roller bearings

d **41,275 – 42,875** mm

1,6250 – 1,6880 in

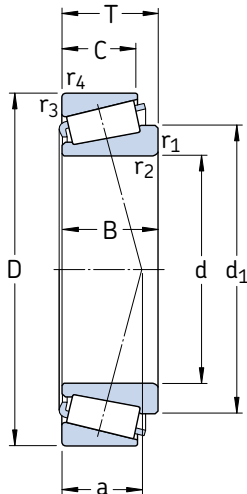

Principal dimensions			Basic load ratings		Fatigue load limit P_u	Speed ratings		Mass kg	Designation	Series
d	D	T	dynamic C	static C_0		Refer- ence speed	Limiting speed			
mm/in			kN		kN	r/min		kg	–	–
41,275 1,6250	73,025	16,667	46,8	56	6,2	6 700	10 000	0,27	18590/18520/Q	18500
	2,8750	0,6562								
	73,431	19,558	55	68	7,65	6 700	10 000	0,33	LM 501349/310/Q	LM 501300
	2,8910	0,7700								
	73,431	19,558	55	68	7,65	6 700	10 000	0,33	LM 501349/2/310/2/QCL7C	LM 501300
	2,8910	0,7700								
	73,431	21,430	55	68	7,65	6 700	10 000	0,35	LM 501349/314/Q	LM 501300
	2,8910	0,8437								
	76,200	18,009	45,7	56	6,1	6 700	9 500	0,34	11162/11300/Q	11000
	3,0000	0,7090								
	76,200	18,009	45,7	56	6,1	6 700	9 500	0,34	11163/11300/Q	11000
	3,0000	0,7090								
	76,200	22,225	68,2	86,5	9,65	6 700	9 500	0,43	24780/24720/Q	24700
	3,0000	0,8750								
	82,550	26,543	73,7	91,5	10,6	6 000	9 000	0,62	M 802048/011/QCL7C	M 802000
	3,2500	1,0450								
87,312	30,162	102	132	15	6 000	8 500	0,85	3585/3525/Q	3500	
3,4375	1,1875									
88,900	30,162	95,2	127	14,6	5 600	8 000	0,90	HM 803146/110/Q	HM 803100	
3,5000	1,1875									
88,900	30,162	95,2	127	14,6	5 600	8 000	0,90	HM 803146/2/110/2/QCL7C	HM 803100	
3,5000	1,1875									
101,600	34,925	151	190	22,8	5 000	7 500	1,45	526/522/Q	525	
4,0000	1,3750									
42,875 1,6880	82,931	23,812	80,9	106	12	6 000	9 000	0,57	25577/2/25520/2/Q	25500
	3,2650	0,9375								
	83,058	23,876	80,9	106	12	6 000	9 000	0,57	25577/2/25523/2/Q	25500
	3,2700	0,9400								

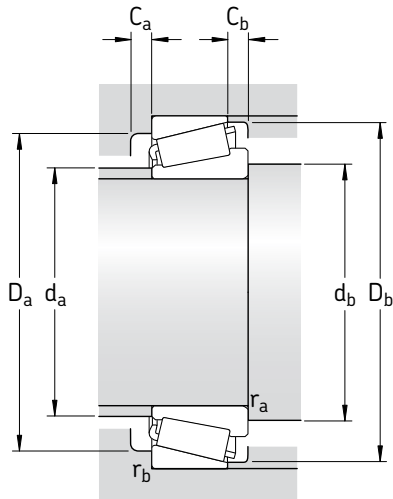

Dimensions							Abutment and fillet dimensions									Calculation factors		
d	d_1 ~	B	C	$r_{1,2}$ min	$r_{3,4}$ min	a	d_a max	d_b min	D_a min	D_a max	D_b min	C_a min	C_b min	r_a max	r_b max	e	Y	Y_0
mm/in							mm									-		
41,275 1,6250	56,1	17,462	12,700	3,5	1,5	14	49	52,5	65	65	68	3	3,5	3	1,5	0,35	1,7	0,9
		0,6875	0,5000	0,14	0,06													
	56,6	19,812	14,732	3,5	0,8	16	48	52,5	64	68	69	4	4,5	3	0,8	0,4	1,5	0,8
		0,7800	0,5800	0,14	0,03													
	56,6	19,812	14,732	3,5	0,8	16	48	52,5	64	68	69	4	4,5	3	0,8	0,4	1,5	0,8
		0,7800	0,5800	0,14	0,03													
	56,6	19,812	16,604	3,5	0,8	18	48	52,5	63	68	69	3	4,5	3	0,8	0,4	1,5	0,8
		0,7800	0,6537	0,14	0,03													
	58,1	17,384	14,288	1,5	1,5	17	50	49	65	68	71	3	4,5	1,5	1,5	0,48	1,25	0,7
		0,6844	0,5625	0,06	0,06													
	58,1	17,384	14,288	0,8	1,5	17	50	46	65	68	71	3	4,5	0,8	1,5	0,48	1,25	0,7
		0,6844	0,5625	0,03	0,06													
	57,7	23,020	17,462	3,5	0,8	17	48	52,5	64	64	71	3	3,5	3	0,8	0,4	1,5	0,8
		0,9063	0,6875	0,14	0,03													
	62,5	25,654	20,193	3,5	3,3	22	50	52,5	66	71	78	4	6	3	3	0,54	1,1	0,6
		1,0100	0,7950	0,14	0,13													
	63,1	30,886	23,812	1,5	3,3	20	53	49	73	76	80	4	6	1,5	3	0,31	1,9	1,1
		1,2160	0,9375	0,06	0,13													
	68,9	29,370	23,020	3,5	3,3	26	53	52,5	70	78	84	4	7	3	3	0,54	1,1	0,6
		1,1563	0,9063	0,14	0,13													
	68,9	29,370	23,020	3,5	3,3	26	53	52,5	70	78	84	4	7	3	3	0,54	1,1	0,6
		1,1563	0,9063	0,14	0,13													
	72,9	36,068	26,988	3,5	3,3	22	61	52,5	87	90,5	94	6	7,5	3	3	0,28	2,1	1,1
		1,4200	1,0625	0,14	0,13													
42,875 1,6880	62,1	25,400	19,050	3,5	0,8	17	53	54	71	77	76	5	4,5	3	0,8	0,33	1,8	1
		1,0000	0,7500	0,14	0,03													
	62,1	25,400	22,225	3,5	2,3	20	53	54	70	74	76	3	4,5	3	2	0,33	1,8	1
		1,0000	0,8750	0,14	0,09													

Inch single row taper roller bearings

d **44,450 – 45,618** mm

1,7500 – 1,7960 in

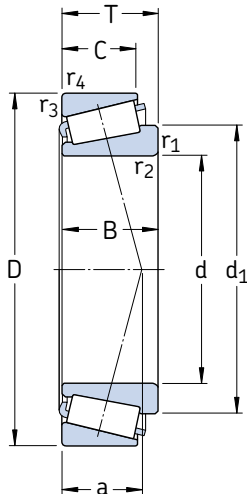

Principal dimensions			Basic load ratings		Fatigue load limit P_u	Speed ratings		Mass	Designation	Series		
d	D	T	dynamic C	static C_0		Refer- ence speed	Limiting speed					
mm/in			kN	kN	r/min	kg	–	–				
44,450 1,7500	82,931	23,812	80,9	106	11,8	6 000	9 000	0,57	25580/25520/Q	25500		
	3,2650	0,9375	80,9	106	11,8	6 000	9 000	0,57	25580/25523/Q	25500		
	82,931	26,988										
	3,2650	1,0625	80,9	106	11,8	6 000	9 000	0,57	25580/25522/Q	25500		
	83,058	23,876										
	3,2700	0,9400	88,900	30,162	95,2	127	14,6	5 600	8 000	1,50	HM 803149/110/Q	HM 803100
	3,5000	1,1875										
	88,900	30,162	95,2	127	14,6	5 600	8 000	1,50	HM 803149/2/110/2/QCL7C	HM 803100		
	3,5000	1,1875										
		95,250	30,958	101	122	14	4 800	7 000	1,00	HM 903249/2/210/2/Q	HM 903200	
		3,7500	1,2188									
		95,250	30,958	101	122	14	4 800	7 000	1,00	HM 903249/W/210/QCL7C	HM 903200	
		3,7500	1,2188									
		95,250	30,958	88	96,5	11,4	5 000	7 000	0,93	53178/53377/Q	53000	
		3,7500	1,2188									
		104,775	36,512	145	204	22,4	4 500	6 700	1,50	HM 807040/010/QCL7C	HM 807000	
	4,1250	1,4375										
	107,950	36,512	151	190	22,8	4 800	7 000	1,70	535/532 X	535		
	4,2500	1,4375										
	111,125	38,100	151	190	22,8	4 800	7 000	1,85	535/532 A	535		
	4,3750	1,5000										
45,237 1,7810	87,313	30,162	102	132	15	6 000	8 500	0,85	3586/3525/Q	3500		
45,242 1,7812	73,431	19,558	53,9	75	8,15	6 700	9 500	0,30	LM 102949/910/Q	LM 102900		
	2,8910	0,7700										
	77,788	19,842	53,9	69,5	7,65	6 300	9 000	0,37	LM 603049/011/Q	LM 603000		
	3,0625	0,7812										
45,618 1,7960	82,931	23,812	80,9	106	11,8	6 000	9 000	0,55	25590/25520/Q	25500		
	3,2650	0,9375										
	82,931	26,988	80,9	106	11,8	6 000	9 000	0,55	25590/25523/Q	25500		
	3,2500	1,0625										
	83,058	23,876	80,9	106	11,8	6 000	9 000	0,55	25590/25522/Q	25500		
3,2700	0,9400											

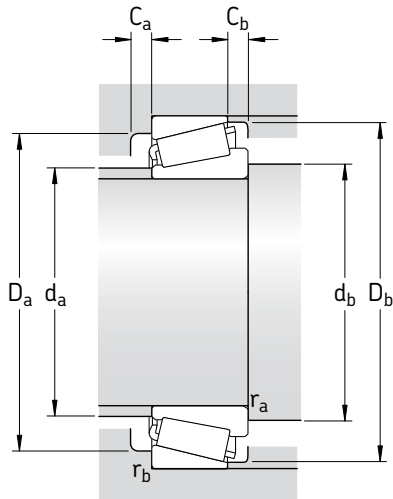

Dimensions							Abutment and fillet dimensions										Calculation factors		
d	d_1 ~	B	C	$r_{1,2}$ min	$r_{3,4}$ min	a	d_a max	d_b min	D_a min	D_a max	D_b min	C_a min	C_b min	r_a max	r_b max	e	Y	Y_0	
mm/in							mm										-		
44,450 1,7500	62,1	25,400	19,050	3,5	0,8	17	53	55,5	71	76	76	5	4,5	3	0,8	0,33	1,8	1	
		1,0000	0,7500	0,14	0,03														
	62,1	25,400	22,225	3,5	2,3	20	53	55,5	70	73	76	3	4,5	3	2	0,33	1,8	1	
		1,0000	0,8750	0,14	0,09														
	62,1	25,400	19,114	3,5	2	17	53	55,5	71	74	76	5	4,5	3	2	0,33	1,8	1	
		1,0000	0,7525	0,14	0,08														
	68,9	29,370	23,020	3,5	3,3	26	53	55,5	70	78	84	4	7	3	3	0,54	1,1	0,6	
		1,1563	0,9063	0,14	0,13														
	68,9	29,370	23,020	3,5	3,3	26	53	55,5	70	78	84	4	7	3	3	0,54	1,1	0,6	
		1,1563	0,9063	0,14	0,13														
	71,6	28,575	22,225	3,5	0,8	30	53	55,5	71	88	90	4	8,5	3	0,8	0,75	0,8	0,45	
		1,1250	0,8750	0,14	0,03														
	71,6	28,575	22,225	3,5	0,8	30	53	55,5	71	88	90	4	8,5	3	0,8	0,75	0,8	0,45	
		1,1250	0,8750	0,14	0,03														
	69,4	28,300	20,638	2	2,3	30	53	52,5	72	86	89	4	10	2	2	0,75	0,8	0,45	
		1,1142	0,8125	0,08	0,09														
	81	36,512	28,575	3,5	3,3	28	63	55,5	85	93	100	4	7,5	3	3	0,48	1,25	0,7	
		1,4375	1,1250	0,14	0,13														
	76,5	36,957	28,575	3,5	3,3	24	64	55,5	90	95,5	97	5	7,5	3	3	0,3	2	1,1	
		1,4550	1,1250	0,14	0,13														
	76,5	36,957	30,162	3,5	3,3	24	64	55,5	90	95,5	97	5	7,5	3	3	0,3	2	1,1	
		1,4550	1,1875	0,14	0,13														
45,237 1,7810	56	30,886	23,812	3,5	3,3	20	53	57	73	76	80	4	6	3	3	0,31	1,9	1,1	
		1,2160	0,9375	0,14	0,13														
45,242 1,7812	59,4	19,812	15,748	3,5	0,8	15	52	57	66	68	70	3	3,5	3	0,8	0,3	2	1,1	
		0,7800	0,6200	0,14	0,03														
	60,9	19,842	15,080	3,5	0,8	17	52	57	68	72	74	4	4,5	3	0,8	0,43	1,4	0,8	
		0,7812	0,5937	0,14	0,03														
45,618 1,7960	62,1	25,400	19,050	3,5	0,8	17	53	57	71	77	76	5	4,5	3	0,8	0,33	1,8	1	
		1,0000	0,7500	0,14	0,03														
	62,1	25,400	22,225	3,5	2,3	20	53	57	71	74	76	3	4,5	3	2	0,33	1,8	1	
		1,0000	0,8750	0,14	0,09														
	62,1	25,400	19,114	3,5	2	17	53	57	71	74,5	76	5	4,5	3	2	0,33	1,8	1	
		1,0000	0,7525	0,14	0,08														

Inch single row taper roller bearings

d **46,038 – 50,800** mm

1,8105 – 2,0000 in

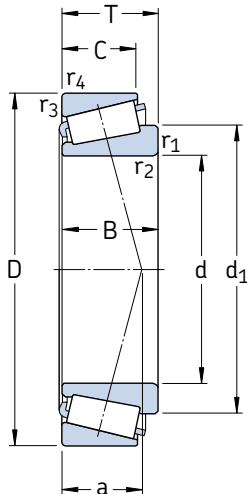

Principal dimensions			Basic load ratings		Fatigue load limit P_u	Speed ratings		Mass	Designation	Series
d	D	T	dynamic C	static C_0		Refer- ence speed	Limiting speed			
mm/in			kN	kN	r/min	kg	–	–		
46,038 1,8105	79,375	17,462	49,5	62	6,8	6 300	9 000	0,33	18690/18620/Q	18600
	3,1250	0,6875	70,4	81,5	9,3	6 000	8 500	0,49	359 S/354 X/Q	355
	85,000	20,638								
	3,3465	0,8125								
47,625 1,8750	88,900	20,637	76,5	91,5	10,4	5 600	8 000	0,55	369 S/2/362 A/2/Q	365
	3,5000	0,8125	108	146	17,3	5 000	7 500	0,95	HM 804846/2/810/2/Q	HM 804800
	95,250	30,162								
	3,7500	1,1875	151	190	22,8	5 000	7 500	1,25	528 R/522	525
	101,600	34,925								
4,0000	1,3750									
49,212 1,9375	114,300	44,450	183	224	25	4 500	6 700	2,20	65390/65320/QCL7C	65300
50,800 2,0000	82,550	21,590	72,1	100	11	6 000	8 500	0,43	LM 104949/911Q	LM 104900
	3,2500	0,8500	50,1	65,5	7,2	5 600	8 500	0,37	18790/18720/Q	18700
	85,000	17,462								
	3,3465	0,6875	76,5	91,5	10,4	5 600	8 000	0,50	368 A/362 A/Q	365
	88,900	20,637								
	3,5000	0,8125	76,5	91,5	10,4	5 600	8 000	0,58	368 A/362 X/Q	365
	90,000	25,000								
	3,5433	0,9843	110	146	17	5 300	7 500	0,85	3780/3720/Q	3700
	93,264	30,162								
	3,6718	1,1875								
	97,630	24,608	89,7	129	14,6	5 000	7 000	0,83	28678/28622 B/Q	28600
	3,8437	0,9688	145	204	22,4	4 500	6 700	1,50	HM 807046/010/QCL7C	HM 807000
	104,775	36,512								
	4,1250	1,4375	157	224	25,5	4 800	7 000	1,65	4580/2/4535/2/Q	4500
	104,775	39,688								
4,1250	1,5625	151	190	22,8	4 800	7 000	1,55	537/532 X/Q	535	
107,950	36,512									
4,2500	1,4375									

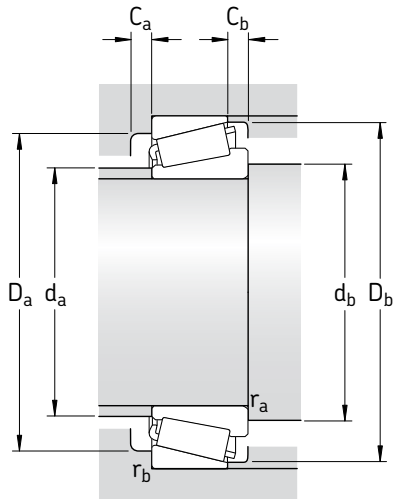

Dimensions							Abutment and fillet dimensions								Calculation factors			
d	d ₁ ~	B	C	r _{1,2} min	r _{3,4} min	a	d _a max	d _b min	D _a min	D _a max	D _b min	C _a min	C _b min	r _a max	r _b max	e	Y	Y ₀
mm/in							mm								-			
46,038 1,8105	60,3	17,462	13,495	2,8	1,5	15	53	56,5	69	72	73	3	3,5	2,5	1,5	0,37	1,6	0,9
	62,4	0,6875 17,463	0,5313 17,463	0,11 2,3	0,06 1,5	16	55	55	76	77,5	80	3	3	2	1,5	0,31	1,9	1,1
47,625 1,8750	62,4	22,225	16,513	2,3	1,3	16	55	56,5	76	82,5	80	3	3	2	1,3	0,31	1,9	1,1
	73,6	0,8750	0,6501	0,09	0,05	26	58	59	76	84	90	5	7	3	3	0,54	1,1	0,6
		1,1563	0,9063	0,14	0,13		54	71,5	87	90	94	6	7,5	7	3	0,28	2,1	1,1
49,212 1,9375	79,3	44,450	34,925	3,5	3,3	31	60	60,5	89	103	105	5	9,5	3	3	0,43	1,4	0,8
	1,7500	1,3750	0,14	0,13														
50,800 2,0000	65,1	22,225	16,510	3,5	1,3	18	57	62	72	76	77	4	4,5	3	1,3	0,3	2	1,1
	66	0,8750	0,6500	0,14	0,05	16	59	62	75	77,5	79	3	3,5	3	1,5	0,4	1,5	0,8
		0,6875	0,5313	0,14	0,06		58	62	80	82,5	83	4	4	3	1,3	0,31	1,9	1,1
	66,2	22,225	16,513	3,5	1,3	16	58	62	80	82,5	83	4	4	3	1,3	0,31	1,9	1,1
	66,2	0,8750	0,6501	0,14	0,05	21	58	62	78	81,5	83	3	5	3	2	0,31	1,9	1,1
		0,8750	0,7874	0,14	0,08		60	62	80	84,5	87	4	6	3	3	0,33	1,8	1
	71,2	30,302	23,812	3,5	3,3	22	60	62	80	84,5	87	4	6	3	3	0,33	1,8	1
	76,7	1,1930	0,9375	0,14	0,13	21	66	62	84	90,5	91	4	5	3	0,8	0,4	1,5	0,8
		24,608	19,446	3,5	0,8		66	62	84	90,5	91	4	5	3	0,8	0,4	1,5	0,8
	81	0,9688	0,7656	0,14	0,03	29	63	62	85	92,5	100	6	7,5	3	3	0,48	1,25	0,7
36,512		28,575	3,5	3,3	63		62	85	92,5	100	6	7,5	3	3	0,48	1,25	0,7	
79,5	1,4375	1,1250	0,14	0,13	27	65	62	87	92,5	98	5	6	3	3	0,33	1,8	1	
	40,157	33,338	3,5	3,3		65	62	87	92,5	98	5	6	3	3	0,33	1,8	1	
76,5	1,5810	1,3125	0,14	0,13	24	64	62	90	95,5	97	5	7,5	3	3	0,3	2	1,1	
	36,957	28,575	3,5	3,3		64	62	90	95,5	97	5	7,5	3	3	0,3	2	1,1	
	1,4550	1,1250	0,14	0,13														

Inch single row taper roller bearings

d **53,975 – 60,325** mm

2,1250 – 2,3750 in

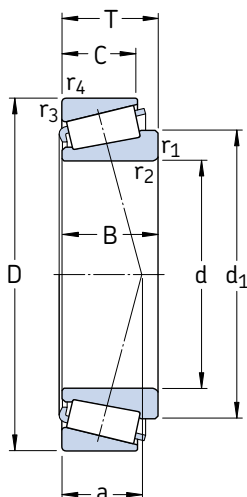

Principal dimensions			Load ratings		Fatigue load limit P_u	Speed ratings		Mass	Designation	Series
d	D	T	dynamic	static		Refer- ence speed	Limiting speed			
mm/in			kN	kN	r/min	kg	–	–		
53,975 2,1250	88,900	19,050	58,3	78	9	5 300	8 000	0,43	LM 806649/610/Q	LM 806600
	3,5000	0,7500								
	95,250	27,783	105	137	16	5 300	7 500	0,80	33895/33821/Q	33800
	3,7500	1,0938								
	95,250	27,783	105	137	16	5 300	7 500	0,80	33895/33822/Q	33800
	3,7500	1,0938								
	107,950	36,512	151	190	22,8	4 800	7 000	1,45	539/532 X	535
	4,2500	1,4375								
111,125	38,100	151	190	22,8	4 800	7 000	1,55	539/532 A	535	
4,3750	1,5000									
123,825	36,512	147	180	21,6	3 800	5 600	2,05	72212/2/72487/2/Q	72000	
4,8750	1,4375									
57,150 2,2500	96,838	21,000	80,9	102	11,6	5 000	7 500	0,59	387 A/382 A/Q	385
	3,8125	0,8268								
	96,838	21,000	80,9	102	11,6	5 000	7 500	0,59	387/382 A	385
	3,8125	0,8268								
	96,838	25,400	80,9	102	11,6	5 000	7 500	0,58	387 A/382 S/Q	385
	3,8125	1,0000								
	98,425	21,000	80,9	102	11,6	5 000	7 500	0,58	387 A/382/Q	385
	3,8750	0,8268								
	104,775	30,162	121	160	18,6	4 800	7 000	1,05	462/453 X	455
	4,1250	1,1875								
	112,712	30,162	142	204	23,6	4 300	6 300	1,45	39580/39520/Q	39500
	4,4375	1,1875								
112,712	30,162	142	204	23,6	4 300	6 300	1,40	39581/39520/Q	39500	
4,4375	1,1875									
119,985	32,750	142	204	23,6	4 300	6 300	1,75	39580/39528/Q	39500	
4,7238	1,2894									
119,985	32,750	142	204	23,6	4 300	6 300	1,75	39581/39528/Q	39500	
4,7238	1,2894									
60,325 2,3750	130,175	36,512	151	180	22,4	3 600	5 000	2,10	HM 911245/W/2/210/2/QCL7C	HM 911200
	5,1250	1,4375								
	130,175	36,512	151	180	22,4	3 600	5 000	2,10	HM 911245/W/210/QV001	HM 911200
5,1250	1,4375									

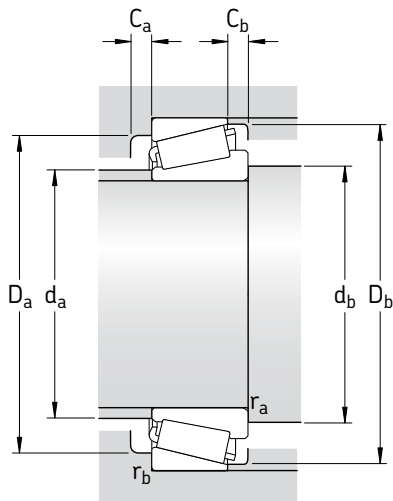

Dimensions							Abutment and fillet dimensions								Calculation factors			
d	d ₁ ~	B	C	r _{1,2} min	r _{3,4} min	a	d _a max	d _b min	D _a min	D _a max	D _b min	C _a min	C _b min	r _a max	r _b max	e	Y	Y ₀
mm/in							mm								-			
53,975 2,1250	71,6	19,050	13,492	2,3	2	21	62	64	78	79,5	84	4	5,5	2	2	0,54	1,1	0,6
		0,7500	0,5313	0,09	0,08													
	72,3	28,575	22,225	1,5	2,3	20	61	61,5	83	88	90	6	6,5	1,5	2,3	0,33	1,8	1
		1,1250	0,8750	0,06	0,09													
	72,3	28,575	22,225	1,5	0,8	20	61	61,5	83	88	90	6	6,5	1,5	0,8	0,33	1,8	1
		1,1250	0,8750	0,06	0,03													
	76,5	36,957	28,575	3,5	3,3	24	64	65,5	90	95,5	97	5	7,5	3	3	0,3	2	1,1
	1,4550	1,1250	0,14	0,13														
76,5	36,957	30,162	3,5	3,3	24	64	65,5	90	95,5	97	5	7,5	3	3	0,3	2	1,1	
	1,4550	1,1875	0,14	0,13														
88,8	32,791	25,400	3,5	3,3	36	68	65,5	93	113	114	5	11	3	3	0,75	0,8	0,45	
	1,2910	1,0000	0,14	0,13														
57,150 2,2500	74,1	21,946	15,875	3,5	0,8	17	65	68,5	87	91,5	91	5	5	3	0,8	0,35	1,7	0,9
		0,8640	0,6250	0,14	0,03													
	74,1	21,946	15,875	2,3	0,8	17	65	66,5	87	91,5	91	5	5	2	0,8	0,35	1,7	0,9
		0,8640	0,6250	0,14	0,03													
	74,1	21,946	20,274	3,5	2,3	19	65	68,5	87	87,5	91	5	5	3	2	0,35	1,7	0,9
		0,8640	0,7982	0,14	0,09													
	74,1	21,946	17,826	3,5	0,8	19	65	68,5	87	93	91	5	5	3	0,8	0,35	1,7	0,9
		0,8640	0,7018	0,14	0,03													
	78,9	29,317	24,605	2,3	3,3	24	68	67,5	91	93,5	98	4	5,5	2	3	0,33	1,8	1
		1,1542	0,9687	0,09	0,13													
88,3	30,162	23,812	3,5	3,3	23	76	68,5	100	102	107	5	6	3	3	0,33	1,8	1	
	1,1875	0,9375	0,14	0,13														
88,3	30,162	23,812	8	3,3	23	76	81	100	102	107	5	6	7	3	0,33	1,8	1	
	1,1875	0,9375	0,31	0,13														
88,3	30,162	26,949	3,5	0,8	25	76	68,5	100	114	107	5	6	3	0,8	0,33	1,8	1	
	1,1875	1,0610	0,14	0,03														
88,3	30,162	26,949	8	0,8	25	76	81	100	114	107	5	6	7	0,8	0,33	1,8	1	
	1,1875	1,0610	0,31	0,03														
60,325 2,3750	97,2	33,338	23,812	5	3,3	40	74	76	102	119	124	4	12,5	4	3	0,83	0,72	0,4
		1,3125	0,9375	0,2	0,13													
97,2	33,338	23,812	5	3,3	40	74	76	102	119	124	4	12,5	4	3	0,83	0,72	0,4	
	1,3125	0,9375	0,2	0,13														

Inch single row taper roller bearings

d **61,912 – 71,438** mm

2,4375 – 2,8125 in

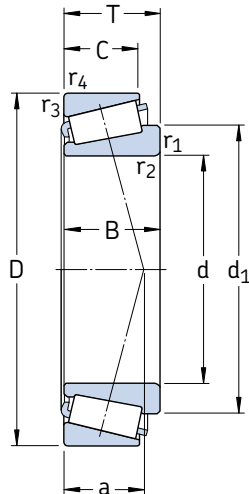

Principal dimensions			Basic load ratings		Fatigue load limit P_u	Speed ratings		Mass	Designation	Series	
d	D	T	dynamic C	static C_0		Refer- ence speed	Limiting speed				
mm/in			kN	kN	r/min	kg	–	–			
61,912 2,4375	146,050	41,275	198	236	29	3 200	4 500	3,20	H 913842/810/QCL7C	H 913800	
	5,7500	1,6250	198	236	29	3 200	4 500	3,20	H 913843/810/QCL7C	H 913800	
	146,050	41,275									
	5,7500	1,6250									
63,500 2,5000	112,712 4,4375	30,162 1,8175	123	183	21,2	4 300	6 300	1,25	3982/3920	3900	
65,088 2,5625	135,755 5,3447	53,975 2,1250	286	400	46,5	3 800	5 600	3,70	6379/K-6320/Q	6300	
66,675 2,6250	112,712 4,4375	30,162 1,8175	123	183	21,2	4 300	6 000	1,15	3984/2/3920/2/Q	3900	
	112,712 4,4375	30,162 1,8175	142	204	24	4 300	6 300	1,20	39590/39520/Q	39500	
	119,985 4,7238	32,750 1,2894	142	204	24	4 300	6 300	1,20	39590/39528/Q	39500	
	135,755 5,3447	53,975 2,1250	286	400	46,5	3 800	5 600	3,65	6386/K-6320/Q	6300	
69,850 2,7500	112,712 4,4375	25,400 1,0000	99	156	17,6	4 000	6 000	0,97	29675/29620/3/Q	29600	
	120,000 4,7244	29,795 1,1730	132	186	21,6	4 000	6 000	1,35	482/472/Q	475	
	120,000 4,7244	32,545 1,2813	154	228	26,5	4 000	6 000	1,50	47487/47420	47400	
	120,000 4,7244	32,545 1,2813	154	228	26,5	4 000	6 000	1,50	47487/47420 A/Q	47400	
	127,000 5,0000	36,512 1,4375	176	255	30,5	3 800	5 600	1,90	566/563/Q	565	
71,438 2,8125	117,475 4,6250	30,162 1,1875	123	190	22	4 000	6 000	1,25	33281/33462/Q	33000	
	136,525 5,3750	41,275 1,6250	224	290	34	3 600	5 300	2,65	H 414249/210/Q	H 414200	

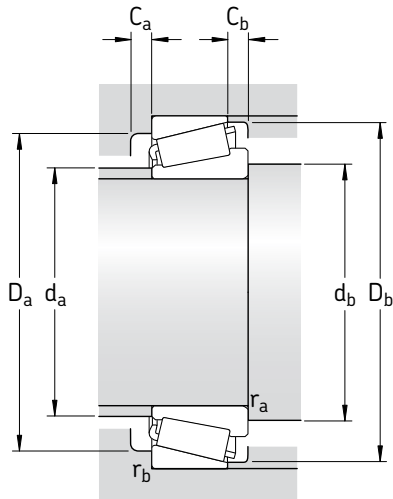

Dimensions							Abutment and fillet dimensions									Calculation factors		
d	d ₁	B	C	r _{1,2}	r _{3,4}	a	d _a	d _b	D _a	D _a	D _b	C _a	C _b	r _a	r _b	e	Y	Y ₀
							max	min	min	max	min	min	min	max	max	-		
mm/in							mm											
61,912 2,4375	109	39,688	25,400	3,5	3,3	44	83	73,5	116	135	138	6	15,5	3	3	0,79	0,76	0,4
		1,5625	1,0000	0,14	1,3													
	109	39,688	25,400	7	3,3	44	83	83	116	135	138	6	15,5	6	3	0,79	0,76	0,4
		1,5625	1,0000	0,28	1,3													
63,500 2,5000	87,8	30,048	23,812	3,5	3,3	25	75	75	96	101	105	4	6	3	3	0,4	1,5	0,8
		1,1830	0,9375	0,14	0,13													
65,088 2,5625	97,4	56,007	44,450	3,5	3,3	34	78	76,5	110	124	125	7	9,5	3	3	0,33	1,8	1
		2,2050	1,7500	0,14	0,13													
66,675 2,6250	87,8	30,048	23,812	3,5	3,3	25	75	78,5	96	101	105	4	6	3	3	0,4	1,5	0,8
		1,1830	0,9375	0,14	0,13													
	88,3	30,162	23,812	3,5	3,3	23	76	78,5	100	101	107	5	6	3	3	0,33	1,8	1
		1,1830	0,9375	0,14	0,13													
	88,3	30,162	26,949	3,5	0,8	25	76	78,5	100	112	107	5	6	3	0,8	0,33	1,8	1
	1,1830	1,0610	0,14	0,03														
	97,4	56,007	44,450	4,3	3,3	34	78	80,5	110	124	125	7	9,5	4	3	0,33	1,8	1
		2,2050	1,7500	0,17	0,13													
69,850 2,7500	94,3	25,400	19,050	1,5	3,3	26	82	77,5	100	101	108	4	6	1,5	3	0,48	1,25	0,7
		1,0000	0,7500	0,06	0,13													
	92,5	29,007	24,237	3,5	2	26	80	82	103	111	112	4	5,5	3	2	0,37	1,6	0,9
		1,1420	0,9542	0,14	0,08													
	94,3	32,545	26,195	3,5	3,3	25	81	82	105	109	113	6	6	3	3	0,35	1,7	0,9
		1,2813	1,0313	0,14	0,13													
	94,3	32,545	26,195	3,5	0,5	25	81	82	105	117	113	6	6	3	0,5	0,35	1,7	0,9
		1,2813	1,0313	0,14	0,02													
	97,6	36,170	28,575	3,5	3,3	28	83	82	109	114	119	5	7,5	3	3	0,37	1,6	0,9
		1,4240	1,1250	0,14	0,13													
71,438 2,8125	94,1	30,162	23,812	3,5	3,3	26	81	83	101	105	111	5	6	3	3	0,44	1,35	0,8
		1,1875	0,9375	0,14	0,13													
	101	41,275	31,750	3,5	3,3	30	83	83	118	123,5	129	7	9,5	3	3	0,35	1,7	0,9
		1,6250	1,2500	0,14	0,13													

Inch single row taper roller bearings

d 73,025 – 101,600 mm

2,8750 – 4,0000 in

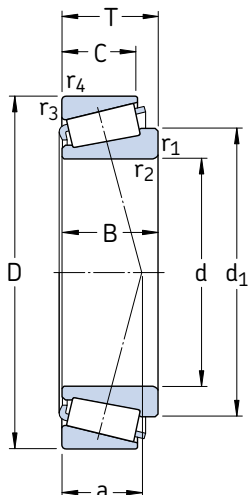

Principal dimensions			Basic load ratings		Fatigue load limit P_u	Speed ratings		Mass	Designation	Series
d	D	T	dynamic C	static C_0		Refer- ence speed	Limiting speed			
mm/in			kN	kN	r/min	kg	–	–		
73,025 2,8750	112,712	25,400	99	156	17,6	4 000	6 000	0,89	29685/2/29620/3/Q	29600
	4,4375	1,0000	123	190	22	4 000	6 000	1,20	33287/33462/Q	33000
	117,475	30,162								
	4,6250	1,1875	176	255	30,5	3 800	5 600	1,80	567/563	565
127,000	36,512									
	5,0000	1,4375								
76,200 3,0000	109,538	19,050	58,3	102	11	4 000	6 000	0,60	L 814749/710/QCL7C	L 814700
	4,3125	0,7500	138	204	24	3 800	5 300	1,90	42687/42620	42600
	127,000	30,162								
	5,0000	1,1875	165	260	30	3 400	5 000	1,90	47678/47620/Q	47600
	133,350	33,338								
	5,2500	1,3125	187	280	32,5	3 400	5 000	2,45	575/572/Q	575
	139,992	36,512								
		5,5115	1,4375	260	335	38	2 800	4 000	4,40	9285/9220/CL7C
161,925	49,212									
	6,3750	1,9375								
82,550 3,2500	139,992	36,512	187	280	32,5	3 400	5 000	2,20	580/572/Q	575
	5,5115	1,4375	220	320	35,5	3 200	4 800	2,80	663/653/Q	655
	146,050	41,275								
	5,7500	1,6250								
88,900 3,5000	152,400	39,688	194	305	34,5	3 000	4 500	2,80	593/592 A/Q	595
	6,0000	1,5625								
92,075 3,6250	152,400	39,688	194	305	34,5	3 000	4 500	2,70	598/592 A/Q	595
	6,0000	1,5625								
95,250 3,7500	146,050	33,338	168	280	31,5	3 200	4 500	1,90	47896/47820/Q	47800
	5,7500	1,3125	194	305	34,5	3 000	4 500	2,55	594/592 A/Q	595
	152,400	39,688								
	6,0000	1,5625	194	305	34,5	3 000	4 500	2,55	594 A/592 A/Q	595
	152,400	39,688								
	6,0000	1,5625	233	365	39	2 800	4 000	3,80	683/672	675
168,275	41,275									
	6,6250	1,6250								
101,600 4,0000	168,275	41,275	233	365	39	2 800	4 000	3,45	687/672	675
	6,6250	1,6250								

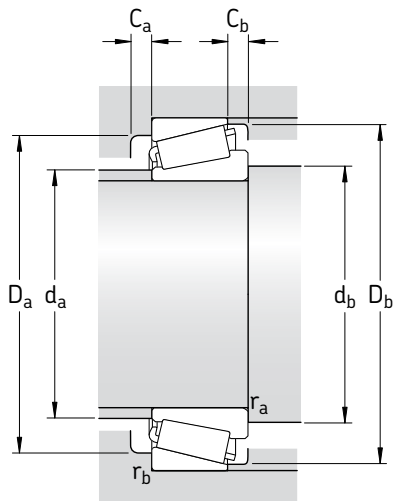

Dimensions							Abutment and fillet dimensions									Calculation factors		
d	d ₁	B	C	r _{1,2}	r _{3,4}	a	d _a	d _b	D _a	D _a	D _b	C _a	C _b	r _a	r _b	e	Y	Y ₀
							mm									-		
73,025 2,8750	94,3	25,400	19,050	3,5	3,3	26	82	85	100	100	108	4	6	3	3	0,48	1,25	0,7
		1,0000	0,7500	0,14	0,13													
	94,1	30,162	23,812	3,5	3,3	26	81	85	101	105	111	5	6	3	3	0,44	1,35	0,8
	1,1875	0,9375	0,14	0,13														
	97,6	36,170	28,575	3,5	3,3	28	83	85	109	114	119	5	7,5	3	3	0,37	1,6	0,9
	1,4240	1,1250	0,14	0,13														
76,200 3,0000	94,8	19,050	15,083	1,5	1,5	24	85	85	98	100,5	105	3	3,5	1,5	1,5	0,5	1,2	0,7
		0,7500	0,5938	0,06	0,06													
	101	31,000	22,225	3,5	3,3	27	88	89,5	112	114	120	5	7,5	3	3	0,43	1,4	0,8
		1,2205	0,8750	0,14	0,13													
	108	33,338	26,195	6,4	3,3	29	93	96	117	120,5	126	5	7	6	3	0,4	1,5	0,8
		1,3125	1,0313	0,25	0,13													
	110	36,098	28,575	3,5	3,3	31	94	89,5	120	127	131	5	7,5	3	3	0,4	1,5	0,8
	1,4212	1,1250	0,14	0,13														
	122	46,068	31,750	3,5	3,3	47	93	90	128	148,5	153	7	17	3	3	0,72	0,84	0,45
	1,8125	1,2500	0,14	0,13														
82,550 3,2500	110	36,098	28,575	3,5	3,3	31	94	94,5	120	127	131	5	7,5	3	3	0,4	1,5	0,8
		1,4212	1,1250	0,14	0,13													
	114	41,275	31,750	3,5	3,3	32	96	94,5	125	133	138	6	9	3	3	0,4	1,5	0,8
	1,6250	1,2500	0,14	0,13														
88,900 3,5000	122	36,322	30,162	3,5	3,3	37	101	102,5	128	141	141	4	9,5	3	3	0,44	1,35	0,8
		1,4300	1,1875	0,14	0,13													
92,075 3,6250	122	36,322	30,162	3,5	3,3	37	101	106	128	141	141	4	9,5	3	3	0,44	1,35	0,8
		1,4300	1,1875	0,14	0,13													
95,250 3,7500	120	34,925	26,195	3,5	3,3	32	105	107	128	138,5	141	6	7	3	3	0,44	1,35	0,8
		1,3750	1,0313	0,14	0,13													
	121	36,322	30,162	3,5	3,3	37	104	107	128	139	141	4	9,5	3	3	0,44	1,35	0,8
		1,4300	1,1875	0,14	0,13													
	121	36,322	30,162	5	3,3	37	104	112	128	139	141	4	9,5	4	3	0,44	1,35	0,8
	1,4300	1,1875	0,2	0,13														
	133	41,275	30,162	3,5	3,3	38	114	107	143	154,5	157	6	11	3	3	0,48	1,25	0,7
	1,6250	1,1875	0,14	0,13														
101,600 4,0000	133	41,275	30,162	3,5	3,3	38	114	113	143	157	157	6	11	3	3	0,48	1,25	0,7
		1,6250	1,1875	0,14	0,13													

Inch single row taper roller bearings

d **107,950 – 179,934** mm

4,2500 – 7,0840 in

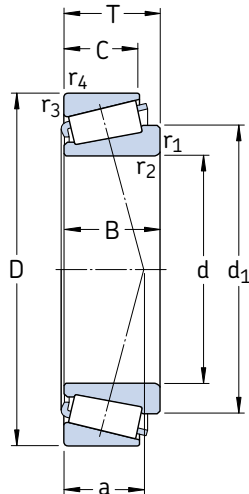

Principal dimensions			Basic load ratings		Fatigue load limit P_u	Speed ratings		Mass	Designation	Series
d	D	T	dynamic C	static C_0		Refer- ence speed	Limiting speed			
mm/in			kN		kN	r/min		kg	–	–
107,950 4,2500	158,750 6,2500	23,020 0,9063	101	163	18,3	2 800	4 300	1,40	37425/2/37625/2/Q	37000
114,300 4,5000	177,800 7,0000	41,275 1,6250	251	415	42,5	2 600	3 800	3,60	64450/64700	64000
	180,975 7,1250	34,925 1,3750	183	280	30	2 600	3 800	2,95	68450/68712	68000
127,000 5,0000	182,562 7,1875	39,688 1,5625	229	440	44	2 400	3 600	3,30	48290/48220/Q	48200
	196,850 7,7500	46,038 1,8135	319	585	60	2 200	3 400	5,20	67388/67322	67300
133,350 5,2500	177,008 6,9688	25,400 1,0000	134	280	28	2 400	3 600	1,80	L 327249/210	L 327200
	196,850 7,7500	46,038 1,8135	319	585	60	2 200	3 400	4,80	67391/67322	67300
139,700 5,5000	236,538 9,3125	57,150 2,2500	512	850	86,5	1 900	2 800	10,0	HM 231132/110	HM 231100
149,225 5,8750	236,538 9,3125	57,150 2,2500	512	850	86,5	1 900	2 800	10,0	HM 231148/110	HM 231100
152,400 6,0000	222,250 8,7500	46,830 1,8437	330	630	62	2 000	3 000	5,90	M 231649/610/VQ051	M 231600
158,750 6,2500	205,583 8,0938	23,812 0,9375	138	280	27	2 000	3 000	1,95	L 432348/310	L 432300
	205,583 8,0938	23,812 0,9375	138	280	27	2 000	3 000	1,95	L 432349/310	L 432300
177,800 7,0000	227,012 8,9375	30,162 1,1875	187	425	40	1 800	2 800	3,00	36990/36920	36900
178,595 7,0313	265,112 10,4375	51,595 2,0313	495	880	86,5	1 700	2 400	9,60	M 336948/912	M 336900
179,934 7,0840	265,112 10,4375	51,595 2,0313	495	880	86,5	1 700	2 400	9,40	M 336949/912	M 336900

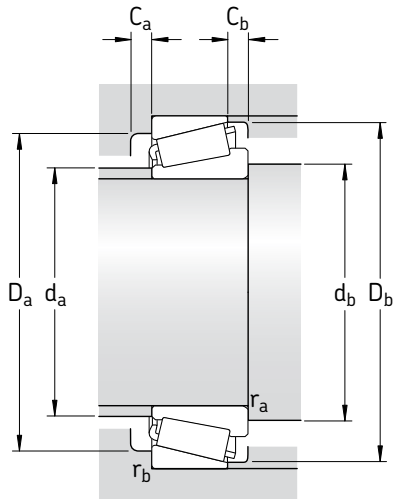

Dimensions							Abutment and fillet dimensions							Calculation factors				
d	d ₁	B	C	r _{1,2} min	r _{3,4} min	a	d _a max	d _b min	D _a min	D _a max	D _b min	C _a min	C _b min	r _a max	r _b max	e	Y	Y ₀
mm/in							mm							-				
107,950 4,2500	132	21,438 0,8440	15,875 0,6250	3,5 0,14	3,3 0,13	37	120	121	140	145	149	4	7	3	3	0,6	1	0,6
114,300 4,5000	146	41,275 1,6250	30,162 1,1875	3,5 0,14	3,3 0,13	42	126	127	155	166	171	6	11	3	3	0,52	1,15	0,6
	144	31,750 1,2500	25,400 1,0000	3,5 0,14	3,3 0,13	40	129	127	158	170	170	4	9,5	3	3	0,5	1,2	0,7
127,000 5,0000	155	38,100 1,5000	33,338 1,3125	3,5 0,14	3,3 0,13	34	140	140	165	168,5	174	6	6	3	3	0,3	2	1,1
	164	46,038 1,8125	38,100 1,5000	3,5 0,14	3,3 0,13	39	146	140	177	185	189	7	7,5	3	3	0,35	1,7	0,9
133,350 5,2500	155	26,195 1,0313	20,638 0,8125	1,5 0,06	1,5 0,06	29	145	141	165	188	170	5	4,5	1,5	1,5	0,33	1,8	1
	164	46,038 1,8125	38,100 1,5000	8 0,31	3,3 0,13	39	146	161	177	185	189	7	7,5	7	3	0,35	1,7	0,9
139,700 5,5000	187	56,642 2,2300	44,450 1,7500	3,5 0,14	3,3 0,13	45	166	153	210	225	223	9	12,5	3	3	0,31	1,9	1,1
149,225 5,8750	187	56,642 2,2300	44,450 1,7500	6,4 0,25	3,3 0,13	45	166	171	210	225	223	9	12,5	6	3	0,31	1,9	1,1
152,400 6,0000	186	46,830 1,8437	34,925 1,3750	3,5 0,14	1,5 0,06	40	169	165	200	214	210	7	11,5	3	1,5	0,33	1,8	1
158,750 6,2500	182	23,812 0,9375	18,258 0,7188	4,8 0,19	1,5 0,06	33	172	175	194	197	197	5	5,5	4	1,5	0,35	1,7	0,9
	182	23,812 0,9375	18,258 0,7188	1,5 0,06	1,5 0,06	33	172	167	194	197	197	5	5,5	1,5	1,5	0,35	1,7	0,9
177,800 7,0000	203	30,162 1,1875	23,020 0,9063	1,5 0,06	1,5 0,06	43	190	186	212	219	220	5	7	1,5	1,5	0,44	1,35	0,8
178,595 7,0313	217	57,150 2,2500	38,895 1,5313	3,3 0,13	3,3 0,13	47	196	191	240	253	251	9	12,5	3	3	0,33	1,8	1
179,934 7,0840	217	57,150 2,2500	38,895 1,5313	3,3 0,13	3,3 0,13	47	196	193	240	253	251	9	12,5	3	3	0,33	1,8	1

Inch single row taper roller bearings

d 187,325 – 231,775 mm

7,3750 – 9,1250 in

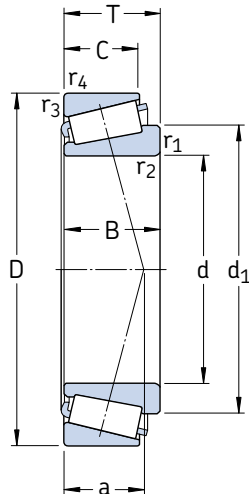

Principal dimensions			Basic load ratings		Fatigue load limit P_u	Speed ratings		Mass kg	Designation	Series
d	D	T	dynamic C	static C_0		Refer- ence speed	Limiting speed			
mm/in			kN		kN	r/min		kg	–	–
187,325 7,3750	282,575 11,1250	50,800 2,0000	402	695	67	1 600	2 200	9,80	87737/87111	87000
190,475 7,4990	279,400 11,0000	52,388 2,0625	523	980	95	1 600	2 200	9,50	M 239449/410	M 239400
190,500 7,5000	282,575 11,1250	50,800 2,0000	402	695	67	1 600	2 200	9,60	87750/87111	87000
191,237 7,5290	279,400 11,0000	52,388 2,0625	523	980	95	1 600	2 200	9,20	M 239448 A/410	M 239400
196,850 7,7500	241,300	23,812	154	315	29	1 700	2 600	2,00	LL 639249/210	LL 639200
	9,5000	0,9375	154	315	29	1 700	2 600	2,00	LL 639249/2/210/4	LL 639200
	241,300	23,812	275	655	58,5	1 600	2 400	5,30	LM 739749/710/VE174	LM 739700
	9,5000	0,9375								
	257,175	39,688								
	10,1250	1,5625								
200,025 7,8750	276,225 10,8750	42,862 1,6875	391	780	72	1 500	2 200	7,70	LM 241147/110/QVQ051	LM 241100
203,987 8,0310	276,225 10,8750	42,862 1,6875	391	780	72	1 500	2 200	7,25	LM 241148/110/QVQ051	LM 241100
206,375 8,1250	282,575 11,1250	46,038 1,8125	380	830	76,5	1 500	2 200	8,60	67985/67920/HA3VQ117	67900
216,408 8,5200	285,750 11,2500	46,038 1,8125	380	850	76,5	1 500	2 200	7,85	LM 742747/710	LM 742700
216,713 8,5320	285,750 11,2500	46,038 1,8125	380	850	76,5	1 500	2 200	7,85	LM 742747 A/710	LM 742700
230,188 9,0625	317,500 12,5000	47,625 1,8750	523	980	90	1 300	2 000	10,5	LM 245846/810	LM 245800
231,775 9,1250	300,038	33,338	216	425	39	1 400	2 000	5,30	544091/2B/118 A/2B	544000
	11,8125	1,3125	523	980	90	1 300	2 000	10,5	LM 245848/810	LM 245800
	317,500	47,625								
	12,5000	1,8750								

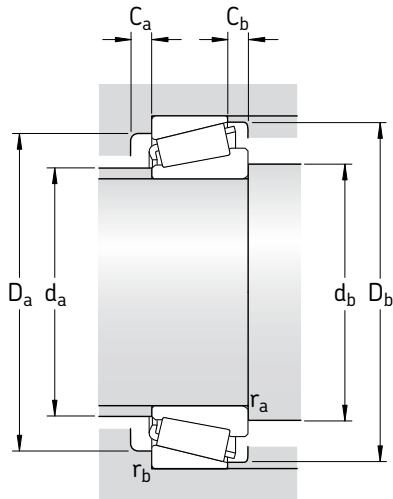

Dimensions							Abutment and fillet dimensions								Calculation factors			
d	d ₁	B	C	r _{1,2}	r _{3,4}	a	d _a	d _b	D _a	D _a	D _b	C _a	C _b	r _a	r _b	e	Y	Y ₀
mm/in							mm								-			
187,325 7,3750	233	47,625 1,8750	36,512 1,4375	3,5 0,14	3,3 0,13	55	213	201	253	271	267	6	14	3	3	0,43	1,4	0,8
190,475 7,4990	232	57,150 2,2500	41,275 1,6250	3,3 0,13	3,3 0,13	49	211	203	254	265	266	9	11	3	3	0,35	1,7	0,9
190,500 7,5000	233	47,625 1,8750	36,512 1,4375	3,5 0,14	3,3 0,13	55	213	205	253	268	267	6	14	3	3	0,43	1,4	0,8
191,237 7,5290	232	58,738 2,3125	41,275 1,6250	3,3 0,13	3,3 0,13	49	211	204	254	265	266	9	11	3	3	0,35	1,7	0,9
196,850 7,7500	217	23,017 0,9062	17,462 0,6875	1,5 0,06	1,5 0,06	41	207	204	232	233	235	5	6	1,5	1,5	0,43	1,4	0,8
	217	23,017 0,9062	17,462 0,6875	1,5 0,06	1,5 0,06	41	207	204	232	233	235	5	6	1,5	1,5	0,43	1,4	0,8
	229	39,688 1,5625	30,162 1,1875	3,5 0,14	3,3 0,13	50	236	210	236	245	247	8	9,5	3	3	0,44	1,35	0,8
200,025 7,8750	237	46,038 1,8125	34,133 1,3438	3,5 0,14	3,3 0,13	45	220	213	257	261	265	6	8,5	3	3	0,31	1,9	1,1
203,987 8,0310	237	46,038 1,8125	34,133 1,3438	3,5 0,14	3,3 0,13	45	220	217	257	261	265	6	8,5	3	3	0,31	1,9	1,1
206,375 8,1250	247	46,038 1,8125	36,512 1,4375	3,5 0,14	3,3 0,13	62	222	220	254	268	272	8	9,5	3	3	0,5	1,2	0,7
216,408 8,5200	253	49,212 1,9375	34,924 1,3750	3,5 0,14	3,3 0,13	60	230	230	261	271	277	7	11	3	3	0,48	1,25	0,7
216,713 8,5320	253	49,212 1,9375	34,924 1,3750	3,5 0,14	3,3 0,13	60	230	230	261	271	277	7	11	3	3	0,48	1,25	0,7
230,188 9,0625	268	52,388 2,0625	36,512 1,4375	3,3 0,13	3,3 0,13	49	249	243	296	303	304	8	11	3	3	0,31	1,9	1,1
231,775 9,1250	260	31,750 1,2500	23,812 0,9375	3,5 0,13	3,3 0,13	49	248	246	278	285	284	5	9,5	3	3	0,4	1,5	0,8
	268	52,388 2,0625	36,512 1,4375	3,3 0,13	3,3 0,13	49	249	245	296	303	304	8	11	3	3	0,31	1,9	1,1

Inch single row taper roller bearings

d 255,600 – 488,950 mm

10,0630 – 19,2500 in

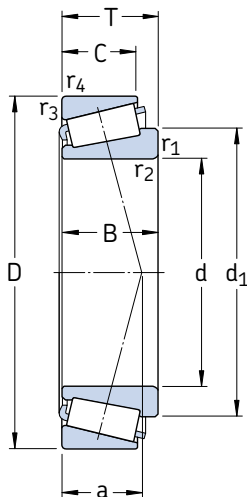

Principal dimensions			Basic load ratings		Fatigue load limit P_u	Speed ratings		Mass	Designation	Series
d	D	T	dynamic C	static C_0		Refer- ence speed	Limiting speed			
mm/in			kN		kN	r/min		kg	–	–
255,600 10,0630	342,900 13,5000	57,150 2,2500	594	1 220	110	1 200	1 800	14,0	M 349547/510	M 349500
257,175 10,1259	342,900 13,5000	57,150 2,2500	594	1 220	110	1 200	1 800	14,0	M 349549/510/VE174	M 349500
	358,775 14,1250	71,438 2,8125	842	1 760	156	1 200	1 700	20,5	M 249747/710	M 249700
263,525 10,3750	325,438 12,8125	28,575 1,1250	220	550	48	1 300	1 800	53,0	38880/38820	38800
292,100 11,5000	374,650 14,7500	47,625 1,8750	501	1 140	98	1 100	1 600	12,0	L 555249/210	L 555200
	374,650 14,7500	47,625 1,8750	501	1 140	98	1 100	1 600	12,0	L 555249/210/VE174	L 555200
304,800 12,0000	393,700 15,5000	50,800 2,0000	528	1 220	104	1 000	1 500	14,5	L 357049/010/VE174	L 357000
343,154 13,5100	450,850 17,7500	66,675 2,6250	935	2 200	180	900	1 300	28,0	LM 361649 A/610	LM 361600
346,075 13,6250	488,950 19,2500	95,250 3,7500	1 420	3 150	255	850	1 200	55,0	HM 262749/710	HM 262700
381,000 15,0000	479,425 18,8750	49,213 1,9375	594	1 500	120	800	1 200	20,0	L 865547/512	L 865500
384,175 15,1250	546,100 21,5000	104,775 4,1250	1 870	4 150	320	750	1 100	77,0	HM 266449/410	HM 266400
403,225 15,8750	460,375 18,1250	28,575 1,1250	246	765	58,5	800	1 200	6,70	LL 566848/810/HA1	LL 566800
406,400 16,0000	549,275 21,6250	85,725 3,3750	1 380	3 050	236	700	1 000	53,5	LM 567949/910/HA1	LM 567900
457,200 18,0000	603,250 23,7500	85,725 3,3750	1 450	3 400	265	630	950	61,5	LM 770949/910	LM 770900
488,950 19,2500	634,873 24,9950	84,138 3,3125	1 450	3 650	265	600	850	63,5	LM 772748/710/HA1	LM 772700

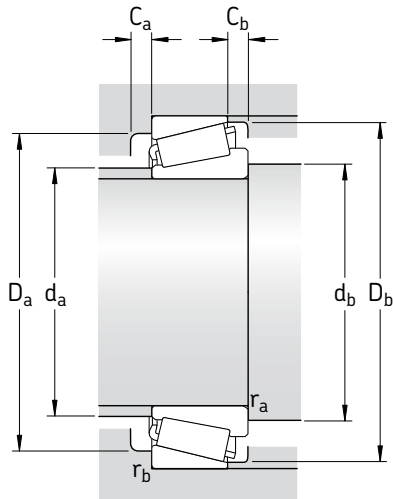

Dimensions							Abutment and fillet dimensions								Calculation factors			
d	d ₁	B	C	r _{1,2} min	r _{3,4} min	a	d _a max	d _b min	D _a min	D _a max	D _b min	C _a min	C _b min	r _a max	r _b max	e	Y	Y ₀
mm/in							mm								-			
255,600 10,0630	297	63,500 2,5000	44,450 1,7500	1,5 0,06	3,3 0,13	60	274	267	318	328	331	9	12,5	1,5	3	0,35	1,7	0,9
257,175 10,1250	297	57,150 2,2500	44,450 1,7500	6,4 0,25	3,3 0,13	60	274	289	318	328	331	9	12,5	6	3	0,35	1,7	0,9
	303	76,200 3,0000	53,975 2,1250	1,5 0,06	3,3 0,13	64	276	269	326	343	343	11	17	1,5	3	0,33	1,8	1
263,525 10,3750	294	28,575 1,1250	25,400 1,0000	1,5 0,06	1,5 0,06	49	282	275	307	315	313	4	3	1,5	1,5	0,37	1,6	0,9
292,100 11,5000	331	47,625 1,8750	34,925 1,3750	3,5 0,14	3,3 0,13	65	311	308	350	359	361	8	12,5	3	3	0,4	1,5	0,8
	331	47,625 1,8750	34,925 1,3750	3,5 0,14	3,3 0,13	65	311	308	350	359	361	8	12,5	3	3	0,4	1,5	0,8
304,800 12,0000	348	50,800 2,0000	38,100 1,5000	6,4 0,25	3,3 0,13	64	328	337	368	378	379	7	12,5	6	3	0,35	1,7	0,9
343,154 13,5100	394	66,675 2,6250	52,388 2,0625	8,5 0,33	3,5 0,14	75	365	385	417	433	434	12	14	8	3	0,35	1,7	0,9
346,075 13,6250	413	95,250 3,7500	74,612 2,9375	6,4 0,25	3,3 0,13	88	379	378	442	472	467	12	21	6	3	0,33	1,8	1
381,000 15,0000	431	47,625 1,8750	34,925 1,3750	6,4 0,25	3,3 0,13	92	406	413	448	462	463	9	14	6	3	0,5	1,2	0,7
384,175 15,1250	458	104,775 4,1250	82,550 3,2500	6,4 0,25	6,4 0,25	96	418	416	492	514	520	15	22	6	6	0,33	1,8	1
403,225 15,8750	430	28,575 1,1250	20,638 0,8125	3,5 0,14	3,3 0,13	70	417	420	445	443	448	6	7,5	3	3	0,4	1,5	0,8
406,400 16,0000	471	84,138 3,3125	61,962 2,4375	6,4 0,25	3,3 0,13	100	434	438	502	532	526	13	23,5	6	3	0,4	1,5	0,8
457,200 18,0000	525	84,138 3,3125	60,325 2,3750	6,4 0,25	3,3 0,13	115	486	489	553	586	580	13	25	6	3	0,46	1,3	0,7
488,950 19,2500	560	84,138 3,3125	61,912 2,4375	6,4 0,25	3,3 0,13	124	519	520	584	618	613	13	22	6	3	0,48	1,25	0,7

Inch single row taper roller bearings

d **498,475 – 838,200** mm

19,6250 – 33,0000 in

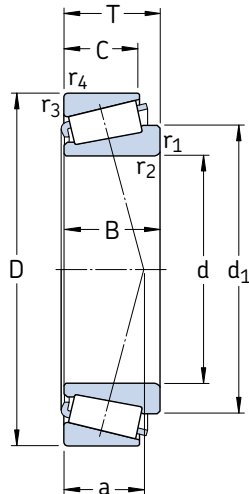

Principal dimensions			Basic load ratings		Fatigue load limit P_u	Speed ratings		Mass	Designation	Series
d	D	T	dynamic C	static C_0		Refer- ence speed	Limiting speed			
mm/in			kN		kN	r/min	kg	–	–	
498,475 19,6250	634,873 24,9950	80,962 3,1875	1 470	3 650	270	600	850	59,5	EE 243196/250/HA2	243000
558,800 22,0000	736,600 29,0000	88,108 3,4688	1 830	4 150	305	500	750	92,5	EE 843220/290	843000
	736,600 29,0000	104,775 4,1250	2 330	5 700	405	500	750	115	LM 377449/410	LM 377400
609,600 24,0000	787,400 31,0000	93,662 3,6875	2 160	5 300	380	450	670	110	EE 649240/310	649000
749,300 29,5000	990,600 39,0000	159,500 6,2795	4 570	12 000	750	340	500	330	LM 283649/610/HA1	LM 283600
760,000 29,9183	889,000 35,0000	69,850 2,7500	1 230	3 800	255	380	560	67,5	LL 483448/418	LL 483400
	889,000 35,0000	88,900 3,5000	1 870	5 850	380	360	530	94,0	L 183448/410	L 183400
762,000 30,0000	889,000 35,0000	69,850 2,7500	1 230	3 800	255	380	560	66,5	LL 483449/418	LL 483400
	889,000 35,0000	88,900 3,5000	1 870	5 850	380	360	530	94,0	L 183449/410	L 183400
838,200 33,0000	1 041,400 41,0000	93,662 3,6875	1 900	4 800	320	320	460	160	EE 763330/410	763000

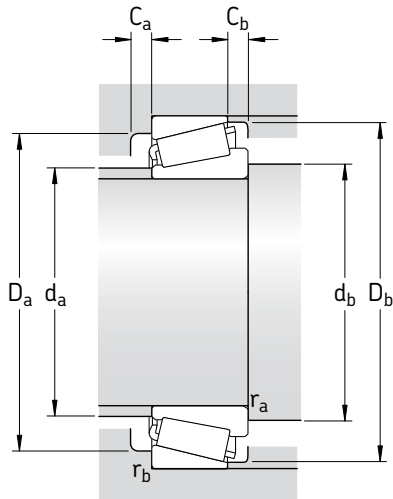

Dimensions				Abutment and fillet dimensions										Calculation factors					
d	d ₁	B	C	r _{1,2}	r _{3,4}	a	d _a	d _b	D _a	D _a	D _b	C _a	C _b	r _a	r _b	e	Y	Y ₀	
mm/in							mm										-		
498,475 19,6250	556	80,962 3,1875	63,500 2,5000	6,4 0,25	3,3 0,13	98	522	530	590	618	610	14	17	6	3	0,35	1,7	0,9	
558,800 22,0000	637	88,108 3,4686	63,500 2,5000	6,4 0,25	6,4 0,25	111	600	590	689	704	707	13	24,5	6	6	0,35	1,7	0,9	
	640	104,775 4,1250	80,962 3,1875	6,4 0,25	6,4 0,25	130	595	590	680	704	707	17	23,5	6	6	0,35	1,7	0,9	
609,600 24,0000	687	93,662 3,6875	69,850 2,7500	6,4 0,25	6,4 0,25	125	643	642	732	755	755	17	23,5	6	6	0,37	1,6	0,9	
749,300 29,5000	858	160,338 6,3125	123,000 4,8425	6,4 0,25	6,4 0,25	165	793	781	910	958	953	22	36,6	6	6	0,33	1,8	1	
760,000 29,9183	819	69,850 2,7500	50,800 2,0000	3,3 0,13	3,3 0,13	132	785	777	844	872	858	13	19	3	3	0,37	1,6	0,9	
	822	88,900 3,5000	72,000 2,8346	3,3 0,13	3,3 0,13	123	785	777	854	872	872	16	16,5	3	3	0,3	2	1,1	
762,000 30,0000	819	69,850 2,7500	50,800 2,0000	3,3 0,13	3,3 0,13	132	785	779	844	872	858	13	19	3	3	0,37	1,6	0,9	
	822	88,900 3,5000	72,000 2,8346	3,3 0,13	3,3 0,13	123	785	779	854	872	872	16	16,5	3	3	0,3	2	1,1	
838,200 33,0000	925	88,900 3,5000	66,675 2,6250	6,4 0,25	6,4 0,25	177	894	870	975	1010	1001	10	26,5	6	6	0,44	1,35	0,8	

**Metric single row taper roller bearings
with flanged outer ring**
d 35 – 65 mm

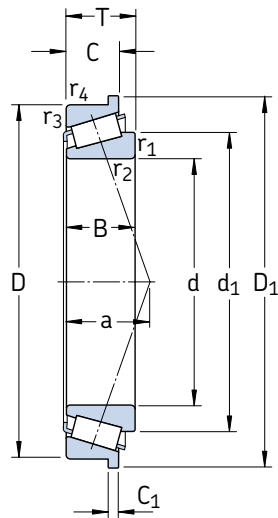

Principal dimensions			Basic load ratings		Fatigue load limit P_u	Speed ratings		Mass	Designation
d	D	T	dynamic	static		Refer- ence speed	Limiting speed		
mm			kN		kN	r/min		kg	–
35	80	22,75	72,1	73,5	8,3	6 700	9 000	0,52	30307 RJ2/Q
	68	19	52,8	71	7,65	7 000	9 500	0,27	32008 XR/QVA621
40	80	19,75	61,6	68	7,65	6 300	8 500	0,42	30208 RJ2/Q
	100	38,25	134	176	20	4 800	6 700	1,50	32309 BRJ2/QCL7C
55	120	45,5	216	260	30	4 300	5 600	2,50	* 32311 BRJ2/QCL7C
65	110	34	142	208	24	4 300	5 600	1,30	33113 R/Q
	140	36	194	228	27,5	3 600	4 800	2,40	30313 RJ2

* SKF Explorer bearing

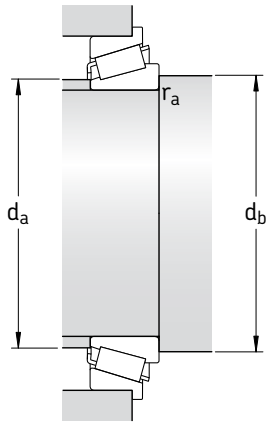

Dimensions									Abutment and fillet dimensions			Calculation factors		
d	d ₁ ~	D ₁	B	C	C ₁	r _{1,2} min	r _{3,4} min	a	d _a max	d _b min	r _a max	e	Y	Y ₀
mm									mm			-		
35	54,5	85	21	18	4,5	2	1,5	16	46	44	1,5	0,31	1,9	1,1
40	54,2	72	19	14,5	3,5	1	1	15	46	46	1	0,37	1,6	0,9
	57,5	85	18	16	4	1,5	1,5	16	49	47	1	0,37	1,6	0,9
45	74,8	106	36	30	7	2	1,5	30	55	54	1,5	0,54	1,1	0,6
55	90,5	127	43	35	8	2,5	2	36	67	65	2	0,54	1,1	0,6
65	87,9	116	34	26,5	5,5	1,5	1,5	26	74	72	1	0,4	1,5	0,8
	98,3	147	33	28	6	3	2,5	28	84	77	2	0,35	1,7	0,9



Paired single row taper roller bearings

Matched bearing pairs	672
Face-to-face arrangement	673
Back-to-back arrangement.....	673
Tandem arrangement	673
Bearing data – general	674
Dimensions.....	674
Tolerances.....	674
Axial internal clearance	675
Misalignment.....	676
Cages.....	676
Minimum load.....	676
Equivalent dynamic bearing load.....	676
Equivalent static bearing load.....	676
Supplementary designations.....	677
Fits for bearing pairs	677
Determining the load acting on bearing pairs	678
Bearing pairs arranged face-to-face.....	678
Bearing pairs arranged back-to-back.....	678
Product tables	680
Single row taper roller bearings, paired face-to-face	680
Single row taper roller bearings, paired back-to-back.....	688
Single row taper roller bearings, paired in tandem	692

Matched bearing pairs

For bearing arrangements where the load carrying capacity of a single taper roller bearing is inadequate, or where the shaft has to be axially located in both directions with a given positive or negative axial play, the bearings listed in the section “Single row taper roller bearings”, starting on **page 605**, can be supplied as matched pairs (→ **fig. 1**) arranged

- face-to-face
- back-to-back
- in tandem.

Matched bearing sets provide an economic solution to many bearing arrangement problems and offer many advantages, including

- simple mounting, since calibration of intermediate rings is not required, so that mounting errors are avoided
- exact axial location of the shaft; the axial play is determined during manufacture
- high radial and axial load carrying capacity
- simple maintenance; the lubricant can be introduced via the annular groove and lubrication holes in the intermediate ring.

SKF can supply matched bearing sets in the arrangements shown in **fig. 2** and described in the following. The bearing pairs shown in the product tables, starting on **page 680**, are only part of the comprehensive SKF programme. Other bearing sets can be supplied to order.

Fig. 1

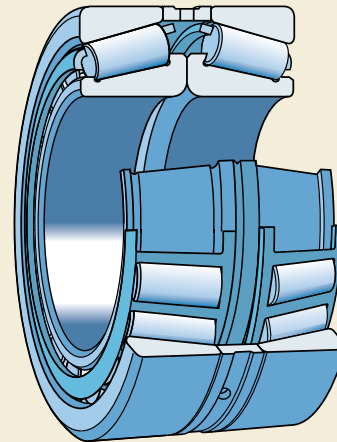
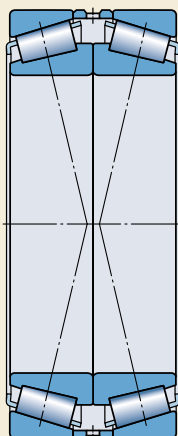
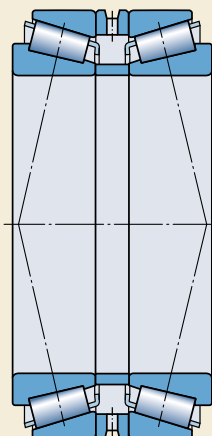

Fig. 2



a



b

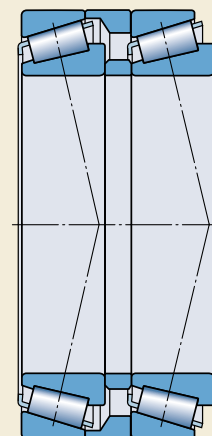

c

Face-to-face arrangement

In bearing pairs where the bearings are matched face-to-face, an intermediate ring is positioned between the two outer rings (→ **fig. 2a**) so that production is relatively simple. In face-to-face arrangements, the load lines converge towards the bearing axis. Axial loads acting in both directions can be accommodated by each bearing in one direction.

Back-to-back arrangement

In bearing pairs where the bearings are arranged back-to-back (→ **fig. 2b**) an intermediate ring is positioned both between the two inner rings and between the two outer rings. This is a more expensive production than required for the face-to-face sets. In back-to-back arrangements, the load lines diverge towards the bearing axis, thus providing relatively rigid bearing arrangements, which can also take up tilting moments. Axial loads acting in both directions can be accommodated by each bearing in one direction.

Tandem arrangement

Bearing pairs where the bearings are arranged in tandem are seldom used and also require an intermediate ring between both inner rings and both outer rings (→ **fig. 2c**). Because the load lines of the two bearings are in parallel, radial and axial loads will be equally distributed over the two bearings. The bearing pair can only accommodate axial loads acting in one direction and should be adjusted against a third bearing that can accommodate the axial loads acting in the opposite direction.

Bearing data – general

the deviation of a single total abutment width of a bearing pair from the nominal.

Dimensions

The boundary dimensions of the individual bearings with series designations of a set are in accordance with ISO 355:1977.

Tolerances

The matched bearing sets are made to Normal tolerances as for the single bearings. The values for the Normal tolerances conform to ISO 492:2002 and are listed in **table 6** on **page 128**. The tolerance for the total width of the set, although not standardized, can be found in **table 1**. In the table Δ_{TSD} designates

Table 1

Total width tolerances of matched single row metric taper roller bearings													
Bore diameter d over incl.		Total width tolerance Δ_{TSD} of matched bearings of series											
		329		320 X		330		331, 302, 322, 332		303, 323		313 (X)	
		high	low	high	low	high	low	high	low	high	low	high	low
mm		μm											
-	30	-	-	+550	+100	-	-	+550	+100	+600	+150	+500	+50
30	40	-	-	+550	+100	-	-	+600	+150	+600	+150	+550	+50
40	50	-	-	+600	+150	-	-	+600	+200	+600	+200	+550	+50
50	65	-	-	+600	+150	-	-	+600	+200	+650	+200	+550	+100
65	80	-	-	+600	+200	-	-	+650	+200	+700	+200	+600	+100
80	100	+750	-150	+650	-250	+800	-50	+700	-200	+700	-100	+600	-300
100	120	+750	-150	+700	-200	+800	-100	+700	-200	+750	-150	+600	-300
120	140	+1 100	-200	+1 000	-300	+1 100	-200	+1 000	-300	+1 100	-200	+950	-350
140	160	+1 150	-150	+1 050	-250	+1 100	-200	+1 050	-250	+1 150	-150	+950	-350
160	180	+1 150	-150	+1 100	-200	-	-	+1 100	-200	+1 150	-150	-	-
180	190	+1 150	-150	+1 100	-200	-	-	+1 100	-200	+1 200	-100	-	-
190	200	+1 150	-150	+1 100	-200	-	-	+1 100	-200	+1 200	-100	-	-
200	225	+1 200	-100	+1 150	-150	-	-	+1 150	-150	+1 250	-50	-	-
225	250	+1 200	-100	+1 200	-100	-	-	+1 200	-100	+1 300	0	-	-
250	280	+1 300	0	+1 250	-50	-	-	+1 250	-50	-	-	-	-
280	300	+1 400	+100	+1 300	0	-	-	+1 300	0	-	-	-	-
300	315	+1 400	+100	+1 350	+50	-	-	+1 350	+50	-	-	-	-
315	340	+1 500	-200	+1 450	-250	-	-	+1 450	+200	-	-	-	-

Axial internal clearance

The bearing sets of standard metric bearings are produced with the axial internal clearance provided in **table 2** as standard. The values in the table apply to bearing pairs before they are mounted under measuring loads of

- 0,1 kN for bearings with outside diameter $D \leq 90$ mm
- 0,3 kN for bearings with outside diameter $90 < D \leq 240$ mm
- 0,5 kN for bearings with outside diameter $D > 240$ mm.

Matched bearing sets having a clearance other than the standard value are identified by the designation suffix C followed by a two or three-figure number which gives the mean axial internal clearance in μm . The range of the special clearance is, however, the same as for the standard clearance, i.e. for the bearing set 32232 J2/DFC230, which has a mean axial internal clearance of 230 μm , the clearance will lie in the range 200 to 260 μm .

Table 2

Axial internal clearance of matched single row metric taper roller bearings

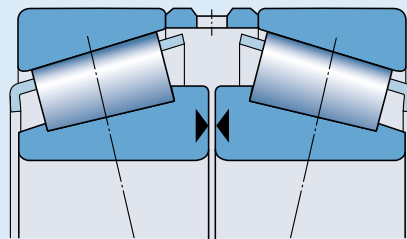

Bore diameter d	Axial internal clearance of matched bearings of series											
	329		320 X		330		331, 302, 322, 332		303, 323		313 (X)	
over incl.	min	max	min	max	min	max	min	max	min	max	min	max
mm	μm											
– 30	–	–	80	120	–	–	100	140	130	170	60	100
30 40	–	–	100	140	–	–	120	160	140	180	70	110
40 50	–	–	120	160	180	220	140	180	160	200	80	120
50 65	–	–	140	180	200	240	160	200	180	220	100	140
65 80	–	–	160	200	250	290	180	220	200	260	110	170
80 100	270	310	190	230	350	390	210	270	240	300	110	170
100 120	270	330	220	280	340	400	220	280	280	340	130	190
120 140	310	370	240	300	340	400	240	300	330	390	160	220
140 160	370	430	270	330	340	400	270	330	370	430	180	240
160 180	370	430	310	370	–	–	310	370	390	450	–	–
180 190	370	430	340	400	–	–	340	400	440	500	–	–
190 200	390	450	340	400	–	–	340	400	440	500	–	–
200 225	440	500	390	450	–	–	390	450	490	550	–	–
225 250	440	500	440	500	–	–	440	500	540	600	–	–
250 280	540	600	490	550	–	–	490	550	–	–	–	–
280 300	640	700	540	600	–	–	540	600	–	–	–	–
300 340	640	700	590	650	–	–	590	650	–	–	–	–

Paired single row taper roller bearings

Misalignment

Any misalignment of the outer rings relative to the inner rings of matched bearing pairs can only be accommodated between the rollers and raceways by force. The increased stress in the bearing caused by misalignment should be avoided. If misalignment cannot be avoided, SKF recommends using the less rigid face-to-face arrangement.

Cages

SKF single row taper roller bearings that are matched in bearing sets, are fitted as standard with a pressed window-type steel cage, roller centred (→ fig. 3).

Minimum load

In order to provide satisfactory operation, paired taper roller bearings, like all ball and roller bearings, must always be subjected to a given minimum load, particularly if they are to operate at high speeds or are to be subjected to high accelerations or rapid changes in the direction of load. Under such conditions, the inertia forces of the rollers and cages, and the friction in the lubricant, can have a detrimental influence on the rolling conditions in the bearing arrangement and may cause damaging sliding movements to occur between the rollers and raceways.

The requisite minimum radial load to be applied to matched pairs of SKF standard bearings can be estimated from

$$F_{rm} = 0,02 C$$

and for matched pairs of SKF Explorer bearings from

$$F_{rm} = 0,017 C$$

where

F_{rm} = minimum radial load for a bearing pair, kN
 C = basic dynamic load rating of a bearing pair, kN (→ product tables)

When starting up at low temperatures or when the lubricant is highly viscous, even greater minimum loads may be required. The weight of the components supported by the bearing pair, together with external forces, generally exceeds

Fig. 3

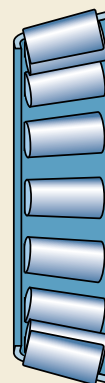

the requisite minimum load. If this is not the case, the bearing pair must be subjected to an additional radial load.

Equivalent dynamic bearing load

For bearing pairs arranged face-to-face or back-to-back

$$P = F_r + Y_1 F_a \quad \text{when } F_a/F_r \leq e$$
$$P = 0,67 F_r + Y_2 F_a \quad \text{when } F_a/F_r > e$$

and for bearing pairs arranged in tandem

$$P = F_r \quad \text{when } F_a/F_r \leq e$$
$$P = 0,4 F_r + Y F_a \quad \text{when } F_a/F_r > e$$

F_r and F_a are the forces acting on the bearing pair. Values for the calculation factors e , Y , Y_1 and Y_2 are provided in the product tables.

When determining the axial force for bearing pairs arranged in tandem reference should be made to the section “Determining axial force for bearings mounted singly or paired in tandem” on **page 612**.

Equivalent static bearing load

For bearing pairs arranged face-to-face or back-to-back

$$P_0 = F_r + Y_0 F_a$$

and for bearing pairs arranged in tandem

$$P_0 = 0,5 F_r + Y_0 F_a$$

When $P_0 < F_r$, $P_0 = F_r$ should be used. F_r and F_a are the forces acting on the bearing pair. Values of the calculation factor Y_0 are provided in the product tables.

When determining the axial force for bearing pairs arranged in tandem reference should be made to the section “Determining axial force for bearings mounted singly or paired in tandem” on **page 612**.

Supplementary designations

The designation suffixes used to identify certain features of SKF paired single row taper roller bearings are explained in the following.

- CL7C** High-performance design for pinion bearing arrangements
- C...** Special clearance. The two or three-figure number immediately following the C gives the mean axial internal clearance in μm
- DB** Matched bearing pair arranged back-to-back. A figure combination immediately following the DB identifies the design of the intermediate rings
- DF** Matched bearing pair arranged face-to-face. A figure combination immediately following the DF identifies the design of the intermediate ring
- DT** Matched bearing pair arranged in tandem. A figure combination immediately following the DT identifies the design of the intermediate rings
- HA1** Case-hardened inner and outer rings
- HA3** Case-hardened inner ring
- J** Pressed window-type steel cage. A figure following the J indicates a different cage design
- Q** Optimized contact geometry and surface finish
- T** T, followed by a figure, identifies the total width of bearing pairs arranged back-to-back or in tandem.
- X** Boundary dimensions changed to conform to ISO

Fits for bearing pairs

The values of axial internal clearance provided in **table 2** on **page 675** are so dimensioned that if the bearings are mounted on shafts machined to

- m5 for shaft diameters up to and including 140 mm
- n6 for shaft diameters over 140 mm and up to and including 200 mm
- p6 for shaft diameters above 200 mm

an appropriate operational clearance will be obtained. These shaft seating tolerances are recommended where loads are moderate to heavy and rotating loads apply for the inner ring. If tighter fits are selected, it is necessary to check that the bearings do not become pinched or clamped.

For stationary outer ring load, the recommended housing bore tolerance is J6 or H7.

Determining the load acting on bearing pairs

If matched pairs of taper roller bearings arranged face-to-face or back-to-back are mounted together with a third bearing, the bearing arrangement is statically indeterminate. In these cases the size of the radial load F_r acting on the bearing pair must first be determined.

Bearing pairs arranged face-to-face

For bearing pairs where the two bearings are arranged face-to-face (→ **fig. 4**) it can be assumed that the radial load will act at the geometric centre of the bearing set, as the distance between the pressure centres of the two bearings is short compared with the distance between the geometric centres of the set and the other bearing. In this case it can be assumed that the bearing arrangement is statically determined.

Bearing pairs arranged back-to-back

The distance between the pressure centres of two bearings arranged back-to-back in a matched set is large compared with the distance L between the geometric centres of the set and the other bearing (→ **fig. 5**). It is therefore necessary to determine the magnitude of the load acting on the bearing pair and also the distance a_1 at which the load acts. The magnitude of the radial load can be obtained from the equation

$$F_r = \frac{L_1}{L - a_1} K_r$$

where

F_r = radial load acting on a bearing pair, kN

K_r = radial force acting on the shaft, kN

L = distance between the geometric centres of the two bearing positions, mm

L_1 = distance between the centre of bearing position I and the point of action of the force K_r , mm

a = distance between the bearing pressure centres, mm

a_1 = distance between the geometric centre of the bearing set and the point of action of the radial load F_r , mm

Fig. 4

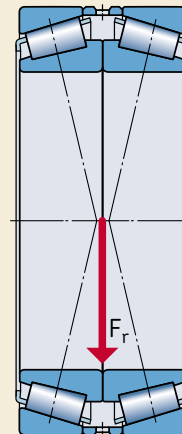

The distance a_1 can be determined using **diagram 1**. The distance of the pressure centres a and the calculation factor Y_2 are provided in the product table.

Fig. 5

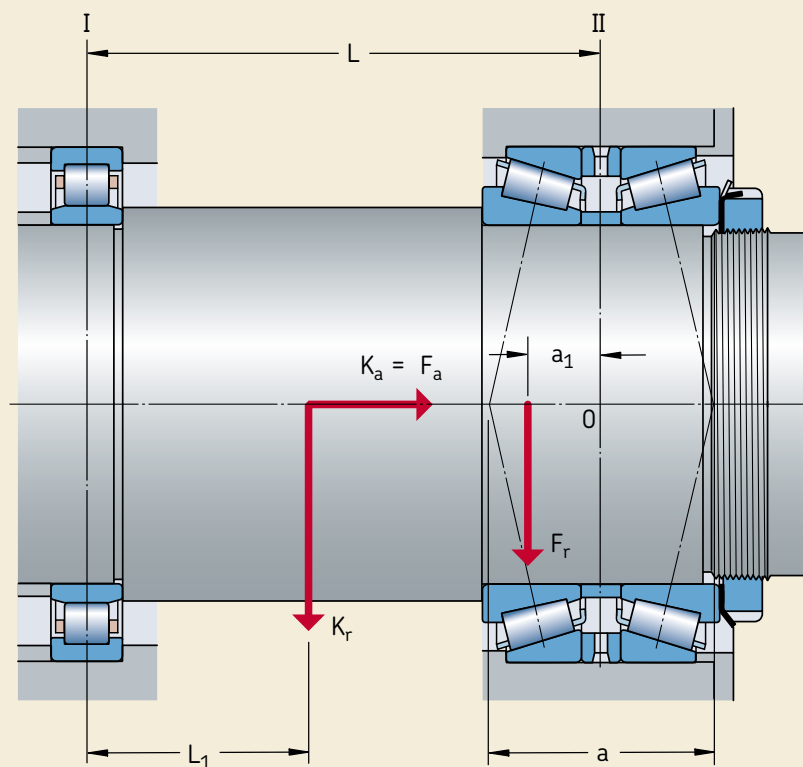
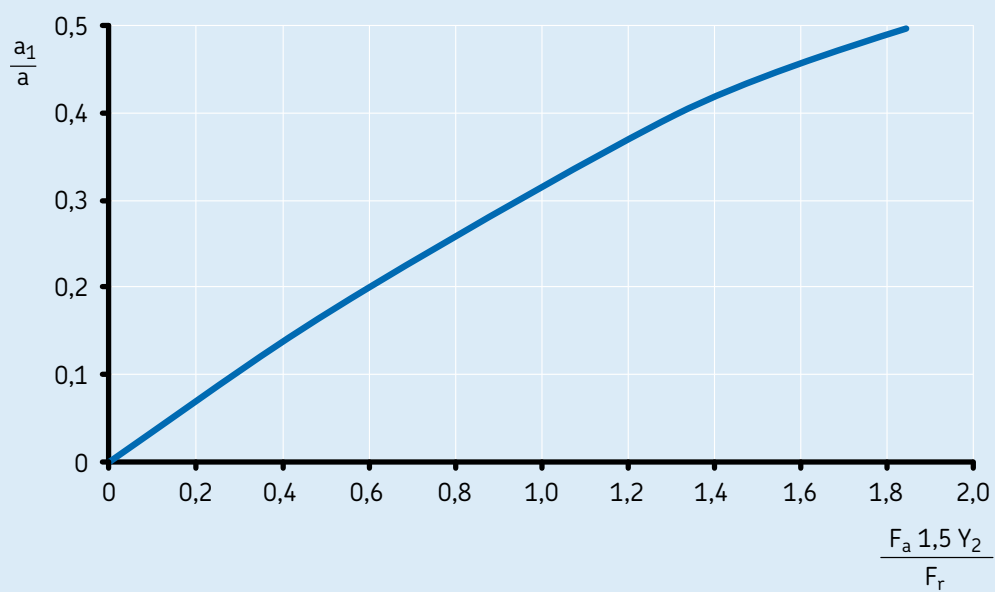
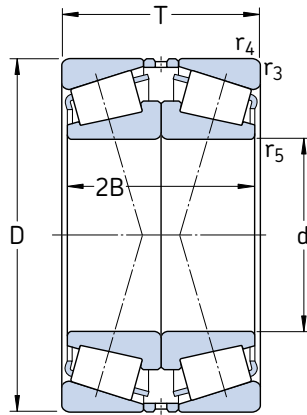

Diagram 1



Single row taper roller bearings
paired face-to-face
d 25 – 80 mm



Principal dimensions			Basic load ratings		Fatigue load limit P_u	Speed ratings		Mass	Designation
d	D	T	dynamic C	static C_0		Refer- ence speed	Limiting speed		
mm			kN		kN	r/min		kg	–
25	62	36,5	64,4	80	8,65	6 000	11 000	0,55	31305 J2/QDF
30	72	41,5	80,9	100	11,4	5 300	9 500	0,85	31306 J2/QDF
35	80	45,5	105	134	15,6	4 500	8 500	1,10	31307 J2/QDF
40	90	50,5	146	163	19	4 500	7 500	1,50	* 31308 J2/QCL7CDF
45	100	54,5	180	204	24,5	4 000	6 700	2,00	* 31309 J2/QCL7CDF
50	90	43,5	130	183	20,8	4 500	7 500	1,10	30210 J2/QDF
	110	58,5	208	240	28,5	3 600	6 000	2,60	* 31310 J2/QCL7CDF
55	90	54	180	270	30,5	4 500	7 000	1,35	* 33011/QDF03C170
	120	63	209	275	33,5	3 000	5 600	3,30	31311 J2/QDF
60	95	46	163	245	27	4 300	6 700	1,90	* 32012 X/QCL7CDFC250
	110	59,5	216	320	37,5	3 600	6 000	2,40	32212 J2/QDFC290
	130	67	246	335	40,5	2 800	5 300	4,10	31312 J2/QDF
65	120	49,5	228	270	32,5	3 600	5 600	1,20	* 30213 J2/QDF
	140	72	281	380	47,5	2 600	4 800	5,05	31313 J2/QCL7CDF
70	110	50	172	305	34,5	3 400	5 600	1,80	32014 X/QDF
	110	62	220	400	45,5	3 400	5 600	2,40	33014/DF
	150	76	319	440	54	2 400	4 500	6,15	31314 J2/QCL7CDF
75	115	62	233	455	52	3 200	5 300	2,40	33015/QDF
	125	74	303	530	63	3 000	5 000	3,80	33115/QDFC150
	130	54,5	238	355	41,5	3 000	5 000	2,85	30215 J2/QDF
	130	66,5	275	425	49	3 000	5 000	3,40	32215 J2/QDF
	160	80	358	490	58,5	2 200	4 300	7,25	31315 J2/QCL7CDF
80	125	58	233	430	49	3 000	5 000	2,65	32016 X/QDFC165
	140	70,5	319	490	57	2 800	4 500	4,25	32216 J2/QDF
	170	85	380	530	64	2 200	4 000	8,75	31316 J1/QCL7CDF

* SKF Explorer bearing

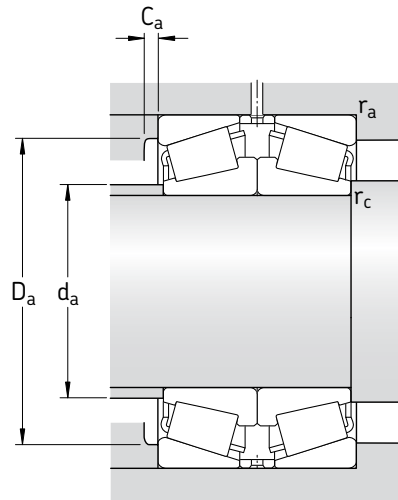

Dimensions				Abutment and fillet dimensions						Calculation factors			
d	2B	r _{3,4} min	r ₅ min	d _a max	D _a min	D _a max	C _a min	r _a max	r _c max	e	Y ₁	Y ₂	Y ₀
mm				mm						-			
25	34	1,5	0,6	34	47	55	3	1,5	0,6	0,83	0,81	1,2	0,8
30	38	1,5	0,6	40	55	65	3	1,5	0,6	0,83	0,81	1,2	0,8
35	42	1,5	0,6	45	62	71	3	1,5	0,6	0,83	0,81	1,2	0,8
40	46	1,5	0,6	51	71	81	3	1,5	0,6	0,83	0,81	1,2	0,8
45	50	1,5	0,6	57	79	91	4	1,5	0,6	0,83	0,81	1,2	0,8
50	40	1,5	0,6	58	79	83	3	1,5	0,6	0,43	1,6	2,3	1,6
	54	2	0,6	62	87	100	4	2	0,6	0,83	0,81	1,2	0,8
55	54	1,5	0,6	63	81	83	5	1,5	0,6	0,31	2,2	3,3	2,2
	58	2	0,6	68	94	112	4	2	0,6	0,83	0,81	1,2	0,8
60	46	1,5	0,6	67	85	88	4	1,5	0,6	0,43	1,6	2,3	1,6
	56	1,5	0,6	69	95	103	4	1,5	0,6	0,4	1,7	2,5	1,6
	62	2,5	1	74	103	118	5	2	1	0,83	0,81	1,2	0,8
65	46	1,5	0,6	78	106	113	4	1,5	0,6	0,4	1,7	2,5	1,6
	66	2,5	1	80	111	128	5	2	1	0,83	0,81	1,2	0,8
70	50	1,5	0,6	78	98	103	5	1,5	0,6	0,43	1,6	2,3	1,6
	62	1,5	0,6	78	99	103	5	1,5	0,6	0,28	2,4	3,6	2,5
	70	2,5	1	85	118	138	5	2	1	0,83	0,81	1,2	0,8
75	62	1,5	0,6	84	104	108	6	1,5	0,6	0,3	2,3	3,4	2,2
	74	1,5	0,6	84	109	117	6	1,5	0,6	0,4	1,7	2,5	1,6
	50	1,5	0,6	86	115	122	4	1,5	0,6	0,43	1,6	2,3	1,6
	62	1,5	0,6	85	114	122	4	1,5	0,6	0,43	1,6	2,3	1,6
	74	2,5	1	91	127	148	6	2	1	0,83	0,81	1,2	0,8
80	58	1,5	0,6	90	112	117	6	1,5	0,6	0,43	1,6	2,3	1,6
	66	2	0,6	91	122	130	5	2	0,6	0,43	1,6	2,3	1,6
	78	2,5	1	97	134	158	6	2	1	0,83	0,81	1,2	0,8

Single row taper roller bearings
paired face-to-face
d 85 – 120 mm

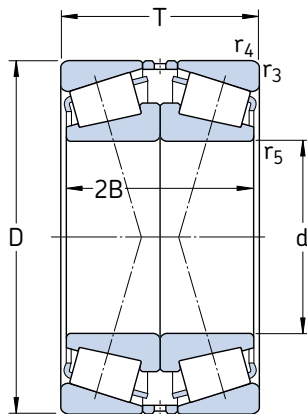

Principal dimensions			Basic load ratings		Fatigue load limit P_u	Speed ratings		Mass	Designation
d	D	T	dynamic	static		Refer- ence speed	Limiting speed		
mm			kN		kN	r/min		kg	–
85	130	58	238	450	51	2 800	4 800	2,80	32017 X/QDF
	130	72	308	620	69,5	2 800	4 800	3,55	33017/QDFC240
	150	61	303	440	51	2 600	4 300	4,30	30217 J2/QDF
	150	77	369	570	65,5	2 600	4 300	5,45	32217 J2/QDF
	150	98	495	850	96,5	2 400	4 300	7,35	33217/QDF
90	140	64	292	540	62	2 600	4 300	3,65	32018 X/QDF
	140	78	369	710	78	2 600	4 500	4,50	33018/QDFC150
	160	65	336	490	57	2 400	4 000	5,15	30218 J2/DF
	160	85	429	680	76,5	2 400	4 000	6,90	32218 J2/QDF
	190	93	457	630	73,5	1 900	3 400	11,5	31318 J2/DF
95	145	78	380	735	81,5	2 600	4 300	5,00	33019/QDF
	170	91	484	780	86,5	2 200	3 800	8,45	32219 J2/DF
	200	99	501	710	78	1 800	3 400	13,0	31319 J2/DF
100	150	64	292	560	62	2 400	4 000	3,95	32020 X/QDF
	180	74	418	640	72	2 200	3 600	7,60	30220 J2/DF
	180	98	539	880	96,5	2 200	3 600	10,0	32220 J2/DF
105	215	103	693	980	106	1 900	3 200	16,5	30320 J2/DFC400
	215	113	644	930	102	1 700	3 000	18,0	31320 XJ2/DF
105	160	70	347	670	73,5	2 200	3 800	5,00	32021 X/QDF
110	170	76	402	780	85	2 200	3 600	6,30	32022 X/QDF
	180	112	627	1 250	134	2 000	3 400	11,5	33122/DF
	200	82	523	800	90	2 000	3 200	10,5	30222 J2/DF
110	200	112	682	1 140	122	1 900	3 200	14,5	32222 J2/DF
	240	126	781	1 160	125	1 500	2 800	26,0	31322 XJ2/DF
120	180	76	418	830	88	2 000	3 400	6,75	32024 X/DF
	180	96	495	1 080	112	2 000	3 400	8,65	33024/DFC250
	215	87	583	915	98	1 800	3 000	13,0	30224 J2/DF
	215	123	792	1 400	146	1 800	3 000	18,5	32224 J2/DF
120	260	119	968	1 400	146	1 600	2 600	29,5	30324 J2/DFC600
	260	136	935	1 400	146	1 400	2 400	33,5	31324 XJ2/DF

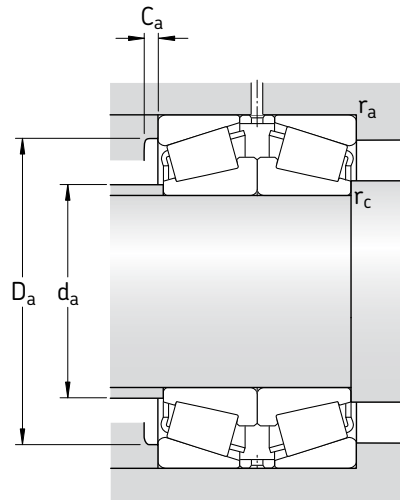

Dimensions				Abutment and fillet dimensions						Calculation factors			
d	2B	r _{3,4} min	r ₅ min	d _a max	D _a min	D _a max	C _a min	r _a max	r _c max	e	Y ₁	Y ₂	Y ₀
mm				mm						-			
85	58	1,5	0,6	94	117	122	6	1,5	0,6	0,44	1,5	2,3	1,6
	72	1,5	0,6	94	118	122	6	1,5	0,6	0,3	2,3	3,4	2,2
	56	2	0,6	97	132	140	5	2	0,6	0,43	1,6	2,3	1,6
	72	2	0,6	97	130	140	5	2	0,6	0,43	1,6	2,3	1,6
	98	2	0,6	96	128	140	7	2	0,6	0,43	1,6	2,3	1,6
	82	3	1	103	143	166	6	2,5	1	0,83	0,81	1,2	0,8
90	64	1,5	0,6	100	125	132	6	1,5	0,6	0,43	1,6	2,3	1,6
	78	1,5	0,6	100	127	132	7	1,5	0,6	0,27	2,5	3,7	2,5
	60	2	0,6	102	140	150	5	2	0,6	0,43	1,6	2,3	1,6
	80	2	0,6	102	138	150	5	2	0,6	0,43	1,6	2,3	1,6
	86	3	1	109	151	176	5	2,5	1	0,83	0,81	1,2	0,8
95	78	1,5	0,6	104	131	138	7	1,5	0,6	0,28	2,4	3,6	2,5
	86	2,5	1	109	145	158	5	2	1	0,43	1,6	2,3	1,6
	90	3	1	114	157	186	5	2,5	1	0,83	0,81	1,2	0,8
100	64	1,5	0,6	110	134	142	6	1,5	0,6	0,46	1,5	2,2	1,4
	68	2,5	1	116	157	168	5	2	1	0,43	1,6	2,3	1,6
	92	2,5	1	115	154	168	5	2	1	0,43	1,6	2,3	1,6
	94	3	1	127	184	201	6	2,5	1	0,35	1,9	2,9	1,8
	102	3	1	121	168	201	7	2,5	1	0,83	0,81	1,2	0,8
105	70	2	0,6	116	143	150	6	2	0,6	0,44	1,5	2,3	1,6
110	76	2	0,6	123	152	160	7	2	0,6	0,43	1,6	2,3	1,6
	112	2	0,6	121	155	170	9	2	0,6	0,43	1,6	2,3	1,6
	76	2,5	1	129	174	188	6	2	1	0,43	1,6	2,3	1,6
	106	2,5	1	127	170	188	6	2	1	0,43	1,6	2,3	1,6
	114	3	1	135	188	226	7	2,5	1	0,83	0,81	1,2	0,8
120	76	2	0,6	132	161	170	7	2	0,6	0,46	1,5	2,2	1,4
	96	2	0,6	132	160	170	6	2	0,6	0,3	2,3	3,4	2,2
	80	2,5	1	141	187	203	6	2	1	0,43	1,6	2,3	1,6
	116	2,5	1	137	181	203	7	2	1	0,43	1,6	2,3	1,6
	110	3	1	153	221	245	7	2,5	1	0,35	1,9	2,9	1,8
	124	3	1	145	203	245	9	2,5	1	0,83	0,81	1,2	0,8

Single row taper roller bearings
paired face-to-face
d 130 – 220 mm

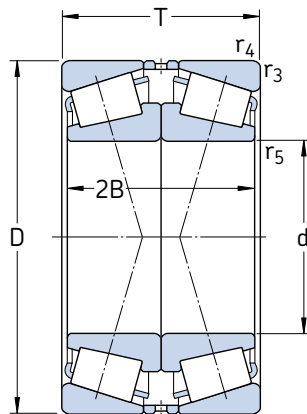

Principal dimensions			Basic load ratings		Fatigue load limit P_u	Speed ratings		Mass	Designation
d	D	T	dynamic C	static C_0		Refer- ence speed	Limiting speed		
mm			kN		kN	r/min		kg	–
130	180	64	341	735	76,5	2 000	3 600	4,95	32926/DF
	200	90	539	1 080	110	1 800	3 000	10,0	32026 X/DF
140	230	87,5	627	980	106	1 700	2 800	14,5	30226 J2/DF
	230	135,5	952	1 660	170	1 600	2 800	23,0	32226 J2/DF
	280	144	1 050	1 560	163	1 300	2 400	40,0	31326 XJ2/DF
	250	143,5	1 100	2 000	200	1 500	2 600	29,5	32228 J2/DF
150	210	90	561	1 160	116	1 700	2 800	11,0	32028 X/DF
	250	91,5	721	1 140	116	1 500	2 600	18,0	30228 J2/DFC100
	250	143,5	1 100	2 000	200	1 500	2 600	29,5	32228 J2/DF
	300	154	1 190	1 800	176	1 200	2 200	52,5	31328 XJ2/DF
160	225	96	644	1 320	132	1 600	2 600	13,5	32030 X/DF
	270	98	737	1 120	114	1 400	2 400	22,5	30230/DFC350
	270	154	1 250	2 280	224	1 400	2 400	37,0	32230 J2/DF
	320	164	1 340	2 040	200	1 100	2 000	58,5	31330 XJ2/DF
170	240	102	737	1 560	156	1 500	2 400	16,0	32032 X/DF
	290	104	913	1 460	143	1 300	2 200	27,5	30232 J2/DF
	290	168	1 510	2 800	265	1 300	2 200	48,0	32232 J2/DF
180	230	76	484	1 160	110	1 500	2 800	9,20	32934/DFC225
	260	114	880	1 830	180	1 400	2 200	22,0	32034 X/DF
	310	182	1 720	3 250	300	1 200	2 000	59,0	32234 J2/DF
190	250	90	605	1 460	137	1 400	2 600	14,0	32936/DF
	280	128	1 100	2 320	220	1 300	2 000	29,5	32036 X/DF
	320	114	1 010	1 630	160	1 200	2 000	42,0	30236 J2/DFC300
	320	182	1 720	3 250	300	1 100	1 900	61,0	32236 J2/DF
200	260	90	616	1 530	143	1 300	2 400	14,5	32938/DF
	290	128	1 120	2 400	224	1 200	2 000	30,5	32038 X/DF
	340	120	1 230	2 000	190	1 100	1 800	50,0	30238 J2/DFC700
220	310	140	1 280	2 750	255	1 100	1 900	39,0	32040 X/DF
	360	128	1 340	2 240	212	1 000	1 700	52,0	30240 J2/DFC570
	360	208	2 090	4 000	360	1 000	1 700	88,0	32240 J2/DF
220	300	102	842	2 000	183	1 100	2 000	21,0	32944/DFC300
	340	152	1 540	3 350	300	1 000	1 700	51,0	32044 X/DF

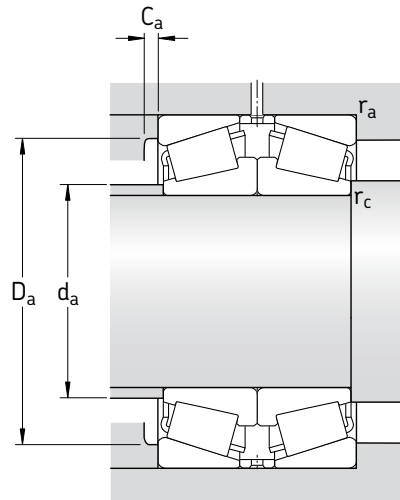

Dimensions				Abutment and fillet dimensions						Calculation factors			
d	2B	r _{3,4} min	r ₅ min	d _a max	D _a min	D _a max	C _a min	r _a max	r _c max	e	Y ₁	Y ₂	Y ₀
mm				mm						-			
130	64	1,5	0,6	141	167	172	6	1,5	0,6	0,33	2	3	2
	90	2	0,6	144	178	190	7	2	0,6	0,43	1,6	2,3	1,6
	80	3	1	152	203	216	7	2,5	1	0,43	1,6	2,3	1,6
	128	3	1	146	193	216	7	2,5	1	0,43	1,6	2,3	1,6
140	132	4	1,5	157	218	263	8	3	1,5	0,83	0,81	1,2	0,8
	90	2	0,6	153	187	200	7	2	0,6	0,46	1,5	2,2	1,4
	84	3	1	164	219	236	7	2,5	1	0,43	1,6	2,3	1,6
	136	3	1	159	210	236	8	2,5	1	0,43	1,6	2,3	1,6
140	140	4	1,5	169	235	283	9	3	1,5	0,83	0,81	1,2	0,8
	96	2,5	1	164	200	213	8	2	1	0,46	1,5	2,2	1,4
	90	3	1	175	234	256	9	2,5	1	0,43	1,6	2,3	1,6
	146	3	1	171	226	256	8	2,5	1	0,43	1,6	2,3	1,6
150	150	4	1,5	181	251	303	9	3	1,5	0,83	0,81	1,2	0,8
	102	2,5	1	175	213	228	8	2	1	0,46	1,5	2,2	1,4
	96	3	1	189	252	275	8	2,5	1	0,43	1,6	2,3	1,6
	160	3	1	183	242	275	10	2,5	1	0,43	1,6	2,3	1,6
160	102	2,5	1	175	213	228	8	2	1	0,46	1,5	2,2	1,4
	96	3	1	189	252	275	8	2,5	1	0,43	1,6	2,3	1,6
	160	3	1	183	242	275	10	2,5	1	0,43	1,6	2,3	1,6
	76	2	0,6	183	213	220	7	2	0,6	0,37	1,7	2,8	1,8
170	114	2,5	1	188	230	246	10	2	1	0,44	1,5	2,3	1,6
	172	4	1,5	196	259	293	10	3	1,5	0,43	1,6	2,3	1,6
	90	2	0,6	194	225	240	8	2	0,6	0,48	1,4	2,1	1,4
	128	2,5	1	199	247	266	10	2	1	0,43	1,6	2,3	1,6
180	104	4	1,5	211	278	303	9	3	1,5	0,44	1,5	2,3	1,6
	172	4	1,5	204	267	303	10	3	1,5	0,44	1,5	2,3	1,6
	90	2	0,6	204	235	248	8	2	0,6	0,48	1,4	2,1	1,4
	128	2,5	1	210	257	276	10	2	1	0,44	1,5	2,3	1,6
190	110	4	1,5	224	298	323	9	3	1,5	0,43	1,6	2,3	1,6
	90	2	0,6	204	235	248	8	2	0,6	0,48	1,4	2,1	1,4
	128	2,5	1	210	257	276	10	2	1	0,44	1,5	2,3	1,6
	110	4	1,5	224	298	323	9	3	1,5	0,43	1,6	2,3	1,6
200	140	2,5	1	222	273	296	11	2	1	0,43	1,6	2,3	1,6
	116	4	1,5	237	315	343	9	3	1,5	0,43	1,6	2,3	1,6
	196	4	1,5	231	302	343	11	3	1,5	0,4	1,7	2,5	1,6
	90	2	0,6	204	235	248	8	2	0,6	0,48	1,4	2,1	1,4
220	128	2,5	1	210	257	276	10	2	1	0,44	1,5	2,3	1,6
	110	4	1,5	224	298	323	9	3	1,5	0,43	1,6	2,3	1,6
	102	2,5	1	234	275	286	9	2	1	0,43	1,6	2,3	1,6
	152	3	1	244	300	325	12	2,5	1	0,43	1,6	2,3	1,6

Single row taper roller bearings
 paired face-to-face
 d 240 – 320 mm

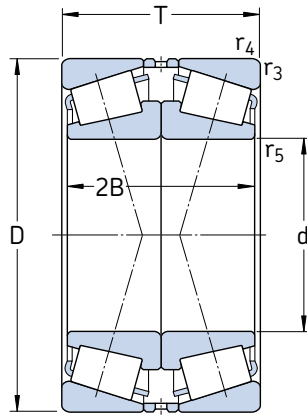

Principal dimensions			Basic load ratings		Fatigue load limit P_u	Speed ratings		Mass	Designation
d	D	T	dynamic C	static C_0		Refer- ence speed	Limiting speed		
mm			kN		kN	r/min		kg	–
240	360	152	1 570	3 550	315	950	1 600	54,5	32048 X/DF
260	400	174	1 980	4 400	380	850	1 400	79,5	32052 X/DF
280	420	174	2 050	4 750	400	800	1 300	84,5	32056 X/DF
300	420	152	1 790	4 500	375	800	1 400	65,5	32960/DF
320	480	200	2 640	6 200	510	700	1 100	125	32064 X/DF

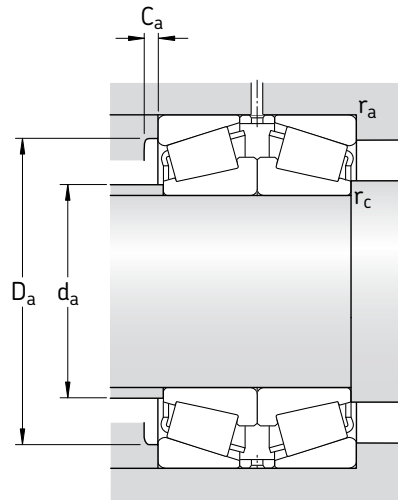

Dimensions				Abutment and fillet dimensions						Calculation factors			
d	2B	$r_{3,4}$ min	r_5 min	d_a max	D_a min	D_a max	C_a min	r_a max	r_c max	e	Y_1	Y_2	Y_0
mm				mm						-			
240	152	3	1	262	318	345	12	2,5	1	0,46	1,5	2,2	1,4
260	174	4	1,5	287	352	383	13	3	1,5	0,43	1,6	2,3	1,6
280	174	4	1,5	305	370	400	14	3	1,5	0,46	1,5	2,2	1,4
300	152	3	1	324	383	404	12	2,5	1	0,4	1,7	2,5	1,6
320	200	4	1,5	350	424	460	15	3	1,5	0,46	1,5	2,2	1,4

**Single row taper roller bearings
paired back-to-back**
d **40 – 170** mm

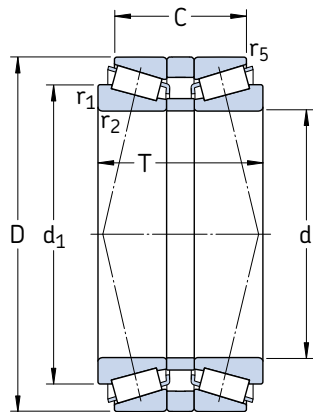

Principal dimensions			Basic load ratings		Fatigue load limit P_u	Speed ratings		Mass	Designation
d	D	T	dynamic	static		Refer- ence speed	Limiting speed		
mm			kN		kN	r/min		kg	–
40	90	72	147	190	21,6	4 800	8 000	1,90	30308T72 J2/QDBC220
75	130	70	238	355	41,5	3 000	5 000	3,25	30215T70 J2/DBC270
	130	80	275	425	49	3 000	5 000	6,80	32215T80 J2/QDB
80	140	78	319	490	57	2 800	4 500	4,45	32216T78 J2/QDBC110
85	130	66	238	450	51	2 800	4 800	2,70	32017T66 X/QDB/C280
	130	70	308	620	69,5	2 800	4 800	3,50	33017T70/QDB
	150	71	303	440	51	2 600	4 300	4,10	30217T71 J2/QDB
90	190	103	457	630	73,5	1 900	3 400	12,5	31318T103 J2/DB31
100	180	108	539	880	96,5	2 200	3 600	10,5	32220T108 J2/DB
	180	140	539	880	96,5	2 200	3 600	12,5	32220T140 J2/DB11
110	170	84	402	780	85	2 200	3 600	6,50	32022T84 X/QDBC200
120	180	84	418	830	88	2 000	3 400	7,00	32024T84 X/QDBC200
	215	146	792	1 400	146	1 800	3 000	21,0	32224T146 J2/DB31C210
	260	146	935	1 400	146	1 400	2 400	35,0	31324T146 XJ2/DB
130	230	97,5	627	980	106	1 700	2 800	15,0	30226T97.5 J2/DB
	280	142	1 080	1 600	166	1 400	2 400	36,5	30326T142 J2/DB11C150
140	210	130	561	1 160	116	1 700	2 800	12,7	32028T130 X/QDB
	250	106	721	1 140	116	1 500	2 600	19,5	30228T106 J2/DB
	250	158	1 100	2 000	200	1 500	2 600	31,0	32228T158 J2/DB
150	270	168	1 250	2 280	224	1 400	2 400	38,0	32230T168 J2/DB
	270	248	1 250	2 280	224	1 400	2 400	39,5	32230T248 J2/DB31
	320	179	1 340	2 040	200	1 100	2 000	58,5	31330T179 XJ2/DB
160	290	179	1 510	2 800	265	1 300	2 200	52,5	32232T179 J2/DB32C230
170	260	162	880	1 830	180	1 400	2 200	30,5	32034T162 X/DB31

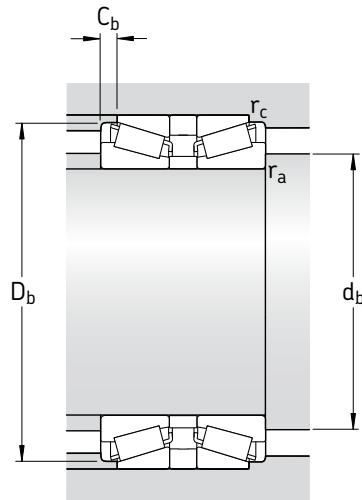

Dimensions			Abutment and fillet dimensions					Calculation factors						
d	d ₁ ~	C	r _{1,2} min	r ₅ min	a	d _b min	D _b min	C _b min	r _a max	r _c max	e	Y ₁	Y ₂	Y ₀
mm						mm					-			
40	62,5	61,5	2	0,6	50	49	82	5	2	0,6	0,35	1,9	2,9	1,8
75	99,2	59,5	2	0,6	69	84	124	5	2	0,6	0,43	1,6	2,3	1,6
	100	67,5	2	0,6	72	84	125	6	2	0,6	0,43	1,6	2,3	1,6
80	106	63,5	2,5	0,6	68	90	134	7	2	0,6	0,43	1,6	2,3	1,6
85	108	52	1,5	0,6	64	92	125	7	1,5	0,6	0,44	1,5	2,3	1,4
	108	56	1,5	0,6	68	92	125	7	1,5	0,6	0,44	1,5	2,3	1,4
	112	58,5	2,5	0,6	71	95	141	6,5	2	0,6	0,43	1,6	2,3	1,6
90	138	70	4	1	124	105	179	16,5	3	1	0,83	0,81	1,2	0,8
100	135	88	3	1	92	112	171	10	2,5	1	0,43	1,6	2,3	1,6
	135	120	3	1	124	112	171	10	2,5	1	0,43	1,6	2,3	1,6
110	140	66	2,5	0,6	80	121	163	9	2	0,6	0,43	1,6	2,3	1,6
120	150	66	2,5	0,6	86	131	173	9	2	0,6	0,46	1,5	2,2	1,4
	163	123	3	1	125	132	204	11,5	2,5	1	0,43	1,6	2,3	1,6
	190	134	4	1	166	135	244	26	3	1	0,83	0,81	1,2	0,9
130	173	78	4	1	99	146	217	9,5	3	1	0,43	1,6	2,3	1,6
	196	112,5	5	1,5	117	150	255	14,5	4	1,5	0,35	1,9	2,9	1,8
140	175	108	2,5	0,6	132	152	202	11	2	0,6	0,46	1,5	2,2	1,4
	186	86,5	4	1	108	156	234	9,5	3	1	0,43	1,6	2,3	1,6
	191	130,5	4	1	134	156	238	13,5	3	1	0,43	1,6	2,3	1,6
150	205	134	4	1	142	166	254	17	3	1	0,43	1,6	2,3	1,6
	205	214	4	1	222	166	254	17	3	1	0,43	1,6	2,3	1,6
	234	115	5	1,5	207	170	300	32	4	1,5	0,83	0,81	1,2	0,8
160	221	145	4	1	150	176	274	17	3	1	0,43	1,6	2,3	1,6
170	214	134	3	1	160	184	249	14	2,5	1	0,44	1,5	2,3	1,6

Single row taper roller bearings
paired back-to-back
d 180 – 260 mm

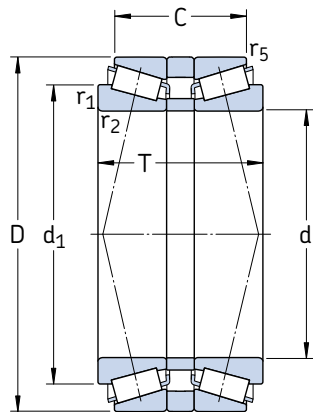

Principal dimensions			Basic load ratings		Fatigue load limit P_u	Speed ratings		Mass	Designation
d	D	T	dynamic	static		Refer- ence speed	Limiting speed		
mm			kN		kN	r/min	kg	–	
180	250	135	605	1 460	137	1 400	2 600	14,5	32936T135/DBC260
	280	150	1 100	2 320	220	1 300	2 200	29,5	32036T150 X/DB
	280	150	1 100	2 320	220	1 300	2 200	29,5	32036T150 XDB11C150
	320	196	1 720	3 250	300	1 100	1 900	61,5	32236T196 J2/DB32
190	260	102	616	1 530	143	1 300	2 400	15,0	32938T102/DB31
	260	122	616	1 530	143	1 300	2 400	15,5	32938T122/DBCG
	290	146	1 120	2 400	224	1 200	2 000	31,5	32038T146 X/DB42C220
	290	146	1 120	2 400	224	1 200	2 000	31,5	32038T146 X/DBC220
	290	183	1 120	2 400	224	1 200	2 000	32,5	32038T183 X/DB31C330
200	310	154,5	1 280	2 750	255	1 100	1 900	39,5	32040T154.5 X/DB11C170
220	340	165	1 540	3 550	300	1 000	1 700	52,0	32044T165 X/DB11C170
	340	165	1 540	3 550	300	1 000	1 700	52,0	32044T165 X/DB42C220
	340	165	1 540	3 550	300	1 000	1 700	52,0	32044T165 X/DBC340
	340	168	1 540	3 550	300	1 000	1 700	52,0	32044T168 X/DB
240	360	172	1 570	3 550	315	950	1 600	56,0	32048T172 X/DB
	440	284	3 300	6 550	550	800	1 400	180	32248T284 J3/DB
260	400	189	1 980	4 400	380	850	1 400	80,5	32052T189 X/DBC280
	400	194	1 980	4 400	380	850	1 400	80,5	32052T194 X/DB

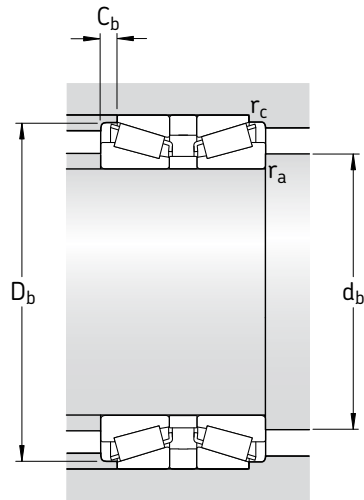

Dimensions						Abutment and fillet dimensions					Calculation factors			
d	d ₁ ~	C	r _{1,2} min	r ₅ min	a	d _b min	D _b min	C _b min	r _a max	r _c max	e	Y ₁	Y ₂	Y ₀
mm						mm					-			
180	216	83	2,5	0,6	122	192	241	11	2	0,6	0,48	1,4	2,1	1,4
	229	118	3	1	140	194	267	16	2,5	1	0,43	1,6	2,3	1,6
	229	118	3	1	140	194	267	16	2,5	1	0,43	1,6	2,3	1,6
	239	156	5	1,5	169	200	297	14	4	1,5	0,44	1,5	2,3	1,4
190	227	80	2,5	0,6	122	202	251	11	2	0,6	0,48	1,4	2,1	1,4
	227	100	2,5	0,6	142	202	251	11	2	0,6	0,48	1,4	2,1	1,4
	240	114	3	1	142	204	279	16	2,5	1	0,44	1,5	2,3	1,4
	240	114	3	1	142	204	279	16	2,5	1	0,44	1,5	2,3	1,4
	240	151	3	1	179	204	279	16	2,5	1	0,44	1,5	2,3	1,4
200	254	120,5	3	1	147	214	297	17	2,5	1	0,43	1,6	2,3	1,6
220	279	127	4	1	157	236	326	19	3	1	0,43	1,6	2,3	1,6
	279	127	4	1	157	236	326	19	3	1	0,43	1,6	2,3	1,6
	279	127	4	1	157	236	326	19	3	1	0,43	1,6	2,3	1,6
	279	130	4	1	160	236	326	19	3	1	0,43	1,6	2,3	1,6
240	299	134	4	1	175	256	346	19	3	1	0,46	1,5	2,2	1,4
	346	230	5	1,5	240	262	415	27	4	1,5	0,43	1,6	2,3	1,6
260	328	145	5	1,5	183	282	383	22	4	1,5	0,43	1,6	2,3	1,6
	328	150	5	1,5	188	282	383	22	4	1,5	0,43	1,6	2,3	1,6

**Single row taper roller bearings
paired in tandem**
d 55 – 80 mm

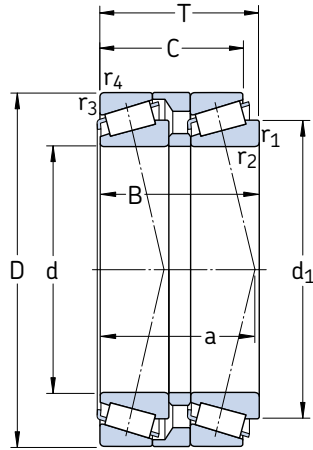

Principal dimensions			Basic load ratings		Fatigue load limit P_u	Speed ratings		Mass	Designation
d	D	T	dynamic	static C_0		Refer- ence speed	Limiting speed		
mm			kN		kN	r/min		kg	–
55	115	73	216	325	39	3 000	5 600	3,50	T7FC 055T73/QCL7CDTC10
60	125	80	264	405	49	2 800	5 300	4,05	T7FC 060T80/QCL7CDTC10
70	140	83	303	480	55	2 400	4 500	11,0	T7FC 070T83/QCL7CDTC10
80	160	98	391	630	71	2 200	4 000	16,5	T7FC 080T98/QCL7CDTC20

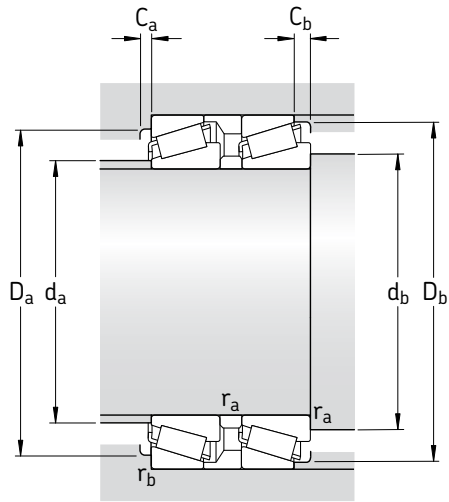

Dimensions								Abutment and fillet dimensions								Calculation factors		
d	d_1 ~	B	C	$r_{1,2}$ min	$r_{3,4}$ min	a ~	d_a max	d_b min	D_a min	D_a max	D_b min	C_a min	C_b min	r_a max	r_b max	e	Y	Y_0
mm								mm								-		
55	90	70	62,5	3	3	78	66	67	86	101	109	4	10,5	2,5	2,5	0,88	0,68	0,4
60	97	76,5	69	3	3	84	72	72	94	111	119	4	11	2,5	2,5	0,83	0,72	0,4
70	110	79,5	71	3	3	47	82	82	106	126	133	5	12	2,5	2,5	0,88	0,68	0,4
80	125	94	84	3	3	106	94	92	121	146	152	5	14	2,5	2,5	0,88	0,68	0,4



Spherical roller bearings

Standard bearings.....	696
Open bearings	696
Sealed bearings.....	698
Bearings for vibratory applications	700
SKF Explorer class bearings	701
Special bearings.....	701
Bearings on sleeves.....	702
Appropriate bearing housings	703
Bearing data – general	704
Dimensions.....	704
Tolerances.....	704
Internal clearance	704
Misalignment.....	707
Influence of operating temperature on bearing material	708
Axial load carrying capacity.....	708
Minimum load.....	708
Equivalent dynamic bearing load.....	709
Equivalent static bearing load.....	709
Supplementary designations	709
Mounting bearings with a tapered bore.....	710
Measuring the clearance reduction	710
Measuring the lock nut tightening angle.....	712
Measuring the axial drive-up	712
Measuring the inner ring expansion	714
Additional mounting information	714
Product tables	716
Spherical roller bearings	716
Sealed spherical roller bearings	740
Spherical roller bearings for vibratory applications	744
Spherical roller bearings on adapter sleeve.....	748
Spherical roller bearings on withdrawal sleeve	762



Spherical roller bearings

Spherical roller bearings have two rows of rollers with a common sphered raceway in the outer ring and two inner ring raceways inclined at an angle to the bearing axis (→ **fig. 1**). This gives them an attractive combination of design features, making them irreplaceable in many demanding applications. They are self-aligning and consequently insensitive to misalignment of the shaft relative to the housing and to shaft deflection or bending.

SKF spherical roller bearings are leading in design and can, in addition to heavy radial loads, accommodate heavy axial loads acting in both directions.

Standard bearings

The standard range of SKF spherical roller bearings comprises

- open bearings
- sealed bearings
- bearings for vibratory applications.

In addition to the standard range, SKF offers a wide range of special spherical roller bearings adapted for specific applications.

Open bearings

SKF spherical roller bearings are produced to several designs, depending on bearing series and size. The differences are

- the arrangement of the floating guide ring as well as
- the design of the inner ring and/or cages,

as described in the following (→ **fig. 2**).

C(J), CC Two pressed window-type steel cages, flangeless inner ring and guide ring centred on the inner ring (**a**).

EC(J), ECC(J) Reinforced roller complement, two pressed window-type steel cages, flangeless inner ring, guide ring centred on the inner ring (**a**).

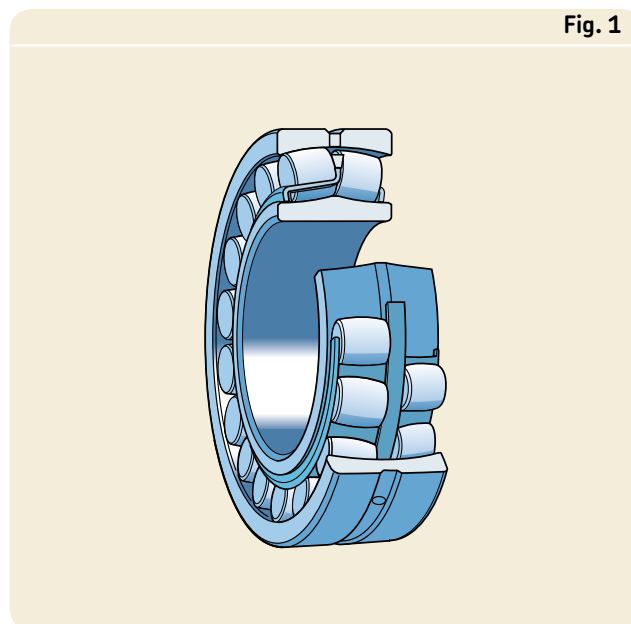

Fig. 1

CA	One-piece machined brass cage, double-pronged, retaining flanges on the inner ring and guide ring centred on the inner ring (b).
CAF	As CA, but with a steel cage.
ECA, ECAC	Reinforced roller complement, one-piece machined brass cage, double-pronged, retaining flanges on the inner ring, guide ring centred on the inner ring (b).
ECAF	As ECA, but with a steel cage.
E	For bearings with a bore diameter $d \leq 65$ mm: Two pressed window-type steel cages, flangeless inner ring and guide ring centred on the inner ring (c). For bearings with a bore diameter $d > 65$ mm: Two pressed window-type steel cages, flangeless inner ring and guide ring centred on the cages (d).
CAFA	One-piece machined steel cage, double-pronged, centred on the outer ring raceway, retaining flanges on the inner ring and guide ring centred on the inner ring (e).
CAMA	As CAFA, but with a brass cage.

With some exceptions, all SKF spherical roller bearings are produced with a cylindrical bore as well as with a tapered bore. The tapered bore of bearings in the

- 240, 241, 248 and 249 series have a taper of 1:30, designation suffix K30, and the
- other series have a taper of 1:12, designation suffix K.

Annular groove and lubrication holes

To facilitate efficient bearing lubrication, SKF spherical roller bearings are provided with

- an annular groove and three lubrication holes in the outer ring (→ **fig. 3a**), designation suffix W33, or
- three lubrication holes in the outer ring (→ **fig. 3b**), designation suffix W20.

E-design spherical roller bearings have the annular groove and three lubrication holes feature as standard so that the designation suffix W33 is omitted from the bearing designation.

Fig. 2

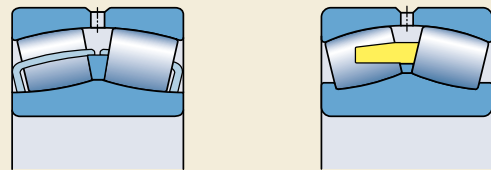

a

b

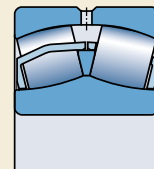

c

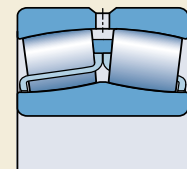

d

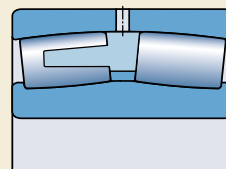

e

Fig. 3



W33

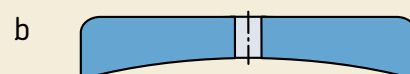

W20

Spherical roller bearings

Sealed bearings

A selection of SKF spherical roller bearings is also produced in a sealed version with contact seals on both sides (→ **fig. 4**). The seals are reinforced with sheet steel and made of an oil and wear-resistant

- acrylonitrile-butadiene rubber (NBR), designation suffix 2CS
- hydrogenated acrylonitrile-butadiene rubber (HNBR), designation suffix 2CS5
- fluoro rubber (FKM), designation suffix 2CS2.

The seals are inserted in recesses in the outer ring. For smaller bearing sizes, the seals are pressed into the recesses (**a**), while the seals for the larger sizes are held in position by means of retaining rings (**b**). The seals have two sealing lips contacting the lead-in at the sides of the inner ring raceway, to provide efficient sealing.

Sealed bearings are lubricated as standard with an extreme-pressure bearing grease according to **table 1**. They should not be heated to temperatures above 80 °C during mounting, and should not be washed.

Table 1

SKF standard grease filling for sealed spherical roller bearings

Technical specification	Grease for sealed bearings of type 2CS, 2CS2/VT143 and 2CS5/VT143
Type	Extreme pressure grease
Thickener	Lithium
Base oil type	Mineral
NLGI consistency class	2
Temperature range, °C ¹⁾	-20 to +110
Base oil viscosity, mm ² /s at 40 °C	200
at 100 °C	16
Filling degree, % of free space in the bearing	25 to 35

¹⁾ For safe operating temperature, → section “Temperature range – the SKF traffic light concept”, starting on **page 232**

Fig. 4

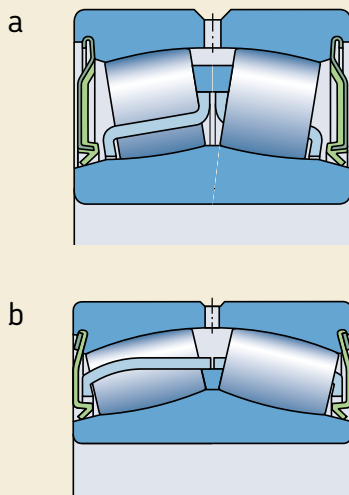

Fig. 5

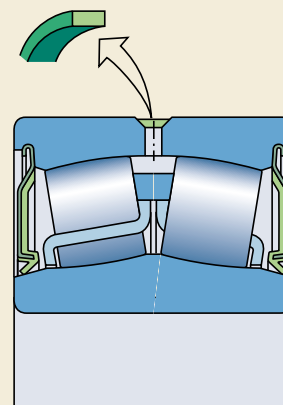
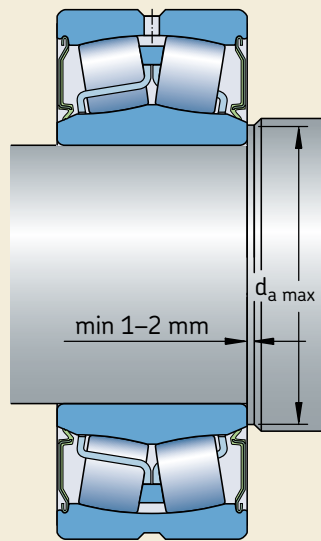
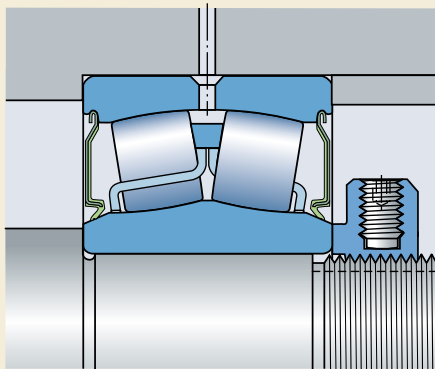

Fig. 6



a



b

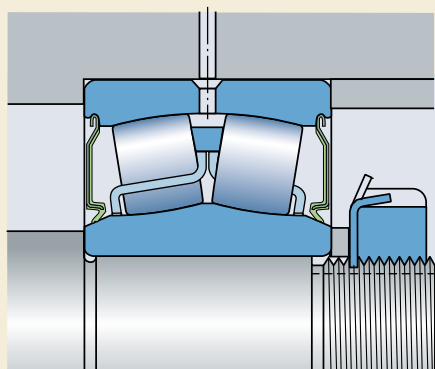

c

Sealed bearings do not need to be relubricated when the operating temperature does not exceed 70 °C and the rotational speed is below 50 % of the limiting speed listed in the product table. When temperature and/or speeds are high, relubrication with a similar grease with lithium thickener is recommended (→ **table 1**). In this case the polymer band, which covers the lubrication holes in the outer ring must be removed before mounting (→ **fig. 5**). Note that only a small amount of grease is needed to relubricate sealed bearings. The grease should be pressed in slowly through the lubrication holes in the outer ring while the bearing is rotating. Excessive pressure should be avoided so as not to damage the seals.

The internal design of a sealed bearing corresponds to that of an open bearing. The external dimensions are also the same except for bearings based on the 222 and 223 series. These bearings are slightly wider and carry the series designation BS2-22 and BS2-23 respectively.

Sealed bearings are available with a cylindrical bore as standard. However most bearings in the BS2-22 series are available with a tapered bore as well. Every sealed bearing can be supplied with a tapered bore to special order.

To prevent interference with the seal, the diameter of the shaft abutment should not exceed $d_{a \max}$ at least for the 1 to 2 mm closest to the bearing (→ **fig. 6a**).

If the bearings are secured axially on the shaft by a lock nut, SKF recommends using a KMFE lock nut (→ **fig. 6b**) or to position an intermediate ring between the bearing and the lock nut (→ **fig. 6c**).

Warning

Seals made of fluoro rubber exposed to extreme temperatures above 300 °C give off hazardous fumes. Therefore the safety recommendations mentioned in the section “Seal materials”, starting on **page 142**, must be considered.

Spherical roller bearings

Bearings for vibratory applications

Vibratory applications, such as vibrating screens or exciters, induce accelerations of rollers and cages in the bearings. This puts extra demands on the bearing design. SKF spherical roller bearings for vibratory applications can withstand considerably higher accelerations than corresponding standard bearings. The permissible acceleration depends on the lubricant and the type of acceleration – rotating or linear acceleration.

Rotating acceleration

The bearing is subjected to a rotating outer ring load and a rotating acceleration field. This generates cyclic loads on the cages from the unloaded rollers. Typical examples are vibrating screens and planetary gears. Road rollers are subject to a mix of rotating and linear accelerations (→ **fig. 7a**).

Individual values for the permissible rotating accelerations are provided in the product table and are valid for oil lubricated bearings. The values are expressed in m/s^2 , where 28 g stands for $28 \times 9,81 = 275 \text{ m/s}^2$, for example.

Linear acceleration

The bearing is subjected to impact loads and thus linear accelerations. This causes hammering in the cage pockets by the unloaded rollers. A typical linear acceleration is generated when rail wheels are rolling over rail joints (→ **fig. 7b**). An analogous application using bearings for vibrating applications is a road roller where the roller is vibrating against a relatively hard surface.

Individual values for the permissible linear accelerations are provided in the product table and are valid for oil lubricated bearings. The values are expressed in m/s^2 , where 90 g stands for $90 \times 9,81 = 883 \text{ m/s}^2$, for example.

Fig. 7

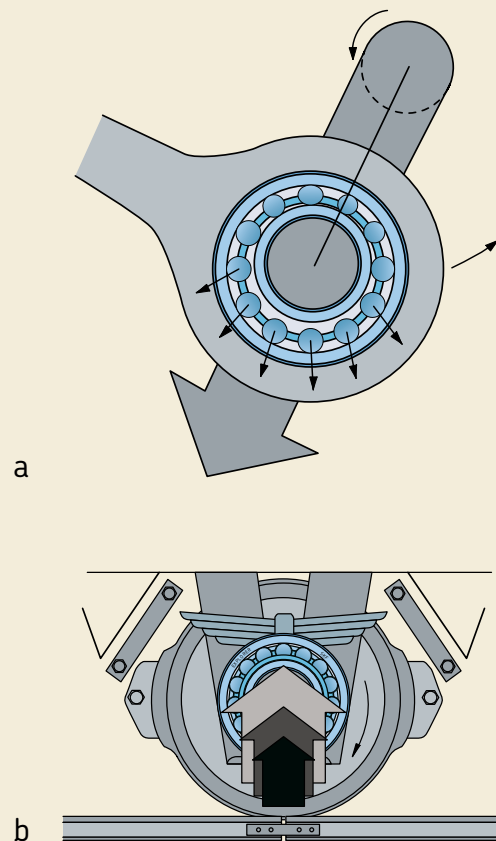
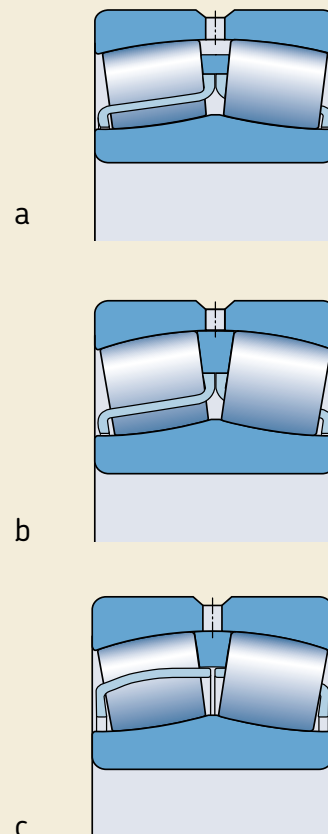

Fig. 8



Bearing design

SKF spherical roller bearings for vibratory applications have the same dimensions and performance values as bearings in the 223 series but have a C4 radial internal clearance as standard. They are available with either a cylindrical or tapered bore. To facilitate efficient lubrication all bearings are provided with an annular groove and three lubrication holes in the outer ring.

SKF spherical roller bearings for vibratory applications are, depending on their size, available in one of the designs described in the following (→ **fig. 8**).

E/VA405 (bearings with $d \leq 65$ mm)

Two surface hardened window-type steel cages, flangeless inner ring and guide ring centred on the inner ring.

E/VA 405 (bearings with $d > 65$ mm)

Two surface hardened window-type steel cages, flangeless inner ring and guide ring centred on the cages (**a**).

EJA/VA405 and CCJA/W33VA405

Two surface hardened window-type steel cages for bearings of EJA design (**b**) or CCJA design (**c**), flangeless inner ring and guide ring centred on the outer ring raceway.

EJA/VA406 and CCJA/W33VA406

These bearings have a PTFE coated cylindrical bore and have the same features as a VA405 design bearing. These bearings are intended for the non-locating bearing position in vibratory applications to prevent fretting corrosion between the shaft and the bore of the bearing. Shafts do not require special heat treatments or coatings.

System solutions for vibrating screens

In addition to single bearings for vibrating screens, SKF has developed fault detection and bearing systems that can extend performance, reduce maintenance and monitor machine condition in vibratory equipment. More information on this “SKF Copperhead system solution for vibrating screens” can be found on **page 1107**.

SKF Explorer class bearings

High performance SKF Explorer spherical roller bearings are shown with an asterisk in the product tables. SKF Explorer bearings retain the designation of the earlier standard bearings, e.g. 22220 E. However, each bearing and its box are marked with the name “EXPLORER”.

Special bearings

SKF produces a wide range of special spherical roller bearings to meet specific customer needs. These are, for example, bearings for

- printing machines, paper mills or coaters in high precision execution
- very arduous operating conditions as for example in continuous casting machines
- high temperature applications
- mounting with loose fit on roll necks
- railway vehicles.

For detailed information on these spherical roller bearings please contact SKF.

Fig. 9

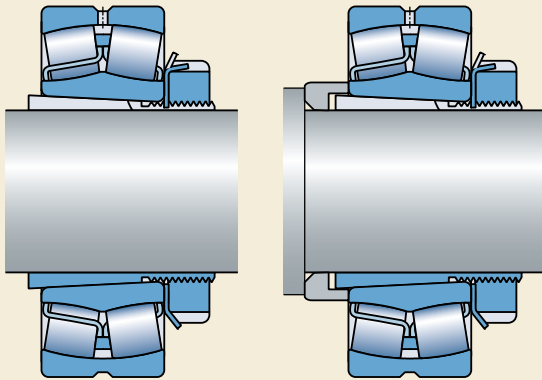

Bearings on sleeves

Spherical roller bearings with a tapered bore can be mounted on smooth or stepped shafts using

- an adapter sleeve (→ **fig. 9**), product table starting on **page 748**
- a withdrawal sleeve (→ **fig. 10**), product table starting on **page 762**.

The sleeves facilitate bearing mounting and dismounting and often simplify bearing arrangement design.

When sealed bearings are to be mounted on an adapter sleeve it is necessary to protect the sealing lips from being damaged. This can be done by

- using an E-design adapter sleeve (→ section “Adapter sleeves”, starting on **page 975**)
- inserting an intermediate ring between the bearing and the locking washer (→ **fig. 11**).

Fig. 10

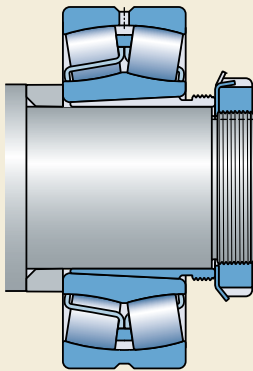
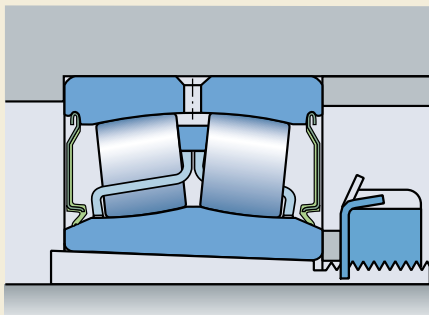

Fig. 11



Appropriate bearing housings

The combination of a spherical roller bearing and an appropriate bearing housing constitutes an economic, interchangeable and reliable bearing arrangement that meets the demands for easy maintenance. SKF produces appropriate housings in a variety of designs and sizes to suit a wide range of applications. The designs include

- split plummer (pillow) block housings
- one-piece plummer (pillow) block housings
- flanged housings
- take-up housings.

Detailed information on plummer block housings in the SNL 2, 3, 5 and 6 series (→ **fig. 12**) can be found in the section “Bearing housings”, starting on **page 1031**.

A brief description of all SKF housings is also provided in the section “Bearing housings” where only main design features are presented. Publications for detailed information are listed.

Fig. 12

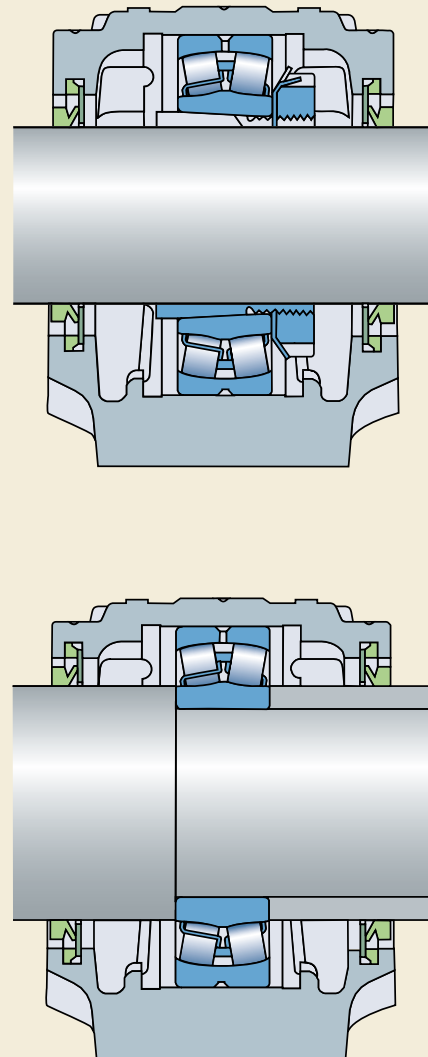

Bearing data – general

Dimensions

The boundary dimensions for spherical roller bearings are in accordance with ISO 15:1998. The dimensions of the adapter and withdrawal sleeves correspond to ISO 2982-1:1995.

Tolerances

SKF spherical roller bearings are manufactured as standard to Normal tolerances.

SKF Explorer spherical roller bearings up to and including 300 mm bore diameter are, however, produced to higher precision than the ISO Normal tolerances. For example

- the width tolerance is considerably tighter than the ISO Normal tolerance (→ **table 2**)
- the running accuracy is to tolerance class P5 as standard.

For larger bearing arrangements where running accuracy is a key operational parameter, SKF spherical roller bearings with P5 running accuracy are also available. These bearings are identified by the suffix C08. Their availability should be checked.

The tolerance for the bore and the outside diameter of SKF Explorer spherical roller bearings for vibratory applications have been reduced from Normal to P5 and P6 respectively.

The values of the tolerances are in accordance with ISO 492:2002 and can be found in **tables 3 to 5**, starting on **page 125**.

Table 2

Width tolerances for SKF Explorer spherical roller bearings with bore up to and including 300 mm

Bore diameter d		Width tolerances according to			
		SKF Standard		ISO Standard	
over	incl.	Δ_{Bs} high	low	Δ_{Bs} high	low
mm		μm			
18	50	0	-60	0	-120
50	80	0	-60	0	-150
80	120	0	-80	0	-200
120	180	0	-80	0	-250
180	250	0	-80	0	-300
250	300	0	-100	0	-350

Internal clearance

SKF spherical roller bearings are produced as standard with Normal radial internal clearance and most are also available with a greater C3 clearance. Many bearings can also be supplied with a smaller C2 clearance or the much greater C4 or C5 clearances.

SKF spherical roller bearings for vibratory applications are produced as standard with C4 clearance.

The radial internal clearance limits are listed for bearings with

- cylindrical bore in **table 3** and with
- tapered bore in **table 4**.

The clearance limits are in accordance with ISO 5753:1991 and are valid for bearings before mounting under zero measuring load.

Table 3

Radial internal clearance of spherical roller bearings with a cylindrical bore

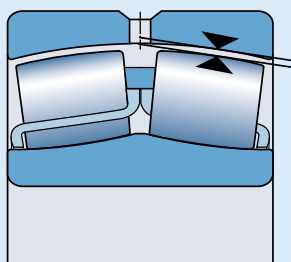

Bore diameter d		Radial internal clearance									
over	incl.	C2		Normal		C3		C4		C5	
		min	max	min	max	min	max	min	max	min	max
mm		µm									
18	24	10	20	20	35	35	45	45	60	60	75
24	30	15	25	25	40	40	55	55	75	75	95
30	40	15	30	30	45	45	60	60	80	80	100
40	50	20	35	35	55	55	75	75	100	100	125
50	65	20	40	40	65	65	90	90	120	120	150
65	80	30	50	50	80	80	110	110	145	145	185
80	100	35	60	60	100	100	135	135	180	180	225
100	120	40	75	75	120	120	160	160	210	210	260
120	140	50	95	95	145	145	190	190	240	240	300
140	160	60	110	110	170	170	220	220	280	280	350
160	180	65	120	120	180	180	240	240	310	310	390
180	200	70	130	130	200	200	260	260	340	340	430
200	225	80	140	140	220	220	290	290	380	380	470
225	250	90	150	150	240	240	320	320	420	420	520
250	280	100	170	170	260	260	350	350	460	460	570
280	315	110	190	190	280	280	370	370	500	500	630
315	355	120	200	200	310	310	410	410	550	550	690
355	400	130	220	220	340	340	450	450	600	600	750
400	450	140	240	240	370	370	500	500	660	660	820
450	500	140	260	260	410	410	550	550	720	720	900
500	560	150	280	280	440	440	600	600	780	780	1 000
560	630	170	310	310	480	480	650	650	850	850	1 100
630	710	190	350	350	530	530	700	700	920	920	1 190
710	800	210	390	390	580	580	770	770	1 010	1 010	1 300
800	900	230	430	430	650	650	860	860	1 120	1 120	1 440
900	1 000	260	480	480	710	710	930	930	1 220	1 220	1 570
1 000	1 120	290	530	530	780	780	1 020	1 020	1 330	1 330	1 720
1 120	1 250	320	580	580	860	860	1 120	1 120	1 460	1 460	1 870
1 250	1 400	350	640	640	950	950	1 240	1 240	1 620	1 620	2 060
1 400	1 600	400	720	720	1 060	1 060	1 380	1 380	1 800	1 800	2 300
1 600	1 800	450	810	810	1 180	1 180	1 550	1 550	2 000	2 000	2 550

Please refer to page 137 for the definition of radial internal clearance

Spherical roller bearings

Table 4

Radial internal clearance of spherical roller bearings with a tapered bore

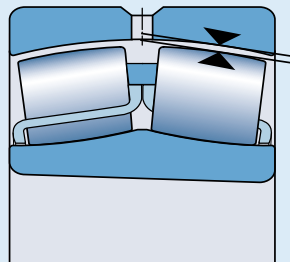

Bore diameter d		Radial internal clearance									
over	incl.	C2		Normal		C3		C4		C5	
		min	max	min	max	min	max	min	max	min	max
mm		µm									
24	30	20	30	30	40	40	55	55	75	–	–
30	40	25	35	35	50	50	65	65	85	85	105
40	50	30	45	45	60	60	80	80	100	100	130
50	65	40	55	55	75	75	95	95	120	120	160
65	80	50	70	70	95	95	120	120	150	150	200
80	100	55	80	80	110	110	140	140	180	180	230
100	120	65	100	100	135	135	170	170	220	220	280
120	140	80	120	120	160	160	200	200	260	260	330
140	160	90	130	130	180	180	230	230	300	300	380
160	180	100	140	140	200	200	260	260	340	340	430
180	200	110	160	160	220	220	290	290	370	370	470
200	225	120	180	180	250	250	320	320	410	410	520
225	250	140	200	200	270	270	350	350	450	450	570
250	280	150	220	220	300	300	390	390	490	490	620
280	315	170	240	240	330	330	430	430	540	540	680
315	355	190	270	270	360	360	470	470	590	590	740
355	400	210	300	300	400	400	520	520	650	650	820
400	450	230	330	330	440	440	570	570	720	720	910
450	500	260	370	370	490	490	630	630	790	790	1 000
500	560	290	410	410	540	540	680	680	870	870	1 100
560	630	320	460	460	600	600	760	760	980	980	1 230
630	710	350	510	510	670	670	850	850	1 090	1 090	1 360
710	800	390	570	570	750	750	960	960	1 220	1 220	1 500
800	900	440	640	640	840	840	1 070	1 070	1 370	1 370	1 690
900	1 000	490	710	710	930	930	1 190	1 190	1 520	1 520	1 860
1 000	1 120	530	770	770	1 030	1 030	1 300	1 300	1 670	1 670	2 050
1 120	1 250	570	830	830	1 120	1 120	1 420	1 420	1 830	1 830	2 250
1 250	1 400	620	910	910	1 230	1 230	1 560	1 560	2 000	2 000	2 450
1 400	1 600	680	1 000	1 000	1 350	1 350	1 720	1 720	2 200	2 200	2 700
1 600	1 800	750	1 110	1 110	1 500	1 500	1 920	1 920	2 400	2 400	2 950

Please refer to page 137 for the definition of radial internal clearance

Misalignment

The design of spherical roller bearings is such that they are inherently self-aligning, i.e. angular misalignment between the outer ring and inner ring can be accommodated without any negative effect on bearing performance. Under normal operating conditions (load ratios of $C/P > 10$) and when misalignment is constant in position with respect to the outer ring, the guideline values for permissible misalignment provided in **table 5** apply. Whether these values can be fully exploited or not depends on the design of the bearing arrangement, the type of seals used etc.

When the position of the misalignment is not constant with respect to the bearing outer ring, e.g. in

- vibrating screens with rotating imbalance and therefore rotating deflection of the shaft (→ **fig. 13**)
- deflection-compensating rolls of paper machines where the stationary shaft is bent,

additional sliding is caused in the bearing under the operating conditions. Therefore, with reference to bearing friction and associated heat generation, it is recommended that misalignment of the inner ring with respect to the outer ring should not exceed a few tenths of a degree.

Sealed bearings can accommodate angular misalignments of the shaft with respect to the housing of up to approximately $0,5^\circ$. Provided the guideline value is not exceeded, there will be no detrimental effect on the efficiency of the seals.

Table 5

Permissible angular misalignment	
Bearing series Sizes ¹⁾	Permissible angular misalignment
–	degrees
Series 213	2
Series 222 Sizes < 52 Sizes ≥ 52	2 1,5
Series 223	3
Series 230 Sizes < 56 Sizes ≥ 56	2 2,5
Series 231 Sizes < 60 Sizes ≥ 60	2 3
Series 232 Sizes < 52 Sizes ≥ 52	2,5 3,5
Series 238	1,5
Series 239	1,5
Series 240	2
Series 241 Sizes < 64 Sizes ≥ 64	2,5 3,5
Series 248	1,5
Series 249	2,5

¹⁾ Last two figures of bearing designations

Fig. 13

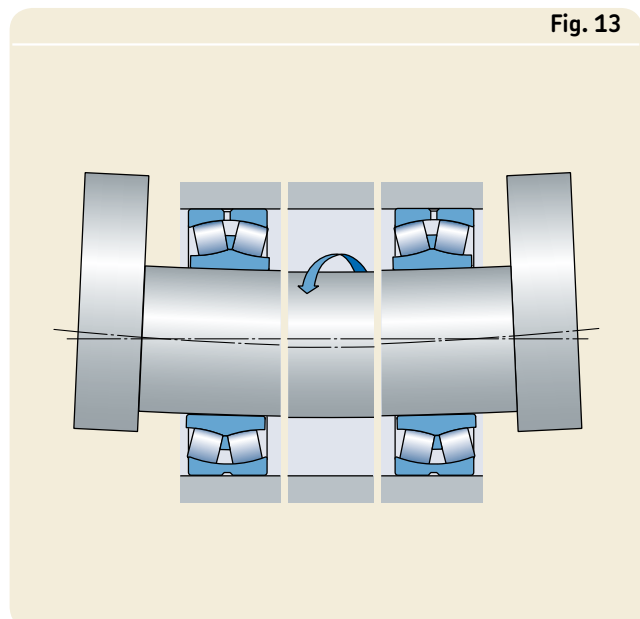

Spherical roller bearings

Influence of operating temperature on bearing material

All SKF spherical roller bearings undergo a special heat treatment so that they can be operated at higher temperatures for longer periods, without the occurrence of inadmissible dimensional changes. For example, a temperature of +200 °C for 2 500 h, or for short periods at even higher temperatures, is permitted.

Axial load carrying capacity

Because of their special internal design, SKF spherical roller bearings are able to accommodate heavy axial loads and even purely axial loads.

Axial load carrying capacity of bearings mounted on an adapter sleeve

If spherical roller bearings with adapter sleeves are mounted on smooth shafts with no fixed abutment, the magnitude of the axial load that can be supported is determined by the friction between the shaft and sleeve. Provided the bearings are correctly mounted, the permissible axial load can be calculated from

$$F_{ap} = 0,003 B d$$

where

F_{ap} = maximum permissible axial load, kN

B = bearing width, mm

d = bearing bore diameter, mm

Minimum load

In order to provide satisfactory operation, spherical roller bearings, like all ball and roller bearings, must always be subjected to a given minimum load, particularly if they are to operate at high speeds or are subjected to high accelerations or rapid changes in the direction of load. Under such conditions, the inertia forces of the rollers and cage(s), and the friction in the lubricant, can have a detrimental influence on the rolling conditions in the bearing arrangement and may cause damaging sliding movements to occur between the rollers and raceways.

The requisite minimum load to be applied to spherical roller bearings can be estimated using

$$P_m = 0,01 C_0$$

where

P_m = equivalent minimum load, kN

C_0 = basic static load rating, kN

(→ product tables)

In some applications it is not possible to reach or exceed the requisite minimum load. However, if the bearing is oil lubricated lower minimum loads are permissible. These loads can be calculated when $n/n_r \leq 0,3$ from

$$P_m = 0,003 C_0$$

and when $0,3 < n/n_r \leq 2$ from

$$P_m = 0,003 C_0 \left(1 + 2 \sqrt{\frac{n}{n_r} - 0,3} \right)$$

where

P_m = equivalent minimum load, kN

C_0 = basic static load rating, kN

(→ product tables)

n = rotational speed, r/min

n_r = reference speed, r/min

(→ product tables)

When starting up at low temperatures or when the lubricant is highly viscous, even greater minimum loads than $P_m = 0,01 C_0$ may be required. The weight of the components supported by the bearing, together with external forces, generally exceeds the requisite minimum load. If this is not the case, the spherical roller bearing must be subjected to an additional radial load.

NoWear spherical roller bearings have proven to give reliable operation at very low loads. They can withstand longer periods of insufficient lubrication, sudden variations in load and rapid speed changes (→ page 943).

Equivalent dynamic bearing load

$$P = F_r + Y_1 F_a \quad \text{when } F_a/F_r \leq e$$

$$P = 0,67 F_r + Y_2 F_a \quad \text{when } F_a/F_r > e$$

The values of the calculation factors e , Y_1 and Y_2 can be found in the product tables.

Equivalent static bearing load

$$P_0 = F_r + Y_0 F_a$$

The value of the calculation factor Y_0 can be found in the product tables.

Supplementary designations

The designation suffixes used to identify certain features of SKF spherical roller bearings are explained in the following. The suffixes used to identify bearing (and cage) design, e.g. CC or E, are not included here as they are explained in the section "Standard bearings" on **page 696**.

C2	Radial internal clearance smaller than Normal
C3	Radial internal clearance greater than Normal
C4	Radial internal clearance greater than C3
C5	Radial internal clearance greater than C4
C08	Heightened running accuracy to ISO tolerance class 5
C083	C08 + C3
C084	C08 + C4
2CS	Sheet steel reinforced contact seal of acrylonitrile-butadiene rubber (NBR) on both sides of the bearing. Annular groove and three lubrication holes in the outer ring covered with a polymer band. Lubricated with an extreme pressure bearing grease according to table 1 on page 698
2CS2	Sheet steel reinforced contact seal of fluoro rubber (FKM) on both sides of the bearing. Annular groove and three lubrication holes in the outer ring; covered with a polymer band. Lubricated with a polyurea high-temperature grease

2CS5	Sheet steel reinforced contact seal of hydrogenated acrylonitrile-butadiene rubber (HNBR) on both sides of the bearing. Otherwise as 2CS2
HA3	Case-hardened inner ring
K	Tapered bore, taper 1:12
K30	Tapered bore, taper 1:30
P5	Dimensional and running accuracy to ISO tolerance class 5
P6	Dimensional and running accuracy to ISO tolerance class 6
P62	P6 + C2
VA405	Bearings for vibratory applications with surface hardened cages
VA406	VA405 and PTFE-coated bore
VE552(E)	Outer ring with three equally spaced threaded holes in one side face to accommodate hoisting tackle; the E indicates that appropriate eye bolts are supplied with the bearings
VE553(E)	As VE552 but with threaded holes in both side faces
VG114	Surface hardened pressed steel cage
VQ424	Running accuracy better than C08
VT143	Grease fill with an extreme pressure grease according to table 1 on page 698
W	Without annular groove and lubrication holes in outer ring
W20	Three lubrication holes in the outer ring
W26	Six lubrication holes in the inner ring
W33	Annular groove and three lubrication holes in the outer ring
W33X	Annular groove and six lubrication holes in the outer ring
W64	Solid Oil filling
W77	Plugged W33 lubrication holes
W513	W26 + W33
235220	Case-hardened inner ring with helical groove in the bore

Mounting bearings with a tapered bore

Bearings with a tapered bore are always mounted with an interference fit. The reduction in radial internal clearance, or the axial displacement of the inner ring on its tapered seating is used as a measure of the degree of interference.

Suitable methods for mounting spherical roller bearings with tapered bore are:

- Measuring the clearance reduction.
- Measuring the lock nut tightening angle.
- Measuring the axial drive-up.
- Measuring the inner ring expansion.

Small bearings with a bore diameter up to 100 mm can be properly mounted by measuring the lock nut tightening angle.

For larger bearings the SKF Drive-up Method is recommended. This method is more accurate and takes less time than the procedure based on clearance reduction or the lock nut tightening angle. Measuring the inner ring expansion, i.e. applying the SensorMount® Method, enables large size bearings to be mounted simply, quickly and accurately, since a sensor is integrated into the bearing inner ring.

Measuring clearance reduction

The method using feeler gauges for measuring the radial internal clearance before and after mounting bearings is applicable for medium and large-sized bearings (→ **fig. 14**). Before

measuring, rotate the inner or outer ring a few times. Make sure that both bearing rings and the roller complement are centrally arranged with respect to each other.

For the first measurement, a blade should be selected, that is slightly thinner than the minimum value for the clearance. During the measurement, the blade should be moved back and forth until it can be inserted to the middle of the roller. The procedure should be repeated, using slightly thicker blades each time, until a certain resistance is felt when moving between

- outer ring and uppermost roller (**a**) – before mounting
- outer ring and lowest roller (**b**) – after mounting.

For large bearings, especially those having a rather thin-walled outer ring, the measurements may be affected by the elastic deformation of the rings, caused by the weight of the bearing or the force to draw the feeler gauge blade through the gap between the raceway and an unloaded roller. To establish in such cases the “true” clearance before and after mounting, the following procedure should be followed (**c**):

- Measure the clearance “c” at the 12 o’clock position for a standing bearing or at the 6 o’clock position for a bearing hanging on a journal.
- Measure clearance “a” at the 9 o’clock position and “b” at the 3 o’clock position without the bearing being moved.

Fig. 14

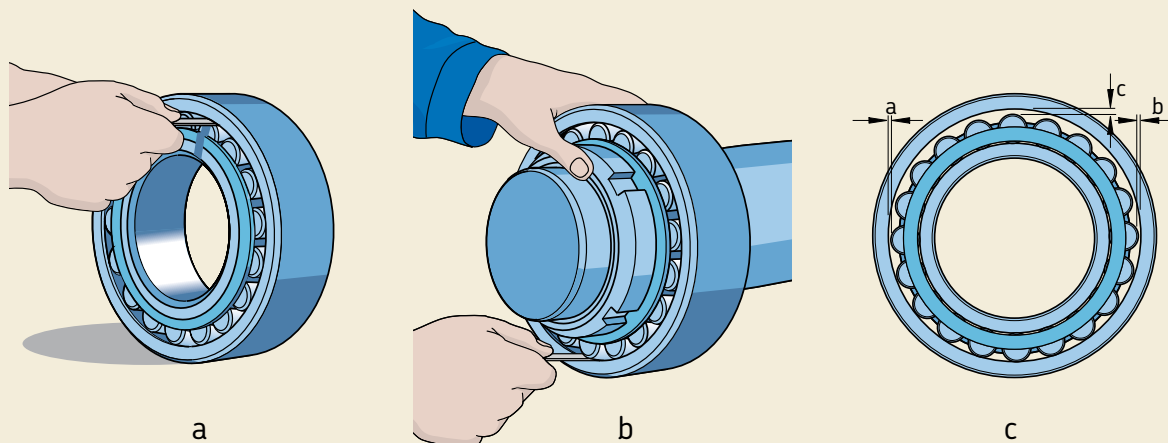
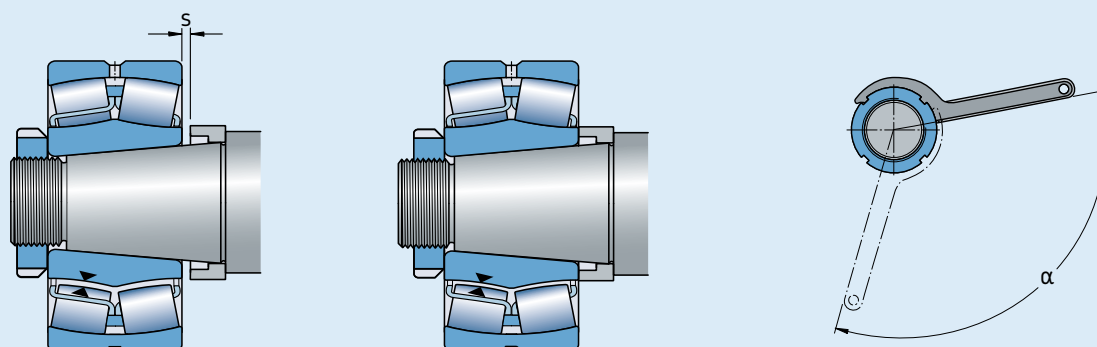

Table 6

Recommended values for reduction of radial internal clearance, axial drive-up and lock nut tightening angle



Bore diameter d		Reduction of radial internal clearance		Axial drive-up ¹⁾ s				Permissible residual ²⁾ radial clearance after mounting bearings with initial clearance			Lock nut tightening angle α
over	incl.	min	max	Taper 1:12		Taper 1:30		Normal	C3	C4	Taper 1:12
mm		mm		mm				mm			degrees
24	30	0,015	0,020	0,3	0,35	–	–	0,015	0,020	0,035	110
30	40	0,020	0,025	0,35	0,4	–	–	0,015	0,025	0,040	120
40	50	0,025	0,030	0,4	0,45	–	–	0,020	0,030	0,050	130
50	65	0,030	0,040	0,45	0,6	3	4	0,025	0,035	0,055	110
65	80	0,040	0,050	0,6	0,7	3,2	4,2	0,025	0,040	0,070	130
80	100	0,045	0,060	0,7	0,9	1,7	2,2	0,035	0,050	0,080	150
100	120	0,050	0,070	0,75	1,1	1,9	2,7	0,050	0,065	0,100	–
120	140	0,065	0,090	1,1	1,4	2,7	3,5	0,055	0,080	0,110	–
140	160	0,075	0,100	1,2	1,6	3	4	0,055	0,090	0,130	–
160	180	0,080	0,110	1,3	1,7	3,2	4,2	0,060	0,100	0,150	–
180	200	0,090	0,130	1,4	2	3,5	5	0,070	0,100	0,160	–
200	225	0,100	0,140	1,6	2,2	4	5,5	0,080	0,120	0,180	–
225	250	0,110	0,150	1,7	2,4	4,2	6	0,090	0,130	0,200	–
250	280	0,120	0,170	1,9	2,7	4,7	6,7	0,100	0,140	0,220	–
280	315	0,130	0,190	2	3	5	7,5	0,110	0,150	0,240	–
315	355	0,150	0,210	2,4	3,3	6	8,2	0,120	0,170	0,260	–
355	400	0,170	0,230	2,6	3,6	6,5	9	0,130	0,190	0,290	–
400	450	0,200	0,260	3,1	4	7,7	10	0,130	0,200	0,310	–
450	500	0,210	0,280	3,3	4,4	8,2	11	0,160	0,230	0,350	–
500	560	0,240	0,320	3,7	5	9,2	12,5	0,170	0,250	0,360	–
560	630	0,260	0,350	4	5,4	10	13,5	0,200	0,290	0,410	–
630	710	0,300	0,400	4,6	6,2	11,5	15,5	0,210	0,310	0,450	–
710	800	0,340	0,450	5,3	7	13,3	17,5	0,230	0,350	0,510	–
800	900	0,370	0,500	5,7	7,8	14,3	19,5	0,270	0,390	0,570	–
900	1 000	0,410	0,550	6,3	8,5	15,8	21	0,300	0,430	0,640	–
1 000	1 120	0,450	0,600	6,8	9	17	23	0,320	0,480	0,700	–
1 120	1 250	0,490	0,650	7,4	9,8	18,5	25	0,340	0,540	0,770	–
1 250	1 400	0,550	0,720	8,3	10,8	21	27	0,360	0,590	0,840	–
1 400	1 600	0,600	0,800	9,1	11,9	22,7	29,8	0,400	0,650	0,920	–
1 600	1 800	0,670	0,900	10,2	13,4	25,4	33,6	0,440	0,720	1,020	–

¹⁾ Valid only for solid steel shafts and general application. Not valid for the SKF Drive-up Method

²⁾ The residual clearance must be checked in cases where the initial radial internal clearance is in the lower half of the tolerance range, and where large temperature differentials between the bearing rings can arise in operation. The residual clearance must not be less than the minimum values quoted above

Spherical roller bearings

- Obtain the “true” radial internal clearance with relatively good accuracy from $0,5(a+b+c)$.

Recommended values for reduction of radial internal clearance are provided in **table 6** on **page 711**.

Measuring the lock nut tightening angle

Mounting small to medium-size bearings on tapered seatings is easy when the tightening angle α of the lock nut (\rightarrow **fig. 15**) and the method that is described in the following is used. Recommended values for the tightening angle α are provided in **table 6** on **page 711**.

Before starting the final tightening procedure, the bearing should be pushed up on the tapered seating until the bore of the bearing or sleeve is in contact with the seating on the shaft around its whole circumference, i.e. the bearing inner ring cannot be rotated relatively to the shaft. By then turning the nut through the given angle α , the bearing will be pressed up the tapered seating. The residual clearance of the bearing should be checked, if possible.

Then unscrew the nut, place the locking washer in position and tighten the nut firmly again. Lock the nut by bending one of the locking washer tabs into the nut slot or by attaching the locking clip to the nut.

Measuring the axial drive-up

Mounting bearings with a tapered bore can be done by measuring the axial drive-up of the inner ring on its seating. Recommended values for the required axial drive-up “s” for general applications are provided in **table 6** on **page 711**.

The most suitable method in this case is the SKF Drive-up Method. This mounting method provides a very reliable and easy way to determine the starting position for a bearing from which the axial displacement is to be measured. For that, the following mounting tools (\rightarrow **fig. 16**) must be used

- an SKF hydraulic nut of the HMV .. E design (**a**)
- a hydraulic pump (**b**)
- a pressure gauge (**c**), appropriate to the mounting conditions
- a dial gauge (**d**).

Fig. 15

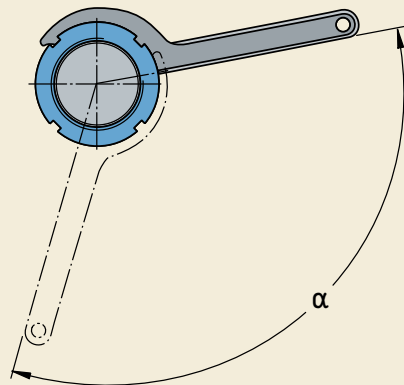

Fig. 16

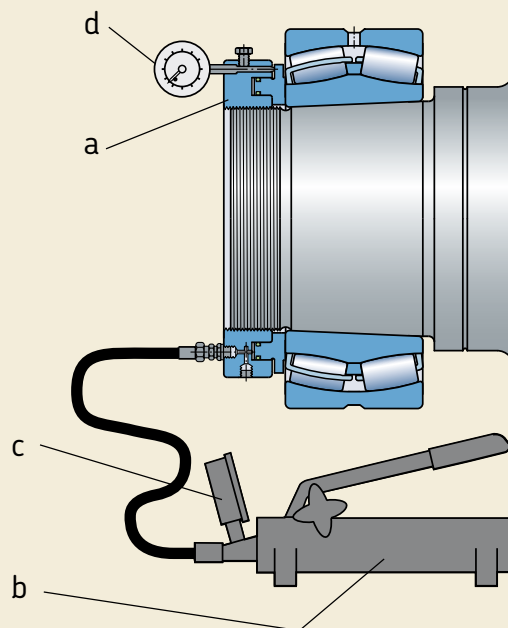
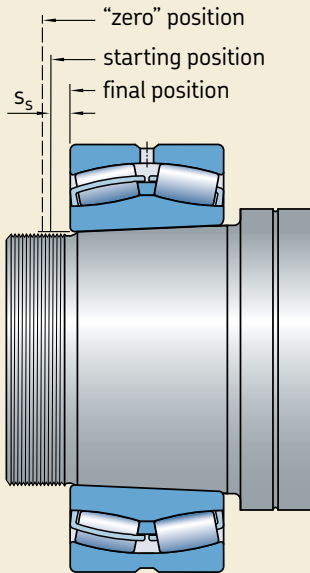
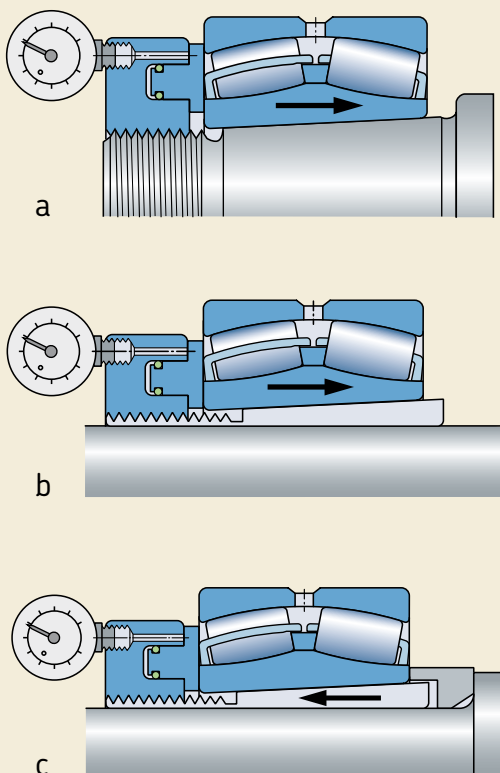

Fig. 17

Applying the SKF Drive-up Method, the bearing is pushed up its seating to a defined starting position (→ **fig. 17**) using a given oil pressure (corresponding to a given drive-up force) in the hydraulic nut. In this way, part of the desired reduction in radial internal clearance is achieved. The oil pressure is monitored by the pressure gauge. The bearing is then driven up from the defined starting position through a given distance to its final position. The axial displacement “ s_s ” is accurately determined using the dial gauge mounted on the hydraulic nut.

SKF has determined values of the requisite oil pressure and the axial displacement for individual bearings. These values apply to bearing arrangements (→ **fig. 18**) with

- one sliding interface (**a**) and (**b**) or
- two sliding interfaces (**c**).

Fig. 18

Spherical roller bearings

Measuring the inner ring expansion

Measuring inner ring expansion enables large-size spherical roller bearings with a tapered bore to be mounted simply, quickly and accurately without measuring the radial internal clearance before and after mounting. The SKF Sensor-Mount Method uses a sensor, integrated into the bearing inner ring, and a dedicated hand-held indicator (→ **fig. 19**).

The bearing is driven up the tapered seating using common SKF mounting tools. The information from the sensor is processed by the indicator. Inner ring expansion is displayed as the relationship between the clearance reduction (mm) and the bearing bore diameter (m).

Aspects like bearing size, smoothness, shaft material or design – solid or hollow – do not need to be considered.

For detailed information about the SKF Sensor Mount Method please contact the SKF application engineering service.

Additional mounting information

Additional information on mounting spherical roller bearings in general or with the aid of the SKF Drive-up Method can be found

- in the handbook “SKF Drive-up Method” on CD-ROM
- in the “SKF Interactive Engineering Catalogue” on CD-ROM or online at www.skf.com
- online at www.skf.com/mount.

Fig. 19

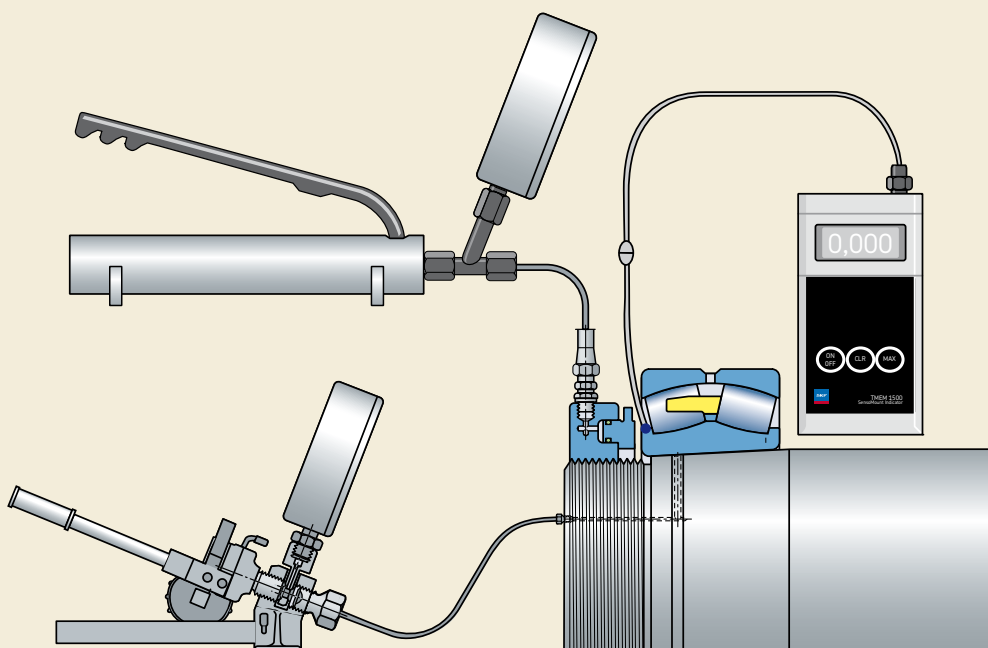

Spherical roller bearings

d 20 – 70 mm

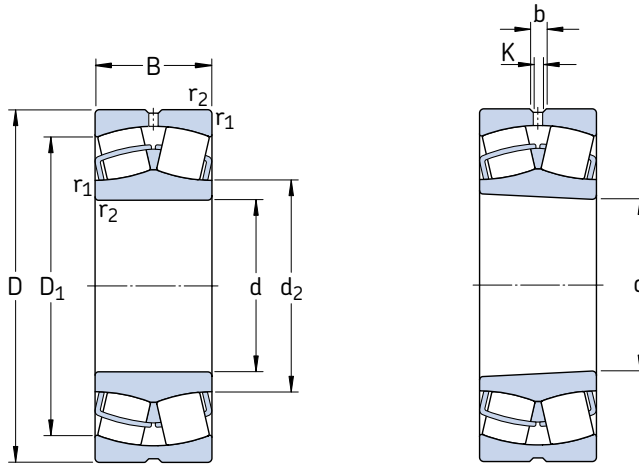

Cylindrical bore

Tapered bore

Principal dimensions			Basic load ratings dynamic static		Fatigue load limit	Speed ratings		Mass	Designations	
d	D	B	C	C ₀	P _u	Refer- ence speed	Limiting speed		Bearing with cylindrical bore	tapered bore
mm			kN		kN	r/min		kg	–	
20	52	18	49	44	4,75	13 000	17 000	0,28	* 22205/20 E	–
25	52	18	49	44	4,75	13 000	17 000	0,26	* 22205 E	* 22205 EK
	62	17	41,4	41,5	4,55	8 500	12 000	0,28	21305 CC	–
30	62	20	64	60	6,4	10 000	14 000	0,29	* 22206 E	* 22206 EK
	72	19	55,2	61	6,8	7 500	10 000	0,41	21306 CC	21306 CCK
35	72	23	86,5	85	9,3	9 000	12 000	0,45	* 22207 E	* 22207 EK
	80	21	65,6	72	8,15	6 700	9 500	0,55	21307 CC	21307 CCK
40	80	23	96,5	90	9,8	8 000	11 000	0,53	* 22208 E	* 22208 EK
	90	23	104	108	11,8	7 000	9 500	0,75	* 21308 E	* 21308 EK
	90	33	150	140	15	6 000	8 000	1,05	* 22308 E	* 22308 EK
45	85	23	102	98	10,8	7 500	10 000	0,58	* 22209 E	* 22209 EK
	100	25	125	127	13,7	6 300	8 500	0,99	* 21309 E	* 21309 EK
	100	36	183	183	19,6	5 300	7 000	1,40	* 22309 E	* 22309 EK
50	90	23	104	108	11,8	7 000	9 500	0,63	* 22210 E	* 22210 EK
	110	27	156	166	18,6	5 600	7 500	1,35	* 21310 E	* 21310 EK
	110	40	220	224	24	4 800	6 300	1,90	* 22310 E	* 22310 EK
55	100	25	125	127	13,7	6 300	8 500	0,84	* 22211 E	* 22211 EK
	120	29	156	166	18,6	5 600	7 500	1,70	* 21311 E	* 21311 EK
	120	43	270	280	30	4 300	5 600	2,45	* 22311 E	* 22311 EK
60	110	28	156	166	18,6	5 600	7 500	1,15	* 22212 E	* 22212 EK
	130	31	212	240	26,5	4 800	6 300	2,10	* 21312 E	* 21312 EK
	130	46	310	335	36,5	4 000	5 300	3,10	* 22312 E	* 22312 EK
65	100	35	132	173	20,4	4 300	6 300	0,95	* 24013 CC/W33	* 24013 CCK30/W33
	120	31	193	216	24	5 000	7 000	1,55	* 22213 E	* 22213 EK
	140	33	236	270	29	4 300	6 000	2,55	* 21313 E	* 21313 EK
	140	48	340	360	38	3 800	5 000	3,75	* 22313 E	* 22313 EK
70	125	31	208	228	25,5	5 000	6 700	1,55	* 22214 E	* 22214 EK
	150	35	285	325	34,5	4 000	5 600	3,10	* 21314 E	* 21314 EK
	150	51	400	430	45	3 400	4 500	4,55	* 22314 E	* 22314 EK

* SKF Explorer bearing

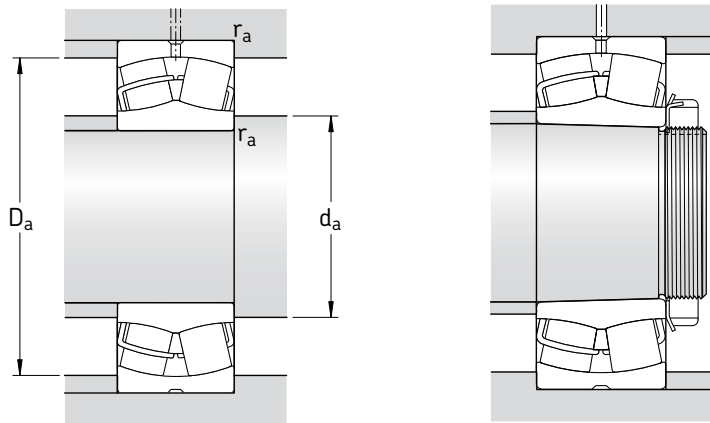

Dimensions						Abutment and fillet dimensions			Calculation factors			
d	d ₂	D ₁	b	K	r _{1,2} min	d _a min	D _a max	r _a max	e	Y ₁	Y ₂	Y ₀
mm						mm			-			
20	31,2	44,2	3,7	2	1	25,6	46,4	1	0,35	1,9	2,9	1,8
	35,7	50,7	-	-	1,1	32	55	1	0,30	2,3	3,4	2,2
30	37,5	53	3,7	2	1	35,6	56,4	1	0,31	2,2	3,3	2,2
	43,3	58,8	-	-	1,1	37	65	1	0,27	2,5	3,7	2,5
35	44,5	61,8	3,7	2	1,1	42	65	1	0,31	2,2	3,3	2,2
	47,2	65,6	-	-	1,5	44	71	1,5	0,28	2,4	3,6	2,5
40	49,1	69,4	5,5	3	1,1	47	73	1	0,28	2,4	3,6	2,5
	59,9	79,8	5,5	3	1,5	49	81	1,5	0,24	2,8	4,2	2,8
	49,7	74,3	5,5	3	1,5	49	81	1,5	0,37	1,8	2,7	1,8
45	54,4	74,4	5,5	3	1,1	52	78	1	0,26	2,6	3,9	2,5
	65,3	88	5,5	3	1,5	54	91	1,5	0,24	2,8	4,2	2,8
	56,4	83,4	5,5	3	1,5	54	91	1,5	0,37	1,8	2,7	1,8
50	59,9	79	5,5	3	1,1	57	83	1	0,24	2,8	4,2	2,8
	71,6	96,8	5,5	3	2	61	99	2	0,24	2,8	4,2	2,8
	62,1	91,9	5,5	3	2	61	99	2	0,37	1,8	2,7	1,8
55	65,3	88	5,5	3	1,5	64	91	1,5	0,24	2,8	4,2	2,8
	71,6	96,2	5,5	3	2	66	109	2	0,24	2,8	4,2	2,8
	70,1	102	5,5	3	2	66	109	2	0,35	1,9	2,9	1,8
60	71,6	96,5	5,5	3	1,5	69	101	1,5	0,24	2,8	4,2	2,8
	87,8	115	5,5	3	2,1	72	118	2	0,22	3	4,6	2,8
	77,9	110	8,3	4,5	2,1	72	118	2	0,35	1,9	2,9	1,8
65	73,8	87,3	3,7	2	1,1	71	94	1	0,27	2,5	3,7	2,5
	77,6	106	5,5	3	1,5	74	111	1,5	0,24	2,8	4,2	2,8
	94,7	124	5,5	3	2,1	77	128	2	0,22	3	4,6	2,8
	81,6	118	8,3	4,5	2,1	77	128	2	0,35	1,9	2,9	1,8
70	83	111	5,5	3	1,5	79	116	1,5	0,23	2,9	4,4	2,8
	101	133	5,5	3	2,1	82	138	2	0,22	3	4,6	2,8
	90,3	128	8,3	4,5	2,1	82	138	2	0,33	2	3	2

Spherical roller bearings

d 75 – 110 mm

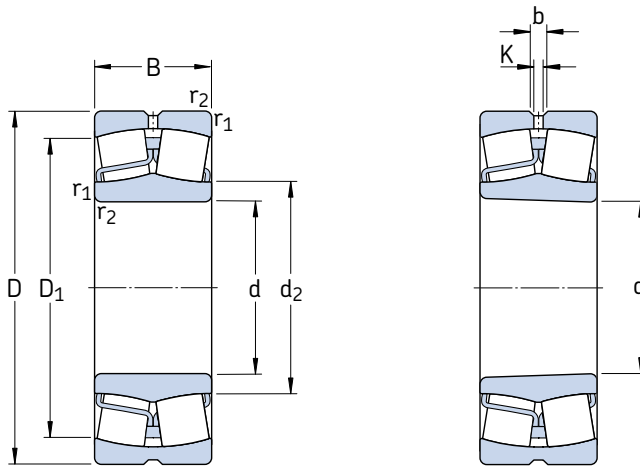

Cylindrical bore

Tapered bore

Principal dimensions			Basic load ratings		Fatigue load limit P_u	Speed ratings		Mass	Designations	
d	D	B	dynamic	static		Refer- ence speed	Limiting speed		Bearing with cylindrical bore	tapered bore
mm			kN		kN	r/min		kg	–	
75	115	40	173	232	28,5	3 800	5 300	1,55	* 24015 CC/W33	* 24015 CCK30/W33
	130	31	212	240	26,5	4 800	6 300	1,70	* 22215 E	* 22215 EK
	160	37	285	325	34,5	4 000	5 600	3,75	* 21315 E	* 21315 EK
	160	55	440	475	48	3 200	4 300	5,55	* 22315 E	* 22315 EK
80	140	33	236	270	29	4 300	6 000	2,10	* 22216 E	* 22216 EK
	170	39	325	375	39	3 800	5 300	4,45	* 21316 E	* 21316 EK
	170	58	490	540	54	3 000	4 000	6,60	* 22316 E	* 22316 EK
85	150	36	285	325	34,5	4 000	5 600	2,65	* 22217 E	* 22217 EK
	180	41	325	375	39	3 800	5 300	5,20	* 21317 E	* 21317 EK
	180	60	550	620	61	2 800	3 800	7,65	* 22317 E	* 22317 EK
90	160	40	325	375	39	3 800	5 300	3,40	* 22218 E	* 22218 EK
	160	52,4	355	440	48	2 800	3 800	4,65	* 23218 CC/W33	* 23218 CCK/W33
	190	43	380	450	46,5	3 600	4 800	6,10	* 21318 E	* 21318 EK
	190	64	610	695	67	2 600	3 600	9,05	* 22318 E	* 22318 EK
95	170	43	380	450	46,5	3 600	4 800	4,15	* 22219 E	* 22219 EK
	200	45	425	490	49	3 400	4 500	7,05	* 21319 E	* 21319 EK
	200	67	670	765	73,5	2 600	3 400	10,5	* 22319 E	* 22319 EK
100	150	50	285	415	45,5	2 800	4 000	3,15	* 24020 CC/W33	* 24020 CCK30/W33
	165	52	365	490	53	3 000	4 000	4,55	* 23120 CC/W33	* 23120 CCK/W33
	165	65	455	640	68	2 400	3 200	5,65	* 24120 CC/W33	* 24120 CCK30/W33
	180	46	425	490	49	3 400	4 500	4,90	* 22220 E	* 22220 EK
	180	60,3	475	600	63	2 400	3 400	6,85	* 23220 CC/W33	* 23220 CCK/W33
110	215	47	425	490	49	3 400	4 500	8,60	* 21320 E	* 21320 EK
	215	73	815	950	88	2 400	3 000	13,5	* 22320 E	* 22320 EK
	170	45	310	440	46,5	3 400	4 300	3,80	* 23022 CC/W33	* 23022 CCK/W33
	170	60	415	620	67	2 400	3 600	5,00	* 24022 CC/W33	* 24022 CCK30/W33
	180	56	430	585	61	2 800	3 600	5,75	* 23122 CC/W33	* 23122 CCK/W33
110	180	69	520	750	78	2 200	3 000	7,10	* 24122 CC/W33	* 24122 CCK30/W33
	200	53	560	640	63	3 000	4 000	7,00	* 22222 E	* 22222 EK
	200	69,8	600	765	76,5	2 200	3 200	9,85	* 23222 CC/W33	* 23222 CCK/W33
	240	80	950	1 120	100	2 000	2 800	18,4	* 22322 E	* 22322 EK

* SKF Explorer bearing

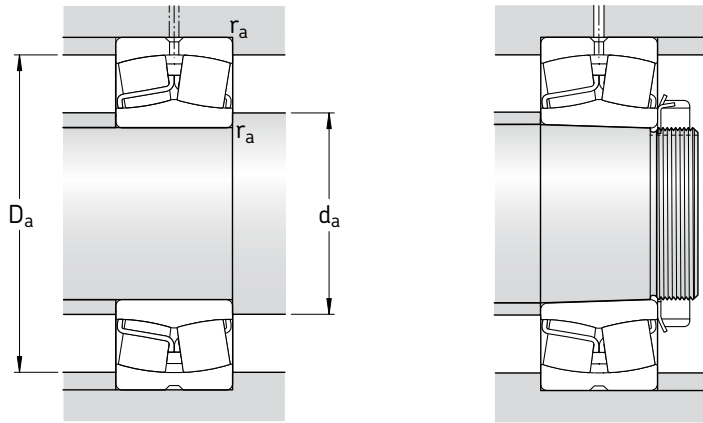

Dimensions						Abutment and fillet dimensions			Calculation factors			
d	d ₂	D ₁	b	K	r _{1,2} min	d _a min	D _a max	r _a max	e	Y ₁	Y ₂	Y ₀
mm						mm			-			
75	84,1	100	5,5	3	1,1	81	109	1	0,28	2,4	3,6	2,5
	87,8	115	5,5	3	1,5	84	121	1,5	0,22	3	4,6	2,8
	101	133	5,5	3	2,1	87	148	2	0,22	3	4,6	2,8
	92,8	135	8,3	4,5	2,1	87	148	2	0,35	1,9	2,9	1,8
80	94,7	124	5,5	3	2	91	129	2	0,22	3	4,6	2,8
	106	141	5,5	3	2,1	92	158	2	0,24	2,8	4,2	2,8
	98,3	143	8,3	4,5	2,1	92	158	2	0,35	1,9	2,9	1,8
85	101	133	5,5	3	2	96	139	2	0,22	3	4,6	2,8
	106	141	5,5	3	3	99	166	2,5	0,24	2,8	4,2	2,8
	108	154	8,3	4,5	3	99	166	2,5	0,33	2	3	2
90	106	141	5,5	3	2	101	149	2	0,24	2,8	4,2	2,8
	106	137	5,5	3	2	101	149	2	0,31	2,2	3,3	2,2
	112	150	8,3	4,5	3	104	176	2,5	0,24	2,8	4,2	2,8
	113	161	11,1	6	3	104	176	2,5	0,33	2	3	2
95	112	150	8,3	4,5	2,1	107	158	2	0,24	2,8	4,2	2,8
	118	159	8,3	4,5	3	109	186	2,5	0,24	2,8	4,2	2,8
	118	168	11,1	6	3	109	186	2,5	0,33	2	3	2
100	111	132	5,5	3	1,5	107	143	1,5	0,28	2,4	3,6	2,5
	115	144	5,5	3	2	111	154	2	0,30	2,3	3,4	2,2
	113	141	3,7	2	2	111	154	2	0,37	1,8	2,7	1,8
	118	159	8,3	4,5	2,1	112	168	2	0,24	2,8	4,2	2,8
	117	153	8,3	4,5	2,1	112	168	2	0,33	2	3	2
	118	159	8,3	4,5	3	114	201	2,5	0,24	2,8	4,2	2,8
	130	184	11,1	6	3	114	201	2,5	0,33	2	3	2
110	125	151	5,5	3	2	119	161	2	0,23	2,9	4,4	2,8
	122	149	5,5	3	2	119	161	2	0,33	2	3	2
	126	157	8,3	4,5	2	121	169	2	0,30	2,3	3,4	2,2
	123	153	5,5	3	2	121	169	2	0,37	1,8	2,7	1,8
	130	178	8,3	4,5	2,1	122	188	2	0,25	2,7	4	2,5
	130	169	8,3	4,5	2,1	122	188	2	0,33	2	3	2
143	204	13,9	7,5	3	124	226	2,5	0,33	2	3	2	

Spherical roller bearings

d 120 – 150 mm

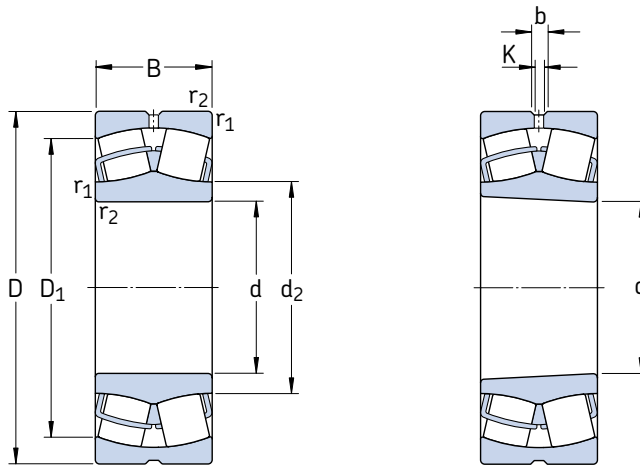

Cylindrical bore

Tapered bore

Principal dimensions			Basic load ratings dynamic static		Fatigue load limit	Speed ratings		Mass	Designations	
d	D	B	C	C ₀	P _u	Refer- ence speed	Limiting speed		Bearing with cylindrical bore	tapered bore
mm			kN		kN	r/min		kg	–	
120	180	46	355	510	53	3 200	4 000	4,20	* 23024 CC/W33	* 23024 CCK/W33
	180	60	430	670	68	2 400	3 400	5,45	* 24024 CC/W33	* 24024 CCK30/W33
	200	62	510	695	71	2 600	3 400	8,00	* 23124 CC/W33	* 23124 CCK/W33
	200	80	655	950	95	1 900	2 600	10,3	* 24124 CC/W33	* 24124 CCK30/W33
	215	58	630	765	73,5	2 800	3 800	8,70	* 22224 E	* 22224 EK
	215	76	695	930	93	2 000	2 800	12,0	* 23224 CC/W33	* 23224 CCK/W33
	260	86	965	1 120	100	2 000	2 600	23,0	* 22324 CC/W33	* 22324 CCK/W33
130	200	52	430	610	62	2 800	3 600	6,00	* 23026 CC/W33	* 23026 CCK/W33
	200	69	540	815	81,5	2 000	3 000	8,05	* 24026 CC/W33	* 24026 CCK30/W33
	210	64	560	780	78	2 400	3 200	8,80	* 23126 CC/W33	* 23126 CCK/W33
	210	80	680	1 000	100	1 800	2 400	11,0	* 24126 CC/W33	* 24126 CCK30/W33
	230	64	735	930	88	2 600	3 600	11,0	* 22226 E	* 22226 EK
	230	80	780	1 060	104	1 900	2 600	14,5	* 23226 CC/W33	* 23226 CCK/W33
	280	93	1 120	1 320	114	1 800	2 400	29,0	* 22326 CC/W33	* 22326 CCK/W33
140	210	53	465	680	68	2 600	3 400	6,55	* 23028 CC/W33	* 23028 CCK/W33
	210	69	570	900	88	2 000	2 800	8,55	* 24028 CC/W33	* 24028 CCK30/W33
	225	68	630	900	88	2 200	2 800	10,5	* 23128 CC/W33	* 23128 CCK/W33
	225	85	765	1 160	112	1 700	2 400	13,5	* 24128 CC/W33	* 24128 CCK30/W33
	250	68	710	900	86,5	2 400	3 200	14,0	* 22228 CC/W33	* 22228 CCK/W33
	250	88	915	1 250	120	1 700	2 400	19,0	* 23228 CC/W33	* 23228 CCK/W33
	300	102	1 290	1 560	132	1 700	2 200	36,5	* 22328 CC/W33	* 22328 CCK/W33
150	225	56	510	750	73,5	2 400	3 200	7,95	* 23030 CC/W33	* 23030 CCK/W33
	225	75	655	1 040	100	1 800	2 600	10,5	* 24030 CC/W33	* 24030 CCK30/W33
	250	80	830	1 200	114	2 000	2 600	16,0	* 23130 CC/W33	* 23130 CCK/W33
	250	100	1 020	1 530	146	1 500	2 200	20,0	* 24130 CC/W33	* 24130 CCK30/W33
	270	73	850	1 080	102	2 200	3 000	18,0	* 22230 CC/W33	* 22230 CCK/W33
	270	96	1 080	1 460	137	1 600	2 200	24,5	* 23230 CC/W33	* 23230 CCK/W33
	320	108	1 460	1 760	146	1 600	2 000	43,5	* 22330 CC/W33	* 22330 CCK/W33

* SKF Explorer bearing

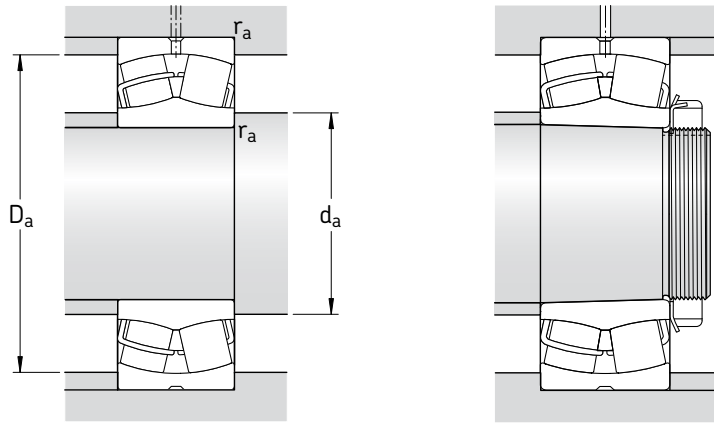

Dimensions						Abutment and fillet dimensions			Calculation factors			
d	\tilde{d}_2	\tilde{D}_1	b	K	$r_{1,2}$ min	d_a min	D_a max	r_a max	e	Y_1	Y_2	Y_0
mm						mm			-			
120	135	163	5,5	3	2	129	171	2	0,22	3	4,6	2,8
	132	159	5,5	3	2	129	171	2	0,30	2,3	3,4	2,2
	139	174	8,3	4,5	2	131	189	2	0,28	2,4	3,6	2,5
	135	168	5,5	3	2	131	189	2	0,37	1,8	2,7	1,8
	141	189	11,1	6	2,1	132	203	2	0,26	2,6	3,9	2,5
	141	182	8,3	4,5	2,1	132	203	2	0,35	1,9	2,9	1,8
	152	216	13,9	7,5	3	134	246	2,5	0,35	1,9	2,9	1,8
	148	180	8,3	4,5	2	139	191	2	0,23	2,9	4,4	2,8
	145	175	5,5	3	2	139	191	2	0,31	2,2	3,3	2,2
	148	184	8,3	4,5	2	141	199	2	0,28	2,4	3,6	2,5
146	180	5,5	3	2	141	199	2	0,35	1,9	2,9	1,8	
152	201	11,1	6	3	144	216	2,5	0,27	2,5	3,7	2,5	
151	196	8,3	4,5	3	144	216	2,5	0,33	2	3	2	
164	233	16,7	9	4	147	263	3	0,35	1,9	2,9	1,8	
140	158	190	8,3	4,5	2	149	201	2	0,22	3	4,6	2,8
	155	185	5,5	3	2	149	201	2	0,30	2,3	3,4	2,2
	159	197	8,3	4,5	2,1	152	213	2	0,28	2,4	3,6	2,5
	156	193	8,3	4,5	2,1	152	213	2	0,35	1,9	2,9	1,8
	166	216	11,1	6	3	154	236	2,5	0,26	2,6	3,9	2,5
	165	212	11,1	6	3	154	236	2,5	0,33	2	3	2
	175	247	16,7	9	4	157	283	3	0,35	1,9	2,9	1,8
	169	203	8,3	4,5	2,1	161	214	2	0,22	3	4,6	2,8
	165	197	5,5	3	2,1	161	214	2	0,30	2,3	3,4	2,2
	172	216	11,1	6	2,1	162	238	2	0,30	2,3	3,4	2,2
169	211	8,3	4,5	2,1	162	238	2	0,37	1,8	2,7	1,8	
178	234	13,9	7,5	3	164	256	2,5	0,26	2,6	3,9	2,5	
175	228	11,1	6	3	164	256	2,5	0,35	1,9	2,9	1,8	
188	266	16,7	9	4	167	303	3	0,35	1,9	2,9	1,8	

Spherical roller bearings

d 160 – 190 mm

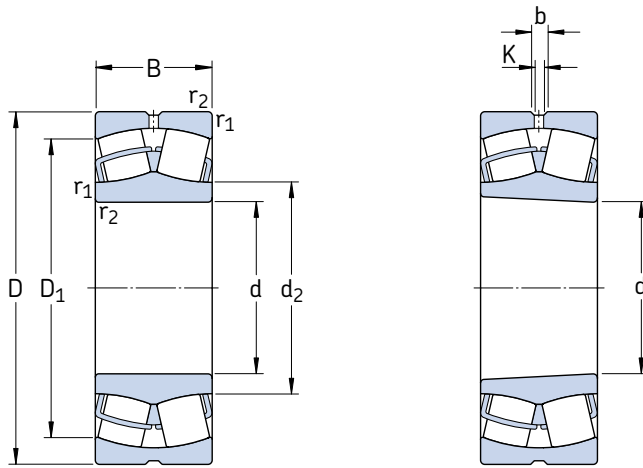

Cylindrical bore

Tapered bore

Principal dimensions			Basic load ratings dynamic static		Fatigue load limit	Speed ratings		Mass	Designations	
d	D	B	C	C ₀	P _u	Reference speed	Limiting speed		Bearing with cylindrical bore	tapered bore
mm			kN		kN	r/min		kg	–	
160	240	60	585	880	83	2 400	3 000	9,70	* 23032 CC/W33	* 23032 CCK/W33
	240	80	750	1 200	114	1 700	2 400	13,0	* 24032 CC/W33	* 24032 CCK30/W33
	270	86	980	1 370	129	1 900	2 400	20,5	* 23132 CC/W33	* 23132 CCK/W33
	270	109	1 180	1 760	163	1 400	1 900	25,0	* 24132 CC/W33	* 24132 CCK30/W33
	290	80	1 000	1 290	118	2 000	2 800	22,5	* 22232 CC/W33	* 22232 CCK/W33
	290	104	1 220	1 660	153	1 500	2 200	31,0	* 23232 CC/W33	* 23232 CCK/W33
	340	114	1 600	1 960	160	1 500	1 900	52,0	* 22332 CC/W33	* 22332 CCK/W33
170	260	67	710	1 060	100	2 200	2 800	13,0	* 23034 CC/W33	* 23034 CCK/W33
	260	90	930	1 460	137	1 600	2 400	17,5	* 24034 CC/W33	* 24034 CCK30/W33
	280	88	1 040	1 500	137	1 800	2 400	22,0	* 23134 CC/W33	* 23134 CCK/W33
	280	109	1 220	1 860	170	1 300	1 900	27,5	* 24134 CC/W33	* 24134 CCK30/W33
	310	86	1 120	1 460	132	1 900	2 600	28,5	* 22234 CC/W33	* 22234 CCK/W33
	310	110	1 400	1 930	173	1 400	2 000	37,5	* 23234 CC/W33	* 23234 CCK/W33
	360	120	1 760	2 160	176	1 400	1 800	61,0	* 22334 CC/W33	* 22334 CCK/W33
180	250	52	431	830	76,5	2 200	2 800	7,90	23936 CC/W33	23936 CCK/W33
	280	74	830	1 250	114	2 000	2 600	17,0	* 23036 CC/W33	* 23036 CCK/W33
	280	100	1 080	1 730	156	1 500	2 200	23,0	* 24036 CC/W33	* 24036 CCK30/W33
	300	96	1 200	1 760	160	1 700	2 200	28,0	* 23136 CC/W33	* 23136 CCK/W33
	300	118	1 400	2 160	196	1 300	1 700	34,5	* 24136 CC/W33	* 24136 CCK30/W33
		320	86	1 180	1 560	140	1 800	2 600	29,5	* 22236 CC/W33
	320	112	1 500	2 120	186	1 300	1 900	39,5	* 23236 CC/W33	* 23236 CCK/W33
	380	126	2 000	2 450	193	1 300	1 700	71,5	* 22336 CC/W33	* 22336 CCK/W33
190	260	52	414	800	76,5	2 200	2 600	8,30	23938 CC/W33	23938 CCK/W33
	290	75	865	1 340	122	1 900	2 400	18,0	* 23038 CC/W33	* 23038 CCK/W33
	290	100	1 120	1 800	163	1 400	2 000	24,5	* 24038 CC/W33	* 24038 CCK30/W33
	320	104	1 370	2 080	183	1 500	2 000	35,0	* 23138 CC/W33	* 23138 CCK/W33
	320	128	1 600	2 500	212	1 200	1 600	43,0	* 24138 CC/W33	* 24138 CCK30/W33
		340	92	1 270	1 700	150	1 700	2 400	36,5	* 22238 CC/W33
	340	120	1 660	2 400	208	1 300	1 800	48,0	* 23238 CC/W33	* 23238 CCK/W33
	400	132	2 120	2 650	208	1 200	1 600	82,5	* 22338 CC/W33	* 22338 CCK/W33

* SKF Explorer bearing

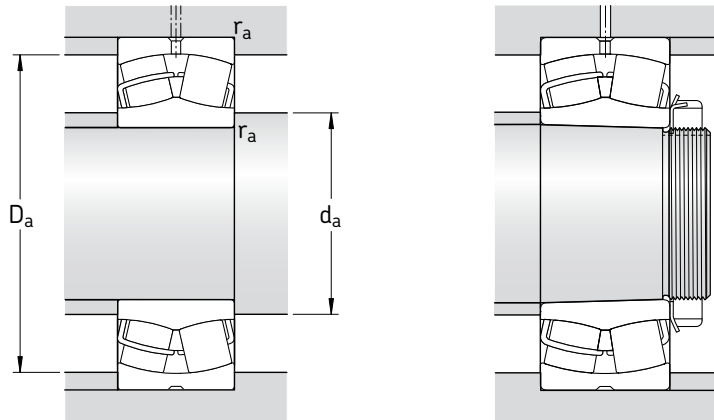

Dimensions						Abutment and fillet dimensions			Calculation factors				
d	d ₂	D ₁	b	K	r _{1,2} min	d _a min	D _a max	r _a max	e	Y ₁	Y ₂	Y ₀	
mm						mm			-				
160	180	217	11,1	6	2,1	171	229	2	0,22	3	4,6	2,8	
	176	211	8,3	4,5	2,1	171	229	2	0,30	2,3	3,4	2,2	
	184	234	13,9	7,5	2,1	172	258	2	0,30	2,3	3,4	2,2	
	181	228	8,3	4,5	2,1	172	258	2	0,40	1,7	2,5	1,6	
	191	250	13,9	7,5	3	174	276	2,5	0,26	2,6	3,9	2,5	
	188	244	13,9	7,5	3	174	276	2,5	0,35	1,9	2,9	1,8	
	200	282	16,7	9	4	177	323	3	0,35	1,9	2,9	1,8	
	191	232	11,1	6	2,1	181	249	2	0,23	2,9	4,4	2,8	
	188	226	8,3	4,5	2,1	181	249	2	0,33	2	3	2	
	195	244	13,9	7,5	2,1	182	268	2	0,30	2,3	3,4	2,2	
190	237	8,3	4,5	2,1	182	268	2	0,37	1,8	2,7	1,8		
203	267	16,7	9	4	187	293	3	0,27	2,5	3,7	2,5		
200	261	13,9	7,5	4	187	293	3	0,35	1,9	2,9	1,8		
213	300	16,7	9	4	187	343	3	0,33	2	3	2		
180	199	231	5,5	3	2	189	241	2	0,18	3,8	5,6	3,6	
	204	249	13,9	7,5	2,1	191	269	2	0,24	2,8	4,2	2,8	
	201	243	8,3	4,5	2,1	191	269	2	0,33	2	3	2	
	207	259	13,9	7,5	3	194	286	2,5	0,30	2,3	3,4	2,2	
	203	253	11,1	6	3	194	286	2,5	0,37	1,8	2,7	1,8	
	213	278	16,7	9	4	197	303	3	0,26	2,6	3,9	2,5	
	211	271	13,9	7,5	4	197	303	3	0,35	1,9	2,9	1,8	
	224	317	22,3	12	4	197	363	3	0,35	1,9	2,9	1,8	
	190	209	240	5,5	3	2	199	251	2	0,16	4,2	6,3	4
		216	261	13,9	7,5	2,1	201	279	2	0,23	2,9	4,4	2,8
210		253	8,3	4,5	2,1	201	279	2	0,31	2,2	3,3	2,2	
220		275	13,9	7,5	3	204	306	2,5	0,31	2,2	3,3	2,2	
215		268	11,1	6	3	204	306	2,5	0,40	1,7	2,5	1,6	
225		294	16,7	9	4	207	323	3	0,26	2,6	3,9	2,5	
222		287	16,7	9	4	207	323	3	0,35	1,9	2,9	1,8	
236		333	22,3	12	5	210	380	4	0,35	1,9	2,9	1,8	

Spherical roller bearings

d 200 – 260 mm

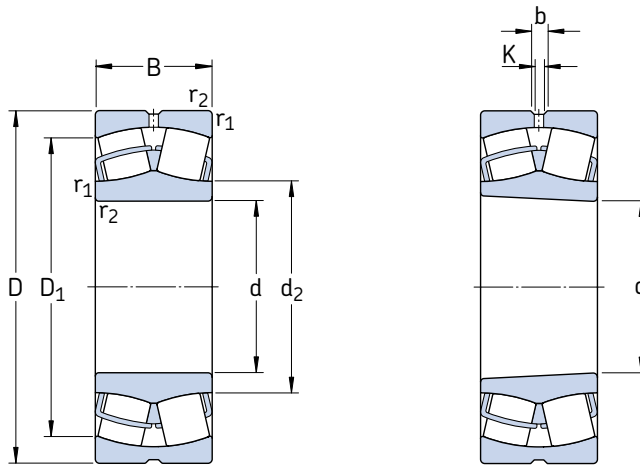

Cylindrical bore

Tapered bore

Principal dimensions			Basic load ratings dynamic static		Fatigue load limit	Speed ratings		Mass	Designations		
d	D	B	C	C ₀	P _u	Refer- ence speed	Limiting speed		Bearing with cylindrical bore	tapered bore	
mm			kN		kN	r/min		kg	–		
200	280	60	546	1 040	93	2 000	2 400	11,5	23940 CC/W33	23940 CCK/W33	
	310	82	1 000	1 530	137	1 800	2 200	23,3	* 23040 CC/W33	* 23040 CCK/W33	
	310	109	1 290	2 120	186	1 300	1 900	31,0	* 24040 CC/W33	* 24040 CCK30/W33	
	340	112	1 600	2 360	204	1 500	1 900	43,0	* 23140 CC/W33	* 23140 CCK/W33	
	340	140	1 800	2 800	232	1 100	1 500	53,5	* 24140 CC/W33	* 24140 CCK30/W33	
	360	98	1 460	1 930	166	1 600	2 200	43,5	* 22240 CC/W33	* 22240 CCK/W33	
	360	128	1 860	2 700	228	1 200	1 700	58,0	* 23240 CC/W33	* 23240 CCK/W33	
	420	138	2 320	2 900	224	1 200	1 500	95,0	* 22340 CC/W33	* 22340 CCK/W33	
	220	300	60	546	1 080	93	1 900	2 200	12,5	23944 CC/W33	23944 CCK/W33
		340	90	1 220	1 860	163	1 600	2 000	30,5	* 23044 CC/W33	* 23044 CCK/W33
340		118	1 560	2 600	212	1 200	1 700	40,0	* 24044 CC/W33	* 24044 CCK30/W33	
370		120	1 800	2 750	232	1 300	1 700	53,5	* 23144 CC/W33	* 23144 CCK/W33	
370		150	2 120	3 350	285	1 000	1 400	67,0	* 24144 CC/W33	* 24144 CCK30/W33	
400		108	1 760	2 360	196	1 500	2 000	60,5	* 22244 CC/W33	* 22244 CCK/W33	
400		144	2 360	3 450	285	1 100	1 500	81,5	* 23244 CC/W33	* 23244 CCK/W33	
460		145	2 700	3 450	260	1 000	1 400	120	* 22344 CC/W33	* 22344 CCK/W33	
240		320	60	564	1 160	98	1 700	2 000	13,5	23948 CC/W33	23948 CCK/W33
		360	92	1 290	2 080	176	1 500	1 900	33,5	* 23048 CC/W33	* 23048 CCK/W33
	360	118	1 600	2 700	228	1 100	1 600	43,0	* 24048 CC/W33	* 24048 CCK30/W33	
	400	128	2 080	3 200	255	1 200	1 600	66,5	* 23148 CC/W33	* 23148 CCK/W33	
	400	160	2 400	3 900	320	900	1 300	83,0	* 24148 CC/W33	* 24148 CCK30/W33	
	440	120	2 200	3 000	245	1 300	1 800	83,0	* 22248 CC/W33	* 22248 CCK/W33	
	440	160	2 900	4 300	345	950	1 300	110	* 23248 CC/W33	* 23248 CCK/W33	
	500	155	3 100	4 000	290	950	1 300	155	* 22348 CC/W33	* 22348 CCK/W33	
	260	360	75	880	1 800	156	1 500	1 900	23,5	23952 CC/W33	23952 CCK/W33
		400	104	1 600	2 550	212	1 300	1 700	48,5	* 23052 CC/W33	* 23052 CCK/W33
400		140	2 040	3 450	285	1 000	1 400	65,5	* 24052 CC/W33	* 24052 CCK30/W33	
440		144	2 550	3 900	290	1 100	1 400	90,5	* 23152 CC/W33	* 23152 CCK/W33	
440		180	3 000	4 800	380	850	1 200	110	* 24152 CC/W33	* 24152 CCK30/W33	
480		130	2 650	3 550	285	1 200	1 600	110	* 22252 CC/W33	* 22252 CCK/W33	
480		174	3 250	4 750	360	850	1 200	140	* 23252 CC/W33	* 23252 CCK/W33	
540		165	3 550	4 550	325	850	1 100	190	* 22352 CC/W33	* 22352 CCK/W33	

* SKF Explorer bearing

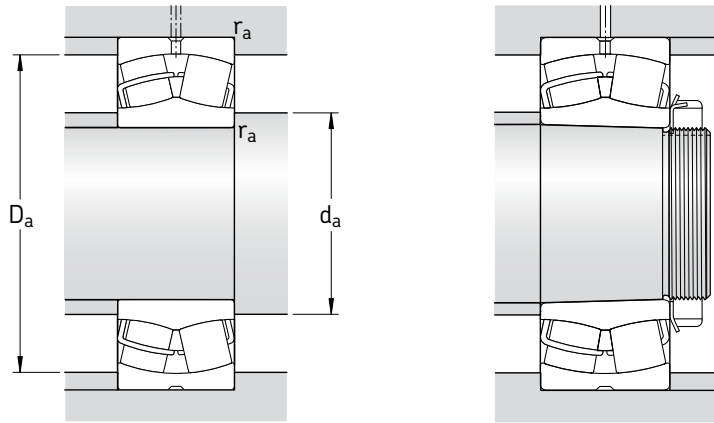

Dimensions						Abutment and fillet dimensions			Calculation factors			
d	d ₂	D ₁	b	K	r _{1,2} min	d _a min	D _a max	r _a max	e	Y ₁	Y ₂	Y ₀
mm						mm			-			
200	222	258	8,3	4,5	2,1	211	269	2	0,19	3,6	5,3	3,6
	228	278	13,9	7,5	2,1	211	299	2	0,24	2,8	4,2	2,8
	223	268	11,1	6	2,1	211	299	2	0,33	2	3	2
	231	293	16,7	9	3	214	326	2,5	0,31	2,2	3,3	2,2
	226	284	11,1	6	3	214	326	2,5	0,40	1,7	2,5	1,6
	238	313	16,7	9	4	217	343	3	0,26	2,6	3,9	2,5
	235	304	16,7	9	4	217	343	3	0,35	1,9	2,9	1,8
	248	351	22,3	12	5	220	400	4	0,33	2	3	2
	220	241	278	8,3	4,5	2,1	231	289	2	0,16	4,2	6,3
250		306	13,9	7,5	3	233	327	2,5	0,24	2,8	4,2	2,8
244		295	11,1	6	3	233	327	2,5	0,33	2	3	2
255		320	16,7	9	4	237	353	3	0,30	2,3	3,4	2,2
248		310	11,1	6	4	237	353	3	0,40	1,7	2,5	1,6
263		346	16,7	9	4	237	383	3	0,27	2,5	3,7	2,5
259		338	16,7	9	4	237	383	3	0,35	1,9	2,9	1,8
279		389	22,3	12	5	240	440	4	0,31	2,2	3,3	2,2
240		261	298	8,3	4,5	2,1	251	309	2	0,15	4,5	6,7
	271	326	13,9	7,5	3	253	347	2,5	0,23	2,9	4,4	2,8
	265	316	11,1	6	3	253	347	2,5	0,30	2,3	3,4	2,2
	277	348	16,7	9	4	257	383	3	0,30	2,3	3,4	2,2
	271	336	11,1	6	4	257	383	3	0,40	1,7	2,5	1,6
	290	383	22,3	12	4	257	423	3	0,27	2,5	3,7	2,5
	286	374	22,3	12	4	257	423	3	0,35	1,9	2,9	1,8
	303	423	22,3	12	5	260	480	4	0,31	2,2	3,3	2,2
	260	287	331	8,3	4,5	2,1	271	349	2	0,18	3,8	5,6
295		360	16,7	9	4	275	385	3	0,23	2,9	4,4	2,8
289		347	11,1	6	4	275	385	3	0,33	2	3	2
301		380	16,7	9	4	277	423	3	0,31	2,2	3,3	2,2
293		368	13,9	7,5	4	277	423	3	0,40	1,7	2,5	1,6
311		421	22,3	12	5	280	460	4	0,27	2,5	3,7	2,5
312		408	22,3	12	5	280	460	4	0,35	1,9	2,9	1,8
328		458	22,3	12	6	286	514	5	0,31	2,2	3,3	2,2

Spherical roller bearings

d 280 – 340 mm

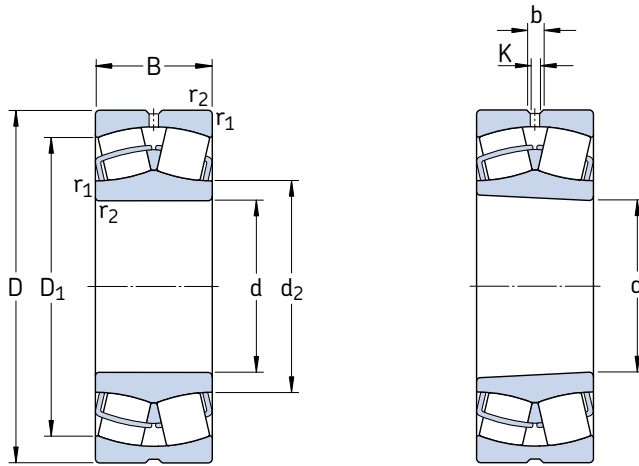

Cylindrical bore

Tapered bore

Principal dimensions			Basic load ratings dynamic static		Fatigue load limit P_u	Speed ratings Reference speed Limiting speed		Mass	Designations Bearing with cylindrical bore	tapered bore	
d	D	B	C	C_0				kg			
mm			kN		kN	r/min			–		
280	380	75	845	1 760	143	1 400	1 700	25,0	23956 CC/W33	23956 CCK/W33	
	420	106	1 730	2 850	224	1 300	1 600	52,5	* 23056 CC/W33	* 23056 CCK/W33	
	420	140	2 160	3 800	285	950	1 400	69,5	* 24056 CC/W33	* 24056 CCK30/W33	
	460	146	2 650	4 250	335	1 000	1 300	97,0	* 23156 CC/W33	* 23156 CCK/W33	
	460	180	3 100	5 100	415	800	1 100	120	* 24156 CC/W33	* 24156 CCK30/W33	
	500	130	2 700	3 750	300	1 100	1 500	115	* 22256 CC/W33	* 22256 CCK/W33	
	500	176	3 250	4 900	365	800	1 100	150	* 23256 CC/W33	* 23256 CCK/W33	
	580	175	4 000	5 200	365	800	1 100	235	* 22356 CC/W33	* 22356 CCK/W33	
	300	380	60	656	1 600	137	1 400	1 700	16,5	23860 CAMA	23860 CAKMA
		420	90	1 200	2 500	200	1 300	1 600	39,5	23960 CC/W33	23960 CCK/W33
460		118	2 120	3 450	265	1 200	1 500	71,5	* 23060 CC/W33	* 23060 CCK/W33	
460		160	2 700	4 750	355	850	1 200	97,0	* 24060 CC/W33	* 24060 CCK30/W33	
500		160	3 200	5 100	380	950	1 200	125	* 23160 CC/W33	* 23160 CCK/W33	
500		200	3 750	6 300	465	700	1 000	160	* 24160 CC/W33	* 24160 CCK30/W33	
540		140	3 150	4 250	325	1 000	1 400	145	* 22260 CC/W33	* 22260 CCK/W33	
540		192	3 900	5 850	425	750	1 000	190	* 23260 CC/W33	* 23260 CCK/W33	
320		440	90	1 430	2 700	212	1 400	1 500	42,0	* 23964 CC/W33	* 23964 CCK/W33
		480	121	2 240	3 800	285	1 100	1 400	78,0	* 23064 CC/W33	* 23064 CCK/W33
	480	160	2 850	5 100	400	800	1 200	100	* 24064 CC/W33	* 24064 CCK30/W33	
	540	176	3 750	6 000	440	850	1 100	165	* 23164 CC/W33	* 23164 CCK/W33	
	540	218	4 250	7 100	510	670	900	210	* 24164 CC/W33	* 24164 CCK30/W33	
	580	150	3 600	4 900	375	950	1 300	175	* 22264 CC/W33	* 22264 CCK/W33	
	580	208	4 400	6 700	480	700	950	240	* 23264 CC/W33	* 23264 CCK/W33	
	340	460	90	1 460	2 800	216	1 300	1 400	45,5	* 23968 CC/W33	* 23968 CCK/W33
		520	133	2 700	4 550	335	1 000	1 300	105	* 23068 CC/W33	* 23068 CCK/W33
		520	180	3 450	6 200	475	750	1 100	140	* 24068 CC/W33	* 24068 CCK30/W33
580		190	4 250	6 800	480	800	1 000	210	* 23168 CC/W33	* 23168 CCK/W33	
580		243	5 300	8 650	630	600	850	280	* 24168 ECCJ/W33	* 24168 ECCK30J/W33	
620		224	5 100	7 800	550	560	800	295	* 23268 CA/W33	* 23268 CAK/W33	

* SKF Explorer bearing

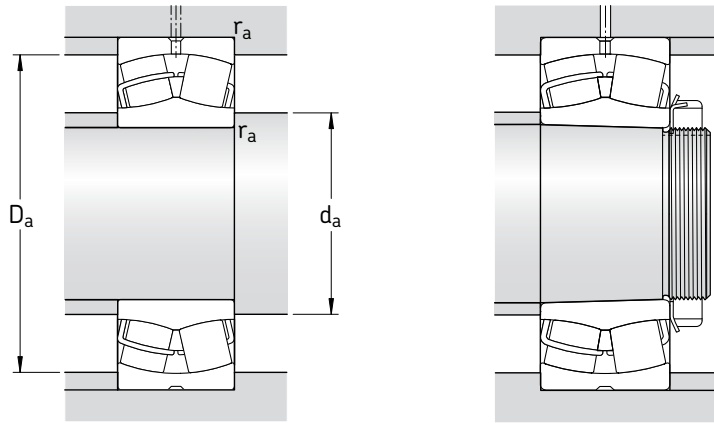

Dimensions						Abutment and fillet dimensions			Calculation factors				
d	d ₂	D ₁	b	K	r _{1,2} min	d _a min	D _a max	r _a max	e	Y ₁	Y ₂	Y ₀	
mm						mm			-				
280	308	352	11,1	6	2,1	291	369	2	0,16	4,2	6,3	4	
	315	380	16,7	9	4	295	405	3	0,23	2,9	4,4	2,8	
	309	368	11,1	6	4	295	405	3	0,31	2,2	3,3	2,2	
	321	401	16,7	9	5	300	440	4	0,30	2,3	3,4	2,2	
	314	390	13,9	7,5	5	300	440	4	0,40	1,7	2,5	1,6	
	333	441	22,3	12	5	300	480	4	0,26	2,6	3,9	2,5	
	332	429	22,3	12	5	300	480	4	0,35	1,9	2,9	1,8	
	354	492	22,3	12	6	306	554	5	0,30	2,3	3,4	2,2	
	300	329	358	-	-	2,1	311	369	2	0,13	5,2	7,7	5
333		385	11,1	6	3	313	407	2,5	0,19	3,6	5,3	3,6	
340		414	16,7	9	4	315	445	3	0,23	2,9	4,4	2,8	
331		400	13,9	7,5	4	315	445	3	0,33	2	3	2	
345		434	16,7	9	5	320	480	4	0,30	2,3	3,4	2,2	
338		422	13,9	7,5	5	320	480	4	0,40	1,7	2,5	1,6	
354		477	22,3	12	5	320	520	4	0,26	2,6	3,9	2,5	
356		461	22,3	12	5	320	520	4	0,35	1,9	2,9	1,8	
320		354	406	11,1	6	3	333	427	2,5	0,17	4	5,9	4
	360	434	16,7	9	4	335	465	3	0,23	2,9	4,4	2,8	
	354	423	13,9	7,5	4	335	465	3	0,31	2,2	3,3	2,2	
	370	465	22,3	12	5	340	520	4	0,31	2,2	3,3	2,2	
	364	455	16,7	9	5	340	520	4	0,40	1,7	2,5	1,6	
	379	513	22,3	12	5	340	560	4	0,26	2,6	3,9	2,5	
	382	493	22,3	12	5	340	560	4	0,35	1,9	2,9	1,8	
	340	373	426	11,1	6	3	353	447	2,5	0,17	4	5,9	4
		385	468	22,3	12	5	358	502	4	0,24	2,8	4,2	2,8
377		453	16,7	9	5	358	502	4	0,33	2	3	2	
394		498	22,3	12	5	360	560	4	0,31	2,2	3,3	2,2	
383		491	16,7	9	5	360	560	4	0,40	1,7	2,5	1,6	
426		528	22,3	12	6	366	594	5	0,35	1,9	2,9	1,8	

Spherical roller bearings

d 360 – 420 mm

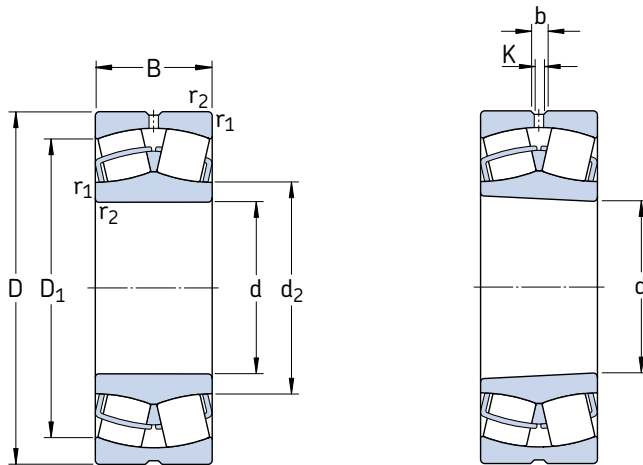

Cylindrical bore

Tapered bore

Principal dimensions			Basic load ratings		Fatigue load limit P_u	Speed ratings		Mass	Designations	
d	D	B	dynamic C	static C_0		Refer- ence speed	Limiting speed		Bearing with cylindrical bore	tapered bore
mm			kN		kN	r/min		kg	–	
360	480	90	1 400	2 750	220	1 200	1 300	46,0	* 23972 CC/W33	* 23972 CCK/W33
	540	134	2 750	4 800	345	950	1 200	110	* 23072 CC/W33	* 23072 CCK/W33
	540	180	3 550	6 550	490	700	1 000	145	* 24072 CC/W33	* 24072 CCK30/W33
	600	192	4 300	6 950	490	750	1 000	220	* 23172 CC/W33	* 23172 CCK/W33
	600	243	5 600	9 300	670	560	800	280	* 24172 ECCJ/W33	* 24172 ECC30J/W33
	650	170	4 300	6 200	440	630	850	255	* 22272 CA/W33	* 22272 CAK/W33
	650	232	5 400	8 300	570	530	750	335	* 23272 CA/W33	* 23272 CAK/W33
380	520	106	1 960	3 800	285	1 100	1 200	69,0	* 23976 CC/W33	* 23976 CCK/W33
	560	135	2 900	5 000	360	900	1 200	115	* 23076 CC/W33	* 23076 CCK/W33
	560	180	3 600	6 800	480	670	950	150	* 24076 CC/W33	* 24076 CCK30/W33
	620	194	4 400	7 100	500	560	1 000	230	* 23176 CA/W33	* 23176 CAK/W33
	620	243	5 700	9 800	710	480	850	300	* 24176 ECA/W33	* 24176 ECAK30/W33
	680	240	5 850	9 150	620	500	750	375	* 23276 CA/W33	* 23276 CAK/W33
400	540	106	2 000	3 900	290	1 100	1 200	71,0	* 23980 CC/W33	* 23980 CCK/W33
	600	148	3 250	5 700	400	850	1 100	150	* 23080 CC/W33	* 23080 CCK/W33
	600	200	4 300	8 000	560	630	900	205	* 24080 ECCJ/W33	* 24080 ECC30J/W33
	650	200	4 650	7 650	530	530	950	265	* 23180 CA/W33	* 23180 CAK/W33
	650	250	6 200	10 600	735	430	800	340	* 24180 ECA/W33	* 24180 ECAK30/W33
	720	256	6 550	10 400	680	480	670	450	* 23280 CA/W33	* 23280 CAK/W33
	820	243	7 500	10 400	670	430	750	650	* 22380 CA/W33	* 22380 CAK/W33
420	560	106	2 040	4 150	300	1 000	1 100	74,5	* 23984 CC/W33	* 23984 CCK/W33
	620	150	3 400	6 000	415	600	1 100	155	* 23084 CA/W33	* 23084 CCK/W33
	620	200	4 400	8 300	585	530	900	210	* 24084 ECA/W33	* 24084 ECAK30/W33
	700	224	5 600	9 300	620	480	900	350	* 23184 CJ/W33	* 23184 CKJ/W33
	700	280	7 350	12 600	850	400	700	445	* 24184 ECA/W33	* 24184 ECAK30/W33
	760	272	7 350	11 600	765	450	630	535	* 23284 CA/W33	* 23284 CAK/W33

* SKF Explorer bearing

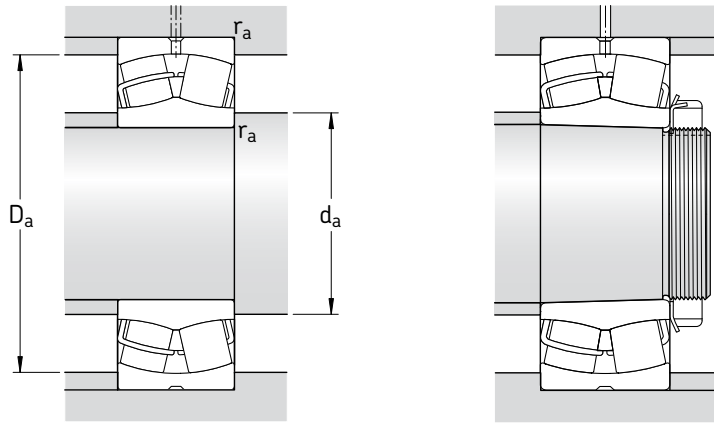

Dimensions						Abutment and fillet dimensions			Calculation factors			
d	d ₂	D ₁	b	K	r _{1,2} min	d _a min	D _a max	r _a max	e	Y ₁	Y ₂	Y ₀
mm						mm			-			
360	394	447	11,1	6	3	373	467	2,5	0,15	4,5	6,7	4,5
	404	483	22,3	12	5	378	522	4	0,23	2,9	4,4	2,8
	397	474	16,7	9	5	378	522	4	0,31	2,2	3,3	2,2
360	418	524	22,3	12	5	380	580	4	0,30	2,3	3,4	2,2
	404	511	16,7	9	5	380	580	4	0,40	1,7	2,5	1,6
	453	568	22,3	12	6	386	624	5	0,26	2,6	3,9	2,5
	447	552	22,3	12	6	386	624	5	0,35	1,9	2,9	1,8
	380	419	481	13,9	7,5	4	395	505	3	0,17	4	5,9
426		509	22,3	12	5	398	542	4	0,22	3	4,6	2,8
419		497	16,7	9	5	398	542	4	0,30	2,3	3,4	2,2
380	452	541	22,3	12	5	400	600	4	0,30	2,3	3,4	2,2
	442	532	16,7	9	5	400	600	4	0,37	1,8	2,7	1,8
	471	581	22,3	12	6	406	654	5	0,35	1,9	2,9	1,8
400	439	500	13,9	7,5	4	415	525	3	0,16	4,2	6,3	4
	450	543	22,3	12	5	418	582	4	0,23	2,9	4,4	2,8
	442	527	22,3	12	5	418	582	4	0,30	2,3	3,4	2,2
400	474	566	22,3	12	6	426	624	5	0,28	2,4	3,6	2,5
	465	559	22,3	12	6	426	624	5	0,37	1,8	2,7	1,8
	499	615	22,3	12	6	426	694	5	0,35	1,9	2,9	1,8
	534	697	22,3	12	7,5	432	788	6	0,30	2,3	3,4	2,2
	420	459	520	16,7	9	4	435	545	3	0,16	4,2	6,3
485		563	22,3	12	5	438	602	4	0,22	3	4,6	2,8
476		547	22,3	12	5	438	602	4	0,30	2,3	3,4	2,2
420	483	607	22,3	12	6	446	674	5	0,30	2,3	3,4	2,2
	494	597	22,3	12	6	446	674	5	0,40	1,7	2,5	1,6
	525	649	22,3	12	7,5	452	728	6	0,35	1,9	2,9	1,8

Spherical roller bearings

d 440 – 500 mm

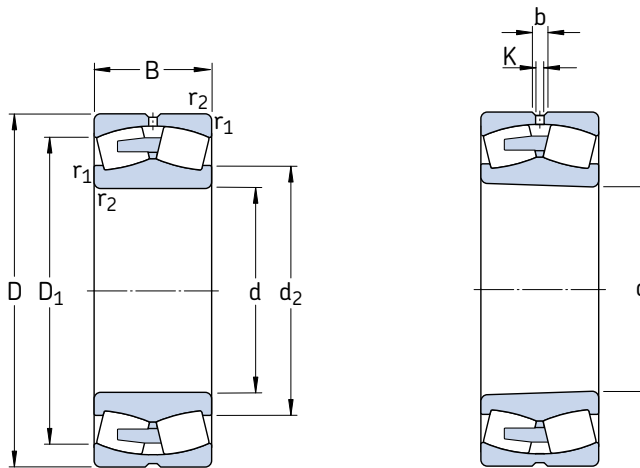

Cylindrical bore

Tapered bore

Principal dimensions			Basic load ratings		Fatigue load limit P_u	Speed ratings		Mass	Designations	
d	D	B	C	C_0		Refer- ence speed	Limiting speed		Bearing with cylindrical bore	tapered bore
mm			kN		kN	r/min		kg	–	
440	600	118	2 450	4 900	345	950	1 000	99,5	* 23988 CC/W33	* 23988 CCK/W33
	650	157	3 650	6 550	450	560	1 000	180	* 23088 CA/W33	* 23088 CAK/W33
	650	212	4 800	9 150	630	500	850	245	* 24088 ECA/W33	* 24088 ECAK30/W33
	720	226	6 000	10 000	670	450	850	360	* 23188 CA/W33	* 23188 CAK/W33
	720	280	7 500	13 200	900	400	700	460	* 24188 ECA/W33	* 24188 ECAK30/W33
	790	280	7 800	12 500	800	430	600	590	* 23288 CA/W33	* 23288 CAK/W33
	790	310	9 300	15 000	950	380	530	800	* 23296 CA/W33	* 23296 CAK/W33
460	580	118	1 790	4 900	345	560	1 100	75,5	24892 CAMA/W20	24892 CAK30MA/W20
	620	118	2 500	5 000	355	600	1 000	105	* 23992 CA/W33	* 23992 CAK/W33
	680	163	3 900	6 950	465	560	950	205	* 23092 CA/W33	* 23092 CAK/W33
	680	218	5 200	10 000	670	480	800	275	* 24092 ECA/W33	* 24092 ECAK30/W33
	760	240	6 400	10 800	680	430	800	440	* 23192 CA/W33	* 23192 CAK/W33
	760	300	8 300	14 600	1 000	360	670	560	* 24192 ECA/W33	* 24192 ECAK30/W33
	830	296	8 500	13 700	880	400	560	695	* 23292 CA/W33	* 23292 CAK/W33
480	600	90	1 440	3 750	280	530	1 100	61,0	23896 CAMA/W20	23896 CAKMA/W20
	650	128	2 900	5 700	405	560	1 000	125	* 23996 CA/W33	* 23996 CAK/W33
	700	165	3 900	6 800	450	530	950	215	* 23096 CA/W33	* 23096 CAK/W33
	700	218	5 300	10 400	695	450	750	285	* 24096 ECA/W33	* 24096 ECAK30/W33
	790	248	6 950	12 000	780	400	750	485	* 23196 CA/W33	* 23196 CAK/W33
	790	308	9 000	15 600	1 040	340	630	605	* 24196 ECA/W33	* 24196 ECAK30/W33
	870	310	9 300	15 000	950	380	530	800	* 23296 CA/W33	* 23296 CAK/W33
500	620	90	1 480	4 000	290	530	1 000	62,0	238/500 CAMA/W20	238/500 CAKMA/W20
	670	128	2 900	6 000	415	530	950	130	* 239/500 CA/W33	* 239/500 CAK/W33
	720	167	4 150	7 800	510	500	900	225	* 230/500 CA/W33	* 230/500 CAK/W33
	720	218	5 500	11 000	735	430	700	295	* 240/500 ECA/W33	* 240/500 ECAK30/W33
	830	264	7 650	12 900	830	380	700	580	* 231/500 CA/W33	* 231/500 CAK/W33
	830	325	9 800	17 000	1 120	320	600	700	* 241/500 ECA/W33	* 241/500 ECAK30/W33
	920	336	10 600	17 300	1 060	360	500	985	* 232/500 CA/W33	* 232/500 CAK/W33

* SKF Explorer bearing

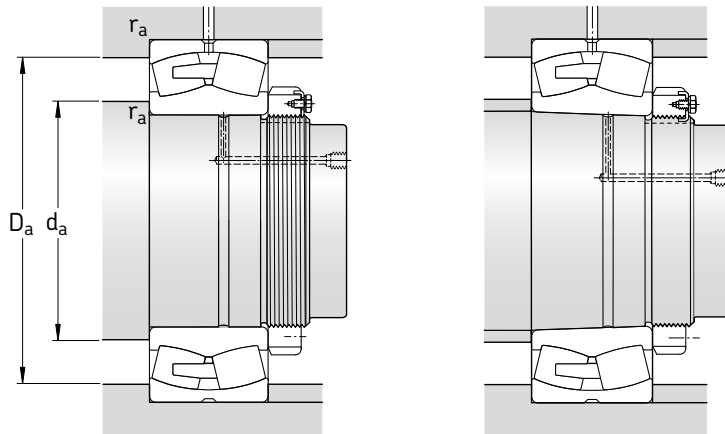

Dimensions						Abutment and fillet dimensions			Calculation factors			
d	d_2	D_1	b	K	$r_{1,2}$ min	d_a min	D_a max	r_a max	e	Y_1	Y_2	Y_0
mm						mm			-			
440	484	553	16,7	9	4	455	585	3	0,16	4,2	6,3	4
	509	590	22,3	12	6	463	627	5	0,22	3	4,6	2,8
	498	572	22,3	12	6	463	627	5	0,30	2,3	3,4	2,2
	528	632	22,3	12	6	466	694	5	0,30	2,3	3,4	2,2
	516	618	22,3	12	6	466	694	5	0,37	1,8	2,7	1,8
	547	676	22,3	12	7,5	472	758	6	0,35	1,9	2,9	1,8
460	505	541	-	6	3	473	567	2,5	0,17	4	5,9	4
	512	574	16,7	9	4	475	605	3	0,16	4,2	6,3	4
	531	617	22,3	12	6	483	657	5	0,22	3	4,6	2,8
	523	601	22,3	12	6	483	657	5	0,28	2,4	3,6	2,5
	553	666	22,3	12	7,5	492	728	6	0,30	2,3	3,4	2,2
	544	649	22,3	12	7,5	492	728	6	0,37	1,8	2,7	1,8
572	706	22,3	12	7,5	492	798	6	0,35	1,9	2,9	1,8	
480	521	566	-	7,5	3	493	587	2,5	0,13	5,2	7,7	5
	532	602	16,7	9	5	498	632	4	0,18	3,8	5,6	3,6
	547	633	22,3	12	6	503	677	5	0,21	3,2	4,8	3,2
	541	619	22,3	12	6	503	677	5	0,28	2,4	3,6	2,5
	577	692	22,3	12	7,5	512	758	6	0,30	2,3	3,4	2,2
	564	678	22,3	12	7,5	512	758	6	0,37	1,8	2,7	1,8
600	741	22,3	12	7,5	512	838	6	0,35	1,9	2,9	1,8	
500	543	587	-	7,5	3	513	607	2,5	0,12	5,6	8,4	5,6
	557	622	22,3	12	5	518	652	4	0,17	4	5,9	4
	571	658	22,3	12	6	523	697	5	0,21	3,2	4,8	3,2
	565	644	22,3	12	6	523	697	5	0,26	2,6	3,9	2,5
	603	726	22,3	12	7,5	532	798	6	0,30	2,3	3,4	2,2
	589	713	22,3	12	7,5	532	798	6	0,37	1,8	2,7	1,8
631	779	22,3	12	7,5	532	888	6	0,35	1,9	2,9	1,8	

Spherical roller bearings

d 530 – 630 mm

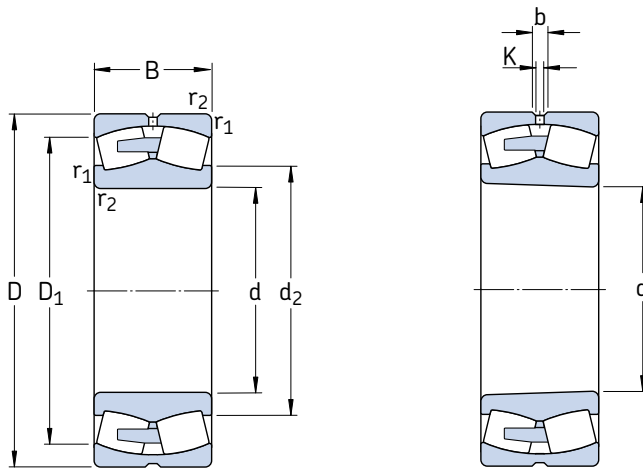

Cylindrical bore

Tapered bore

Principal dimensions			Basic load ratings		Fatigue load limit P_u	Speed ratings		Mass	Designations	
d	D	B	dynamic C	static C_0		Refer- ence speed	Limiting speed		Bearing with cylindrical bore	tapered bore
mm			kN		kN	r/min	kg	–		
530	650	118	1 840	5 300	380	480	950	86,0	248/530 CAMA/W20	248/530 CAK30MA/W20
	710	136	3 200	6 700	480	500	900	155	* 239/530 CA/W33	* 239/530 CAK/W33
	780	185	5 100	9 300	630	450	800	310	* 230/530 CA/W33	* 230/530 CAK/W33
	780	250	6 700	13 200	830	400	670	410	* 240/530 ECA/W33	* 240/530 ECAK30/W33
	870	272	8 150	14 000	915	360	670	645	* 231/530 CA/W33	* 231/530 CAK/W33
	870	335	10 600	19 000	1 220	300	560	830	* 241/530 ECA/W33	* 241/530 ECAK30/W33
	980	355	11 100	20 400	1 220	300	480	1 200	232/530 CA/W33	232/530 CAK/W33
560	750	140	3 450	7 200	510	450	850	175	* 239/560 CA/W33	* 239/560 CAK/W33
	820	195	5 600	10 200	680	430	750	355	* 230/560 CA/W33	* 230/560 CAK/W33
	820	258	7 350	14 600	960	380	630	465	* 240/560 ECA/W33	* 240/560 ECAK30/W33
	920	280	9 150	16 000	980	340	630	740	* 231/560 CA/W33	* 231/560 CAK/W33
	920	355	12 000	21 600	1 340	280	500	985	* 241/560 ECJ/W33	* 241/560 ECK30J/W33
	1 030	365	11 500	22 000	1 400	280	430	1 350	232/560 CA/W33	232/560 CAK/W33
600	800	150	3 900	8 300	585	430	750	220	* 239/600 CA/W33	* 239/600 CAK/W33
	870	200	6 000	11 400	750	400	700	405	* 230/600 CA/W33	* 230/600 CAK/W33
	870	272	8 150	17 000	1 100	340	560	520	* 240/600 ECA/W33	* 240/600 ECAK30/W33
	980	300	10 200	18 000	1 100	320	560	895	* 231/600 CA/W33	* 231/600 CAK/W33
	980	375	11 500	23 600	1 460	240	480	1 200	241/600 ECA/W33	241/600 ECAK30/W33
	1 090	388	13 100	25 500	1 560	260	400	1 600	232/600 CA/W33	232/600 CAK/W33
630	780	112	2 190	6 100	415	400	750	120	238/630 CAMA/W20	238/630 CAKMA/W20
	850	165	4 650	9 800	640	400	700	280	* 239/630 CA/W33	* 239/630 CAK/W33
	920	212	6 700	12 500	800	380	670	485	* 230/630 CA/W33	* 230/630 CAK/W33
	920	290	8 800	18 000	1 140	320	530	645	* 240/630 ECJ/W33	* 240/630 ECK30J/W33
	1 030	315	10 500	20 800	1 220	260	530	1 050	231/630 CA/W33	231/630 CAK/W33
	1 030	400	12 700	27 000	1 630	220	450	1 400	241/630 ECA/W33	241/630 ECAK30/W33

* SKF Explorer bearing

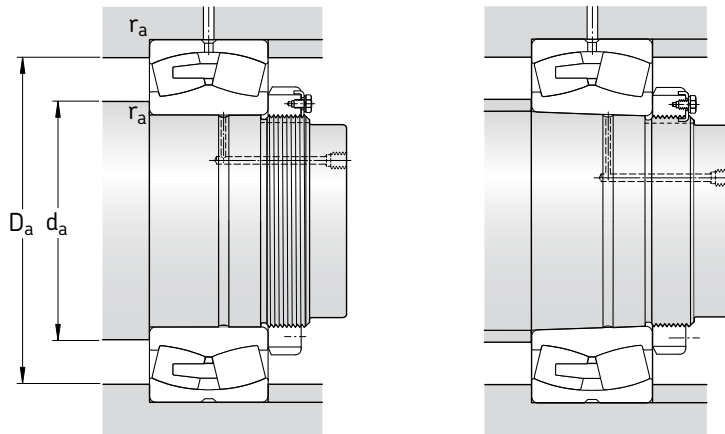

Dimensions						Abutment and fillet dimensions			Calculation factors				
d	d ₂	D ₁	b	K	r _{1,2} min	d _a min	D _a max	r _a max	e	Y ₁	Y ₂	Y ₀	
mm						mm			–				
530	573	612	–	7,5	3	543	637	2,5	0,15	4,5	6,7	4,5	
	589	661	22,3	12	5	548	692	4	0,17	4	5,9	4	
	611	710	22,3	12	6	553	757	5	0,22	3	4,6	2,8	
	600	687	22,3	12	6	553	757	5	0,28	2,4	3,6	2,5	
	636	763	22,3	12	7,5	562	838	6	0,30	2,3	3,4	2,2	
	623	748	22,3	12	7,5	562	838	6	0,37	1,8	2,7	1,8	
	668	836	22,3	12	9,5	570	940	8	0,35	1,9	2,9	1,8	
	560	625	697	22,3	12	5	578	732	4	0,16	4,2	6,3	4
		644	746	22,3	12	6	583	797	5	0,22	3	4,6	2,8
635		728	22,3	12	6	583	797	5	0,28	2,4	3,6	2,5	
673		809	22,3	12	7,5	592	888	6	0,30	2,3	3,4	2,2	
634		796	22,3	12	7,5	592	888	6	0,35	1,9	2,9	1,8	
704		878	22,3	12	9,5	600	990	8	0,35	1,9	2,9	1,8	
600	668	744	22,3	12	5	618	782	4	0,17	4	5,9	4	
	683	789	22,3	12	6	623	847	5	0,22	3	4,6	2,8	
	675	774	22,3	12	6	623	847	5	0,30	2,3	3,4	2,2	
	720	863	22,3	12	7,5	632	948	6	0,30	2,3	3,4	2,2	
	702	845	22,3	12	7,5	632	948	6	0,37	1,8	2,7	1,8	
	752	929	22,3	12	9,5	640	1 050	8	0,35	1,9	2,9	1,8	
630	681	738	–	9	4	645	765	3	0,12	5,6	8,4	5,6	
	705	787	22,3	12	6	653	827	5	0,17	4	5,9	4	
	725	839	22,3	12	7,5	658	892	6	0,21	3,2	4,8	3,2	
	697	823	22,3	12	7,5	658	892	6	0,28	2,4	3,6	2,5	
	755	918	22,3	12	7,5	662	998	6	0,30	2,3	3,4	2,2	
	738	885	22,3	12	7,5	662	998	6	0,37	1,8	2,7	1,8	

Spherical roller bearings

d 670 – 800 mm

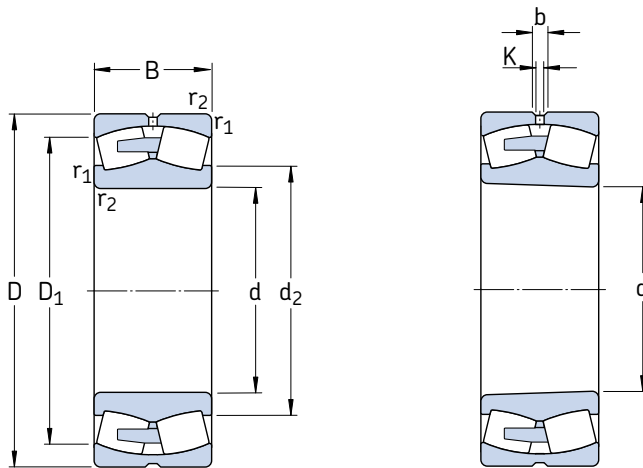

Cylindrical bore

Tapered bore

Principal dimensions			Basic load ratings		Fatigue load limit P_u	Speed ratings		Mass kg	Designations	
d	D	B	C	C_0		Refer- ence speed	Limiting speed		Bearing with cylindrical bore	tapered bore
mm			kN		kN	r/min	kg	–		
670	820	112	2 250	6 400	440	360	700	130	238/670 CAMA/W20	238/670 CAKMA/W20
	820	150	3 110	9 500	655	360	700	172	248/670 CAMA/W20	–
	900	170	5 000	10 800	695	360	670	315	* 239/670 CA/W33	* 239/670 CAK/W33
	980	230	7 650	14 600	915	340	600	600	* 230/670 CA/W33	* 230/670 CAK/W33
	980	308	10 000	20 400	1 320	300	500	790	* 240/670 ECA/W33	* 240/670 ECAK30/W33
	1 090	336	10 900	22 400	1 370	240	500	1 250	231/670 CA/W33	231/670 CAK/W33
1 090	412	13 800	29 000	1 760	200	400	1 600	241/670 ECA/W33	241/670 ECAK30/W33	
1 220	438	15 400	30 500	1 700	220	360	2 270	232/670 CA/W33	232/670 CAK/W33	
710	870	118	2 580	7 500	500	340	670	153	238/710 CAMA/W20	–
	950	180	5 600	12 000	765	340	600	365	* 239/710 CA/W33	* 239/710 CAK/W33
	950	243	6 800	15 600	930	300	500	495	* 249/710 CA/W33	* 249/710 CAK30/W33
	1 030	236	8 300	16 300	1 000	320	560	670	* 230/710 CA/W33	* 230/710 CAK/W33
	1 030	315	10 400	22 000	1 370	280	450	895	* 240/710 ECA/W33	* 240/710 ECAK30/W33
	1 150	345	12 200	26 000	1 530	240	450	1 450	231/710 CA/W33	231/710 CAK/W33
1 150	438	15 200	32 500	1 900	190	380	1 900	241/710 ECA/W33	241/710 ECAK30/W33	
1 280	450	17 600	34 500	2 000	200	320	2 610	232/710 CA/W33	232/710 CAK/W33	
750	920	128	2 930	8 500	550	320	600	180	238/750 CAMA/W20	238/750 CAKMA/W20
	1 000	185	6 000	13 200	815	320	560	420	* 239/750 CA/W33	* 239/750 CAK/W33
	1 000	250	7 650	18 000	1 100	280	480	560	* 249/750 CA/W33	* 249/750 CAK30/W33
	1 090	250	9 650	18 600	1 100	300	530	795	* 230/750 CA/W33	* 230/750 CAK/W33
	1 090	335	11 400	24 000	1 400	260	430	1 065	* 240/750 ECA/W33	* 240/750 ECAK30/W33
	1 220	365	13 800	29 000	1 660	220	430	1 700	231/750 CA/W33	231/750 CAK/W33
1 220	475	17 300	37 500	2 160	180	360	2 100	241/750 ECA/W33	241/750 ECAK30/W33	
1 360	475	18 700	36 500	2 120	190	300	3 050	232/750 CAF/W33	232/750 CAKF/W33	
800	980	180	4 140	12 900	830	300	560	300	248/800 CAMA/W20	248/800 CAK30MA/W20
	1 060	195	6 400	14 300	880	300	530	470	* 239/800 CA/W33	* 239/800 CAK/W33
	1 060	258	8 000	19 300	1 060	260	430	640	* 249/800 CA/W33	* 249/800 CAK30/W33
	1 150	258	10 000	20 000	1 160	280	480	895	* 230/800 CA/W33	* 230/800 CAK/W33
	1 150	345	12 500	27 500	1 730	240	400	1 200	* 240/800 ECA/W33	* 240/800 ECAK30/W33
	1 280	375	14 800	31 500	1 800	200	400	1 920	231/800 CA/W33	231/800 CAK/W33
1 280	475	18 400	40 500	2 320	170	320	2 300	241/800 ECA/W33	241/800 ECAK30/W33	

* SKF Explorer bearing

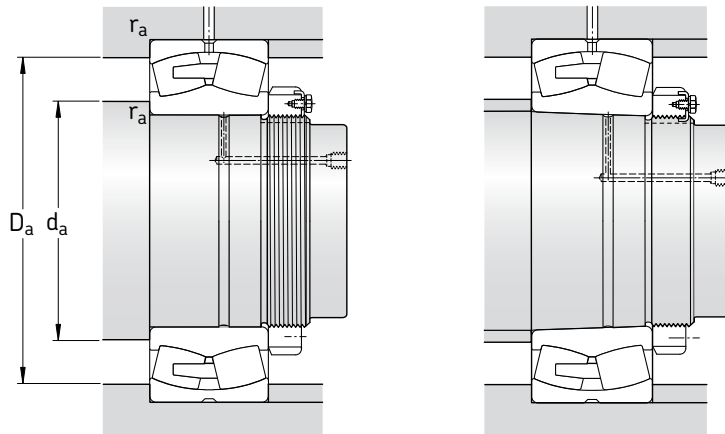

Dimensions						Abutment and fillet dimensions			Calculation factors			
d	d ₂	D ₁	b	K	r _{1,2} min	d _a min	D _a max	r _a max	e	Y ₁	Y ₂	Y ₀
mm						mm			-			
670	720	778	-	9	4	685	805	3	0,11	6,1	9,1	6,3
	718	772	-	9	4	685	805	3	0,16	4,2	6,3	4
	749	835	22,3	12	6	693	877	5	0,17	4	5,9	4
	770	892	22,3	12	7,5	698	952	6	0,21	3,2	4,8	3,2
	756	866	22,3	12	7,5	698	952	6	0,28	2,4	3,6	2,5
	802	959	22,3	12	7,5	702	1 058	6	0,30	2,3	3,4	2,2
	782	942	22,3	12	7,5	702	1 058	6	0,37	1,8	2,7	1,8
	830	1 028	22,3	12	12	718	1 172	10	0,35	1,9	2,9	1,8
710	762	826	-	12	4	725	855	3	0,11	6,1	9,1	6,3
	788	882	22,3	12	6	733	927	5	0,17	4	5,9	4
	792	868	22,3	12	6	733	927	5	0,22	3	4,6	2,8
	814	941	22,3	12	7,5	738	1 002	6	0,21	3,2	4,8	3,2
	807	918	22,3	12	7,5	738	1 002	6	0,27	2,5	3,7	2,5
	850	1 017	22,3	12	9,5	750	1 110	8	0,28	2,4	3,6	2,5
	826	989	22,3	12	9,5	750	1 110	8	0,37	1,8	2,7	1,8
	875	1 097	22,3	12	12	758	1 232	10	0,35	1,9	2,9	1,8
750	807	873	-	12	5	768	902	4	0,11	6,1	9,1	6,3
	832	930	22,3	12	6	773	977	5	0,16	4,2	6,3	4
	830	916	22,3	12	6	773	977	5	0,22	3	4,6	2,8
	860	998	22,3	12	7,5	778	1 062	6	0,21	3,2	4,8	3,2
	853	970	22,3	12	7,5	778	1 062	6	0,28	2,4	3,6	2,5
	900	1 080	22,3	12	9,5	790	1 180	8	0,28	2,4	3,6	2,5
	875	1 050	22,3	12	9,5	790	1 180	8	0,37	1,8	2,7	1,8
	938	1 163	22,3	12	15	808	1 302	12	0,35	1,9	2,9	1,8
800	862	921	-	12	5	818	962	4	0,15	4,5	6,7	4,5
	885	986	22,3	12	6	823	1 037	5	0,16	4,2	6,3	4
	883	973	22,3	12	6	823	1 037	5	0,21	3,2	4,8	3,2
	915	1 053	22,3	12	7,5	828	1 122	6	0,20	3,4	5	3,2
	908	1 028	22,3	12	7,5	828	1 122	6	0,27	2,5	3,7	2,5
	950	1 141	22,3	12	9,5	840	1 240	8	0,28	2,4	3,6	2,5
	930	1 111	22,3	12	9,5	840	1 240	8	0,35	1,9	2,9	1,8

Spherical roller bearings

d 850 – 1 120 mm

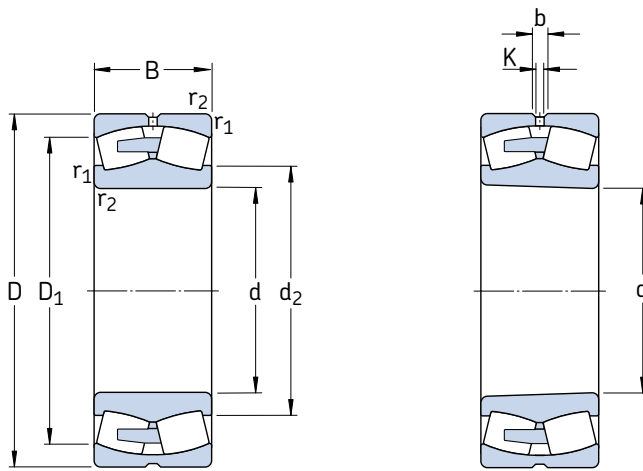

Cylindrical bore

Tapered bore

Principal dimensions			Basic load ratings		Fatigue load limit P_u	Speed ratings		Mass	Designations Bearing with cylindrical bore	tapered bore
d	D	B	C	C_0		Refer- ence speed	Limiting speed			
mm			kN		kN	r/min	kg	–		
850	1 030	136	3 340	10 000	640	260	530	240	238/850 CAMA/W20	238/850 CAKMA/W20
	1 120	200	6 950	15 600	930	280	480	560	* 239/850 CA/W33	* 239/850 CAK/W33
	1 120	272	9 300	22 800	1 370	240	400	740	* 249/850 CA/W33	* 249/850 CAK30/W33
	1 220	272	9 370	21 600	1 270	240	450	1 050	230/850 CA/W33	230/850 CAK/W33
	1 220	365	12 700	31 500	1 900	200	360	1 410	240/850 ECA/W33	240/850 ECAK30/W33
	1 360	400	16 100	34 500	2 000	180	360	2 200	231/850 CA/W33	231/850 CAK/W33
	1 360	500	20 200	45 000	2 550	150	300	2 710	241/850 ECAF/W33	241/850 ECAK30F/W33
900	1 090	190	4 660	15 300	950	240	480	370	248/900 CAMA/W20	248/900 CAK30MA/W20
	1 180	206	7 500	17 000	1 020	260	450	605	* 239/900 CA/W33	* 239/900 CAK/W33
	1 280	280	10 100	23 200	1 340	220	400	1 200	230/900 CA/W33	230/900 CAK/W33
	1 280	375	13 600	34 500	2 040	190	340	1 570	240/900 ECA/W33	240/900 ECAK30/W33
	1 420	515	21 400	49 000	2 700	140	280	3 350	241/900 ECAF/W33	241/900 ECAK30F/W33
950	1 250	224	7 250	19 600	1 120	220	430	755	239/950 CA/W33	239/950 CAK/W33
	1 250	300	9 200	26 000	1 500	180	340	1 015	249/950 CA/W33	249/950 CAK30/W33
	1 360	300	12 000	28 500	1 600	200	380	1 450	230/950 CA/W33	230/950 CAK/W33
	1 360	412	14 800	39 000	2 320	170	300	1 990	240/950 CAF/W33	240/950 CAK30F/W33
	1 500	545	23 900	55 000	3 000	130	260	3 535	241/950 ECAF/W33	241/950 ECAK30F/W33
1 000	1 220	165	4 660	14 300	865	220	400	410	238/1000 CAMA/W20	238/1000 CAKMA/W20
	1 320	315	10 400	29 000	1 500	170	320	1 200	249/1000 CA/W33	249/1000 CAK30/W33
	1 420	308	12 700	30 500	1 700	180	360	1 600	230/1000 CAF/W33	230/1000 CAKF/W33
	1 420	412	15 400	40 500	2 240	160	280	2 140	240/1000 CAF/W33	240/1000 CAK30F/W33
	1 580	462	21 400	48 000	2 550	140	280	3 500	231/1000 CAF/W33	231/1000 CAKF/W33
1 580	580	26 700	62 000	3 350	120	240	4 300	241/1000 ECAF/W33	241/1000 ECAK30F/W33	
1 060	1 280	165	4 770	15 000	800	200	380	435	238/1060 CAMA/W20	238/1060 CAKMA/W20
	1 280	218	6 100	20 000	1 200	200	380	570	248/1060 CAMA/W20	248/1060 CAK30MA/W20
	1 400	250	9 550	26 000	1 460	180	360	1 100	239/1060 CAF/W33	239/1060 CAKF/W33
	1 400	335	11 500	32 500	1 860	160	280	1 400	249/1060 CAF/W33	249/1060 CAK30F/W33
	1 500	325	13 800	34 000	1 830	170	320	2 250	230/1060 CAF/W33	230/1060 CAKF/W33
1 500	438	17 300	45 500	2 500	150	260	2 515	240/1060 CAF/W33	240/1060 CAK30F/W33	
1 120	1 360	243	7 250	24 000	1 400	180	340	735	248/1120 CAF/W20	248/1120 CAK30FA/W20
	1 460	335	11 700	34 500	1 830	140	260	1 500	249/1120 CAF/W33	249/1120 CAK30F/W33
	1 580	462	18 700	50 000	2 850	130	240	2 925	240/1120 CAF/W33	240/1120 CAK30F/W33

* SKF Explorer bearing

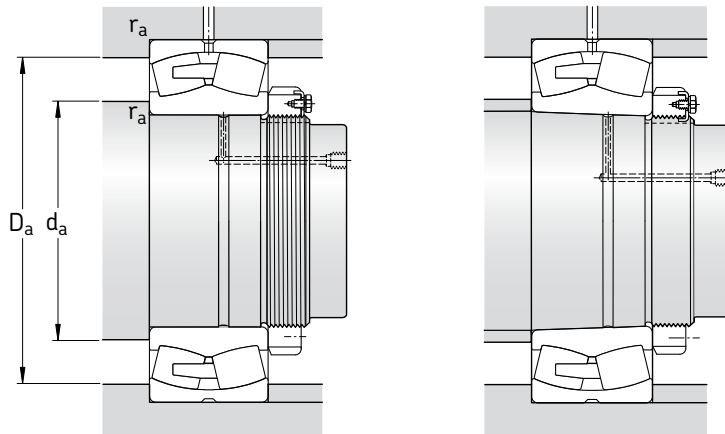

Dimensions					Abutment and fillet dimensions			Calculation factors				
d	d ₂	D ₁	b	K	r _{1,2} min	d _a min	D _a max	r _a max	e	Y ₁	Y ₂	Y ₀
mm						mm			-			
850	910	981	-	12	5	868	1 012	4	0,11	6,1	9,1	6,3
	940	1 046	22,3	12	6	873	1 097	5	0,16	4,2	6,3	4
	940	1 029	22,3	12	6	873	1 097	5	0,22	3	4,6	2,8
	969	1 117	22,3	12	7,5	878	1 192	6	0,20	3,4	5	3,2
	954	1 088	22,3	12	7,5	878	1 192	6	0,27	2,5	3,7	2,5
	1 010	1 205	22,3	12	12	898	1 312	10	0,28	2,4	3,6	2,5
	988	1 182	22,3	12	12	898	1 312	10	0,35	1,9	2,9	1,8
900	966	1 029	-	12	5	918	1 072	4	0,14	4,8	7,2	4,5
	989	1 101	22,3	12	6	923	1 157	5	0,15	4,5	6,7	4,5
	1 023	1 176	22,3	12	7,5	928	1 252	6	0,20	3,4	5	3,2
	1 012	1 149	22,3	12	7,5	928	1 252	6	0,26	2,6	3,9	2,5
	1 043	1 235	22,3	12	12	948	1 372	10	0,35	1,9	2,9	1,8
950	1 049	1 164	22,3	12	7,5	978	1 222	6	0,15	4,5	6,7	4,5
	1 051	1 150	22,3	12	7,5	978	1 222	6	0,21	3,2	4,8	3,2
	1 083	1 246	22,3	12	7,5	978	1 332	6	0,20	3,4	5	3,2
	1 074	1 214	22,3	12	7,5	978	1 332	6	0,27	2,5	3,7	2,5
	1 102	1 305	22,3	12	12	998	1 452	10	0,35	1,9	2,9	1,8
1 000	1 077	1 161	-	12	6	1 023	1 197	5	0,12	5,6	8,4	5,6
	1 106	1 212	22,3	12	7,5	1 028	1 292	6	0,21	3,2	4,8	3,2
	1 139	1 305	22,3	12	7,5	1 028	1 392	6	0,19	3,6	5,3	3,6
	1 133	1 278	22,3	12	7,5	1 028	1 392	6	0,26	2,6	3,9	2,5
	1 182	1 403	22,3	12	12	1 048	1 532	10	0,28	2,4	3,6	2,5
1 159	1 373	22,3	12	12	1 048	1 532	10	0,35	1,9	2,9	1,8	
1 060	1 135	1 219	-	12	6	1 083	1 257	5	0,11	6,1	9,1	6,3
	1 135	1 210	-	12	6	1 083	1 257	5	0,14	4,8	7,2	4,5
	1 171	1 305	22,3	12	7,5	1 088	1 372	6	0,16	4,2	6,3	4
	1 165	1 286	22,3	12	7,5	1 088	1 372	6	0,21	3,2	4,8	3,2
	1 202	1 378	22,3	12	9,5	1 094	1 466	8	0,19	3,6	5,3	3,6
1 196	1 349	22,3	12	9,5	1 094	1 466	8	0,26	2,6	3,9	2,5	
1 120	1 202	1 282	-	12	6	1 143	1 337	5	0,15	4,5	6,7	4,5
	1 230	1 350	22,3	12	7,5	1 148	1 432	6	0,20	3,4	5	3,2
	1 266	1 423	22,3	12	9,5	1 154	1 546	8	0,26	2,6	3,9	2,5

Spherical roller bearings
d 1 180 – 1 800 mm

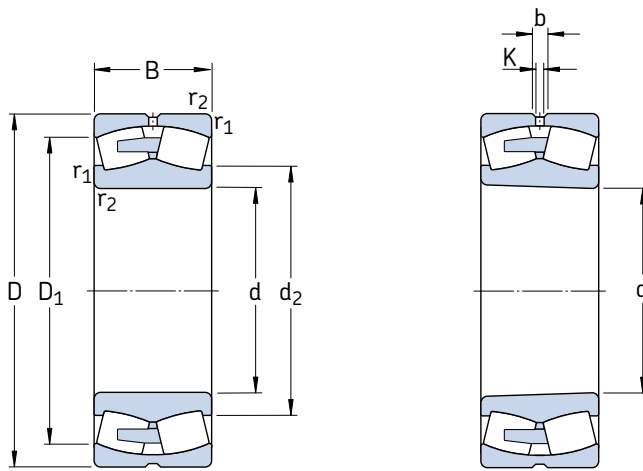

Cylindrical bore

Tapered bore

Principal dimensions			Basic load ratings		Fatigue load limit P_u	Speed ratings		Mass	Designations	
d	D	B	C	C_0		Refer- ence speed	Limiting speed		Bearing with cylindrical bore	tapered bore
mm			kN		kN	r/min	kg	–		
1 180	1 420	180	5 870	18 600	1 080	170	320	575	238/1180 CAFA/W20	238/1180 CAKFA/W20
	1 420	243	7 710	27 000	1 560	170	320	770	248/1180 CAFA/W20	248/1180 CAK30FA/W20
	1 540	272	11 100	31 000	1 660	150	300	1 400	239/1180 CAF/W33	239/1180 CAKF/W33
	1 540	355	13 600	40 500	2 160	130	240	1 800	249/1180 CAF/W33	249/1180 CAK30F/W33
1 250	1 750	375	17 900	45 000	2 400	130	240	2 840	230/1250 CAF/W33	230/1250 CAKF/W33
1 320	1 600	280	9 780	33 500	1 860	140	260	1 160	248/1320 CAFA/W20	248/1320 CAK30FA/W20
	1 720	400	16 100	49 000	2 550	110	200	2 500	249/1320 CAF/W33	249/1320 CAK30F/W33
1 500	1 820	315	12 700	45 000	2 400	110	200	1 710	248/1500 CAFA/W20	248/1500 CAK30FA/W20
1 800	2 180	375	17 600	63 000	3 050	75	130	2 900	248/1800 CAFA/W20	248/1800 CAK30FA/W20

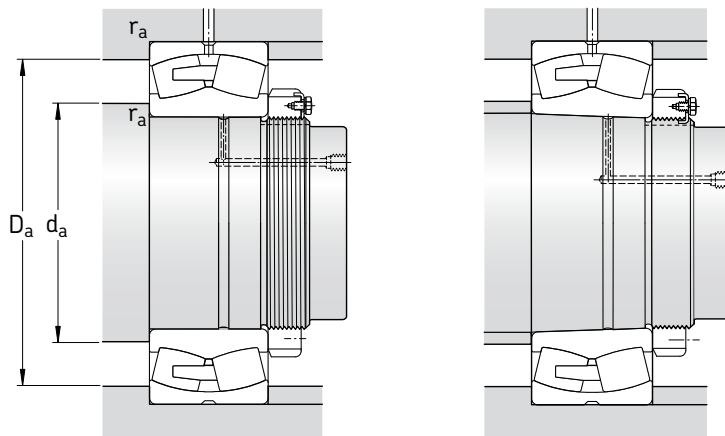

Dimensions					Abutment and fillet dimensions			Calculation factors				
d	d ₂ ~	D ₁ ~	b	K	r _{1,2} min	d _a min	D _a max	r _a max	e	Y ₁	Y ₂	Y ₀
mm						mm			-			
1 180	1 261	1 355	-	12	6	1 203	1 397	5	0,11	6,1	9,1	6,3
	1 268	1 344	-	12	6	1 203	1 397	5	0,14	4,8	7,2	4,5
	1 298	1 439	22,3	12	7,5	1 208	1 512	6	0,16	4,2	6,3	4
	1 303	1 422	22,3	12	7,5	1 208	1 512	6	0,20	3,4	5	3,2
1 250	1 411	1 611	22,3	12	9,5	1 284	1 716	8	0,19	3,6	5,3	3,6
1 320	1 417	1 511	-	12	6	1 343	1 577	5	0,15	4,5	6,7	4,5
	1 445	1 589	22,3	12	7,5	1 348	1 692	6	0,21	3,2	4,8	3,2
1 500	1 612	1 719	-	12	7,5	1 528	1 792	6	0,15	4,5	6,7	4,5
1 800	1 932	2 060	-	12	9,5	1 834	2 146	8	0,15	4,5	6,7	4,5

Sealed spherical roller bearings

d 25 – 100 mm

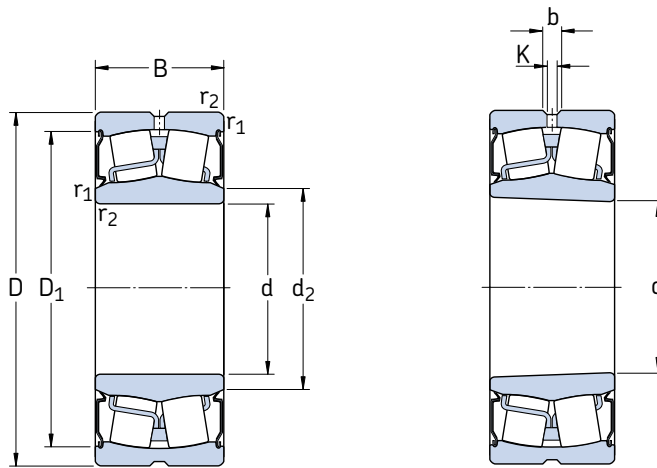

Cylindrical bore

Tapered bore

Principal dimensions			Basic load ratings dynamic static		Fatigue load limit P_u	Limiting speed	Mass	Designations Bearing with cylindrical bore	tapered bore
d	D	B	C	C_0		r/min	kg		
mm			kN		kN			–	
25	52	23	49	44	4,75	3 600	0,31	* BS2-2205-2CS	–
30	62	25	64	60	6,4	2 800	0,34	* BS2-2206-2CS	–
35	72	28	86,5	85	9,3	2 400	0,52	* BS2-2207-2CS	–
40	80	28	96,5	90	9,8	2 200	0,57	* BS2-2208-2CS	* BS2-2208-2CSK
	90	38	150	140	15	1 900	1,20	* BS2-2308-2CS	–
45	85	28	102	98	10,8	2 000	0,66	* BS2-2209-2CS	* BS2-2209-2CSK
50	90	28	104	108	11,8	1 900	0,70	* BS2-2210-2CS	* BS2-2210-2CSK
55	100	31	125	127	13,7	1 700	1,00	* BS2-2211-2CS	* BS2-2211-2CSK
	120	49	270	280	30	1 400	2,80	* BS2-2311-2CS	–
60	110	34	156	166	18,6	1 600	1,30	* BS2-2212-2CS	* BS2-2212-2CSK
65	100	35	132	173	20,4	1 000	0,95	* 24013-2CS5/VT143	–
	120	38	193	216	24	1 500	1,60	* BS2-2213-2CS	* BS2-2213-2CSK
70	125	38	208	228	25,5	1 400	1,80	* BS2-2214-2CS	* BS2-2214-2CSK
75	115	40	173	232	28,5	950	1,55	* 24015-2CS2/VT143	–
	130	38	212	240	26,5	1 300	2,10	* BS2-2215-2CS	* BS2-2215-2CSK
	160	64	440	475	48	950	6,50	* BS2-2315-2CS	–
80	140	40	236	270	29	1 200	2,40	* BS2-2216-2CS	* BS2-2216-2CSK
85	150	44	285	325	34,5	1 100	3,00	* BS2-2217-2CS	* BS2-2217-2CSK
90	160	48	325	375	39	1 000	3,70	* BS2-2218-2CS	* BS2-2218-2CSK
100	150	50	285	415	45,5	800	3,15	* 24020-2CS2/VT143	–
	165	52	365	490	53	850	4,55	* 23120-2CS2/VT143	–
	180	55	425	490	49	900	5,50	* BS2-2220-2CS	–
	180	60,3	475	600	63	700	6,85	* 23220-2CS	–

* SKF Explorer bearing

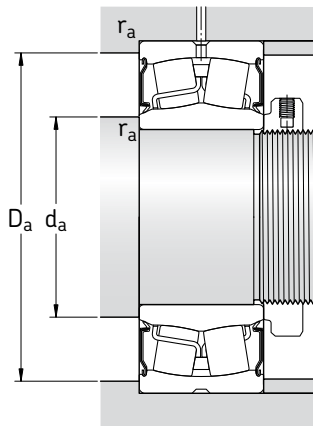

Dimensions						Abutment and fillet dimensions				Calculation factors			
d	d ₂	D ₁	b	K	r _{1,2} min	d _a min	d _a max	D _a max	r _a max	e	Y ₁	Y ₂	Y ₀
mm						mm				-			
25	30	44,6	3,7	2	1	30	30	46,4	1	0,35	1,9	2,9	1,8
30	36	55,7	3,7	2	1	35,6	36	56,4	1	0,31	2,2	3,3	2
35	43	63,7	3,7	2	1,1	42	43	65	1	0,31	2,2	3,3	2,2
40	47 47,5	73 81	5,5 5,5	3 3	1,1 1,5	47 47,5	47 47,5	73 81	1 1,5	0,28 0,37	2,4 1,8	3,6 2,7	2,5 1,8
45	53	77,1	5,5	3	1,1	52	53	78	1	0,26	2,6	3,9	2,5
50	58	82,1	5,5	3	1,1	57	58	83	1	0,24	2,8	4,2	2,8
55	64 67	91,9 109	5,5 5,5	3 3	1,5 2	64 66	64 67	91 109	1,5 2	0,24 0,35	2,8 1,9	4,2 2,9	2,8 1,8
60	69	102	5,5	3	1,5	69	69	101	1,5	0,24	2,8	4,2	2,8
65	71,5 76	92,8 111	3,7 5,5	2 3	1,1 1,5	71 74	71,5 76	94 111	1 1,5	0,27 0,24	2,5 2,8	3,7 4,2	2,5 2,8
70	80	115	5,5	3	1,5	79	80	116	1,5	0,23	2,9	4,4	2,8
75	81,5 84 88	105 119 144	5,5 5,5 8,3	3 3 4,5	1,1 1,5 2,1	81 84 87	81,5 84 88	109 121 148	1 1,5 2	0,28 0,22 0,35	2,4 3 1,9	3,6 4,6 2,9	2,5 2,8 1,8
80	91,5	128	5,5	3	2	91	91,5	129	2	0,22	3	4,6	2,8
85	98	138	5,5	3	2	96	98	139	2	0,22	3	4,6	2,8
90	102	148	5,5	3	2	101	102	149	2	0,24	2,8	4,2	2,8
100	108 112 114 114	139 152 162 161	5,5 5,5 8,3 8,3	3 3 4,5 4,5	1,5 2 2,1 2,1	107 111 112 112	108 112 114 114	143 154 168 168	1,5 2 2 2	0,28 0,27 0,24 0,30	2,4 2,5 2,8 2,3	3,6 3,7 4,2 3,4	2,5 2,5 2,8 2,2

Sealed spherical roller bearings
d 110 – 220 mm

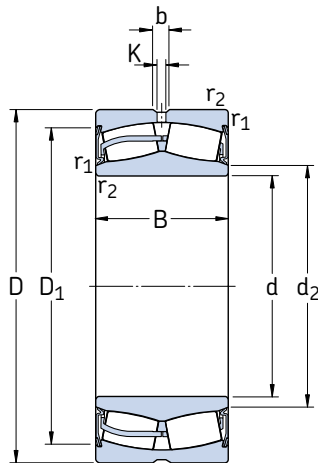

Principal dimensions			Basic load ratings		Fatigue load limit P_u	Limiting speed	Mass	Designation
d	D	B	C	C_0				
mm			kN		kN	r/min	kg	–
110	170	45	310	440	46,5	900	3,75	* 23022-2CS
	180	56	430	585	61	800	5,55	* 23122-2CS2/VT143
	180	69	520	750	78	630	6,85	* 24122-2CS2/VT143
	200	63	560	640	63	800	7,60	* BS2-2222-2CS5/VT143
120	180	46	355	510	52	850	4,20	* 23024-2CS2/VT143
	180	60	430	670	68	670	5,45	* 24024-2CS2/VT143
	200	80	655	950	95	560	10,5	* 24124-2CS2/VT143
	215	69	630	765	73,5	750	9,75	* BS2-2224-2CS
130	200	52	430	610	62	800	6,00	* 23026-2CS2/VT143
	200	69	540	815	81,5	600	8,05	* 24026-2CS2/VT143
	210	80	680	1 000	100	530	11,0	* 24126-2CS2/VT143
140	210	69	570	900	88	560	8,55	* 24028-2CS2/VT143
	225	85	765	1 160	112	450	13,5	* 24128-2CS2/VT143
	250	88	915	1 250	120	530	19,5	* 23228-2CS5/VT143
150	225	75	655	1 040	100	530	10,5	* 24030-2CS2/VT143
	250	100	1 020	1 530	146	400	20,0	* 24130-2CS2/VT143
160	240	80	750	1 200	114	450	13,0	* 24032-2CS2/VT143
	270	86	980	1 370	129	530	20,5	* 23132-2CS2/VT143
170	260	90	930	1 460	137	400	17,5	* 24034-2CS2/VT143
	280	109	1 220	1 860	170	360	27,5	* 24134-2CS2/VT143
180	280	100	1 080	1 730	156	380	23,0	* 24036-2CS2/VT143
190	320	128	1 600	2 500	212	340	43,0	* 24138-2CS2/VT143
200	340	140	1 800	2 800	232	320	53,5	* 24140-2CS
	360	128	1 860	2 700	228	430	58,0	* 23240-2CS2/VT143
220	300	60	546	1 080	93	600	12,5	23944-2CS

* SKF Explorer bearing

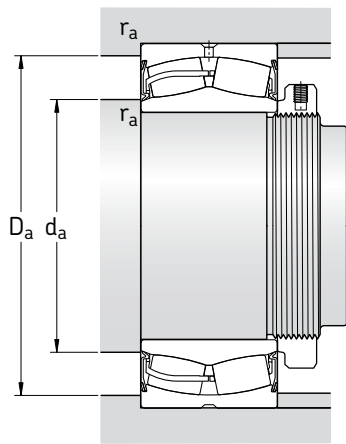

Dimensions						Abutment and fillet dimensions				Calculation factors			
d	d ₂	D ₁	b	K	r _{1,2} min	d _a min	d _a max	D _a max	r _a max	e	Y ₁	Y ₂	Y ₀
mm						mm				-			
110	122	157	8,3	4,5	2	119	122	161	2	0,23	2,9	4,4	2,8
	122	166	8,3	4,5	2	121	122	169	2	0,27	2,5	3,7	2,5
	121	163	5,5	3	2	121	121	169	2	0,35	1,9	2,9	1,8
	126	182	8,3	4,5	2,1	122	126	188	2	0,25	2,7	4	2,5
120	132	172	5,5	3	2	129	132	171	2	0,20	3,4	5	3,2
	130	166	5,5	3	2	129	130	171	2	0,28	2,4	3,6	2,5
	132	179	5,5	3	2	131	132	189	2	0,37	1,8	2,7	1,8
	136	193	11,1	6	2,1	132	136	203	2	0,26	2,6	3,9	2,5
130	145	186	8,3	4,5	2	139	145	191	2	0,21	3,2	4,8	3,2
	140	183	5,5	3	2	139	140	191	2	0,30	2,3	3,4	2,2
	141	190	5,5	3	2	141	141	199	2	0,33	2	3	2
140	151	195	5,5	3	2	149	151	201	2	0,28	2,4	3,6	2,5
	153	203	8,3	4,5	2,1	152	153	213	2	0,35	1,9	2,9	1,8
	165	212	11,1	6	3	154	165	236	2,5	0,33	2	3	2
150	162	206	5,5	3	2,1	161	162	214	2	0,28	2,4	3,6	2,5
	163	222	8,3	4,5	2,1	162	163	238	2	0,37	1,8	2,7	1,8
160	173	218	8,3	4,5	2,1	171	173	229	2	0,28	2,4	3,6	2,5
	180	244	13,9	7,5	2,1	172	180	258	2	0,28	2,4	3,6	2,5
170	184	235	8,3	4,5	2,1	181	184	249	2	0,30	2,3	3,4	2,2
	185	248	8,3	4,5	2,1	182	185	268	2	0,37	1,8	2,7	1,8
180	194	251	8,3	4,5	2,1	191	194	269	2	0,31	2,2	3,3	2,2
190	210	282	11,1	6	3	204	210	306	2,5	0,40	1,7	2,5	1,6
200	221	294	11,1	6	3	214	221	326	2,5	0,40	1,7	2,5	1,6
	229	320	16,7	9	4	217	229	343	3	0,35	1,9	2,9	1,8
220	238	284	8,3	4,5	2,1	231	238	289	2	0,15	4,5	6,7	4,5

**Spherical roller bearings
for vibratory applications**
d 40 – 140 mm

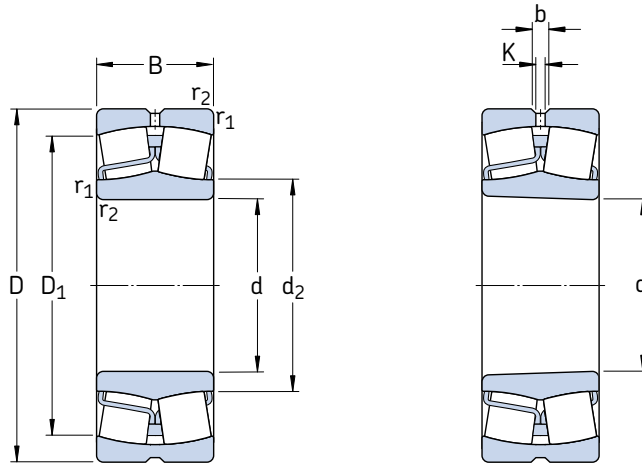

Cylindrical bore

Tapered bore

Principal dimensions			Basic load ratings		Fatigue load limit P_u	Speed ratings		Mass	Designations Bearing with cylindrical bore	tapered bore
d	D	B	C	C_0		Reference speed	Limiting speed			
mm			kN	kN	kN	r/min	kg	–		
40	90	33	150	140	15	6 000	8 000	1,10	* 22308 E/VA405	–
45	100	36	183	183	19,6	5 300	7 000	1,40	* 22309 E/VA405	–
50	110	40	220	224	24	4 800	6 300	1,90	* 22310 E/VA405	–
55	120	43	270	280	30	4 300	5 600	2,45	* 22311 E/VA405	* 22311 EK/VA405
60	130	46	310	335	36,5	4 000	5 300	3,10	* 22312 E/VA405	* 22312 EK/VA405
65	140	48	340	360	38	3 800	5 000	3,75	* 22313 E/VA405	* 22313 EK/VA405
70	150	51	400	430	45	3 400	4 500	4,55	* 22314 E/VA405	* 22314 EK/VA405
75	160	55	440	475	48	3 200	4 300	5,55	* 22315 EJA/VA405	* 22315 EKJA/VA405
80	170	58	490	540	54	3 000	4 000	6,60	* 22316 EJA/VA405	* 22316 EKJA/VA405
85	180	60	550	620	61	2 800	3 800	7,65	* 22317 EJA/VA405	* 22317 EKJA/VA405
	180	60	550	620	61	2 800	3 800	7,65	* 22317 EJA/VA406	–
90	190	64	610	695	67	2 600	3 600	9,05	* 22318 EJA/VA405	* 22318 EKJA/VA405
95	200	67	670	765	73,5	2 600	3 400	10,5	* 22319 EJA/VA405	* 22319 EKJA/VA405
100	215	73	815	950	88	2 400	3 000	13,5	* 22320 EJA/VA405	* 22320 EKJA/VA405
	215	73	815	950	88	2 400	3 000	13,5	* 22320 EJA/VA406	–
110	240	80	950	1 120	100	2 000	2 800	18,4	* 22322 EJA/VA405	* 22322 EKJA/VA405
	240	80	950	1 120	100	2 000	2 800	18,4	* 22322 EJA/VA406	–
120	260	86	965	1 120	100	2 000	2 600	23,0	* 22324 CCJA/W33VA405	* 22324 CCKJA/W33VA405
	260	86	965	1 120	100	2 000	2 600	23,0	* 22324 CCJA/W33VA406	–
130	280	93	1 120	1 320	114	1 800	2 400	29,0	* 22326 CCJA/W33VA405	* 22326 CCKJA/W33VA405
	280	93	1 120	1 320	114	1 800	2 400	29,0	* 22326 CCJA/W33VA406	–
140	300	102	1 290	1 560	132	1 700	2 200	36,5	* 22328 CCJA/W33VA405	* 22328 CCKJA/W33VA405
	300	102	1 290	1 560	132	1 700	2 200	36,5	* 22328 CCJA/W33VA406	–

* SKF Explorer bearing

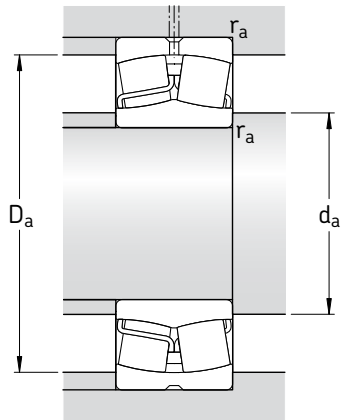

Dimensions						Abutment and fillet dimensions			Calculation factors				Permissible accelerations ¹⁾ for oil lubrication	
d	d ₂	D ₁	b	K	r _{1,2} min	d _a min	D _a max	r _a max	e	Y ₁	Y ₂	Y ₀	rotational	linear
mm						mm			–				m/s ²	
40	49,7	74,3	5,5	3	1,5	49	81	1,5	0,37	1,8	2,7	1,8	115 g	31 g
45	56,4	83,4	5,5	3	1,5	54	91	1,5	0,37	1,8	2,7	1,8	97 g	29 g
50	62,1	91,9	5,5	3	2	61	99	2	0,37	1,8	2,7	1,8	85 g	28 g
55	70,1	102	5,5	3	2	66	109	2	0,35	1,9	2,9	1,8	78 g	26 g
60	77,9	110	8,3	4,5	2,1	72	118	2	0,35	1,9	2,9	1,8	70 g	25 g
65	81,6	118	8,3	4,5	2,1	77	128	2	0,35	1,9	2,9	1,8	69 g	24 g
70	90,3	128	8,3	4,5	2,1	82	138	2	0,33	2	3	2	61 g	23 g
75	92,8	135	8,3	4,5	2,1	87	148	2	0,35	1,9	2,9	1,8	88 g	23 g
80	98,3	143	8,3	4,5	2,1	92	158	2	0,35	1,9	2,9	1,8	80 g	22 g
85	108	154	8,3	4,5	3	99	166	2,5	0,33	2	3	2	74 g	21 g
	108	154	8,3	4,5	3	99	166	2,5	0,33	2	3	2	74 g	21 g
90	113	161	11,1	6	3	104	176	2,5	0,33	2	3	2	68 g	21 g
95	118	168	11,1	6	3	109	186	2,5	0,33	2	3	2	64 g	20 g
100	130	184	11,1	6	3	114	201	2,5	0,33	2	3	2	56 g	20 g
	130	184	11,1	6	3	114	201	2,5	0,33	2	3	2	56 g	20 g
110	143	204	13,9	7,5	3	124	226	2,5	0,33	2	3	2	53 g	19 g
	143	204	13,9	7,5	3	124	226	2,5	0,33	2	3	2	53 g	19 g
120	152	216	13,9	7,5	3	134	246	2,5	0,35	1,9	2,9	1,8	96 g	21 g
	152	216	13,9	7,5	3	134	246	2,5	0,35	1,9	2,9	1,8	96 g	21 g
130	164	233	16,7	9	4	147	263	3	0,35	1,9	2,9	1,8	87 g	20 g
	164	233	16,7	9	4	147	263	3	0,35	1,9	2,9	1,8	87 g	20 g
140	175	247	16,7	9	4	157	283	3	0,35	1,9	2,9	1,8	78 g	20 g
	175	247	16,7	9	4	157	283	3	0,35	1,9	2,9	1,8	78 g	20 g

¹⁾ For details about permissible accelerations → page 700

**Spherical roller bearings
for vibratory applications**
d 150 – 240 mm

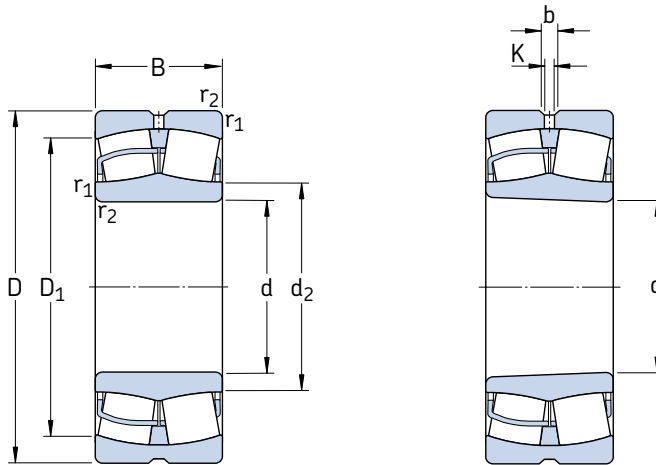

Cylindrical bore

Tapered bore

Principal dimensions			Basic load ratings		Fatigue load limit P_u	Speed ratings		Mass	Designations	
d	D	B	dynamic C	static C_0		Refer- ence speed	Limiting speed		Bearing with cylindrical bore	tapered bore
mm			kN		kN	r/min		kg	–	
150	320	108	1 460	1 760	146	1 600	2 000	43,5	* 22330 CCJA/W33VA405	* 22330 CCKJA/W33VA405
	320	108	1 460	1 760	146	1 600	2 000	43,5	* 22330 CCJA/W33VA406	–
160	340	114	1 600	1 960	160	1 500	1 900	52,0	* 22332 CCJA/W33VA405	* 22332 CCKJA/W33VA405
	340	114	1 600	1 960	160	1 500	1 900	52,0	* 22332 CCJA/W33VA406	–
170	360	120	1 760	2 160	176	1 400	1 800	61,0	* 22334 CCJA/W33VA405	* 22334 CCKJA/W33VA405
	360	120	1 760	2 160	176	1 400	1 800	61,0	* 22334 CCJA/W33VA406	–
180	380	126	2 000	2 450	193	1 300	1 700	71,5	* 22336 CCJA/W33VA405	* 22336 CCKJA/W33VA405
	380	126	2 000	2 450	193	1 300	1 700	71,5	* 22336 CCJA/W33VA406	–
190	400	132	2 120	2 650	208	1 200	1 600	82,5	* 22338 CCJA/W33VA405	* 22338 CCKJA/W33VA405
	400	132	2 120	2 650	208	1 200	1 600	82,5	* 22338 CCJA/W33VA406	–
200	420	138	2 320	2 900	224	1 200	1 500	95,0	* 22340 CCJA/W33VA405	* 22340 CCKJA/W33VA405
	420	138	2 320	2 900	224	1 200	1 500	95,0	* 22340 CCJA/W33VA406	–
220	460	145	2 700	3 450	260	1 000	1 400	120	* 22344 CCJA/W33VA405	* 22344 CCKJA/W33VA405
240	500	155	3 100	4 000	290	950	1 300	155	* 22348 CCJA/W33VA405	* 22348 CCKJA/W33VA405

* SKF Explorer bearing

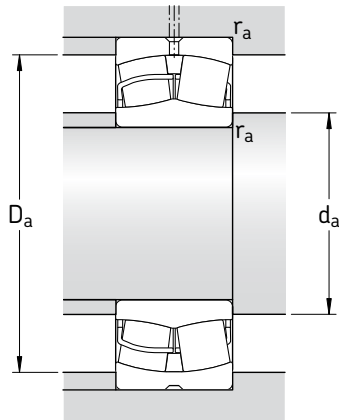

Dimensions						Abutment and fillet dimensions			Calculation factors				Permissible accelerations ¹⁾ for oil lubrication	
d	d ₂ ~	D ₁ ~	b	K	r _{1,2} min	d _a min	D _a max	r _a max	e	Y ₁	Y ₂	Y ₀	rotational	linear
mm						mm			–				m/s ²	
150	188	266	16,7	9	4	167	303	3	0,35	1,9	2,9	1,8	72 g	19 g
	188	266	16,7	9	4	167	303	3	0,35	1,9	2,9	1,8	72 g	19 g
160	200	282	16,7	9	4	177	323	3	0,35	1,9	2,9	1,8	69 g	18 g
	200	282	16,7	9	4	177	323	3	0,35	1,9	2,9	1,8	69 g	18 g
170	213	300	16,7	9	4	187	343	3	0,33	2	3	2	65 g	18 g
	213	300	16,7	9	4	187	343	3	0,33	2	3	2	65 g	18 g
180	224	317	22,3	12	4	197	363	3	0,35	1,9	2,9	1,8	59 g	17 g
	224	317	22,3	12	4	197	363	3	0,35	1,9	2,9	1,8	59 g	17 g
190	236	333	22,3	12	5	210	380	4	0,35	1,9	2,9	1,8	57 g	17 g
	236	333	22,3	12	5	210	380	4	0,35	1,9	2,9	1,8	57 g	17 g
200	248	351	22,3	12	5	220	400	4	0,33	2	3	2	55 g	17 g
	248	351	22,3	12	5	220	400	4	0,33	2	3	2	55 g	17 g
220	279	389	22,3	12	5	240	440	4	0,31	2,2	3,3	2,2	49 g	16 g
240	303	423	22,3	12	5	260	480	4	0,31	2,2	3,3	2,2	45 g	15 g

¹⁾ For details about permissible accelerations → page 700

Spherical roller bearings

on adapter sleeve

d_1 20 – 65 mm

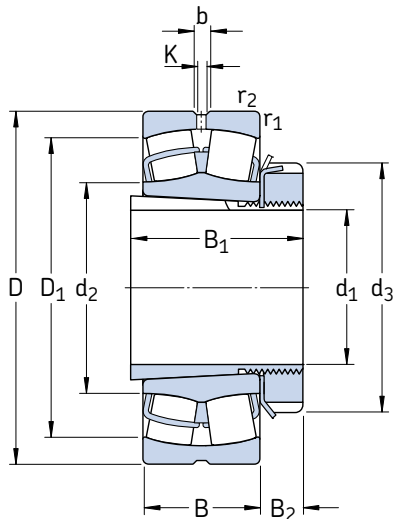

Principal dimensions			Basic load ratings dynamic static		Fatigue load limit	Speed ratings		Mass	Designations	Adapter sleeve
d_1	D	B	C	C_0	P_u	Refer- ence speed	Limiting speed	Bearing + sleeve	Bearing	Adapter sleeve
mm			kN		kN	r/min		kg	–	
20	52	18	49	44	4,75	13 000	17 000	0,33	* 22205 EK	H 305
25	62	20	64	60	6,4	10 000	14 000	0,39	* 22206 EK	H 306
	72	19	55,2	61	6,8	7 500	10 000	0,51	21306 CCK	H 306
30	72	23	86,5	85	9,3	9 000	12 000	0,59	* 22207 EK	H 307
	80	21	65,6	72	8,15	6 700	9 500	0,69	21307 CCK	H 307
35	80	23	96,5	90	9,8	8 000	11 000	0,68	* 22208 EK	H 308
	90	23	104	108	11,8	7 000	9 500	0,92	* 21308 EK	H 308
	90	33	150	140	15	6 000	8 000	1,25	* 22308 EK	H 2308
40	85	23	102	98	10,8	7 500	10 000	0,81	* 22209 EK	H 309
	100	25	125	127	13,7	6 300	8 500	1,20	* 21309 EK	H 309
	100	36	183	183	19,6	5 300	7 000	1,70	* 22309 EK	H 2309
45	90	23	104	108	11,8	7 000	9 500	0,90	* 22210 EK	H 310
	110	27	156	166	18,6	5 600	7 500	1,60	* 21310 EK	H 310
	110	40	220	224	24	4 800	6 300	2,25	* 22310 EK	H 2310
50	100	25	125	127	13,7	6 300	8 500	1,10	* 22211 EK	H 311
	120	29	156	166	18,6	5 600	7 500	1,95	* 21311 EK	H 311
	120	43	270	280	30	4 300	5 600	2,85	* 22311 EK	H 2311
55	110	28	156	166	18,6	5 600	7 500	1,45	* 22212 EK	H 312
	130	31	212	240	26,5	4 800	6 300	2,35	* 21312 EK	H 312
	130	46	310	335	36,5	4 000	5 300	3,50	* 22312 EK	H 2312
60	120	31	193	216	24	5 000	7 000	1,95	* 22213 EK	H 313
	125	31	208	228	25,5	5 000	6 700	2,15	* 22214 EK	H 314
	140	33	236	270	29	4 300	6 000	2,90	* 21313 EK	H 313
	140	48	340	360	38	3 800	5 000	4,20	* 22313 EK	H 2313
	150	35	285	325	34,5	4 000	5 600	3,70	* 21314 EK	H 314
	150	51	400	430	45	3 400	4 500	5,35	* 22314 EK	H 2314
65	130	31	212	240	26,5	4 800	6 300	2,45	* 22215 EK	H 315
	160	37	285	325	34,5	4 000	5 600	4,50	* 21315 EK	H 315
	160	55	440	475	48	3 200	4 300	6,50	* 22315 EK	H 2315

* SKF Explorer bearing

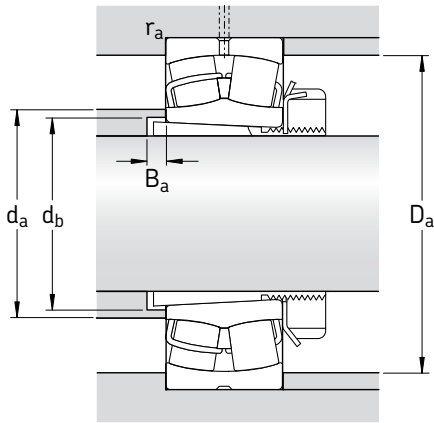

Dimensions									Abutment and fillet dimensions					Calculation factors							
d ₁	d ₂	d ₃	D ₁	B ₁	B ₂	b	K	r _{1,2} min	d _a max	d _b min	D _a max	B _a min	r _a max	e	Y ₁	Y ₂	Y ₀				
mm									mm					-							
20	31,2	38	44,2	29	8	3,7	2	1	31	28	46,4	5	1	0,35	1,9	2,9	1,8				
			53	31					8	37	33	56,4	5					1			
25	37,5	45	58,8	31	8	-	-	1,1	43	33	65	6	1	0,31	2,2	3,3	2,2				
	43,3		58,8	31					8	-	-	43	33					65	6	1	
30	44,5	52	61,8	35	9	3,7	2	1,1	44	39	65	5	1	0,31	2,2	3,3	2,2				
	47,2		65,6	35					9	-	-	47	39					71	7	1,5	
35	49,1	58	69,4	36	10	5,5	3	1,1	49	44	73	5	1	0,28	2,4	3,6	2,5				
	59,9		79,8	36					10	5,5	3	1,5	59					44	81	5	1,5
	49,7		74,3	46					10	5,5	3	1,5	49					45	81	6	1,5
40	54,4	65	74,4	39	11	5,5	3	1,1	54	50	78	7	1	0,26	2,6	3,9	2,5				
	65,3		88	39					11	5,5	3	1,5	65					50	91	5	1,5
	56,4		83,4	50					11	5,5	3	1,5	56					50	91	6	1,5
45	59,9	70	79	42	12	5,5	3	1,1	59	55	83	9	1	0,24	2,8	4,2	2,8				
	71,6		96,8	42					12	5,5	3	2	71					55	99	5	2
	62,1		91,9	55					12	5,5	3	2	62					56	99	6	2
50	65,3	75	88	45	12,5	5,5	3	1,5	65	60	91	10	1,5	0,24	2,8	4,2	2,8				
	71,6		96,2	45					12,5	5,5	3	2	71					60	109	6	2
	70,1		102	59					12,5	5,5	3	2	70					61	109	6	2
55	71,6	80	96,5	47	12,5	5,5	3	1,5	71	65	101	9	1,5	0,24	2,8	4,2	2,8				
	87,8		115	47					12,5	5,5	3	2,1	87					65	118	6	2
	77,9		110	62					12,5	8,3	4,5	2,1	77					66	118	6	2
60	77,6	85	106	50	13,5	5,5	3	1,5	77	70	111	8	1,5	0,24	2,8	4,2	2,8				
	83		111	52					13,5	5,5	3	1,5	83					75	116	9	1,5
	94,7		124	50					13,5	5,5	3	2,1	94					70	128	6	2
65	87,8	98	115	55	14,5	5,5	3	1,5	87	80	121	12	1,5	0,22	3	4,6	2,8				
	101		133	55					14,5	5,5	3	2,1	101					80	148	6	2
	92,8		135	73					14,5	8,3	4,5	2,1	92					82	148	5	2

Spherical roller bearings

on adapter sleeve

d_1 70 – 115 mm

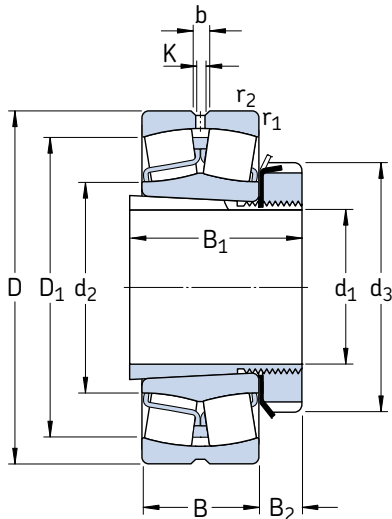

Principal dimensions			Basic load ratings dynamic static		Fatigue load limit	Speed ratings		Mass	Designations	Adapter sleeve
d_1	D	B	C	C_0	P_u	Refer- ence speed	Limiting speed	Bearing + sleeve	Bearing	
mm			kN		kN	r/min		kg	–	
70	140	33	236	270	29	4 300	6 000	3,00	* 22216 EK	H 316
	170	39	325	375	39	3 800	5 300	5,30	* 21316 EK	H 316
	170	58	490	540	54	3 000	4 000	7,65	* 22316 EK	H 2316
75	150	36	285	325	34,5	4 000	5 600	3,70	* 22217 EK	H 317
	180	41	325	375	39	3 800	5 300	6,20	* 21317 EK	H 317
	180	60	550	620	61	2 800	3 800	8,85	* 22317 EK	H 2317
80	160	40	325	375	39	3 800	5 300	4,55	* 22218 EK	H 318
	160	52,4	355	440	48	2 800	3 800	6,00	* 23218 CCK/W33	H 2318
	190	43	380	450	46,5	3 600	4 800	7,25	* 21318 EK	H 318
	190	64	610	695	67	2 600	3 600	10,5	* 22318 EK	H 2318
85	170	43	380	450	46,5	3 600	4 800	5,45	* 22219 EK	H 319
	200	45	425	490	49	3 400	4 500	8,25	* 21319 EK	H 319
	200	67	670	765	73,5	2 600	3 400	12,0	* 22319 EK	H 2319
90	165	52	365	490	53	3 000	4 000	6,15	* 23120 CCK/W33	H 3120
	180	46	425	490	49	3 400	4 500	6,40	* 22220 EK	H 320
	180	60,3	475	600	63	2 400	3 400	8,75	* 23220 CCK/W33	H 2320
	215	47	425	490	49	3 400	4 500	10,5	* 21320 EK	H 320
	215	73	815	950	88	2 400	3 000	15,2	* 22320 EK	H 2320
100	170	45	310	440	46,5	3 400	4 300	5,75	* 23022 CCK/W33	H 322
	180	56	430	585	61	2 800	3 600	7,70	* 23122 CCK/W33	H 3122
	200	53	560	640	63	3 000	4 000	8,90	* 22222 EK	H 322
	200	69,8	600	765	76,5	2 200	3 200	12,5	* 23222 CCK/W33	H 2322
	240	80	950	1 120	100	2 000	2 800	21,0	* 22322 EK	H 2322
110	180	46	355	510	53	3 200	4 000	5,95	* 23024 CCK/W33	H 3024
	200	62	510	695	71	2 600	3 400	10,0	* 23124 CCK/W33	H 3124
	215	58	630	765	73,5	2 800	3 800	11,0	* 22224 EK	H 3124
	215	76	695	930	93	2 000	2 800	14,7	* 23224 CCK/W33	H 2324
	260	86	965	1 120	100	2 000	2 600	25,5	* 22324 CCK/W33	H 2324
115	200	52	430	610	62	2 800	3 600	8,60	* 23026 CCK/W33	H 3026
	210	64	560	780	78	2 400	3 200	12,0	* 23126 CCK/W33	H 3126
	230	64	735	930	88	2 600	3 600	14,0	* 22226 EK	H 3126
	230	80	780	1 060	104	1 900	2 600	18,5	* 23226 CCK/W33	H 2326
	280	93	1 120	1 320	114	1 800	2 400	33,0	* 22326 CCK/W33	H 2326

* SKF Explorer bearing

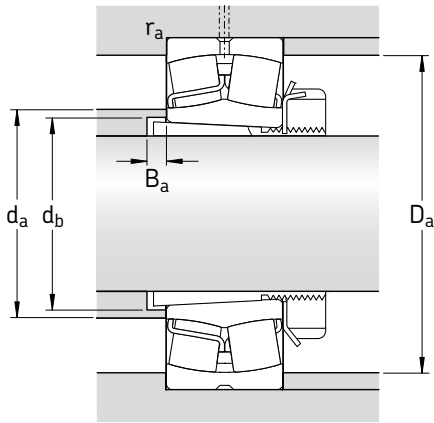

Dimensions									Abutment and fillet dimensions					Calculation factors			
d ₁	d ₂	d ₃	D ₁	B ₁	B ₂	b	K	r _{1,2} min	d _a max	d _b min	D _a max	B _a min	r _a max	e	Y ₁	Y ₂	Y ₀
mm									mm					-			
70	94,7	105	124	59	17	5,5	3	2	94	85	129	12	2	0,22	3	4,6	2,8
	106	105	141	59	17	5,5	3	2,1	106	85	158	6	2	0,24	2,8	4,2	2,8
	98,3	105	143	78	17	8,3	4,5	2,1	98	88	158	6	2	0,35	1,9	2,9	1,8
75	101	110	133	63	18	5,5	3	2	101	91	139	12	2	0,22	3	4,6	2,8
	106	110	141	63	18	5,5	3	3	106	91	166	7	2,5	0,24	2,8	4,2	2,8
	108	110	154	82	18	8,3	4,5	3	108	94	166	7	2,5	0,33	2	3	2
80	106	120	141	65	18	5,5	3	2	106	96	149	10	2	0,24	2,8	4,2	2,8
	106	120	137	86	18	5,5	3	2	106	100	149	18	2	0,31	2,2	3,3	2,2
	112	120	150	65	18	8,3	4,5	3	112	96	176	7	2,5	0,24	2,8	4,2	2,8
	113	120	161	86	18	11,1	6	3	113	100	176	7	2,5	0,33	2	3	2
85	112	125	150	68	19	8,3	4,5	2,1	112	102	158	9	2	0,24	2,8	4,2	2,8
	118	125	159	68	19	8,3	4,5	3	118	102	186	7	2,5	0,24	2,8	4,2	2,8
	118	125	168	90	19	11,1	6	3	118	105	186	7	2,5	0,33	2	3	2
90	115	130	144	76	20	5,5	3	2	115	107	154	6	2	0,30	2,3	3,4	2,2
	118	130	159	71	20	8,3	4,5	2,1	118	108	168	8	2	0,24	2,8	4,2	2,8
	117	130	153	97	20	8,3	4,5	2,1	117	110	168	19	2	0,33	2	3	2
	118	130	159	71	20	8,3	4,5	3	118	108	201	7	2,5	0,24	2,8	4,2	2,8
	130	130	184	97	20	11,1	6	3	130	110	201	7	2,5	0,33	2	3	2
100	125	145	151	77	21	5,5	3	2	125	118	161	14	2	0,23	2,9	4,4	2,8
	126	145	157	81	21	8,3	4,5	2	126	117	169	7	2	0,30	2,3	3,4	2,2
	130	145	178	77	21	8,3	4,5	2,1	130	118	188	6	2	0,25	2,7	4	2,5
	130	145	169	105	21	8,3	4,5	2,1	130	121	188	17	2	0,33	2	3	2
	143	145	204	105	21	13,9	7,5	3	143	121	226	7	2,5	0,33	2	3	2
110	135	145	163	72	22	5,5	3	2	135	127	171	7	2	0,22	3	4,6	2,8
	139	155	174	88	22	8,3	4,5	2	139	128	189	7	2	0,28	2,4	3,6	2,5
	141	155	189	88	22	11,1	6	2,1	141	128	203	11	2	0,26	2,6	3,9	2,5
	141	155	182	112	22	8,3	4,5	2,1	141	131	203	17	2	0,35	1,9	2,9	1,8
	152	155	216	112	22	13,9	7,5	3	152	131	246	7	2,5	0,35	1,9	2,9	1,8
	115	148	155	180	80	23	8,3	4,5	2	148	137	191	8	2	0,23	2,9	4,4
	148	165	184	92	23	8,3	4,5	2	148	138	199	8	2	0,28	2,4	3,6	2,5
	152	165	201	92	23	11,1	6	3	152	138	216	8	2,5	0,27	2,5	3,7	2,5
	151	165	196	121	23	8,3	4,5	3	151	142	216	21	2,5	0,33	2	3	2
	164	165	233	121	23	16,7	9	4	164	142	263	8	3	0,35	1,9	2,9	1,8

Spherical roller bearings

on adapter sleeve

d_1 125 – 170 mm

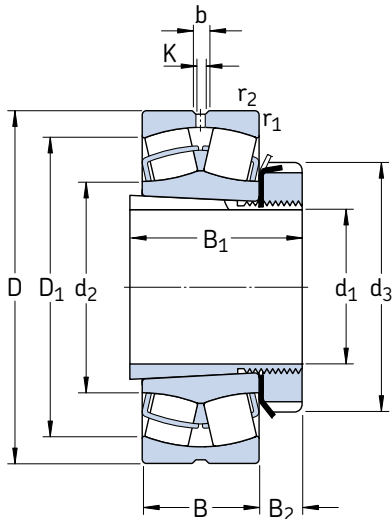

Principal dimensions			Basic load ratings dynamic static		Fatigue load limit	Speed ratings		Mass	Designations	Adapter sleeve
d_1	D	B	C	C_0	P_u	Refer- ence speed	Limiting speed	Bearing + sleeve	Bearing	
mm			kN		kN	r/min		kg	–	
125	210	53	465	680	68	2 600	3 400	9,40	* 23028 CCK/W33	H 3028
	225	68	630	900	88	2 200	2 800	14,3	* 23128 CCK/W33	H 3128
	250	68	710	900	86,5	2 400	3 200	17,8	* 22228 CCK/W33	H 3128
	250	88	915	1 250	120	1 700	2 400	24,0	* 23228 CCK/W33	H 2328
	300	102	1 290	1 560	132	1 700	2 200	41,0	* 22328 CCK/W33	H 2328
135	225	56	510	750	73,5	2 400	3 200	11,0	* 23030 CCK/W33	H 3030
	250	80	830	1 200	114	2 000	2 600	20,8	* 23130 CCK/W33	H 3130
	270	73	850	1 080	102	2 200	3 000	22,8	* 22230 CCK/W33	H 3130
	270	96	1 080	1 460	137	1 600	2 200	30,0	* 23230 CCK/W33	H 2330
	320	108	1 460	1 760	146	1 600	2 000	47,4	* 22330 CCK/W33	H 2330
140	240	60	585	880	83	2 400	3 000	14,5	* 23032 CCK/W33	H 3032
	270	86	980	1 370	129	1 900	2 400	27,3	* 23132 CCK/W33	H 3132
	290	80	1 000	1 290	118	2 000	2 800	29,3	* 22232 CCK/W33	H 3132
	290	104	1 220	1 660	153	1 500	2 200	38,8	* 23232 CCK/W33	H 2332
	340	114	1 600	1 960	160	1 500	1 900	60,0	* 22332 CCK/W33	H 2332
150	260	67	710	1 060	100	2 200	2 800	18,3	* 23034 CCK/W33	H 3034
	280	88	1 040	1 500	137	1 800	2 400	29,5	* 23134 CCK/W33	H 3134
	310	86	1 120	1 460	132	1 900	2 600	36,0	* 22234 CCK/W33	H 3134
	310	110	1 400	1 930	173	1 400	2 000	46,4	* 23234 CCK/W33	H 2334
	360	120	1 760	2 160	176	1 400	1 800	69,5	* 22334 CCK/W33	H 2334
160	250	52	431	830	76,5	2 200	2 800	13,4	23936 CCK/W33	H 3936
	280	74	830	1 250	114	2 000	2 600	23,2	* 23036 CCK/W33	H 3036
	300	96	1 200	1 760	160	1 700	2 200	37,0	* 23136 CCK/W33	H 3136
	320	86	1 180	1 560	140	1 800	2 600	38,2	* 22236 CCK/W33	H 3136
	320	112	1 500	2 120	186	1 300	1 900	49,5	* 23236 CCK/W33	H 2336
	380	126	2 000	2 450	193	1 300	1 700	80,0	* 22336 CCK/W33	H 2336
170	260	52	414	800	76,5	2 200	2 600	14,5	23938 CCK/W33	H 3938
	290	75	865	1 340	122	1 900	2 400	24,8	* 23038 CCK/W33	H 3038
	320	104	1 370	2 080	183	1 500	2 000	44,5	* 23138 CCK/W33	H 3138
	340	92	1 270	1 700	150	1 700	2 400	46,0	* 22238 CCK/W33	H 3138
	340	120	1 660	2 400	208	1 300	1 800	59,0	* 23238 CCK/W33	H 2338
	400	132	2 120	2 650	208	1 200	1 600	93,0	* 22338 CCK/W33	H 2338

* SKF Explorer bearing

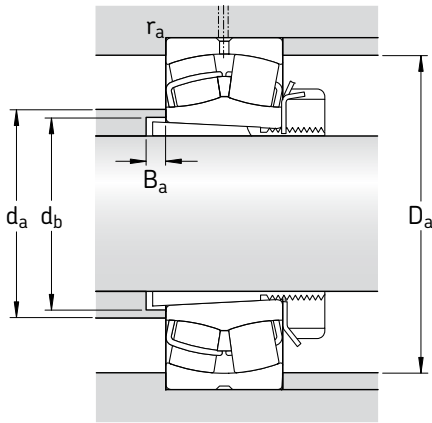

Dimensions									Abutment and fillet dimensions					Calculation factors			
d ₁	d ₂	d ₃	D ₁	B ₁	B ₂	b	K	r _{1,2} min	d _a max	d _b min	D _a max	B _a min	r _a max	e	Y ₁	Y ₂	Y ₀
mm									mm					-			
125	158	165	190	82	24	8,3	4,5	2	158	147	201	8	2	0,22	3	4,6	2,8
	159	180	197	97	24	8,3	4,5	2,1	159	149	213	8	2	0,28	2,4	3,6	2,5
	166	180	216	97	24	11,1	6	3	166	149	236	8	2,5	0,26	2,6	3,9	2,5
	165	180	212	131	24	11,1	6	3	165	152	236	22	2,5	0,33	2	3	2
	175	180	247	131	24	16,7	9	4	175	152	283	8	3	0,35	1,9	2,9	1,8
135	169	180	203	87	26	8,3	4,5	2,1	169	158	214	8	2	0,22	3	4,6	2,8
	172	195	216	111	26	11,1	6	2,1	172	160	238	8	2	0,30	2,3	3,4	2,2
	178	195	234	111	26	13,9	7,5	3	178	160	256	15	2,5	0,26	2,6	3,9	2,5
	175	195	228	139	26	11,1	6	3	175	163	256	20	2,5	0,35	1,9	2,9	1,8
	188	195	266	139	26	16,7	9	4	188	163	303	8	3	0,35	1,9	2,9	1,8
140	180	190	217	93	27,5	11,1	6	2,1	180	168	229	9	2	0,22	3	4,6	2,8
	184	210	234	119	28	13,9	7,5	2,1	184	170	258	8	2	0,30	2,3	3,4	2,2
	191	210	250	119	28	13,9	7,5	3	191	170	276	14	2,5	0,26	2,6	3,9	2,5
	188	210	244	147	28	13,9	7,5	3	188	174	276	18	2,5	0,35	1,9	2,9	1,8
	200	210	282	147	28	16,7	9	4	200	174	323	8	3	0,35	1,9	2,9	1,8
150	191	200	232	101	28,5	11,1	6	2,1	191	179	249	9	2	0,23	2,9	4,4	2,8
	195	220	244	122	29	13,9	7,5	2,1	195	180	268	8	2	0,30	2,3	3,4	2,2
	203	220	267	122	29	16,7	9	4	203	180	293	10	3	0,27	2,5	3,7	2,5
	200	220	261	154	29	13,9	7,5	4	200	185	293	18	3	0,35	1,9	2,9	1,8
	213	220	300	154	29	16,7	9	4	213	185	343	8	3	0,33	2	3	2
160	199	210	231	87	29,5	5,5	3	2	199	188	241	9	2	0,18	3,8	5,6	3,6
	204	210	249	109	29,5	13,9	7,5	2,1	204	189	269	9	2	0,24	2,8	4,2	2,8
	207	230	259	131	30	13,9	7,5	3	207	191	286	8	2,5	0,30	2,3	3,4	2,2
	213	230	278	131	30	16,7	9	4	213	191	303	18	3	0,26	2,6	3,9	2,5
	211	230	271	161	30	13,9	7,5	4	211	195	303	22	3	0,35	1,9	2,9	1,8
	224	230	317	161	30	22,3	12	4	224	195	363	8	3	0,35	1,9	2,9	1,8
170	209	220	240	89	30,5	5,5	3	2	209	198	251	10	2	0,16	4,2	6,3	4
	216	220	261	112	30,5	13,9	7,5	2,1	216	199	279	10	2	0,23	2,9	4,4	2,8
	220	240	275	141	31	13,9	7,5	3	220	202	306	9	2,5	0,31	2,2	3,3	2,2
	225	240	294	141	31	16,7	9	4	225	202	323	21	3	0,26	2,6	3,9	2,5
	222	240	287	169	31	16,7	9	4	222	206	323	21	3	0,35	1,9	2,9	1,8
	236	240	333	169	31	22,3	12	5	236	206	380	9	4	0,35	1,9	2,9	1,8

Spherical roller bearings

on adapter sleeve

d_1 180 – 280 mm

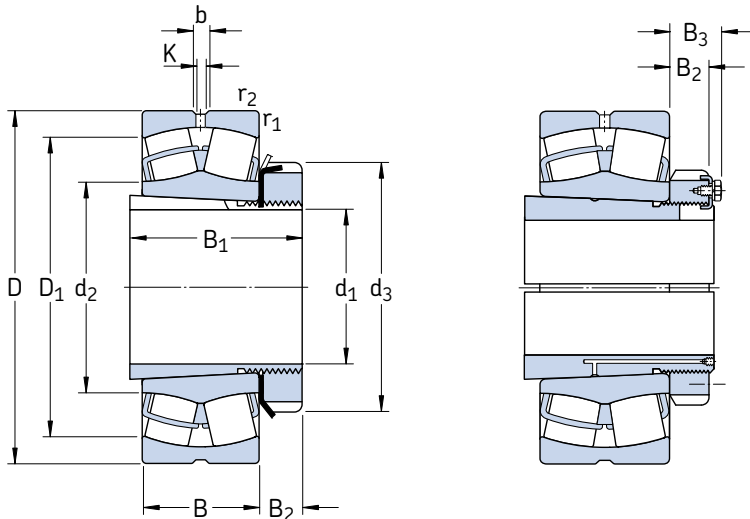

Principal dimensions			Basic load ratings		Fatigue load limit P_u	Speed ratings		Mass Bearing + sleeve	Designations Bearing	Adapter sleeve
d_1	D	B	C	C_0		Refer-ence speed	Limiting speed			
mm			kN		kN	r/min		kg	–	
180	280	60	546	1 040	93	2 000	2 400	19,0	23940 CCK/W33	H 3940
	310	82	1 000	1 530	137	1 800	2 200	31,7	* 23040 CCK/W33	H 3040
	340	112	1 600	2 360	204	1 500	1 900	55,5	* 23140 CCK/W33	H 3140
	360	98	1 460	1 930	166	1 600	2 200	66,0	* 22240 CCK/W33	H 3140
	360	128	1 860	2 700	228	1 200	1 700	70,0	* 23240 CCK/W33	H 2340
	420	138	2 320	2 900	224	1 200	1 500	107	* 22340 CCK/W33	H 2340
200	300	60	546	1 080	93	1 900	2 200	22,5	23944 CCK/W33	OH 3944 H
	340	90	1 220	1 860	163	1 600	2 000	39,4	* 23044 CCK/W33	OH 3044 H
	370	120	1 800	2 750	232	1 300	1 700	67,5	* 23144 CCK/W33	OH 3144 H
	400	108	1 760	2 360	196	1 500	2 000	74,0	* 22244 CCK/W33	OH 3144 H
	400	144	2 360	3 450	285	1 100	1 500	96,5	* 23244 CCK/W33	OH 2344 H
	460	145	2 700	3 450	260	1 000	1 400	135	* 22344 CCK/W33	OH 2344 H
220	320	60	564	1 160	98	1 700	2 000	24,5	23948 CCK/W33	OH 3948 H
	360	92	1 290	2 080	176	1 500	1 900	44,5	* 23048 CCK/W33	OH 3048 H
	400	128	2 080	3 200	255	1 200	1 600	80,5	* 23148 CCK/W33	OH 3148 H
	440	120	2 200	3 000	245	1 300	1 800	99,0	* 22248 CCK/W33	OH 3148 H
	440	160	2 900	4 300	345	950	1 300	125	* 23248 CCK/W33	OH 2348 H
	500	155	3 100	4 000	290	950	1 300	170	* 22348 CCK/W33	OH 2348 H
240	360	75	880	1 800	156	1 500	1 900	35,0	23952 CCK/W33	OH 3952 H
	400	104	1 600	2 550	212	1 300	1 700	60,5	* 23052 CCK/W33	OH 3052 H
	440	144	2 550	3 900	290	1 100	1 400	109	* 23152 CCK/W33	OH 3152 H
	480	130	2 650	3 550	285	1 200	1 600	130	* 22252 CCK/W33	OH 3152 H
	480	174	3 250	4 750	360	850	1 200	160	* 23252 CCK/W33	OH 2352 H
	540	165	3 550	4 550	325	850	1 100	215	* 22352 CCK/W33	OH 2352 H
260	380	75	845	1 760	143	1 400	1 700	40,0	23956 CCK/W33	OH 3956 H
	420	106	1 730	2 850	224	1 300	1 600	67,0	* 23056 CCK/W33	OH 3056 H
	460	146	2 650	4 250	335	1 000	1 300	115	* 23156 CCK/W33	OH 3156 H
	500	130	2 700	3 750	300	1 100	1 500	135	* 22256 CCK/W33	OH 3156 H
	500	176	3 250	4 900	365	800	1 100	165	* 23256 CCK/W33	OH 2356 H
	580	175	4 000	5 200	365	800	1 100	250	* 22356 CCK/W33	OH 2356 H
280	420	90	1 200	2 500	200	1 300	1 600	58,5	23960 CCK/W33	OH 3960 H
	460	118	2 120	3 450	265	1 200	1 500	90,0	* 23060 CCK/W33	OH 3060 H
	500	160	3 200	5 100	380	950	1 200	150	* 23160 CCK/W33	OH 3160 H
	540	140	3 150	4 250	325	1 000	1 400	170	* 22260 CCK/W33	OH 3160 H
	540	192	3 900	5 850	425	750	1 000	210	* 23260 CCK/W33	OH 3260 H

* SKF Explorer bearing

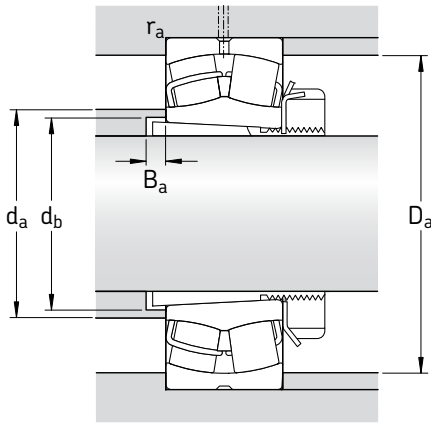

Dimensions										Abutment and fillet dimensions					Calculation factors			
d ₁	d ₂	d ₃	D ₁	B ₁	B ₂	B ₃	b	K	r _{1,2} min	d _a max	d _b min	D _a max	B _a min	r _a max	e	Y ₁	Y ₂	Y ₀
mm										mm					-			
180	222	240	258	98	31,5	-	8,3	4,5	2,1	222	208	269	10	2	0,19	3,6	5,3	3,6
	228	240	278	120	31,5	-	13,9	7,5	2,1	228	210	299	10	2	0,24	2,8	4,2	2,8
	231	250	293	150	32	-	16,7	9	3	231	212	326	9	2,5	0,31	2,2	3,3	2,2
	238	250	313	150	32	-	16,7	9	4	238	212	343	24	3	0,26	2,6	3,9	2,5
	235	250	304	176	32	-	16,7	9	4	235	216	343	19	3	0,35	1,9	2,9	1,8
	248	250	351	176	32	-	22,3	12	5	248	216	400	9	4	0,33	2	3	2
200	241	260	278	96	30	41	8,3	4,5	2,1	241	229	289	12	2	0,16	4,2	6,3	4
	250	260	306	126	30	41	13,9	7,5	3	250	231	327	10	2,5	0,24	2,8	4,2	2,8
	255	280	320	161	35	-	16,7	9	4	255	233	353	10	3	0,30	2,3	3,4	2,2
	263	280	346	161	35	-	16,7	9	4	263	233	383	21	3	0,27	2,5	3,7	2,5
	259	280	338	186	35	-	16,7	9	4	259	236	383	11	3	0,35	1,9	2,9	1,8
	279	280	389	186	35	-	22,3	12	5	279	236	440	10	4	0,31	2,2	3,3	2,2
220	261	290	298	101	34	46	8,3	4,5	2,1	261	249	309	12	2	0,15	4,5	6,7	4,5
	271	290	326	133	34	46	13,9	7,5	3	271	251	347	11	2,5	0,23	2,9	4,4	2,8
	277	300	348	172	37	-	16,7	9	4	277	254	383	11	3	0,30	2,3	3,4	2,2
	290	300	383	172	37	-	22,3	12	4	290	254	423	19	3	0,27	2,5	3,7	2,5
	286	300	374	199	37	-	22,3	12	4	286	257	423	6	3	0,35	1,9	2,9	1,8
	303	300	423	199	37	-	22,3	12	5	303	257	480	11	4	0,31	2,2	3,3	2,2
240	287	310	331	116	34	46	8,3	4,5	2,1	287	270	349	12	2	0,18	3,8	5,6	3,6
	295	310	360	145	34	46	16,7	9	4	295	272	385	11	3	0,23	2,9	4,4	2,8
	301	330	380	190	39	-	16,7	9	4	301	276	423	11	3	0,31	2,2	3,3	2,2
	311	330	421	190	39	-	22,3	12	5	311	276	460	25	4	0,27	2,5	3,7	2,5
	312	330	408	211	39	-	22,3	12	5	312	278	460	2	4	0,35	1,9	2,9	1,8
	328	330	458	211	39	-	22,3	12	6	328	278	514	11	5	0,31	2,2	3,3	2,2
260	308	330	352	121	38	50	11,1	6	2,1	308	290	369	12	2	0,16	4,2	6,3	4
	315	330	380	152	38	50	16,7	9	4	315	292	405	12	3	0,23	2,9	4,4	2,8
	321	350	401	195	41	-	16,7	9	5	321	296	440	12	4	0,30	2,3	3,4	2,2
	333	350	441	195	41	-	22,3	12	5	333	296	480	28	4	0,26	2,6	3,9	2,5
	332	350	429	224	41	-	22,3	12	5	332	299	480	11	4	0,35	1,9	2,9	1,8
	354	350	492	224	41	-	22,3	12	6	354	299	554	12	5	0,30	2,3	3,4	2,2
280	333	360	385	140	42	54	11,1	6	3	333	312	407	13	2,5	0,19	3,6	5,3	3,6
	340	360	414	168	42	54	16,7	9	4	340	313	445	12	3	0,23	2,9	4,4	2,8
	345	380	434	208	40	53	16,7	9	5	345	318	480	12	4	0,30	2,3	3,4	2,2
	354	380	477	208	40	53	22,3	12	5	354	318	520	32	4	0,26	2,6	3,9	2,5
	356	380	461	240	40	53	22,3	12	5	356	321	520	12	4	0,35	1,9	2,9	1,8

Spherical roller bearings

on adapter sleeve

d_1 300 – 410 mm

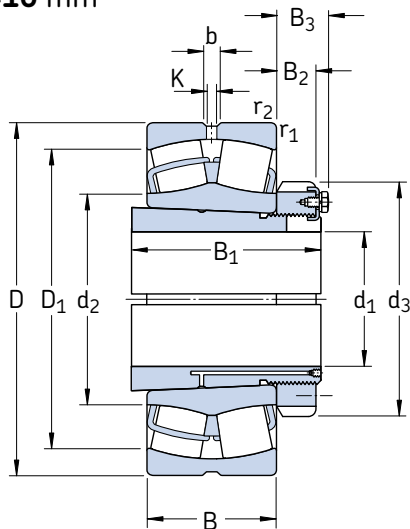

Principal dimensions			Basic load ratings		Fatigue load limit P_u	Speed ratings		Mass Bearing + sleeve	Designations Bearing	Adapter sleeve
d_1	D	B	C	C_0		Refer- ence speed	Limiting speed			
mm			kN		kN	r/min		kg	–	
300	440	90	1 430	2 700	212	1 400	1 500	61,0	* 23964 CCK/W33	OH 3964 H
	480	121	2 240	3 800	285	1 100	1 400	97,0	* 23064 CCK/W33	OH 3064 H
	540	176	3 750	6 000	440	850	1 100	185	* 23164 CCK/W33	OH 3164 H
	580	150	3 600	4 900	375	950	1 300	200	* 22264 CCK/W33	OH 3164 H
	580	208	4 400	6 700	480	700	950	260	* 23264 CCK/W33	OH 3264 H
320	460	90	1 460	2 800	216	1 300	1 400	67,5	* 23968 CCK/W33	OH 3968 H
	520	133	2 700	4 550	335	1 000	1 300	130	* 23068 CCK/W33	OH 3068 H
	580	190	4 250	6 800	480	800	1 000	250	* 23168 CCK/W33	OH 3168 H
	620	224	5 100	7 800	550	560	800	335	* 23268 CAK/W33	OH 3268 H
340	480	90	1 400	2 750	220	1 200	1 300	70,5	* 23972 CCK/W33	OH 3972 H
	540	134	2 750	4 800	345	950	1 200	135	* 23072 CCK/W33	OH 3072 H
	600	192	4 300	6 950	490	750	1 000	260	* 23172 CCK/W33	OH 3172 H
	650	170	4 300	6 200	440	630	850	375	* 22272 CAK/W33	OH 3172 H
	650	232	5 400	8 300	570	530	750	375	* 23272 CAK/W33	OH 3272 H
360	520	106	1 960	3 800	285	1 100	1 200	96,0	* 23976 CCK/W33	OH 3976 H
	560	135	2 900	5 000	360	900	1 200	145	* 23076 CCK/W33	OH 3076 H
	620	194	4 400	7 100	500	560	1 000	275	* 23176 CAK/W33	OH 3176 H
	680	240	5 850	9 150	620	500	750	420	* 23276 CAK/W33	OH 3276 H
380	540	106	2 000	3 900	290	1 100	1 200	100	* 23980 CCK/W33	OH 3980 H
	600	148	3 250	5 700	400	850	1 100	180	* 23080 CCK/W33	OH 3080 H
	650	200	4 650	7 650	530	530	950	325	* 23180 CAK/W33	OH 3180 H
	720	256	6 550	10 400	680	480	670	505	* 23280 CAK/W33	OH 3280 H
	820	243	7 500	10 400	670	430	750	735	* 22380 CAK/W33	OH 3280 H
400	560	106	2 040	4 150	300	1 000	1 100	105	* 23984 CCK/W33	OH 3984 H
	620	150	3 400	6 000	415	600	1 100	190	* 23084 CAK/W33	OH 3084 H
	700	224	5 600	9 300	620	480	900	410	* 23184 CKJ/W33	OH 3184 H
	760	272	7 350	11 600	765	450	630	590	* 23284 CAK/W33	OH 3284 H
410	600	118	2 450	4 900	345	950	1 000	150	* 23988 CCK/W33	OH 3988 H
	650	157	3 650	6 550	450	560	1 000	235	* 23088 CAK/W33	OH 3088 H
	720	226	6 000	10 000	670	450	850	430	* 23188 CAK/W33	OH 3188 H
	790	280	7 800	12 500	800	430	600	670	* 23288 CAK/W33	OH 3288 H

* SKF Explorer bearing

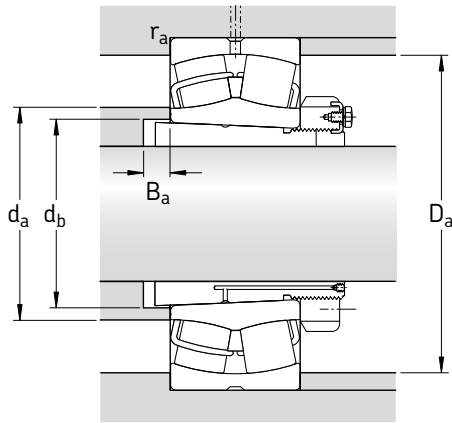

Dimensions										Abutment and fillet dimensions					Calculation factors			
d ₁	d ₂	d ₃	D ₁	B ₁	B ₂	B ₃	b	K	r _{1,2} min	d _a max	d _b min	D _a max	B _a min	r _a max	e	Y ₁	Y ₂	Y ₀
mm										mm					-			
300	354	380	406	140	42	55	11,1	6	3	354	332	427	13	2,5	0,17	4	5,9	4
	360	380	434	171	42	55	16,7	9	4	360	334	465	13	3	0,23	2,9	4,4	2,8
	370	400	465	226	42	56	22,3	12	5	370	338	520	13	4	0,31	2,2	3,3	2,2
	379	400	513	226	42	56	22,3	12	5	379	338	560	39	4	0,26	2,6	3,9	2,5
	382	400	493	258	42	56	22,3	12	5	382	343	560	13	4	0,35	1,9	2,9	1,8
320	373	400	426	144	45	58	11,1	6	3	373	352	447	14	2,5	0,17	4	5,9	4
	385	400	468	187	45	58	22,3	12	5	385	355	502	14	4	0,24	2,8	4,2	2,8
	394	440	498	254	55	72	22,3	12	5	394	360	560	14	4	0,31	2,2	3,3	2,2
	426	440	528	288	55	72	22,3	12	6	426	364	594	14	5	0,35	1,9	2,9	1,8
340	394	420	447	144	45	58	11,1	6	3	394	372	467	14	2,5	0,15	4,5	6,7	4,5
	404	420	483	188	45	58	22,3	12	5	404	375	522	14	4	0,23	2,9	4,4	2,8
	418	460	524	259	58	75	22,3	12	5	418	380	580	14	4	0,30	2,3	3,4	2,2
	453	460	568	259	58	75	22,3	12	6	453	380	624	36	5	0,26	2,6	3,9	2,5
	447	460	552	299	58	75	22,3	12	6	447	385	624	14	5	0,35	1,9	2,9	1,8
360	419	450	481	164	48	62	13,9	7,5	4	419	393	505	15	3	0,17	4	5,9	4
	426	450	509	193	48	62	22,3	12	5	426	396	542	15	4	0,22	3	4,6	2,8
	452	490	541	264	60	77	22,3	12	5	452	401	600	15	4	0,30	2,3	3,4	2,2
	471	490	581	310	60	77	22,3	12	6	471	405	654	15	5	0,35	1,9	2,9	1,8
380	439	470	500	168	52	66	13,9	7,5	4	439	413	525	15	3	0,16	4,2	6,3	4
	450	470	543	210	52	66	22,3	12	5	450	417	582	15	4	0,23	2,9	4,4	2,8
	474	520	566	272	62	82	22,3	12	6	474	421	624	15	5	0,28	2,4	3,6	2,5
	499	520	615	328	62	82	22,3	12	6	499	427	694	15	5	0,35	1,9	2,9	1,8
	534	520	697	328	62	82	22,3	12	7,5	534	427	788	28	6	0,30	2,3	3,4	2,2
400	459	490	520	168	52	66	16,7	9	4	459	433	545	15	3	0,16	4,2	6,3	4
	485	490	563	212	52	66	22,3	12	5	485	437	602	16	4	0,22	3	4,6	2,8
	483	540	607	304	70	90	22,3	12	6	483	443	674	16	5	0,30	2,3	3,4	2,2
	525	540	649	352	70	90	22,3	12	7,5	525	446	728	16	6	0,35	1,9	2,9	1,8
410	484	520	553	189	60	77	16,7	9	4	484	454	585	17	3	0,16	4,2	6,3	4
	509	520	590	228	60	77	22,3	12	6	509	458	627	17	5	0,22	3	4,6	2,8
	528	560	632	307	70	90	22,3	12	6	528	463	694	17	5	0,30	2,3	3,4	2,2
	547	560	676	361	70	90	22,3	12	7,5	547	469	758	17	6	0,35	1,9	2,9	1,8

Spherical roller bearings

on adapter sleeve

d_1 430 – 630 mm

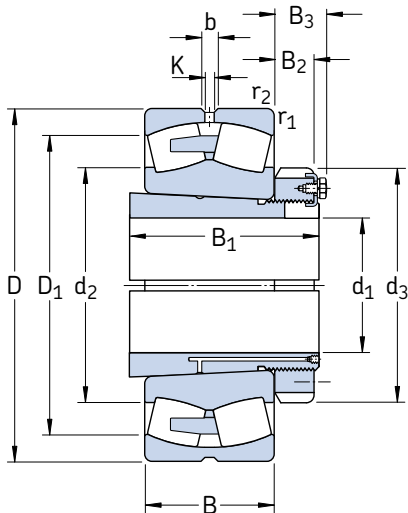

Principal dimensions			Basic load ratings		Fatigue load limit P_u	Speed ratings		Mass Bearing + sleeve	Designations Bearing	Adapter sleeve
d_1	D	B	dynamic	static		Reference speed	Limiting speed			
mm			C	C_0	kN	r/min	kg	–		
430	620	118	2 500	5 000	355	600	1 000	160	* 23992 CAK/W33	OH 3992 H
	680	163	3 900	6 950	465	560	950	265	* 23092 CAK/W33	OH 3092 H
	760	240	6 400	10 800	680	430	800	530	* 23192 CAK/W33	OH 3192 H
	830	296	8 500	13 700	880	400	560	790	* 23292 CAK/W33	OH 3292 H
450	650	128	2 900	5 700	405	560	1 000	185	* 23996 CAK/W33	OH 3996 H
	700	165	3 900	6 800	450	530	950	275	* 23096 CAK/W33	OH 3096 H
	790	248	6 950	12 000	780	400	750	590	* 23196 CAK/W33	OH 3196 H
	870	310	9 300	15 000	950	380	530	935	* 23296 CAK/W33	OH 3296 H
470	670	128	2 900	6 000	415	530	950	195	* 239/500 CAK/W33	OH 39/500 H
	720	167	4 150	7 800	510	500	900	290	* 230/500 CAK/W33	OH 30/500 H
	830	264	7 650	12 900	830	380	700	690	* 231/500 CAK/W33	OH 31/500 H
	920	336	10 600	17 300	1 060	360	500	1 100	* 232/500 CAK/W33	OH 32/500 H
500	710	136	3 200	6 700	480	500	900	255	* 239/530 CAK/W33	OH 39/530 H
	780	185	5 100	9 300	630	450	800	395	* 230/530 CAK/W33	OH 30/530 H
	870	272	8 150	14 000	915	360	670	765	* 231/530 CAK/W33	OH 31/530 H
	980	355	11 100	20 400	1 220	300	480	1 490	232/530 CAK/W33	OH 32/530 H
530	750	140	3 450	7 200	510	450	850	260	* 239/560 CAK/W33	OH 39/560 H
	820	195	5 600	10 200	680	430	750	445	* 230/560 CAK/W33	OH 30/560 H
	920	280	9 150	16 000	980	340	630	880	* 231/560 CAK/W33	OH 31/560 H
	1 030	365	11 500	22 000	1 400	280	430	1 490	232/560 CAK/W33	OH 32/560 H
560	800	150	3 900	8 300	585	430	750	330	* 239/600 CAK/W33	OH 39/600 H
	870	200	6 000	11 400	750	400	700	525	* 230/600 CAK/W33	OH 30/600 H
	980	300	10 200	18 000	1 100	320	560	1 070	* 231/600 CAK/W33	OH 31/600 H
	1 090	388	13 100	25 500	1 560	260	400	1 780	232/600 CAK/W33	OH 32/600 H
600	850	165	4 650	9 800	640	400	700	385	* 239/630 CAK/W33	OH 39/630 H
	920	212	6 700	12 500	800	380	670	595	* 230/630 CAK/W33	OH 30/630 H
	1 030	315	10 500	20 800	1 220	260	530	1 240	231/630 CAK/W33	OH 31/630 H
630	900	170	5 000	10 800	695	360	670	455	* 239/670 CAK/W33	OH 39/670 H
	980	230	7 650	14 600	915	340	600	755	* 230/670 CAK/W33	OH 30/670 H
	1 090	336	10 900	22 400	1 370	240	500	1 510	231/670 CAK/W33	OH 31/670 H
	1 220	438	15 400	30 500	1 700	220	360	2 535	232/670 CAK/W33	OH 32/670 H

* SKF Explorer bearing

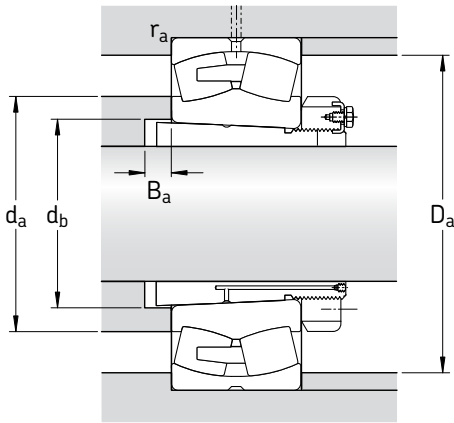

Dimensions										Abutment and fillet dimensions					Calculation factors			
d ₁	d ₂	d ₃	D ₁	B ₁	B ₂	B ₃	b	K	r _{1,2} min	d _a max	d _b min	D _a max	B _a min	r _a max	e	Y ₁	Y ₂	Y ₀
mm										mm					-			
430	512	540	574	189	60	77	16,7	9	4	512	474	605	17	3	0,16	4,2	6,3	4
	531	540	617	234	60	77	22,3	12	6	531	478	657	17	5	0,22	3	4,6	2,8
	553	580	666	326	75	95	22,3	12	7,5	553	484	728	17	6	0,30	2,3	3,4	2,2
	572	580	706	382	75	95	22,3	12	7,5	572	490	798	17	6	0,35	1,9	2,9	1,8
450	532	560	602	200	60	77	16,7	9	5	532	496	632	18	4	0,18	3,8	5,6	3,6
	547	560	633	237	60	77	22,3	12	6	547	499	677	18	5	0,21	3,2	4,8	3,2
	577	620	692	335	75	95	22,3	12	7,5	577	505	758	18	6	0,30	2,3	3,4	2,2
	600	620	741	397	75	95	22,3	12	7,5	600	512	838	18	6	0,35	1,9	2,9	1,8
470	557	580	622	208	68	85	22,3	12	5	557	516	652	18	4	0,17	4	5,9	4
	571	580	658	247	68	85	22,3	12	6	571	519	697	18	5	0,21	3,2	4,8	3,2
	603	630	726	356	80	100	22,3	12	7,5	603	527	798	18	6	0,30	2,3	3,4	2,2
	631	630	779	428	80	100	22,3	12	7,5	631	534	888	18	6	0,35	1,9	2,9	1,8
500	589	630	661	216	68	90	22,3	12	5	589	547	692	20	4	0,17	4	5,9	4
	611	630	710	265	68	90	22,3	12	6	611	551	757	20	5	0,22	3	4,6	2,8
	636	670	763	364	80	105	22,3	12	7,5	636	558	838	20	6	0,30	2,3	3,4	2,2
	668	670	836	447	80	105	22,3	12	9,5	668	566	940	20	8	0,35	1,9	2,9	1,8
530	625	650	697	227	75	97	22,3	12	5	625	577	732	20	4	0,16	4,2	6,3	4
	644	650	746	282	75	97	22,3	12	6	644	582	797	20	5	0,22	3	4,6	2,8
	673	710	809	377	85	110	22,3	12	7,5	673	589	888	20	6	0,30	2,3	3,4	2,2
	704	710	878	462	85	110	22,3	12	9,5	704	595	990	20	8	0,35	1,9	2,9	1,8
560	668	700	744	239	75	97	22,3	12	5	668	619	782	22	4	0,17	4	5,9	4
	683	700	789	289	75	97	22,3	12	6	683	623	847	22	5	0,22	3	4,6	2,8
	720	750	863	399	85	110	22,3	12	7,5	720	629	948	22	6	0,30	2,3	3,4	2,2
	752	750	929	487	85	110	22,3	12	9,5	752	639	1 050	22	8	0,35	1,9	2,9	1,8
600	705	730	787	254	75	97	22,3	12	6	705	650	827	22	5	0,17	4	5,9	4
	725	730	839	301	75	97	22,3	12	7,5	725	654	892	22	6	0,21	3,2	4,8	3,2
	755	800	918	424	95	120	22,3	12	7,5	755	663	998	22	6	0,30	2,3	3,4	2,2
630	749	780	835	264	80	102	22,3	12	6	749	691	877	22	5	0,17	4	5,9	4
	770	780	892	324	80	102	22,3	12	7,5	770	696	952	22	6	0,21	3,2	4,8	3,2
	802	850	959	456	106	131	22,3	12	7,5	802	705	1 058	22	6	0,30	2,3	3,4	2,2
	830	850	1 028	558	106	131	22,3	12	12	830	711	1 172	22	10	0,35	1,9	2,9	1,8

Spherical roller bearings

on adapter sleeve

d_1 670 – 1 000 mm

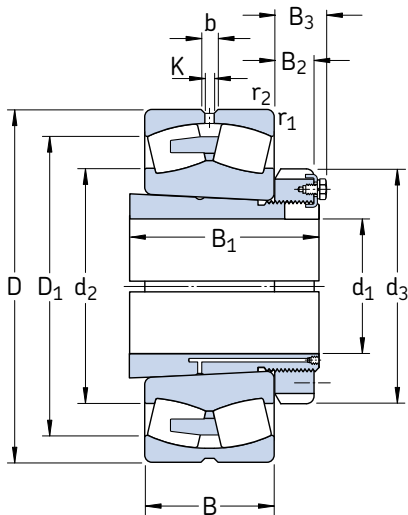

Principal dimensions			Basic load ratings		Fatigue load limit P_u	Speed ratings		Mass Bearing + sleeve	Designations Bearing	Adapter sleeve
d_1	D	B	dynamic C	static C_0		Refer- ence speed	Limiting speed			
mm			kN		kN	r/min		kg	–	
670	950	180	5 600	12 000	765	340	600	525	* 239/710 CAK/W33	OH 39/710 H
	1 030	236	8 300	16 300	1 000	320	560	860	* 230/710 CAK/W33	OH 30/710 H
	1 150	345	12 200	26 000	1 530	240	450	1 750	231/710 CAK/W33	OH 31/710 H
	1 280	450	17 600	34 500	2 000	200	320	3 350	232/710 CAK/W33	OH 32/710 H
710	1 000	185	6 000	13 200	815	320	560	605	* 239/750 CAK/W33	OH 39/750 H
	1 090	250	9 650	18 600	1 100	300	530	990	* 230/750 CAK/W33	OH 30/750 H
	1 220	365	13 800	29 000	1 660	220	430	2 045	231/750 CAK/W33	OH 31/750 H
	1 360	475	18 700	36 500	2 120	190	300	3 400	232/750 CAKF/W33	OH 32/750 H
750	1 060	195	6 400	14 300	880	300	530	730	* 239/800 CAK/W33	OH 39/800 H
	1 150	258	10 000	20 000	1 160	280	480	1 200	* 230/800 CAK/W33	OH 30/800 H
	1 280	375	14 800	31 500	1 800	200	400	2 430	231/800 CAK/W33	OH 31/800 H
800	1 120	200	6 950	15 600	930	280	480	950	* 239/850 CAK/W33	OH 39/850 H
	1 220	272	9 370	21 600	1 270	240	450	1 390	230/850 CAK/W33	OH 30/850 H
	1 360	400	16 100	34 500	2 000	180	360	2 800	231/850 CAK/W33	OH 31/850 H
850	1 180	206	7 500	17 000	1 020	260	450	930	* 239/900 CAK/W33	OH 39/900 H
	1 280	280	10 100	23 200	1 340	220	400	1 580	230/900 CAK/W33	OH 30/900 H
900	1 250	224	7 250	19 600	1 120	220	430	1 120	239/950 CAK/W33	OH 39/950 H
	1 360	300	12 000	28 500	1 600	200	380	1 870	230/950 CAK/W33	OH 30/950 H
950	1 420	308	12 700	30 500	1 700	180	360	2 070	230/1000 CAKF/W33	OH 30/1000 H
	1 580	462	21 400	48 000	2 550	140	280	4 340	231/1000 CAKF/W33	OH 31/1000 H
1 000	1 400	250	9 550	26 000	1 460	180	360	1 590	239/1060 CAKF/W33	OH 39/1060 H
	1 500	325	13 800	34 000	1 830	170	320	2 800	230/1060 CAKF/W33	OH 30/1060 H

* SKF Explorer bearing

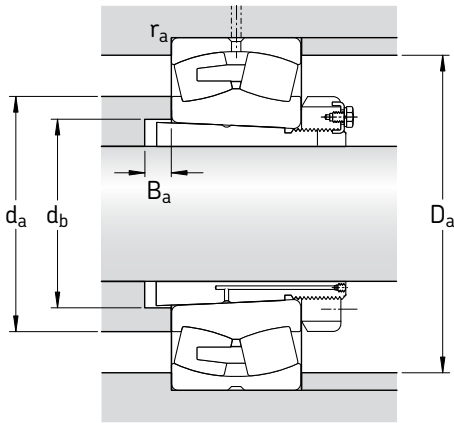

Dimensions										Abutment and fillet dimensions					Calculation factors			
d ₁	d ₂	d ₃	D ₁	B ₁	B ₂	B ₃	b	K	r _{1,2} min	d _a max	d _b min	D _a max	B _a min	r _a max	e	Y ₁	Y ₂	Y ₀
mm										mm					-			
670	788	830	882	286	90	112	22,3	12	6	788	732	927	26	5	0,17	4	5,9	4
	814	830	941	342	90	112	22,3	12	7,5	814	736	1002	26	6	0,21	3,2	4,8	3,2
	850	900	1017	467	106	135	22,3	12	9,5	850	745	1110	26	8	0,28	2,4	3,6	2,5
	875	900	1097	572	106	135	22,3	12	12	875	753	1232	26	10	0,35	1,9	2,9	1,8
710	832	870	930	291	90	112	22,3	12	6	832	772	977	26	5	0,16	4,2	6,3	4
	860	870	998	356	90	112	22,3	12	7,5	860	778	1062	26	6	0,21	3,2	4,8	3,2
	900	950	1080	493	112	141	22,3	12	9,5	900	787	1180	26	8	0,28	2,4	3,6	2,5
	938	950	1163	603	112	141	22,3	12	15	938	795	1302	26	12	0,35	1,9	2,9	1,8
750	885	920	986	303	90	112	22,3	12	6	885	822	1037	28	5	0,16	4,2	6,3	4
	915	920	1053	366	90	112	22,3	12	7,5	915	829	1122	28	6	0,20	3,4	5	3,2
	950	1000	1141	505	112	141	22,3	12	9,5	950	838	1240	28	8	0,28	2,4	3,6	2,5
800	940	980	1046	308	90	115	22,3	12	6	940	872	1097	28	5	0,16	4,2	6,3	4
	969	980	1117	380	90	115	22,3	12	7,5	969	880	1192	28	6	0,20	3,4	5	3,2
	1010	1060	1205	536	118	147	22,3	12	12	1010	890	1312	28	10	0,28	2,4	3,6	2,5
850	989	1030	1101	326	100	125	22,3	12	6	989	924	1157	30	5	0,15	4,5	6,7	4,5
	1023	1030	1176	400	100	125	22,3	12	7,5	1023	931	1252	30	6	0,20	3,4	5	3,2
900	1049	1080	1164	344	100	125	22,3	12	7,5	1049	976	1222	30	6	0,15	4,5	6,7	4,5
	1083	1080	1246	420	100	125	22,3	12	7,5	1083	983	1332	30	6	0,20	3,4	5	3,2
950	1139	1140	1305	430	100	125	22,3	12	7,5	1139	1034	1392	33	6	0,19	3,6	5,3	3,6
	1182	1240	1403	609	125	154	22,3	12	12	1182	1047	1532	33	10	0,28	2,4	3,6	2,5
1 000	1171	1200	1305	372	100	125	22,3	12	7,5	1171	1087	1372	33	6	0,16	4,2	6,3	4
	1202	1200	1378	447	100	125	22,3	12	9,5	1202	1096	1466	33	8	0,19	3,6	5,3	3,6

Spherical roller bearings on withdrawal sleeve

d_1 35 – 80 mm

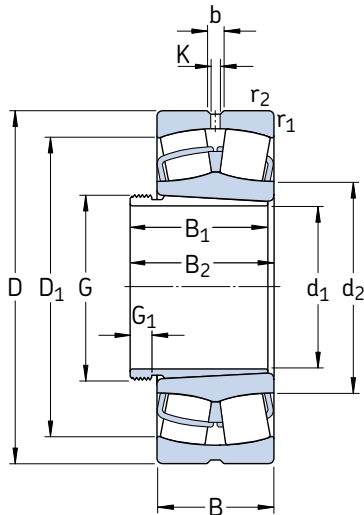

Principal dimensions			Basic load ratings		Fatigue load limit P_u	Speed ratings		Mass Bearing + sleeve	Designations Bearing	Withdrawal sleeve
d_1	D	B	C	C_0		Reference speed	Limiting speed			
mm			kN		kN	r/min		kg	–	
35	80	23	96,5	90	9,8	8 000	11 000	0,60	* 22208 EK	AH 308
	90	23	104	108	11,8	7 000	9 500	0,84	* 21308 EK	AH 308
	90	33	150	140	15	6 000	8 000	1,20	* 22308 EK	AH 2308
40	85	23	102	98	10,8	7 500	10 000	0,70	* 22209 EK	AH 309
	100	25	125	127	13,7	6 300	8 500	1,10	* 21309 EK	AH 309
	100	36	183	183	19,6	5 300	7 000	1,55	* 22309 EK	AH 2309
45	90	23	104	108	11,8	7 000	9 500	0,74	* 22210 EK	AHX 310
	110	27	156	166	18,6	5 600	7 500	1,45	* 21310 EK	AHX 310
	110	40	220	224	24	4 800	6 300	2,10	* 22310 EK	AHX 2310
50	100	25	125	127	13,7	6 300	8 500	0,95	* 22211 EK	AHX 311
	120	29	156	166	18,6	5 600	7 500	1,80	* 21311 EK	AHX 311
	120	43	270	280	30	4 300	5 600	2,70	* 22311 EK	AHX 2311
55	110	28	156	166	18,6	5 600	7 500	1,30	* 22212 EK	AHX 312
	130	31	212	240	26,5	4 800	6 300	2,20	* 21312 EK	AHX 312
	130	46	310	335	36,5	4 000	5 300	3,30	* 22312 EK	AHX 2312
60	120	31	193	216	24	5 000	7 000	1,70	* 22213 EK	AH 313 G
	140	33	236	270	29	4 300	6 000	2,75	* 21313 EK	AH 313 G
	140	48	340	360	38	3 800	5 000	4,10	* 22313 EK	AH 2313 G
65	125	31	208	228	25,5	5 000	6 700	1,80	* 22214 EK	AH 314 G
	150	35	285	325	34,5	4 000	5 600	3,35	* 21314 EK	AH 314 G
	150	51	400	430	45	3 400	4 500	4,90	* 22314 EK	AHX 2314 G
70	130	31	212	240	26,5	4 800	6 300	1,95	* 22215 EK	AH 315 G
	160	37	285	325	34,5	4 000	5 600	4,15	* 21315 EK	AH 315 G
	160	55	440	475	48	3 200	4 300	6,00	* 22315 EK	AHX 2315 G
75	140	33	236	270	29	4 300	6 000	2,40	* 22216 EK	AH 316
	170	39	325	375	39	3 800	5 300	4,75	* 21316 EK	AH 316
	170	58	490	540	54	3 000	4 000	7,00	* 22316 EK	AHX 2316
80	150	36	285	325	34,5	4 000	5 600	3,05	* 22217 EK	AHX 317
	180	41	325	375	39	3 800	5 300	5,55	* 21317 EK	AHX 317
	180	60	550	620	61	2 800	3 800	8,15	* 22317 EK	AHX 2317

* SKF Explorer bearing

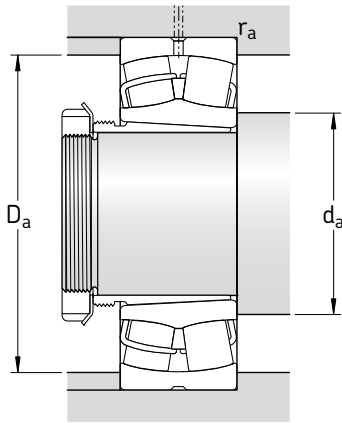

Dimensions										Abutment and fillet dimensions			Calculation factors			
d ₁	d ₂	D ₁	B ₁	B ₂ ¹⁾	G	G ₁	b	K	r _{1,2} min	d _a min	D _a max	r _a max	e	Y ₁	Y ₂	Y ₀
mm										mm			-			
35	49,1	69,4	29	32	M 45×1,5	6	5,5	3	1,1	47	73	1	0,28	2,4	3,6	2,5
	59,9	79,8	29	32	M 45×1,5	6	5,5	3	1,5	49	81	1,5	0,24	2,8	4,2	2,8
	49,7	74,3	40	43	M 45×1,5	7	5,5	3	1,5	49	81	1,5	0,37	1,8	2,7	1,8
40	54,4	74,4	31	34	M 50×1,5	6	5,5	3	1,1	52	78	1	0,26	2,6	3,9	2,5
	65,3	88	31	34	M 50×1,5	6	5,5	3	1,5	54	91	1,5	0,24	2,8	4,2	2,8
	56,4	83,4	44	47	M 50×1,5	7	5,5	3	1,5	54	91	1,5	0,37	1,8	2,7	1,8
45	59,9	79	35	38	M 55×2	7	5,5	3	1,1	57	83	1	0,24	2,8	4,2	2,8
	71,6	96,8	35	38	M 55×2	7	5,5	3	2	61	99	2	0,24	2,8	4,2	2,8
	62,1	91,9	50	53	M 55×2	9	5,5	3	2	61	99	2	0,37	1,8	2,7	1,8
50	65,3	88	37	40	M 60×2	7	5,5	3	1,5	64	91	1,5	0,24	2,8	4,2	2,8
	71,6	96,2	37	40	M 60×2	7	5,5	3	2	66	109	2	0,24	2,8	4,2	2,8
	70,1	102	54	57	M 60×2	10	5,5	3	2	66	109	2	0,35	1,9	2,9	1,8
55	71,6	96,5	40	43	M 65×2	8	5,5	3	1,5	69	101	1,5	0,24	2,8	4,2	2,8
	87,8	115	40	43	M 65×2	8	5,5	3	2,1	72	118	2	0,22	3	4,6	2,8
	77,9	110	58	61	M 65×2	11	8,3	4,5	2,1	72	118	2	0,35	1,9	2,9	1,8
60	77,6	106	42	45	M 70×2	8	5,5	3	1,5	74	111	1,5	0,24	2,8	4,2	2,8
	94,7	124	42	45	M 70×2	8	5,5	3	2,1	77	128	2	0,22	3	4,6	2,8
	81,6	118	61	64	M 70×2	12	8,3	4,5	2,1	77	128	2	0,35	1,9	2,9	1,8
65	83	111	43	47	M 75×2	8	5,5	3	1,5	79	116	1,5	0,23	2,9	4,4	2,8
	101	133	43	47	M 75×2	8	5,5	3	2,1	82	138	2	0,22	3	4,6	2,8
	90,3	128	64	68	M 75×2	12	8,3	4,5	2,1	82	138	2	0,33	2	3	2
70	87,8	115	45	49	M 80×2	8	5,5	3	1,5	84	121	1,5	0,22	3	4,6	2,8
	101	133	45	49	M 80×2	8	5,5	3	2,1	87	148	2	0,22	3	4,6	2,8
	92,8	135	68	72	M 80×2	12	8,3	4,5	2,1	87	148	2	0,35	1,9	2,9	1,8
75	94,7	124	48	52	M 90×2	8	5,5	3	2	91	129	2	0,22	3	4,6	2,8
	106	141	48	52	M 90×2	8	5,5	3	2,1	92	158	2	0,24	2,8	4,2	2,8
	98,3	143	71	75	M 90×2	12	8,3	4,5	2,1	92	158	2	0,35	1,9	2,9	1,8
80	101	133	52	56	M 95×2	9	5,5	3	2	96	139	2	0,22	3	4,6	2,8
	106	141	52	56	M 95×2	9	5,5	3	3	99	166	2,5	0,24	2,8	4,2	2,8
	108	154	74	78	M 95×2	13	8,3	4,5	3	99	166	2,5	0,33	2	3	2

¹⁾ Width before the sleeve is driven into the bearing bore

Spherical roller bearings on withdrawal sleeve

d_1 85 – 125 mm

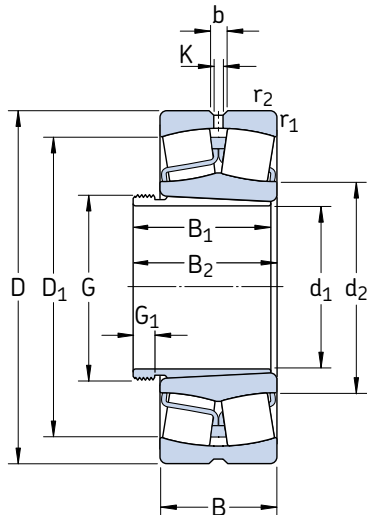

Principal dimensions			Basic load ratings		Fatigue load limit P_u	Speed ratings		Mass Bearing + sleeve	Designations Bearing	Withdrawal sleeve
d_1	D	B	C	C_0		Reference speed	Limiting speed			
mm			kN		kN	r/min		kg	–	
85	160	40	325	375	39	3 800	5 300	3,70	* 22218 EK	AHX 318
	160	52,4	355	440	48	2 800	3 800	5,00	* 23218 CCK/W33	AHX 3218
	190	43	380	450	46,5	3 600	4 800	6,40	* 21318 EK	AHX 318
	190	64	610	695	67	2 600	3 600	9,50	* 22318 EK	AHX 2318
90	170	43	380	450	46,5	3 600	4 800	4,60	* 22219 EK	AHX 319
	200	45	425	490	49	3 400	4 500	7,40	* 21319 EK	AHX 319
	200	67	670	765	73,5	2 600	3 400	11,0	* 22319 EK	AHX 2319
95	165	52	365	490	53	3 000	4 000	5,00	* 23120 CCK/W33	AHX 3120
	180	46	425	490	49	3 400	4 500	5,40	* 22220 EK	AHX 320
	180	60,3	475	600	63	2 400	3 400	7,30	* 23220 CCK/W33	AHX 3220
	215	47	425	490	49	3 400	4 500	9,10	* 21320 EK	AHX 320
	215	73	815	950	88	2 400	3 000	14,0	* 22320 EK	AHX 2320
105	170	45	310	440	46,5	3 400	4 300	4,45	* 23022 CCK/W33	AHX 322
	180	56	430	585	61	2 800	3 600	6,35	* 23122 CCK/W33	AHX 3122
	180	69	520	750	78	2 200	3 000	7,65	* 24122 CCK30/W33	AH 24122
	200	53	560	640	63	3 000	4 000	7,50	* 22222 EK	AHX 3122
	200	69,8	600	765	76,5	2 200	3 200	10,5	* 23222 CCK/W33	AHX 3222 G
	240	80	950	1 120	100	2 000	2 800	19,5	* 22322 EK	AHX 2322 G
115	180	46	355	510	53	3 200	4 000	4,80	* 23024 CCK/W33	AHX 3024
	180	60	430	670	68	2 400	3 400	5,95	* 24024 CCK30/W33	AH 24024
	200	62	510	695	71	2 600	3 400	8,70	* 23124 CCK/W33	AHX 3124
	200	80	655	950	95	1 900	2 600	10,8	* 24124 CCK30/W33	AH 24124
	215	58	630	765	73,5	2 800	3 800	9,55	* 22224 EK	AHX 3124
	215	76	695	930	93	2 000	2 800	13,0	* 23224 CCK/W33	AHX 3224 G
	260	86	965	1 120	100	2 000	2 600	24,0	* 22324 CCK/W33	AHX 2324 G
	125	200	52	430	610	62	2 800	3 600	6,75	* 23026 CCK/W33
200		69	540	815	81,5	2 000	3 000	8,65	* 24026 CCK30/W33	AH 24026
210		64	560	780	78	2 400	3 200	9,60	* 23126 CCK/W33	AHX 3126
210		80	680	1 000	100	1 800	2 400	11,7	* 24126 CCK30/W33	AH 24126
230		64	735	930	88	2 600	3 600	11,6	* 22226 EK	AHX 3126
230		80	780	1 060	104	1 900	2 600	15,5	* 23226 CCK/W33	AHX 3226 G
280		93	1 120	1 320	114	1 800	2 400	30,5	* 22326 CCK/W33	AHX 2326 G

* SKF Explorer bearing

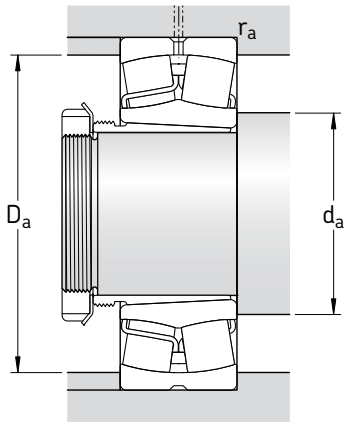

Dimensions										Abutment and fillet dimensions			Calculation factors			
d ₁	d ₂	D ₁	B ₁	B ₂ ¹⁾	G	G ₁	b	K	r _{1,2} min	d _a min	D _a max	r _a max	e	Y ₁	Y ₂	Y ₀
mm										mm			-			
85	106	141	53	57	M 100×2	9	5,5	3	2	101	149	2	0,24	2,8	4,2	2,8
	106	137	63	67	M 100×2	10	5,5	3	2	101	149	2	0,31	2,2	3,3	2,2
	112	150	53	57	M 100×2	9	8,3	4,5	3	104	176	2,5	0,24	2,8	4,2	2,8
	113	161	79	83	M 100×2	14	11,1	6	3	104	176	2,5	0,33	2	3	2
90	112	150	57	61	M 105×2	10	8,3	4,5	2,1	107	158	2	0,24	2,8	4,2	2,8
	118	159	57	61	M 105×2	10	8,3	4,5	3	109	186	2,5	0,24	2,8	4,2	2,8
	118	168	85	89	M 105×2	16	11,1	6	3	109	186	2,5	0,33	2	3	2
95	115	144	64	68	M 110×2	11	5,5	3	2	111	154	2	0,30	2,3	3,4	2,2
	118	159	59	63	M 110×2	10	8,3	4,5	2,1	112	168	2	0,24	2,8	4,2	2,8
	117	153	73	77	M 110×2	11	8,3	4,5	2,1	112	168	2	0,33	2	3	2
	118	159	59	63	M 110×2	10	8,3	4,5	3	114	201	2,5	0,24	2,8	4,2	2,8
	130	184	90	94	M 110×2	16	11,1	6	3	114	201	2,5	0,33	2	3	2
105	125	151	63	67	M 120×2	12	5,5	3	2	119	161	2	0,23	2,9	4,4	2,8
	126	157	68	72	M 120×2	11	8,3	4,5	2	121	169	2	0,30	2,3	3,4	2,2
	123	153	82	91	M 115×2	13	5,5	3	2	121	169	2	0,37	1,8	2,7	1,8
	130	178	68	72	M 120×2	11	8,3	4,5	2,1	122	188	2	0,25	2,7	4	2,5
	130	169	82	86	M 120×2	11	8,3	4,5	2,1	122	188	2	0,33	2	3	2
	143	204	98	102	M 120×2	16	13,9	7,5	3	124	226	2,5	0,33	2	3	2
115	135	163	60	64	M 130×2	13	5,5	3	2	129	171	2	0,22	3	4,6	2,8
	132	159	73	82	M 125×2	13	5,5	3	2	129	171	2	0,30	2,3	3,4	2,2
	139	174	75	79	M 130×2	12	8,3	4,5	2	131	189	2	0,28	2,4	3,6	2,5
	135	168	93	102	M 130×2	13	5,5	3	2	131	189	2	0,37	1,8	2,7	1,8
	141	189	75	79	M 130×2	12	11,1	6	2,1	132	203	2	0,26	2,6	3,9	2,5
	141	182	90	94	M 130×2	13	8,3	4,5	2,1	132	203	2	0,35	1,9	2,9	1,8
	152	216	105	109	M 130×2	17	13,9	7,5	3	134	246	2,5	0,35	1,9	2,9	1,8
	141	189	75	79	M 130×2	12	11,1	6	2,1	132	203	2	0,26	2,6	3,9	2,5
125	148	180	67	71	M 140×2	14	8,3	4,5	2	139	191	2	0,23	2,9	4,4	2,8
	145	175	83	93	M 135×2	14	5,5	3	2	139	191	2	0,31	2,2	3,3	2,2
	148	184	78	82	M 140×2	12	8,3	4,5	2	141	199	2	0,28	2,4	3,6	2,5
	146	180	94	104	M 140×2	14	5,5	3	2	141	199	2	0,35	1,9	2,9	1,8
	152	201	78	82	M 140×2	12	11,1	6	3	144	216	2,5	0,27	2,5	3,7	2,5
	151	196	98	102	M 140×2	15	8,3	4,5	3	144	216	2,5	0,33	2	3	2
	164	233	115	119	M 140×2	19	16,7	9	4	147	263	3	0,35	1,9	2,9	1,8

¹⁾ Width before the sleeve is driven into the bearing bore

Spherical roller bearings on withdrawal sleeve

d_1 135 – 170 mm

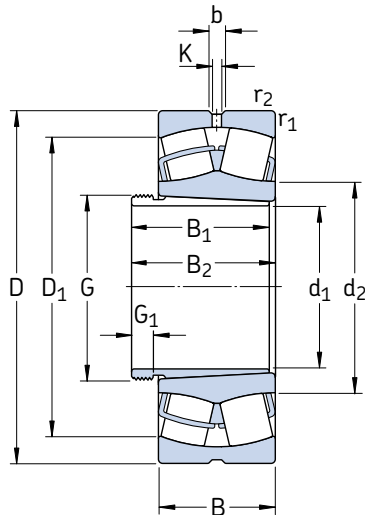

Principal dimensions			Basic load ratings		Fatigue load limit P_u	Speed ratings		Mass Bearing + sleeve	Designations Bearing	Withdrawal sleeve
d_1	D	B	C	C_0		Reference speed	Limiting speed			
mm			kN		kN	r/min		kg	–	
135	210	53	465	680	68	2 600	3 400	7,35	* 23028 CCK/W33	AHX 3028
	210	69	570	900	88	2 000	2 800	9,20	* 24028 CCK30/W33	AH 24028
	225	68	630	900	88	2 200	2 800	11,5	* 23128 CCK/W33	AHX 3128
	225	85	765	1 160	112	1 700	2 400	14,3	* 24128 CCK30/W33	AH 24128
	250	68	710	900	86,5	2 400	3 200	15,0	* 22228 CCK/W33	AHX 3128
	250	88	915	1 250	120	1 700	2 400	20,5	* 23228 CCK/W33	AHX 3228 G
	300	102	1 290	1 560	132	1 700	2 200	38,0	* 22328 CCK/W33	AHX 2328 G
145	225	56	510	750	73,5	2 400	3 200	8,85	* 23030 CCK/W33	AHX 3030
	225	75	655	1 040	100	1 800	2 600	11,3	* 24030 CCK30/W33	AH 24030
	250	80	830	1 200	114	2 000	2 600	17,0	* 23130 CCK/W33	AHX 3130 G
	250	100	1 020	1 530	146	1 500	2 200	21,0	* 24130 CCK30/W33	AH 24130
	270	73	850	1 080	102	2 200	3 000	19,0	* 22230 CCK/W33	AHX 3130 G
	270	96	1 080	1 460	137	1 600	2 200	26,0	* 23230 CCK/W33	AHX 3230 G
	320	108	1 460	1 760	146	1 600	2 000	45,5	* 22330 CCK/W33	AHX 2330 G
150	240	60	585	880	83	2 400	3 000	11,5	* 23032 CCK/W33	AH 3032
	240	80	750	1 200	114	1 700	2 400	14,8	* 24032 CCK30/W33	AH 24032
	270	86	980	1 370	129	1 900	2 400	23,0	* 23132 CCK/W33	AH 3132 G
	270	109	1 180	1 760	163	1 400	1 900	28,5	* 24132 CCK30/W33	AH 24132
	290	80	1 000	1 290	118	2 000	2 800	25,0	* 22232 CCK/W33	AH 3132 G
	290	104	1 220	1 660	153	1 500	2 200	34,5	* 23232 CCK/W33	AH 3232 G
	340	114	1 600	1 960	160	1 500	1 900	56,0	* 22332 CCK/W33	AH 2332 G
160	260	67	710	1 060	100	2 200	2 800	15,0	* 23034 CCK/W33	AH 3034
	260	90	930	1 460	137	1 600	2 400	20,0	* 24034 CCK30/W33	AH 24034
	280	88	1 040	1 500	137	1 800	2 400	25,0	* 23134 CCK/W33	AH 3134 G
	280	109	1 220	1 860	170	1 300	1 900	30,0	* 24134 CCK30/W33	AH 24134
	310	86	1 120	1 460	132	1 900	2 600	31,0	* 22234 CCK/W33	AH 3134 G
	310	110	1 400	1 930	173	1 400	2 000	41,0	* 23234 CCK/W33	AH 3234 G
	360	120	1 760	2 160	176	1 400	1 800	65,5	* 22334 CCK/W33	AH 2334 G
170	280	74	830	1 250	114	2 000	2 600	19,3	* 23036 CCK/W33	AH 3036
	280	100	1 080	1 730	156	1 500	2 200	25,7	* 24036 CCK30/W33	AH 24036
	300	96	1 200	1 760	160	1 700	2 200	32,0	* 23136 CCK/W33	AH 3136 G
	300	118	1 400	2 160	196	1 300	1 700	37,0	* 24136 CCK30/W33	AH 24136

* SKF Explorer bearing

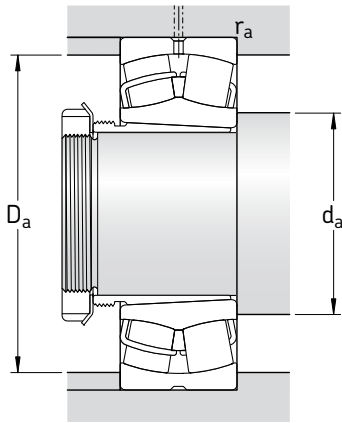

Dimensions											Abutment and fillet dimensions			Calculation factors			
d ₁	d ₂	D ₁	B ₁	B ₂ ¹⁾	G	G ₁	b	K	r _{1,2} min	d _a min	D _a max	r _a max	e	Y ₁	Y ₂	Y ₀	
mm											mm			—			
135	158	190	68	73	M 150×2	14	8,3	4,5	2	149	201	2	0,22	3	4,6	2,8	
	155	185	83	93	M 145×2	14	5,5	3	2	149	201	2	0,30	2,3	3,4	2,2	
	159	197	83	88	M 150×2	14	8,3	4,5	2,1	152	213	2	0,28	2,4	3,6	2,5	
	156	193	99	109	M 150×2	14	8,3	4,5	2,1	152	213	2	0,35	1,9	2,9	1,8	
	166	216	83	88	M 150×2	14	11,1	6	3	154	236	2,5	0,26	2,6	3,9	2,5	
	165	212	104	109	M 150×2	15	11,1	6	3	154	236	2,5	0,33	2	3	2	
	175	247	125	130	M 150×2	20	16,7	9	4	157	283	3	0,35	1,9	2,9	1,8	
145	169	203	72	77	M 160×3	15	8,3	4,5	2,1	161	214	2	0,22	3	4,6	2,8	
	165	197	90	101	M 155×3	15	5,5	3	2,1	161	214	2	0,30	2,3	3,4	2,2	
	172	216	96	101	M 160×3	15	11,1	6	2,1	162	238	2	0,30	2,3	3,4	2,2	
	169	211	115	126	M 160×3	15	8,3	4,5	2,1	162	238	2	0,37	1,8	2,7	1,8	
	178	234	96	101	M 160×3	15	13,9	7,5	3	164	256	2,5	0,26	2,6	3,9	2,5	
	175	228	114	119	M 160×3	17	11,1	6	3	164	256	2,5	0,35	1,9	2,9	1,8	
	188	266	135	140	M 160×3	24	16,7	9	4	167	303	3	0,35	1,9	2,9	1,8	
150	180	217	77	82	M 170×3	16	11,1	6	2,1	171	229	2	0,22	3	4,6	2,8	
	176	211	95	106	M 170×3	15	8,3	4,5	2,1	171	229	2	0,30	2,3	3,4	2,2	
	184	234	103	108	M 170×3	16	13,9	7,5	2,1	172	258	2	0,30	2,3	3,4	2,2	
	181	228	124	135	M 170×3	15	8,3	4,5	2,1	172	258	2	0,40	1,7	2,5	1,6	
	191	250	103	108	M 170×3	16	13,9	7,5	3	174	276	2,5	0,26	2,6	3,9	2,5	
	188	244	124	130	M 170×3	20	13,9	7,5	3	174	276	2,5	0,35	1,9	2,9	1,8	
	200	282	140	146	M 170×3	24	16,7	9	4	177	323	3	0,35	1,9	2,9	1,8	
160	191	232	85	90	M 180×3	17	11,1	6	2,1	181	249	2	0,23	2,9	4,4	2,8	
	188	226	106	117	M 180×3	16	8,3	4,5	2,1	181	249	2	0,33	2	3	2	
	195	244	104	109	M 180×3	16	13,9	7,5	2,1	182	268	2	0,30	2,3	3,4	2,2	
	190	237	125	136	M 180×3	16	8,3	4,5	2,1	182	268	2	0,37	1,8	2,7	1,8	
	203	267	104	109	M 180×3	16	16,7	9	4	187	293	3	0,27	2,5	3,7	2,5	
	200	261	134	140	M 180×3	24	13,9	7,5	4	187	293	3	0,35	1,9	2,9	1,8	
	213	300	146	152	M 180×3	24	16,7	9	4	187	343	3	0,33	2	3	2	
170	204	249	92	98	M 190×3	17	13,9	7,5	2,1	191	269	2	0,24	2,8	4,2	2,8	
	201	243	116	127	M 190×3	16	8,3	4,5	2,1	191	269	2	0,33	2	3	2	
	207	259	116	122	M 190×3	19	13,9	7,5	3	194	286	2,5	0,30	2,3	3,4	2,2	
	203	253	134	145	M 190×3	16	11,1	6	3	194	286	2,5	0,37	1,8	2,7	1,8	

¹⁾ Width before the sleeve is driven into the bearing bore

**Spherical roller bearings
on withdrawal sleeve**
d₁ 170 – 220 mm

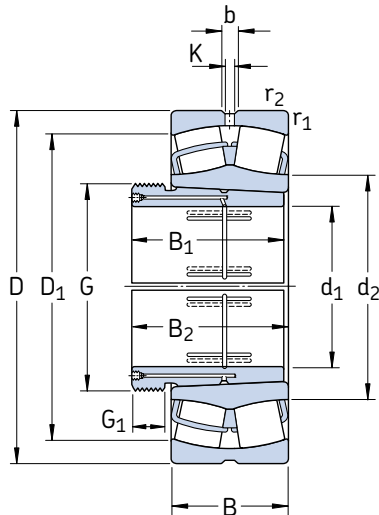

Principal dimensions			Basic load ratings		Fatigue load limit P _u	Speed ratings		Mass Bearing + sleeve	Designations Bearing	Withdrawal sleeve
d ₁	D	B	C	C ₀		Reference speed	Limiting speed			
mm			kN		kN	r/min		kg	–	
170 cont.	320	86	1 180	1 560	140	1 800	2 600	32,5	* 22236 CCK/W33	AH 2236 G
	320	112	1 500	2 120	186	1 300	1 900	43,5	* 23236 CCK/W33	AH 3236 G
	380	126	2 000	2 450	193	1 300	1 700	76,0	* 22336 CCK/W33	AH 2336 G
180	290	75	865	1 340	122	1 900	2 400	21,0	* 23038 CCK/W33	AH 3038 G
	290	100	1 120	1 800	163	1 400	2 000	27,5	* 24038 CCK30/W33	AH 24038
	320	104	1 370	2 080	183	1 500	2 000	38,5	* 23138 CCK/W33	AH 3138 G
	320	128	1 600	2 500	212	1 200	1 600	46,5	* 24138 CCK30/W33	AH 24138
	340	92	1 270	1 700	150	1 700	2 400	39,5	* 22238 CCK/W33	AH 2238 G
	340	120	1 660	2 400	208	1 300	1 800	52,5	* 23238 CCK/W33	AH 3238 G
	400	132	2 120	2 650	208	1 200	1 600	87,5	* 22338 CCK/W33	AH 2338 G
190	310	82	1 000	1 530	137	1 800	2 200	26,3	* 23040 CCK/W33	AH 3040 G
	310	109	1 290	2 120	186	1 300	1 900	34,5	* 24040 CCK30/W33	AH 24040
	340	112	1 600	2 360	204	1 500	1 900	48,5	* 23140 CCK/W33	AH 3140
	340	140	1 800	2 800	232	1 100	1 500	57,5	* 24140 CCK30/W33	AH 24140
	360	98	1 460	1 930	166	1 600	2 200	47,0	* 22240 CCK/W33	AH 2240
	360	128	1 860	2 700	228	1 200	1 700	63,0	* 23240 CCK/W33	AH 3240
	420	138	2 320	2 900	224	1 200	1 500	100	* 22340 CCK/W33	AH 2340
200	340	90	1 220	1 860	163	1 600	2 000	36,5	* 23044 CCK/W33	AOH 3044 G
	340	118	1 560	2 600	212	1 200	1 700	47,5	* 24044 CCK30/W33	AOH 24044
	370	120	1 800	2 750	232	1 300	1 700	61,5	* 23144 CCK/W33	AOH 3144
	370	150	2 120	3 350	285	1 000	1 400	76,0	* 24144 CCK30/W33	AOH 24144
	400	108	1 760	2 360	196	1 500	2 000	68,0	* 22244 CCK/W33	AOH 2244
	400	144	2 360	3 450	285	1 100	1 500	93,0	* 23244 CCK/W33	AOH 2344
	460	145	2 700	3 450	260	1 000	1 400	130	* 22344 CCK/W33	AOH 2344
220	360	92	1 290	2 080	176	1 500	1 900	40,5	* 23048 CCK/W33	AOH 3048
	360	118	1 600	2 700	228	1 100	1 600	50,5	* 24048 CCK30/W33	AOH 24048
	400	128	2 080	3 200	255	1 200	1 600	76,5	* 23148 CCK/W33	AOH 3148
	400	160	2 400	3 900	320	900	1 300	91,5	* 24148 CCK30/W33	AOH 24148
	440	120	2 200	3 000	245	1 300	1 800	95,0	* 22248 CCK/W33	AOH 2248
	440	160	2 900	4 300	345	950	1 300	120	* 23248 CCK/W33	AOH 2348
	500	155	3 100	4 000	290	950	1 300	165	* 22348 CCK/W33	AOH 2348

* SKF Explorer bearing

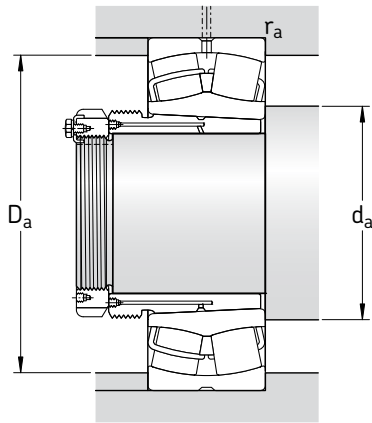

Dimensions											Abutment and fillet dimensions			Calculation factors			
d ₁	d ₂	D ₁	B ₁	B ₂ ¹⁾	G	G ₁	b	K	r _{1,2} min	d _a min	D _a max	r _a max	e	Y ₁	Y ₂	Y ₀	
mm											mm			-			
170 cont.	213	278	105	110	M 190×3	17	16,7	9	4	197	303	3	0,26	2,6	3,9	2,5	
	211	271	140	146	M 190×3	24	13,9	7,5	4	197	303	3	0,35	1,9	2,9	1,8	
	224	317	154	160	M 190×3	26	22,3	12	4	197	363	3	0,35	1,9	2,9	1,8	
180	216	261	96	102	M 200×3	18	13,9	7,5	2,1	201	279	2	0,23	2,9	4,4	2,8	
	210	253	118	131	M 200×3	18	8,3	4,5	2,1	201	279	2	0,31	2,2	3,3	2,2	
	220	275	125	131	M 200×3	20	13,9	7,5	3	204	306	2,5	0,31	2,2	3,3	2,2	
	215	268	146	159	M 200×3	18	11,1	6	3	204	306	2,5	0,40	1,7	2,5	1,6	
	225	294	112	117	M 200×3	18	16,7	9	4	207	323	3	0,26	2,6	3,9	2,5	
	222	287	145	152	M 200×3	25	16,7	9	4	207	323	3	0,35	1,9	2,9	1,8	
236	333	160	167	M 200×3	26	22,3	12	5	210	380	4	0,35	1,9	2,9	1,8		
190	228	278	102	108	Tr 210×4	19	13,9	7,5	2,1	211	299	2	0,24	2,8	4,2	2,8	
	223	268	127	140	Tr 210×4	18	11,1	6	2,1	211	299	2	0,33	2	3	2	
	231	293	134	140	Tr 220×4	21	16,7	9	3	214	326	2,5	0,31	2,2	3,3	2,2	
	226	284	158	171	Tr 210×4	18	11,1	6	3	214	326	2,5	0,40	1,7	2,5	1,6	
	238	313	118	123	Tr 220×4	21	16,7	9	4	217	343	3	0,26	2,6	3,9	2,5	
	235	304	153	160	Tr 220×4	25	16,7	9	4	217	343	3	0,35	1,9	2,9	1,8	
248	351	170	177	Tr 220×4	30	22,3	12	5	220	400	4	0,33	2	3	2		
200	250	306	111	117	Tr 230×4	20	13,9	7,5	3	233	327	2,5	0,24	2,8	4,2	2,8	
	244	295	138	152	Tr 230×4	20	11,1	6	3	233	327	2,5	0,33	2	3	2	
	255	320	145	151	Tr 240×4	23	16,7	9	4	237	353	3	0,30	2,3	3,4	2,2	
	248	310	170	184	Tr 230×4	20	11,1	6	4	237	353	3	0,40	1,7	2,5	1,6	
	263	346	130	136	Tr 240×4	20	16,7	9	4	237	383	3	0,27	2,5	3,7	2,5	
	259	338	181	189	Tr 240×4	30	16,7	9	4	237	383	3	0,35	1,9	2,9	1,8	
279	389	181	189	Tr 240×4	30	22,3	12	5	240	440	4	0,31	2,2	3,3	2,2		
220	271	326	116	123	Tr 260×4	21	13,9	7,5	3	253	347	2,5	0,23	2,9	4,4	2,8	
	265	316	138	153	Tr 250×4	20	11,1	6	3	253	347	2,5	0,30	2,3	3,4	2,2	
	277	348	154	161	Tr 260×4	25	16,7	9	4	257	383	3	0,30	2,3	3,4	2,2	
	271	336	180	195	Tr 260×4	20	11,1	6	4	257	383	3	0,40	1,7	2,5	1,6	
	290	383	144	150	Tr 260×4	21	22,3	12	4	257	423	3	0,27	2,5	3,7	2,5	
	286	374	189	197	Tr 260×4	30	22,3	12	4	257	423	3	0,35	1,9	2,9	1,8	
303	423	189	197	Tr 260×4	30	22,3	12	5	260	480	4	0,31	2,2	3,3	2,2		

¹⁾ Width before the sleeve is driven into the bearing bore

Spherical roller bearings on withdrawal sleeve

d_1 240 – 320 mm

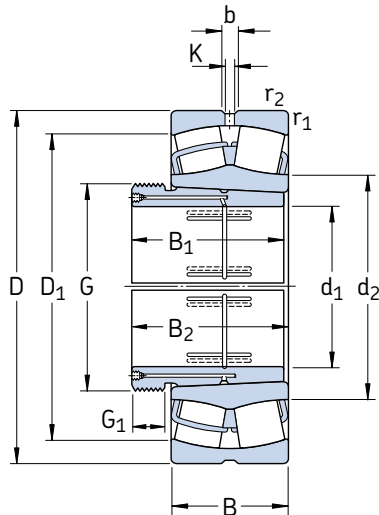

Principal dimensions			Basic load ratings		Fatigue load limit P_u	Speed ratings		Mass Bearing + sleeve	Designations Bearing	Withdrawal sleeve
d_1	D	B	C	C_0		Reference speed	Limiting speed			
mm			kN		kN	r/min		kg	–	
240	400	104	1 600	2 550	212	1 300	1 700	56,5	* 23052 CCK/W33	AOH 3052
	400	140	2 040	3 450	285	1 000	1 400	75,0	* 24052 CCK30/W33	AOH 24052 G
	440	144	2 550	3 900	290	1 100	1 400	105	* 23152 CCK/W33	AOH 3152 G
	440	180	3 000	4 800	380	850	1 200	120	* 24152 CCK30/W33	AOH 24152
	480	130	2 650	3 550	285	1 200	1 600	120	* 22252 CCK/W33	AOH 2252 G
	480	174	3 250	4 750	360	850	1 200	155	* 23252 CCK/W33	AOH 2352 G
260	540	165	3 550	4 550	325	850	1 100	205	* 22352 CCK/W33	AOH 2352 G
	420	106	1 730	2 850	224	1 300	1 600	62,0	* 23056 CCK/W33	AOH 3056
	420	140	2 160	3 800	285	950	1 400	79,0	* 24056 CCK30/W33	AOH 24056 G
	460	146	2 650	4 250	335	1 000	1 300	110	* 23156 CCK/W33	AOH 3156 G
	460	180	3 100	5 100	415	800	1 100	130	* 24156 CCK30/W33	AOH 24156
	500	130	2 700	3 750	300	1 100	1 500	125	* 22256 CCK/W33	AOH 2256 G
280	500	176	3 250	4 900	365	800	1 100	160	* 23256 CCK/W33	AOH 2356 G
	580	175	4 000	5 200	365	800	1 100	245	* 22356 CCK/W33	AOH 2356 G
	460	118	2 120	3 450	265	1 200	1 500	82,5	* 23060 CCK/W33	AOH 3060
	460	160	2 700	4 750	355	850	1 200	110	* 24060 CCK30/W33	AOH 24060 G
	500	160	3 200	5 100	380	950	1 200	140	* 23160 CCK/W33	AOH 3160 G
	500	200	3 750	6 300	465	700	1 000	180	* 24160 CCK30/W33	AOH 24160
300	540	140	3 150	4 250	325	1 000	1 400	155	* 22260 CCK/W33	AOH 2260 G
	540	192	3 900	5 850	425	750	1 000	200	* 23260 CCK/W33	AOH 3260 G
	480	121	2 240	3 800	285	1 100	1 400	89,0	* 23064 CCK/W33	AOH 3064 G
	480	160	2 850	5 100	400	800	1 200	115	* 24064 CCK30/W33	AOH 24064 G
	540	176	3 750	6 000	440	850	1 100	175	* 23164 CCK/W33	AOH 3164 G
	540	218	4 250	7 100	510	670	900	225	* 24164 CCK30/W33	AOH 24164
320	580	150	3 600	4 900	375	950	1 300	185	* 22264 CCK/W33	AOH 2264 G
	580	208	4 400	6 700	480	700	950	250	* 23264 CCK/W33	AOH 3264 G
	520	133	2 700	4 550	335	1 000	1 300	120	* 23068 CCK/W33	AOH 3068 G
	520	180	3 450	6 200	475	750	1 100	160	* 24068 CCK30/W33	AOH 24068
320	580	190	4 250	6 800	480	800	1 000	225	* 23168 CCK/W33	AOH 3168 G
	580	243	5 300	8 650	630	600	850	295	* 24168 ECCK30J/W33	AOH 24168
	620	224	5 100	7 800	550	560	800	315	* 23268 CAK/W33	AOH 3268 G

* SKF Explorer bearing

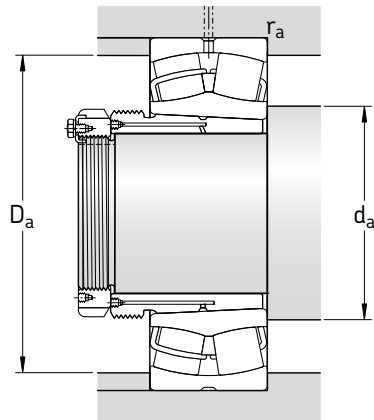

Dimensions											Abutment and fillet dimensions			Calculation factors			
d ₁	d ₂	D ₁	B ₁	B ₂ ¹⁾	G	G ₁	b	K	r _{1,2} min	d _a min	D _a max	r _a max	e	Y ₁	Y ₂	Y ₀	
mm											mm			—			
240	295	360	128	135	Tr 280×4	23	16,7	9	4	275	385	3	0,23	2,9	4,4	2,8	
	289	347	162	178	Tr 280×4	22	11,1	6	4	275	385	3	0,33	2	3	2	
	301	380	172	179	Tr 280×4	26	16,7	9	4	277	423	3	0,31	2,2	3,3	2,2	
	293	368	202	218	Tr 280×4	22	13,9	7,5	4	277	423	3	0,40	1,7	2,5	1,6	
	311	421	155	161	Tr 280×4	23	22,3	12	5	280	460	4	0,27	2,5	3,7	2,5	
260	312	408	205	213	Tr 280×4	30	22,3	12	5	280	460	4	0,35	1,9	2,9	1,8	
	328	458	205	213	Tr 280×4	30	22,3	12	6	286	514	5	0,31	2,2	3,3	2,2	
	315	380	131	139	Tr 300×4	24	16,7	9	4	295	405	3	0,23	2,9	4,4	2,8	
	309	368	162	179	Tr 300×4	22	11,1	6	4	295	405	3	0,31	2,2	3,3	2,2	
	321	401	175	183	Tr 300×4	28	16,7	9	5	300	440	4	0,30	2,3	3,4	2,2	
280	314	390	202	219	Tr 300×4	22	13,9	7,5	5	300	440	4	0,40	1,7	2,5	1,6	
	333	441	155	163	Tr 300×4	24	22,3	12	5	300	480	4	0,26	2,6	3,9	2,5	
	332	429	212	220	Tr 300×4	30	22,3	12	5	300	480	4	0,35	1,9	2,9	1,8	
	354	492	212	220	Tr 300×4	30	22,3	12	6	306	554	5	0,30	2,3	3,4	2,2	
	340	414	145	153	Tr 320×5	26	16,7	9	4	315	445	3	0,23	2,9	4,4	2,8	
300	331	400	184	202	Tr 320×5	24	13,9	7,5	4	315	445	3	0,33	2	3	2	
	345	434	192	200	Tr 320×5	30	16,7	9	5	320	480	4	0,30	2,3	3,4	2,2	
	338	422	224	242	Tr 320×5	24	13,9	7,5	5	320	480	4	0,40	1,7	2,5	1,6	
	354	477	170	178	Tr 320×5	26	22,3	12	5	320	520	4	0,26	2,6	3,9	2,5	
	356	461	228	236	Tr 320×5	34	22,3	12	5	320	520	4	0,35	1,9	2,9	1,8	
320	360	434	149	157	Tr 340×5	27	16,7	9	4	335	465	3	0,23	2,9	4,4	2,8	
	354	423	184	202	Tr 340×5	24	13,9	7,5	4	335	465	3	0,31	2,2	3,3	2,2	
	370	465	209	217	Tr 340×5	31	22,3	12	5	340	520	4	0,31	2,2	3,3	2,2	
	364	455	242	260	Tr 340×5	24	16,7	9	5	340	520	4	0,40	1,7	2,5	1,6	
	379	513	180	190	Tr 340×5	27	22,3	12	5	340	560	4	0,26	2,6	3,9	2,5	
320	382	493	246	254	Tr 340×5	36	22,3	12	5	340	560	4	0,35	1,9	2,9	1,8	
	385	468	162	171	Tr 360×5	28	22,3	12	5	358	502	4	0,24	2,8	4,2	2,8	
	377	453	206	225	Tr 360×5	26	16,7	9	5	358	502	4	0,33	2	3	2	
	394	498	225	234	Tr 360×5	33	22,3	12	5	360	560	4	0,31	2,2	3,3	2,2	
	383	491	269	288	Tr 360×5	26	16,7	9	5	360	560	4	0,40	1,7	2,5	1,6	
426	528	264	273	Tr 360×5	38	22,3	12	6	366	594	5	0,35	1,9	2,9	1,8		

¹⁾ Width before the sleeve is driven into the bearing bore

Spherical roller bearings on withdrawal sleeve

d_1 340 – 440 mm

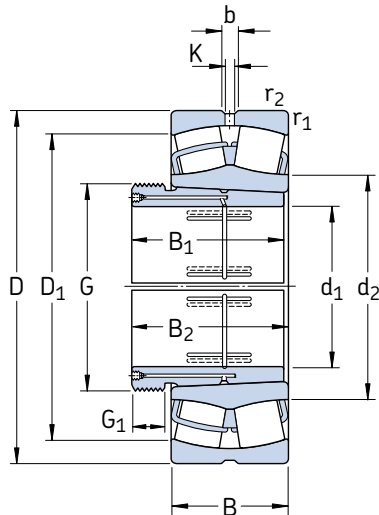

Principal dimensions			Basic load ratings		Fatigue load limit P_u	Speed ratings		Mass Bearing + sleeve	Designations Bearing	Withdrawal sleeve
d_1	D	B	C	C_0		Reference speed	Limiting speed			
mm			kN		kN	r/min		kg	–	
340	540	134	2 750	4 800	345	950	1 200	125	* 23072 CCK/W33	AOH 3072 G
	540	180	3 550	6 550	490	700	1 000	165	* 24072 CCK30/W33	AOH 24072
	600	192	4 300	6 950	490	750	1 000	235	* 23172 CCK/W33	AOH 3172 G
	600	243	5 600	9 300	670	560	800	295	* 24172 ECCK30J/W33	AOH 24172
	650	170	4 300	6 200	440	630	850	275	* 22272 CAK/W33	AOH 3172 G
	650	232	5 400	8 300	570	530	750	345	* 23272 CAK/W33	AOH 3272 G
360	560	135	2 900	5 000	360	900	1 200	135	* 23076 CCK/W33	AOH 3076 G
	560	180	3 600	6 800	480	670	950	170	* 24076 CCK30/W33	AOH 24076
	620	194	4 400	7 100	500	560	1 000	250	* 23176 CAK/W33	AOH 3176 G
	620	243	5 700	9 800	710	480	850	325	* 24176 ECAK30/W33	AOH 24176
	680	240	5 850	9 150	620	500	750	390	* 23276 CAK/W33	AOH 3276 G
	380	600	148	3 250	5 700	400	850	1 100	165	* 23080 CCK/W33
600		200	4 300	8 000	560	630	900	220	* 24080 ECCK30J/W33	AOH 24080
650		200	4 650	7 650	530	530	950	290	* 23180 CAK/W33	AOH 3180 G
650		250	6 200	10 600	735	430	800	365	* 24180 ECAK30/W33	AOH 24180
720		256	6 550	10 400	680	480	670	470	* 23280 CAK/W33	AOH 3280 G
820		243	7 500	10 400	670	430	750	675	* 22380 CAK/W33	AOH 3280 G
400	620	150	3 400	6 000	415	600	1 100	175	* 23084 CAK/W33	AOH 3084 G
	620	200	4 400	8 300	585	530	900	230	* 24084 ECAK30/W33	AOH 24084
	700	224	5 600	9 300	620	480	900	375	* 23184 CKJ/W33	AOH 3184 G
	700	280	7 350	12 600	850	400	700	470	* 24184 ECAK30/W33	AOH 24184
	760	272	7 350	11 600	765	450	630	550	* 23284 CAK/W33	AOH 3284 G
	420	650	157	3 650	6 550	450	560	1 000	200	* 23088 CAK/W33
650		212	4 800	9 150	630	500	850	275	* 24088 ECAK30/W33	AOH 24088
720		226	6 000	10 000	670	450	850	380	* 23188 CAK/W33	AOHX 3188 G
720		280	7 500	13 200	900	400	700	490	* 24188 ECAK30/W33	AOH 24188
790		280	7 800	12 500	800	430	600	620	* 23288 CAK/W33	AOHX 3288 G
440		680	163	3 900	6 950	465	560	950	225	* 23092 CAK/W33
	680	218	5 200	10 000	670	480	800	300	* 24092 ECAK30/W33	AOH 24092
	760	240	6 400	10 800	680	430	800	465	* 23192 CAK/W33	AOHX 3192 G
	760	300	8 300	14 600	1 000	360	670	590	* 24192 ECAK30/W33	AOH 24192
	830	296	8 500	13 700	880	400	560	725	* 23292 CAK/W33	AOHX 3292 G

* SKF Explorer bearing

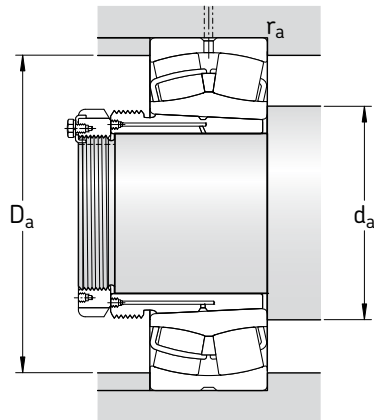

Dimensions											Abutment and fillet dimensions			Calculation factors			
d ₁	d ₂	D ₁	B ₁	B ₂ ¹⁾	G	G ₁	b	K	r _{1,2} min	d _a min	D _a max	r _a max	e	Y ₁	Y ₂	Y ₀	
mm											mm			—			
340	404	483	167	176	Tr 380x5	30	22,3	12	5	378	522	4	0,23	2,9	4,4	2,8	
	397	474	206	226	Tr 380x5	26	16,7	9	5	378	522	4	0,31	2,2	3,3	2,2	
	418	524	229	238	Tr 380x5	35	22,3	12	5	380	580	4	0,30	2,3	3,4	2,2	
	404	511	269	289	Tr 380x5	26	16,7	9	5	380	580	4	0,40	1,7	2,5	1,6	
	453	568	229	238	Tr 380x5	35	22,3	12	6	386	624	5	0,26	2,6	3,9	2,5	
	447	552	274	283	Tr 380x5	40	22,3	12	6	386	624	5	0,35	1,9	2,9	1,8	
360	426	509	170	180	Tr 400x5	31	22,3	12	5	398	542	4	0,22	3	4,6	2,8	
	419	497	208	228	Tr 400x5	28	16,7	9	5	398	542	4	0,30	2,3	3,4	2,2	
	452	541	232	242	Tr 400x5	36	22,3	12	5	400	600	4	0,30	2,3	3,4	2,2	
	442	532	271	291	Tr 400x5	28	16,7	9	5	400	600	4	0,37	1,8	2,7	1,8	
	471	581	284	294	Tr 400x5	42	22,3	12	6	406	654	5	0,35	1,9	2,9	1,8	
380	450	543	183	193	Tr 420x5	33	22,3	12	5	418	582	4	0,23	2,9	4,4	2,8	
	442	527	228	248	Tr 420x5	28	22,3	12	5	418	582	4	0,30	2,3	3,4	2,2	
	474	566	240	250	Tr 420x5	38	22,3	12	6	426	624	5	0,28	2,4	3,6	2,5	
	465	559	278	298	Tr 420x5	28	22,3	12	6	426	624	5	0,37	1,8	2,7	1,8	
	499	615	302	312	Tr 420x5	44	22,3	12	6	426	694	5	0,35	1,9	2,9	1,8	
	534	697	302	312	Tr 420x5	44	22,3	12	7,5	432	788	6	0,30	2,3	3,4	2,2	
400	485	563	186	196	Tr 440x5	34	22,3	12	5	438	602	4	0,22	3	4,6	2,8	
	476	547	230	252	Tr 440x5	30	22,3	12	5	438	602	4	0,30	2,3	3,4	2,2	
	483	607	266	276	Tr 440x5	40	22,3	12	6	446	674	5	0,30	2,3	3,4	2,2	
	494	597	310	332	Tr 440x5	30	22,3	12	6	446	674	5	0,40	1,7	2,5	1,6	
	525	649	321	331	Tr 440x5	46	22,3	12	7,5	452	728	6	0,35	1,9	2,9	1,8	
420	509	590	194	205	Tr 460x5	35	22,3	12	6	463	627	5	0,22	3	4,6	2,8	
	498	572	242	264	Tr 460x5	30	22,3	12	6	463	627	5	0,30	2,3	3,4	2,2	
	528	632	270	281	Tr 460x5	48	22,3	12	6	466	694	5	0,30	2,3	3,4	2,2	
	516	618	310	332	Tr 460x5	30	22,3	12	6	466	694	5	0,37	1,8	2,7	1,8	
	547	676	330	341	Tr 460x5	48	22,3	12	7,5	472	758	6	0,35	1,9	2,9	1,8	
440	531	617	202	213	Tr 480x5	37	22,3	12	6	483	657	5	0,22	3	4,6	2,8	
	523	601	250	273	Tr 480x5	32	22,3	12	6	483	657	5	0,28	2,4	3,6	2,5	
	553	666	285	296	Tr 480x5	43	22,3	12	7,5	492	728	6	0,30	2,3	3,4	2,2	
	544	649	332	355	Tr 480x5	32	22,3	12	7,5	492	728	6	0,37	1,8	2,7	1,8	
	572	706	349	360	Tr 480x5	50	22,3	12	7,5	492	798	6	0,35	1,9	2,9	1,8	

¹⁾ Width before the sleeve is driven into the bearing bore

Spherical roller bearings on withdrawal sleeve

d_1 460 – 630 mm

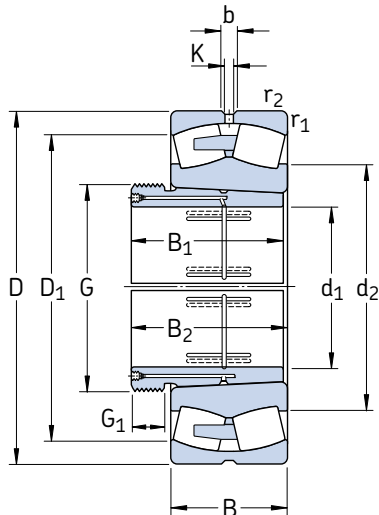

Principal dimensions			Basic load ratings		Fatigue load limit P_u	Speed ratings		Mass Bearing + sleeve	Designations Bearing	Withdrawal sleeve
d_1	D	B	C	C_0		Refer- ence speed	Limiting speed			
mm			kN		kN	r/min		kg	–	
460	700	165	3 900	6 800	450	530	950	235	* 23096 CAK/W33	AOHX 3096 G
	700	218	5 300	10 400	695	450	750	310	* 24096 ECAK30/W33	AOH 24096
	790	248	6 950	12 000	780	400	750	515	* 23196 CAK/W33	AOHX 3196 G
	790	308	9 000	15 600	1 040	340	630	635	* 24196 ECAK30/W33	AOH 24196
	870	310	9 300	15 000	950	380	530	860	* 23296 CAK/W33	AOHX 3296 G
480	720	167	4 150	7 800	510	500	900	250	* 230/500 CAK/W33	AOHX 30/500 G
	720	218	5 500	11 000	735	430	700	325	* 240/500 ECAK30/W33	AOH 240/500
	830	264	7 650	12 900	830	380	700	610	* 231/500 CAK/W33	AOHX 31/500 G
	830	325	9 800	17 000	1 120	320	600	735	* 241/500 ECAK30/W33	AOH 241/500
	920	336	10 600	17 300	1 060	360	500	1 020	* 232/500 CAK/W33	AOHX 32/500 G
500	780	185	5 100	9 300	630	450	800	360	* 230/530 CAK/W33	AOH 30/530
	780	250	6 700	13 200	830	400	670	455	* 240/530 ECAK30/W33	AOH 240/530 G
	870	272	8 150	14 000	915	360	670	715	* 231/530 CAK/W33	AOH 31/530
	870	335	10 600	19 000	1 220	300	560	885	* 241/530 ECAK30/W33	AOH 241/530 G
	980	355	11 100	20 400	1 220	300	480	1 285	232/530 CAK/W33	AOH 32/530 G
530	820	195	5 600	10 200	680	430	750	430	* 230/560 CAK/W33	AOHX 30/560
	820	258	7 350	14 600	960	380	630	515	* 240/560 ECAK30/W33	AOH 240/560 G
	920	280	9 150	16 000	980	340	630	850	* 231/560 CAK/W33	AOH 31/560
	920	355	12 000	21 600	1 340	280	500	1 060	* 241/560 ECK30J/W33	AOH 241/560 G
	1 030	365	11 500	22 000	1 400	280	430	1 500	232/560 CAK/W33	AOHX 32/560
570	870	200	6 000	11 400	750	400	700	480	* 230/600 CAK/W33	AOHX 30/600
	870	272	8 150	17 000	1 100	340	560	595	* 240/600 ECAK30/W33	AOHX 240/600
	980	300	10 200	18 000	1 100	320	560	1 010	* 231/600 CAK/W33	AOHX 31/600
	980	375	11 500	23 600	1 460	240	480	1 290	241/600 ECAK30/W33	AOHX 241/600
	1 090	388	13 100	25 500	1 560	260	400	1 760	232/600 CAK/W33	AOHX 32/600 G
600	920	212	6 700	12 500	800	380	670	575	* 230/630 CAK/W33	AOH 30/630
	920	290	8 800	18 000	1 140	320	530	730	* 240/630 ECK30J/W33	AOH 240/630 G
	1 030	315	10 500	20 800	1 220	260	530	1 190	231/630 CAK/W33	AOH 31/630
	1 030	400	12 700	27 000	1 630	220	450	1 500	241/630 ECAK30/W33	AOH 241/630 G
630	980	230	7 650	14 600	915	340	600	720	* 230/670 CAK/W33	AOH 30/670
	980	308	10 000	20 400	1 320	300	500	900	* 240/670 ECAK30/W33	AOH 240/670 G
	1 090	336	10 900	22 400	1 370	240	500	1 430	231/670 CAK/W33	AOHX 31/670
	1 090	412	13 800	29 000	1 760	200	400	1 730	241/670 ECAK30/W33	AOH 241/670
	1 220	438	15 400	30 500	1 700	220	360	2 500	232/670 CAK/W33	AOH 32/670 G

* SKF Explorer bearing

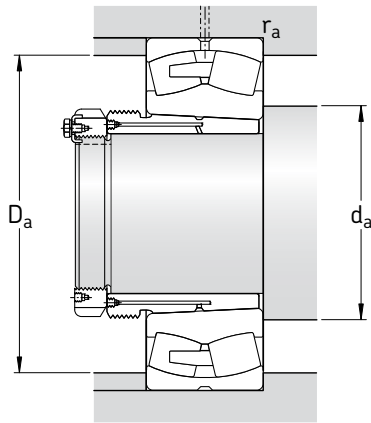

Dimensions										Abutment and fillet dimensions			Calculation factors			
d ₁	d ₂	D ₁	B ₁	B ₂ ¹⁾	G	G ₁	b	K	r _{1,2} min	d _a min	D _a max	r _a max	e	Y ₁	Y ₂	Y ₀
mm										mm			-			
460	547	633	205	217	Tr 500x5	38	22,3	12	6	503	677	5	0,21	3,2	4,8	3,2
	541	619	250	273	Tr 500x5	32	22,3	12	6	503	677	5	0,28	2,4	3,6	2,5
	577	692	295	307	Tr 500x5	45	22,3	12	7,5	512	758	6	0,30	2,3	3,4	2,2
	564	678	340	363	Tr 500x5	32	22,3	12	7,5	512	758	6	0,37	1,8	2,7	1,8
	600	741	364	376	Tr 500x5	52	22,3	12	7,5	512	838	6	0,35	1,9	2,9	1,8
480	571	658	209	221	Tr 530x6	40	22,3	12	6	523	697	5	0,21	3,2	4,8	3,2
	565	644	253	276	Tr 530x6	35	22,3	12	6	523	697	5	0,26	2,6	3,9	2,5
	603	726	313	325	Tr 530x6	47	22,3	12	7,5	532	798	6	0,30	2,3	3,4	2,2
	589	713	360	383	Tr 530x6	35	22,3	12	7,5	532	798	6	0,37	1,8	2,7	1,8
	631	779	393	405	Tr 530x6	54	22,3	12	7,5	532	888	6	0,35	1,9	2,9	1,8
500	611	710	230	242	Tr 560x6	45	22,3	12	6	553	757	5	0,22	3	4,6	2,8
	600	687	285	309	Tr 560x6	35	22,3	12	6	553	757	5	0,28	2,4	3,6	2,5
	636	763	325	337	Tr 560x6	53	22,3	12	7,5	562	838	6	0,30	2,3	3,4	2,2
	623	748	370	394	Tr 560x6	35	22,3	12	7,5	562	838	6	0,37	1,8	2,7	1,8
	668	836	412	424	Tr 560x6	57	22,3	12	9,5	570	940	8	0,35	1,9	2,9	1,8
530	644	746	240	252	Tr 600x6	45	22,3	12	6	583	797	5	0,22	3	4,6	2,8
	635	728	296	320	Tr 600x6	38	22,3	12	6	583	797	5	0,28	2,4	3,6	2,5
	673	809	335	347	Tr 600x6	55	22,3	12	7,5	592	888	6	0,30	2,3	3,4	2,2
	634	796	393	417	Tr 600x6	38	22,3	12	7,5	592	888	6	0,35	1,9	2,9	1,8
	704	878	422	434	Tr 600x6	57	22,3	12	9,5	600	990	8	0,35	1,9	2,9	1,8
570	683	789	245	259	Tr 630x6	45	22,3	12	6	623	847	5	0,22	3	4,6	2,8
	675	774	310	336	Tr 630x6	38	22,3	12	6	623	847	5	0,30	2,3	3,4	2,2
	720	863	355	369	Tr 630x6	55	22,3	12	7,5	632	948	6	0,30	2,3	3,4	2,2
	702	845	413	439	Tr 630x6	38	22,3	12	7,5	632	948	6	0,37	1,8	2,7	1,8
	752	929	445	459	Tr 630x6	57	22,3	12	9,5	640	1 050	8	0,35	1,9	2,9	1,8
600	725	839	258	272	Tr 670x6	46	22,3	12	7,5	658	892	6	0,21	3,2	4,8	3,2
	697	823	330	356	Tr 670x6	40	22,3	12	7,5	658	892	6	0,28	2,4	3,6	2,5
	755	918	375	389	Tr 670x6	60	22,3	12	7,5	662	998	6	0,30	2,3	3,4	2,2
	738	885	440	466	Tr 670x6	40	22,3	12	7,5	662	998	6	0,37	1,8	2,7	1,8
630	770	892	280	294	Tr 710x7	50	22,3	12	7,5	698	952	6	0,21	3,2	4,8	3,2
	756	866	348	374	Tr 710x7	40	22,3	12	7,5	698	952	6	0,28	2,4	3,6	2,5
	802	959	395	409	Tr 710x7	59	22,3	12	7,5	702	1 058	6	0,30	2,3	3,4	2,2
	782	942	452	478	Tr 710x7	40	22,3	12	7,5	702	1 058	6	0,37	1,8	2,7	1,8
	830	1 028	500	514	Tr 710x7	62	22,3	12	12	718	1 172	10	0,35	1,9	2,9	1,8

¹⁾ Width before the sleeve is driven into the bearing bore

Spherical roller bearings on withdrawal sleeve

d_1 670 – 1 000 mm

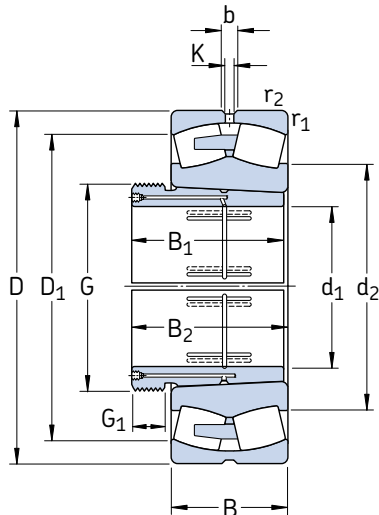

Principal dimensions			Basic load ratings		Fatigue load limit P_u	Speed ratings		Mass Bearing + sleeve	Designations Bearing	Withdrawal sleeve
d_1	D	B	C	C_0		Refer- ence speed	Limiting speed			
mm			kN		kN	r/min	kg	–		
670	1 030	236	8 300	16 300	1 000	320	560	800	* 230/710 CAK/W33	AOHX 30/710
	1 030	315	10 400	22 000	1 370	280	450	1 010	* 240/710 ECAK30/W33	AOH 240/710 G
	1 150	345	12 200	26 000	1 530	240	450	1 650	231/710 CAK/W33	AOHX 31/710
	1 150	438	15 200	32 500	1 900	190	380	2 040	241/710 ECAK30/W33	AOH 241/710
	1 280	450	17 600	34 500	2 000	200	320	2 880	232/710 CAK/W33	AOH 32/710 G
710	1 090	250	9 650	18 600	1 100	300	530	950	* 230/750 CAK/W33	AOH 30/750
	1 090	335	11 400	24 000	1 400	260	430	1 200	* 240/750 ECAK30/W33	AOH 240/750 G
	1 220	365	13 800	29 000	1 660	220	430	1 930	231/750 CAK/W33	AOH 31/750
	1 220	475	17 300	37 500	2 160	180	360	2 280	241/750 ECAK30/W33	AOH 241/750 G
	1 360	475	18 700	36 500	2 120	190	300	3 255	232/750 CAKF/W33	AOH 32/750
750	1 150	258	10 000	20 000	1 160	280	480	1 100	* 230/800 CAK/W33	AOH 30/800
	1 150	345	12 500	27 500	1 730	240	400	1 380	* 240/800 ECAK30/W33	AOH 240/800 G
	1 280	375	14 800	31 500	1 800	200	400	2 200	231/800 CAK/W33	AOH 31/800
	1 280	475	18 400	40 500	2 320	170	320	2 540	241/800 ECAK30/W33	AOH 241/800 G
800	1 220	272	9 370	21 600	1 270	240	450	1 250	230/850 CAK/W33	AOH 30/850
	1 220	365	12 700	31 500	1 900	200	360	1 670	240/850 ECAK30/W33	AOH 240/850 G
	1 360	400	16 100	34 500	2 000	180	360	2 500	231/850 CAK/W33	AOH 31/850
	1 360	500	20 200	45 000	2 550	150	300	3 050	241/850 ECAK30F/W33	AOH 241/850
850	1 280	280	10 100	23 200	1 340	220	400	1 450	230/900 CAK/W33	AOH 30/900
	1 280	375	13 600	34 500	2 040	190	340	1 850	240/900 ECAK30/W33	AOH 240/900
	1 420	515	21 400	49 000	2 700	140	280	3 700	241/900 ECAK30F/W33	AOH 241/900
900	1 360	300	12 000	28 500	1 600	200	380	1 720	230/950 CAK/W33	AOH 30/950
	1 360	412	14 800	39 000	2 320	170	300	2 300	240/950 ECAK30F/W33	AOH 240/950
	1 500	545	23 900	55 000	3 000	130	260	3 950	241/950 ECAK30F/W33	AOH 241/950
950	1 420	308	12 700	30 500	1 700	180	360	1 900	230/1000 CAKF/W33	AOH 30/1000
	1 420	412	15 400	40 500	2 240	160	280	2 500	240/1000 CAK30F/W33	AOH 240/1000
	1 580	462	21 400	48 000	2 550	140	280	3 950	231/1000 CAKF/W33	AOH 31/1000
	1 580	580	26 700	62 000	3 350	120	240	4 800	241/1000 ECAK30F/W33	AOH 241/1000
1 000	1 500	325	13 800	34 000	1 830	170	320	2 600	230/1060 CAKF/W33	AOH 30/1060
	1 500	438	17 300	45 500	2 500	150	260	2 950	240/1060 CAK30F/W33	AOH 240/1060

* SKF Explorer bearing

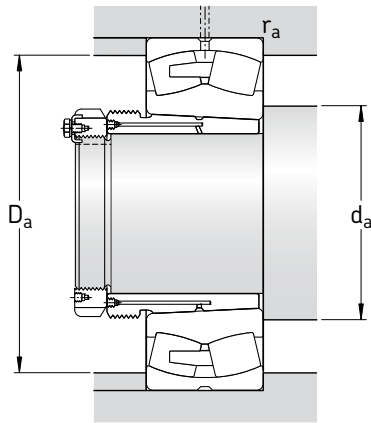

Dimensions										Abutment and fillet dimensions			Calculation factors			
d ₁	d ₂	D ₁	B ₁	B ₂ ¹⁾	G	G ₁	b	K	r _{1,2} min	d _a min	D _a max	r _a max	e	Y ₁	Y ₂	Y ₀
mm										mm			-			
670	814	941	286	302	Tr 750×7	50	22,3	12	7,5	738	1 002	6	0,21	3,2	4,8	3,2
	807	918	360	386	Tr 750×7	45	22,3	12	7,5	738	1 002	6	0,27	2,5	3,7	2,5
	850	1 017	405	421	Tr 750×7	60	22,3	12	9,5	750	1 110	8	0,28	2,4	3,6	2,5
	826	989	483	509	Tr 750×7	45	22,3	12	9,5	750	1 110	8	0,37	1,8	2,7	1,8
	875	1 097	515	531	Tr 750×7	65	22,3	12	12	758	1 232	10	0,35	1,9	2,9	1,8
710	860	998	300	316	Tr 800×7	50	22,3	12	7,5	778	1 062	6	0,21	3,2	4,8	3,2
	853	970	380	408	Tr 800×7	45	22,3	12	7,5	778	1 062	6	0,28	2,4	3,6	2,5
	900	1 080	425	441	Tr 800×7	60	22,3	12	9,5	790	1 180	8	0,28	2,4	3,6	2,5
	875	1 050	520	548	Tr 800×7	45	22,3	12	9,5	790	1 180	8	0,37	1,8	2,7	1,8
	938	1 163	540	556	Tr 800×7	65	22,3	12	15	808	1 302	12	0,35	1,9	2,9	1,8
750	915	1 053	308	326	Tr 850×7	50	22,3	12	7,5	828	1 122	6	0,20	3,4	5	3,2
	908	1 028	395	423	Tr 850×7	50	22,3	12	7,5	828	1 122	6	0,27	2,5	3,7	2,5
	950	1 141	438	456	Tr 850×7	63	22,3	12	9,5	840	1 240	8	0,28	2,4	3,6	2,5
	930	1 111	525	553	Tr 850×7	50	22,3	12	9,5	840	1 240	8	0,35	1,9	2,9	1,8
800	969	1 117	325	343	Tr 900×7	53	22,3	12	7,5	878	1 192	6	0,20	3,4	5	3,2
	954	1 088	415	445	Tr 900×7	50	22,3	12	7,5	878	1 192	6	0,27	2,5	3,7	2,5
	1 010	1 205	462	480	Tr 900×7	62	22,3	12	12	898	1 312	10	0,28	2,4	3,6	2,5
	988	1 182	560	600	Tr 900×7	60	22,3	12	12	898	1 312	10	0,35	1,9	2,9	1,8
850	1 023	1 176	335	355	Tr 950×8	55	22,3	12	7,5	928	1 252	6	0,20	3,4	5	3,2
	1 012	1 149	430	475	Tr 950×8	55	22,3	12	7,5	928	1 252	6	0,26	2,6	3,9	2,5
	1 043	1 235	575	620	Tr 950×8	60	22,3	12	12	948	1 372	10	0,35	1,9	2,9	1,8
900	1 083	1 246	355	375	Tr 1000×8	55	22,3	12	7,5	978	1 332	6	0,20	3,4	5	3,2
	1 074	1 214	467	512	Tr 1000×8	55	22,3	12	7,5	978	1 332	6	0,27	2,5	3,7	2,5
	1 102	1 305	605	650	Tr 1000×8	60	22,3	12	12	998	1 452	10	0,35	1,9	2,9	1,8
950	1 139	1 305	365	387	Tr 1060×8	57	22,3	12	7,5	1 028	1 392	6	0,19	3,6	5,3	3,6
	1 133	1 278	469	519	Tr 1060×8	57	22,3	12	7,5	1 028	1 392	6	0,26	2,6	3,9	2,5
	1 182	1 403	525	547	Tr 1060×8	63	22,3	12	12	1 048	1 532	10	0,28	2,4	3,6	2,5
	1 159	1 373	645	695	Tr 1060×8	65	22,3	12	12	1 048	1 532	10	0,35	1,9	2,9	1,8
1 000	1 202	1 378	385	407	Tr 1120×8	60	22,3	12	9,5	1 094	1 466	8	0,19	3,6	5,3	3,6
	1 196	1 349	498	548	Tr 1120×8	60	22,3	12	9,5	1 094	1 466	8	0,26	2,6	3,9	2,5

¹⁾ Width before the sleeve is driven into the bearing bore



CARB® toroidal roller bearings

Designs	780
Open bearings	780
Sealed bearings	781
Bearings for vibratory applications	781
SKF Explorer class bearings	781
Bearings on sleeves	782
Appropriate bearing housings	783
Bearing data – general	784
Dimensions	784
Tolerances	784
Internal clearance.....	784
Misalignment.....	784
Axial displacement.....	787
Influence of operating temperature on bearing material.....	790
Cages.....	790
Minimum load.....	790
Equivalent dynamic bearing load.....	791
Equivalent static bearing load.....	791
Supplementary designations.....	791
Free space on the sides of the bearing	792
Mounting	792
Mounting bearings with a tapered bore	793
Measuring the clearance reduction	793
Measuring the lock nut tightening angle.....	794
Measuring the axial drive-up.....	794
Measuring the inner ring expansion	797
Additional mounting information	797
Product tables	798
CARB toroidal roller bearings	798
Sealed CARB toroidal roller bearings	812
CARB toroidal roller bearings on adapter sleeve	816
CARB toroidal roller bearings on withdrawal sleeve.....	826



Designs

The CARB® toroidal roller bearing is a completely new type of radial roller bearing (→ **fig. 1**). This compact self-aligning roller bearing was developed by SKF and introduced on the market in 1995. In a unique design, it combines the self-aligning capability of the spherical roller bearing with the unconstrained axial displacement ability of the cylindrical roller bearing. It can also have the compact cross section normally associated with the needle roller bearing.

The applicability of CARB bearings covers a wide range with regard to radial loads. They are intended exclusively as non-locating bearings and as such they are excellent with their combination of self-aligning and axial displacement properties, opening up completely new opportunities to save space, weight and production costs. By deliberately displacing the rings axially with respect to each other, it is possible to accurately set the radial internal clearance in the bearing.

CARB bearings permit smaller and lighter bearing arrangement designs, offering the same or improved performance in a particularly impressive manner, e.g. in planetary gearboxes. They simplify the bearing arrangement design for long shafts that are subjected to temperature variations. When using CARB bearings, it has also been proven that vibration levels are reduced, e.g. in paper machines or fans.

The CARB bearing is a single row bearing with long, slightly crowned symmetrical rollers. The raceways of both the inner and outer rings are concave and situated symmetrically about the bearing centre. The attained optimal combination of both raceway profiles provides a favourable load distribution in the bearing, as well as low frictional running.

The rollers of the CARB bearing are self-guiding, i.e. they will always adopt the position where the load is evenly distributed over the roller length – irrespective of whether the inner ring is axially displaced and/or misaligned with respect to the outer ring.

The load carrying capacity of the CARB bearing is very high even when it has to compensate for angular misalignment or axial displacement. This results in an operationally reliable bearing arrangement with long service life.

Open bearings

CARB toroidal roller bearings are produced to two basic designs (→ **fig. 2**), depending on bearing size and series as

- bearings with cage (**a**)
- full complement bearings (**b**).

The load carrying capacity of the full complement CARB bearing is appreciably higher than that of the caged bearing. Both designs are available with a cylindrical bore as well as with a tapered bore. Depending on bearing series the tapered bore has a taper of either 1:12 (designation suffix K) or 1:30 (designation suffix K30).

Fig. 1

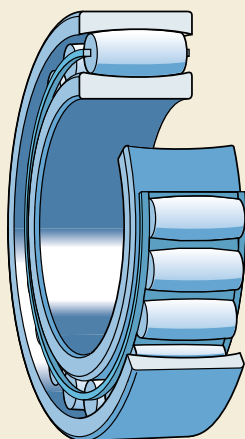

Sealed bearings

Today, the range of sealed bearings (→ **fig. 3**) consists of small and medium size full complement bearings for low speeds. These bearings with seals on both sides are filled with a grease for high temperature and long life, and they are maintenance-free.

The double lip seal, suitable for high temperature operations, is sheet steel reinforced and made of hydrogenated acrylonitrile-butadiene rubber (HNBR). It seals against the inner ring raceway. The outside diameter of the seal is retained in an outer ring recess and provides proper sealing also in applications with outer ring rotation. The seals can withstand operating temperatures in the range of -40 and $+150$ °C.

The sealed bearings are filled with a premium quality grease, with a polyurea thickener and synthetic ester base oil. This grease has good corrosion inhibiting properties and can be used at temperatures between -25 and $+180$ °C. The base oil viscosity is 440 mm²/s at 40 °C and 38 mm²/s at 100 °C. The grease fill is 70 to 100 % of the free space in the bearing. Sealed bearings with other lubricating greases or degrees of grease fill can be supplied on request.

Bearings for vibratory applications

For non-locating bearing positions in vibratory applications SKF manufactures CARB bearings with a surface hardened pressed steel cage in the C 23/C4VG114 series with a cylindrical bore. These bearings have the same dimensions and product data as the bearings in the C 23 series. They enable a press fit on the shaft to avoid possible fretting corrosion caused by a loose fit on the shaft. Using CARB bearings in vibratory applications on the non-locating side of the bearing arrangement will result in a self-aligning bearing system with better performance and reliability.

For additional information on CARB bearings in the C 23/C4VG114 series, please consult the SKF application engineering service.

SKF Explorer class bearings

All CARB bearings are manufactured to the SKF Explorer performance class.

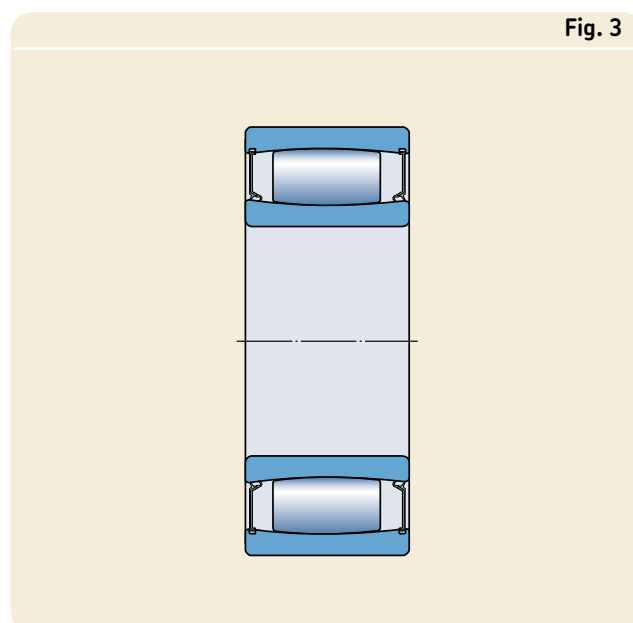
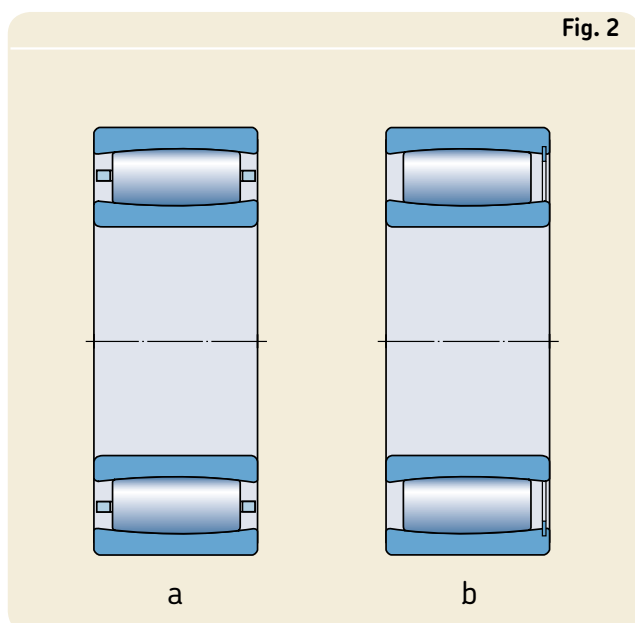

Bearings on sleeves

CARB bearings with a tapered bore can be mounted on smooth or stepped shafts using

- an adapter sleeve (→ **fig. 4**), product table starting on **page 816**
- a withdrawal sleeve (→ **fig. 5**), product table starting on **page 826**.

Where appropriate, modified adapter sleeves (→ **fig. 6**) of the E, L and TL designs are available for CARB bearings, to prevent the locking device from chafing the adjacent cage:

- With the E-design sleeve, the standard KM lock nut and MB locking washer are replaced by a KMFE nut (**a**), and the standard lock nut HM 30 is replaced by an HME 30 nut with a recess at the outside diameter (**b**).
- The L-design sleeve differs from the standard design in that the standard KM lock nut and MB locking washer have been replaced by a KML nut and MBL locking washer; implying lower sectional height (**c**).
- With the TL-design sleeve, the standard HM .. T lock nut and MB locking washer have been replaced by the corresponding HM 30 nut and MS 30 locking clip; implying lower sectional height (**d**).

Where larger axial displacements can occur, it is recommended to observe the information in the section “Free space on the sides of the bearing” on **page 792**.

Fig. 4

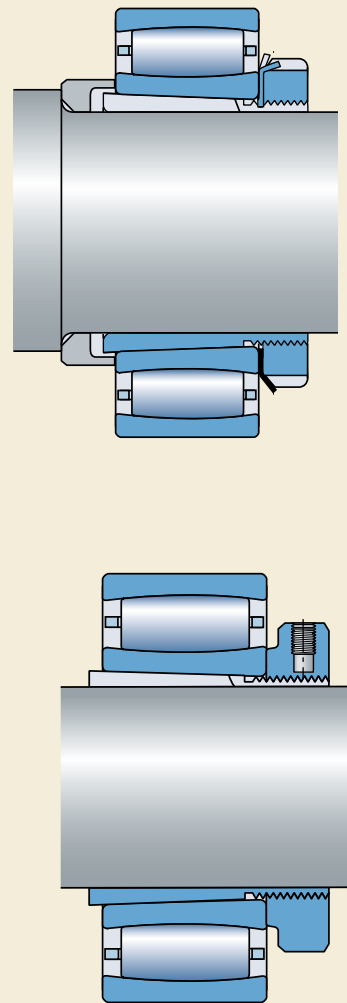

Fig. 5

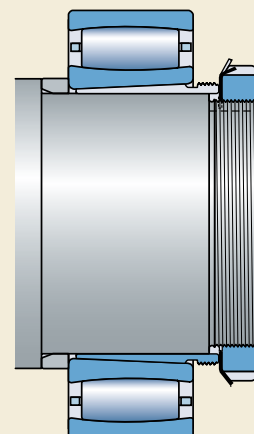
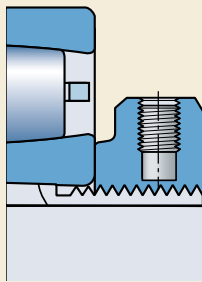
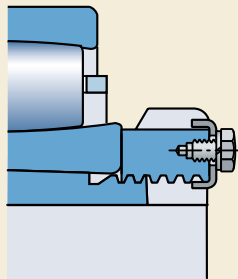

Fig. 6



a



b

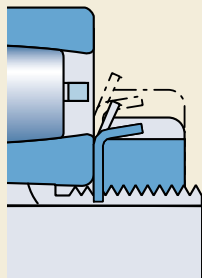

c

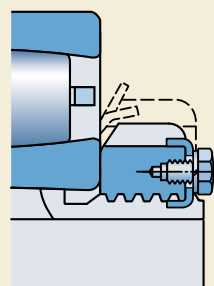

d

Appropriate bearing housings

The combination of a CARB bearing and an appropriate bearing housing constitutes an economic, interchangeable and reliable non-locating bearing arrangement, which fulfils the demands for easy maintenance. SKF standard housings are available for almost all CARB bearings of diameter series 0, 1, 2 and 3. Two bearing arrangement types are possible without requiring special measures:

- CARB bearing on an adapter sleeve and smooth shafts.
- CARB bearing on cylindrical seating and stepped shafts.

Detailed information on plummer (pillow) block housing in the SNL 2, 3, 5 and 6 series can be found in the section “Bearing housings”, starting on **page 1031**.

A brief description of all the SKF housings is also provided in the section “Bearing housings” where only main features are presented. Publications for detailed information are listed.

Bearing data – general

Dimensions

The boundary dimensions of CARB bearings are in accordance with ISO 15:1998. The dimensions of the adapter and withdrawal sleeves correspond to ISO 2982-1:1995.

Tolerances

SKF CARB bearings are manufactured as standard to Normal tolerances. Bearings up to and including 300 mm bore diameter are produced to higher precision than the ISO Normal tolerances. For example

- the width tolerance is considerably tighter than the ISO Normal tolerance; the tolerance is the same as for SKF Explorer spherical roller bearings (→ **table 2** on **page 704**)
- the running accuracy is to tolerance class P5 as standard.

For larger bearing arrangements where running accuracy is a key operational parameter, SKF CARB bearings with P5 running accuracy are also available. These bearings are identified by the suffix C08. Their availability should be checked.

The values of the tolerances are in accordance with ISO 492:2002 and can be found in **tables 3** to **5**, starting on **page 125**.

Internal clearance

CARB bearings are produced as standard with Normal radial internal clearance and most are also available with a larger C3 clearance. Many bearings can also be supplied with a smaller C2 clearance or with a much greater C4 or C5 clearance.

The radial internal clearance limits are listed for bearings with

- cylindrical bore in **table 1**
- tapered bore in **table 2**.

The limits are valid for bearings before mounting under zero measuring load, and with no axial displacement of one ring relative to the other.

Axial displacement of one ring relative to the other will gradually reduce the radial internal

clearance in a CARB bearing. The amount of axial displacement encountered in cases without external heating of the shaft or foundation will have little effect on the radial internal clearance (→ section “Axial displacement”, starting on **page 787**).

CARB bearings are often used together with spherical roller bearings. The clearance of the CARB bearing is slightly larger than that of the corresponding spherical roller bearing having the same clearance class. An axial displacement of the inner ring relative to the outer ring of 6 to 8 % of the bearing width will reduce the operational clearance to approximately the same value as a spherical roller bearing of the same size.

Misalignment

During operation, angular misalignment of up to $0,5^\circ$ between the inner and outer rings (→ **fig. 7**) can usually be accommodated by a CARB bearing without any negative consequences for the bearing. However, misalignment values greater than $0,5^\circ$ will increase friction and influence bearing service life. For misalignment greater than $0,5^\circ$ please consult the SKF application engineering service. The ability to compensate for misalignment when the bearing is stationary is also limited. For CARB bearings with a machined brass cage centred on the inner ring, designation suffix MB, misalignment should never exceed $0,5^\circ$.

Misalignment displaces the rollers axially, causing them to approach the side faces of the

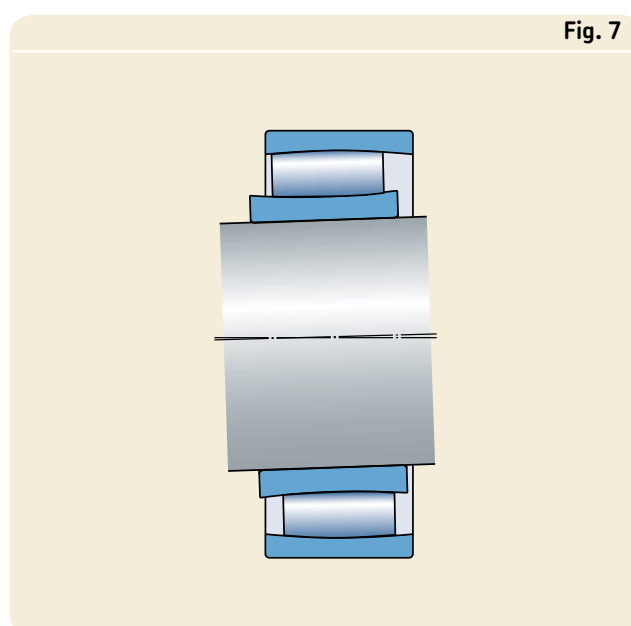
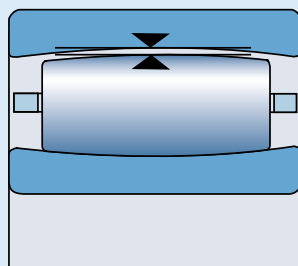

Fig. 7

Table 1

Radial internal clearance of CARB bearings with a cylindrical bore



Bore diameter d		Radial internal clearance									
over	incl.	C2		Normal		C3		C4		C5	
		min	max	min	max	min	max	min	max	min	max
mm		µm									
18	24	15	27	27	39	39	51	51	65	65	81
24	30	18	32	32	46	46	60	60	76	76	94
30	40	21	39	39	55	55	73	73	93	93	117
40	50	25	45	45	65	65	85	85	109	109	137
50	65	33	54	54	79	79	104	104	139	139	174
65	80	40	66	66	96	96	124	124	164	164	208
80	100	52	82	82	120	120	158	158	206	206	258
100	120	64	100	100	144	144	186	186	244	244	306
120	140	76	119	119	166	166	215	215	280	280	349
140	160	87	138	138	195	195	252	252	321	321	398
160	180	97	152	152	217	217	280	280	361	361	448
180	200	108	171	171	238	238	307	307	394	394	495
200	225	118	187	187	262	262	337	337	434	434	545
225	250	128	202	202	282	282	368	368	478	478	602
250	280	137	221	221	307	307	407	407	519	519	655
280	315	152	236	236	330	330	434	434	570	570	714
315	355	164	259	259	360	360	483	483	620	620	789
355	400	175	280	280	395	395	528	528	675	675	850
400	450	191	307	307	435	435	577	577	745	745	929
450	500	205	335	335	475	475	633	633	811	811	1 015
500	560	220	360	360	518	518	688	688	890	890	1 110
560	630	245	395	395	567	567	751	751	975	975	1 215
630	710	267	435	435	617	617	831	831	1 075	1 075	1 335
710	800	300	494	494	680	680	920	920	1 200	1 200	1 480
800	900	329	535	535	755	755	1 015	1 015	1 325	1 325	1 655
900	1 000	370	594	594	830	830	1 120	1 120	1 460	1 460	1 830
1 000	1 120	410	660	660	930	930	1 260	1 260	1 640	1 640	2 040
1 120	1 250	450	720	720	1 020	1 020	1 380	1 380	1 800	1 800	2 240

Please refer to page 137 for the definition of radial internal clearance

Table 2

Radial internal clearance of CARB bearings with a tapered bore

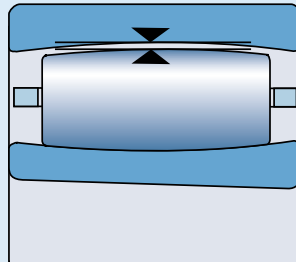

Bore diameter d		Radial internal clearance									
over	incl.	C2		Normal		C3		C4		C5	
		min	max	min	max	min	max	min	max	min	max
mm		µm									
18	24	19	31	31	43	43	55	55	69	69	85
24	30	23	37	37	51	51	65	65	81	81	99
30	40	28	46	46	62	62	80	80	100	100	124
40	50	33	53	53	73	73	93	93	117	117	145
50	65	42	63	63	88	88	113	113	148	148	183
65	80	52	78	78	108	108	136	136	176	176	220
80	100	64	96	96	132	132	172	172	218	218	272
100	120	75	115	115	155	155	201	201	255	255	321
120	140	90	135	135	180	180	231	231	294	294	365
140	160	104	155	155	212	212	269	269	338	338	415
160	180	118	173	173	238	238	301	301	382	382	469
180	200	130	193	193	260	260	329	329	416	416	517
200	225	144	213	213	288	288	363	363	460	460	571
225	250	161	235	235	315	315	401	401	511	511	635
250	280	174	258	258	344	344	444	444	556	556	692
280	315	199	283	283	377	377	481	481	617	617	761
315	355	223	318	318	419	419	542	542	679	679	848
355	400	251	350	350	471	471	598	598	751	751	920
400	450	281	383	383	525	525	653	653	835	835	1 005
450	500	305	435	435	575	575	733	733	911	911	1 115
500	560	335	475	475	633	633	803	803	1 005	1 005	1 225
560	630	380	530	530	702	702	886	886	1 110	1 110	1 350
630	710	422	590	590	772	772	986	986	1 230	1 230	1 490
710	800	480	674	674	860	860	1 100	1 100	1 380	1 380	1 660
800	900	529	735	735	955	955	1 215	1 215	1 525	1 525	1 855
900	1 000	580	814	814	1 040	1 040	1 340	1 340	1 670	1 670	2 050
1 000	1 120	645	895	895	1 165	1 165	1 495	1 495	1 875	1 875	2 275
1 120	1 250	705	975	975	1 275	1 275	1 635	1 635	2 055	2 055	2 495

Please refer to page 137 for the definition of radial internal clearance

bearing rings. Therefore, possible axial displacement should be reduced (→ section “Axial displacement”).

Axial displacement

CARB toroidal roller bearings can accommodate axial displacement of the shaft relative to the housing within the bearing. The axial displacement can result from thermal expansion or deviations from determined bearing positions.

Misalignment as well as axial displacement influences the axial position of the rollers in a CARB bearing. Axial displacement also reduces the radial clearance. SKF recommends checking that the axial displacement is within acceptable limits, i.e. the residual clearance is great enough, and that the rollers do not protrude outside the side face of a ring (→ **fig. 8a**) or contact any locking ring (→ **fig. 8b**) or seal. To accommodate the displacement of the roller and cage assembly, provide free space on both sides of the bearing as described in the section “Free space on the sides of the bearing” on **page 792**.

The axial displacement from the normal position of one bearing ring in relation to the other is limited by

- the displacement of the roller set, or by
- the reduction of clearance.

The maximum possible axial displacement is obtained from the smaller of these two limitations.

Limitation caused by the displacement of the roller set

The guideline values s_1 and s_2 for axial displacement (→ **fig. 8**) shown in the product tables are valid, provided

- there is a sufficiently large operational radial clearance in the bearing before shaft elongation, and
- the rings are not misaligned.

The reduction in the possible axial displacement caused by misalignment can be estimated using

$$s_{\text{mis}} = k_1 B \alpha$$

where

s_{mis} = reduction in axial displacement caused by misalignment, mm

k_1 = misalignment factor
(→ product tables)

B = bearing width, mm
(→ product tables)

α = misalignment, degrees

Assuming a sufficiently large operational clearance, the maximum possible axial displacement is obtained from

$$s_{\text{lim}} = s_1 - s_{\text{mis}}$$

or

$$s_{\text{lim}} = s_2 - s_{\text{mis}}$$

where

s_{lim} = possible axial displacement relative to the movement of the roller set caused by misalignment, mm

s_1 = guideline value for the axial displacement capability in bearings with a cage or in full complement bearings when displacing away from the snap ring, mm
(→ product tables)

s_2 = guideline value for the axial displacement capability in sealed or full complement bearings when displacing towards the seal or snap ring respectively, mm
(→ product tables)

s_{mis} = reduction in axial displacement caused by misalignment, mm

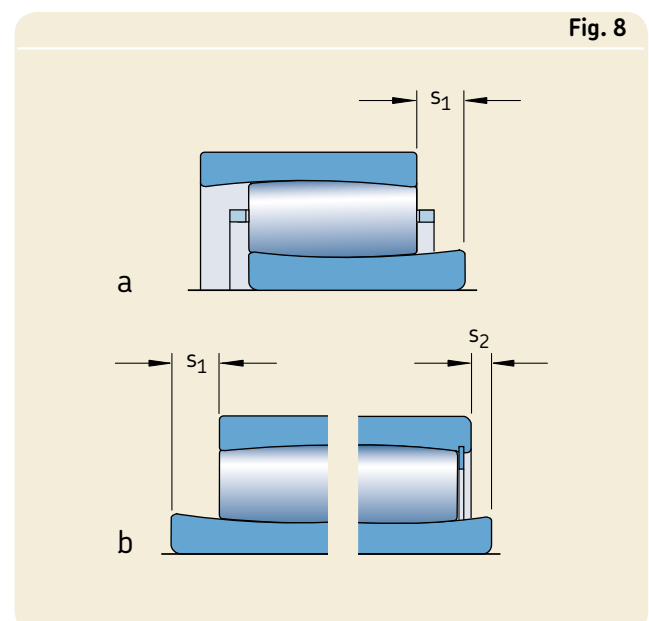

CARB toroidal roller bearings

Limitation caused by the reduction of clearance

The radial clearance reduction corresponding to axial displacement from a centred position can be calculated using

$$C_{\text{red}} = \frac{k_2 s_{\text{cle}}^2}{B}$$

In cases where the reduction of the clearance is greater than the radial clearance before shaft elongation, the bearing will be preloaded. If instead a certain radial clearance reduction is known, the corresponding axial displacement from a centred position can be calculated using

$$s_{\text{cle}} = \sqrt{\frac{B C_{\text{red}}}{k_2}}$$

where

s_{cle} = axial displacement from a centred position, corresponding to a certain radial clearance reduction, mm

C_{red} = reduction of radial clearance as a result of an axial displacement from a centred position, mm

k_2 = operating clearance factor (→ product tables)

B = bearing width, mm (→ product tables)

The axial displacement capability can also be obtained using **diagram 1**, which is valid for all CARB bearings. The axial displacement and radial clearance are shown as functions of the bearing width.

From **diagram 1** it can be seen (dotted line) that for a bearing C 3052 K/HA3C4, for an operational clearance of 0,15 mm which corresponds to approximately 0,15 % of the bearing width, an axial displacement of approximately 12 % of the bearing width is possible. Thus, when an axial displacement of approximately $0,12 \times 104 = 12,5$ mm has taken place, the operational clearance will be zero.

It should be remembered that the distance between the dotted line and the curve represents the residual radial operating clearance in the bearing arrangement.

Diagram 1 also illustrates how it is possible, simply by axially displacing the bearing rings relative to each other, to achieve a given radial internal clearance in a CARB bearing.

Calculation example 1

For bearing C 3052, having

- a width $B = 104$ mm
- a misalignment factor $k_1 = 0,122$
- a value for the axial displacement $s_1 = 19,3$,

with an angular misalignment of $\alpha = 0,3^\circ$ between the inner and outer ring, the permissible axial displacement can be obtained from

$$\begin{aligned} s_{\text{lim}} &= s_1 - s_{\text{mis}} \\ s_{\text{lim}} &= s_1 - k_1 B \alpha \\ s_{\text{lim}} &= 19,3 - 0,122 \times 104 \times 0,3 = 19,3 - 3,8 \\ s_{\text{lim}} &= 15,5 \text{ mm} \end{aligned}$$

Calculation example 2

For bearing C 3052 K/HA3C4, having

- a width $B = 104$ mm
- an operating clearance factor $k_2 = 0,096$
- an operational clearance of 0,15 mm,

the possible axial displacement from the central position of one ring to the other until the operational clearance equals zero can be obtained from

$$s_{\text{cle}} = \sqrt{\frac{B C_{\text{red}}}{k_2}}$$

$$s_{\text{cle}} = \sqrt{\frac{104 \times 0,15}{0,096}}$$

$$s_{\text{cle}} = 12,7 \text{ mm}$$

The axial displacement of 12,7 mm is below the limiting value $s_1 = 19,3$ mm, shown in the product table. An operating misalignment of $0,3^\circ$ is also permissible, see also example 1.

Calculation example 3

For bearing C 3052, which has a width $B = 104$ mm and an operating clearance factor $k_2 = 0,096$, the reduction in operational clearance caused by an axial displacement $s_{cle} = 6,5$ mm from the central position is calculated using

$$C_{red} = \frac{k_2 s_{cle}^2}{B}$$

$$C_{red} = \frac{0,096 \times 6,5^2}{104}$$

$$C_{red} = 0,039 \text{ mm}$$

Diagram 1

Axial displacement in % of the bearing width

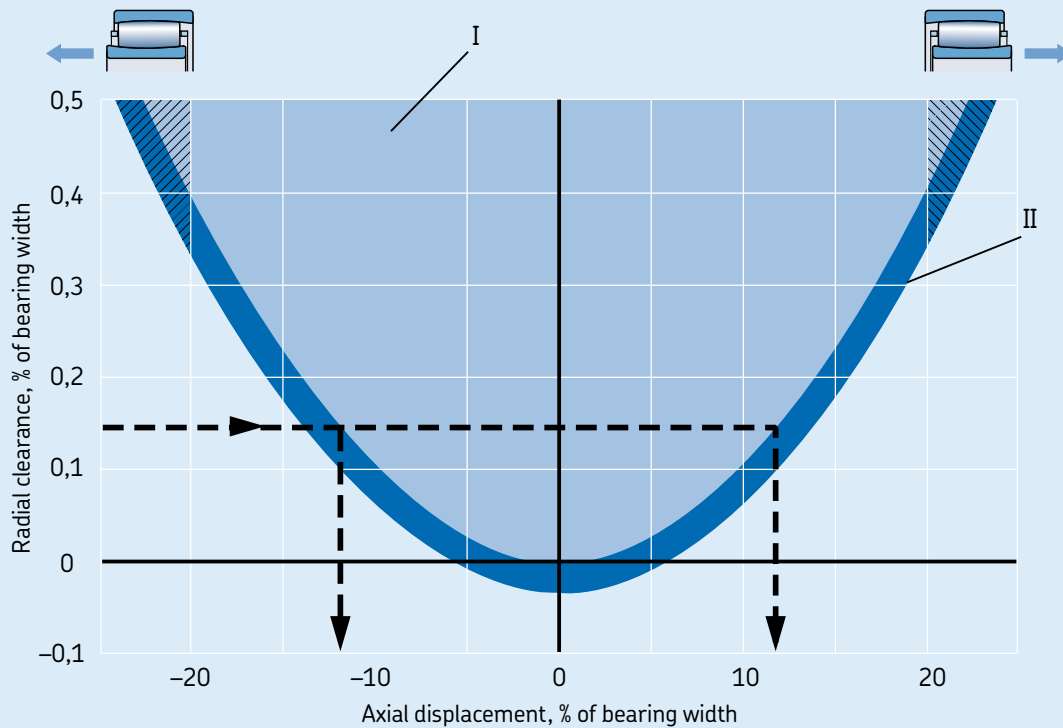

I Range of operation with operational clearance

II Possible range of operation where the bearing will have preload and the friction can increase by up to 50 % but where the L_{10} bearing life will still be achieved

Influence of operating temperature on bearing material

All CARB bearings undergo a special heat treatment so that they can be operated at higher temperatures for longer periods, without the occurrence of inadmissible dimensional changes, provided the permissible operating temperature of the cage is not exceeded, for example, a temperature of +200 °C for 2 500 h, or for short periods at even higher temperatures.

Cages

When the bearing is not of the full complement design, depending upon size, CARB bearings are fitted as standard with one of the following cages (→ **fig. 9**)

- an injection moulded window-type cage of glass fibre reinforced polyamide 4,6, roller centred, designation suffix TN9 (**a**)
- a pressed window-type steel cage, roller centred, no designation suffix (**b**)
- a machined window-type brass cage, roller centred, designation suffix M (**c**)
- a two-piece machined brass cage, inner ring centred, designation suffix MB (**d**).

Note

CARB bearings with polyamide 4,6 cages can be operated continuously at temperatures up to +130 °C. The lubricants generally used for rolling bearings do not have a detrimental effect on cage properties, with the exception of a few synthetic oils and greases with a synthetic oil base,

and lubricants containing a high proportion of EP additives when used at high temperatures.

For bearing arrangements, which are to be operated at continuously high temperatures or under arduous conditions, it is recommended to use bearings with steel or brass cage. Full complement bearings might also be a possible alternative.

For detailed information about the temperature resistance and the applicability of cages, please refer to the section “Cage materials”, starting on **page 140**.

Minimum load

In order to provide satisfactory operation, CARB bearings, like all ball and roller bearings, must always be subjected to a given minimum load, particularly if they are to operate at high speeds or are subjected to high accelerations or rapid changes in the direction of load. Under such conditions, the inertia forces of the rollers and cage, and the friction in the lubricant, can have a detrimental effect on the rolling conditions in the bearing arrangement and may cause damaging sliding movements to occur between the rollers and raceways.

The requisite minimum load to be applied to a CARB bearing with cage can be estimated using

$$F_{rm} = 0,007 C_0$$

Fig. 9

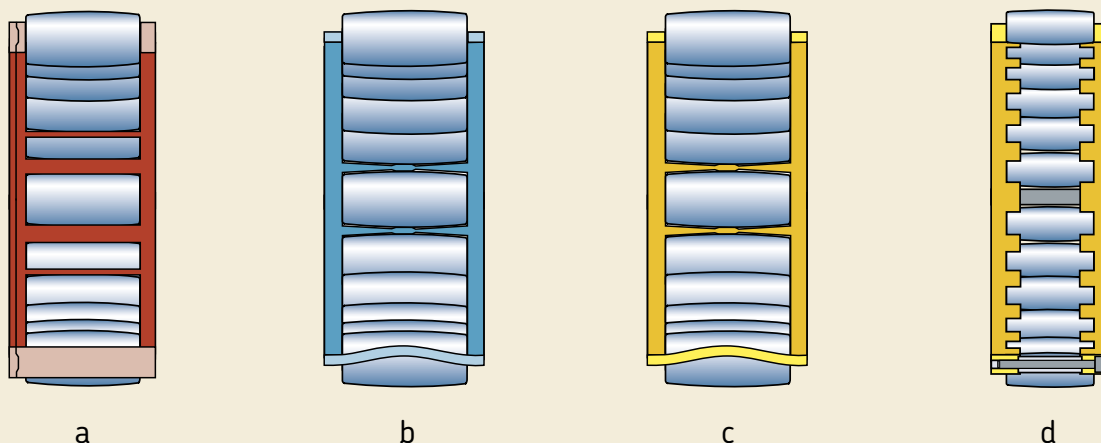

and for a full complement bearing using

$$F_{rm} = 0,01 C_0$$

where

F_{rm} = minimum radial bearing load, kN

C_0 = basic static load rating, kN
(→ product tables)

In some applications it is not possible to reach or exceed the requisite minimum load. However, for caged bearings that are oil lubricated, lower minimum loads are permissible. These loads can be calculated when $n/n_r \leq 0,3$ from

$$F_{rm} = 0,002 C_0$$

and when $0,3 < n/n_r \leq 2$ from

$$F_{rm} = 0,003 C_0 \left(1 + 2 \sqrt{\frac{n}{n_r} - 0,3} \right)$$

where

F_{rm} = minimum radial bearing load, kN

C_0 = basic static load rating, kN
(→ product tables)

n = rotational speed, r/min

n_r = reference speed, r/min
(→ product tables)

When starting up at low temperatures or when the lubricant is highly viscous, even greater minimum loads than $F_{rm} = 0,007 C_0$ and $0,01 C_0$ respectively may be required. The weight of the components supported by the bearing, together with external forces, generally exceeds the requisite minimum load. If this is not the case, the CARB bearing must be subjected to an additional radial load.

Equivalent dynamic bearing load

As the CARB bearing can only accommodate radial loads

$$P = F_r$$

Equivalent static bearing load

As the CARB bearing can only accommodate radial loads

$$P_0 = F_r$$

Supplementary designations

The designation suffixes used to identify certain features of CARB bearings are explained in the following.

- C2** Radial internal clearance smaller than Normal
- C3** Radial internal clearance larger than Normal
- C4** Radial internal clearance larger than C3
- C5** Radial internal clearance larger than C4
- CS5** Sheet steel reinforced contact seal of hydrogenated acrylonitrile-butadiene rubber (HNBR) on one side of the bearing
- 2CS5** CS5 contact seal on both sides of the bearing. Free space in the bearing filled between 70 and 100 % with a high-temperature grease
- HA3** Case-hardened inner ring
- K** Tapered bore, taper 1:12
- K30** Tapered bore, taper 1:30
- M** Machined window-type brass cage, roller centred
- MB** Two-piece machined brass cage, inner ring centred
- TN9** Injection moulded window-type cage of glass fibre reinforced polyamide 4,6, roller centred
- V** Full complement of rollers (no cage)
- VE240** Bearing modified for greater axial displacement
- VG114** Surface hardened steel cage, roller centred

Free space on the sides of the bearing

To enable axial displacement of the shaft with respect to the housing it is necessary to provide free space on both sides of the bearing as indicated in **fig. 10**. The value for the width of this free space is based on

- the value C_a from the product tables
- the axial displacement of the bearing rings from the central position expected in operation
- the displacement of the rings caused by misalignment.

It can be obtained from

$$C_{\text{areq}} = C_a + 0,5 (s + s_{\text{mis}})$$

or

$$C_{\text{areq}} = C_a + 0,5 (s + k_1 B \alpha)$$

where

C_{areq} = width of space required on each side of the bearing, mm

C_a = minimum width of space required on each side of the bearing, mm
(→ product tables)

s = relative axial displacement of rings, e.g. thermal elongation of shaft, mm

s_{mis} = axial displacement of roller complement caused by misalignment, mm

k_1 = misalignment factor
(→ product tables)

B = bearing width, mm
(→ product tables)

α = misalignment, degrees

See also the section “Axial displacement” on **page 787**.

Normally the bearing rings are mounted so that they are not displaced with respect to each other. However, if considerable thermal changes in shaft length can be expected, the inner ring can be mounted offset with respect to the outer ring up to the permissible axial displacement s_1 or s_2 in the direction opposite to the expected thermal elongation (→ **fig. 11**). In this way, the permissible axial displacement can be appreciably extended, an advantage that is made use of for example in the bearing arrangements of drying cylinders in paper machines.

Mounting

When mounting a CARB bearing onto a shaft or in a housing, both bearing rings and the roller complement must be centred with respect to each other. For this reason SKF recommends mounting CARB bearings when the shaft or housing is in the horizontal position.

When mounting a CARB bearing onto a vertical shaft or into a vertical housing, the roller complement together with the inner or outer ring will move downwards until all clearance has been removed. Unless proper clearance is maintained

Fig. 10

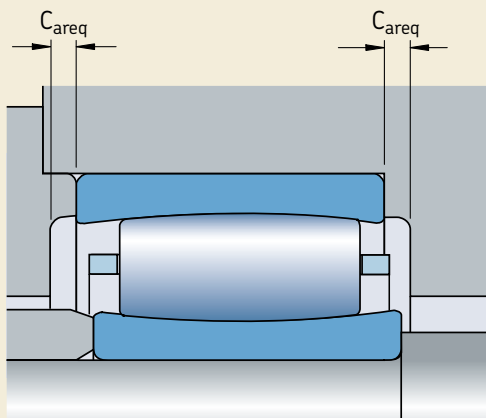
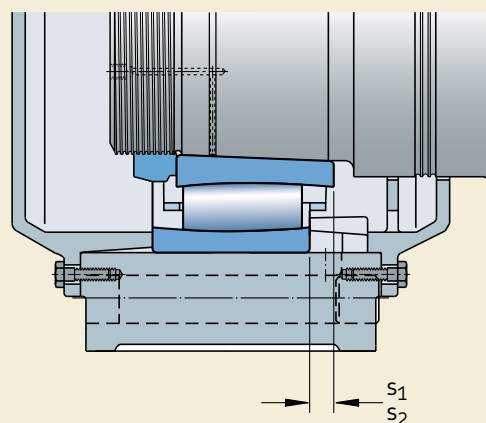

Fig. 11



during and after installation, the expansion or compression forces resulting from an interference fit on either the inner or outer ring will create a preload. This preload can cause indentations in the raceways and/or prevent the bearing from turning altogether. To prevent this preload condition from occurring during vertical mounting, a bearing-handling tool, which keeps the bearing components centred, should be used.

Mounting bearings with a tapered bore

Bearings with a tapered bore are always mounted with an interference fit. The reduction in radial internal clearance, or the axial displacement of the inner ring on its tapered seating is used as a measure of the degree of interference.

Suitable methods for mounting CARB bearings with a tapered bore are:

- Measuring the clearance reduction.
- Measuring the lock nut tightening angle.
- Measuring the axial drive-up.
- Measuring the inner ring expansion.

Small bearings with bore diameter up to 100 mm can be properly mounted by measuring the lock nut tightening angle.

For larger bearings the SKF Drive-up Method is recommended. This method is more accurate and takes less time than the procedure based on clearance reduction or the lock nut tightening angle. Measuring the inner ring expansion, i.e. applying the SensorMount® Method, enables large size bearings to be mounted simply, quick-

ly and accurately, since a sensor is integrated into the bearing inner ring.

Measuring the clearance reduction

This method, which uses feeler gauges for measuring the radial internal clearance before and after mounting bearings, is applicable for medium and large-sized bearings (→ fig. 12). Before measuring, rotate the outer ring a few times. Make sure that both bearing rings and the roller complement are centrally arranged with respect to each other.

For the first measurement, a blade should be selected which is slightly thinner than the minimum value for the clearance. During the measurement, the blade should be moved back and forth until it can be inserted to the middle of the roller. The procedure should be repeated using slightly thicker blades each time until a certain resistance is felt when moving between

- outer ring and uppermost roller (a) – before mounting
- inner or outer ring and lowest roller (b) depending on the cage – after mounting.

For larger bearings, especially those having a rather thin-walled outer ring, the measurements may be affected by the elastic deformation of the rings, caused by the weight of the bearing or the force to draw the feeler gauge blade through the gap between the raceway and an unloaded roller. To establish in such cases the

Fig. 12

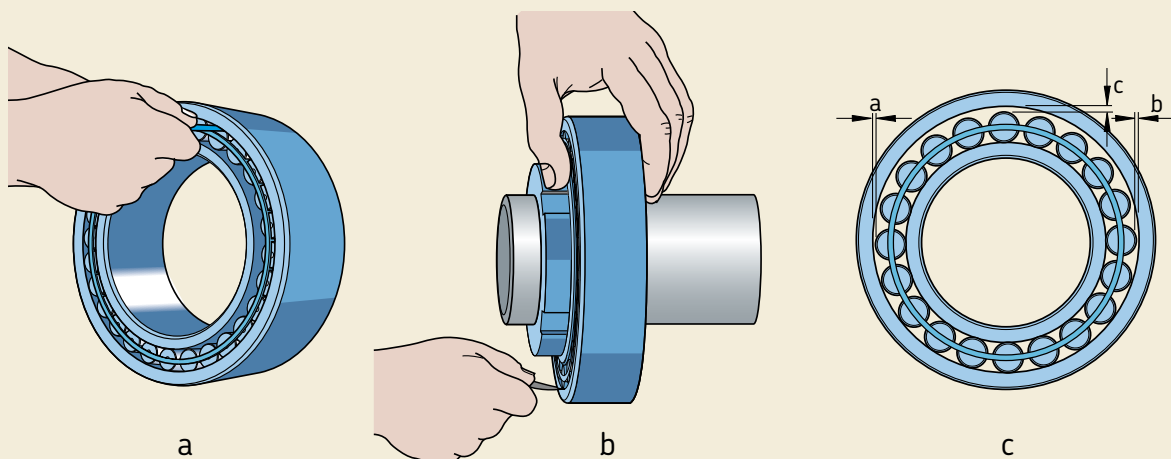

CARB toroidal roller bearings

“true” clearance before and after mounting, the following procedure should be followed (c):

- Measure the clearance “c” at the 12 o’clock position for a standing bearing or at the 6 o’clock position for a bearing hanging on a journal.
- Measure clearances “a” at the 9 o’clock position and “b” at the 3 o’clock position without the bearing being moved.
- Obtain the “true” radial internal clearance with relatively good accuracy from $0,5 (a + b + c)$.

Recommended values for reduction of radial internal clearance are provided in **table 3**.

Measuring the lock nut tightening angle

Mounting small to medium-size bearings on tapered seatings is easy when the tightening angle α of the lock nut (\rightarrow **fig. 13**) and the method that is described in the following is used. Recommended values for the tightening angle α are provided in **table 3**.

Before starting the final tightening procedure, the bearing should be pushed up on the tapered seating until the bore of the bearing or sleeve is in contact with the seating on the shaft around its whole circumference, i.e. the bearing inner ring cannot be rotated relatively to the shaft. By then turning the nut through the given angle α , the bearing will be pressed up the tapered seating. The residual clearance of the bearing should be checked, if possible.

Lock the nut by tightening the grub screw with the recommended tightening torque or by bending one of the locking washer tabs into one of the nut slots respectively.

Measuring the axial drive-up

Mounting bearings with a tapered bore can be done by measuring the axial drive-up of the inner ring on its seating. Recommended values for the required axial drive-up “s” for general applications are provided in **table 3** on **page 795**.

The most suitable method in this case is the SKF Drive-up Method. This mounting method provides a very reliable and easy way to determine the starting position for a bearing from which the axial displacement is to be meas-

Fig. 13

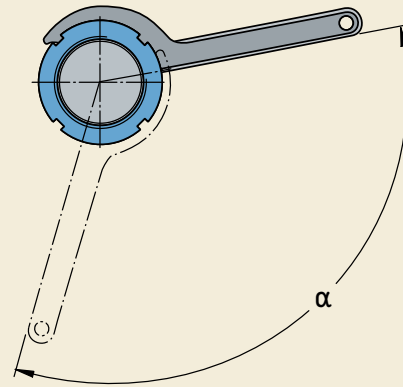

ured. For that, the following mounting tools (\rightarrow **fig. 14**) must be used

- an SKF hydraulic nut of the HMV .. E design (a)
- a hydraulic pump (b)
- a pressure gauge (c), appropriate to the mounting conditions
- a dial gauge (d).

Fig. 14

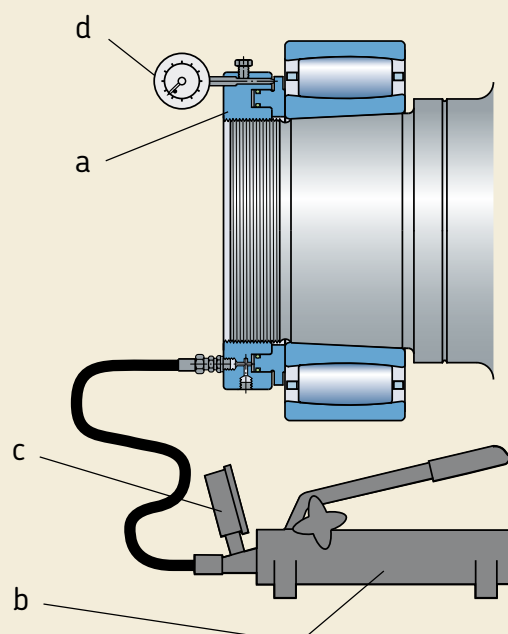
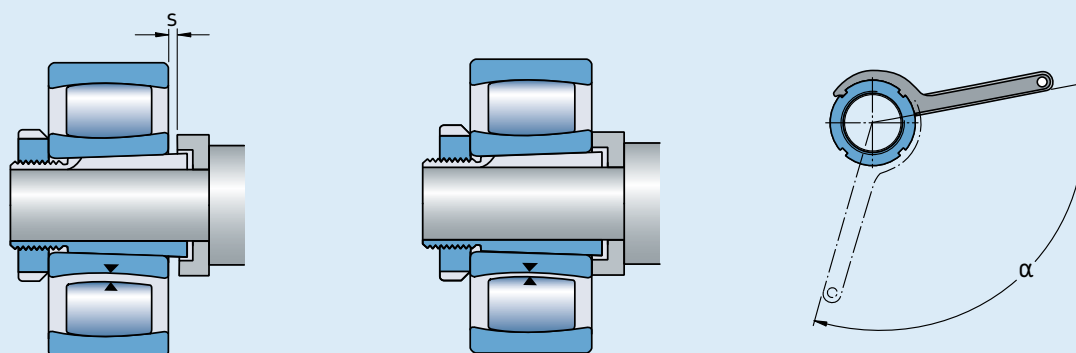

Table 3

Recommended values for reduction of radial internal clearance, axial drive-up and lock nut tightening angle



Bore diameter d		Reduction of radial internal clearance		Axial drive-up ¹⁾ s				Permissible residual ²⁾ radial clearance after mounting bearings with initial clearance			Lock nut tightening angle α
over	incl.	min	max	Taper 1:12		Taper 1:30		Normal	C3	C4	Taper 1:12
		mm		mm				mm			degrees
24	30	0,012	0,018	0,25	0,34	0,64	0,85	0,025	0,033	0,047	100
30	40	0,015	0,024	0,30	0,42	0,74	1,06	0,031	0,038	0,056	115
40	50	0,020	0,030	0,37	0,51	0,92	1,27	0,033	0,043	0,063	130
50	65	0,025	0,039	0,44	0,64	1,09	1,59	0,038	0,049	0,074	115
65	80	0,033	0,048	0,54	0,76	1,36	1,91	0,041	0,055	0,088	135
80	100	0,040	0,060	0,65	0,93	1,62	2,33	0,056	0,072	0,112	150
100	120	0,050	0,072	0,79	1,10	1,98	2,75	0,065	0,083	0,129	–
120	140	0,060	0,084	0,93	1,27	2,33	3,18	0,075	0,106	0,147	–
140	160	0,070	0,096	1,07	1,44	2,68	3,60	0,085	0,126	0,173	–
160	180	0,080	0,108	1,21	1,61	3,04	4,02	0,093	0,140	0,193	–
180	200	0,090	0,120	1,36	1,78	3,39	4,45	0,100	0,150	0,210	–
200	225	0,100	0,135	1,50	1,99	3,74	4,98	0,113	0,163	0,230	–
225	250	0,115	0,150	1,67	2,20	4,18	5,51	0,123	0,175	0,250	–
250	280	0,125	0,170	1,85	2,46	4,62	6,14	0,133	0,186	0,275	–
280	315	0,140	0,190	2,06	2,75	5,15	6,88	0,143	0,200	0,290	–
315	355	0,160	0,215	2,31	3,09	5,77	7,73	0,161	0,225	0,330	–
355	400	0,175	0,240	2,59	3,47	6,48	8,68	0,173	0,250	0,360	–
400	450	0,200	0,270	2,91	3,90	7,27	9,74	0,183	0,275	0,385	–
450	500	0,225	0,300	3,26	4,32	8,15	10,8	0,210	0,295	0,435	–
500	560	0,250	0,335	3,61	4,83	9,04	12,1	0,225	0,325	0,465	–
560	630	0,280	0,380	4,04	5,42	10,1	13,6	0,250	0,365	0,510	–
630	710	0,315	0,425	4,53	6,10	11,3	15,3	0,275	0,385	0,560	–
710	800	0,355	0,480	5,10	6,86	12,7	17,2	0,320	0,430	0,620	–
800	900	0,400	0,540	5,73	7,71	14,3	19,3	0,335	0,465	0,675	–
900	1 000	0,450	0,600	6,44	8,56	16,1	21,4	0,365	0,490	0,740	–
1 000	1 120	0,500	0,670	7,14	9,57	17,9	23,9	0,395	0,545	0,825	–
1 120	1 250	0,560	0,750	8	10,7	20	26,7	0,415	0,595	0,885	–

¹⁾ Valid only for solid steel shafts and general application. Not valid for the SKF Drive-up Method

²⁾ The residual clearance must be checked in cases where the initial radial internal clearance is in the lower half of the tolerance range, and where large temperature differentials between the bearing rings can arise in operation. The residual clearance must not be less than the values quoted above. When measuring, make sure that the rings and roller assembly are aligned and centred

CARB toroidal roller bearings

Applying the SKF Drive-up Method, the bearing is pushed up its seating to a defined starting position (→ **fig. 15**) using a given oil pressure (corresponding to a given drive-up force) in the hydraulic nut. In this way, part of the desired reduction in radial internal clearance is achieved. The oil pressure is monitored by the pressure gauge. The bearing is then driven up from the defined starting position through a given distance to its final position. The axial displacement " s_s " is accurately determined using the dial gauge mounted on the hydraulic nut.

SKF has determined values of the requisite oil pressure and the axial displacement for individual bearings. These values apply to bearing arrangements (→ **fig. 16**) with

- one sliding interface (**a** and **b**) or
- two sliding interfaces (**c**).

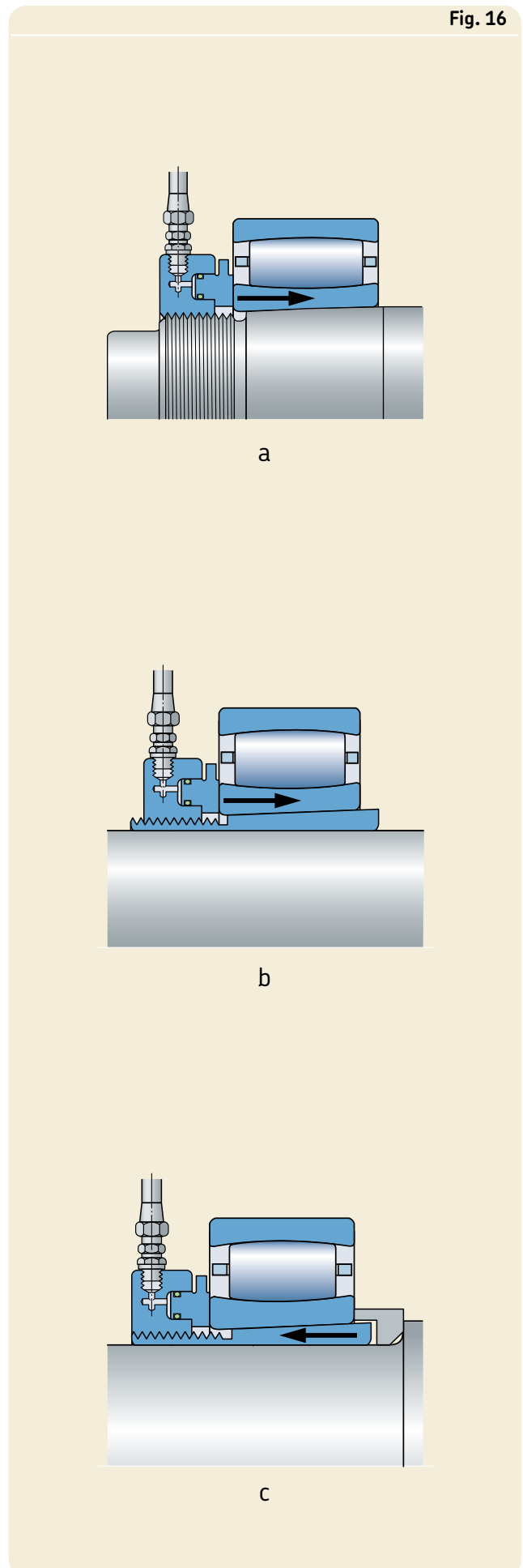
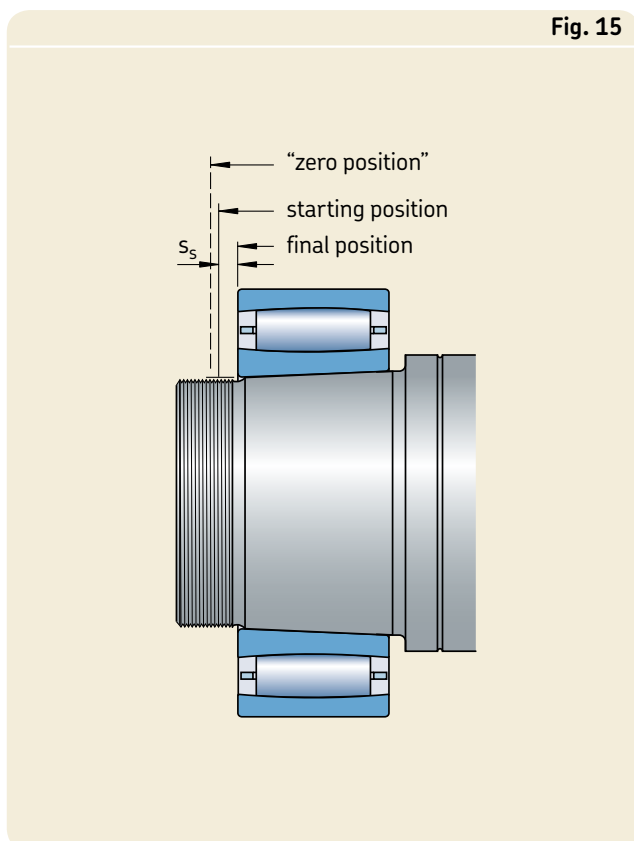

Measuring the inner ring expansion

Measuring inner ring expansion enables large size CARB bearings with a tapered bore to be mounted simply, quickly and accurately without measuring the radial internal clearance before and after mounting. The SensorMount® Method uses a sensor, integrated into the CARB bearing inner ring, and a dedicated hand-held indicator (→ fig. 17).

The bearing is driven up the tapered seating using common SKF mounting tools. The information from the sensor is processed by the indicator. Inner ring expansion is displayed as the relationship between the clearance reduction (mm) and the bearing bore diameter (m).

Aspects like bearing size, smoothness, shaft material or design – solid or hollow – do not need to be considered.

For detailed information about the Sensor-Mount Method, please contact the SKF application engineering service.

Additional mounting information

Additional information on mounting CARB bearings in general or with the aid of the SKF Drive-up Method can be found

- in the handbook “SKF Drive-up Method” on CD-ROM
- online at www.skf.com/mount.

Fig. 17

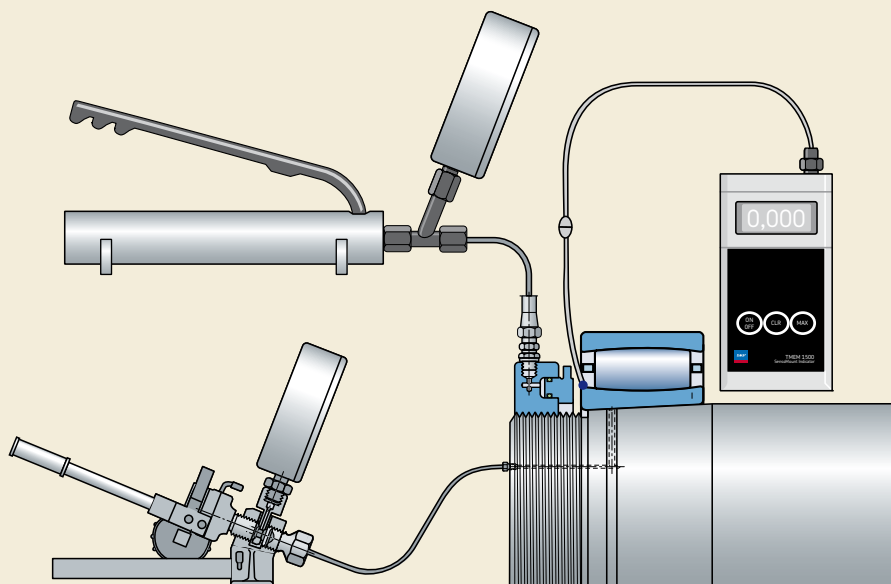

CARB toroidal roller bearings

d 25 – 55 mm

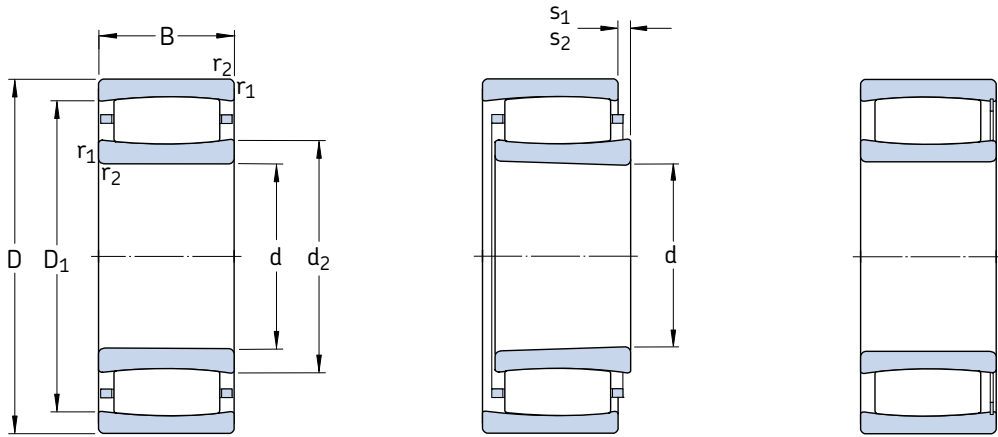

Cylindrical bore

Tapered bore

Full complement

Principal dimensions			Basic load ratings dynamic static		Fatigue load limit P _u	Speed ratings Refer- ence speed Limiting speed		Mass	Designations Bearing with cylindrical bore tapered bore	
d	D	B	C	C ₀				kg		
mm			kN		kN	r/min		kg	–	
25	52	18	44	40	4,55	13 000	18 000	0,17	* C 2205 TN9 ¹⁾	* C 2205 KTN9 ¹⁾
	52	18	50	48	5,5	–	7 000	0,18	* C 2205 V ¹⁾	* C 2205 KV ¹⁾
30	55	45	134	180	19,6	–	3 000	0,50	* C 6006 V	–
	62	20	69,5	62	7,2	11 000	15 000	0,27	* C 2206 TN9	* C 2206 KTN9
	62	20	76,5	71	8,3	–	6 000	0,29	* C 2206 V	* C 2206 KV
35	72	23	83	80	9,3	9 500	13 000	0,43	* C 2207 TN9	* C 2207 KTN9
	72	23	95	96,5	11,2	–	5 000	0,45	* C 2207 V	* C 2207 KV
40	62	22	76,5	100	11	–	4 300	0,25	* C 4908 V	* C 4908 K30V
	62	30	104	143	16	–	3 400	0,35	* C 5908 V ¹⁾	–
	62	40	122	180	19,3	–	2 800	0,47	* C 6908 V ¹⁾	–
	80	23	90	86,5	10,2	8 000	11 000	0,50	* C 2208 TN9	* C 2208 KTN9
	80	23	102	104	12	–	4 500	0,53	* C 2208 V	* C 2208 KV
45	68	22	81,5	112	12,9	–	3 800	0,30	* C 4909 V ¹⁾	* C 4909 K30V ¹⁾
	68	30	110	163	18,3	–	3 200	0,41	* C 5909 V ¹⁾	–
	68	40	132	200	22	–	2 600	0,55	* C 6909 V ¹⁾	–
	85	23	93	93	10,8	8 000	11 000	0,55	* C 2209 TN9	* C 2209 KTN9
	85	23	106	110	12,9	–	4 300	0,58	* C 2209 V	* C 2209 KV
50	72	22	86,5	125	13,7	–	3 600	0,29	* C 4910 V	* C 4910 K30V
	72	30	118	180	20,4	–	2 800	0,42	* C 5910 V ¹⁾	–
	72	40	140	224	24,5	–	2 200	0,54	* C 6910 V	–
80	80	30	116	140	16	5 000	7 500	0,55	* C 4010 TN9	* C 4010 K30TN9
	80	30	137	176	20	–	3 000	0,59	* C 4010 V	* C 4010 K30V
	90	23	98	100	11,8	7 000	9 500	0,59	* C 2210 TN9	* C 2210 KTN9
	90	23	114	122	14,3	–	3 800	0,62	* C 2210 V	* C 2210 KV
55	80	25	106	153	18	–	3 200	0,43	* C 4911 V ¹⁾	* C 4911 K30V ¹⁾
	80	34	143	224	25	–	2 600	0,60	* C 5911 V ¹⁾	–
	80	45	180	300	32,5	–	2 000	0,81	* C 6911 V ¹⁾	–
	100	25	116	114	13,4	6 700	9 000	0,79	* C 2211 TN9	* C 2211 KTN9
	100	25	132	134	16	–	3 400	0,81	* C 2211 V	* C 2211 KV

* SKF Explorer bearing

¹⁾ Please check availability of the bearing before incorporating it in a bearing arrangement design

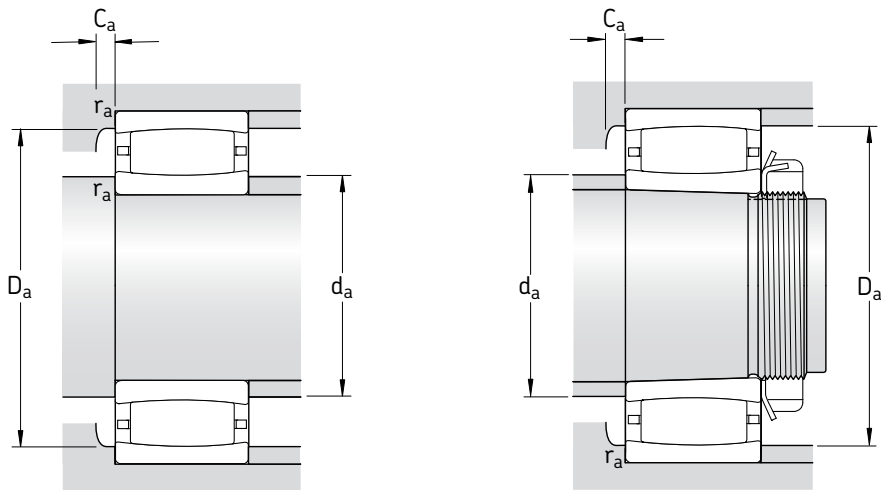

Dimensions						Abutment and fillet dimensions						Calculation factors	
d	d ₂	D ₁	r _{1,2} min	s ₁ ¹⁾	s ₂ ¹⁾	d _a min	d _a max	D _a min	D _a max	C _a ²⁾ min	r _a max	k ₁	k ₂
mm						mm						-	
25	32,1	43,3	1	5,8	-	30,6	32	42	46,4	0,3	1	0,09	0,126
	32,1	43,3	1	5,8	2,8	30,6	39	-	46,4	-	1	0,09	0,126
30	38,5	47,3	1	7,9	4,9	35,6	43	-	49,4	-	1	0,102	0,096
	37,4	53,1	1	4,5	-	35,6	37	51	56,4	0,3	1	0,101	0,111
	37,4	53,1	1	4,5	1,5	35,6	49	-	56,4	-	1	0,101	0,111
35	44,8	60,7	1,1	5,7	-	42	44	59	65	0,1	1	0,094	0,121
	44,8	60,7	1,1	5,7	2,7	42	57	-	65	-	1	0,094	0,121
40	46,1	55,3	0,6	4,7	1,7	43,2	52	-	58,8	-	0,6	0,099	0,114
	45,8	54,6	0,6	5	2	43,2	45	-	58,8	-	0,6	0,096	0,106
	46,6	53,8	0,6	9,4	6,4	43,2	46	-	58,8	-	0,6	0,113	0,088
	52,4	69,9	1,1	7,1	-	47	52	68	73	0,3	1	0,093	0,128
	52,4	69,9	1,1	7,1	4,1	47	66	-	73	-	1	0,093	0,128
45	51,6	60,5	0,6	4,7	1,7	48,2	51	-	64,8	-	0,6	0,114	0,1
	51,3	60,1	0,6	5	2	48,2	51	-	64,8	-	0,6	0,096	0,108
	52,1	59,3	0,6	9,4	6,4	48,2	52	-	64,8	-	0,6	0,113	0,09
	55,6	73,1	1,1	7,1	-	52	55	71	78	0,3	1	0,095	0,128
	55,6	73,1	1,1	7,1	4,1	52	69	-	78	-	1	0,095	0,128
50	56,9	66,1	0,6	4,7	1,7	53,2	62	-	68,8	-	0,6	0,103	0,114
	56,8	65,7	0,6	5	2	53,2	56	-	68,8	-	0,6	0,096	0,11
	57,5	65	0,6	9,4	6,4	53,2	61	-	68,8	-	0,6	0,093	0,113
	57,6	70,8	1	6	-	54,6	57	69	75,4	0,1	1	0,103	0,107
	57,6	70,8	1	6	3	54,6	67	-	75,4	-	1	0,103	0,107
55	61,9	79,4	1,1	7,1	-	57	61	77	83	0,8	1	0,097	0,128
	61,9	79,4	1,1	7,1	3,9	57	73	-	83	-	1	0,097	0,128
	62	72,1	1	5,5	2,5	59,6	62	-	80,4	-	1	0,107	0,105
55	62,8	72,4	1	6	3	59,6	62	-	80,4	-	1	0,097	0,109
	62,8	71,3	1	7,9	4,9	59,6	62	-	80,4	-	1	0,096	0,105
	65,8	86,7	1,5	8,6	-	64	65	84	91	0,3	1,5	0,094	0,133
	65,8	86,7	1,5	8,6	5,4	64	80	-	91	-	1,5	0,094	0,133

¹⁾ Permissible axial displacement from normal position of one bearing ring relative to the other (→ page 787)

²⁾ Minimum width of free space for bearings with cage in normal position (→ page 792)

CARB toroidal roller bearings
d 60 – 85 mm

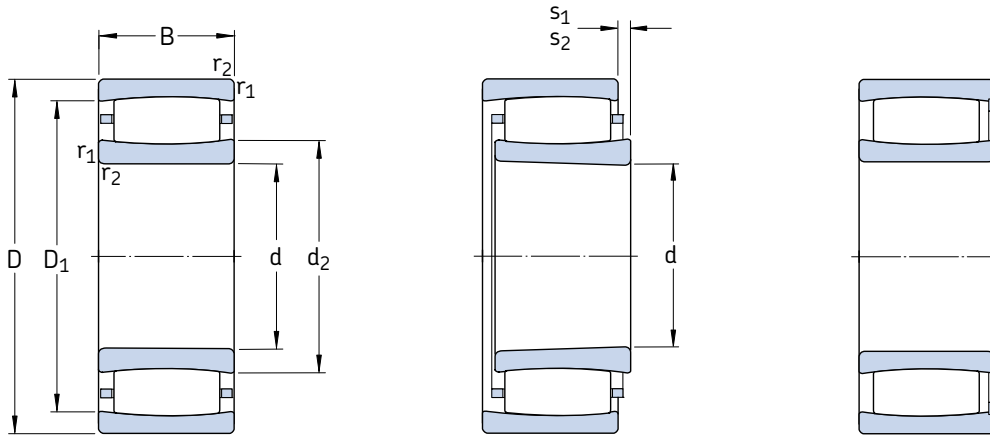

Cylindrical bore

Tapered bore

Full complement

Principal dimensions			Basic load ratings dynamic static		Fatigue load limit	Speed ratings		Mass	Designations	
d	D	B	C	C ₀	P _u	Refer- ence speed	Limiting speed		Bearing with cylindrical bore	tapered bore
mm			kN		kN	r/min		kg	–	
60	85	25	112	170	19,6	–	3 000	0,46	* C 4912 V ¹⁾	* C 4912 K30V ¹⁾
	85	34	150	240	26,5	–	2 400	0,64	* C 5912 V ¹⁾	–
	85	45	190	335	36	–	1 900	0,84	* C 6912 V	–
	110	28	143	156	18,3	5 600	7 500	1,10	* C 2212 TN9	* C 2212 KTN9
	110	28	166	190	22,4	–	2 800	1,15	* C 2212 V	* C 2212 KV
65	90	25	116	180	20,8	–	2 800	0,50	* C 4913 V ¹⁾	* C 4913 K30V ¹⁾
	90	34	156	260	30	–	2 200	0,70	* C 5913 V ¹⁾	–
	90	45	196	355	38	–	1 800	0,93	* C 6913 V ¹⁾	–
	100	35	196	275	32	–	2 400	1,00	* C 4013 V ¹⁾	* C 4013 K30V ¹⁾
	120	31	180	180	21,2	5 300	7 500	1,40	* C 2213 TN9	* C 2213 KTN9
	120	31	204	216	25,5	–	2 400	1,47	* C 2213 V	* C 2213 KV
70	100	30	163	240	28	–	2 600	0,78	* C 4914 V ¹⁾	* C 4914 K30V ¹⁾
	100	40	196	310	34,5	–	2 000	1,00	* C 5914 V ¹⁾	–
	100	54	265	455	49	–	1 700	1,40	* C 6914 V ¹⁾	–
	125	31	186	196	23,2	5 000	7 000	1,45	* C 2214 TN9	* C 2214 KTN9
	125	31	212	228	27	–	2 400	1,50	* C 2214 V	* C 2214 KV
	150	51	405	430	49	3 800	5 000	4,25	* C 2314	* C 2314 K
75	105	30	166	255	30	–	2 400	0,82	* C 4915 V ¹⁾	* C 4915 K30V ¹⁾
	105	40	204	325	37,5	–	1 900	1,10	* C 5915 V	–
	105	54	204	325	37,5	–	1 600	1,40	* C 6915 V/VE240	–
	115	40	236	345	40	–	2 000	1,50	* C 4015 V ¹⁾	* C 4015 K30V ¹⁾
	130	31	196	208	25,5	4 800	6 700	1,60	* C 2215	* C 2215 K
	130	31	220	240	29	–	2 200	1,65	* C 2215 V	* C 2215 KV
160	55	425	465	52	3 600	4 800	5,20	* C 2315	* C 2315 K	
80	110	30	173	275	31,5	–	2 200	0,87	* C 4916 V ¹⁾	* C 4916 K30V ¹⁾
	110	40	208	345	40	–	1 800	1,20	* C 5916 V ¹⁾	–
	140	33	220	250	28,5	4 500	6 000	2,00	* C 2216	* C 2216 K
	140	33	255	305	34,5	–	2 000	2,10	* C 2216 V	* C 2216 KV
	170	58	510	550	61	3 400	4 500	6,20	* C 2316	* C 2316 K
85	120	35	224	355	40,5	–	2 000	1,30	* C 4917 V ¹⁾	* C 4917 K30V ¹⁾
	120	46	275	465	52	–	1 700	1,70	* C 5917 V ¹⁾	–
	150	36	275	320	36,5	4 300	5 600	2,60	* C 2217	* C 2217 K
	150	36	315	390	44	–	1 800	2,80	* C 2217 V ¹⁾	* C 2217 KV ¹⁾
	180	60	540	600	65,5	3 200	4 300	7,30	* C 2317	* C 2317 K

* SKF Explorer bearing

¹⁾ Please check availability of the bearing before incorporating it in a bearing arrangement design

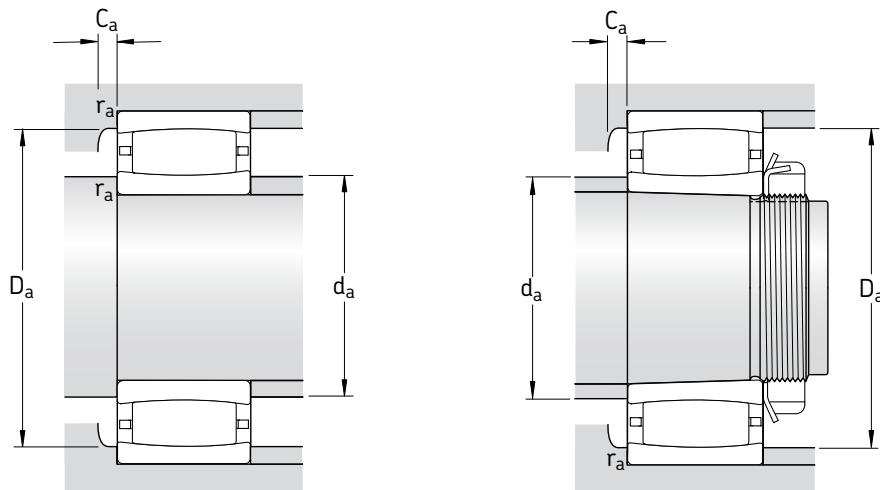

Dimensions						Abutment and fillet dimensions						Calculation factors	
d	d ₂	D ₁	r _{1,2} min	s ₁ ¹⁾	s ₂ ¹⁾	d _a min	d _a max	D _a min	D _a max	C _a ²⁾ min	r _a max	k ₁	k ₂
mm						mm						-	
60	68	78,2	1	5,5	2,3	64,6	68	-	80,4	-	1	0,107	0,108
	66,8	76,5	1	6	2,8	64,6	66	-	80,4	-	1	0,097	0,11
	68,7	77,5	1	7,9	4,7	64,6	72	-	80,4	-	1	0,108	0,096
	77,1	97,9	1,5	8,5	-	69	77	95	101	0,3	1,5	0,1	0,123
	77,1	97,9	1,5	8,5	5,3	69	91	-	101	-	1,5	0,1	0,123
65	72,1	82,2	1	5,5	2,3	69,6	72	-	85,4	-	1	0,107	0,109
	72,9	82,6	1	6	2,8	69,6	72	-	85,4	-	1	0,097	0,111
	72,9	81,4	1	7,9	4,7	69,6	72	-	85,4	-	1	0,096	0,107
	74,2	89,1	1,1	6	2,8	71	74	-	94	-	1	0,1	0,108
	79	106	1,5	9,6	-	74	79	102	111	0,2	1,5	0,097	0,127
	79	106	1,5	9,6	5,3	74	97	-	111	-	1,5	0,097	0,127
70	78	91	1	6	2,8	74,6	78	-	95,4	-	1	0,107	0,107
	78,7	90,3	1	9,4	6,2	74,6	78	-	95,4	-	1	0,114	0,095
	79,1	89,8	1	9	5,8	74,6	79	-	95,4	-	1	0,102	0,1
	83,7	111	1,5	9,6	-	79	83	107	116	0,4	1,5	0,098	0,127
	83,7	111	1,5	9,6	5,3	79	102	-	116	-	1,5	0,098	0,127
	91,4	130	2,1	9,1	-	82	105	120	138	2,2	2	0,11	0,099
75	83,1	96,1	1	6	2,8	79,6	83	-	100	-	1	0,107	0,108
	83,6	95,5	1	9,4	6,2	79,6	89	-	100	-	1	0,098	0,114
	83,6	95,5	1	9,2	9,2	79,6	88	-	100	-	1	0,073	0,154
	87,6	104	1,1	9,4	5,1	81	87	-	109	-	1	0,115	0,097
	88,5	115	1,5	9,6	-	84	98	110	121	1,2	1,5	0,099	0,127
	88,5	115	1,5	9,6	5,3	84	105	-	121	-	1,5	0,099	0,127
	98,5	135	2,1	13,1	-	87	110	130	148	2,2	2	0,103	0,107
	80	101	1	6	1,7	84,6	88	-	105	-	1	0,107	0,11
80	88,8	101	1	9,4	5,1	84,6	88	-	105	-	1	0,114	0,098
	98,1	125	2	9,1	-	91	105	120	129	1,2	2	0,104	0,121
	98,1	125	2	9,1	4,8	91	115	-	129	-	2	0,104	0,121
	102	145	2,1	10,1	-	92	115	135	158	2,4	2	0,107	0,101
	85	109	1,1	6	1,7	91	94	-	114	-	1	0,1	0,114
85	95	109	1,1	8,9	4,6	91	95	-	114	-	1	0,098	0,109
	104	133	2	7,1	-	96	110	125	139	1,3	2	0,114	0,105
	104	133	2	7,1	1,7	96	115	-	139	-	2	0,114	0,105
	110	153	3	12,1	-	99	125	145	166	2,4	2,5	0,105	0,105

¹⁾ Permissible axial displacement from normal position of one bearing ring relative to the other (→ page 787)

²⁾ Minimum width of free space for bearings with cage in normal position (→ page 792)

CARB toroidal roller bearings

d 90 – 130 mm

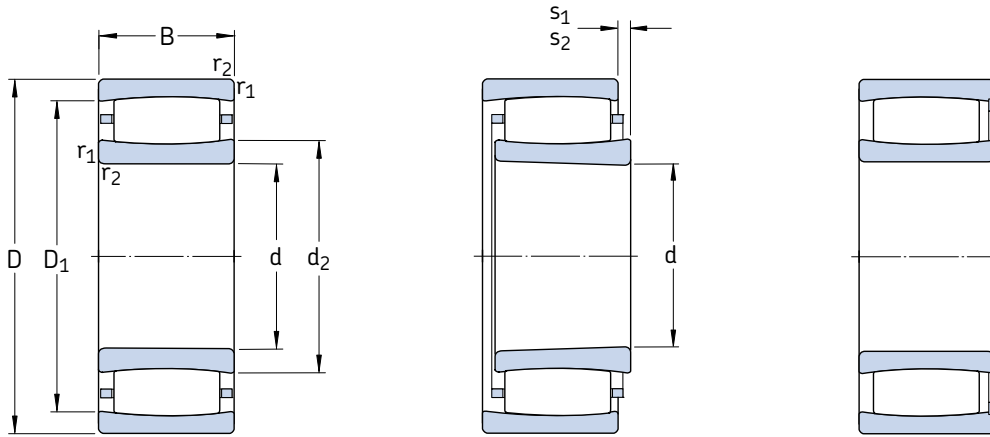

Cylindrical bore

Tapered bore

Full complement

Principal dimensions			Basic load ratings		Fatigue load limit P _u	Speed ratings		Mass	Designations	
d	D	B	dynamic	static		Refer- ence speed	Limiting speed		Bearing with cylindrical bore	tapered bore
mm			kN		kN	r/min		kg	–	
90	125	35	186	315	35,5	–	2 000	1,30	* C 4918 V ¹⁾	* C 4918 K30V ¹⁾
	125	46	224	400	44	–	1 600	1,75	* C 5918 V	–
	150	72	455	670	73,5	–	1 500	5,10	* BSC-2039 V	–
	160	40	325	380	42,5	3 800	5 300	3,30	* C 2218	* C 2218 K
	160	40	365	440	49	–	1 500	3,40	* C 2218 V ¹⁾	* C 2218 KV ¹⁾
	190	64	610	695	73,5	2 800	4 000	8,50	* C 2318	* C 2318 K
95	170	43	360	400	44	3 800	5 000	4,00	* C 2219 ¹⁾	* C 2219 K ¹⁾
	200	67	610	695	73,5	2 800	4 000	10,0	* C 2319	* C 2319 K
100	140	40	275	450	49	–	1 700	1,90	* C 4920 V ¹⁾	* C 4920 K30V ¹⁾
	140	54	375	640	68	–	1 400	2,70	* C 5920 V ¹⁾	–
	150	50	355	530	57	–	1 400	3,05	* C 4020 V	* C 4020 K30V
	150	67	510	865	90	–	1 100	4,30	* C 5020 V	–
	165	52	475	655	69,5	–	1 300	4,40	* C 3120 V	–
	165	65	475	655	69,5	–	1 300	5,25	* C 4120 V/VE240	* C 4120 K30V/VE240
	170	65	475	655	69,5	–	1 400	5,95	* BSC-2034 V	–
	180	46	415	465	47,5	3 600	4 800	4,85	* C 2220	* C 2220 K
	215	73	800	880	91,5	2 600	3 600	12,5	* C 2320	* C 2320 K
	110	170	45	355	480	51	3 200	4 500	3,50	* C 3022 ¹⁾
170		60	500	800	83	–	1 200	5,15	* C 4022 V	* C 4022 K30V
180		69	670	1 000	102	–	900	7,05	* C 4122 V	* C 4122 K30V
200		53	530	620	64	3 200	4 300	6,90	* C 2222	* C 2222 K
120	180	46	375	530	55	3 000	4 000	3,90	* C 3024 ¹⁾	* C 3024 K ¹⁾
	180	46	430	640	67	–	1 400	4,05	* C 3024 V	* C 3024 KV
	180	60	530	880	90	–	1 100	5,50	* C 4024 V	* C 4024 K30V
	200	80	780	1 120	114	–	750	10,5	* C 4124 V ¹⁾	* C 4124 K30V ¹⁾
	215	58	610	710	72	3 000	4 000	8,60	* C 2224 ¹⁾	* C 2224 K ¹⁾
	215	76	750	980	98	2 400	3 200	11,5	* C 3224	* C 3224 K
130	200	52	390	585	58,5	2 800	3 800	5,90	* C 3026 ¹⁾	* C 3026 K ¹⁾
	200	69	620	930	91,5	1 900	2 800	7,84	* C 4026	* C 4026 K30
	200	69	720	1 120	112	–	850	8,05	* C 4026 V	* C 4026 K30V
	210	80	750	1 100	108	–	670	10,5	* C 4126 V/VE240	* C 4126 K30V/VE240
	230	64	735	930	93	2 800	3 800	11,0	* C 2226	* C 2226 K

* SKF Explorer bearing

¹⁾ Please check availability of the bearing before incorporating it in a bearing arrangement design

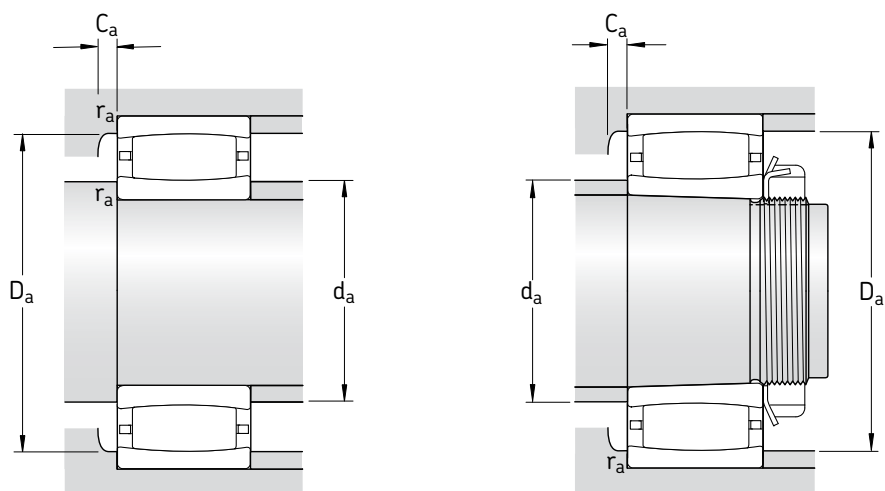

Dimensions						Abutment and fillet dimensions						Calculation factors	
d	d ₂	D ₁	r _{1,2} min	s ₁ ¹⁾	s ₂ ¹⁾	d _a min	d _a max	D _a min	D _a max	C _a ²⁾ min	r _a max	k ₁	k ₂
mm						mm						-	
90	102	113	1,1	11	6,7	96	100	-	119	-	1	0,125	0,098
	102	113	1,1	15,4	11,1	96	105	-	119	-	1	0,089	0,131
	109	131	2	19,7	19,7	101	115	-	139	-	2	0,087	0,123
	112	144	2	9,5	-	101	120	130	149	1,4	2	0,104	0,117
	112	144	2	9,5	5,4	101	125	-	149	-	2	0,104	0,117
119	166	3	9,6	-	104	135	155	176	2	2,5	0,108	0,101	
95	113	149	2,1	10,5	-	107	112	149	158	4,2	2	0,114	0,104
	120	166	3	12,6	-	109	135	155	186	2,1	2,5	0,103	0,106
100	113	130	1,1	9,4	5,1	106	110	-	134	-	1	0,115	0,103
	110	127	1,1	9	4,7	106	105	-	134	-	1	0,103	0,105
	113	135	1,5	14	9,7	109	120	-	141	-	1,5	0,098	0,118
	114	136	1,5	9,3	5	109	125	-	141	-	1,5	0,112	0,094
	119	150	2	10	4,7	111	130	-	154	-	2	0,1	0,112
120	148	2	17,7	17,7	111	130	-	154	-	2	0,09	0,125	
120	148	2	17,7	17,7	111	130	-	159	-	2	0,09	0,125	
118	157	2,1	10,1	-	112	130	150	168	0,9	2	0,108	0,11	
126	185	3	11,2	-	114	150	170	201	3,2	2,5	0,113	0,096	
110	128	156	2	9,5	-	119	127	157	161	4	2	0,107	0,11
	126	150	2	12	6,6	119	130	-	161	-	2	0,107	0,103
	132	163	2	11,4	4,6	120	145	-	170	-	2	0,111	0,097
	132	176	2,1	11,1	-	122	150	165	188	1,9	2	0,113	0,103
120	138	166	2	10,6	-	129	145	160	171	0,9	2	0,111	0,109
	138	166	2	10,6	3,8	129	150	-	171	-	2	0,111	0,109
	140	164	2	12	5,2	129	150	-	171	-	2	0,109	0,103
	140	176	2	18	11,2	131	140	-	189	-	2	0,103	0,103
	144	191	2,1	13	-	132	143	192	203	5,4	2	0,113	0,103
	149	190	2,1	17,1	-	132	160	180	203	2,4	2	0,103	0,108
130	154	180	2	16,5	-	139	152	182	191	4,4	2	0,123	0,1
	149	181	2	11,4	-	139	155	175	191	1,9	2	0,113	0,097
	149	181	2	11,4	4,6	139	165	-	191	-	2	0,113	0,097
	153	190	2	9,7	9,7	141	170	-	199	-	2	0,09	0,126
	152	199	3	9,6	-	144	170	185	216	1,1	2,5	0,113	0,10

¹⁾ Permissible axial displacement from normal position of one bearing ring relative to the other (→ page 787)

²⁾ Minimum width of free space for bearings with cage in normal position (→ page 792)

CARB toroidal roller bearings

d 140 – 190 mm

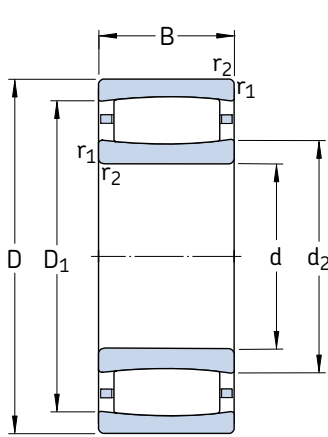

Cylindrical bore

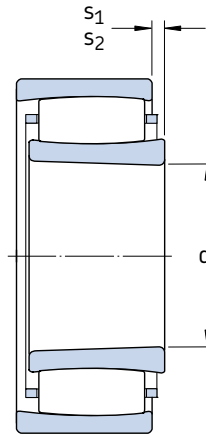

Tapered bore

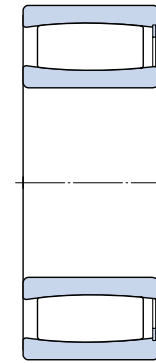

Full complement

Principal dimensions			Basic load ratings dynamic static		Fatigue load limit P_u	Speed ratings		Mass	Designations	
d	D	B	C	C_0		Refer- ence speed	Limiting speed		Bearing with cylindrical bore	tapered bore
mm			kN		kN	r/min		kg	–	
140	210	53	490	735	72	2 600	3 400	6,30	* C 3028 ¹⁾	* C 3028 K ¹⁾
	210	69	750	1 220	118	–	800	8,55	* C 4028 V	* C 4028 K30V
	225	85	1 000	1 600	153	–	630	14,2	* C 4128 V	* C 4128 K30V
	250	68	830	1 060	102	2 400	3 400	13,8	* C 2228	* C 2228 K
150	225	56	540	850	83	2 400	3 200	8,30	* C 3030 MB ¹⁾	* C 3030 KMB ¹⁾
	225	75	780	1 320	125	–	750	10,5	* C 4030 V	* C 4030 K30V
	250	80	880	1 290	122	2 000	2 800	15,0	* C 3130	* C 3130 K
	250	100	1 220	1 860	173	–	450	20,5	* C 4130 V ¹⁾	* C 4130 K30V ¹⁾
	270	73	980	1 220	116	2 400	3 200	17,5	* C 2230	* C 2230 K
160	240	60	600	980	93	2 200	3 000	9,60	* C 3032 ¹⁾	* C 3032 K ¹⁾
	240	80	795	1 160	110	1 600	2 400	12,3	* C 4032	* C 4032 K30
	240	80	915	1 460	140	–	600	12,6	* C 4032 V	* C 4032 K30V
	270	86	1 000	1 400	132	2 000	2 600	20,0	* C 3132 ¹⁾	* C 3132 K ¹⁾
	270	109	1 460	2 160	200	–	300	26,0	* C 4132 V ¹⁾	* C 4132 K30V ¹⁾
	290	104	1 370	1 830	170	1 700	2 400	28,5	* C 3232	* C 3232 K
170	260	67	750	1 160	108	2 000	2 800	12,5	* C 3034 ¹⁾	* C 3034 K ¹⁾
	260	90	1 140	1 860	170	–	500	17,5	* C 4034 V	* C 4034 K30V
	280	88	1 040	1 460	137	1 900	2 600	21,0	* C 3134 ¹⁾	* C 3134 K ¹⁾
	280	109	1 530	2 280	208	–	280	27,0	* C 4134 V ¹⁾	* C 4134 K30V ¹⁾
	310	86	1 270	1 630	150	2 000	2 600	28,0	* C 2234	* C 2234 K
180	280	74	880	1 340	125	1 900	2 600	16,5	* C 3036	* C 3036 K ²⁾
	280	100	1 320	2 120	193	–	430	23,0	* C 4036 V	* C 4036 K30V
	300	96	1 250	1 730	156	1 800	2 400	26,0	* C 3136	* C 3136 K ²⁾
	300	118	1 760	2 700	240	–	220	34,5	* C 4136 V ¹⁾	* C 4136 K30V ¹⁾
	320	112	1 530	2 200	196	1 500	2 000	37,0	* C 3236	* C 3236 K
190	290	75	930	1 460	132	1 800	2 400	17,5	* C 3038	* C 3038 K ²⁾
	290	100	1 370	2 320	204	–	380	24,5	* C 4038 V ¹⁾	* C 4038 K30V ¹⁾
	320	104	1 530	2 200	196	1 600	2 200	33,5	* C 3138 ¹⁾	* C 3138 K ¹⁾
	320	128	2 040	3 150	275	–	130	43,0	* C 4138 V ¹⁾	* C 4138 K30V ¹⁾
	340	92	1 370	1 730	156	1 800	2 400	34,0	* C 2238	* C 2238 K ²⁾

* SKF Explorer bearing

¹⁾ Please check availability of the bearing before incorporating it in a bearing arrangement design

²⁾ Also available in design K/HA3C4

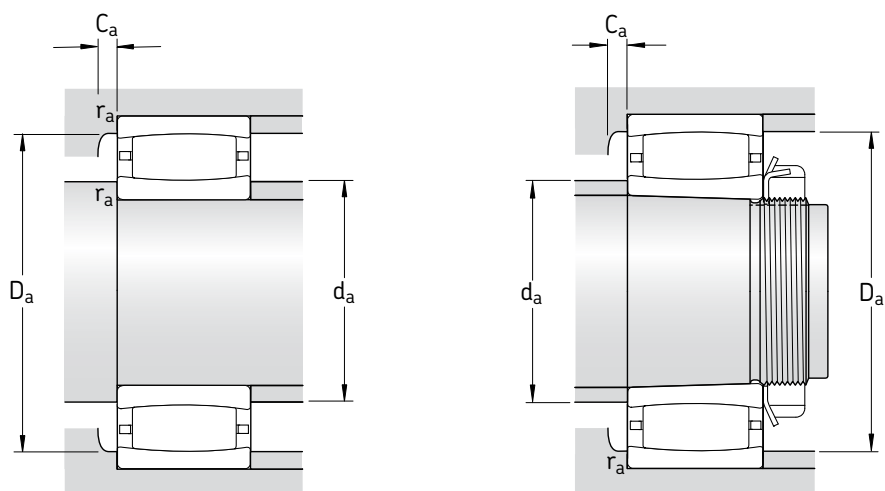

Dimensions						Abutment and fillet dimensions						Calculation factors	
d	d ₂	D ₁	r _{1,2} min	s ₁ ¹⁾	s ₂ ¹⁾	d _a min	d _a max	D _a min	D _a max	C _a ²⁾ min	r _a max	k ₁	k ₂
mm						mm						-	
140	163	194	2	11	-	149	161	195	201	4,7	2	0,102	0,116
	161	193	2	11,4	5,9	149	175	-	201	-	2	0,115	0,097
	167	203	2,1	12	5,2	151	185	-	214	-	2	0,111	0,097
	173	223	3	13,7	-	154	190	210	236	2,3	2,5	0,109	0,108
150	173	204	2,1	2,8	-	161	172	200	214	1,3	2	-	0,108
	173	204	2,1	17,4	10,6	161	185	-	214	-	2	0,107	0,106
	182	226	2,1	13,9	-	162	195	215	238	2,3	2	0,12	0,092
	179	222	2,1	20	10,1	162	175	-	228	-	2	0,103	0,103
	177	236	3	11,2	-	164	200	215	256	2,5	2,5	0,119	0,096
160	187	218	2,1	15	-	171	186	220	229	5,1	2	0,115	0,106
	181	217	2,1	18,1	-	171	190	210	229	2,2	2	0,109	0,103
	181	217	2,1	18,1	8,2	171	195	-	229	-	2	0,109	0,103
	191	240	2,1	19	-	172	190	242	258	7,5	2	0,099	0,111
	190	241	2,1	21	11,1	172	190	-	258	-	2	0,101	0,105
	194	256	3	19,3	-	174	215	245	276	2,6	2,5	0,112	0,096
170	200	237	2,1	12,5	-	181	200	238	249	5,8	2	0,105	0,112
	195	235	2,1	17,1	7,2	181	215	-	249	-	2	0,108	0,103
	200	249	2,1	21	-	182	200	250	268	7,6	2	0,101	0,109
	200	251	2,1	21	11,1	182	200	-	268	-	2	0,101	0,106
	209	274	4	16,4	-	187	230	255	293	3	3	0,114	0,1
180	209	251	2,1	15,1	-	191	220	240	269	2	2	0,112	0,105
	203	247	2,1	20,1	10,2	191	225	-	269	-	2	0,107	0,103
	210	266	3	23,2	-	194	230	255	286	2,2	2,5	0,102	0,111
	211	265	3	20	10,1	194	210	-	286	-	2,5	0,095	0,11
	228	289	4	27,3	-	197	245	275	303	3,2	3	0,107	0,104
	190	225	266	2,1	16,1	-	201	235	255	279	1,9	2	0,113
220		263	2,1	20	10,1	201	220	-	279	-	2	0,103	0,106
228		289	3	19	-	204	227	290	306	9,1	2,5	0,096	0,113
222		284	3	20	10,1	204	220	-	306	-	2,5	0,094	0,111
224		296	4	22,5	-	207	250	275	323	1,6	3	0,108	0,108

¹⁾ Permissible axial displacement from normal position of one bearing ring relative to the other (→ page 787)

²⁾ Minimum width of free space for bearings with cage in normal position (→ page 792)

CARB toroidal roller bearings

d 200 – 380 mm

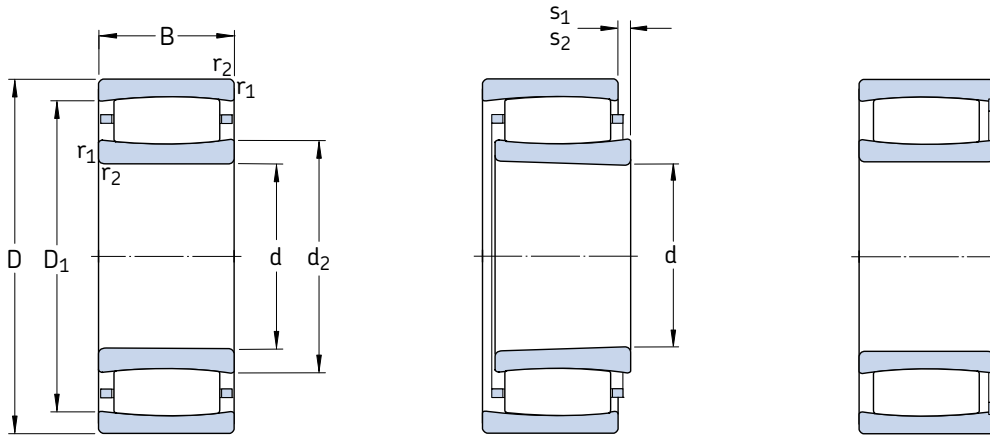

Cylindrical bore

Tapered bore

Full complement

Principal dimensions			Basic load ratings dynamic static		Fatigue load limit P _u	Speed ratings		Mass	Designations	
d	D	B	C	C ₀		Refer- ence speed	Limiting speed		Bearing with cylindrical bore	tapered bore
mm			kN		kN	r/min		kg	–	
200	310	82	1 120	1 730	153	1 700	2 400	22,0	* C 3040	* C 3040 K ²⁾
	310	109	1 630	2 650	232	–	260	30,5	* C 4040 V	* C 4040 K30V
	340	112	1 600	2 320	204	1 500	2 000	40,0	* C 3140	* C 3140 K ²⁾
	340	140	2 360	3 650	315	–	80	54,0	* C 4140 V ¹⁾	* C 4140 K30V ¹⁾
220	340	90	1 320	2 040	176	1 600	2 200	29,0	* C 3044	* C 3044 K ²⁾
	340	118	1 930	3 250	275	–	200	40,0	* C 4044 V ¹⁾	* C 4044 K30V ¹⁾
	370	120	1 900	2 900	245	1 400	1 900	51,0	* C 3144	* C 3144 K ²⁾
	400	108	2 000	2 500	216	1 500	2 000	56,5	* C 2244	* C 2244 K ²⁾
240	360	92	1 340	2 160	180	1 400	2 000	31,5	* C 3048	* C 3048 K ²⁾
	400	128	2 320	3 450	285	1 300	1 700	63,0	* C 3148	* C 3148 K ²⁾
260	400	104	1 760	2 850	232	1 300	1 800	46,0	* C 3052	* C 3052 K ²⁾
	440	144	2 650	4 050	325	1 100	1 500	87,0	* C 3152	* C 3152 K ²⁾
280	420	106	1 860	3 100	250	1 200	1 600	50,0	* C 3056	* C 3056 K ²⁾
	460	146	2 850	4 500	355	1 100	1 400	93,0	* C 3156	* C 3156 K ²⁾
300	460	118	2 160	3 750	290	1 100	1 500	71,0	* C 3060 M	* C 3060 KM
	460	160	2 900	4 900	380	850	1 200	95,0	* C 4060 M	* C 4060 K30M
	500	160	3 250	5 200	400	1 000	1 300	120	* C 3160	* C 3160 K ²⁾
320	480	121	2 280	4 000	310	1 000	1 400	76,5	* C 3064 M	* C 3064 KM
	540	176	4 150	6 300	480	950	1 300	160	* C 3164 M	* C 3164 KM
340	520	133	2 900	5 000	375	950	1 300	100	* C 3068 M	* C 3068 KM
	580	190	4 900	7 500	560	850	1 200	205	* C 3168 M	* C 3168 KM ²⁾
360	480	90	1 760	3 250	250	1 000	1 400	44,0	* C 3972 M	* C 3972 KM
	540	134	2 900	5 000	375	900	1 200	105	* C 3072 M	* C 3072 KM ²⁾
	600	192	5 000	8 000	585	800	1 100	215	* C 3172 M	* C 3172 KM ²⁾
380	520	106	2 120	4 000	300	950	1 300	65,5	* C 3976 MB ¹⁾	* C 3976 KMB ¹⁾
	560	135	3 000	5 200	390	900	1 200	110	* C 3076 M	* C 3076 KM
	620	194	4 550	7 500	540	750	1 000	230	* C 3176 MB ¹⁾	* C 3176 KMB ¹⁾

* SKF Explorer bearing

¹⁾ Please check availability of the bearing before incorporating it in a bearing arrangement design

²⁾ Also available in design K/HA3C4 or KM/HA3C4 respectively

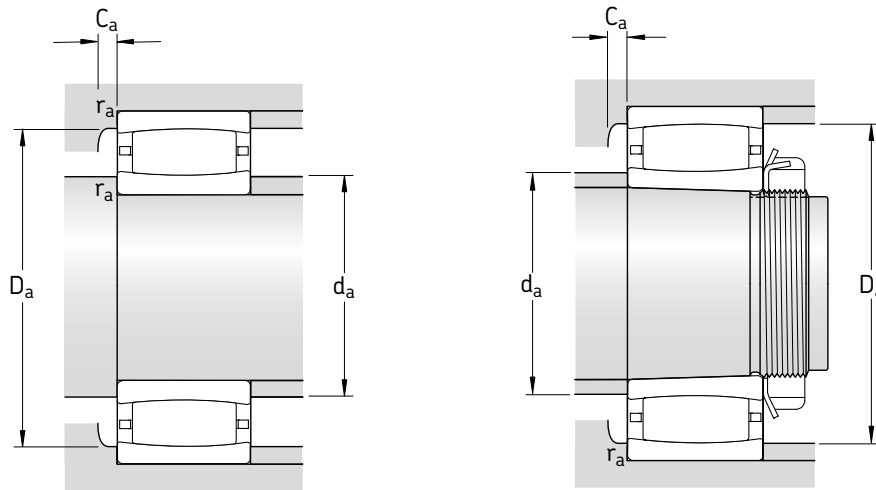

Dimensions						Abutment and fillet dimensions						Calculation factors	
d	d ₂	D ₁	r _{1,2} min	s ₁ ¹⁾	s ₂ ¹⁾	d _a min	d _a max	D _a min	D _a max	C _a ²⁾ min	r _a max	k ₁	k ₂
mm						mm						-	
200	235	285	2,1	15,2	-	211	250	275	299	2,9	2	0,123	0,095
	229	280	2,1	21	11,1	211	225	-	299	-	2	0,11	0,101
	245	305	3	27,3	-	214	260	307	326	-	2,5	0,108	0,104
	237	302	3	22	12,1	214	235	-	326	-	2,5	0,092	0,112
220	257	310	3	17,2	-	233	270	295	327	3,1	2,5	0,114	0,104
	251	306	3	20	10,1	233	250	-	327	-	2,5	0,095	0,113
	268	333	4	22,3	-	237	290	315	353	3,5	3	0,114	0,097
	259	350	4	20,5	-	237	295	320	383	1,7	3	0,113	0,101
240	276	329	3	19,2	-	253	290	315	347	1,3	2,5	0,113	0,106
	281	357	4	20,4	-	257	305	335	383	3,7	3	0,116	0,095
260	305	367	4	19,3	-	275	325	350	385	3,4	3	0,122	0,096
	314	394	4	26,4	-	277	340	375	423	4,1	3	0,115	0,096
280	328	389	4	21,3	-	295	350	375	405	1,8	3	0,121	0,098
	336	416	5	28,4	-	300	360	395	440	4,1	4	0,115	0,097
300	352	417	4	20	-	315	375	405	445	1,7	3	0,123	0,095
	338	409	4	30,4	-	315	360	400	445	2,8	3	0,105	0,106
	362	448	5	30,5	-	320	390	425	480	4,9	4	0,106	0,106
320	376	440	4	23,3	-	335	395	430	465	1,8	3	0,121	0,098
	372	476	5	26,7	-	340	410	455	520	3,9	4	0,114	0,096
340	402	482	5	25,4	-	358	430	465	502	1,9	4	0,12	0,099
	405	517	5	25,9	-	360	445	490	560	4,2	4	0,118	0,093
360	394	450	3	17,2	-	373	405	440	467	1,6	2,5	0,127	0,104
	417	497	5	26,4	-	378	445	480	522	2	4	0,12	0,099
	423	537	5	27,9	-	380	460	510	522	3,9	4	0,117	0,094
380	429	489	4	10	-	395	425	490	505	9,7	3	-	0,128
	431	511	5	27	-	398	460	495	542	2	4	0,12	0,1
	450	550	5	19	-	400	445	555	600	16,4	4	-	0,106

¹⁾ Permissible axial displacement from normal position of one bearing ring relative to the other (→ page 787)

²⁾ Minimum width of free space for bearings with cage in normal position (→ page 792)

CARB toroidal roller bearings
d 400 – 600 mm

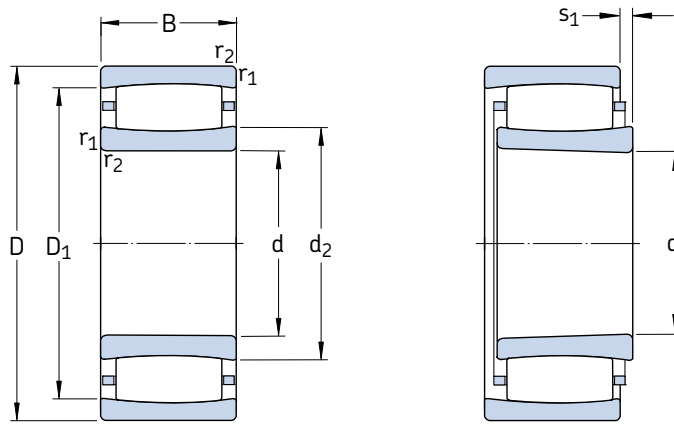

Cylindrical bore

Tapered bore

Principal dimensions			Basic load ratings dynamic static		Fatigue load limit	Speed ratings		Mass	Designations	
d	D	B	C	C ₀	P _u	Refer- ence speed	Limiting speed	kg	Bearing with cylindrical bore	tapered bore
mm			kN		kN	r/min			–	
400	540	106	2 160	4 150	305	900	1 300	69,0	* C 3980 MB ¹⁾	* C 3980 KMB ¹⁾
	600	148	3 650	6 200	450	800	1 100	140	* C 3080 M	* C 3080 KM
	650	200	5 000	8 650	610	700	950	275	* C 3180 MB	* C 3180 KMB
420	560	106	2 160	4 250	310	850	1 200	71,0	* C 3984 M	* C 3984 KM
	620	150	3 800	6 400	465	800	1 100	150	* C 3084 M	* C 3084 KM
	700	224	6 000	10 400	710	670	900	340	* C 3184 M	* C 3184 KM ²⁾
440	600	118	2 750	5 300	375	800	1 100	98,0	* C 3988 MB ¹⁾	* C 3988 KMB ¹⁾
	650	157	3 750	6 400	465	750	1 000	185	* C 3088 MB	* C 3088 KMB
	720	226	5 700	9 300	655	670	900	360	* C 3188 MB ¹⁾	* C 3188 KMB ¹⁾
460	620	118	2 700	5 300	375	800	1 100	100	* C 3992 MB ¹⁾	* C 3992 KMB ¹⁾
	680	163	4 000	7 500	510	700	950	200	* C 3092 M	* C 3092 KM ²⁾
	760	240	6 800	12 000	800	600	800	430	* C 3192 M	* C 3192 KM
	760	300	8 300	14 300	950	480	630	535	* C 4192 M	* C 4192 K30M
480	650	128	3 100	6 100	430	750	1 000	120	* C 3996 M	* C 3996 KM
	700	165	4 050	7 800	530	670	900	210	* C 3096 M	* C 3096 KM
	790	248	6 950	12 500	830	560	750	490	* C 3196 MB ¹⁾	* C 3196 KMB ¹⁾
500	670	128	3 150	6 300	440	700	950	125	* C 39/500 M	* C 39/500 KM
	720	167	4 250	8 300	560	630	900	225	* C 30/500 M	* C 30/500 KM ²⁾
	830	264	7 500	12 700	850	530	750	550	* C 31/500 M	* C 31/500 KM ²⁾
	830	325	9 800	17 600	1 140	400	560	720	* C 41/500 MB	* C 41/500 K30MB
530	710	136	3 550	7 100	490	670	900	150	* C 39/530 M	* C 39/530 KM
	780	185	5 100	9 500	640	600	800	295	* C 30/530 M	* C 30/530 KM ²⁾
	870	272	8 800	15 600	1 000	500	670	630	* C 31/530 M	* C 31/530 KM ²⁾
560	750	140	3 600	7 350	490	600	850	170	* C 39/560 M	* C 39/560 KM
	820	195	5 600	11 000	720	530	750	345	* C 30/560 M	* C 30/560 KM ²⁾
	920	280	9 500	17 000	1 100	480	670	750	* C 31/560 MB ¹⁾	* C 31/560 KMB ¹⁾
600	800	150	4 000	8 800	570	560	750	210	* C 39/600 M	* C 39/600 KM
	870	200	6 300	12 200	780	500	700	390	* C 30/600 M	* C 30/600 KM ²⁾
	980	300	10 200	18 000	1 120	430	600	870	* C 31/600 MB ¹⁾	* C 31/600 KMB ¹⁾

* SKF Explorer bearing

¹⁾ Please check availability of the bearing before incorporating it in a bearing arrangement design

²⁾ Also available in design KM/HA3C4

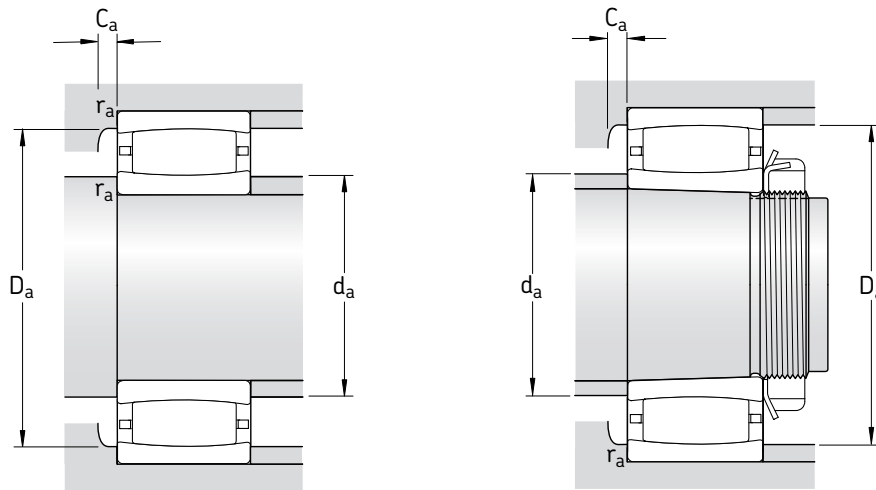

Dimensions					Abutment and fillet dimensions						Calculation factors	
d	d ₂ ~	D ₁ ~	r _{1,2} min	s ₁ ¹⁾ ~	d _a min	d _a max	D _a min	D _a max	C _a ²⁾ min	r _a max	k ₁	k ₂
mm					mm						-	
400	440	500	4	10	415	435	505	525	9,7	3	-	0,128
	458	553	5	30,6	418	480	525	582	2,1	4	0,121	0,099
	485	589	6	10,1	426	480	565	624	4,4	5	-	0,109
420	462	522	4	21,3	435	480	515	545	1,8	3	0,132	0,098
	475	570	5	32,6	438	510	550	602	2,2	4	0,12	0,1
	508	618	6	34,8	446	540	595	674	3,8	5	0,113	0,098
440	495	564	4	11	455	490	565	585	10,5	3	-	0,119
	491	587	6	19,7	463	490	565	627	1,7	5	-	0,105
	514	633	6	22	466	510	635	694	19,1	5	-	0,102
460	508	577	4	11	475	505	580	605	10,4	3	-	0,12
	539	624	6	33,5	486	565	605	654	2,3	5	0,114	0,108
	559	679	7,5	51	492	570	655	728	4,2	6	0,108	0,105
	540	670	7,5	46,2	492	570	655	728	5,6	6	0,111	0,097
480	529	604	5	20,4	498	550	590	632	2	4	0,133	0,095
	555	640	6	35,5	503	580	625	677	2,3	5	0,113	0,11
	583	700	7,5	24	512	580	705	758	20,6	6	-	0,104
500	556	631	5	20,4	518	580	615	652	2	4	0,135	0,095
	572	656	6	37,5	523	600	640	697	2,3	5	0,113	0,111
	605	738	7,5	75,3	532	655	705	798	-	6	0,099	0,116
	598	740	7,5	16,3	532	595	705	798	5,9	6	-	0,093
530	578	657	5	28,4	548	600	640	692	2,2	4	0,129	0,101
	601	704	6	35,7	553	635	685	757	2,5	5	0,12	0,101
	635	781	7,5	44,4	562	680	745	838	4,8	6	0,115	0,097
560	622	701	5	32,4	578	645	685	732	2,3	4	0,128	0,104
	660	761	6	45,7	583	695	740	793	2,7	5	0,116	0,106
	664	808	7,5	28	592	660	810	888	23,8	6	-	0,111
600	666	744	5	32,4	618	685	725	782	2,4	4	0,131	0,1
	692	805	6	35,9	623	725	775	847	2,7	5	0,125	0,098
	710	870	7,5	30	632	705	875	948	25,4	6	-	0,105

¹⁾ Permissible axial displacement from normal position of one bearing ring relative to the other (→ page 787)

²⁾ Minimum width of free space for bearings with cage in normal position (→ page 792)

CARB toroidal roller bearings

d 630 – 1 250 mm

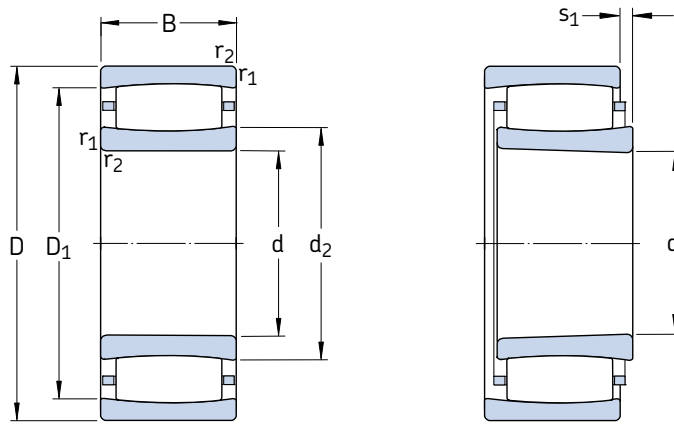

Cylindrical bore

Tapered bore

Principal dimensions			Basic load ratings		Fatigue load limit P_u	Speed ratings		Mass	Designations	
d	D	B	C	C_0		Refer- ence speed	Limiting speed		Bearing with cylindrical bore	tapered bore
mm			kN		kN	r/min		kg	–	
630	850	165	4 650	10 000	640	530	700	270	* C 39/630 M	* C 39/630 KM
	920	212	6 800	12 900	830	480	670	465	* C 30/630 M	* C 30/630 KM ²⁾
	1 030	315	12 200	22 000	1 370	400	560	1 040	* C 31/630 MB ¹⁾	* C 31/630 KMB ¹⁾
670	900	170	4 900	11 200	695	480	630	310	* C 39/670 M	* C 39/670 KM
	980	230	8 150	16 300	1 000	430	600	580	* C 30/670 M	* C 30/670 KM ²⁾
	1 090	336	12 000	22 000	1 320	380	530	1 230	* C 31/670 MB ¹⁾	* C 31/670 KMB ¹⁾
710	950	180	6 000	12 500	780	450	630	355	* C 39/710 M	* C 39/710 KM
	1 030	236	8 800	17 300	1 060	400	560	645	* C 30/710 M	* C 30/710 KM
	1 030	315	10 600	21 600	1 290	320	430	860	* C 40/710 M	* C 40/710 K30M
	1 150	345	12 700	24 000	1 430	360	480	1 410	* C 31/710 MB ¹⁾	* C 31/710 KMB ¹⁾
750	1 000	185	6 100	13 400	815	430	560	405	* C 39/750 M	* C 39/750 KM
	1 090	250	9 000	18 000	1 100	380	530	770	* C 30/750 MB ¹⁾	* C 30/750 KMB ¹⁾
	1 220	365	16 000	30 500	1 800	320	450	1 700	* C 31/750 MB ¹⁾	* C 31/750 KMB ¹⁾
800	1 060	195	6 400	14 600	865	380	530	470	* C 39/800 M	* C 39/800 KM
	1 150	258	9 150	18 600	1 120	360	480	860	* C 30/800 MB ¹⁾	* C 30/800 KMB ¹⁾
	1 280	375	15 600	30 500	1 760	300	400	1 870	* C 31/800 MB ¹⁾	* C 31/800 KMB ¹⁾
850	1 120	200	7 350	16 300	965	360	480	530	* C 39/850 M	* C 39/850 KM
	1 220	272	11 200	24 000	1 370	320	430	1 050	* C 30/850 MB ¹⁾	* C 30/850 KMB ¹⁾
	1 360	400	16 000	32 000	1 830	280	380	2 260	* C 31/850 MB ¹⁾	* C 31/850 KMB ¹⁾
900	1 180	206	8 150	18 000	1 060	340	450	580	* C 39/900 MB ¹⁾	* C 39/900 KMB ¹⁾
	1 280	280	12 700	26 500	1 530	300	400	1 150	* C 30/900 M	* C 30/900 KM
950	1 250	224	9 300	22 000	1 250	300	430	745	* C 39/950 M	* C 39/950 KM
	1 360	300	12 900	27 500	1 560	280	380	1 410	* C 30/950 MB ¹⁾	* C 30/950 KMB ¹⁾
1 000	1 420	308	13 400	29 000	1 630	260	340	1 570	* C 30/1000 MB ¹⁾	* C 30/1000 KMB ¹⁾
	1 580	462	22 800	45 500	2 500	220	300	3 470	* C 31/1000 MB ¹⁾	* C 31/1000 KMB ¹⁾
1 060	1 400	250	12 500	29 000	1 600	260	340	1 040	* C 39/1060 MB ¹⁾	* C 39/1060 KMB ¹⁾
1 180	1 540	272	12 900	31 500	1 660	220	300	1 340	* C 39/1180 M	* C 39/1180 KM
1 250	1 750	375	20 400	45 000	2 320	180	240	2 740	* C 30/1250 MB ¹⁾	* C 30/1250 KMB ¹⁾

* SKF Explorer bearing

¹⁾ Please check availability of the bearing before incorporating it in a bearing arrangement design

²⁾ Also available in design KM/HA3C4

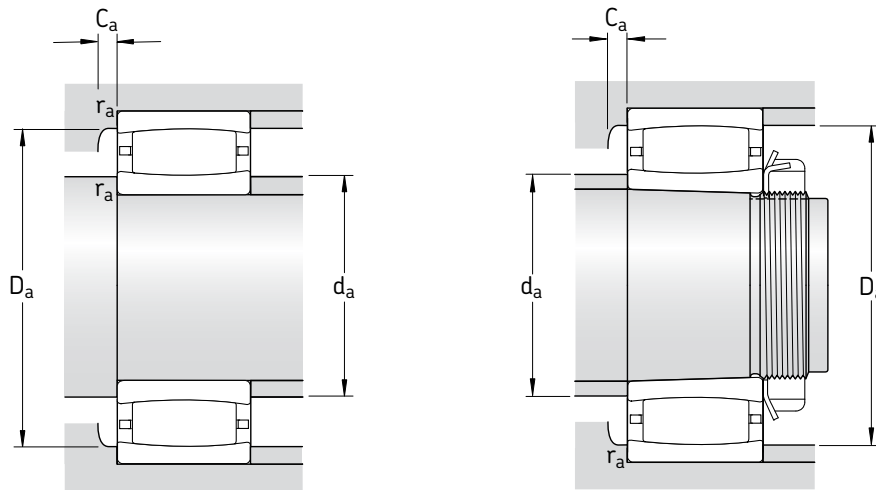

Dimensions					Abutment and fillet dimensions						Calculation factors	
d	d ₂ ~	D ₁ ~	r _{1,2} min	s ₁ ¹⁾ ~	d _a min	d _a max	D _a min	D _a max	C _a ²⁾ min	r _a max	k ₁	k ₂
mm					mm						-	
630	700	784	6	35,5	653	720	770	827	2,4	5	0,121	0,11
	717	840	7,5	48,1	658	755	810	892	2,9	6	0,118	0,104
	749	919	7,5	31	662	745	920	998	26,8	6	-	0,109
670	764	848	6	40,5	693	765	830	877	2,5	5	0,121	0,113
	775	904	7,5	41,1	698	820	875	952	2,9	6	0,121	0,101
	797	963	7,5	33	702	795	965	1 058	28	6	-	0,104
710	773	877	6	30,7	733	795	850	927	2,7	5	0,131	0,098
	807	945	7,5	47,3	738	850	910	1 002	3,2	6	0,119	0,104
	803	935	7,5	51,2	738	840	915	1 002	4,4	6	0,113	0,101
	848	1 012	9,5	34	750	845	1 015	1 100	28,6	8	-	0,102
750	830	933	6	35,7	773	855	910	977	2,7	5	0,131	0,101
	858	993	7,5	25	778	855	995	1 062	21,8	6	-	0,112
	888	1 076	9,5	36	790	885	1 080	1 180	31,5	8	-	0,117
800	889	990	6	45,7	823	915	970	1 037	2,9	5	0,126	0,106
	913	1 047	7,5	25	828	910	1 050	1 122	22,3	6	-	0,111
	947	1 133	9,5	37	840	945	1 135	1 240	32,1	8	-	0,115
850	940	1 053	6	35,9	873	960	1 025	1 097	2,9	5	0,135	0,098
	968	1 113	7,5	27	878	965	1 115	1 192	24,1	6	-	0,124
	1 020	1 200	12	40	898	1 015	1 205	1 312	33,5	10	-	0,11
900	989	1 113	6	20	923	985	1 115	1 157	18,4	5	-	0,132
	1 008	1 172	7,5	45,8	928	1 050	1 130	1 252	3,4	6	0,124	0,1
950	1 044	1 167	7,5	35	978	1 080	1 145	1 222	3,1	6	0,134	0,098
	1 080	1 240	7,5	30	978	1 075	1 245	1 322	26,2	6	-	0,116
1 000	1 136	1 294	7,5	30	1 028	1 135	1 295	1 392	26,7	6	-	0,114
	1 179	1 401	12	46	1 048	1 175	1 405	1 532	38,6	10	-	0,105
1 060	1 175	1 323	7,5	25	1 088	1 170	1 325	1 372	23,4	6	-	0,142
1 180	1 311	1 457	7,5	44,4	1 208	1 335	1 425	1 512	4,1	6	0,137	0,097
1 250	1 397	1 613	9,5	37	1 284	1 395	1 615	1 716	33,9	8	-	0,126

¹⁾ Permissible axial displacement from normal position of one bearing ring relative to the other (→ page 787)

²⁾ Minimum width of free space for bearings with cage in normal position (→ page 792)

Sealed CARB toroidal roller bearings
d 50 – 180 mm

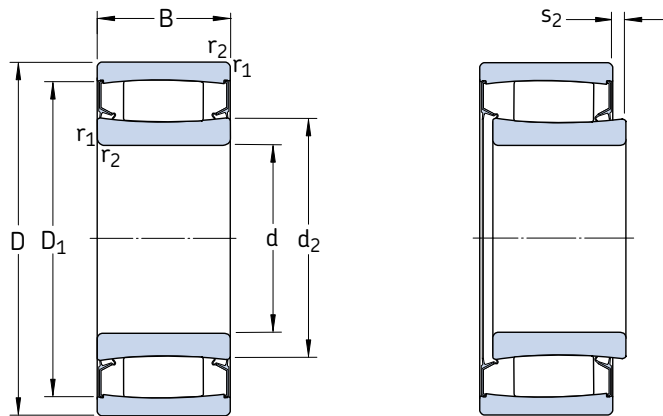

Principal dimensions			Basic load ratings		Fatigue load limit P_u	Limiting speed	Mass	Designation
d	D	B	dynamic C	static C_0				
mm			kN		kN	r/min	kg	–
50	72	40	140	224	24,5	200	0,56	* C 6910-2CS5V ¹⁾
60	85	45	150	240	26,5	170	0,83	* C 6912-2CS5V ¹⁾
65	100	35	102	173	19	150	1,10	* C 4013-2CS5V
75	105	54	204	325	37,5	140	1,40	* C 6915-2CS5V
	115	40	143	193	23,2	130	1,40	* C 4015-2CS5V ¹⁾
90	125	46	224	400	44	110	1,75	* C 5918-2CS5V
100	150	50	310	450	50	95	2,90	* C 4020-2CS5V ¹⁾
	165	65	475	655	69,5	90	5,20	* C 4120-2CS5V ¹⁾
110	170	60	415	585	63	85	4,60	* C 4022-2CS5V ¹⁾
	180	69	500	710	75	85	6,60	* C 4122-2CS5V
120	180	60	430	640	67	80	5,10	* C 4024-2CS5V
	200	80	710	1 000	100	75	9,70	* C 4124-2CS5V ¹⁾
130	200	69	550	830	85	70	7,50	* C 4026-2CS5V
	210	80	750	1 100	108	70	10,5	* C 4126-2CS5V
140	210	69	570	900	88	67	7,90	* C 4028-2CS5V ¹⁾
	225	85	780	1 200	116	63	12,5	* C 4128-2CS5V
150	225	75	585	965	93	63	10,0	* C 4030-2CS5V
	250	100	1 220	1 860	173	60	20,5	* C 4130-2CS5V ¹⁾
160	240	80	655	1 100	104	60	12,0	* C 4032-2CS5V ¹⁾
	270	109	1 460	2 160	200	53	26,0	* C 4132-2CS5V ¹⁾
170	260	90	965	1 630	150	53	17,0	* C 4034-2CS5V ¹⁾
	280	109	1 530	2 280	208	53	27,0	* C 4134-2CS5V ¹⁾
180	280	100	1 320	2 120	193	53	23,5	* C 4036-2CS5V ¹⁾
	300	118	1 760	2 700	240	48	35,0	* C 4136-2CS5V ¹⁾

* SKF Explorer bearing

¹⁾Please check availability of the bearing before incorporating it in a bearing arrangement design

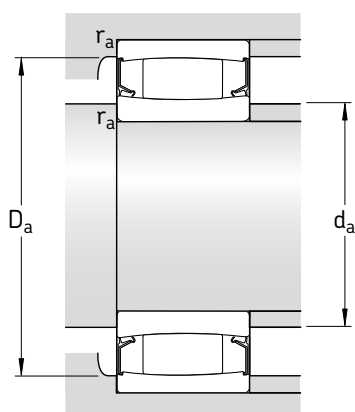

Dimensions					Abutment and fillet dimensions				Calculation factors	
d	d ₂ ~	D ₁ ~	r _{1,2} min	s ₂ ¹⁾ ~	d _a min	d _a max	D _a max	r _a max	k ₁	k ₂
mm					mm				-	
50	57,6	64,9	0,6	2,8	53,2	57	68,8	0,6	0,113	0,091
60	68	75,3	1	5,4	64,6	67	80,4	1	0,128	0,083
65	78,6	87,5	1,1	5,9	71	78	94	1	0,071	0,181
75	83,6 88,5	95,5 104	1 1,1	7,1 7,3	79,6 81	83 88	100 111	1 1	0,073 0,210	0,154 0,063
90	102	113	1,1	4,5	96	101	119	1	0,089	0,131
100	114 120	136 148	1,5 2	6,2 7,3	107 111	113 119	143 154	1,5 2	0,145 0,09	0,083 0,125
110	128 130	155 160	2 2	7,9 8,2	119 121	127 129	161 169	2 2	0,142 0,086	0,083 0,133
120	140 140	164 176	2 2	7,5 8,2	129 131	139 139	171 189	2 2	0,085 0,126	0,142 0,087
130	152 153	182 190	2 2	8,2 7,5	139 141	151 152	191 199	2 2	0,089 0,09	0,133 0,126
140	163 167	193 204	2 2,1	8,7 8,9	149 152	162 166	201 213	2 2	0,133 0,086	0,089 0,134
150	175 179	204 221	2,1 2,1	10,8 6,4	161 162	174 178	214 238	2 2	0,084 0,103	0,144 0,103
160	188 190	218 241	2,1 2,1	11,4 6,7	170 172	187 189	230 258	2 2	0,154 0,101	0,079 0,105
170	201 200	237 251	2,1 2,1	9 6,7	180 182	199 198	250 268	2 2	0,116 0,101	0,097 0,106
180	204 211	246 265	2,1 3	6,4 6,4	190 194	202 209	270 286	2 2,5	0,103 0,095	0,105 0,11

¹⁾ Permissible axial displacement from normal position of one bearing ring relative to the other (→ page 787)

Sealed CARB toroidal roller bearings
d 190 – 200 mm

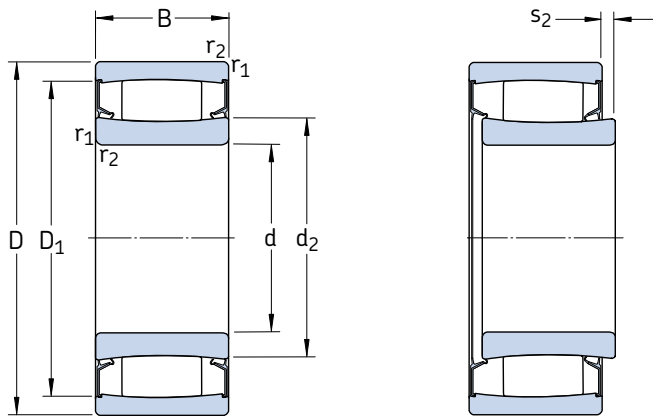

Principal dimensions			Basic load ratings		Fatigue load limit P_u	Limiting speed	Mass	Designation
d	D	B	dynamic C	static C_0				
mm			kN		kN	r/min	kg	–
190	290	100	1 370	2 320	204	48	24,5	* C 4038-2CS5V ¹⁾
	320	128	2 040	3 150	275	45	43,5	* C 4138-2CS5V ¹⁾
200	310	109	1 630	2 650	232	45	31,0	* C 4040-2CS5V ¹⁾
	340	140	2 360	3 650	315	43	54,5	* C 4140-2CS5V ¹⁾

* SKF Explorer bearing

¹⁾ Please check availability of the bearing before incorporating it in a bearing arrangement design

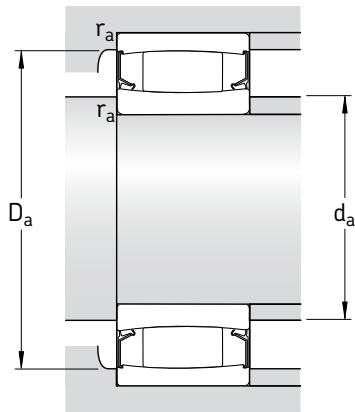

Dimensions					Abutment and fillet dimensions				Calculation factors	
d	d ₂ ~	D ₁ ~	r _{1,2} min	s ₂ ¹⁾ ~	d _a min	d _a max	D _a max	r _a max	k ₁	k ₂
mm					mm				-	
190	221	263	2,1	6,4	200	219	280	2	0,103	0,106
	222	283	3	6,4	204	220	306	2,5	0,094	0,111
200	229	280	2,1	6,7	210	227	300	2	0,101	0,108
	237	301	3	7	214	235	326	2,5	0,092	0,112

¹⁾ Permissible axial displacement from normal position of one bearing ring relative to the other (→ page 787)

**CARB toroidal roller bearings
on adapter sleeve**
d₁ 20 – 70 mm

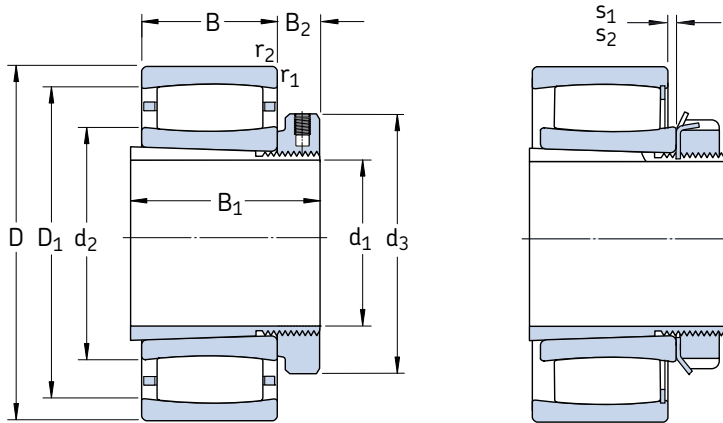

Bearing on E-design
adapter sleeve

Full complement bearing
on standard adapter sleeve

Principal dimensions			Basic load ratings		Fatigue load limit P _u	Speed ratings		Mass Bearing + sleeve	Designations Bearing	Adapter sleeve
d ₁	D	B	dynamic C	static C ₀		Refer- ence speed	Limiting speed			
mm			kN		kN	r/min		kg	–	
20	52	18	44	40	4,55	13 000	18 000	0,24	* C 2205 KTN9 ¹⁾	H 305 E
	52	18	50	48	5,5	–	7 000	0,25	* C 2205 KV ¹⁾	H 305 E
25	62	20	69,5	62	7,2	11 000	15 000	0,37	* C 2206 KTN9	H 306 E
	62	20	76,5	71	8,3	–	6 000	0,39	* C 2206 KV	H 306 E
30	72	23	83	80	9,3	9 500	13 000	0,59	* C 2207 KTN9	H 307 E
	72	23	95	96,5	11,2	–	5 000	0,59	* C 2207 KV	H 307 E
35	80	23	90	86,5	10,2	8 000	11 000	0,69	* C 2208 KTN9	H 308 E
	80	23	102	104	12	–	4 500	0,70	* C 2208 KV	H 308
40	85	23	93	93	10,8	8 000	11 000	0,76	* C 2209 KTN9	H 309 E
	85	23	106	110	12,9	–	4 300	0,79	* C 2209 KV	H 309 E
45	90	23	98	100	11,8	7 000	9 500	0,85	* C 2210 KTN9	H 310 E
	90	23	114	122	14,3	–	3 800	0,89	* C 2210 KV	H 310 E
50	100	25	116	114	13,4	6 700	9 000	1,10	* C 2211 KTN9	H 311 E
	100	25	132	134	16	–	3 400	1,15	* C 2211 KV	H 311 E
55	110	28	143	156	18,3	5 600	7 500	1,45	* C 2212 KTN9	H 312 E
	110	28	166	190	22,4	–	2 800	1,50	* C 2212 KV	H 312
60	120	31	180	180	21,2	5 300	7 500	1,80	* C 2213 KTN9	H 313 E
	120	31	204	216	25,5	–	2 400	1,90	* C 2213 KV	H 313
60	125	31	186	196	23,2	5 000	7 000	2,10	* C 2214 KTN9	H 314 E
	125	31	212	228	27	–	2 400	2,20	* C 2214 KV	H 314
	150	51	405	430	49	3 800	5 000	5,10	* C 2314 K	H 2314
65	130	31	196	208	25,5	4 800	6 700	2,30	* C 2215 K	H 315 E
	130	31	220	240	29	–	2 200	2,40	* C 2215 KV	H 315
	160	55	425	465	52	3 600	4 800	6,20	* C 2315 K	H 2315
70	140	33	220	250	28,5	4 500	6 000	2,90	* C 2216 K	H 316 E
	140	33	255	305	34,5	–	2 000	3,00	* C 2216 KV	H 316
	170	58	510	550	61	3 400	4 500	7,40	* C 2316 K	H 2316

* SKF Explorer bearing

¹⁾Please check availability of the bearing before incorporating it in a bearing arrangement design

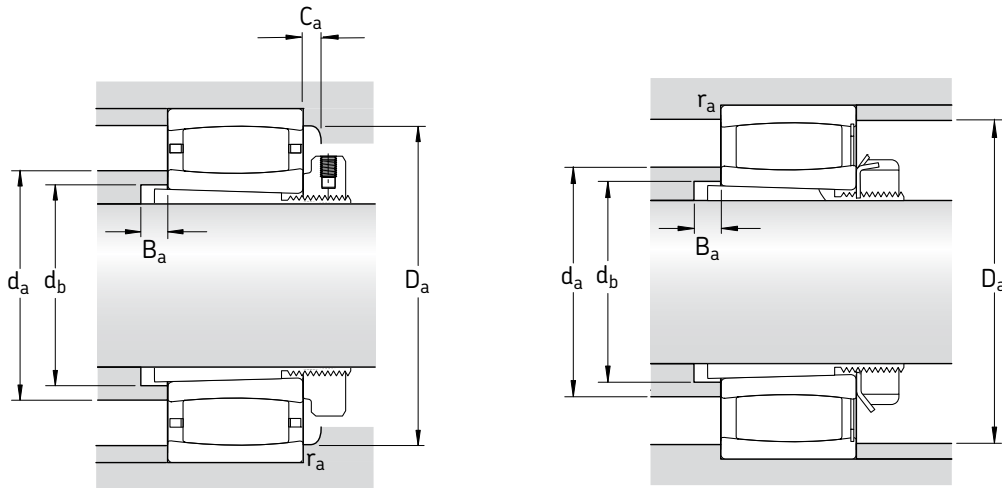

Dimensions									Abutment and fillet dimensions							Calculation factors	
d ₁	d ₂	d ₃	D ₁	B ₁	B ₂	r _{1,2} min	s ₁ ¹⁾	s ₂ ¹⁾	d _a max	d _b min	D _a min	D _a max	B _a min	C _a ²⁾ min	r _a max	k ₁	k ₂
mm									mm							-	
20	32,1	38	43,3	29	10,5	1	5,8	-	32	28	42	46,4	5	0,3	1	0,09	0,126
	32,1	38	43,3	29	10,5	1	5,8	2,8	39	28	-	46,4	5	-	1	0,09	0,126
25	37,4	45	53,1	31	10,5	1	4,5	-	37	33	51	56,4	5	0,3	1	0,101	0,111
	37,4	45	53,1	31	10,5	1	4,5	1,5	49	33	-	56,4	5	-	1	0,101	0,111
30	44,8	52	60,7	35	11,5	1,1	5,7	-	44	39	59	65	5	0,1	1	0,094	0,121
	44,8	52	60,7	35	11,5	1,1	5,7	2,7	57	39	-	65	5	-	1	0,094	0,121
35	52,4	58	69,9	36	13	1,1	7,1	-	52	44	68	73	5	0,3	1	0,093	0,128
	52,4	58	69,9	36	10	1,1	7,1	4,1	66	44	-	73	5	-	1	0,093	0,128
40	55,6	65	73,1	39	13	1,1	7,1	-	55	50	71	78	7	0,3	1	0,095	0,128
	55,6	65	73,1	39	13	1,1	7,1	4,1	69	50	-	78	7	-	1	0,095	0,128
45	61,9	70	79,4	42	14	1,1	7,1	-	61	55	77	83	9	0,8	1	0,097	0,128
	61,9	70	79,4	42	14	1,1	7,1	3,9	73	55	-	83	9	-	1	0,097	0,128
50	65,8	75	86,7	45	14	1,5	8,6	-	65	60	84	91	10	0,3	1,5	0,094	0,133
	65,8	75	86,7	45	14	1,5	8,6	5,4	80	60	-	91	10	-	1,5	0,094	0,133
55	77,1	80	97,9	47	14	1,5	8,5	-	77	65	95	101	9	0,3	1,5	0,1	0,123
	77,1	80	97,9	47	12,5	1,5	8,5	5,3	91	65	-	101	9	-	1,5	0,1	0,123
60	79	85	106	50	15	1,5	9,6	-	79	70	102	111	8	0,2	1,5	0,097	0,127
	79	85	106	50	13,5	1,5	9,6	5,3	97	70	-	111	8	-	1,5	0,097	0,127
	83,7	92	111	52	15	1,5	9,6	-	83	75	107	116	9	0,4	1,5	0,098	0,127
65	83,7	92	111	52	13,5	1,5	9,6	5,3	102	75	-	116	9	-	1,5	0,098	0,127
	91,4	92	130	68	13,5	2,1	9,1	-	105	76	120	138	6	2,2	2	0,11	0,099
	88,5	98	115	55	16	1,5	9,6	-	98	80	110	121	12	1,2	1,5	0,099	0,127
70	88,5	98	115	55	14,5	1,5	9,6	5,3	105	80	-	121	12	-	1,5	0,099	0,127
	98,5	98	135	73	14,5	2,1	13,1	-	110	82	130	148	5	2,2	2	0,103	0,107
	98,1	105	125	59	18	2	9,1	-	105	85	120	129	12	1,2	2	0,104	0,121
70	98,1	105	125	59	17	2	9,1	4,8	115	85	-	129	12	-	2	0,104	0,121
	102	105	145	78	17	2,1	10,1	-	115	88	135	158	6	2,4	2	0,107	0,101

¹⁾ Permissible axial displacement from normal position of one bearing ring relative to the other (→ page 787)

²⁾ Minimum width of free space for bearings with cage in normal position (→ page 792)

**CARB toroidal roller bearings
on adapter sleeve**
d₁ 75 – 140 mm

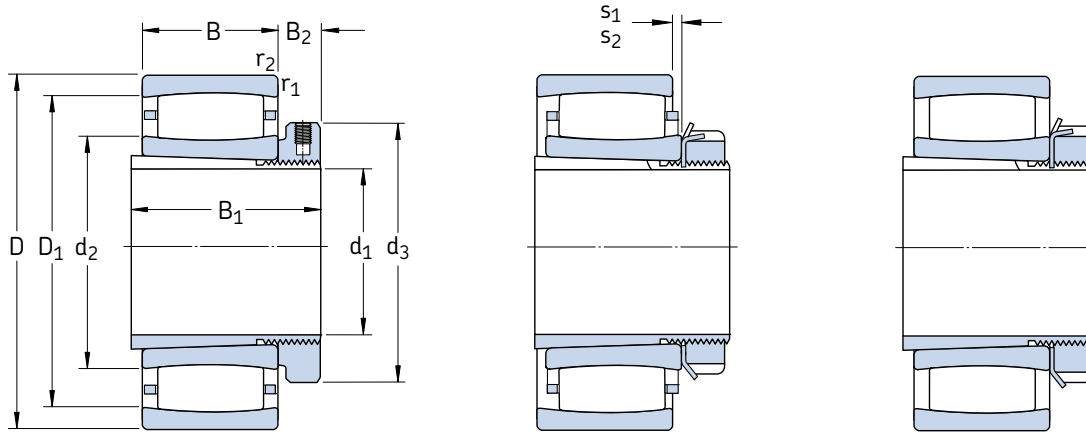

Bearing on E-design
adapter sleeve

Bearing on L-design
or standard adapter sleeve

Full complement bearing
on standard adapter sleeve

Principal dimensions			Basic load ratings		Fatigue load limit P _u	Speed ratings		Mass Bearing + sleeve	Designations Bearing	Adapter sleeve
d ₁	D	B	dynamic C	static C ₀		Refer- ence speed	Limiting speed			
mm			kN		kN	r/min		kg	–	
75	150	36	275	320	36,5	4 300	5 600	3,70	* C 2217 K	H 317 E
	150	36	315	390	44	–	1 800	3,85	* C 2217 KV ¹⁾	H 317
	180	60	540	600	65,5	3 200	4 300	8,50	* C 2317 K	H 2317
80	160	40	325	380	42,5	3 800	5 300	4,50	* C 2218 K	H 318 E
	160	40	365	440	49	–	1 500	4,60	* C 2218 KV ¹⁾	H 318
	190	64	610	695	73,5	2 800	4 000	10,0	* C 2318 K	H 2318
85	170	43	360	400	44	3 800	5 000	5,30	* C 2219 K ¹⁾	H 319 E
	200	67	610	695	73,5	2 800	4 000	11,5	* C 2319 K	H 2319
90	165	52	475	655	69,5	–	1 300	6,10	* C 3120 KV	H 3120 E
	180	46	415	465	47,5	3 600	4 800	6,30	* C 2220 K	H 320 E
	215	73	800	880	91,5	2 600	3 600	14,5	* C 2320 K	H 2320
100	170	45	355	480	51	3 200	4 500	5,50	* C 3022 K	H 322 E
	200	53	530	620	64	3 200	4 300	8,80	* C 2222 K	H 322 E
110	180	46	375	530	55	3 000	4 000	5,70	* C 3024 K ¹⁾	H 3024 E
	180	46	430	640	67	–	1 400	5,85	* C 3024 KV	H 3024
	215	58	610	710	72	3 000	4 000	8,60	* C 2224 K ¹⁾	H 3124 L
	215	76	750	980	98	2 400	3 200	14,2	* C 3224 K	H 2324 L
115	200	52	390	585	58,5	2 800	3 800	8,70	* C 3026 K ¹⁾	H 3026
	230	64	735	930	93	2 800	3 800	14,0	* C 2226 K	H 3126 L
125	210	53	490	735	72	2 600	3 400	9,30	* C 3028 K ¹⁾	H 3028
	250	68	830	1 060	102	2 400	3 400	17,5	* C 2228 K	H 3128 L
135	225	56	540	850	83	2 400	3 200	12,0	* C 3030 KMB ¹⁾	H 3030 E
	250	80	880	1 290	122	2 000	2 800	20,0	* C 3130 K	H 3130 L
	270	73	980	1 220	116	2 400	3 200	23,0	* C 2230 K	H 3130 L
140	240	60	600	980	93	2 200	3 000	14,5	* C 3032 K ¹⁾	H 3032
	270	86	1 000	1 400	132	2 000	2 600	27,0	* C 3132 K ¹⁾	H 3132 L
	290	104	1 370	1 830	170	1 700	2 400	36,5	* C 3232 K	H 2332 L

* SKF Explorer bearing

¹⁾Please check availability of the bearing before incorporating it in a bearing arrangement design

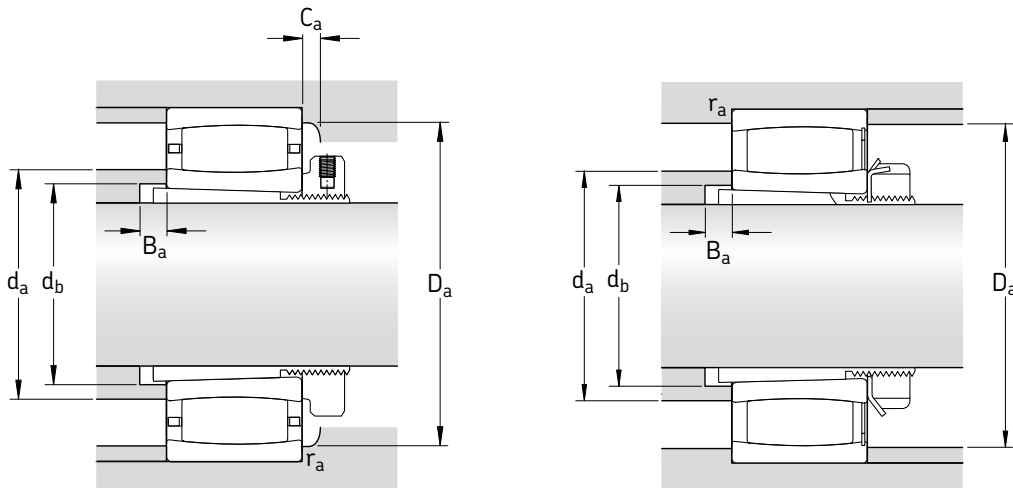

Dimensions									Abutment and fillet dimensions							Calculation factors	
d ₁	d ₂	d ₃	D ₁	B ₁	B ₂	r _{1,2} min	s ₁ ¹⁾	s ₂ ¹⁾	d _a max	d _b min	D _a min	D _a max	B _a min	C _a ²⁾ min	r _a max	k ₁	k ₂
mm									mm							-	
75	104	110	133	63	19	2	7,1	-	110	91	125	139	12	1,3	2	0,114	0,105
	104	110	133	63	18	2	7,1	1,7	115	91	-	139	12	-	2	0,114	0,105
	110	110	153	82	18	3	12,1	-	125	94	145	166	7	2,4	2,5	0,105	0,105
80	112	120	144	65	19	2	9,5	-	120	96	130	149	10	1,4	2	0,104	0,117
	112	120	144	65	18	2	9,5	5,4	125	96	-	149	10	-	2	0,104	0,117
	119	120	166	86	18	3	9,6	-	135	100	155	176	7	2	2,5	0,108	0,101
85	113	125	149	68	20	2,1	10,5	-	112	102	149	158	9	4,2	2	0,114	0,104
	120	125	166	90	19	3	12,6	-	135	105	155	186	7	2,1	2,5	0,103	0,106
90	119	130	150	76	20	2	10	4,7	130	106	-	154	6	-	2	0,1	0,112
	118	130	157	71	21	2,1	10,1	-	130	108	150	168	8	0,9	2	0,108	0,11
	126	130	185	97	20	3	11,2	-	150	110	170	201	7	3,2	2,5	0,113	0,096
100	128	145	156	77	21,5	2	9,5	-	127	118	157	160	14	4	2	0,107	0,11
	132	145	176	77	21,5	2,1	11,1	-	150	118	165	188	6	1,9	2	0,113	0,103
110	138	155	166	72	26	2	10,6	-	145	127	160	170	7	0,9	2	0,111	0,109
	138	145	166	72	22	2	10,6	3,8	150	127	-	170	7	-	2	0,111	0,109
	144	145	191	88	22	2,1	13	-	143	128	192	203	11	5,4	2	0,113	0,103
	149	145	190	112	22	2,1	17,1	-	160	131	180	203	17	2,4	2	0,103	0,108
115	154	155	180	80	23	2	16,5	-	152	137	182	190	8	4,4	2	0,123	0,1
	152	155	199	92	23	3	9,6	-	170	138	185	216	8	1,1	2,5	0,113	0,101
125	163	165	194	82	24	2	11	-	161	147	195	200	8	4,7	2	0,102	0,116
	173	165	223	97	24	3	13,7	-	190	149	210	236	8	2,3	2,5	0,109	0,108
135	173	180	204	87	26	2,1	2,8	-	172	158	200	214	8	1,3	2	-	0,108
	182	180	226	111	26	2,1	13,9	-	195	160	215	238	8	2,3	2	0,12	0,092
	177	180	236	111	26	3	11,2	-	200	160	215	256	15	2,5	2,5	0,119	0,096
140	187	190	218	93	27,5	2,1	15	-	186	168	220	229	8	5,1	2	0,115	0,106
	191	190	240	119	27,5	2,1	19	-	190	170	242	258	8	7,5	2	0,099	0,111
	194	190	256	147	27,5	3	19,3	-	215	174	245	276	18	2,6	2,5	0,112	0,096

¹⁾ Permissible axial displacement from normal position of one bearing ring relative to the other (→ page 787)

²⁾ Minimum width of free space for bearings with cage in normal position (→ page 792)

**CARB toroidal roller bearings
on adapter sleeve**
d₁ 150 – 320 mm

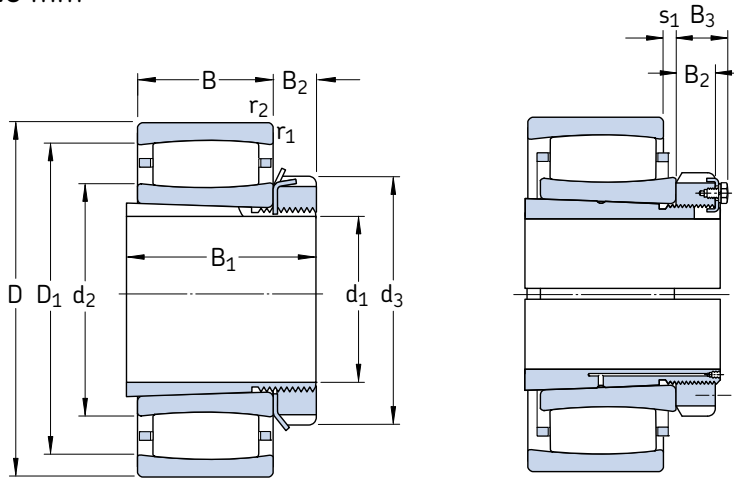

Bearing on L-design
or standard adapter sleeve

Bearing on OH .. H(TL)-design
adapter sleeve

Principal dimensions			Basic load ratings		Fatigue load limit	Speed ratings		Mass	Designations	Adapter sleeve
d ₁	D	B	dynamic C	static C ₀	P _u	Refer-ence speed	Limiting speed	Bearing + sleeve	Bearing	
mm			kN	kN	kN	r/min		kg	–	
150	260	67	750	1 160	108	2 000	2 800	18,0	* C 3034 K ¹⁾	H 3034
	280	88	1 040	1 460	137	1 900	2 600	29,0	* C 3134 K ¹⁾	H 3134 L
	310	86	1 270	1 630	150	2 000	2 600	35,0	* C 2234 K	H 3134 L
160	280	74	880	1 340	125	1 900	2 600	23,0	* C 3036 K	H 3036
	300	96	1 250	1 730	156	1 800	2 400	34,0	* C 3136 K	H 3136 L
	320	112	1 530	2 200	196	1 500	2 000	47,0	* C 3236 K	H 2336
170	290	75	930	1 460	132	1 800	2 400	24,0	* C 3038 K	H 3038
	320	104	1 530	2 200	196	1 600	2 200	44,0	* C 3138 K ¹⁾	H 3138 L
	340	92	1 370	1 730	156	1 800	2 400	43,0	* C 2238 K	H 3138
180	310	82	1 120	1 730	153	1 700	2 400	30,0	* C 3040 K	H 3040
	340	112	1 600	2 320	204	1 500	2 000	50,5	* C 3140 K	H 3140
200	340	90	1 320	2 040	176	1 600	2 200	37,0	* C 3044 K	OH 3044 H
	370	120	1 900	2 900	245	1 400	1 900	64,0	* C 3144 K	OH 3144 HTL
	400	108	2 000	2 500	216	1 500	2 000	69,0	* C 2244 K	OH 3144 H
220	360	92	1 340	2 160	180	1 400	2 000	42,5	* C 3048 K	OH 3048 H
	400	128	2 320	3 450	285	1 300	1 700	77,0	* C 3148 K	OH 3148 HTL
240	400	104	1 760	2 850	232	1 300	1 800	59,0	* C 3052 K	OH 3052 H
	440	144	2 650	4 050	325	1 100	1 500	105	* C 3152 K	OH 3152 HTL
260	420	106	1 860	3 100	250	1 200	1 600	65,0	* C 3056 K	OH 3056 H
	460	146	2 850	4 500	355	1 100	1 400	115	* C 3156 K	OH 3156 HTL
280	460	118	2 160	3 750	290	1 100	1 500	91,0	* C 3060 KM	OH 3060 H
	500	160	3 250	5 200	400	1 000	1 300	150	* C 3160 K	OH 3160 H
300	480	121	2 280	4 000	310	1 000	1 400	95,0	* C 3064 KM	OH 3064 H
	540	176	4 150	6 300	480	950	1 300	190	* C 3164 KM	OH 3164 H
320	520	133	2 900	5 000	375	950	1 300	125	* C 3068 KM	OH 3068 H
	580	190	4 900	7 500	560	850	1 200	235	* C 3168 KM	OH 3168 H

* SKF Explorer bearing

¹⁾Please check availability of the bearing before incorporating it in a bearing arrangement design

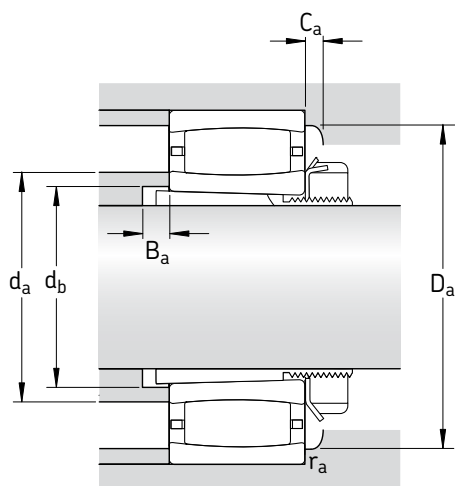

Dimensions									Abutment and fillet dimensions						Calculation factors		
d_1	d_2	d_3	D_1	B_1	B_2	B_3	$r_{1,2}$ min	$s_1^{1)}$	d_a max	d_b min	D_a min	D_a max	B_a min	$C_a^{2)}$ min	r_a max	k_1	k_2
mm									mm						-		
150	200	200	237	101	28,5	-	2,1	12,5	200	179	238	249	8	5,8	2	0,105	0,112
	200	200	249	122	28,5	-	2,1	21	200	180	250	268	8	7,6	2	0,101	0,109
	209	200	274	122	28,5	-	4	16,4	230	180	255	293	10	3	3	0,114	0,1
160	209	210	251	109	29,5	-	2,1	15,1	220	189	240	269	8	2	2	0,112	0,105
	210	210	266	131	29,5	-	3	23,2	230	191	255	286	8	2,2	2,5	0,102	0,111
	228	230	289	161	30	-	4	27,3	245	195	275	303	22	3,2	3	0,107	0,104
170	225	220	266	112	30,5	-	2,1	16,1	235	199	255	279	9	1,9	2	0,113	0,107
	228	220	289	141	30,5	-	3	19	227	202	290	306	9	9,1	2,5	0,096	0,113
	224	240	296	141	31	-	4	22,5	250	202	275	323	21	1,6	3	0,108	0,108
180	235	240	285	120	31,5	-	2,1	15,2	250	210	275	299	9	2,9	2	0,123	0,095
	245	250	305	150	32	-	3	27,3	260	212	307	326	9	-	2,5	0,108	0,104
200	257	260	310	126	30	41	3	17,2	270	231	295	327	9	3,1	2,5	0,114	0,104
	268	260	333	161	30	41	4	22,3	290	233	315	353	9	3,5	3	0,114	0,097
	259	280	350	161	35	-	4	20,5	295	233	320	383	21	1,7	3	0,113	0,101
220	276	290	329	133	34	46	3	19,2	290	251	315	347	11	1,3	2,5	0,113	0,106
	281	290	357	172	34	46	4	20,4	305	254	335	383	11	3,7	3	0,116	0,095
240	305	310	367	145	34	46	4	19,3	325	272	350	385	11	3,4	3	0,122	0,096
	314	310	394	190	34	46	4	26,4	340	276	375	423	11	4,1	3	0,115	0,096
260	328	330	389	152	38	50	4	21,3	350	292	375	405	12	1,8	3	0,121	0,098
	336	330	416	195	38	50	5	28,4	360	296	395	440	12	4,1	4	0,115	0,097
280	352	360	417	168	42	54	4	20	375	313	405	445	12	1,7	3	0,123	0,095
	362	380	448	208	40	53	5	30,5	390	318	425	480	12	4,9	4	0,106	0,106
300	376	380	440	171	42	55	4	23,3	395	334	430	465	13	1,8	3	0,121	0,098
	372	400	476	226	42	56	5	26,7	410	338	455	520	13	3,9	4	0,114	0,096
320	402	400	482	187	45	58	5	25,4	430	355	465	502	14	1,9	4	0,12	0,099
	405	440	517	254	55	72	5	25,9	445	360	490	560	14	4,2	4	0,118	0,093

¹⁾ Permissible axial displacement from normal position of one bearing ring relative to the other (→ page 787)

²⁾ Minimum width of free space for bearings with cage in normal position (→ page 792)

**CARB toroidal roller bearings
on adapter sleeve**
d₁ 340 – 530 mm

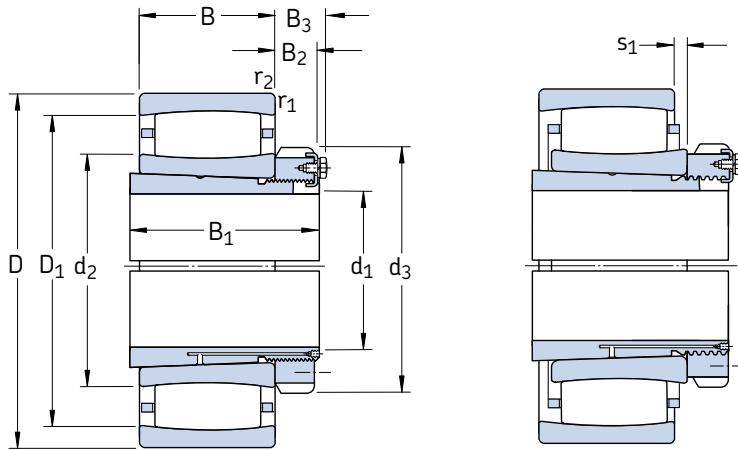

Bearing on OH .. H-design
adapter sleeve

Bearing on OH .. HE-design
adapter sleeve

Principal dimensions			Basic load ratings		Fatigue load limit P _u	Speed ratings		Mass Bearing + sleeve	Designations Bearing	Adapter sleeve
d ₁	D	B	dynamic C	static C ₀		Refer- ence speed	Limiting speed			
mm			kN		kN	r/min		kg	–	
340	480	90	1 760	3 250	250	1 000	1 400	73,0	* C 3972 KM	OH 3972 HE
	540	134	2 900	5 000	375	900	1 200	135	* C 3072 KM	OH 3072 H
	600	192	5 000	8 000	585	800	1 100	250	* C 3172 KM	OH 3172 H
360	520	106	2 120	4 000	300	950	1 300	96,0	* C 3976 KMB ¹⁾	OH 3976 HE
	560	135	3 000	5 200	390	900	1 200	145	* C 3076 KM	OH 3076 H
	620	194	4 550	7 500	540	750	1 000	290	* C 3176 KMB ¹⁾	OH 3176 HE
380	540	106	2 160	4 150	305	900	1 300	105	* C 3980 KMB ¹⁾	OH 3980 HE
	600	148	3 650	6 200	450	800	1 100	175	* C 3080 KM	OH 3080 H
	650	200	5 000	8 650	610	700	950	345	* C 3180 KMB	OH 3180 HE
400	560	106	2 160	4 250	310	850	1 200	105	* C 3984 KM	OH 3984 HE
	620	150	3 800	6 400	465	800	1 100	180	* C 3084 KM	OH 3084 H
	700	224	6 000	10 400	710	670	900	395	* C 3184 KM	OH 3184 H
410	600	118	2 750	5 300	375	800	1 100	155	* C 3988 KMB ¹⁾	OH 3988 HE
	650	157	3 750	6 400	465	750	1 000	250	* C 3088 KMB	OH 3088 HE
	720	226	5 700	9 300	655	670	900	475	* C 3188 KMB ¹⁾	OH 3188 HE
430	620	118	2 700	5 300	375	800	1 100	160	* C 3992 KMB ¹⁾	OH 3992 HE
	680	163	4 000	7 500	510	700	950	270	* C 3092 KM	OH 3092 H
	760	240	6 800	12 000	800	600	800	540	* C 3192 KM	OH 3192 H
450	650	128	3 100	6 100	430	750	1 000	185	* C 3996 KM	OH 3996 H
	700	165	4 050	7 800	530	670	900	275	* C 3096 KM	OH 3096 H
	790	248	6 950	12 500	830	560	750	620	* C 3196 KMB ¹⁾	OH 3196 HE
470	670	128	3 150	6 300	440	700	950	195	* C 39/500 KM	OH 39/500 HE
	720	167	4 250	8 300	560	630	900	305	* C 30/500 KM	OH 30/500 H
	830	264	7 500	12 700	850	530	750	690	* C 31/500 KM	OH 31/500 H
500	710	136	3 550	7 100	490	670	900	230	* C 39/530 KM	OH 39/530 HE
	780	185	5 100	9 500	640	600	800	390	* C 30/530 KM	OH 30/530 H
	870	272	8 800	15 600	1 000	500	670	770	* C 31/530 KM	OH 31/530 H
530	750	140	3 600	7 350	490	600	850	260	* C 39/560 KM	OH 39/560 HE
	820	195	5 600	11 000	720	530	750	440	* C 30/560 KM	OH 30/560 H
	920	280	9 500	17 000	1 100	480	670	930	* C 31/560 KMB ¹⁾	OH 31/560 HE

* SKF Explorer bearing

¹⁾ Please check availability of the bearing before incorporating it in a bearing arrangement design

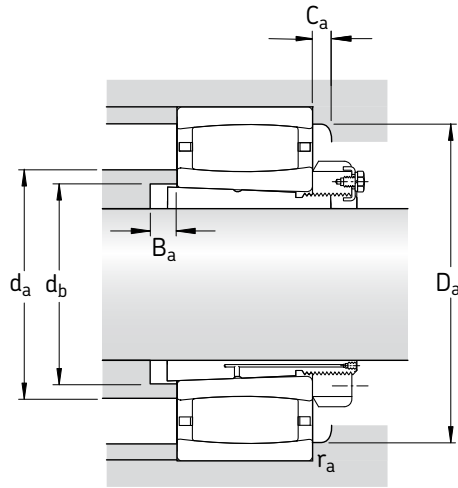

Dimensions									Abutment and fillet dimensions							Calculation factors	
d_1	d_2	d_3	D_1	B_1	B_2	B_3	$r_{1,2}$ min	$s_1^{1)}$	d_a max	d_b min	D_a min	D_a max	B_a min	$C_a^{2)}$ min	r_a max	k_1	k_2
mm									mm							-	
340	394	420	450	144	45	58	3	17,2	405	372	440	467	14	1,6	2,5	0,127	0,104
	417	420	497	188	45	58	5	26,4	445	375	480	522	14	2	4	0,12	0,099
	423	460	537	259	58	75	5	27,9	460	380	510	580	14	3,9	4	0,117	0,094
360	429	450	489	164	48	62	4	10	425	393	490	505	15	9,7	3	-	0,128
	431	450	511	193	48	62	5	27	460	396	495	542	15	2	4	0,12	0,1
	450	490	550	264	60	77	5	19	445	401	555	600	15	16,4	4	-	0,106
380	440	470	500	168	52	66	4	10	435	413	505	525	15	9,7	3	-	0,128
	458	470	553	210	52	66	5	30,6	480	417	525	582	15	2,1	4	0,121	0,099
	485	520	589	272	62	82	6	10,1	480	421	565	624	15	4,4	5	-	0,109
400	462	490	522	168	52	66	4	21,3	480	433	515	545	15	1,8	3	0,132	0,098
	475	490	570	212	52	66	5	32,6	510	437	550	602	16	2,2	4	0,12	0,1
	508	540	618	304	70	90	6	34,8	540	443	595	674	16	3,8	5	0,113	0,098
410	495	520	564	189	60	77	4	11	490	454	565	585	17	10,5	3	-	0,119
	491	520	587	228	60	77	6	19,7	490	458	565	627	17	1,7	5	-	0,105
	514	560	633	307	70	90	6	22	510	463	635	694	17	19,1	5	-	0,102
430	508	540	577	189	60	77	4	11	505	474	580	605	17	10,4	3	-	0,12
	539	540	624	234	60	77	6	33,5	565	478	605	657	17	2,3	5	0,114	0,108
	559	580	679	326	75	95	7,5	51	570	484	655	728	17	4,2	6	0,108	0,105
450	529	560	604	200	60	77	5	20,4	550	496	590	632	18	2	4	0,133	0,095
	555	560	640	237	60	77	6	35,5	580	499	625	677	18	2,3	5	0,113	0,11
	583	620	700	335	75	95	7,5	24	580	505	705	758	18	20,6	6	-	0,104
470	556	580	631	208	68	85	5	20,4	580	516	615	652	18	2	4	0,135	0,095
	572	580	656	247	68	85	6	37,5	600	519	640	697	18	2,3	5	0,113	0,111
	605	630	738	356	80	100	7,5	75,3	655	527	705	798	18	-	6	0,099	0,116
500	578	630	657	216	68	90	5	28,4	600	547	640	692	20	2,2	4	0,129	0,101
	601	630	704	265	68	90	6	35,7	635	551	685	757	20	2,5	5	0,12	0,101
	635	670	781	364	80	105	7,5	44,4	680	558	745	838	20	4,8	6	0,115	0,097
530	622	650	701	227	75	97	5	32,4	645	577	685	732	20	2,3	4	0,128	0,104
	660	650	761	282	75	97	6	45,7	695	582	740	797	20	2,7	5	0,116	0,106
	664	710	808	377	85	110	7,5	28	660	589	810	888	20	23,8	6	-	0,111

¹⁾ Permissible axial displacement from normal position of one bearing ring relative to the other (→ page 787)

²⁾ Minimum width of free space for bearings with cage in normal position (→ page 792)

**CARB toroidal roller bearings
on adapter sleeve**
d₁ 560 – 1 000 mm

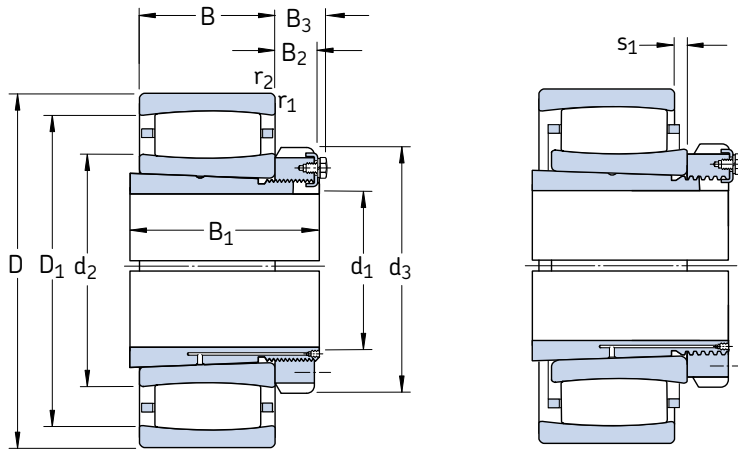

Bearing on OH .. H-design
adapter sleeve

Bearing on OH .. HE-design
adapter sleeve

Principal dimensions			Basic load ratings		Fatigue load limit P _u	Speed ratings		Mass Bearing + sleeve	Designations Bearing	Adapter sleeve
d ₁	D	B	dynamic C	static C ₀		Refer- ence speed	Limiting speed			
mm			kN		kN	r/min		kg	–	
560	800	150	4 000	8 800	570	560	750	325	* C 39/600 KM	OH 39/600 HE
	870	200	6 300	12 200	780	500	700	520	* C 30/600 KM	OH 30/600 H
	980	300	10 200	18 000	1 120	430	600	1 100	* C 31/600 KMB ¹⁾	OH 31/600 HE
600	850	165	4 650	10 000	640	530	700	420	* C 39/630 KM	OH 39/630 HE
	920	212	6 800	12 900	830	480	670	635	* C 30/630 KM	OH 30/630 H
	1 030	315	12 200	22 000	1 370	400	560	1 280	* C 31/630 KMB ¹⁾	OH 31/630 HE
630	900	170	4 900	11 200	695	480	630	455	* C 39/670 KM	OH 39/670 H
	980	230	8 150	16 300	1 000	430	600	750	* C 30/670 KM	OH 30/670 H
	1 090	336	12 000	22 000	1 320	380	530	1 550	* C 31/670 KMB ¹⁾	OH 31/670 HE
670	950	180	6 000	12 500	780	450	630	520	* C 39/710 KM	OH 39/710 HE
	1 030	236	8 800	17 300	1 060	400	560	865	* C 30/710 KM	OH 30/710 H
	1 150	345	12 700	24 000	1 430	360	480	1 800	* C 31/710 KMB ¹⁾	OH 31/710 HE
710	1 000	185	6 100	13 400	815	430	560	590	* C 39/750 KM	OH 39/750 HE
	1 090	250	9 000	18 000	1 100	380	530	1 000	* C 30/750 KMB ¹⁾	OH 30/750 HE
	1 220	365	16 000	30 500	1 800	320	450	2 150	* C 31/750 KMB ¹⁾	OH 31/750 HE
750	1 060	195	6 400	14 600	865	380	530	715	* C 39/800 KM	OH 39/800 HE
	1 150	258	9 150	18 600	1 120	360	480	1 150	* C 30/800 KMB ¹⁾	OH 30/800 HE
	1 280	375	15 600	30 500	1 760	300	400	2 400	* C 31/800 KMB ¹⁾	OH 31/800 HE
800	1 120	200	7 350	16 300	965	360	480	785	* C 39/850 KM	OH 39/850 HE
	1 220	272	11 200	24 000	1 370	320	430	1 050	* C 30/850 KMB ¹⁾	OH 30/850 HE
	1 360	400	16 000	32 000	1 830	280	380	2 260	* C 31/850 KMB ¹⁾	OH 31/850 HE
850	1 180	206	8 150	18 000	1 060	340	450	900	* C 39/900 KMB ¹⁾	OH 39/900 HE
	1 280	280	12 700	26 500	1 530	300	400	1 520	* C 30/900 KM	OH 30/900 H
900	1 250	224	9 300	22 000	1 250	300	430	1 100	* C 39/950 KM	OH 39/950 HE
	1 360	300	12 900	27 500	1 560	280	380	1 800	* C 30/950 KMB ¹⁾	OH 30/950 HE
950	1 420	308	13 400	29 000	1 630	260	340	2 000	* C 30/1000 KMB ¹⁾	OH 30/1000 HE
	1 580	462	22 800	45 500	2 500	220	300	4 300	* C 31/1000 KMB ¹⁾	OH 31/1000 HE
1 000	1 400	250	12 500	29 000	1 600	260	340	1 500	* C 39/1060 KMB ¹⁾	OH 39/1060 HE

* SKF Explorer bearing

¹⁾ Please check availability of the bearing before incorporating it in a bearing arrangement design

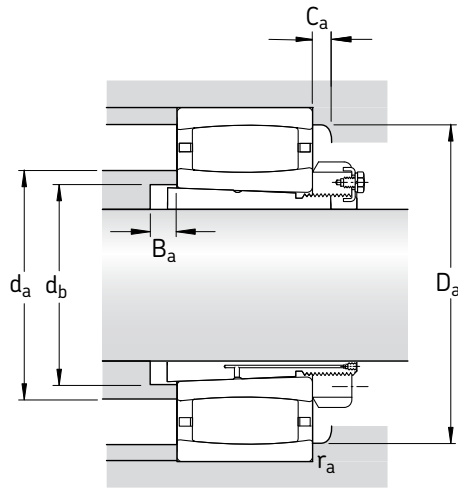

Dimensions									Abutment and fillet dimensions						Calculation factors		
d_1	d_2	d_3	D_1	B_1	B_2	B_3	$r_{1,2}$	$s_1^{1)}$	d_a	d_b	D_a	D_a	B_a	$C_a^{2)}$	r_a	k_1	k_2
mm									mm						-		
560	666	700	744	239	75	97	5	32,4	685	619	725	782	22	2,4	4	0,131	0,1
	692	700	805	289	75	97	6	35,9	725	623	775	847	22	2,7	5	0,125	0,098
	710	750	870	399	85	110	7,5	30	705	632	875	948	22	25,4	6	-	0,105
600	700	730	784	254	75	97	6	35,5	720	650	770	827	22	2,4	5	0,121	0,11
	717	730	840	301	75	97	7,5	48,1	755	654	810	892	22	2,9	6	0,118	0,104
	749	800	919	424	95	120	7,5	31	745	663	920	998	22	26,8	6	-	0,109
630	764	780	848	264	80	102	6	40,5	765	691	830	877	22	2,5	5	0,121	0,113
	775	780	904	324	80	102	7,5	41,1	820	696	875	952	22	2,9	6	0,121	0,101
	797	850	963	456	106	131	7,5	33	795	705	965	1058	22	28	6	-	0,104
670	773	830	877	286	90	112	6	30,7	795	732	850	927	26	2,7	5	0,131	0,098
	807	830	945	342	90	112	7,5	47,3	850	736	910	1002	26	3,2	6	0,119	0,104
	848	900	1012	467	106	135	9,5	34	845	745	1015	1110	26	28,6	8	-	0,102
710	830	870	933	291	90	112	6	35,7	855	772	910	977	26	2,7	5	0,131	0,101
	858	870	993	356	90	112	7,5	25	855	778	995	1062	26	21,8	6	-	0,112
	888	950	1076	493	112	141	9,5	36	885	787	1080	1180	26	31,5	8	-	0,117
750	889	920	990	303	90	112	6	45,7	915	825	970	1037	28	2,9	5	0,126	0,106
	913	920	1047	366	90	112	7,5	25	910	829	1050	1122	28	22,3	6	-	0,111
	947	1000	1133	505	112	141	9,5	37	945	838	1135	1240	28	32,1	8	-	0,115
800	940	980	1053	308	90	115	6	35,9	960	876	1025	1097	28	2,9	5	0,135	0,098
	968	980	1113	380	90	115	7,5	27	965	880	1115	1192	28	24,1	6	-	0,124
	1020	1060	1200	536	118	147	12	40	1015	890	1205	1312	28	33,5	10	-	0,11
850	989	1030	1113	326	100	125	6	20	985	924	1115	1157	30	18,4	5	-	0,132
	1008	1030	1172	400	100	125	7,5	45,8	1050	931	1130	1252	30	3,4	6	0,124	0,1
900	1044	1080	1167	344	100	125	7,5	35	1080	976	1145	1222	30	3,1	6	0,134	0,098
	1080	1080	1240	420	100	125	7,5	30	1075	983	1245	1332	30	26,2	6	-	0,116
950	1136	1140	1294	430	100	125	7,5	30	1135	1034	1295	1392	33	26,7	6	-	0,114
	1179	1240	1401	609	125	154	12	46	1175	1047	1405	1532	33	38,6	10	-	0,105
1000	1175	1200	1323	372	100	125	7,5	25	1170	1090	1325	1392	33	23,4	6	-	0,142

¹⁾ Permissible axial displacement from normal position of one bearing ring relative to the other (→ page 787)

²⁾ Minimum width of free space for bearings with cage in normal position (→ page 792)

**CARB toroidal roller bearings
on withdrawal sleeve**
d₁ 35 – 85 mm

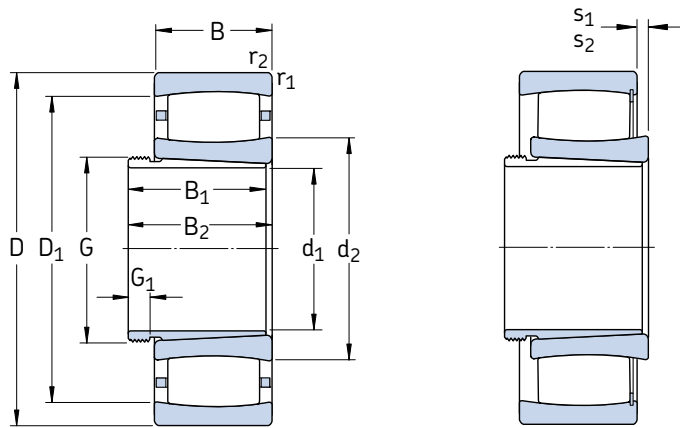

Principal dimensions			Basic load ratings		Fatigue load limit P _u	Speed ratings		Mass Bearing + sleeve	Designations Bearing	Withdrawal sleeve
d ₁	D	B	dynamic C	static C ₀		Refer- ence speed	Limiting speed			
mm			kN		kN	r/min		kg	–	
35	80	23	90	86,5	10,2	8 000	11 000	0,59	* C 2208 KTN9	AH 308
	80	23	102	104	12	–	4 500	0,62	* C 2208 KV	AH 308
40	85	23	93	93	10,8	8 000	11 000	0,67	* C 2209 KTN9	AH 309
	85	23	106	110	12,9	–	4 300	0,70	* C 2209 KV	AH 309
45	90	23	98	100	11,8	7 000	9 500	0,72	* C 2210 KTN9	AHX 310
	90	23	114	122	14,3	–	3 800	0,75	* C 2210 KV	AHX 310
50	100	25	116	114	13,4	6 700	9 000	0,95	* C 2211 KTN9	AHX 311
	100	25	132	134	16	–	3 400	0,97	* C 2211 KV	AHX 311
55	110	28	143	156	18,3	5 600	7 500	1,30	* C 2212 KTN9	AHX 312
	110	28	166	190	22,4	–	2 800	1,35	* C 2212 KV	AHX 312
60	120	31	180	180	21,2	5 300	7 500	1,60	* C 2213 KTN9	AH 313 G
	120	31	204	216	25,5	–	2 400	1,70	* C 2213 KV	AH 313 G
65	125	31	186	196	23,2	5 000	7 000	1,70	* C 2214 KTN9	AH 314 G
	125	31	212	228	27	–	2 400	1,75	* C 2214 KV	AH 314 G
	150	51	405	430	49	3 800	5 000	4,65	* C 2314 K	AHX 2314 G
70	130	31	196	208	25,5	4 800	6 700	1,90	* C 2215 K	AH 315 G
	130	31	220	240	29	–	2 200	1,95	* C 2215 KV	AH 315 G
	160	55	425	465	52	3 600	4 800	5,65	* C 2315 K	AHX 2315 G
75	140	33	220	250	28,5	4 500	6 000	2,35	* C 2216 K	AH 316
	140	33	255	305	34,5	–	2 000	2,45	* C 2216 KV	AH 316
	170	58	510	550	61	3 400	4 500	6,75	* C 2316 K	AHX 2316
80	150	36	275	320	36,5	4 300	5 600	3,00	* C 2217 K	AHX 317
	150	36	315	390	44	–	1 800	3,20	* C 2217 KV ¹⁾	AHX 317
	180	60	540	600	65,5	3 200	4 300	7,90	* C 2317 K	AHX 2317
85	160	40	325	380	42,5	3 800	5 300	3,75	* C 2218 K	AHX 318
	160	40	365	440	49	–	1 500	3,85	* C 2218 KV ¹⁾	AHX 318
	190	64	610	695	73,5	2 800	4 000	9,00	* C 2318 K	AHX 2318

* SKF Explorer bearing

¹⁾Please check availability of the bearing before incorporating it in a bearing arrangement design

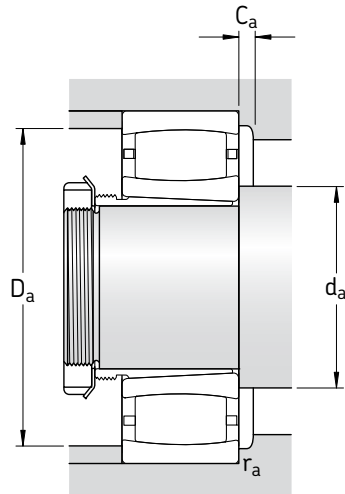

Dimensions											Abutment and fillet dimensions						Calculation factors	
d ₁	d ₂	D ₁	B ₁	B ₂ ¹⁾	G	G ₁	r _{1,2} min	s ₁ ²⁾	s ₂ ²⁾	d _a min	d _a max	D _a min	D _a max	C _a ³⁾ min	r _a max	k ₁	k ₂	
mm											mm						–	
35	52,4	69,9	29	32	M 45x1,5	6	1,1	7,1	–	47	52	68	73	0,3	1	0,093	0,128	
	52,4	69,9	29	32	M 45x1,5	6	1,1	7,1	4,1	47	66	–	73	–	1	0,093	0,128	
40	55,6	73,1	31	34	M 50x1,5	6	1,1	7,1	–	52	55	71	78	0,3	1	0,095	0,128	
	55,6	73,1	31	34	M 50x1,5	6	1,1	7,1	4,1	52	69	–	78	–	1	0,095	0,128	
45	61,9	79,4	35	38	M 55x2	7	1,1	7,1	–	57	61	77	83	0,8	1	0,097	0,128	
	61,9	79,4	35	38	M 55x2	7	1,1	7,1	3,9	57	73	–	83	–	1	0,097	0,128	
50	65,8	86,7	37	40	M 60x2	7	1,5	8,6	–	64	65	84	91	0,3	1,5	0,094	0,133	
	65,8	86,7	37	40	M 60x2	7	1,5	8,6	5,4	64	80	–	91	–	1,5	0,094	0,133	
55	77,1	97,9	40	43	M 65x2	8	1,5	8,5	–	69	77	95	101	0,3	1,5	0,1	0,123	
	77,1	97,9	40	43	M 65x2	8	1,5	8,5	5,3	69	91	–	101	–	1,5	0,1	0,123	
60	79	106	42	45	M 70x2	8	1,5	9,6	–	74	79	102	111	0,2	1,5	0,097	0,127	
	79	106	42	45	M 70x2	8	1,5	9,6	5,3	74	97	–	111	–	1,5	0,097	0,127	
65	83,7	111	43	47	M 75x2	8	1,5	9,6	–	79	83	107	116	0,4	1,5	0,098	0,127	
	83,7	111	43	47	M 75x2	8	1,5	9,6	5,3	79	102	–	116	–	1,5	0,098	0,127	
	91,4	130	64	68	M 75x2	12	2,1	9,1	–	82	105	120	138	2,2	2	0,11	0,099	
70	88,5	115	45	49	M 80x2	8	1,5	9,6	–	84	98	110	121	1,2	1,5	0,099	0,127	
	88,5	115	45	49	M 80x2	8	1,5	9,6	5,3	84	105	–	121	–	1,5	0,099	0,127	
	98,5	135	68	72	M 80x2	12	2,1	13,1	–	87	110	130	148	2,2	2	0,103	0,107	
75	98,1	125	48	52	M 90x2	8	2	9,1	–	91	105	120	129	1,2	2	0,104	0,121	
	98,1	125	48	52	M 90x2	8	2	9,1	4,8	91	115	–	129	–	2	0,104	0,121	
	102	145	71	75	M 90x2	12	2,1	10,1	–	92	115	135	158	2,4	2	0,107	0,101	
80	104	133	52	56	M 95x2	9	2	7,1	–	96	110	125	139	1,3	2	0,114	0,105	
	104	133	52	56	M 95x2	9	2	7,1	1,7	96	115	–	139	–	2	0,114	0,105	
	110	153	74	78	M 95x2	13	3	12,1	–	99	125	145	166	2,4	2,5	0,105	0,105	
85	112	144	53	57	M 100x2	9	2	9,5	–	101	120	130	149	1,4	2	0,104	0,117	
	112	144	53	57	M 100x2	9	2	9,5	5,4	101	125	–	149	–	2	0,104	0,117	
	119	166	79	83	M 100x2	14	3	9,6	–	104	135	155	176	2	2,5	0,108	0,101	

¹⁾ Width before sleeve is driven into bearing bore

²⁾ Permissible axial displacement from normal position of one bearing ring relative to the other (→ page 787)

³⁾ Minimum width of free space for bearings with cage in normal position (→ page 792)

**CARB toroidal roller bearings
on withdrawal sleeve**
d₁ 90 – 145 mm

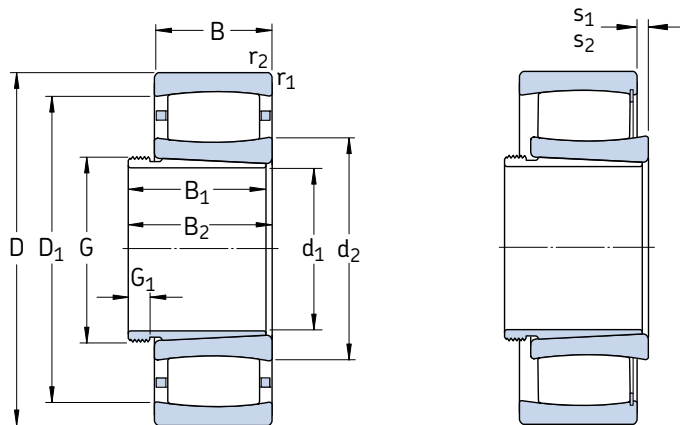

Principal dimensions			Basic load ratings		Fatigue load limit P _u	Speed ratings		Mass Bearing + sleeve	Designations Bearing	Withdrawal sleeve
d ₁	D	B	dynamic C	static C ₀		Reference speed	Limiting speed			
mm			kN		kN	r/min		kg	–	
90	170	43	360	400	44	3 800	5 000	4,50	* C 2219 K ¹⁾	AHX 319
	200	67	610	695	73,5	2 800	4 000	11,0	* C 2319 K	AHX 2319
95	165	52	475	655	69,5	–	1 300	5,00	* C 3120 KV	AHX 3120
	180	46	415	465	47,5	3 600	4 800	5,30	* C 2220 K	AHX 320
	215	73	800	880	91,5	2 600	3 600	13,5	* C 2320 K	AHX 2320
105	170	45	355	480	51	3 200	4 500	4,25	* C 3022 K ¹⁾	AHX 3122
	180	69	670	1 000	102	–	900	7,75	* C 4122 K30V	AH 24122
	200	53	530	620	64	3 200	4 300	7,65	* C 2222 K	AHX 3122
115	180	46	375	530	55	3 000	4 000	4,60	* C 3024 K ¹⁾	AHX 3024
	180	46	430	640	67	–	1 400	4,75	* C 3024 KV	AHX 3024
	180	60	530	880	90	–	1 100	6,20	* C 4024 K30V	AH 24024
	200	80	780	1 120	114	–	750	11,5	* C 4124 K30V ¹⁾	AH 24124
	215	58	610	710	72	3 000	4 000	9,50	* C 2224 K ¹⁾	AHX 3124
	215	76	750	980	98	2 400	3 200	13,0	* C 3224 K	AHX 3224 G
125	200	52	390	585	58,5	2 800	3 800	6,80	* C 3026 K ¹⁾	AHX 3026
	200	69	620	930	91,5	1 900	2 800	8,70	* C 4026 K30	AH 24026
	200	69	720	1 120	112	–	850	8,90	* C 4026 K30V	AH 24026
	210	80	750	1 100	108	–	670	11,5	* C 4126 K30V/VE240	AH 24126
	230	64	735	930	93	2 800	3 800	12,0	* C 2226 K	AHX 3126
135	210	53	490	735	72	2 600	3 400	7,30	* C 3028 K ¹⁾	AHX 3028
	210	69	750	1 220	118	–	800	9,50	* C 4028 K30V	AH 24028
	225	85	1 000	1 600	153	–	630	15,5	* C 4128 K30V	AH 24128
	250	68	830	1 060	102	2 400	3 400	15,5	* C 2228 K	AHX 3128
145	225	56	540	850	83	2 400	3 200	9,40	* C 3030 KMB ¹⁾	AHX 3030
	225	75	780	1 320	125	–	750	11,5	* C 4030 K30V	AH 24030
	250	80	880	1 290	122	2 000	2 800	16,5	* C 3130 K	AHX 3130 G
	250	100	1 220	1 860	173	–	450	22,0	* C 4130 K30V ¹⁾	AH 24130
	270	73	980	1 220	116	2 400	3 200	19,0	* C 2230 K	AHX 3130 G

* SKF Explorer bearing

¹⁾ Please check availability of the bearing before incorporating it in a bearing arrangement design

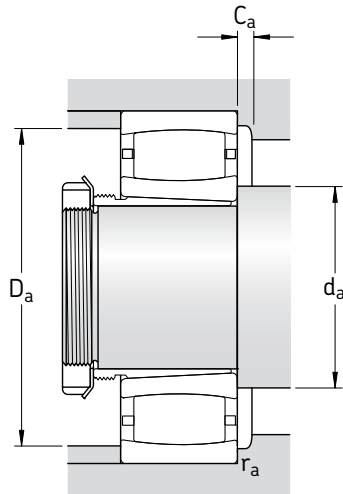

Dimensions											Abutment and fillet dimensions						Calculation factors	
d ₁	d ₂	D ₁	B ₁	B ₂ ¹⁾	G	G ₁	r _{1,2} min	s ₁ ²⁾	s ₂ ²⁾	d _a min	d _a max	D _a min	D _a max	C _a ³⁾ min	r _a max	k ₁	k ₂	
mm											mm						–	
90	113	149	57	61	M 105x2	10	2,1	10,5	–	107	112	149	158	4,2	2	0,114	0,104	
	120	166	85	89	M 105x2	16	3	12,6	–	109	135	155	186	2,1	2,5	0,103	0,106	
95	119	150	64	68	M 110x2	11	2	10	4,7	111	130	–	154	–	2	0,1	0,112	
	118	157	59	63	M 110x2	10	2,1	10,1	–	112	130	150	168	0,9	2	0,108	0,11	
	126	185	90	94	M 110x2	16	3	11,2	–	114	150	170	201	3,2	2,5	0,113	0,096	
105	128	156	68	72	M 120x2	11	2	9,5	–	119	127	157	161	4	2	0,107	0,11	
	132	163	82	91	M 115x2	13	2	11,4	4,6	120	145	–	170	–	2	0,111	0,097	
	132	176	68	72	M 120x2	11	2,1	11,1	–	122	150	165	188	1,9	2	0,113	0,103	
115	138	166	60	64	M 130x2	13	2	10,6	–	129	145	160	171	0,9	2	0,111	0,109	
	138	166	60	64	M 130x2	13	2	10,6	3,8	129	150	–	171	–	2	0,111	0,109	
	140	164	73	82	M 125x2	13	2	12	5,2	129	150	–	171	–	2	0,109	0,103	
	140	176	93	102	M 130x2	13	2	18	11,2	131	140	–	189	–	2	0,103	0,103	
	144	191	75	79	M 130x2	12	2,1	13	–	132	143	192	203	5,4	2	0,113	0,103	
	149	190	90	94	M 130x2	13	2,1	17,1	–	132	160	180	203	2,4	2	0,103	0,108	
125	154	180	67	71	M 140x2	14	2	16,5	–	139	152	182	191	4,4	2	0,123	0,1	
	149	181	83	93	M 140x2	14	2	11,4	–	139	155	175	191	1,9	2	0,113	0,097	
	149	181	83	93	M 135x2	14	2	11,4	4,6	139	165	–	191	–	2	0,113	0,097	
	153	190	94	104	M 140x2	14	2	9,7	9,7	141	170	–	199	–	2	0,09	0,126	
	152	199	78	82	M 140x2	12	3	9,6	–	144	170	185	216	1,1	2,5	0,113	0,101	
135	163	194	68	73	M 150x2	14	2	11	–	149	161	195	201	4,7	2	0,102	0,116	
	161	193	83	93	M 145x2	14	2	11,4	5,9	149	175	–	201	–	2	0,115	0,097	
	167	203	99	109	M 150x2	14	2,1	12	5,2	151	185	–	214	–	2	0,111	0,097	
	173	223	83	88	M 150x2	14	3	13,7	–	154	190	210	236	2,3	2,5	0,109	0,108	
145	173	204	72	77	M 160x3	15	2,1	2,8	–	161	172	200	214	1,3	2	–	0,108	
	173	204	90	101	M 155x3	15	2,1	17,4	10,6	161	185	–	214	–	2	0,107	0,106	
	182	226	96	101	M 160x3	15	2,1	13,9	–	162	195	215	238	2,3	2	0,12	0,092	
	179	222	115	126	M 160x3	15	2,1	20	10,1	162	175	–	228	–	2	0,103	0,103	
	177	236	96	101	M 160x3	15	3	11,2	–	164	200	215	256	2,5	2,5	0,119	0,096	

¹⁾ Width before sleeve is driven into bearing bore

²⁾ Permissible axial displacement from normal position of one bearing ring relative to the other (→ page 787)

³⁾ Minimum width of free space for bearings with cage in normal position (→ page 792)

**CARB toroidal roller bearings
on withdrawal sleeve**
d₁ 150 – 220 mm

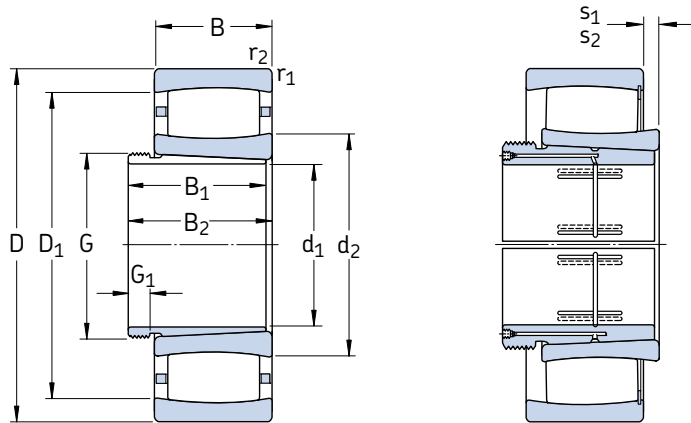

Bearing on withdrawal sleeve
of AH design

Bearing on withdrawal sleeve
of AOH design for oil injection

Principal dimensions			Basic load ratings		Fatigue load limit P _u	Speed ratings		Mass Bearing + sleeve	Designations Bearing	Withdrawal sleeve
d ₁	D	B	dynamic C	static C ₀		Refer- ence speed	Limiting speed			
mm			kN		kN	r/min		kg	–	
150	240	60	600	980	93	2 200	3 000	11,5	* C 3032 K ¹⁾	AH 3032
	240	80	795	1 160	110	1 600	2 400	14,7	* C 4032 K30	AH 24032
	240	80	915	1 460	140	–	600	15,0	* C 4032 K30V	AH 24032
	270	86	1 000	1 400	132	2 000	2 600	23,0	* C 3132 K ¹⁾	AH 3132 G
	270	109	1 460	2 160	200	–	300	29,0	* C 4132 K30V ¹⁾	AH 24132
290	104	1 370	1 830	170	1 700	2 400	31,0	* C 3232 K	AH 3232 G	
160	260	67	750	1 160	108	2 000	2 800	15,0	* C 3034 K ¹⁾	AH 3034
	260	90	1 140	1 860	170	–	480	20,0	* C 4034 K30V	AH 24034
	280	88	1 040	1 460	137	1 900	2 600	24,0	* C 3134 K ¹⁾	AH 3134 G
	280	109	1 530	2 280	208	–	280	30,0	* C 4134 K30V ¹⁾	AH 24134
	310	86	1 270	1 630	150	2 000	2 600	31,0	* C 2234 K	AH 3134 G
170	280	74	880	1 340	125	1 900	2 600	19,0	* C 3036 K	AH 3036
	280	100	1 320	2 120	193	–	430	26,0	* C 4036 K30V	AH 24036
	300	96	1 250	1 730	156	1 800	2 400	30,0	* C 3136 K	AH 3136 G
	300	118	1 760	2 700	240	–	220	38,0	* C 4136 K30V ¹⁾	AH 24136
	320	112	1 530	2 200	196	1 500	2 000	41,5	* C 3236 K	AH 3236 G
180	290	75	930	1 460	132	1 800	2 400	20,5	* C 3038 K	AH 3038 G
	290	100	1 370	2 320	204	–	380	28,0	* C 4038 K30V ¹⁾	AH 24038
	320	104	1 530	2 200	196	1 600	2 200	38,0	* C 3138 K1)	AH 3138 G
	320	128	2 040	3 150	275	–	130	47,5	* C 4138 K30V ¹⁾	AH 24138
	340	92	1 370	1 730	156	1 800	2 400	38,0	* C 2238 K	AH 2238 G
190	310	82	1 120	1 730	153	1 700	2 400	25,5	* C 3040 K	AH 3040 G
	310	109	1 630	2 650	232	–	260	34,5	* C 4040 K30V	AH 24040
	340	112	1 600	2 320	204	1 500	2 000	45,5	* C 3140 K	AH 3140
	340	140	2 360	3 650	315	–	80	59,0	* C 4140 K30V ¹⁾	AH 24140
200	340	90	1 320	2 040	176	1 600	2 200	36,0	* C 3044 K	AOH 3044 G
	340	118	1 930	3 250	275	–	200	48,0	* C 4044 K30V ¹⁾	AOH 24044
	370	120	1 900	2 900	245	1 400	1 900	60,0	* C 3144 K	AOH 3144
	400	108	2 000	2 500	216	1 500	2 000	65,5	* C 2244 K	AOH 2244
220	360	92	1 340	2 160	180	1 400	2 000	39,5	* C 3048 K	AOH 3048
	400	128	2 320	3 450	285	1 300	1 700	75,0	* C 3148 K	AOH 3148

* SKF Explorer bearing

¹⁾ Please check availability of the bearing before incorporating it in a bearing arrangement design

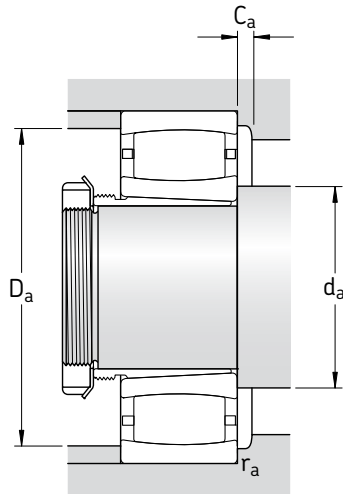

Dimensions										Abutment and fillet dimensions						Calculation factors	
d_1	d_2	D_1	B_1	$B_2^{1)}$	G	G_1	$r_{1,2}$ min	$s_1^{2)}$	$s_2^{2)}$	d_a min	d_a max	D_a min	D_a max	$C_a^{3)}$ min	r_a max	k_1	k_2
mm										mm						-	
150	187	218	77	82	M 170×3	16	2,1	15	-	171	186	220	229	5,1	2	0,115	0,106
	181	217	95	106	M 170×3	15	2,1	18,1	-	171	190	210	229	2,2	2	0,109	0,103
	181	217	95	106	M 170×3	15	2,1	18,1	8,2	171	195	-	229	-	2	0,109	0,103
	191	240	103	108	M 170×3	16	2,1	19	-	172	190	242	258	7,5	2	0,099	0,111
	190	241	124	135	M 170×3	15	2,1	21	11,1	172	190	-	258	-	2	0,101	0,105
194	256	124	130	M 170×3	20	3	19,3	-	174	215	245	276	2,6	2,5	0,112	0,096	
160	200	237	85	90	M 180×3	17	2,1	12,5	-	181	200	238	249	5,8	2	0,105	0,112
	195	235	106	117	M 180×3	16	2,1	17,1	7,2	181	215	-	249	-	2	0,108	0,103
	200	249	104	109	M 180×3	16	2,1	21	-	182	200	250	268	7,6	2	0,101	0,109
	200	251	125	136	M 180×3	16	2,1	21	11,1	182	200	-	268	-	2	0,101	0,106
	209	274	104	109	M 180×3	16	4	16,4	-	187	230	255	293	3	3	0,114	0,1
170	209	251	92	98	M 190×3	17	2,1	15,1	-	191	220	240	269	2	2	0,112	0,105
	203	247	116	127	M 190×3	16	2,1	20,1	10,2	191	225	-	269	-	2	0,107	0,103
	210	266	116	122	M 190×3	19	3	23,2	-	194	230	255	286	2,2	2,5	0,102	0,111
	211	265	134	145	M 190×3	16	3	20	10,1	194	210	-	286	-	2,5	0,095	0,11
	228	289	140	146	M 190×3	24	4	27,3	-	197	245	275	303	3,2	3	0,107	0,104
180	225	266	96	102	M 200×3	18	2,1	16,1	-	201	235	255	279	1,9	2	0,113	0,107
	220	263	118	131	M 200×3	18	2,1	20	10,1	201	220	-	279	-	2	0,103	0,106
	228	289	125	131	M 200×3	20	3	19	-	204	227	290	306	9,1	2,5	0,096	0,113
	222	284	146	159	M 200×3	18	3	20	10,1	204	220	-	306	-	2,5	0,094	0,111
	224	296	112	117	M 200×3	18	4	22,5	-	207	250	275	323	1,6	3	0,108	0,108
190	235	285	102	108	Tr 210×4	19	2,1	15,2	-	211	250	275	299	2,9	2	0,123	0,095
	229	280	127	140	Tr 210×4	18	2,1	21	11,1	211	225	-	299	-	2	0,11	0,101
	245	305	134	140	Tr 220×4	21	3	27,3	-	214	260	307	326	-	2,5	0,108	0,104
	237	302	158	171	Tr 210×4	18	3	22	12,1	214	235	-	326	-	2,5	0,092	0,112
200	257	310	111	117	Tr 230×4	20	3	17,2	-	233	270	295	327	3,1	2,5	0,114	0,104
	251	306	138	152	Tr 230×4	20	3	20	10,1	233	250	-	327	-	2,5	0,095	0,113
	268	333	145	151	Tr 240×4	23	4	22,3	-	237	290	315	353	3,5	3	0,114	0,097
	259	350	145	151	Tr 240×4	23	4	20,5	-	237	295	320	383	1,7	3	0,113	0,101
220	276	329	116	123	Tr 260×4	21	3	19,2	-	253	290	315	347	1,3	2,5	0,113	0,106
	281	357	154	161	Tr 260×4	25	4	20,4	-	257	305	335	383	3,7	3	0,116	0,095

1) Width before sleeve is driven into bearing bore

2) Permissible axial displacement from normal position of one bearing ring relative the other (→ page 787)

3) Minimum width of free space for bearings with cage in normal position (→ page 792)

**CARB toroidal roller bearings
on withdrawal sleeve**
d₁ 240 – 460 mm

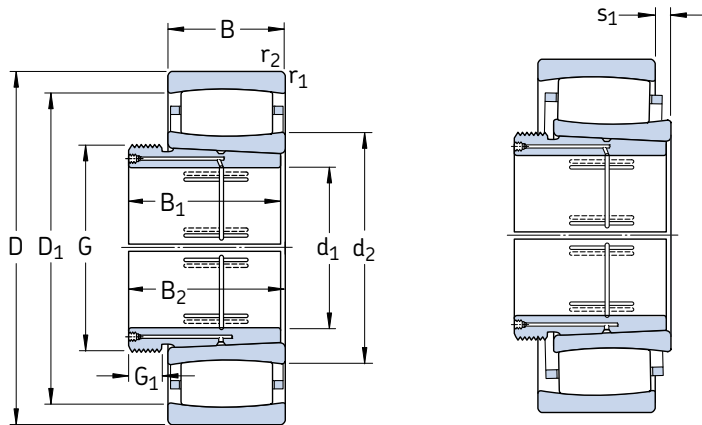

Principal dimensions			Basic load ratings		Fatigue load limit P _u	Speed ratings		Mass Bearing + sleeve	Designations Bearing	Withdrawal sleeve
d ₁	D	B	dynamic C	static C ₀		Refer- ence speed	Limiting speed			
mm			kN		kN	r/min		kg	–	
240	400	104	1 760	2 850	232	1 300	1 800	55,5	* C 3052 K	AOH 3052
	440	144	2 650	4 050	325	1 100	1 500	102	* C 3152 K	AOH 3152 G
260	420	106	1 860	3 100	250	1 200	1 600	61,0	* C 3056 K	AOH 3056
	460	146	2 850	4 500	355	1 100	1 400	110	* C 3156 K	AOH 3156 G
280	460	118	2 160	3 750	290	1 100	1 500	84,0	* C 3060 KM	AOH 3060
	460	160	2 900	4 900	380	850	1 200	110	* C 4060 K30M	AOH 24060 G
	500	160	3 250	5 200	400	1 000	1 300	140	* C 3160 K	AOH 3160 G
300	480	121	2 280	4 000	310	1 000	1 400	93,0	* C 3064 KM	AOH 3064 G
	540	176	4 150	6 300	480	950	1 300	185	* C 3164 KM	AOH 3164 G
320	520	133	2 900	5 000	375	950	1 300	120	* C 3068 KM	AOH 3068 G
	580	190	4 900	7 500	560	850	1 200	230	* C 3168 KM	AOH 3168 G
340	540	134	2 900	5 000	375	900	1 200	125	* C 3072 KM	AOH 3072 G
	600	192	5 000	8 000	585	800	1 100	245	* C 3172 KM	AOH 3172 G
360	560	135	3 000	5 200	390	900	1 200	130	* C 3076 KM	AOH 3076 G
	620	194	4 550	7 500	540	750	1 000	260	* C 3176 KMB ¹⁾	AOH 3176 G
380	600	148	3 650	6 200	450	800	1 100	165	* C 3080 KM	AOH 3080 G
	650	200	5 000	8 650	610	700	950	310	* C 3180 KMB	AOH 3180 G
400	620	150	3 800	6 400	465	850	1 200	175	* C 3084 KM	AOH 3084 G
	700	224	6 000	10 400	710	800	1 100	380	* C 3184 KM	AOH 3184 G
420	650	157	3 750	6 400	465	800	1 100	215	* C 3088 KMB	AOHX 3088 G
	720	226	5 700	9 300	655	670	900	405	* C 3188 KMB ¹⁾	AOHX 3188 G
440	680	163	4 000	7 500	510	700	950	230	* C 3092 KM	AOHX 3092 G
	760	240	6 800	12 000	800	600	800	480	* C 3192 KM	AOHX 3192 G
	760	300	8 300	14 300	950	480	630	585	* C 4192 K30M	AOH 24192
460	700	165	4 050	7 800	530	670	900	245	* C 3096 KM	AOHX 3096 G
	790	248	6 950	12 500	830	560	750	545	* C 3196 KMB ¹⁾	AOHX 3196 G

* SKF Explorer bearing

¹⁾ Please check availability of the bearing before incorporating it in a bearing arrangement design

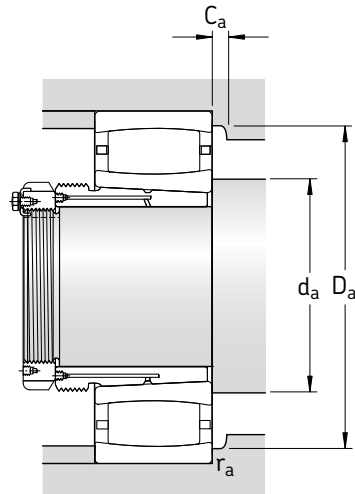

Dimensions									Abutment and fillet dimensions						Calculation factors	
d_1	d_2	D_1	B_1	$B_2^{1)}$	G	G_1	$r_{1,2}$	$s_1^{2)}$	d_a	d_a	D_a	D_a	$C_a^{3)}$	r_a	k_1	k_2
mm									mm						-	
240	305	367	128	135	Tr 280x4	23	4	19,3	275	325	350	385	3,4	3	0,122	0,096
	314	394	172	179	Tr 280x4	26	4	26,4	277	340	375	423	4,1	3	0,115	0,096
260	328	389	131	139	Tr 300x4	24	4	21,3	295	350	375	405	1,8	3	0,121	0,098
	336	416	175	183	Tr 300x5	28	5	28,4	300	360	395	440	4,1	4	0,115	0,097
280	352	417	145	153	Tr 320x5	26	4	20	315	375	405	445	1,7	3	0,123	0,095
	338	409	184	202	Tr 320x5	24	4	30,4	315	360	400	445	2,8	3	0,105	0,106
	362	448	192	200	Tr 320x5	30	5	30,5	320	390	425	480	4,9	4	0,106	0,106
300	376	440	149	157	Tr 340x5	27	4	23,3	335	395	430	465	1,8	3	0,121	0,098
	372	476	209	217	Tr 340x5	31	5	26,7	340	410	455	520	3,9	4	0,114	0,096
320	402	482	162	171	Tr 360x5	28	5	25,4	358	430	465	502	1,9	4	0,12	0,099
	405	517	225	234	Tr 360x5	33	5	25,9	360	445	490	560	4,2	4	0,118	0,093
340	417	497	167	176	Tr 380x5	30	5	26,4	378	445	480	522	2	4	0,12	0,099
	423	537	229	238	Tr 380x5	35	5	27,9	380	460	510	522	3,9	4	0,117	0,094
360	431	511	170	180	Tr 400x5	31	5	27	398	460	495	542	2	4	0,12	0,1
	450	550	232	242	Tr 400x5	36	5	19	400	445	555	600	16,4	4	-	0,106
380	458	553	183	193	Tr 420x5	33	5	30,6	418	480	525	582	2,1	4	0,121	0,099
	485	589	240	250	Tr 420x5	38	6	10,1	426	480	565	624	4,4	5	-	0,109
400	475	570	186	196	Tr 440x5	34	5	32,6	438	510	550	602	2,2	4	0,12	0,1
	508	618	266	276	Tr 440x5	40	6	34,8	446	540	595	674	3,8	5	0,113	0,098
420	491	587	194	205	Tr 460x5	35	6	19,7	463	490	565	627	1,7	5	-	0,105
	514	633	270	281	Tr 460x5	48	6	22	466	510	635	694	19,1	5	-	0,102
440	539	624	202	213	Tr 480x5	37	6	33,5	486	565	605	654	2,3	5	0,114	0,108
	559	679	285	296	Tr 480x6	43	7,5	51	492	570	655	728	4,2	6	0,108	0,105
	540	670	332	355	Tr 480x5	32	7,5	46,2	492	570	655	728	5,6	6	0,111	0,097
460	555	640	205	217	Tr 500x6	38	6	35,5	503	580	625	677	2,3	5	0,113	0,11
	583	700	295	307	Tr 500x6	45	7,5	24	512	580	705	758	20,6	6	-	0,104

1) Width before sleeve is driven into bearing bore

2) Permissible axial displacement from normal position of one bearing ring relative to the other (→ page 787)

3) Minimum width of free space for bearings with cage in normal position (→ page 792)

**CARB toroidal roller bearings
on withdrawal sleeve**
d₁ 480 – 950 mm

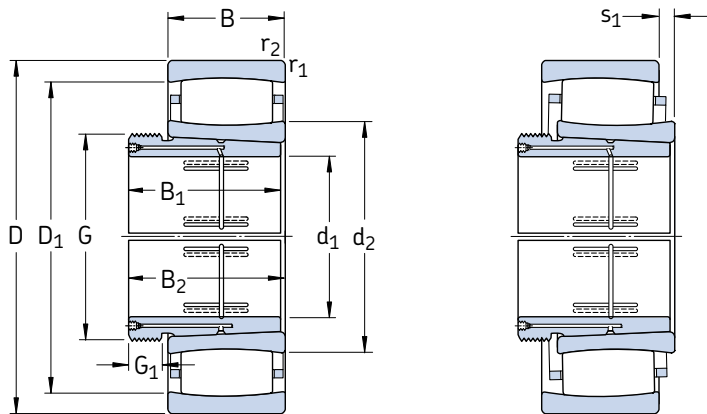

Principal dimensions			Basic load ratings		Fatigue load limit P _u	Speed ratings		Mass Bearing + sleeve	Designations Bearing	Withdrawal sleeve
d ₁	D	B	dynamic C	static C ₀		Refer- ence speed	Limiting speed			
mm			kN		kN	r/min		kg	–	
480	720	167	4 250	8 300	560	630	900	265	*C 30/500 KM	AOHX 30/500 G
	830	264	7 500	12 700	850	530	750	615	*C 31/500 KM	AOHX 31/500 G
	830	325	9 800	17 600	1 140	400	560	775	*C 41/500 K30MB	AOH 241/500
500	780	185	5 100	9 500	640	600	800	355	*C 30/530 KM	AOH 30/530
	870	272	8 800	15 600	1 000	500	670	720	*C 31/530 KM	AOH 31/530
530	820	195	5 600	11 000	720	600	850	415	*C 30/560 KM	AOHX 30/560
	920	280	9 500	17 000	1 100	530	750	855	*C 31/560 KMB ¹⁾	AOH 31/560
570	870	200	6 300	12 200	780	500	700	460	*C 30/600 KM	AOHX 30/600
	980	300	10 200	18 000	1 120	430	600	990	*C 31/600 KMB ¹⁾	AOHX 31/600
600	920	212	6 800	12 900	830	480	670	555	*C 30/630 KM	AOH 30/630
	1 030	315	12 200	22 000	1 370	400	560	1 180	*C 31/630 KMB ¹⁾	AOH 31/630
630	980	230	8 150	16 300	1 000	430	600	705	*C 30/670 KM	AOH 30/670
	1 090	336	12 000	22 000	1 320	380	530	1 410	*C 31/670 KMB ¹⁾	AOHX 31/670
670	1 030	236	8 800	17 300	1 060	450	630	780	*C 30/710 KM	AOHX 30/710
	1 030	315	10 600	21 600	1 290	400	560	1 010	*C 40/710 K30M	AOH 240/710 G
	1 150	345	12 700	24 000	1 430	360	480	1 600	*C 31/710 KMB ¹⁾	AOHX 31/710
710	1 090	250	9 000	18 000	1 100	380	530	920	*C 30/750 KMB ¹⁾	AOH 30/750
	1 220	365	16 000	30 500	1 800	320	450	1 930	*C 31/750 KMB ¹⁾	AOH 31/750
750	1 150	258	9 150	18 600	1 120	360	480	1 060	*C 30/800 KMB ¹⁾	AOH 30/800
	1 280	375	15 600	30 500	1 760	300	400	2 170	*C 31/800 KMB ¹⁾	AOH 31/800
800	1 220	272	11 200	24 000	1 370	320	430	1 280	*C 30/850 KMB ¹⁾	AOH 30/850
	1 360	400	16 000	32 000	1 830	280	380	2 600	*C 31/850 KMB ¹⁾	AOH 31/850
850	1 280	280	12 700	26 500	1 530	300	400	1 400	*C 30/900 KM	AOH 30/900
900	1 360	300	12 900	27 500	1 560	280	380	1 700	*C 30/950 KMB ¹⁾	AOH 30/950
950	1 420	308	13 400	29 000	1 630	260	340	1 880	*C 30/1000 KMB ¹⁾	AOH 30/1000
	1 580	462	22 800	45 500	2 500	220	300	3 950	*C 31/1000 KMB ¹⁾	AOH 31/1000

* SKF Explorer bearing

¹⁾ Please check availability of the bearing before incorporating it in a bearing arrangement design

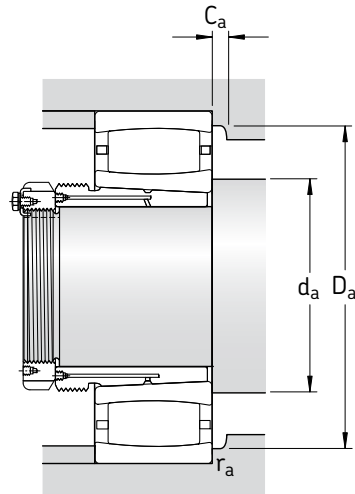

Dimensions									Abutment and fillet dimensions						Calculation factors	
d ₁	d ₂	D ₁	B ₁	B ₂ ¹⁾	G	G ₁	r _{1,2}	s ₁ ²⁾	d _a	d _a	D _a	D _a	C _a ³⁾	r _a	k ₁	k ₂
mm									mm						-	
480	572	656	209	221	Tr 530×6	40	6	37,5	523	600	640	697	2,3	5	0,113	0,111
	605	738	313	325	Tr 530×6	47	7,5	75,3	532	655	705	798	-	6	0,099	0,116
	598	740	360	383	Tr 530×6	35	7,5	16,3	532	595	705	798	5,9	6	-	0,093
500	601	704	230	242	Tr 560×6	45	6	35,7	553	635	685	757	2,5	5	0,12	0,101
	635	781	325	337	Tr 560×6	53	7,5	44,4	562	680	745	838	4,8	6	0,115	0,097
530	660	761	240	252	Tr 600×6	45	6	45,7	583	695	740	793	2,7	5	0,116	0,106
	664	808	335	347	Tr 600×6	55	7,5	28	592	660	810	888	23,8	6	-	0,111
570	692	805	245	259	Tr 630×6	45	6	35,9	623	725	775	847	2,7	5	0,125	0,098
	710	870	355	369	Tr 630×6	55	7,5	30	632	705	875	948	25,4	6	-	0,105
600	717	840	258	272	Tr 670×6	46	7,5	48,1	658	755	810	892	2,9	6	0,118	0,104
	749	919	375	389	Tr 670×6	60	7,5	31	662	745	920	998	26,8	6	-	0,109
630	775	904	280	294	Tr 710×7	50	7,5	41,1	698	820	875	952	2,9	6	0,121	0,101
	797	963	395	409	Tr 710×7	59	7,5	33	702	795	965	1 058	28	6	-	0,104
670	807	945	286	302	Tr 750×7	50	7,5	47,3	738	850	910	1 002	3,2	6	0,119	0,104
	803	935	360	389	Tr 750×7	45	7,5	51,2	738	840	915	1 002	4,4	6	0,113	0,101
	848	1 012	405	421	Tr 750×7	60	9,5	34	750	845	1 015	1 100	28,6	8	-	0,102
710	858	993	300	316	Tr 800×7	50	7,5	25	778	855	995	1 062	21,8	6	-	0,112
	888	1 076	425	441	Tr 800×7	60	9,5	36	790	885	1 080	1 180	31,5	8	-	0,117
750	913	1 047	308	326	Tr 850×7	50	7,5	25	828	910	1 050	1 122	22,3	6	-	0,111
	947	1 133	438	456	Tr 850×7	63	9,5	37	840	945	1 135	1 240	32,1	8	-	0,115
800	968	1 113	325	343	Tr 900×7	53	7,5	27	878	965	1 115	1 192	24,1	6	-	0,124
	1 020	1 200	462	480	Tr 900×7	62	12	40	898	1 015	1 205	1 312	33,5	10	-	0,11
850	1 008	1 172	335	355	Tr 950×8	55	7,5	45,8	928	1 050	1 130	1 252	3,4	6	0,124	0,1
900	1 080	1 240	355	375	Tr 1000×8	55	7,5	30	978	1 075	1 245	1 322	26,2	6	-	0,116
950	1 136	1 294	365	387	Tr 1060×8	57	7,5	30	1 028	1 135	1 295	1 392	26,7	6	-	0,114
	1 179	1 401	525	547	Tr 1060×8	63	12	46	1 048	1 175	1 405	1 532	38,6	10	-	0,105

¹⁾ Width before sleeve is driven into bearing bore

²⁾ Permissible axial displacement from normal position of one bearing ring relative to the other (→ page 787)

³⁾ Minimum width of free space for bearings with cage in normal position (→ page 792)



Thrust ball bearings

Single direction thrust ball bearings	838
Double direction thrust ball bearings	839
Bearing data – general	840
Dimensions.....	840
Tolerances.....	840
Misalignment.....	840
Cages.....	840
Minimum load.....	841
Equivalent dynamic bearing load.....	841
Equivalent static bearing load.....	841
Supplementary designations.....	841
Product tables	842
Single direction thrust ball bearings.....	842
Single direction thrust ball bearings with sphered housing washer.....	852
Double direction thrust ball bearings	856
Double direction thrust ball bearings with sphered housing washers.....	860



Single direction thrust ball bearings

SKF single direction thrust ball bearings consist of a shaft washer, a housing washer and a ball and cage thrust assembly. The bearings are separable so that mounting is simple as the washers and the ball and cage assembly can be mounted separately.

Smaller sizes are available with either a flat seating surface on the housing washer (→ **fig. 1**) or a sphered seating surface (→ **fig. 2**). Bearings with a sphered housing washer can be used together with a sphered seating washer (→ **fig. 3**) to compensate for misalignment between the support surface in the housing and the shaft. Sphered seating washers are available from SKF but must be ordered separately.

Single direction thrust ball bearings, as their name suggests, can accommodate axial loads in one direction and thus locate a shaft axially in one direction. They must not be subjected to any radial load.

Fig. 1

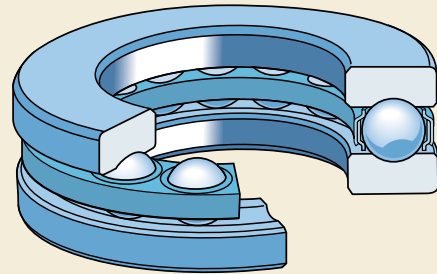

Fig. 2

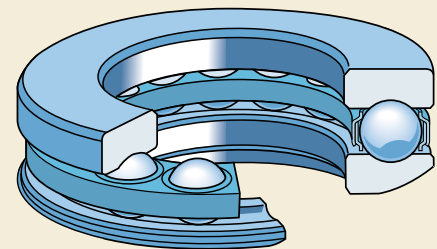
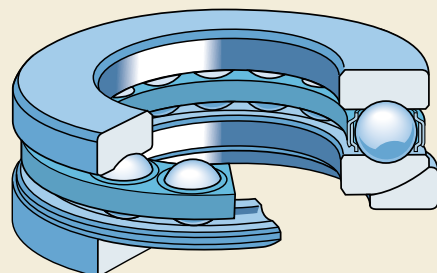

Fig. 3



Double direction thrust ball bearings

SKF double direction thrust ball bearings consist of one shaft washer, two housing washers and two ball and cage thrust assemblies. The bearings are separable so that mounting is simple. The various parts can be mounted separately. The housing washers and ball and cage thrust assemblies are identical to those of the single direction bearings.

Smaller bearings are available with either a flat seating surface on the housing washers (→ **fig. 4**) or with a sphered seating surface (→ **fig. 5**). Bearings with sphered housing washers can be used together with sphered seating washers (→ **fig. 6**) to compensate for misalignment between the housing and shaft. The sphered seating washers are available from SKF, but must be ordered separately.

Double direction thrust ball bearings can accommodate axial loads acting in both directions and can thus serve to axially locate a shaft in both directions. They must not be subjected to any radial load.

Fig. 4

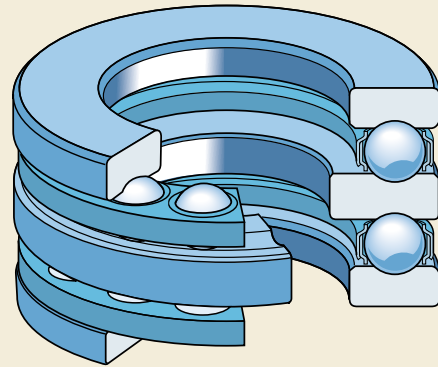

Fig. 5

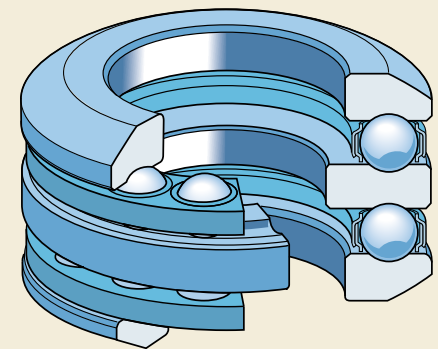
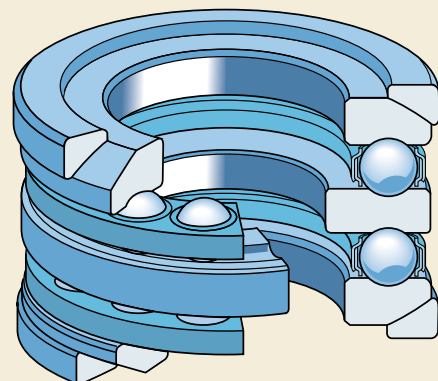

Fig. 6



Bearing data – general

Dimensions

The boundary dimensions of SKF thrust ball bearings with flat or sphered housing washers conform to DIN 711:1988 and DIN 715:1987. The dimensions of the bearings with flat housing washers conform to ISO 104:2002.

The values given for the height H_1 for bearings with sphered housing washer(s) are valid only for SKF bearings with SKF washers.

Tolerances

SKF thrust ball bearings are made to Normal tolerances as standard. Some single direction bearings with flat housing washer are also available with increased accuracy to tolerance class P6 or tolerance class P5 specifications. Contact SKF for availability before ordering.

Normal, P6 and P5 tolerances are in accordance with ISO 199:1997. The values can be found in **table 10** on **page 132**.

Misalignment

Thrust ball bearings with flat housing washers cannot accommodate any misalignment between the shaft and housing or angular misalignment between the support surfaces in the housing and on the shaft.

The bearings with sphered housing washers are generally used with sphered seating washers and can compensate for initial misalignment

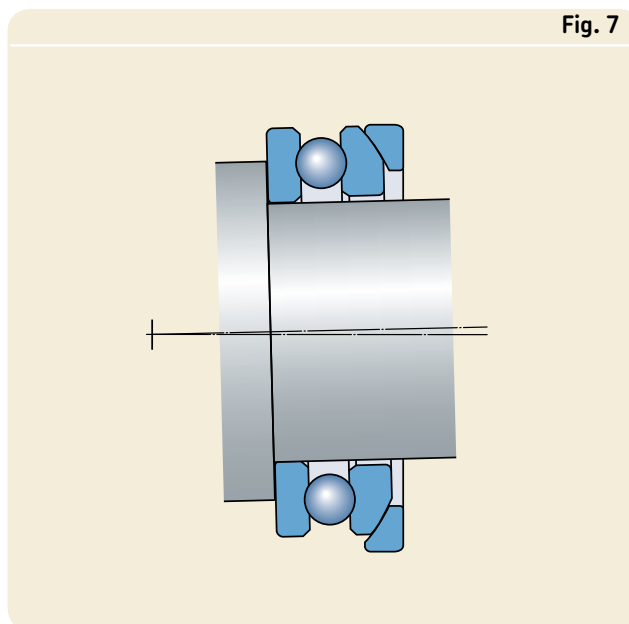

between the support surfaces in the housing and on the shaft (→ **fig. 7**).

Cages

Depending on the bearing series and size, SKF thrust ball bearings are fitted as standard with one of the following cages (→ **fig. 8**)

- a pressed steel cage, no designation suffix (**a** and **b**)
- a one-piece machined brass cage, designation suffix M (**c**)
- a one-piece machined steel cage, designation suffix F (**d**)
- a two-piece machined brass cage, designation suffix M (**e**).

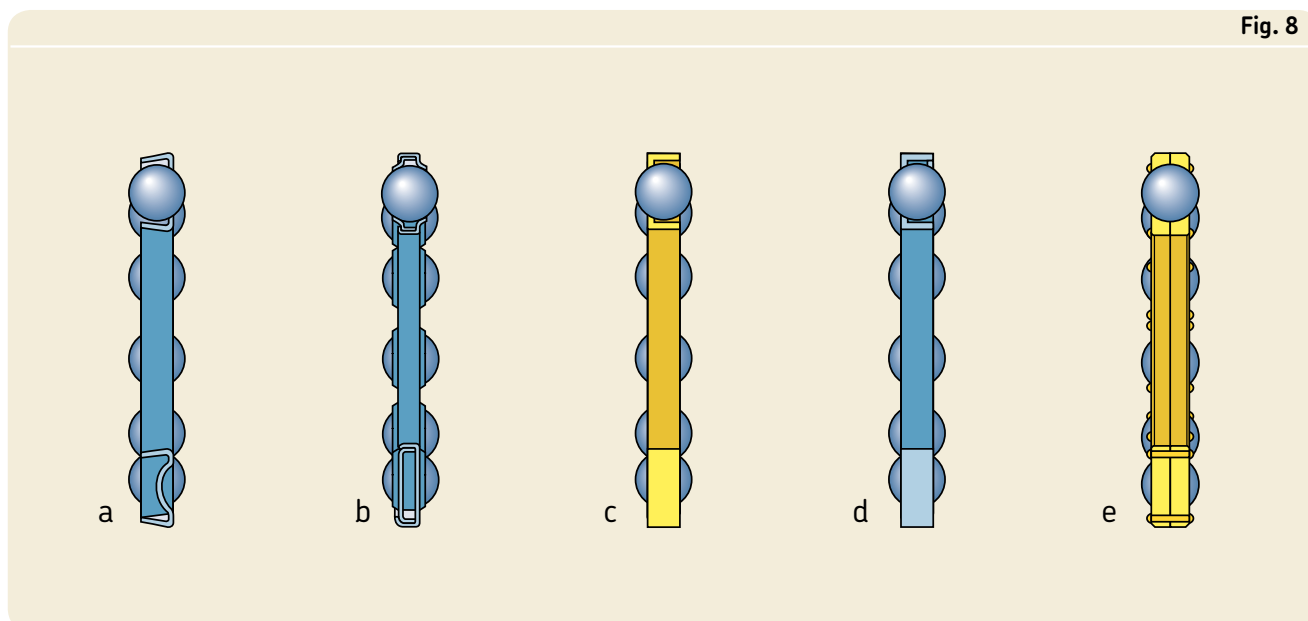

Minimum load

In order to provide satisfactory operation, thrust ball bearings, like all ball and roller bearings, must always be subjected to a given minimum load, particularly if they are to operate at high speeds or are subjected to high accelerations or rapid changes in the direction of load. Under such conditions, the inertia forces of the balls and cage(s), and the friction in the lubricant, can have a detrimental influence on the rolling conditions in the bearing arrangement and may cause damaging sliding movements to occur between the balls and raceways.

The requisite minimum axial load to be applied to thrust ball bearings can be estimated using

$$F_{am} = A \left(\frac{n}{1\,000} \right)^2$$

where

F_{am} = minimum axial load, kN

A = minimum load factor (→ product tables)

n = rotational speed, r/min

When starting up at low temperatures or when the lubricant is highly viscous, even greater minimum loads may be required. The weight of the components supported by the bearing, particularly when the shaft is vertical, together with external forces, generally exceeds the requisite minimum load. If this is not the case, the thrust ball bearing must be preloaded, e.g. by springs.

Equivalent dynamic bearing load

$$P = F_a$$

Equivalent static bearing load

$$P_0 = F_a$$

Supplementary designations

The designation suffixes used to identify certain features of SKF thrust ball bearings are explained in the following.

- F** Machined steel cage, ball centred
- JR** Cage comprising two flat pressed steel washers, ball centred
- M** Machined brass cage, ball centred
- P5** Increased dimensional and running accuracy to ISO tolerance class 5
- P6** Increased dimensional and running accuracy to ISO tolerance class 6
- TN9** Injection moulded cage of glass fibre reinforced polyamide 6,6, ball centred

Single direction thrust ball bearings
d 3 – 30 mm

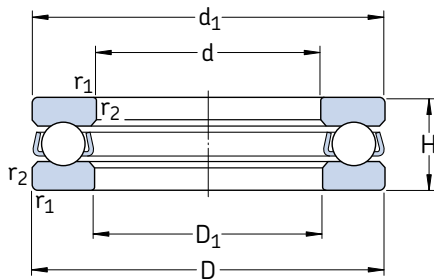

Principal dimensions			Basic load ratings		Fatigue load limit P_u	Minimum load factor A	Speed ratings		Mass	Designation
d	D	H	dynamic C	static C_0			Refer-ence speed	Limiting speed		
mm			kN		kN	–	r/min		kg	–
3	8	3,5	0,806	0,72	0,027	0,000003	26 000	36 000	0,0009	BA 3
4	10	4	0,761	0,72	0,027	0,000003	22 000	30 000	0,0015	BA 4
5	12	4	0,852	0,965	0,036	0,000005	20 000	28 000	0,0021	BA 5
6	14	5	1,78	1,92	0,071	0,000019	17 000	24 000	0,0035	BA 6
7	17	6	2,51	2,9	0,108	0,000044	14 000	19 000	0,0065	BA 7
8	19	7	3,19	3,8	0,143	0,000075	12 000	17 000	0,0091	BA 8
9	20	7	3,12	3,8	0,143	0,000075	12 000	16 000	0,010	BA 9
10	24	9	9,95	15,3	0,56	0,0012	9 500	13 000	0,020	51100
	26	11	12,7	18,6	0,70	0,0018	8 000	11 000	0,030	51200
12	26	9	10,4	16,6	0,62	0,0014	9 000	13 000	0,022	51101
	28	11	13,3	20,8	0,77	0,0022	8 000	11 000	0,034	51201
15	28	9	10,6	18,3	0,67	0,0017	8 500	12 000	0,023	51102
	32	12	16,5	27	1	0,0038	7 000	10 000	0,046	51202
17	30	9	11,4	21,2	0,78	0,0023	8 500	12 000	0,025	51103
	35	12	17,2	30	1,1	0,0047	6 700	9 500	0,053	51203
20	35	10	15,1	29	1,08	0,0044	7 500	10 000	0,037	51104
	40	14	22,5	40,5	1,53	0,0085	6 000	8 000	0,083	51204
25	42	11	18,2	39	1,43	0,0079	6 300	9 000	0,056	51105
	47	15	27,6	55	2,04	0,015	5 300	7 500	0,11	51205
	52	18	34,5	60	2,24	0,018	4 500	6 300	0,17	51305
	60	24	55,3	96,5	3,6	0,048	3 600	5 000	0,34	51405
30	47	11	19	43	1,6	0,0096	6 000	8 500	0,063	51106
	52	16	25,5	51	1,9	0,013	4 800	6 700	0,13	51206
	60	21	37,7	71	2,65	0,026	3 800	5 300	0,26	51306
	70	28	72,8	137	5,1	0,097	3 000	4 300	0,52	51406

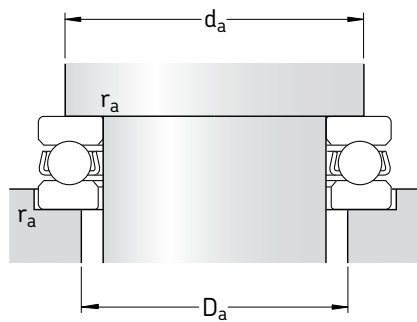

Dimensions

Abutment and fillet dimensions

d	d_1 ~	D_1 ~	$r_{1,2}$ min	d_a min	D_a max	r_a max
mm			mm			
3	7,8	3,2	0,15	5,8	5	0,15
4	9,8	4,2	0,15	7,5	6,5	0,15
5	11,8	5,2	0,15	8	9	0,15
6	13,8	6,2	0,2	11	9,5	0,2
7	16,8	7,2	0,2	12,5	11	0,2
8	18,8	8,2	0,3	14,5	12,5	0,3
9	19,8	9,2	0,3	15,5	13,5	0,3
10	24	11	0,3	19	15	0,3
	26	12	0,6	20	16	0,6
12	26	13	0,3	21	17	0,3
	28	14	0,6	22	18	0,6
15	28	16	0,3	23	20	0,3
	32	17	0,6	25	22	0,6
17	30	18	0,3	25	22	0,3
	35	19	0,6	28	24	0,6
20	35	21	0,3	29	26	0,3
	40	22	0,6	32	28	0,6
25	42	26	0,6	35	32	0,6
	47	27	0,6	38	34	0,6
	52	27	1	41	36	1
	60	27	1	46	39	1
30	47	32	0,6	40	37	0,6
	52	32	0,6	43	39	0,6
	60	32	1	48	42	1
	70	32	1	54	46	1

Single direction thrust ball bearings
d 35 – 70 mm

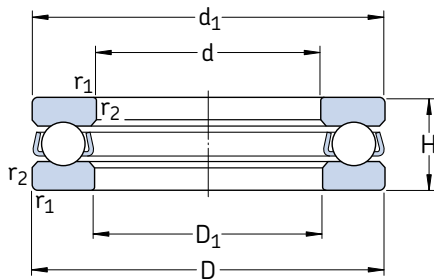

Principal dimensions			Basic load ratings		Fatigue load limit P_u	Minimum load factor A	Speed ratings		Mass	Designation
d	D	H	dynamic C	static C_0			Refer- ence speed	Limiting speed		
mm			kN		kN	–	r/min	kg	–	
35	52	12	19,9	51	1,86	0,013	5 600	7 500	0,080	51107
	62	18	35,1	73,5	2,7	0,028	4 000	5 600	0,22	51207
	68	24	49,4	96,5	3,55	0,048	3 200	4 500	0,39	51307
	80	32	87,1	170	6,2	0,15	2 600	3 800	0,79	51407
40	60	13	26	63	2,32	0,02	5 000	7 000	0,12	51108
	68	19	46,8	106	4	0,058	3 800	5 300	0,28	51208
	78	26	61,8	122	4,5	0,077	3 000	4 300	0,53	51308
	90	36	112	224	8,3	0,26	2 400	3 400	1,10	51408
45	65	14	26,5	69,5	2,55	0,025	4 500	6 300	0,14	51109
	73	20	39	86,5	3,2	0,038	3 600	5 000	0,30	51209
	85	28	76,1	153	5,6	0,12	2 800	4 000	0,66	51309
	100	39	130	265	9,8	0,37	2 200	3 000	1,40	51409
50	70	14	27	75	2,8	0,029	4 300	6 300	0,16	51110
	78	22	49,4	116	4,3	0,069	3 400	4 500	0,37	51210
	95	31	88,4	190	6,95	0,19	2 600	3 600	0,94	51310
	110	43	159	340	12,5	0,60	2 000	2 800	2,00	51410
55	78	16	30,7	85	3,1	0,039	3 800	5 300	0,23	51111
	90	25	61,8	146	5,4	0,11	2 800	4 000	0,59	51211
	105	35	104	224	8,3	0,26	2 200	3 200	1,30	51311
	120	48	178	390	14,3	0,79	1 800	2 400	2,55	51411
60	85	17	41,6	122	4,55	0,077	3 600	5 000	0,20	51112
	95	26	62,4	150	5,6	0,12	2 800	3 800	0,65	51212
	110	35	101	224	8,3	0,26	2 200	3 000	1,35	51312
	130	51	199	430	16	0,96	1 600	2 200	3,10	51412 M
65	90	18	37,7	108	4	0,06	3 400	4 800	0,33	51113
	100	27	63,7	163	6	0,14	2 600	3 600	0,78	51213
	115	36	106	240	8,8	0,30	2 000	3 000	1,50	51313
	140	56	216	490	18	1,2	1 500	2 200	4,00	51413 M
70	95	18	40,3	120	4,4	0,074	3 400	4 500	0,35	51114
	105	27	65	173	6,4	0,16	2 600	3 600	0,79	51214
	125	40	135	320	11,8	0,53	1 900	2 600	2,00	51314
	150	60	234	550	19,3	1,6	1 400	2 000	5,00	51414 M

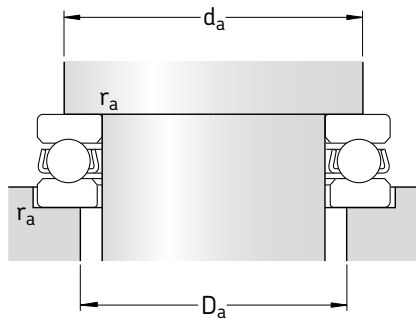

Dimensions				Abutment and fillet dimensions		
d	d ₁ ~	D ₁ ~	r _{1,2} min	d _a min	D _a max	r _a max
mm				mm		
35	52	37	0,6	45	42	0,6
	62	37	1	51	46	1
	68	37	1	55	48	1
	80	37	1,1	62	53	1
40	60	42	0,6	52	48	0,6
	68	42	1	57	51	1
	78	42	1	63	55	1
	90	42	1,1	70	60	1
45	65	47	0,6	57	53	0,6
	73	47	1	62	56	1
	85	47	1	69	61	1
	100	47	1,1	78	67	1
50	70	52	0,6	62	58	0,6
	78	52	1	67	61	1
	95	52	1,1	77	68	1
	110	52	1,5	86	74	1,5
55	78	57	0,6	69	64	0,6
	90	57	1	76	69	1
	105	57	1,1	85	75	1
	120	57	1,5	94	81	1,5
60	85	62	1	75	70	1
	95	62	1	81	74	1
	110	62	1,1	90	80	1
	130	62	1,5	102	88	1,5
65	90	67	1	80	75	1
	100	67	1	86	79	1
	115	67	1,1	95	85	1
	140	68	2	110	95	2
70	95	72	1	85	80	1
	105	72	1	91	84	1
	125	72	1,1	103	92	1
	150	73	2	118	102	2

Single direction thrust ball bearings
d 75 – 130 mm

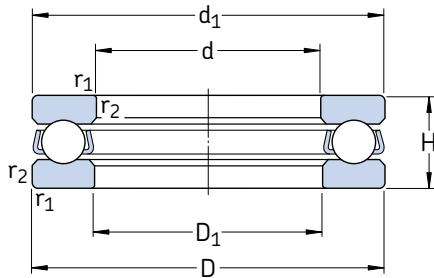

Principal dimensions			Basic load ratings		Fatigue load limit P_u	Minimum load factor A	Speed ratings		Mass	Designation
d	D	H	dynamic C	static C_0			Refer- ence speed	Limiting speed		
mm			kN		kN	–	r/min		kg	–
75	100	19	44,2	146	5,5	0,11	3 200	4 300	0,40	51115
	110	27	67,6	183	6,8	0,17	2 400	3 400	0,83	51215
	135	44	163	390	14	0,79	1 700	2 400	2,60	51315
	160	65	251	610	20,8	1,9	1 300	1 800	6,75	51415 M
80	105	19	44,9	153	5,7	0,12	3 000	4 300	0,42	51116
	115	28	76,1	208	7,65	0,22	2 400	3 400	0,91	51216
	140	44	159	390	13,7	0,79	1 700	2 400	2,70	51316
	170	68	270	670	22,4	2,3	1 200	1 700	7,95	51416 M
85	110	19	46,2	163	6	0,14	3 000	4 300	0,44	51117
	125	31	97,5	275	9,8	0,39	2 200	3 000	1,20	51217
	150	49	190	465	16	1,1	1 600	2 200	3,55	51317
	180	72	286	750	24	2,9	1 200	1 600	9,45	51417 M
90	120	22	59,2	208	7,5	0,22	2 600	3 800	0,67	51118
	135	35	119	325	11,4	0,55	2 000	2 800	1,70	51218
	155	50	195	500	16,6	1,3	1 500	2 200	3,80	51318
	190	77	307	815	25,5	3,5	1 100	1 500	11,0	51418 M
100	135	25	85,2	290	10	0,44	2 400	3 200	0,97	51120
	150	38	124	345	11,4	0,62	1 800	2 400	2,20	51220
	170	55	229	610	19,6	1,9	1 400	1 900	4,95	51320
	210	85	371	1 060	31,5	5,8	950	1 400	15,0	51420 M
110	145	25	87,1	315	10,2	0,52	2 200	3 200	1,05	51122
	160	38	130	390	12,5	0,79	1 700	2 400	2,40	51222
	190	63	276	780	24	3,2	1 200	1 700	7,85	51322 M
	230	95	410	1 220	34,5	7,7	900	1 300	20,0	51422 M
120	155	25	88,4	335	10,6	0,58	2 200	3 000	1,15	51124
	170	39	140	440	13,4	1	1 600	2 200	2,65	51224
	210	70	325	980	28,5	5	1 100	1 500	11,0	51324 M
	250	102	520	1 730	45	16	800	1 100	29,5	51424 M
130	170	30	111	425	12,9	0,94	1 900	2 600	1,85	51126
	190	45	186	585	17	1,8	1 400	2 000	4,00	51226
	225	75	358	1 140	32	6,8	1 000	2 400	13,0	51326 M
	270	110	520	1 730	45	16	750	1 000	32,0	51426 M

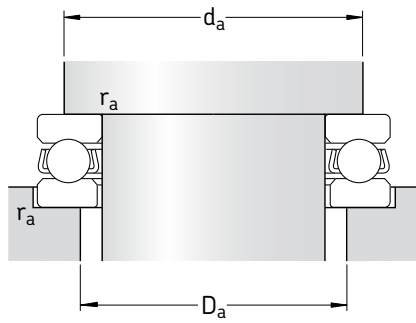

Dimensions

Abutment and fillet dimensions

d	d_1 ~	D_1 ~	$r_{1,2}$ min	d_a min	D_a max	r_a max
mm			mm			
75	100	77	1	90	85	1
	110	77	1	96	89	1
	135	77	1,5	111	99	1,5
	160	78	2	126	109	2
80	105	82	1	95	90	1
	115	82	1	101	94	1
	140	82	1,5	116	104	1,5
	170	83	2,1	133	117	2
85	110	87	1	100	95	1
	125	88	1	109	101	1
	150	88	1,5	124	111	1,5
	177	88	2,1	141	124	2
90	120	92	1	108	102	1
	135	93	1,1	117	108	1
	155	93	1,5	129	116	1,5
	187	93	2,1	149	131	2
100	135	102	1	121	114	1
	150	103	1,1	130	120	1
	170	103	1,5	142	128	1,5
	205	103	3	165	145	2,5
110	145	112	1	131	124	1
	160	113	1,1	140	130	1
	187	113	2	158	142	2
	225	113	3	181	159	2,5
120	155	122	1	141	134	1
	170	123	1,1	150	140	1
	205	123	2,1	173	157	2
	245	123	4	197	173	3
130	170	132	1	154	146	1
	187	133	1,5	166	154	1,5
	220	134	2,1	186	169	2
	265	134	4	213	187	3

Single direction thrust ball bearings
d 140 – 280 mm

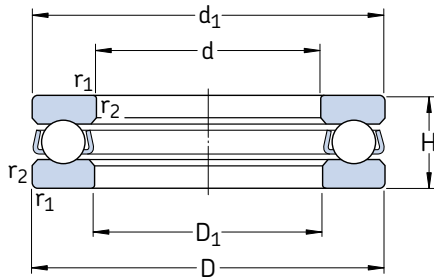

Principal dimensions			Basic load ratings		Fatigue load limit P_u	Minimum load factor A	Speed ratings		Mass	Designation
d	D	H	dynamic C	static C_0			Refer- ence speed	Limiting speed		
mm			kN		kN	–	r/min		kg	–
140	180	31	111	440	12,9	1	1 800	2 600	2,05	51128
	200	46	190	620	17,6	2	1 400	1 900	4,35	51228
	240	80	397	1 320	35,5	9,1	950	1 300	15,5	51328 M
	280	112	520	1 730	44	16	700	1 000	34,5	51428 M
150	190	31	111	440	12,5	1	1 700	2 400	2,20	51130 M
	215	50	238	800	22	3,3	1 300	1 800	6,10	51230 M
	250	80	410	1 400	36,5	10	900	1 300	16,5	51330 M
	300	120	559	1 960	48	20	670	950	42,5	51430 M
160	200	31	112	465	12,9	1,1	1 700	2 400	2,35	51132 M
	225	51	242	850	22,8	3,8	1 200	1 700	6,55	51232 M
	270	87	449	1 660	41,5	14	850	1 200	21,0	51332 M
170	215	34	133	540	14,3	1,5	1 600	2 200	3,30	51134 M
	240	55	286	1 020	26	5,4	1 100	1 800	8,15	51234 M
	280	87	468	1 760	43	16	800	1 100	22,0	51334 M
180	225	34	135	570	15	1,7	1 500	2 200	3,50	51136 M
	250	56	296	1 080	27,5	6,1	1 100	1 500	8,60	51236 M
	300	95	520	2 000	47,5	21	750	1 100	28,5	51336 M
190	240	37	172	710	18	2,6	1 400	2 000	4,05	51138 M
	270	62	332	1 270	31	8,4	1 000	1 400	12,0	51238 M
	320	105	592	2 400	56	30	700	950	36,5	51338 M
200	250	37	168	710	17,6	2,6	1 400	1 900	4,25	51140 M
	280	62	338	1 320	31,5	9,1	1 000	1 400	12,0	51240 M
	340	110	624	2 600	58,5	35	630	900	44,5	51340 M
220	270	37	178	800	19	3,3	1 300	1 900	4,60	51144 M
	300	63	351	1 460	33,5	11	950	1 300	13,0	51244 M
240	300	45	234	1 040	23,6	5,6	1 100	1 600	7,55	51148 M
	340	78	462	2 000	44	21	800	1 100	23,0	51248 M
260	320	45	238	1 100	24	6,3	1 100	1 500	8,10	51152 M
	360	79	475	2 160	45,5	24	750	1 100	25,0	51252 M
280	350	53	319	1 460	30,5	11	950	1 300	12,0	51156 M
	380	80	494	2 320	47,5	28	750	1 000	26,5	51256 M

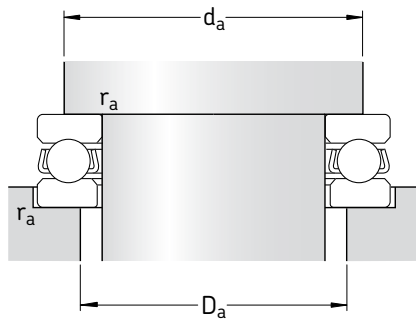

Dimensions
Abutment and fillet dimensions

d	d ₁ ~	D ₁ ~	r _{1,2} min	d _a min	D _a max	r _a max
mm			mm			
140	178	142	1	164	156	1
	197	143	1,5	176	164	1,5
	235	144	2,1	199	181	2
	275	144	4	223	197	3
150	188	152	1	174	166	1
	212	153	1,5	189	176	1,5
	245	154	2,1	209	191	2
	295	154	4	239	211	3
160	198	162	1	184	176	1
	222	163	1,5	199	186	1,5
	265	164	3	225	205	2,5
170	213	172	1,1	197	188	1
	237	173	1,5	212	198	1,5
	275	174	3	235	215	2,5
180	222	183	1,1	207	198	1
	245	183	1,5	222	208	1,5
	295	184	3	251	229	2,5
190	237	193	1,1	220	210	1
	265	194	2	238	222	2
	315	195	4	267	243	3
200	247	203	1,1	230	220	1
	275	204	2	248	232	2
	335	205	4	283	257	3
220	267	223	1,1	250	240	1
	295	224	2	268	252	2
240	297	243	1,5	276	264	1,5
	335	244	2,1	299	281	2
260	317	263	1,5	296	284	1,5
	355	264	2,1	319	301	2
280	347	283	1,5	322	308	1,5
	375	284	2,1	339	321	2

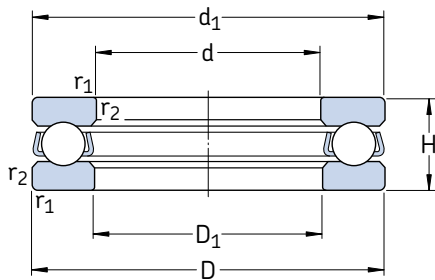
Single direction thrust ball bearings
d 300 – 670 mm

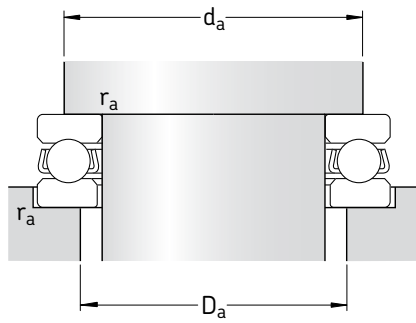

Principal dimensions			Basic load ratings		Fatigue load limit P_u	Minimum load factor A	Speed ratings		Mass	Designation
d	D	H	dynamic C	static C_0			Refer-ence speed	Limiting speed		
mm			kN		kN	–	r/min		kg	–
300	380	62	364	1 760	35,5	16	850	1 200	17,5	51160 M
	420	95	605	3 000	58,5	47	630	850	42,0	51260 M
320	400	63	371	1 860	36,5	18	800	1 100	19,0	51164 M
	440	95	572	3 000	56	47	600	850	45,5	51264 F
340	420	64	377	1 960	37,5	20	800	1 100	20,5	51168 M
	460	96	605	3 200	58,5	53	600	800	48,5	51268 F
360	440	65	390	2 080	38	22	750	1 100	22,0	51172 F
	500	110	741	4 150	73,5	90	530	750	70,0	51272 F
380	460	65	397	2 200	40	25	750	1 000	23,0	51176 F
	520	112	728	4 150	72	90	500	700	73,0	51276 F
400	480	65	403	2 280	40,5	27	700	1 000	24,0	51180 F
420	500	65	410	2 400	41,5	30	700	1 000	25,5	51184 F
440	540	80	527	3 250	55	55	600	850	42,0	51188 F
460	560	80	527	3 250	54	55	600	800	43,5	51192 F
480	580	80	540	3 550	56	66	560	800	45,5	51196 F
500	600	80	553	3 600	57	67	560	800	47,0	511/500 F
530	640	85	650	4 400	68	100	530	750	58,5	511/530 F
560	670	85	663	4 650	69,5	110	500	700	61,0	511/560 F
600	710	85	663	4 800	69,5	120	500	700	65,0	511/600 F
630	750	95	728	5 400	76,5	150	450	630	84,0	511/630 F
670	800	105	852	6 700	91,5	230	400	560	105	511/670 F



Dimensions

Abutment and fillet dimensions

d	d_1 ~	D_1 ~	$r_{1,2}$ min	d_a min	D_a max	r_a max
mm				mm		
300	376	304	2	348	332	2
	415	304	3	371	349	2,5
320	396	324	2	368	352	2
	435	325	3	391	369	2,5
340	416	344	2	388	372	2
	455	345	3	411	389	2,5
360	436	364	2	408	392	2
	495	365	4	443	417	3
380	456	384	2	428	412	2
	515	385	4	463	437	3
400	476	404	2	448	432	2
420	496	424	2	468	452	2
440	536	444	2,1	499	481	2
460	556	464	2,1	519	501	2
480	576	484	2,1	539	521	2
500	596	504	2,1	559	541	2
530	636	534	3	595	575	2,5
560	666	564	3	625	606	2,5
600	706	604	3	665	645	2,5
630	746	634	3	701	679	2,5
670	795	675	4	747	723	3

**Single direction thrust ball bearings
with sphered housing washer**
d **12 – 70** mm

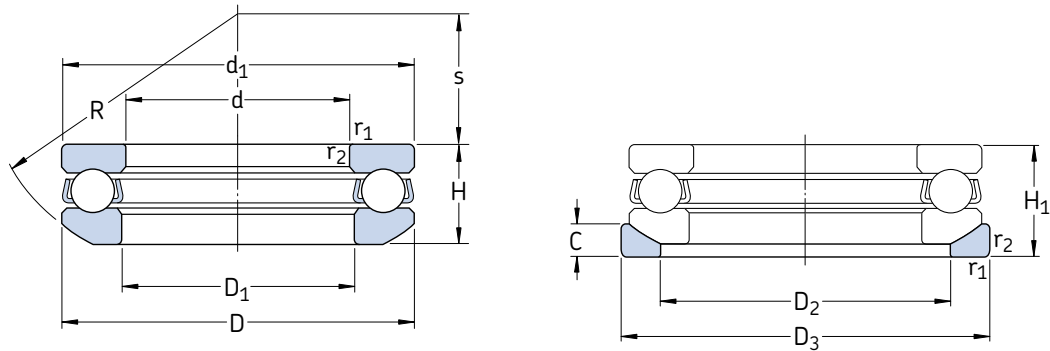

Principal dimensions			Basic load ratings		Fatigue load limit P_u	Minimum load factor A	Speed ratings		Mass Bearing + washer	Designations	
d	D	H_1	C	C_0			Refer- ence speed	Limiting speed		Bearing	Seating washer
mm			kN		kN	–	r/min		kg	–	
12	28	13	13,3	20,8	0,77	0,0022	8 000	11 000	0,045	53201	U 201
15	32	15	16,5	27	1	0,0038	7 000	10 000	0,063	53202	U 202
17	35	15	17,2	30	1,1	0,0047	6 700	9 500	0,071	53203	U 203
20	40	17	22,5	40,5	1,53	0,0085	6 000	8 000	0,10	53204	U 204
25	47	19	27,6	55	2,04	0,015	5 300	7 500	0,15	53205	U 205
30	52	20	25,5	51	1,9	0,013	4 800	6 700	0,18	53206	U 206
	60	25	37,7	71	2,65	0,026	3 800	5 300	0,33	53306	U 306
35	62	22	35,1	73,5	2,7	0,028	4 000	5 600	0,28	53207	U 207
	68	28	49,4	96,5	3,55	0,048	3 200	4 500	0,46	53307	U 307
40	68	23	46,8	106	4	0,058	3 800	5 300	0,35	53208	U 208
	78	31	61,8	122	4,5	0,077	3 000	4 300	0,67	53308	U 308
	90	42	112	224	8,3	0,26	2 400	3 400	1,35	53408	U 408
45	73	24	39	86,5	3,2	0,038	3 600	5 000	0,39	53209	U 209
	85	33	76,1	153	5,6	0,12	2 800	4 000	0,83	53309	U 309
50	78	26	49,4	116	4,3	0,069	3 400	4 500	0,47	53210	U 210
	95	37	88,4	190	6,95	0,19	2 600	3 600	1,20	53310	U 310
	110	50	159	340	12,5	0,60	2 000	2 800	2,31	53410	U 410
55	90	30	61,8	146	5,4	0,11	2 800	4 000	0,75	53211	U 211
	105	42	104	224	8,3	0,26	2 200	3 200	1,68	53311	U 311
	120	55	178	390	14,3	0,79	1 800	2 400	3,08	53411	U 411
60	95	31	62,4	150	5,6	0,12	2 800	3 800	0,82	53212	U 212
	110	42	101	224	8,3	0,26	2 200	3 000	1,71	53312	U 312
	130	58	199	430	16	0,96	1 600	2 200	3,80	53412 M	U 412
65	100	32	63,7	163	6	0,14	2 600	3 600	0,91	53213	U 213
	115	43	106	240	8,8	0,30	2 000	3 000	1,89	53313	U 313
70	105	32	65	173	6,4	0,16	2 600	3 600	0,97	53214	U 214
	125	48	135	320	11,8	0,53	1 900	2 600	2,50	53314	U 314
	150	69	234	550	19,3	1,6	1 400	2 000	6,50	53414 M	U 414

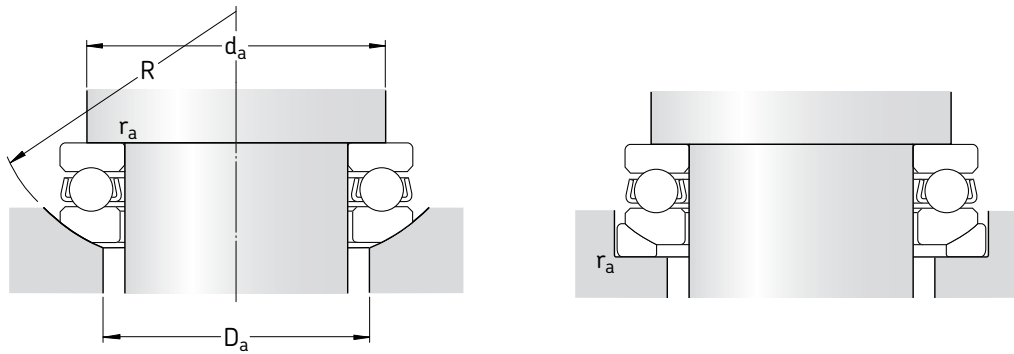

Dimensions

Abutment and fillet dimensions

d	d ₁	D ₁	D ₂	D ₃	H	C	R	s	r _{1,2} min	d _a max	D _a max	r _a max
mm										mm		
12	28	14	20	30	11,4	3,5	25	11,5	0,6	22	20	0,6
15	32	17	24	35	13,3	4	28	12	0,6	25	24	0,6
17	35	19	26	38	13,2	4	32	16	0,6	28	26	0,6
20	40	22	30	42	14,73	5	36	18	0,6	32	30	0,6
25	47	27	36	50	16,72	5,5	40	19	0,6	38	36	0,6
30	52	32	42	55	17,8	5,5	45	22	0,6	43	42	0,6
	60	32	45	62	22,6	7	50	22	1	48	45	1
35	62	37	48	65	19,87	7	50	24	1	51	48	1
	68	37	52	72	25,6	7,5	56	24	1	55	52	1
40	68	42	55	72	20,3	7	56	28,5	1	57	55	1
	78	42	60	82	28,5	8,5	64	28	1	63	60	1
	90	42	65	95	38,2	12	72	26	1,1	70	65	1
45	73	47	60	78	21,3	7,5	56	26	1	62	60	1
	85	47	65	90	30,13	10	64	25	1	69	65	1
50	78	52	62	82	23,49	7,5	64	32,5	1	67	62	1
	95	52	72	100	34,3	11	72	28	1,1	77	72	1
	110	52	80	115	45,6	14	90	35	1,5	86	80	1,5
55	90	57	72	95	27,35	9	72	35	1	76	72	1
	105	57	80	110	39,3	11,5	80	30	1,1	85	80	1
	120	57	88	125	50,5	15,5	90	28	1,5	94	88	1,5
60	95	62	78	100	28,02	9	72	32,5	1	81	78	1
	110	62	85	115	38,3	11,5	90	41	1,1	90	85	1
	130	62	95	135	54	16	100	34	1,5	102	95	1,5
65	100	67	82	105	28,7	9	80	40	1	86	82	1
	115	67	90	120	39,4	12,5	90	38,5	1,1	95	90	1
70	105	72	88	110	28,8	9	80	38	1	91	88	1
	125	72	98	130	44,2	13	100	43	1,1	103	98	1
	150	73	110	155	63,6	19,5	112	34	2	118	110	2

**Single direction thrust ball bearings
with sphered housing washer**
d **75 – 140** mm

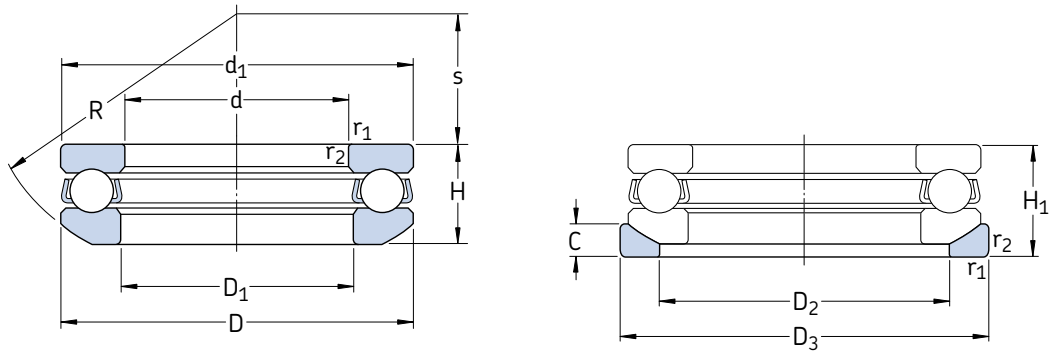

Principal dimensions			Basic load ratings dynamic static		Fatigue load limit P_u	Minimum load factor A	Speed ratings Refer- ence speed		Limiting speed	Mass Bearing + washer	Designations Bearing	Seating washer
d	D	H_1	C	C_0								
mm			kN		kN	–	r/min			kg	–	
75	110	32	67,6	183	6,8	0,17	2 400	3 400	1,00	53215	U 215	
	135	52	163	390	14	0,79	1 700	2 400	3,20	53315	U 315	
	160	75	251	610	20,8	1,9	1 300	1 800	8,10	53415 M	U 415	
80	115	33	76,1	208	7,65	0,22	2 400	3 400	1,10	53216	U 216	
	140	52	159	390	13,7	0,79	1 700	2 400	3,30	53316	U 316	
85	125	37	97,5	275	9,8	0,39	2 200	3 000	1,50	53217	U 217	
	150	58	190	465	16	1,1	1 600	2 200	4,35	53317	U 317	
90	135	42	119	325	11,4	0,55	2 000	2 800	2,10	53218	U 218	
	155	59	195	500	16,6	1,3	1 500	2 200	4,70	53318	U 318	
	190	88	307	815	25,5	3,5	1 100	1 500	13,0	53418 M	U 418	
100	150	45	124	345	11,4	0,62	1 800	2 400	2,70	53220	U 220	
	170	64	229	610	19,6	1,9	1 400	1 900	5,95	53320	U 320	
	210	98	371	1 060	31,5	5,8	950	1 400	18,0	53420 M	U 420	
110	160	45	130	390	12,5	0,79	1 700	2 400	2,91	53222	U 222	
	190	72	276	780	24	3,2	1 200	1 700	9,10	53322 M	U 322	
120	170	46	140	440	13,4	1	1 600	2 200	3,20	53224	U 224	
	210	80	325	980	28,5	5	1 100	1 500	12,5	53324 M	U 324	
130	190	53	186	585	17	1,8	1 400	2 000	4,85	53226	U 226	
140	200	55	190	620	17,6	2	1 400	1 900	5,45	53228	U 228	

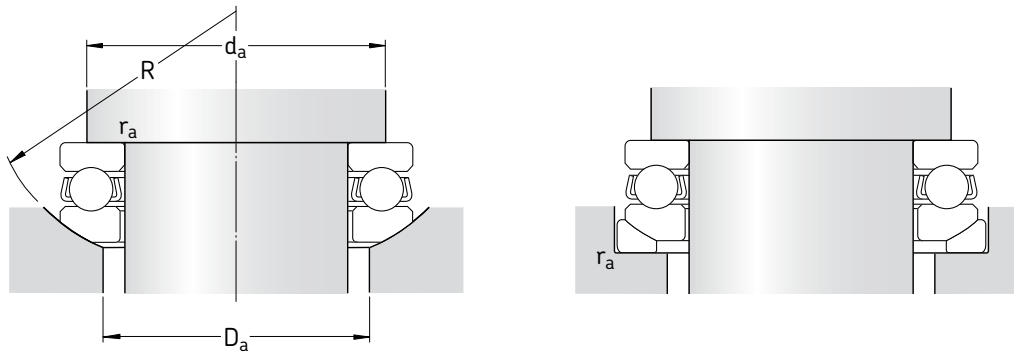

Dimensions

Abutment and fillet dimensions

d	d ₁	D ₁	D ₂	D ₃	H	C	R	s	r _{1,2} min	d _a max	D _a max	r _a max
mm										mm		
75	110	77	92	115	28,3	9,5	90	49	1	96	92	1
	135	77	105	140	48,1	15	100	37	1,5	111	105	1,5
	160	78	115	165	69	21	125	42	2	126	115	2
80	115	82	98	120	29,5	10	90	46	1	101	98	1
	140	82	110	145	47,6	15	112	50	1,5	116	110	1,5
85	125	88	105	130	33,1	11	100	52	1	109	105	1
	150	88	115	155	53,1	17,5	112	43	1,5	124	115	1,5
90	135	93	110	140	38,5	13,5	100	45	1,1	117	110	1
	155	93	120	160	54,6	18	112	40	1,5	129	120	1,5
	187	93	140	195	81,2	25,5	140	40	2,1	133	125	2
100	150	103	125	155	40,9	14	112	52	1,1	130	125	1
	170	103	135	175	59,2	18	125	46	1,5	142	135	1,5
	205	103	155	220	90	27	160	50	3	165	155	2,5
110	160	113	135	165	40,2	14	125	65	1,1	140	135	1
	187	113	150	195	67,2	20,5	140	51	2	158	150	2
120	170	123	145	175	40,8	15	125	61	1,1	150	145	1
	205	123	165	220	74,1	22	160	63	2,1	173	165	2
130	187	133	160	195	47,9	17	140	67	1,5	166	160	1,5
140	197	143	170	210	48,6	17	160	87	1,5	176	170	1,5

Double direction thrust ball bearings d 10 – 55 mm

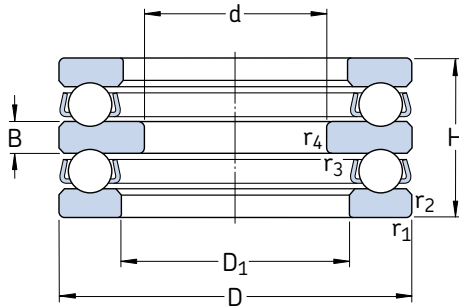

Principal dimensions			Basic load ratings		Fatigue load limit P_u	Minimum load factor A	Speed ratings		Mass	Designation
d	D	H	dynamic C	static C_0			Refer- ence speed	Limiting speed		
mm			kN		kN	–	r/min	kg	–	
10	32	22	16,5	27	1	0,0038	7 000	10 000	0,081	52202
15	40	26	22,5	40,5	1,53	0,0085	6 000	8 000	0,15	52204
20	47	28	27,6	55	2,04	0,015	5 300	7 500	0,22	52205
	52	34	34,5	60	2,24	0,018	4 500	6 300	0,33	52305
	70	52	72,8	137	5,1	0,097	3 600	5 000	1,00	52406
25	52	29	25,5	51	1,9	0,013	4 800	6 700	0,25	52206
	60	38	37,7	71	2,65	0,026	3 800	5 300	0,47	52306
	80	59	87,1	170	6,2	0,15	3 000	4 300	1,45	52407
30	62	34	35,1	73,5	2,7	0,028	4 000	5 600	0,41	52207
	68	36	46,8	106	4	0,058	3 800	5 300	0,55	52208
	68	44	49,4	96,5	3,55	0,048	3 200	4 500	0,68	52307
	78	49	61,8	122	4,5	0,077	3 000	4 300	1,05	52308
	90	65	112	224	8,3	0,26	2 400	3 400	2,05	52408
35	73	37	39	86,5	3,2	0,038	3 600	5 000	0,60	52209
	85	52	76,1	153	5,6	0,12	2 800	4 000	1,25	52309
	100	72	130	265	9,8	0,37	2 200	3 000	2,70	52409
40	78	39	49,4	116	4,3	0,069	3 400	4 500	0,71	52210
	95	58	88,4	190	6,95	0,19	2 600	3 600	1,75	52310
45	90	45	61,8	146	5,4	0,11	2 800	4 000	1,10	52211
	105	64	104	224	8,3	0,26	2 200	3 200	2,40	52311
	120	87	178	390	14,3	0,79	1 800	2 400	4,70	52411
50	95	46	62,4	150	5,6	0,12	2 200	3 000	1,20	52212
	110	64	101	224	8,3	0,26	1 600	2 200	2,55	52312
	130	93	199	430	16	0,96	1 600	2 200	6,35	52412 M
55	100	47	63,7	163	6	0,14	2 600	3 600	1,35	52213
	105	47	65	173	6,4	0,16	2 600	3 600	1,50	52214
	115	65	106	240	8,8	0,30	2 000	3 000	2,75	52313
	125	72	135	320	11,8	0,53	1 900	2 600	3,65	52314
	150	107	234	550	19,3	1,6	1 400	2 000	9,70	52414 M

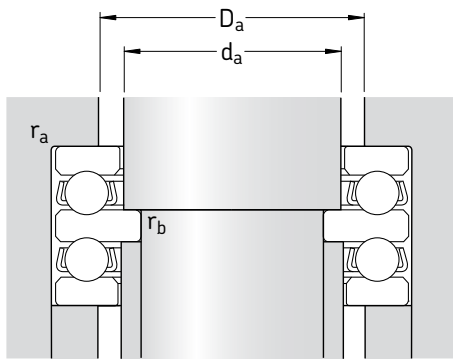

Dimensions

Abutment and fillet dimensions

d	D_1 ~	B	$r_{1,2}$ min	$r_{3,4}$ min	d_a	D_a max	r_a max	r_b max
mm					mm			
10	17	5	0,6	0,3	15	22	0,6	0,3
15	22	6	0,6	0,3	20	28	0,6	0,3
20	27	7	0,6	0,3	25	34	0,6	0,3
	27	8	1	0,3	25	36	1	0,3
	32	12	1	0,6	30	46	1	0,6
25	32	7	0,6	0,3	30	39	0,6	0,3
	32	9	1	0,3	30	42	1	0,3
	37	14	1,1	0,6	35	53	1	0,6
30	37	8	1	0,3	35	46	1	0,3
	42	9	1	0,6	40	51	1	0,6
	37	10	1	0,3	35	48	1	0,3
	42	12	1	0,6	40	55	1	0,6
	42	15	1,1	0,6	40	60	1	0,6
35	47	9	1	0,6	45	56	1	0,6
	47	12	1	0,6	45	61	1	0,6
	47	17	1,1	0,6	45	67	1	0,6
40	52	9	1	0,6	50	61	1	0,6
	52	14	1,1	0,6	50	68	1	0,6
45	57	10	1	0,6	55	69	1	0,6
	57	15	1,1	0,6	55	75	1	0,6
	57	20	1,5	0,6	55	81	1,5	0,6
50	62	10	1	0,6	60	74	1	0,6
	62	15	1,1	0,6	60	80	1	0,6
	62	21	1,5	0,6	60	88	1,5	0,6
55	67	10	1	0,6	65	79	1	0,6
	72	10	1	1	70	84	1	1
	67	15	1,1	0,6	65	85	1	0,6
	72	16	1,1	1	70	92	1	1
	73	24	2	1	70	102	2	1

Double direction thrust ball bearings
d 60 – 150 mm

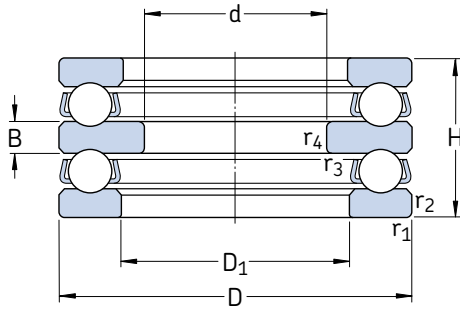

Principal dimensions			Basic load ratings		Fatigue load limit P_u	Minimum load factor A	Speed ratings		Mass	Designation
d	D	H	dynamic C	static C_0			Refer- ence speed	Limiting speed		
mm			kN		kN	–	r/min		kg	–
60	110	47	67,6	183	6,8	0,17	2 400	3 400	1,55	52215
	135	79	163	390	14	0,79	1 700	2 400	4,80	52315
65	115	48	76,1	208	7,65	0,22	2 400	3 400	1,70	52216
	140	79	159	390	13,7	0,79	1 700	2 400	4,94	52316
70	125	55	97,5	275	9,8	0,39	2 200	3 000	2,40	52217
75	135	62	119	325	11,4	0,55	2 000	2 800	3,20	52218
85	150	67	124	345	11,4	0,62	1 800	2 400	4,20	52220
	170	97	229	610	19,6	1,9	1 400	1 900	8,95	52320
95	160	67	130	390	12,5	0,79	1 700	2 400	4,65	52222
100	170	68	140	440	13,4	1	1 600	2 200	5,25	52224
110	190	80	186	585	17	1,8	1 400	2 000	8,00	52226
120	200	81	190	620	17,6	2	1 400	1 900	8,65	52228
130	215	89	238	800	22	3,3	1 300	1 800	11,5	52230 M
140	225	90	242	850	22,8	3,8	1 200	1 700	12,0	52232 M
150	240	97	286	1 020	26	5,4	1 100	1 600	15,0	52234 M
	250	98	296	1 080	27,5	6,1	1 100	1 500	16,0	52236 M

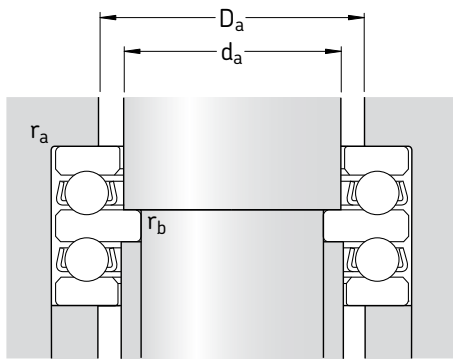

Dimensions

Abutment and fillet dimensions

d	D_1 ~	B	$r_{1,2}$ min	$r_{3,4}$ min	d_a	D_a max	r_a max	r_b max
mm					mm			
60	77	10	1	1	75	89	1	1
	77	18	1,5	1	75	99	1,5	1
65	82	10	1	1	80	94	1	1
	82	18	1,5	1	80	104	1,5	1
70	88	12	1	1	85	101	1	1
75	93	14	1,1	1	90	108	1	1
85	103	15	1,1	1	100	120	1	1
	103	21	1,5	1	100	128	1,5	1
95	113	15	1,1	1	110	130	1	1
100	123	15	1,1	1,1	120	140	1	1
110	133	18	1,5	1,1	130	154	1,5	1
120	143	18	1,5	1,1	140	164	1,5	1
130	153	20	1,5	1,1	150	176	1,5	1
140	163	20	1,5	1,1	160	186	1,5	1
	163	20	1,5	1,1	160	186	1,5	1
150	173	21	1,5	1,1	170	198	1,5	1
	183	21	1,5	2	180	208	1,5	2

**Double direction thrust ball bearings
with sphered housing washers**
d **25 – 80** mm

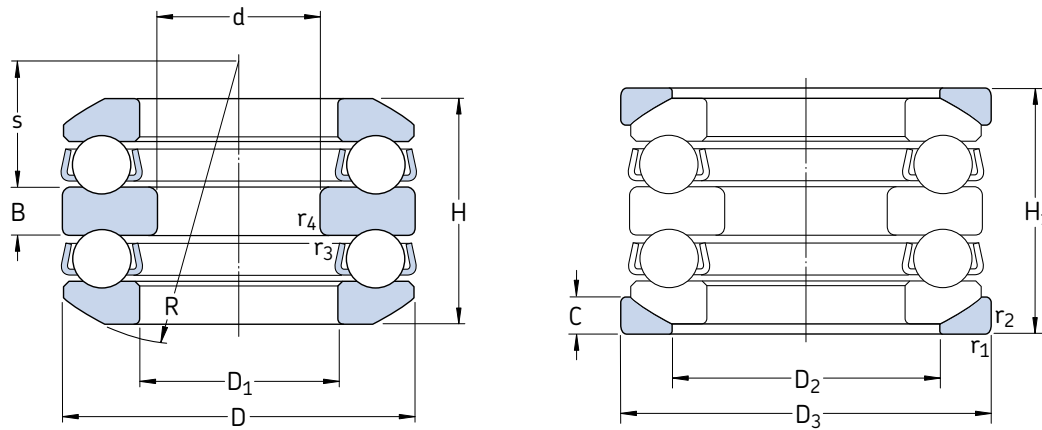

Principal dimensions			Basic load ratings		Fatigue load limit P_u	Minimum load factor A	Speed ratings		Mass Bearing + washer	Designations	
d	D	H_1	dynamic	static			Refer- ence speed	Limiting speed		Bearing	Seating washer
mm			kN		kN	–	r/min		kg	–	
25	60	46	37,7	71	2,65	0,026	3 800	5 300	0,58	54306	U 306
30	62	42	35,1	73,5	2,7	0,028	4 000	5 600	0,53	54207	U 207
	68	44	46,8	106	4	0,058	3 800	5 300	0,63	54208	U 208
	68	52	49,4	96,5	3,55	0,048	3 200	4 500	0,85	54307	U 307
	78	59	61,8	122	4,5	0,077	3 000	4 300	1,17	54308	U 308
35	73	45	39	86,5	3,2	0,038	3 600	5 000	0,78	54209	U 209
	85	62	76,1	153	5,6	0,12	2 800	4 000	1,60	54309	U 309
	100	86	130	265	9,8	0,37	2 200	3 000	3,00	54409	U 409
40	95	70	88,4	190	6,95	0,19	2 600	3 600	2,30	54310	U 310
	110	92	159	340	12,5	0,60	2 000	2 800	4,45	54410	U 410
45	90	55	61,8	146	5,4	0,11	2 800	4 000	1,30	54211	U 211
50	110	78	101	224	8,3	0,26	2 200	3 000	2,90	54312	U 312
65	140	95	159	390	13,7	0,79	1 700	2 400	0,57	54316	U 316
	170	140	270	670	22,4	2,3	1 200	1 700	1,40	54416 M	U 416
70	150	105	190	465	16	1,1	1 600	2 200	7,95	54317	U 317
80	210	176	371	1 060	31,5	5,8	950	1 400	29,0	54420 M	U 420

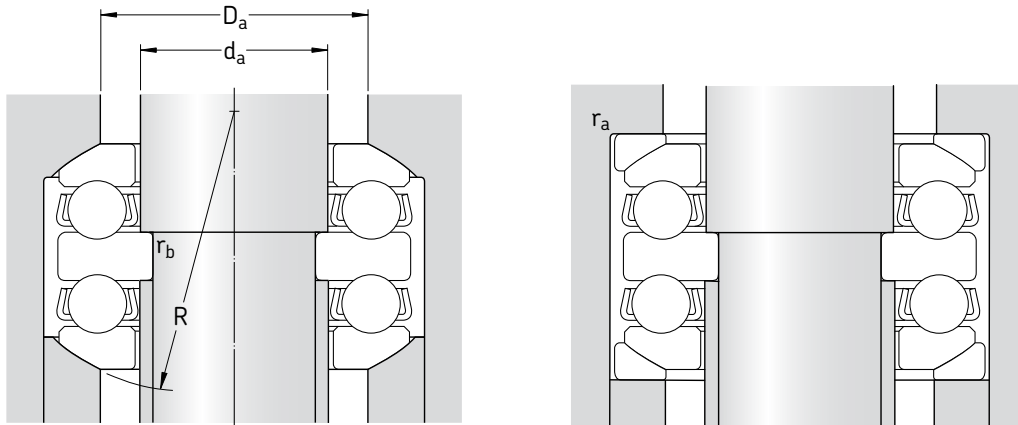

Dimensions											Abutment and fillet dimensions			
d	D ₁	D ₂	D ₃	H	B	C	R	s	r _{1,2} min	r _{3,4} min	d _a	D _a max	r _a max	r _b max
mm											mm			
25	32	45	62	41,3	9	7	50	19,5	1	0,3	30	45	1	0,3
30	37	48	65	37,73	8	7	50	21	1	0,3	35	48	1	0,3
	42	55	72	38,6	9	7	56	25	1	0,6	40	55	1	0,6
	37	52	72	47,19	10	7,5	56	21	1	0,3	35	52	1	0,3
	42	60	82	54,1	12	8,5	64	23,5	1	0,6	40	60	1	0,6
35	47	60	78	39,6	9	7,5	56	23	1	0,6	45	60	1	0,6
	47	65	90	56,2	12	10	64	21	1	0,6	45	65	1	0,6
	47	72	105	78,9	17	12,5	80	23,5	1,1	0,6	45	72	1	0,6
40	52	72	100	64,7	14	11	72	23	1,1	0,6	50	72	1	0,6
	52	80	115	83,2	18	14	90	30	1,5	0,6	50	80	1,5	0,6
45	57	72	95	49,6	10	9	72	32,5	1	0,6	55	72	1	0,6
50	62	85	115	70,7	15	11,5	90	36,5	1,1	0,6	60	85	1	0,6
65	82	110	145	86,1	18	18	112	45,5	1,5	1	80	110	1,5	1
	83	125	175	128,5	27	22	125	30,5	2,1	1	80	125	2	1
70	88	115	155	95,2	19	17,5	112	39	1,5	1	85	115	1,5	1
80	103	155	220	159,9	33	27	160	43,5	3	1,1	100	155	2,5	1



Cylindrical roller thrust bearings

Designs	864
Components	865
Double direction bearings	866
Bearing data – general	867
Dimensions	867
Tolerances	867
Misalignment	868
Cages	868
Minimum load	868
Equivalent dynamic bearing load	869
Equivalent static bearing load	869
Supplementary designations	869
Design of associated components	869
Raceways on shafts and in housings	869
Product table	870



Designs

Cylindrical roller thrust bearings are suitable for arrangements that have to support heavy axial loads. Furthermore, they are relatively insensitive to shock loads, are very stiff and require little axial space. As standard they are available as single direction bearings and can only accommodate axial loads acting in one direction.

Cylindrical roller thrust bearings are simple in form and design and are produced in single row (→ **fig. 1**) and in double row (→ **fig. 2**) designs. The bearings in the 811 and 812 series are mainly used where thrust ball bearings have insufficient load carrying capacity.

The cylindrical surface of the rollers is slightly relieved towards the ends. The resulting contact profile virtually eliminates damaging edge stresses. The bearings are of separable design; the individual components can be mounted separately.

Fig. 1

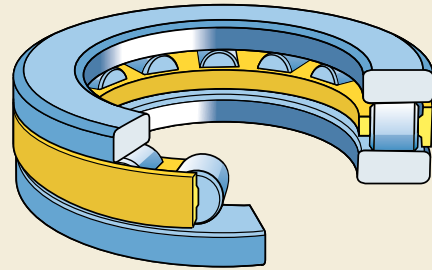
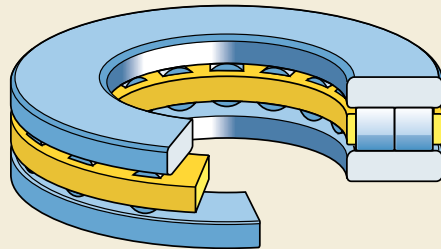

Fig. 2



Components

For applications where

- the faces of adjacent machine components can serve as raceways and slim bearing arrangements are required or
- other combinations of cylindrical roller and cage thrust assemblies and washers are required, e.g. with two shaft or housing washers,

it is possible to order

- cylindrical roller and cage thrust assemblies K (→ **fig. 3**)
- shaft washers WS (→ **fig. 4**)
- housing washers GS (→ **fig. 5**)

separately.

Fig. 3

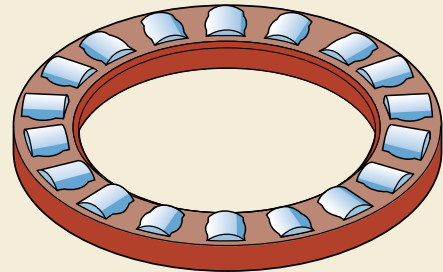

Fig. 4

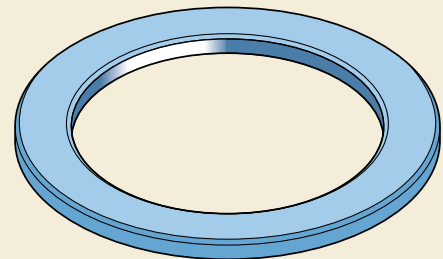
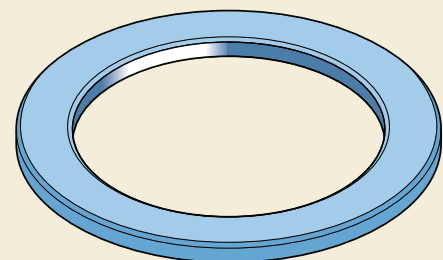

Fig. 5



Cylindrical roller thrust bearings

Double direction bearings

Double direction bearings (→ **fig. 6**) can easily be assembled by combining appropriate shaft washers in the WS 811 series or housing washers in the GS 811 series with two cylindrical roller and cage thrust assemblies in the K 811 series and a suitable intermediate washer with internal centring (**a**) or external centring (**b**).

These intermediate washers should have the same quality and hardness as the bearing washers. Recommendations for intermediate washer dimensions will be supplied on request. Guideline values for the dimensional, form and running accuracy are provided in the section “Design of associated components” on **page 869**.

Fig. 6

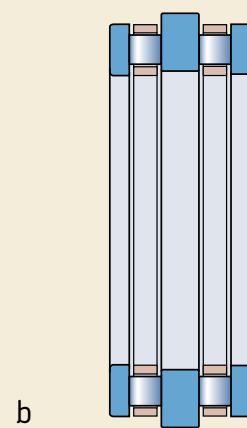
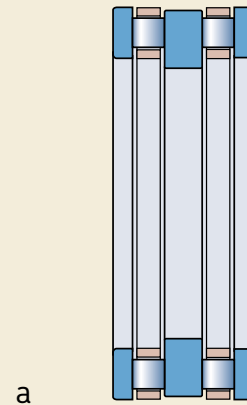

Bearing data – general

Dimensions

The boundary dimensions of cylindrical roller thrust bearings correspond to ISO 104:2002.

Tolerances

Cylindrical roller thrust bearings are produced to Normal tolerances as standard. Larger bearings are also available with increased accuracy to tolerance class P5 specifications.

The Normal and P5 tolerances are in accordance with ISO 199:1997 and can be found in **table 10** on **page 132**.

The cylindrical roller and cage thrust assemblies and the shaft and housing washers are produced to the tolerances listed in **table 1**. The values for the deviations of the various ISO tolerance grades are provided in **table 2**.

The rollers of one assembly have the same grade; the diameter variation is max. 1 µm.

Table 1

Tolerances of bearing components		
Bearing components		Tolerances
Dimensions		
Cylindrical roller and cage assembly, K		
Bore diameter	d	E11
Outside diameter	D	a13
Roller diameter	D _w	DIN 5402-1:1993
Shaft washer, WS		
Bore diameter	d	Normal tolerances
Outside diameter	d ₁	–
Thickness	B	h11
Axial runout	S _i	Normal tolerances
Housing washer, GS		
Outside diameter	D	Normal tolerances
Bore diameter	D ₁	–
Thickness	B	h11
Axial runout	S _e	Normal tolerances

Table 2

ISO tolerances								
Nominal diameter		Tolerances						
d, D		a13		h11		E11		
over	incl.	high	low	high	low	high	low	
mm		µm						
10	18	-290	-560	0	-110	+142	+32	
18	30	-300	-630	0	-130	+170	+40	
30	40	-310	-700	0	-160	+210	+50	
40	50	-320	-710	0	-160	+210	+50	
50	65	-340	-800	0	-190	+250	+60	
65	80	-360	-820	0	-190	+250	+60	
80	100	-380	-920	0	-220	+292	+72	
100	120	-410	-950	0	-220	+292	+72	
120	140	-460	-1 090	0	-250	+335	+85	
140	160	-520	-1 150	0	-250	+335	+85	
160	180	-580	-1 210	0	-250	+335	+85	
180	200	-660	-1 380	0	-290	+390	+100	
200	225	-740	-1 460	0	-290	+390	+100	
225	250	-820	-1 540	0	-290	+390	+100	
250	280	-920	-1 730	0	-320	+430	+110	
280	315	-1 050	-1 860	0	-320	+430	+110	
315	355	-1 200	-2 090	0	-360	+485	+125	
355	400	-1 350	-2 240	0	-360	+485	+125	
400	450	-1 500	-2 470	0	-400	+535	+135	
450	500	-1 650	-2 620	0	-400	+535	+135	
500	630	-1 900	-3 000	0	-440	+585	+145	
630	800	-2 100	-3 350	0	-500	+660	+150	

Cylindrical roller thrust bearings

Misalignment

Cylindrical roller thrust bearings cannot tolerate any angular misalignment between the shaft and housing, nor any errors of alignment between the support surfaces in the housing and on the shaft.

Cages

Depending on the bearing series and size, SKF cylindrical roller thrust bearings are fitted with one of the following cages (→ **fig. 7**)

- an injection moulded cage of glass fibre reinforced polyamide 6,6, designation suffix TN (a)
- a machined brass cage, designation suffix M (b).

Note

Cylindrical roller thrust bearings that incorporate a polyamide 6,6 cage can be used at operating temperatures of up to +120 °C. The cage properties will not be affected by the lubricants normally used for ball and roller bearings, with the exception of some synthetic oils or greases with synthetic base oils and lubricants containing a high proportion of EP additives when used at elevated temperatures.

For bearing arrangements, which are to operate at continuously high temperatures or under otherwise difficult conditions, it is recommended that bearings fitted with metallic cages be used.

For detailed information about the temperature resistance and the applicability of cages, please refer to the section “Cage materials”, starting on **page 140**.

Minimum load

In order to provide satisfactory operation, cylindrical roller thrust bearings, like all ball and roller bearings, must always be subjected to a given minimum load, particularly if they are to operate at high speeds or are subjected to high accelerations or rapid changes in the direction of load. Under such conditions, the inertia forces of the rollers and cage, and the friction in the lubricant, can have a detrimental influence on the rolling conditions in the bearing arrangement and may cause damaging sliding movements to occur between the rollers and raceways.

Fig. 7

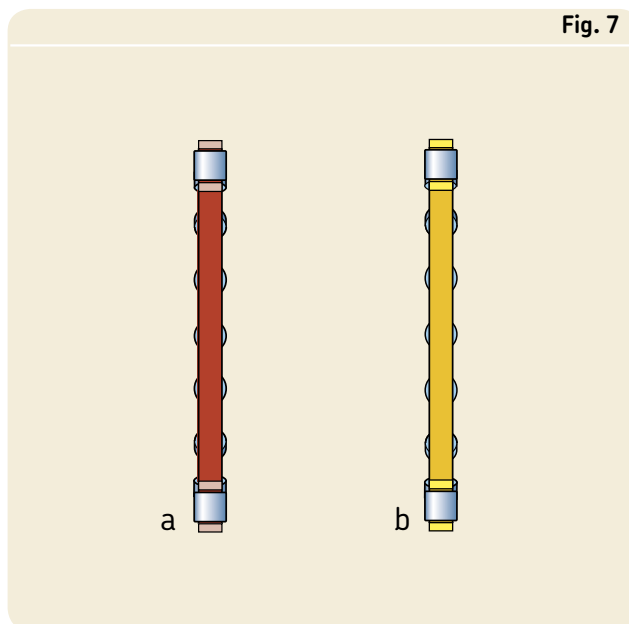

The requisite minimum load to be applied to cylindrical roller thrust bearings can be estimated using

$$F_{am} = 0,0005 C_0 + A \left(\frac{n}{1\,000} \right)^2$$

where

F_{am} = minimum axial load, kN

C_0 = basic static load rating, kN
(→ product table)

A = minimum load factor
(→ product table)

n = rotational speed, r/min

When starting up at low temperatures or when the lubricant is highly viscous, even greater minimum loads may be required. The weight of the components supported by the bearing, particularly when the shaft is vertical, together with external forces, generally exceeds the requisite minimum load. If this is not the case, the cylindrical roller thrust bearing must be preloaded, e.g. by springs or a shaft nut.

Equivalent dynamic bearing load

$$P = F_a$$

Equivalent static bearing load

$$P_0 = F_a$$

Supplementary designations

The designation suffixes used to identify certain features of SKF cylindrical roller thrust bearings are explained in the following.

- HB1** Bainite hardened shaft and housing washers
- M** Machined brass cage, roller centred
- P5** Increased dimensional and running accuracy to ISO tolerance class 5
- TN** Injection moulded cage of glass fibre reinforced polyamide 6,6, roller centred

Design of associated components

The support surfaces in the housing and on the shaft must be at right angles to the shaft axis and should provide uninterrupted support for the bearing washers across the whole extent and width of the raceways (→ **fig. 8**).

Suitable tolerances for shafts and housings which are known to provide satisfactory radial guidance for the individual thrust bearing components can be found in **table 3**.

Cylindrical roller and cage thrust assemblies are generally guided radially on the shaft in order to obtain the lowest possible sliding speed against the guiding surfaces. At high speeds radial guidance must be provided on the shaft and the guiding surface must be ground.

Raceways on shafts and in housings

Raceways on the shaft and in the housing should have the same hardness and surface finish as normally used for bearing raceways, if the load carrying capacity of the cylindrical roller and cage thrust assemblies is to be fully exploited. Details about suitable materials as well as surface hardness and surface finish can be found in the section “Raceways on shafts and in housings”, starting on **page 198**.

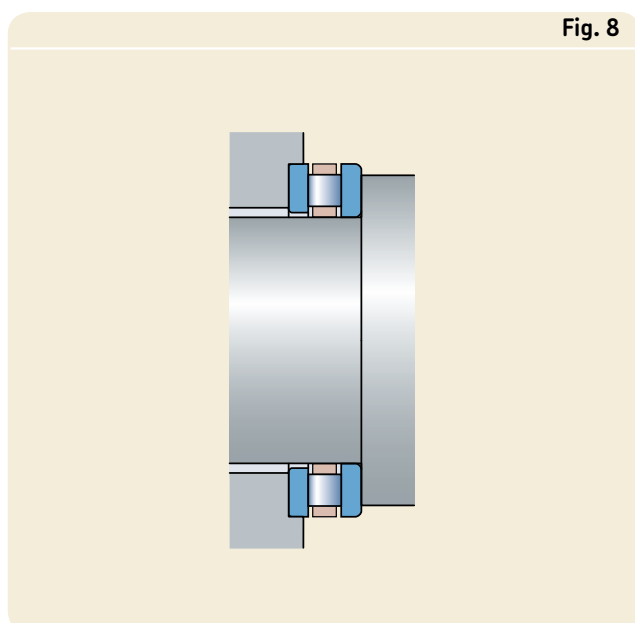

Table 3

Tolerances for shafts and housings

Bearing component Description	Prefix	Tolerances	
		Shaft	Housing bore
Cylindrical roller and cage thrust assembly	K	h8	–
Shaft washer	WS	h8	–
Housing washer	GS	–	H9

Cylindrical roller thrust bearings

d 15 – 80 mm

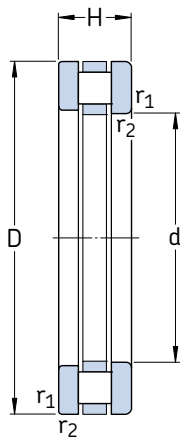

Complete bearing

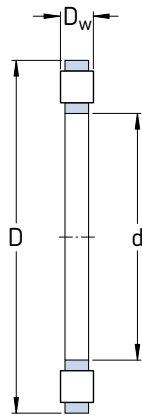

Cylindrical roller and cage thrust assembly

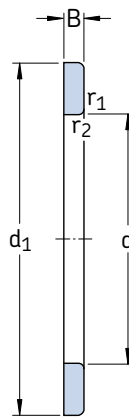

Shaft washer

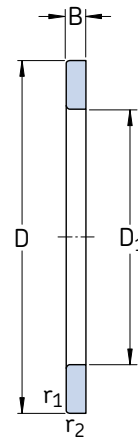

Housing washer

Principal dimensions			Basic load ratings dynamic static		Fatigue load limit	Minimum load factor	Speed ratings Reference speed Limiting speed		Mass	Designation
d	D	H	C	C ₀	P _u	A				
mm			kN		kN	–	r/min		kg	–
15	28	9	11,2	27	2,45	0,000058	4 300	8 500	0,024	81102 TN
17	30	9	12,2	31,5	2,85	0,000079	4 300	8 500	0,027	81103 TN
20	35	10	18,6	48	4,65	0,00018	3 800	7 500	0,037	81104 TN
25	42	11	25	69,5	6,80	0,00039	3 200	6 300	0,053	81105 TN
30	47 52	11 16	27 50	78 134	7,65 13,4	0,00049 0,0014	3 000 2 400	6 000 4 800	0,057 0,12	81106 TN 81206 TN
35	52 62	12 18	29 62	93 190	9,15 19,3	0,00069 0,0029	2 800 2 000	5 600 4 000	0,073 0,20	81107 TN 81207 TN
40	60 68	13 19	43 83	137 255	13,7 26,5	0,0015 0,0052	2 400 1 900	5 000 3 800	0,11 0,25	81108 TN 81208 TN
45	65 73	14 20	45 83	153 255	15,3 26,5	0,0019 0,0058	2 200 1 800	4 500 3 600	0,13 0,29	81109 TN 81209 TN
50	70 78	14 22	47,5 91,5	166 300	16,6 31	0,0022 0,0072	2 200 1 700	4 300 3 400	0,14 0,36	81110 TN 81210 TN
55	78 90	16 25	69,5 122	285 390	29 40	0,0065 0,012	1 900 1 400	3 800 2 800	0,22 0,57	81111 TN 81211 TN
60	85 95	17 26	80 137	300 465	30,5 47,5	0,0072 0,017	1 800 1 400	3 600 2 800	0,27 0,64	81112 TN 81212 TN
65	90 100	18 27	83 140	320 490	32,5 50	0,0082 0,019	1 700 1 300	3 400 2 600	0,31 0,72	81113 TN 81213 TN
70	95 105	18 27	86,5 146	345 530	34,5 55	0,0095 0,022	1 600 1 300	3 200 2 600	0,33 0,77	81114 TN 81214 TN
75	100 110	19 27	83 137	335 490	34 50	0,0067 0,015	1 600 1 200	3 200 2 400	0,39 0,80	81115 TN 81215 TN
80	105 115	19 28	81,5 160	335 610	34 63	0,0072 0,029	1 500 1 200	3 000 2 400	0,40 0,90	81116 TN 81216 TN

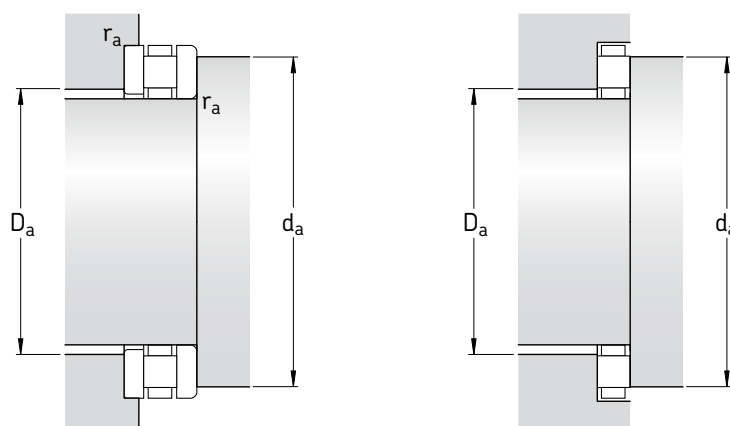

Dimensions						Abutment and fillet dimensions			Designation of components		
d	d ₁ ~	D ₁ ~	B	D _w	r _{1,2} min	d _a min	D _a max	r _a max	Cylindrical roller and cage thrust assembly	Shaft washer	Housing washer
mm						mm			-		
15	28	16	2,75	3,5	0,3	27	16	0,3	K 81102 TN	WS 81102	GS 81102
17	30	18	2,75	3,5	0,3	29	18	0,3	K 81103 TN	WS 81103	GS 81103
20	35	21	2,75	4,5	0,3	34	21	0,3	K 81104 TN	WS 81104	GS 81104
25	42	26	3	5	0,6	41	26	0,6	K 81105 TN	WS 81105	GS 81105
30	47	32	3	5	0,6	46	31	0,6	K 81106 TN	WS 81106	GS 81106
	52	32	4,25	7,5	0,6	50	31	0,6	K 81206 TN	WS 81206	GS 81206
35	52	37	3,5	5	0,6	51	36	0,6	K 81107 TN	WS 81107	GS 81107
	62	37	5,25	7,5	1	58	39	1	K 81207 TN	WS 81207	GS 81207
40	60	42	3,5	6	0,6	58	42	0,6	K 81108 TN	WS 81108	GS 81108
	68	42	5	9	1	66	43	1	K 81208 TN	WS 81208	GS 81208
45	65	47	4	6	0,6	63	47	0,6	K 81109 TN	WS 81109	GS 81109
	73	47	5,5	9	1	70	48	1	K 81209 TN	WS 81209	GS 81209
50	70	52	4	6	0,6	68	52	0,6	K 81110 TN	WS 81110	GS 81110
	78	52	6,5	9	1	75	53	1	K 81210 TN	WS 81210	GS 81210
55	78	57	5	6	0,6	77	56	0,6	K 81111 TN	WS 81111	GS 81111
	90	57	7	11	1	85	59	1	K 81211 TN	WS 81211	GS 81211
60	85	62	4,75	7,5	1	82	62	1	K 81112 TN	WS 81112	GS 81112
	95	62	7,5	11	1	91	64	1	K 81212 TN	WS 81212	GS 81212
65	90	67	5,25	7,5	1	87	67	1	K 81113 TN	WS 81113	GS 81113
	100	67	8	11	1	96	69	1	K 81213 TN	WS 81213	GS 81213
70	95	72	5,25	7,5	1	92	72	1	K 81114 TN	WS 81114	GS 81114
	105	72	8	11	1	102	74	1	K 81214 TN	WS 81214	GS 81214
75	100	77	5,75	7,5	1	97	78	1	K 81115 TN	WS 81115	GS 81115
	110	77	8	11	1	106	79	1	K 81215 TN	WS 81215	GS 81215
80	105	82	5,75	7,5	1	102	83	1	K 81116 TN	WS 81116	GS 81116
	115	82	8,5	11	1	112	84	1	K 81216 TN	WS 81216	GS 81216

Cylindrical roller thrust bearings

d 85 – 220 mm

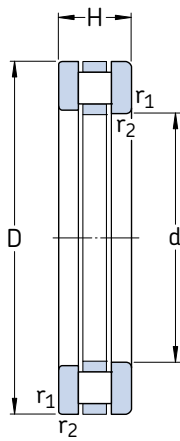

Complete bearing

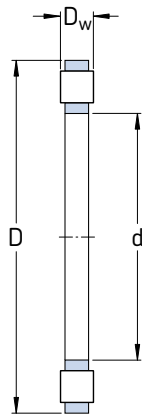

Cylindrical roller and cage thrust assembly

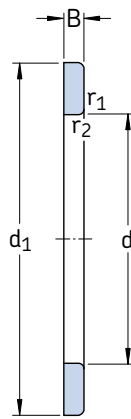

Shaft washer

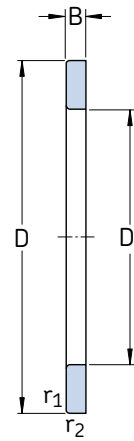

Housing washer

Principal dimensions			Basic load ratings		Fatigue load limit P_u	Minimum load factor A	Speed ratings		Mass	Designation
d	D	H	dynamic C	static C_0			Reference speed	Limiting speed		
mm			kN		kN	–	r/min		kg	–
85	110	19	88	365	37,5	0,010	1 500	3 000	0,42	81117 TN
	125	31	170	640	67	0,024	1 100	2 200	1,25	81217 TN
90	120	22	110	450	45,5	0,013	1 300	2 600	0,62	81118 TN
	135	35	232	865	90	0,059	1 000	2 000	1,75	81218 TN
100	135	25	156	630	62	0,027	1 200	2 400	0,95	81120 TN
	150	38	270	1 060	104	0,055	900	1 800	2,20	81220 TN
110	145	25	163	680	65,5	0,031	1 100	2 200	1,05	81122 TN
	160	38	260	1 000	98	0,066	850	1 700	2,30	81222 TN
120	155	25	170	735	68	0,036	1 100	2 200	1,10	81124 TN
	170	39	270	1 100	104	0,074	800	1 600	2,55	81224 TN
130	170	30	200	880	81,5	0,048	950	1 900	1,70	81126 TN
	190	45	380	1 460	137	0,17	700	1 400	4,20	81226 TN
140	180	31	208	930	85	0,057	900	1 800	1,90	81128 TN
	200	46	360	1 400	129	0,16	700	1 400	4,55	81228 M
150	190	31	212	1 000	88	0,064	850	1 700	2,00	81130 TN
	215	50	465	1 900	170	0,29	630	1 300	5,90	81230 M
160	200	31	216	1 020	90	0,083	850	1 700	2,20	81132 TN
	225	51	480	2 000	176	0,32	600	1 200	6,20	81232 M
170	215	34	285	1 340	118	0,11	800	1 600	2,95	81134 TN
	240	55	540	2 280	200	0,42	560	1 100	7,70	81234 M
180	225	34	270	1 270	110	0,13	750	1 500	3,05	81136 M
	250	56	550	2 400	204	0,46	560	1 100	8,25	81236 M
190	240	37	310	1 460	125	0,17	700	1 400	3,85	81138 M
	270	62	695	2 900	250	0,67	500	1 000	10,5	81238 M
200	250	37	310	1 500	127	0,18	700	1 400	4,00	81140 M
	280	62	720	3 100	255	0,77	500	1 000	12,0	81240 M
220	270	37	335	1 700	137	0,23	670	1 300	4,50	81144 M
	300	63	750	3 350	275	0,90	480	950	13,0	81244 M

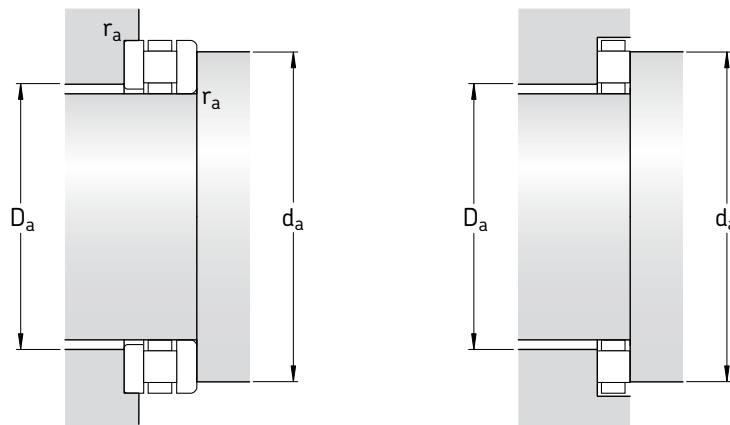

Dimensions						Abutment and fillet dimensions			Designation of components		
d	d ₁ ~	D ₁ ~	B	D _w	r _{1,2} min	d _a min	D _a max	r _a max	Cylindrical roller and cage thrust assembly	Shaft washer	Housing washer
mm						mm			-		
85	110	87	5,75	7,5	1	108	87	1	K 81117 TN	WS 81117	GS 81117
	125	88	9,5	12	1	119	90	1	K 81217 TN	WS 81217	GS 81217
90	120	92	6,5	9	1	117	93	1	K 81118 TN	WS 81118	GS 81118
	135	93	10,5	14	1,1	129	95	1	K 81218 TN	WS 81218	GS 81218
100	135	102	7	11	1	131	104	1	K 81120 TN	WS 81120	GS 81120
	150	103	11,5	15	1,1	142	107	1	K 81220 TN	WS 81220	GS 81220
110	145	112	7	11	1	141	114	1	K 81122 TN	WS 81122	GS 81122
	160	113	11,5	15	1,1	152	117	1	K 81222 TN	WS 81222	GS 81222
120	155	122	7	11	1	151	124	1	K 81124 TN	WS 81124	GS 81124
	170	123	12	15	1,1	162	127	1	K 81224 TN	WS 81224	GS 81224
130	170	132	9	12	1	165	135	1	K 81126 TN	WS 81126	GS 81126
	187	133	13	19	1,5	181	137	1,5	K 81226 TN	WS 81226	GS 81226
140	178	142	9,5	12	1	175	145	1	K 81128 TN	WS 81128	GS 81128
	197	143	13,5	19	1,5	191	147	1,5	K 81228 M	WS 81228	GS 81228
150	188	152	9,5	12	1	185	155	1	K 81130 TN	WS 81130	GS 81130
	212	153	14,5	21	1,5	211	158	1,5	K 81230 M	WS 81230	GS 81230
160	198	162	9,5	12	1	195	165	1	K 81132 TN	WS 81132	GS 81132
	222	163	15	21	1,5	220	168	1,5	K 81232 M	WS 81232	GS 81232
170	213	172	10	14	1,1	209	176	1	K 81134 TN	WS 81134	GS 81134
	237	173	16,5	22	1,5	235	180	1,5	K 81234 M	WS 81234	GS 81234
180	222	183	10	14	1,1	219	185	1	K 81136 M	WS 81136	GS 81136
	247	183	17	22	1,5	245	190	1,5	K 81236 M	WS 81236	GS 81236
190	237	193	11	15	1,1	233	197	1	K 81138 M	WS 81138	GS 81138
	267	194	18	26	2	265	200	2	K 81238 M	WS 81238	GS 81238
200	247	203	11	15	1,1	243	206	1	K 81140 M	WS 81140	GS 81140
	277	204	18	26	2	275	210	2	K 81240 M	WS 81240	GS 81240
220	267	223	11	15	1,1	263	226	1	K 81144 M	WS 81144	GS 81144
	297	224	18,5	26	2	296	230	2	K 81244 M	WS 81244	GS 81244

Cylindrical roller thrust bearings

d 240 – 630 mm

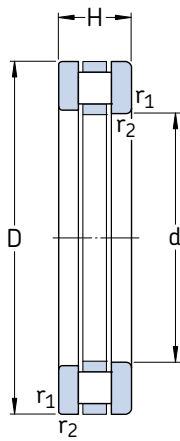

Complete bearing

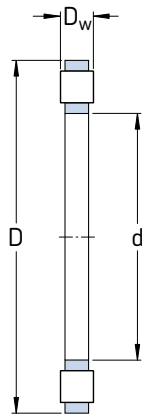

Cylindrical roller and cage thrust assembly

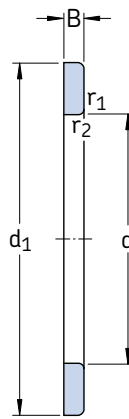

Shaft washer

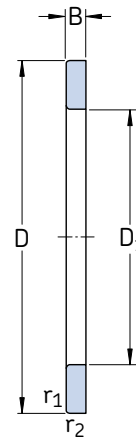

Housing washer

Principal dimensions			Basic load ratings		Fatigue load limit P_u	Minimum load factor A	Speed ratings		Mass	Designation
d	D	H	dynamic C	static C_0			Reference speed	Limiting speed		
mm			kN		kN	–	r/min		kg	–
240	300	45	475	2 450	196	0,48	560	1 100	7,25	81148 M
	340	78	1 100	4 900	390	1,9	400	800	22,0	81248 M
260	320	45	490	2 600	200	0,54	530	1 100	7,85	81152 M
	360	79	1 140	5 300	415	2,2	380	750	24,0	81252 M
280	350	53	680	3 550	275	1	480	950	10,5	81156 M
	380	80	1 160	5 500	425	2,4	360	750	26,0	81256 M
300	380	62	850	4 400	335	1,5	430	850	16,5	81160 M
	420	95	1 530	7 200	540	4,1	320	630	40,5	81260 M
320	400	63	880	4 650	345	1,7	400	800	18,0	81164 M
	440	95	1 560	7 500	550	4,5	300	600	42,5	81264 M
340	420	64	900	4 900	355	1,9	380	800	19,5	81168 M
	460	96	1 630	8 000	585	5,1	300	600	47,0	81268 M
360	440	65	900	4 900	355	1,9	380	750	19,5	81172 M
	500	110	2 160	10 400	750	8,7	260	530	65,5	81272 M
380	460	65	930	5 300	375	2,2	360	750	22,0	81176 M
400	480	65	965	5 600	390	2,5	360	700	23,0	81180 M
420	500	65	980	5 850	400	2,7	340	700	24,0	81184 M
440	540	80	1 430	8 000	550	5,1	300	600	39,5	81188 M
460	560	80	1 460	8 500	570	5,8	300	600	41,0	81192 M
480	580	80	1 460	8 650	585	6	280	560	43,0	81196 M
500	600	80	1 560	9 300	620	6,9	280	560	44,0	811/500 M
530	640	85	1 730	10 600	680	9	260	530	55,5	811/530 M
560	670	85	1 760	11 100	710	9,7	260	500	58,0	811/560 M
600	710	85	1 800	11 600	720	11	240	500	62,0	811/600 M
630	750	95	2 160	13 700	865	15	220	450	80,0	811/630 M

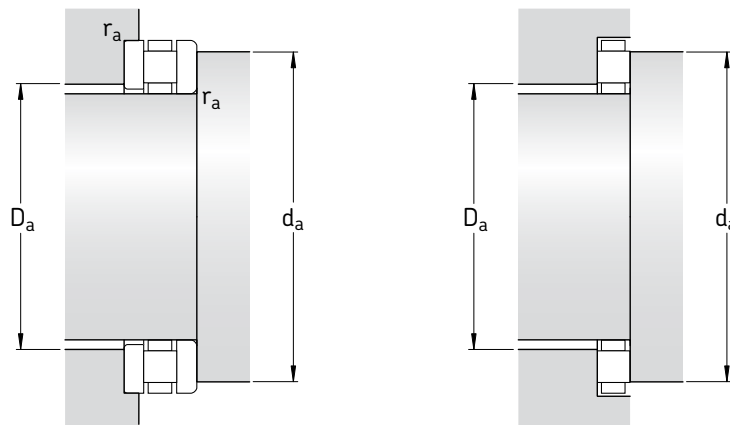

Dimensions						Abutment and fillet dimensions			Designation of components																																																																																																																																																																																																																																																										
d	d_1	D_1	B	D_w	$r_{1,2}$ min	d_a min	D_a max	r_a max	Cylindrical roller and cage thrust assembly	Shaft washer	Housing washer																																																																																																																																																																																																																																																								
mm						mm			-																																																																																																																																																																																																																																																										
240	297	243	13,5	18	1,5	296	248	1,5	K 81148 M K 81248 M	WS 81148 WS 81248	GS 81148 GS 81248																																																																																																																																																																																																																																																								
	335	244	23	32	2,1	335	261	2				260	317	263	13,5	18	1,5	316	268	1,5	K 81152 M K 81252 M	WS 81152 WS 81252	GS 81152 GS 81252	355	264	23,5	32	2,1	353	280	2	280	347	283	15,5	22	1,5	346	288	1,5	K 81156 M K 81256 M	WS 81156 WS 81256	GS 81156 GS 81256	375	284	24	32	2	373	300	2	300	376	304	18,5	25	2	373	315	2	K 81160 M K 81260 M	WS 81160 WS 81260	GS 81160 GS 81260	415	304	28,5	38	3	413	328	2,5	320	396	324	19	25	2	394	334	2	K 81164 M K 81264 M	WS 81164 WS 81264	GS 81164 GS 81264	435	325	28,5	38	3	434	348	2,5	340	416	344	19,5	25	2	414	354	2	K 81168 M K 81268 M	WS 81168 WS 81268	GS 81168 GS 81268	455	345	29	38	3	452	367	2,5	360	436	364	20	25	2	434	374	2	K 81172 M K 81272 M	WS 81172 WS 81272	GS 81172 GS 81272	495	365	32,5	45	4	492	393	3	380	456	384	20	25	2	453	393	2	K 81176 M	WS 81176	GS 81176	400	476	404	20	25	2	473	413	2	K 81180 M	WS 81180	GS 81180	420	495	424	20	25	2	493	433	2	K 81184 M	WS 81184	GS 81184	440	535	444	24	32	2,1	533	459	2	K 81188 M	WS 81188	GS 81188	460	555	464	24	32	2,1	553	479	2	K 81192 M	WS 81192	GS 81192	480	575	484	24	32	2,1	573	500	2	K 81196 M	WS 81196	GS 81196	500	595	505	24	32	2,1	592	519	2	K 811/500 M	WS 811/500	GS 811/500	530	635	535	25,5	34	3	632	554	2,5	K 811/530 M	WS 811/530	GS 811/530	560	665	565	25,5	34	3	662	584	2,5	K 811/560 M	WS 811/560	GS 811/560	600	705	605	25,5	34	3	702	624	2,5	K 811/600 M	WS 811/600	GS 811/600	630	746	634	28,5	38	3	732	650
260	317	263	13,5	18	1,5	316	268	1,5	K 81152 M K 81252 M	WS 81152 WS 81252	GS 81152 GS 81252																																																																																																																																																																																																																																																								
	355	264	23,5	32	2,1	353	280	2				280	347	283	15,5	22	1,5	346	288	1,5	K 81156 M K 81256 M	WS 81156 WS 81256	GS 81156 GS 81256	375	284	24	32	2	373	300	2	300	376	304	18,5	25	2	373	315	2	K 81160 M K 81260 M	WS 81160 WS 81260	GS 81160 GS 81260	415	304	28,5	38	3	413	328	2,5	320	396	324	19	25	2	394	334	2	K 81164 M K 81264 M	WS 81164 WS 81264	GS 81164 GS 81264	435	325	28,5	38	3	434	348	2,5	340	416	344	19,5	25	2	414	354	2	K 81168 M K 81268 M	WS 81168 WS 81268	GS 81168 GS 81268	455	345	29	38	3	452	367	2,5	360	436	364	20	25	2	434	374	2	K 81172 M K 81272 M	WS 81172 WS 81272	GS 81172 GS 81272	495	365	32,5	45	4	492	393	3	380	456	384	20	25	2	453	393	2	K 81176 M	WS 81176	GS 81176	400	476	404	20	25	2	473	413	2	K 81180 M	WS 81180	GS 81180	420	495	424	20	25	2	493	433	2	K 81184 M	WS 81184	GS 81184	440	535	444	24	32	2,1	533	459	2	K 81188 M	WS 81188	GS 81188	460	555	464	24	32	2,1	553	479	2	K 81192 M	WS 81192	GS 81192	480	575	484	24	32	2,1	573	500	2	K 81196 M	WS 81196	GS 81196	500	595	505	24	32	2,1	592	519	2	K 811/500 M	WS 811/500	GS 811/500	530	635	535	25,5	34	3	632	554	2,5	K 811/530 M	WS 811/530	GS 811/530	560	665	565	25,5	34	3	662	584	2,5	K 811/560 M	WS 811/560	GS 811/560	600	705	605	25,5	34	3	702	624	2,5	K 811/600 M	WS 811/600	GS 811/600	630	746	634	28,5	38	3	732	650	2,5	K 811/630 M	WS 811/630	GS 811/630																
280	347	283	15,5	22	1,5	346	288	1,5	K 81156 M K 81256 M	WS 81156 WS 81256	GS 81156 GS 81256																																																																																																																																																																																																																																																								
	375	284	24	32	2	373	300	2				300	376	304	18,5	25	2	373	315	2	K 81160 M K 81260 M	WS 81160 WS 81260	GS 81160 GS 81260	415	304	28,5	38	3	413	328	2,5	320	396	324	19	25	2	394	334	2	K 81164 M K 81264 M	WS 81164 WS 81264	GS 81164 GS 81264	435	325	28,5	38	3	434	348	2,5	340	416	344	19,5	25	2	414	354	2	K 81168 M K 81268 M	WS 81168 WS 81268	GS 81168 GS 81268	455	345	29	38	3	452	367	2,5	360	436	364	20	25	2	434	374	2	K 81172 M K 81272 M	WS 81172 WS 81272	GS 81172 GS 81272	495	365	32,5	45	4	492	393	3	380	456	384	20	25	2	453	393	2	K 81176 M	WS 81176	GS 81176	400	476	404	20	25	2	473	413	2	K 81180 M	WS 81180	GS 81180	420	495	424	20	25	2	493	433	2	K 81184 M	WS 81184	GS 81184	440	535	444	24	32	2,1	533	459	2	K 81188 M	WS 81188	GS 81188	460	555	464	24	32	2,1	553	479	2	K 81192 M	WS 81192	GS 81192	480	575	484	24	32	2,1	573	500	2	K 81196 M	WS 81196	GS 81196	500	595	505	24	32	2,1	592	519	2	K 811/500 M	WS 811/500	GS 811/500	530	635	535	25,5	34	3	632	554	2,5	K 811/530 M	WS 811/530	GS 811/530	560	665	565	25,5	34	3	662	584	2,5	K 811/560 M	WS 811/560	GS 811/560	600	705	605	25,5	34	3	702	624	2,5	K 811/600 M	WS 811/600	GS 811/600	630	746	634	28,5	38	3	732	650	2,5	K 811/630 M	WS 811/630	GS 811/630																																				
300	376	304	18,5	25	2	373	315	2	K 81160 M K 81260 M	WS 81160 WS 81260	GS 81160 GS 81260																																																																																																																																																																																																																																																								
	415	304	28,5	38	3	413	328	2,5				320	396	324	19	25	2	394	334	2	K 81164 M K 81264 M	WS 81164 WS 81264	GS 81164 GS 81264	435	325	28,5	38	3	434	348	2,5	340	416	344	19,5	25	2	414	354	2	K 81168 M K 81268 M	WS 81168 WS 81268	GS 81168 GS 81268	455	345	29	38	3	452	367	2,5	360	436	364	20	25	2	434	374	2	K 81172 M K 81272 M	WS 81172 WS 81272	GS 81172 GS 81272	495	365	32,5	45	4	492	393	3	380	456	384	20	25	2	453	393	2	K 81176 M	WS 81176	GS 81176	400	476	404	20	25	2	473	413	2	K 81180 M	WS 81180	GS 81180	420	495	424	20	25	2	493	433	2	K 81184 M	WS 81184	GS 81184	440	535	444	24	32	2,1	533	459	2	K 81188 M	WS 81188	GS 81188	460	555	464	24	32	2,1	553	479	2	K 81192 M	WS 81192	GS 81192	480	575	484	24	32	2,1	573	500	2	K 81196 M	WS 81196	GS 81196	500	595	505	24	32	2,1	592	519	2	K 811/500 M	WS 811/500	GS 811/500	530	635	535	25,5	34	3	632	554	2,5	K 811/530 M	WS 811/530	GS 811/530	560	665	565	25,5	34	3	662	584	2,5	K 811/560 M	WS 811/560	GS 811/560	600	705	605	25,5	34	3	702	624	2,5	K 811/600 M	WS 811/600	GS 811/600	630	746	634	28,5	38	3	732	650	2,5	K 811/630 M	WS 811/630	GS 811/630																																																								
320	396	324	19	25	2	394	334	2	K 81164 M K 81264 M	WS 81164 WS 81264	GS 81164 GS 81264																																																																																																																																																																																																																																																								
	435	325	28,5	38	3	434	348	2,5				340	416	344	19,5	25	2	414	354	2	K 81168 M K 81268 M	WS 81168 WS 81268	GS 81168 GS 81268	455	345	29	38	3	452	367	2,5	360	436	364	20	25	2	434	374	2	K 81172 M K 81272 M	WS 81172 WS 81272	GS 81172 GS 81272	495	365	32,5	45	4	492	393	3	380	456	384	20	25	2	453	393	2	K 81176 M	WS 81176	GS 81176	400	476	404	20	25	2	473	413	2	K 81180 M	WS 81180	GS 81180	420	495	424	20	25	2	493	433	2	K 81184 M	WS 81184	GS 81184	440	535	444	24	32	2,1	533	459	2	K 81188 M	WS 81188	GS 81188	460	555	464	24	32	2,1	553	479	2	K 81192 M	WS 81192	GS 81192	480	575	484	24	32	2,1	573	500	2	K 81196 M	WS 81196	GS 81196	500	595	505	24	32	2,1	592	519	2	K 811/500 M	WS 811/500	GS 811/500	530	635	535	25,5	34	3	632	554	2,5	K 811/530 M	WS 811/530	GS 811/530	560	665	565	25,5	34	3	662	584	2,5	K 811/560 M	WS 811/560	GS 811/560	600	705	605	25,5	34	3	702	624	2,5	K 811/600 M	WS 811/600	GS 811/600	630	746	634	28,5	38	3	732	650	2,5	K 811/630 M	WS 811/630	GS 811/630																																																																												
340	416	344	19,5	25	2	414	354	2	K 81168 M K 81268 M	WS 81168 WS 81268	GS 81168 GS 81268																																																																																																																																																																																																																																																								
	455	345	29	38	3	452	367	2,5				360	436	364	20	25	2	434	374	2	K 81172 M K 81272 M	WS 81172 WS 81272	GS 81172 GS 81272	495	365	32,5	45	4	492	393	3	380	456	384	20	25	2	453	393	2	K 81176 M	WS 81176	GS 81176	400	476	404	20	25	2	473	413	2	K 81180 M	WS 81180	GS 81180	420	495	424	20	25	2	493	433	2	K 81184 M	WS 81184	GS 81184	440	535	444	24	32	2,1	533	459	2	K 81188 M	WS 81188	GS 81188	460	555	464	24	32	2,1	553	479	2	K 81192 M	WS 81192	GS 81192	480	575	484	24	32	2,1	573	500	2	K 81196 M	WS 81196	GS 81196	500	595	505	24	32	2,1	592	519	2	K 811/500 M	WS 811/500	GS 811/500	530	635	535	25,5	34	3	632	554	2,5	K 811/530 M	WS 811/530	GS 811/530	560	665	565	25,5	34	3	662	584	2,5	K 811/560 M	WS 811/560	GS 811/560	600	705	605	25,5	34	3	702	624	2,5	K 811/600 M	WS 811/600	GS 811/600	630	746	634	28,5	38	3	732	650	2,5	K 811/630 M	WS 811/630	GS 811/630																																																																																																
360	436	364	20	25	2	434	374	2	K 81172 M K 81272 M	WS 81172 WS 81272	GS 81172 GS 81272																																																																																																																																																																																																																																																								
	495	365	32,5	45	4	492	393	3				380	456	384	20	25	2	453	393	2	K 81176 M	WS 81176	GS 81176	400	476	404	20	25	2	473	413	2	K 81180 M	WS 81180	GS 81180	420	495	424	20	25	2	493	433	2	K 81184 M	WS 81184	GS 81184	440	535	444	24	32	2,1	533	459	2	K 81188 M	WS 81188	GS 81188	460	555	464	24	32	2,1	553	479	2	K 81192 M	WS 81192	GS 81192	480	575	484	24	32	2,1	573	500	2	K 81196 M	WS 81196	GS 81196	500	595	505	24	32	2,1	592	519	2	K 811/500 M	WS 811/500	GS 811/500	530	635	535	25,5	34	3	632	554	2,5	K 811/530 M	WS 811/530	GS 811/530	560	665	565	25,5	34	3	662	584	2,5	K 811/560 M	WS 811/560	GS 811/560	600	705	605	25,5	34	3	702	624	2,5	K 811/600 M	WS 811/600	GS 811/600	630	746	634	28,5	38	3	732	650	2,5	K 811/630 M	WS 811/630	GS 811/630																																																																																																																				
380	456	384	20	25	2	453	393	2	K 81176 M	WS 81176	GS 81176																																																																																																																																																																																																																																																								
400	476	404	20	25	2	473	413	2	K 81180 M	WS 81180	GS 81180																																																																																																																																																																																																																																																								
420	495	424	20	25	2	493	433	2	K 81184 M	WS 81184	GS 81184																																																																																																																																																																																																																																																								
440	535	444	24	32	2,1	533	459	2	K 81188 M	WS 81188	GS 81188																																																																																																																																																																																																																																																								
460	555	464	24	32	2,1	553	479	2	K 81192 M	WS 81192	GS 81192																																																																																																																																																																																																																																																								
480	575	484	24	32	2,1	573	500	2	K 81196 M	WS 81196	GS 81196																																																																																																																																																																																																																																																								
500	595	505	24	32	2,1	592	519	2	K 811/500 M	WS 811/500	GS 811/500																																																																																																																																																																																																																																																								
530	635	535	25,5	34	3	632	554	2,5	K 811/530 M	WS 811/530	GS 811/530																																																																																																																																																																																																																																																								
560	665	565	25,5	34	3	662	584	2,5	K 811/560 M	WS 811/560	GS 811/560																																																																																																																																																																																																																																																								
600	705	605	25,5	34	3	702	624	2,5	K 811/600 M	WS 811/600	GS 811/600																																																																																																																																																																																																																																																								
630	746	634	28,5	38	3	732	650	2,5	K 811/630 M	WS 811/630	GS 811/630																																																																																																																																																																																																																																																								



Spherical roller thrust bearings

Designs	878
SKF Explorer class bearings	878
Bearing data – general	879
Dimensions.....	879
Tolerances.....	879
Misalignment.....	879
Influence of operating temperatures on bearing material	879
Minimum load.....	880
Equivalent dynamic bearing load.....	880
Equivalent static bearing load.....	880
Supplementary designations.....	880
Design of associated components	881
Lubrication	882
Mounting.....	883
Product table	884



Designs

In spherical roller thrust bearings the load is transmitted from one raceway to the other at an angle to the bearing axis (→ **fig. 1**). The bearings are therefore suitable to accommodate radial loads in addition to simultaneously acting axial loads. Another important characteristic of spherical roller thrust bearings is their self-aligning capability. This makes the bearings insensitive to shaft deflection and misalignment of the shaft relative to the housing.

SKF spherical roller thrust bearings incorporate a large number of asymmetrical rollers and have specially designed raceways with an optimum conformity. They can therefore support very heavy axial loads and permit relatively high speed operation.

Depending on the bearing series and size, SKF spherical roller thrust bearings are produced to two designs. Bearings up to and including size 68 identified by the designation suffix E have a pressed window-type cage of sheet steel. The cage, rollers and shaft washer form a non-separable assembly (→ **fig. 2**). All other bearings have a machined brass or steel cage, which is guided by a sleeve held in the shaft washer bore (→ **fig. 3**). The shaft washer, cage and rollers form a non-separable unit.

SKF Explorer class bearings

High performance SKF Explorer spherical roller thrust bearings are shown with an asterisk in the product table. SKF Explorer bearings retain the designation of the earlier standard bearings, e.g. 29330 E. However, each bearing and its box are marked with the name "EXPLORER".

Fig. 1

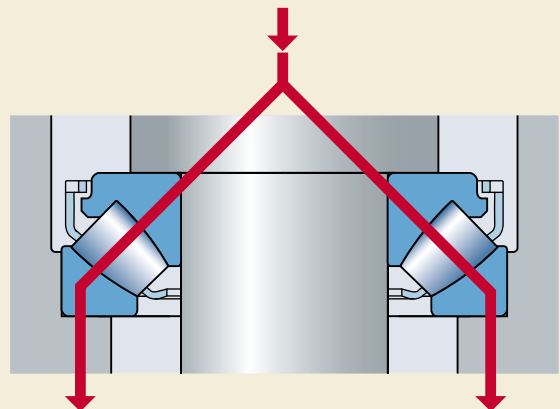

Fig. 2

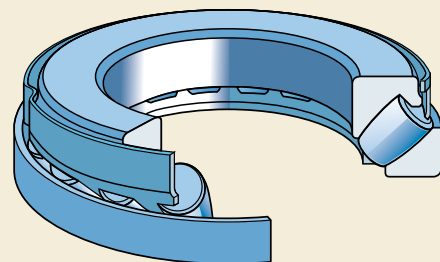
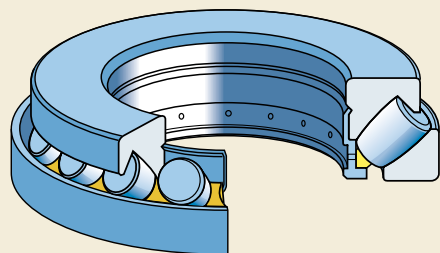

Fig. 3



Bearing data – general

Dimensions

The boundary dimensions of SKF spherical roller thrust bearings are in accordance with ISO 104:2002.

Tolerances

SKF spherical roller thrust bearings are produced as standard to Normal tolerances as specified in ISO 199:1997. However the tolerances for the total height of

- SKF standard bearings are more than 50 % tighter
- SKF Explorer bearings are 75 % tighter

than specified by ISO.

The tolerance values can be found in **table 10** on **page 132**.

Misalignment

By virtue of their design, spherical roller thrust bearings are self-aligning, i.e. they tolerate misalignment of the shaft relative to the housing, and shaft deflections during operation (→ **fig. 4**). Whether the permissible misalignment can be fully exploited depends on the design of the bearing arrangement, the type of seal etc.

The permissible misalignment is reduced as the load increases. The values indicated in **table 1** can be permitted provided there is constant misalignment and a rotating shaft washer. When designing bearing arrangements, it is advisable to contact the SKF application engineering service if the following conditions occur:

- Rotating housing washer in combination with misalignment.
- The shaft wobbles in relation to the housing.

Influence of operating temperatures on bearing material

All SKF spherical roller thrust bearings undergo a special heat treatment so that they can be operated at higher temperatures for longer periods, without the occurrence of inadmissible dimensional changes. For example, a temperature of +200 °C for 2 500 h, or for shorter

Fig. 4

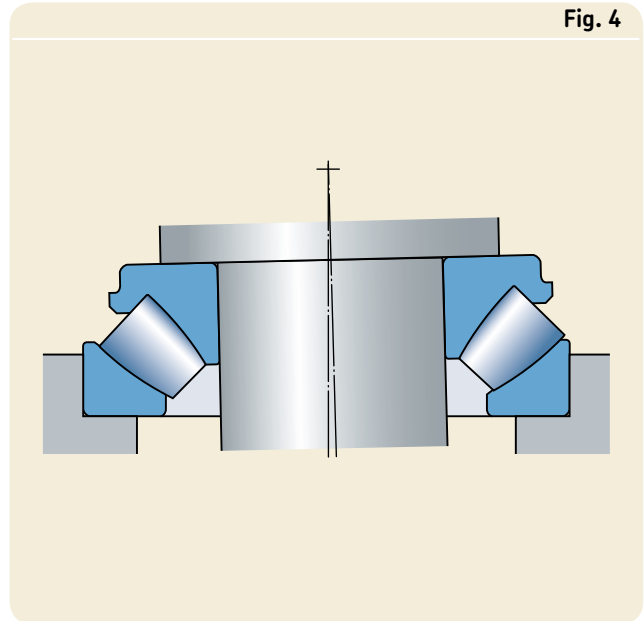

Table 1

Bearing series	Permissible angular misalignment		
	Permissible misalignment when bearing load $P_0^{1)}$		
	$< 0,05 C_0$	$> 0,05 C_0$	$> 0,3 C_0$
–	degrees		
292 (E)	2	1,5	1
293 (E)	2,5	1,5	0,3
294 (E)	3	1,5	0,3

¹⁾ $P_0 = F_a + 2,7 F_r$

periods at even higher temperatures, is permitted.

Spherical roller thrust bearings

Minimum load

In order to provide satisfactory operation, spherical roller thrust bearings, like all ball and roller bearings, must always be subjected to a given minimum load, particularly if they are to operate at high speeds or are subjected to high accelerations or rapid changes in the direction of the load. Under such conditions, the inertia forces of the rollers and cage, and the friction in the lubricant, can have a detrimental influence on the rolling conditions in the bearing arrangement and may cause damaging sliding movements to occur between the rollers and raceways.

The requisite minimum axial load to be applied to spherical roller thrust bearings can be estimated using

$$F_{am} = 1,8 F_r + A \left(\frac{n}{1\,000} \right)^2$$

where

F_{am} = minimum axial load, kN

F_r = radial component of the load for bearings subjected to combined load, kN

C_0 = basic static load rating, kN
(→ product table)

A = minimum load factor
(→ product table)

n = rotational speed, r/min

If $1,8 F_r < 0,0005 C_0$ then $0,0005 C_0$ should be used in the above equation instead of $1,8 F_r$.

At speeds higher than the reference speed or when starting up at low temperatures, or when the lubricant is highly viscous, even greater minimum loads may be required. The weight of the components supported by the bearing, together with external forces, generally exceeds the requisite minimum load. If this is not the case, the spherical roller thrust bearing must be preloaded, e.g. by springs. For additional information, contact the SKF application engineering service.

Equivalent dynamic bearing load

Normally a spherical roller thrust bearing is arranged so that runouts in the bearing arrangement do not affect the load distribution in the bearing. For a spherical roller thrust bear-

ing arranged under these conditions, provided $F_r \leq 0,55 F_a$.

$$P = 0,88 (F_a + 1,2 F_r)$$

When runouts in the bearing arrangement affect the load distribution in the spherical roller thrust bearing, provided $F_r \leq 0,55 F_a$

$$P = F_a + 1,2 F_r$$

If $F_r > 0,55 F_a$, the SKF application engineering service should be contacted.

Equivalent static bearing load

$$P_0 = F_a + 2,7 F_r$$

provided $F_r \leq 0,55 F_a$. If $F_r > 0,55 F_a$, the SKF application engineering service should be contacted.

Supplementary designations

The designation suffixes used to identify certain features of SKF spherical roller thrust bearings are explained in the following.

- | | |
|---------------|--|
| E | Optimized internal design and pressed window-type steel cage |
| EF | Optimized internal design and machined steel cage |
| EM | Optimized internal design and machined brass cage |
| N1 | One locating slot in the housing washer |
| N2 | Two locating slots 180° apart in the housing washer |
| VE447 | Shaft washer with three equally spaced threaded holes in one side face to take hoisting tackle |
| VE447E | Shaft washer with three equally spaced threaded holes in one side face to take hoisting tackle and three appropriate eye bolts |
| VE632 | Housing washer with three equally spaced threaded holes in one side face to take hoisting tackle |

Design of associated components

The abutment dimensions d_a and D_a in the product table apply for bearing loads up to approximately $F_a = 0,1 C_0$. Where bearings are to be subjected to heavier loads it may be necessary for both shaft and housing washers to be fully supported ($d_a = d_1$ and $D_a = D_1$) and for radial support to be provided for the housing washer. For additional information, contact the SKF application engineering service.

For E-design bearings with a pressed steel cage, the housing bore must be recessed (→ **fig. 5**) to prevent the cage from rubbing against the housing if the shaft should become misaligned. Recommended guideline values for the diameter of this recess are

- $D + 15$ mm for bearings with outside diameter up to and including 380 mm and
- $D + 20$ mm for larger bearings.

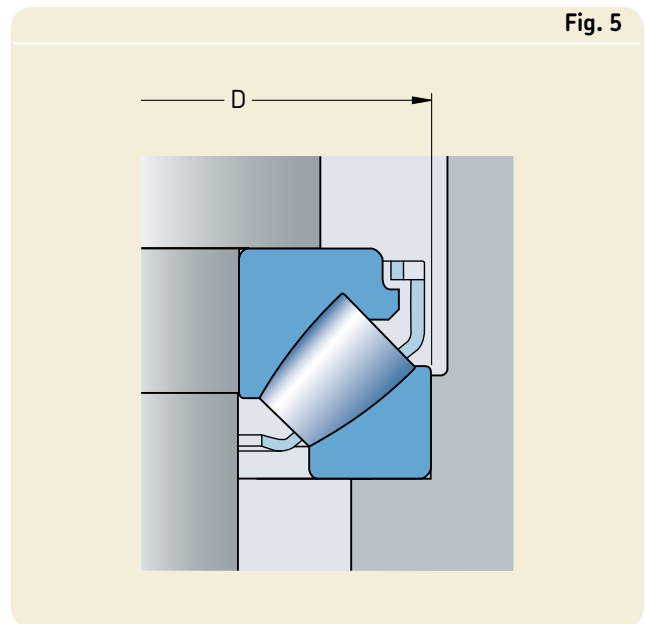

Lubrication

Generally lubrication with oil or grease containing EP additives is recommended for spherical roller thrust bearings.

When lubricating with grease the roller end/flange contacts must be supplied with an adequate amount of lubricant. Depending on the application, this can best be done by completely filling the bearing and its housing with grease, or by regular relubrication.

Because of their internal design, spherical roller thrust bearings have a pumping action that can be taken advantage of, in order to provide circulation of the lubricating oil when

- the shaft is vertical (→ **fig. 6**) or
- the shaft is horizontal (→ **fig. 7**).

The pumping action must be considered when selecting lubricants and seals.

For more detailed information about the lubrication of spherical roller thrust bearings contact the SKF application engineering service.

Fig. 6

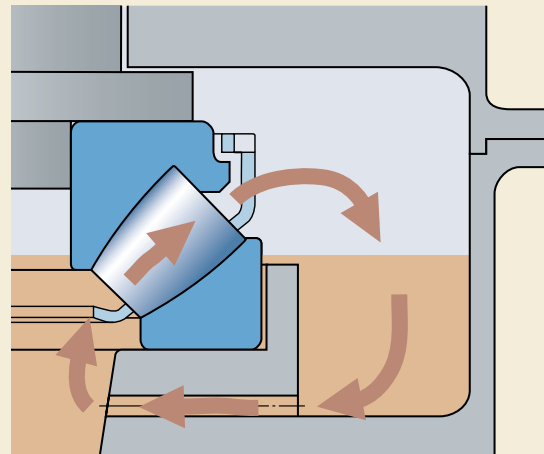
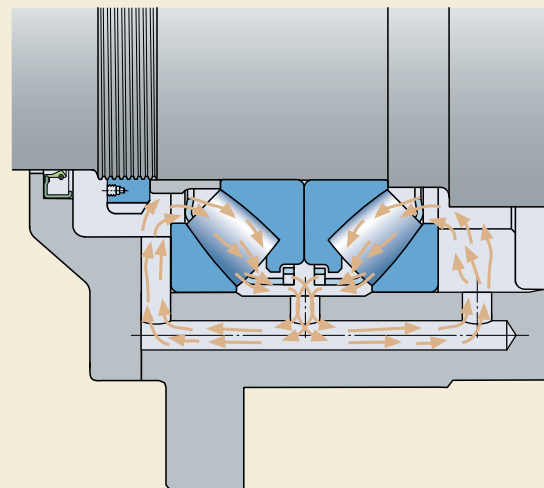

Fig. 7



Mounting

SKF spherical roller thrust bearings are of separable design, i.e. the shaft washer with cage and roller assembly can be mounted separately from the housing washer.

If bearings of earlier design with a machined cage, where the cage-guiding sleeve also served as spacer sleeve, are to be replaced by E-design bearings, a spacer sleeve is needed between the shaft washer and the existing abutment (→ **fig. 8**).

If earlier B-design bearings, which were mounted with a spacer sleeve, are to be replaced, the sleeve must be checked and re-machined if necessary (→ **fig. 9**). The sleeves must be hardened and should have ground end faces; the recommended sleeve outside diameter is provided for each bearing in the product table.

Fig. 8

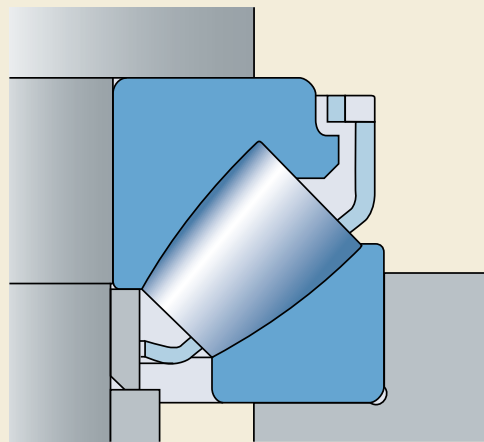
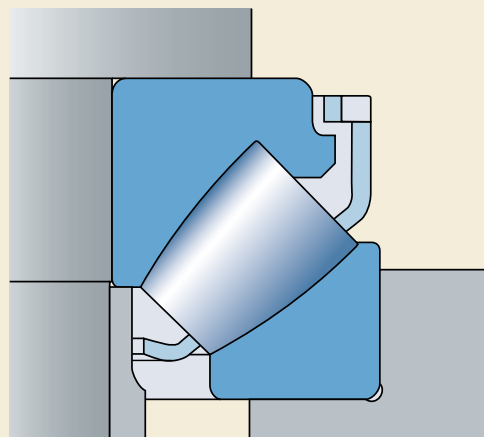
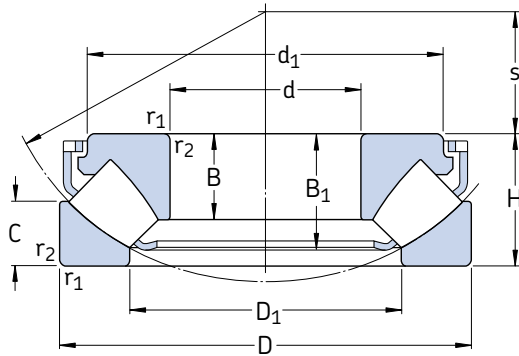

Fig. 9



Spherical roller thrust bearings

d 60 – 170 mm



Principal dimensions			Basic load ratings		Fatigue load limit P_u	Minimum load factor A	Speed ratings		Mass	Designation
d	D	H	C	C_0			Refer- ence speed	Limiting speed		
mm			kN		kN	–	r/min		kg	–
60	130	42	390	915	114	0,080	2 800	5 000	2,20	* 29412 E
65	140	45	455	1 080	137	0,11	2 600	4 800	3,20	* 29413 E
70	150	48	520	1 250	153	0,15	2 400	4 300	3,90	* 29414 E
75	160	51	600	1 430	173	0,19	2 400	4 000	4,70	* 29415 E
80	170	54	670	1 630	193	0,25	2 200	3 800	5,60	* 29416 E
85	150 180	39 58	380 735	1 060 1 800	129 212	0,11 0,31	2 400 2 000	4 000 3 600	2,75 6,75	* 29317 E * 29417 E
90	155 190	39 60	400 815	1 080 2 000	132 232	0,11 0,38	2 400 1 900	4 000 3 400	2,85 7,75	* 29318 E * 29418 E
100	170 210	42 67	465 980	1 290 2 500	156 275	0,16 0,59	2 200 1 700	3 600 3 000	3,65 10,5	* 29320 E * 29420 E
110	190 230	48 73	610 1 180	1 730 3 000	204 325	0,28 0,86	1 900 1 600	3 200 2 800	5,30 13,5	* 29322 E * 29422 E
120	210 250	54 78	765 1 370	2 120 3 450	245 375	0,43 1,1	1 700 1 500	2 800 2 600	7,35 17,5	* 29324 E * 29424 E
130	225 270	58 85	865 1 560	2 500 4 050	280 430	0,59 1,6	1 600 1 300	2 600 2 400	9,00 22,0	* 29326 E * 29426 E
140	240 280	60 85	980 1 630	2 850 4 300	315 455	0,77 1,8	1 500 1 300	2 600 2 400	10,5 23,0	* 29328 E * 29428 E
150	215 250 300	39 60 90	408 1 000 1 860	1 600 2 850 5 100	180 315 520	0,24 0,77 2,5	1 800 1 500 1 200	2 800 2 400 2 200	4,30 11,0 28,0	29230 E * 29330 E * 29430 E
160	270 320	67 95	1 180 2 080	3 450 5 600	375 570	1,1 3	1 300 1 100	2 200 2 000	14,5 33,5	* 29332 E * 29432 E
170	280 340	67 103	1 200 2 360	3 550 6 550	365 640	1,2 4,1	1 300 1 100	2 200 1 900	15,0 44,5	* 29334 E * 29434 E

* SKF Explorer bearing

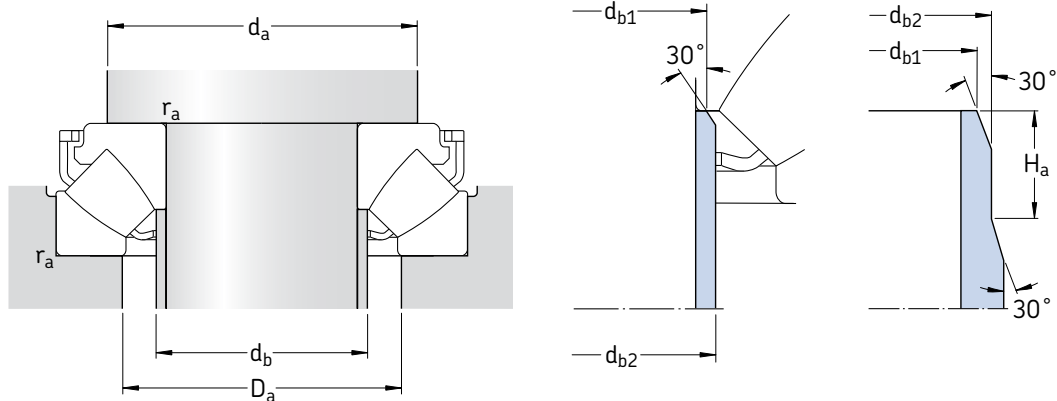
Dimensions
Abutment and fillet dimensions

d	d_1 ~	D_1 ~	B	B_1	C	$r_{1,2}$ min	s	d_a min	d_{b1} max	d_{b2} max	H_a min	D_a max	r_a max
mm								mm					
60	112,2	85,5	27	36,7	21	1,5	38	90	67	67	–	107	1,5
65	120,6	91,5	29,5	39,8	22	2	42	100	72	72	–	117	2
70	129,7	99	31	41	23,8	2	44,8	105	77,5	77,5	–	125	2
75	138,3	105,5	33,5	45,7	24,5	2	47	115	82,5	82,5	–	133	2
80	147,2	112,5	35	48,1	26,5	2,1	50	120	88	88	–	141	2
85	134,8 155,8	109,5 121	24,5 37	33,8 51,1	20 28	1,5 2,1	50 54	115 130	90 94	90 94	–	129 151	1,5 2
90	138,6 164,6	115 127,5	24,5 39	34,5 54	19,5 28,5	1,5 2,1	53 56	120 135	95 99	95 99	–	134 158	1,5 2
100	152,3 182,2	127,5 141,5	26,2 43	36,3 57,3	20,5 32	1,5 3	58 62	130 150	107 110	107 110	–	147 175	1,5 2,5
110	171,1 199,4	140 155,5	30,3 47	41,7 64,7	24,8 34,7	2 3	63,8 69	145 165	117 120,5	117 129	–	164 193	2 2,5
120	188,1 216,8	154 171	34 50,5	48,2 70,3	27 36,5	2,1 4	70 74	160 180	128 132	128 142	–	181 209	2 3
130	203,4 234,4	165,5 184,5	36,7 54	50,6 76	30,1 40,9	2,1 4	75,6 81	175 195	138 142,5	143 153	–	194 227	2 3
140	216,1 245,4	177 194,5	38,5 54	54 75,6	30 41	2,1 4	82 86	185 205	148 153	154 162	–	208 236	2 3
150	200,4 223,9 262,9	176 190 207,5	24 38 58	34,3 54,9 80,8	20,5 28 43,4	1,5 2,1 4	82 87 92	180 195 220	154 158 163	154 163 175	14	193 219 253	1,5 2 3
160	243,5 279,3	203 223,5	42 60,5	60 84,3	33 45,5	3 5	92 99	210 235	169 175	176 189	–	235 270	2,5 4
170	251,2 297,7	215 236	42,2 65,5	61 91,2	30,5 50	3 5	96 104	220 250	178 185	188 199	–	245 286	2,5 4

Spherical roller thrust bearings

d 180 – 340 mm

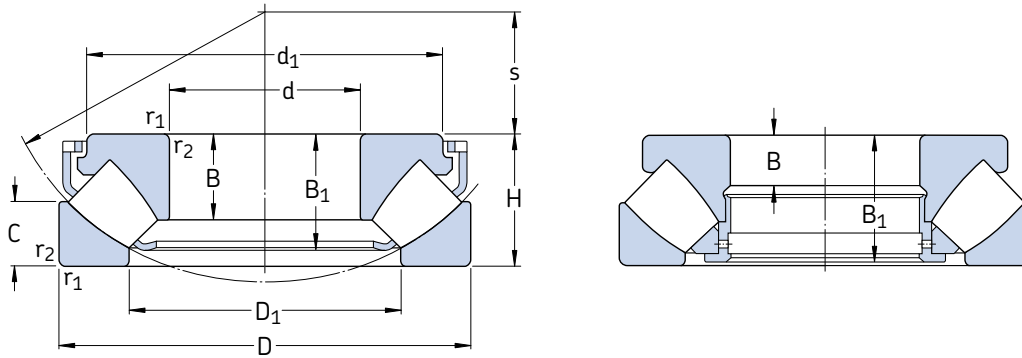

E design

Principal dimensions			Basic load ratings		Fatigue load limit P_u	Minimum load factor A	Speed ratings		Mass	Designation
d	D	H	C	C_0			Refer- ence speed	Limiting speed		
mm			kN		kN	–	r/min	kg	–	
180	250	42	495	2 040	212	0,40	1 600	2 600	5,80	29236 E
	300	73	1 430	4 300	440	1,8	1 200	2 000	19,5	* 29336 E
	360	109	2 600	7 350	710	5,1	1 000	1 800	52,5	* 29436 E
190	320	78	1 630	4 750	490	2,1	1 100	1 900	23,5	* 29338 E
	380	115	2 850	8 000	765	6,1	950	1 700	60,5	* 29438 E
200	280	48	656	2 650	285	0,67	1 400	2 200	9,30	29240 E
	340	85	1 860	5 500	550	2,9	1 000	1 700	29,5	* 29340 E
	400	122	3 200	9 000	850	7,7	850	1 600	72,0	* 29440 E
220	300	48	690	3 000	310	0,86	1 300	2 200	10,0	29244 E
	360	85	2 000	6 300	610	3,8	1 000	1 700	33,5	* 29344 E
	420	122	3 350	9 650	900	8,8	850	1 500	75,0	* 29444 E
240	340	60	799	3 450	335	1,1	1 100	1 800	16,5	29248
	380	85	2 040	6 550	630	4,1	1 000	1 600	35,5	* 29348 E
	440	122	3 400	10 200	930	9,9	850	1 500	80,0	* 29448 E
260	360	60	817	3 650	345	1,3	1 100	1 700	18,5	29252
	420	95	2 550	8 300	780	6,5	850	1 400	49,0	* 29352 E
	480	132	4 050	12 900	1 080	16	750	1 300	105	* 29452 E
280	380	60	863	4 000	375	1,5	1 000	1 700	19,5	29256
	440	95	2 550	8 650	800	7,1	850	1 400	53,0	* 29356 E
	520	145	4 900	15 300	1 320	22	670	1 200	135	* 29456 E
300	420	73	1 070	4 800	465	2,2	900	1 400	30,5	29260
	480	109	3 100	10 600	930	11	750	1 200	75,0	* 29360 E
	540	145	4 310	16 600	1 340	26	600	1 200	140	29460 E
320	440	73	1 110	5 100	465	2,5	850	1 400	33,0	29264
	500	109	3 350	11 200	1 000	12	750	1 200	78,0	* 29364 E
	580	155	4 950	19 000	1 530	34	560	1 100	175	29464 E
340	460	73	1 130	5 400	480	2,8	850	1 300	33,5	29268
	540	122	2 710	11 000	950	11	600	1 100	105	29368
	620	170	5 750	22 400	1 760	48	500	1 000	220	29468 E

* SKF Explorer bearing

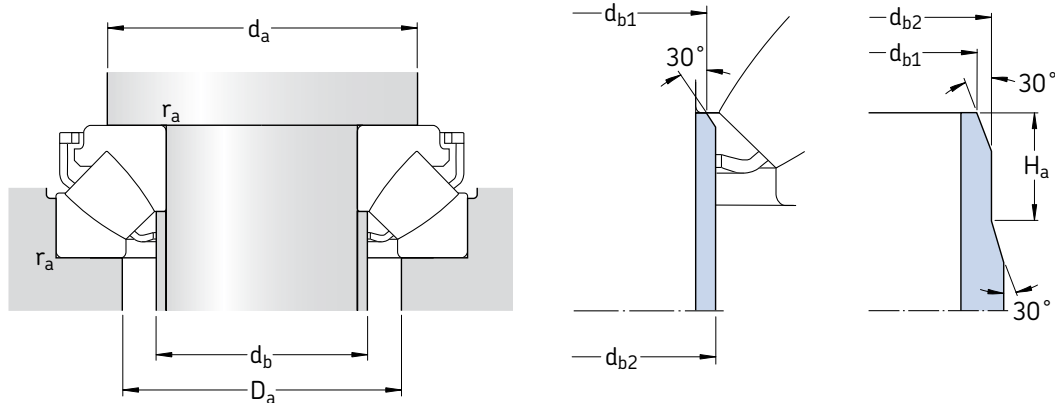

Dimensions

Abutment and fillet dimensions

d	d ₁	D ₁	B	B ₁	C	r _{1,2} min	s	d _a min	d _{b1} max	d _{b2} max	H _a min	D _a max	r _a max
mm								mm					
180	234,4	208	26	36,9	22	1,5	97	210	187	187	14	226	1,5
	270	227	46	66,2	35,5	3	103	235	189	195	-	262	2,5
	315,9	250	69,5	96,4	53	5	110	265	196	210	-	304	4
190	285,6	243,5	49	71,3	36	4	110	250	200	211	-	280	3
	332,9	264,5	73	101	55,5	5	117	280	207	223	-	321	4
200	260,5	232,5	30	43,4	24	2	108	235	206	207	17	253	2
	304,3	257	53,5	76,7	40	4	116	265	211	224	-	297	3
	350,7	277,5	77	107,1	59,4	5	122	295	217,5	234	-	337	4
220	280,5	251,5	30	43,4	24,5	2	117	255	224,5	227	17	271	2
	326,3	273,5	55	77,7	41	4	125	285	229	240	-	316	3
	371,6	300	77	107,4	58,5	6	132	315	238	254	-	358	5
240	330	283	19	57	30	2,1	130	290	-	-	-	308	2
	345,1	295,5	54	77,8	40,5	4	135	305	249	259	-	336	3
	391,6	322	76	107,1	59	6	142	335	258	276	-	378	5
260	350	302	19	57	30	2,1	139	310	-	-	-	326	2
	382,2	324	61	86,6	46	5	148	335	273	286	-	370	4
	427,9	346	86	119	63	6	154	365	278	296	-	412	5
280	370	323	19	57	30,5	2,1	150	325	-	-	-	347	2
	401	343	62	86,7	45,5	5	158	355	293	305	-	390	4
	464,3	372	95	129,9	70	6	166	395	300	320	-	446	5
300	405	353	21	69	38	3	162	360	-	-	-	380	2,5
	434,1	372	70	98,9	51	5	168	385	313	329	-	423	4
	485	392	95	130,3	70,5	6	175	415	319	340	-	465	5
320	430	372	21	69	38	3	172	380	-	-	-	400	2,5
	454,5	391	68	97,8	53	5	180	405	332	347	-	442	4
	520,3	422	102	139,4	74,5	7,5	191	450	344	367	-	500	6
340	445	395	21	69	37,5	3	183	400	-	-	-	422	2,5
	520	428	40,6	117	59,5	5	192	440	-	-	-	479	4
	557,9	445	112	151,4	84	7,5	201	475	363	386	-	530	6

Spherical roller thrust bearings
d 360 – 560 mm

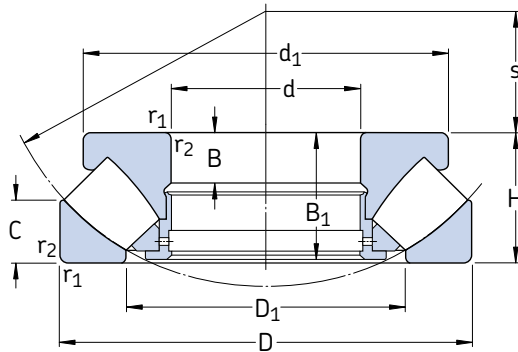

Principal dimensions			Basic load ratings		Fatigue load limit P_u	Minimum load factor A	Speed ratings		Mass	Designation
d	D	H	C	C_0			Refer- ence speed	Limiting speed		
mm			kN		kN	–	r/min	kg	–	
360	500	85	1 460	6 800	585	4,4	750	1 200	52,0	29272
	560	122	2 760	11 600	980	13	600	1 100	110	29372
	640	170	5 350	21 200	1 630	43	500	950	230	29472 EM
380	520	85	1 580	7 650	655	5,6	700	1 100	53,0	29276
	600	132	3 340	14 000	1 160	19	530	1 000	140	29376
	670	175	5 870	24 000	1 860	55	480	900	260	29476 EM
400	540	85	1 610	8 000	695	6,1	700	1 100	55,5	29280
	620	132	3 450	14 600	1 200	20	530	950	150	29380
	710	185	6 560	26 500	1 960	67	450	850	310	29480 EM
420	580	95	1 990	9 800	815	9,1	630	1 000	75,5	29284
	650	140	3 740	16 000	1 290	24	500	900	170	29384
	730	185	6 730	27 500	2 080	72	430	850	325	29484 EM
440	600	95	2 070	10 400	850	10	630	1 000	78,0	29288
	680	145	4 490	19 300	1 560	35	480	850	180	29388 EM
	780	206	7 820	32 000	2 320	87	380	750	410	29488 EM
460	620	95	2 070	10 600	865	11	600	950	81,0	29292
	710	150	4 310	19 000	1 500	34	450	800	215	29392
	800	206	7 990	33 500	2 450	110	380	750	425	29492 EM
480	650	103	2 350	11 800	950	13	560	900	98,0	29296
	730	150	4 370	19 600	1 530	36	450	800	220	29396
	850	224	9 550	39 000	2 800	140	340	670	550	29496 EM
500	670	103	2 390	12 500	1 000	15	560	900	100	292/500
	750	150	4 490	20 400	1 560	40	430	800	235	293/500
	870	224	9 370	40 000	2 850	150	340	670	560	294/500 EM
530	710	109	3 110	15 300	1 220	22	530	850	115	292/530 EM
	800	160	5 230	23 600	1 800	53	400	750	270	293/530
	920	236	10 500	44 000	3 100	180	320	630	650	294/530 EM
560	750	115	2 990	16 000	1 220	24	480	800	140	292/560
	980	250	12 000	51 000	3 550	250	300	560	810	294/560 EM

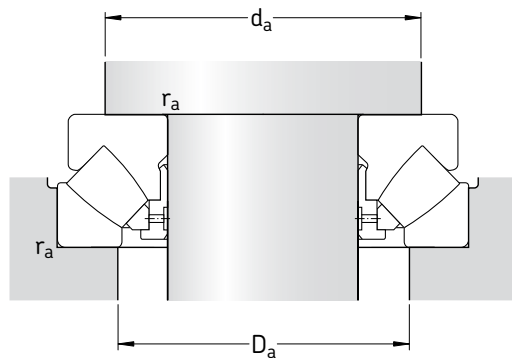

Dimensions								Abutment and fillet dimensions		
d	d ₁	D ₁	B	B ₁	C	r _{1,2}	s	d _a	D _a	r _a
								min	max	max
mm								mm		
360	485	423	25	81	44	4	194,5	430	453	3
	540	448	40,5	117	59,5	5	202	460	500	4
	580	474	63	164	83,5	7,5	210	495	550	6
380	505	441	27	81	42	4	202	450	473	3
	580	477	45	127	63,5	6	216	495	535	5
	610	494	67	168	87,5	7,5	222	525	580	6
400	526	460	27	81	42,2	4	212	470	493	3
	596	494	43	127	64	6	225	510	550	5
	645	525	69	178	89,5	7,5	234	550	615	6
420	564	489	30	91	46	5	225	500	525	4
	626	520	49	135	67,5	6	235	535	580	5
	665	545	70	178	90,5	7,5	244	575	635	6
440	585	508	30	91	46,5	5	235	520	545	4
	626	540	49	140	70,5	6	249	560	605	5
	710	577	77	199	101	9,5	257	605	675	8
460	605	530	30	91	46	5	245	540	565	4
	685	567	50	144	72,5	6	257	585	630	5
	730	596	77	199	101,5	9,5	268	630	695	8
480	635	556	33	99	53,5	5	259	570	595	4
	705	591	50	144	73,5	6	270	610	655	5
	770	625	88	216	108	9,5	280	660	735	8
500	654	574	33	99	53,5	5	268	585	615	4
	725	611	50	144	74	6	280	630	675	5
	795	648	86	216	110	9,5	290	685	755	8
530	675	608	32	105	56	5	285	620	655	4
	772	648	53	154	76	7,5	295	670	715	6
	840	686	89	228	116	9,5	308	725	800	8
560	732	644	37	111	61	5	302	655	685	4
	890	727	99	241	122	12	328	770	850	10

Spherical roller thrust bearings
d 600 – 1 600 mm

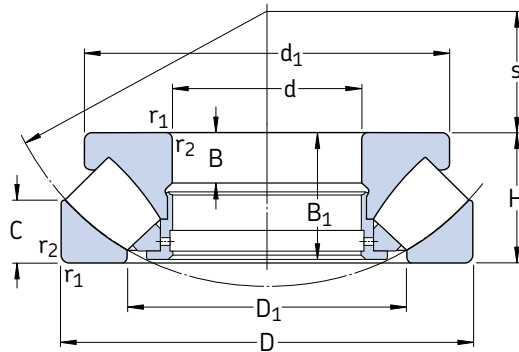

Principal dimensions			Basic load ratings		Fatigue load limit P_u	Minimum load factor A	Speed ratings		Mass	Designation
d	D	H	dynamic	static			Refer- ence speed	Limiting speed		
mm			kN		kN	–	r/min	kg	–	
600	800	122	3 740	18 600	1 460	33	450	700	170	292/600 EM
	900	180	7 530	34 500	2 600	110	340	630	405	293/600
	1 030	258	13 100	56 000	4 000	300	280	530	845	294/600 EM
630	850	132	4 770	23 600	1 800	53	400	670	210	292/630 EM
	950	190	8 450	38 000	2 900	140	320	600	485	293/630 EM
	1 090	280	14 400	62 000	4 150	370	260	500	1 040	294/630 EM
670	900	140	4 200	22 800	1 660	49	380	630	255	292/670
	1 150	290	15 400	68 000	4 500	440	240	450	1 210	294/670 EM
710	1 060	212	9 950	45 500	3 400	200	280	500	660	293/710 EM
	1 220	308	17 600	76 500	5 000	560	220	430	1 500	294/710 EF
750	1 000	150	6 100	31 000	2 320	91	340	560	325	292/750 EM
	1 120	224	9 370	45 000	3 050	190	260	480	770	293/750
	1 280	315	18 700	85 000	5 500	690	200	400	1 650	294/750 EF
800	1 060	155	6 560	34 500	2 550	110	320	530	380	292/800 EM
	1 180	230	9 950	49 000	3 250	230	240	450	865	293/800
	1 360	335	20 200	93 000	5 850	820	190	360	2 025	294/800 EF
850	1 120	160	6 730	36 000	2 550	120	300	500	425	292/850 EM
	1 440	354	23 900	108 000	7 100	1 100	170	340	2 390	294/850 EF
900	1 520	372	26 700	122 000	7 200	1 400	160	300	2 650	294/900 EF
950	1 250	180	8 280	45 500	3 100	200	260	430	600	292/950 EM
	1 600	390	28 200	132 000	7 800	1 700	140	280	3 065	294/950 EF
1 000	1 670	402	31 100	140 000	8 650	1 900	130	260	3 380	294/1000 EF
1 060	1 400	206	10 500	58 500	3 750	330	220	360	860	292/1060 EF
	1 770	426	33 400	156 000	8 500	2 300	120	240	4 280	294/1060 EF
1 180	1 520	206	10 900	64 000	3 750	390	220	340	950	292/1180 EF
1 250	1 800	330	24 800	129 000	7 500	1 600	130	240	2 770	293/1250 EF
1 600	2 280	408	36 800	200 000	11 800	3 800	90	160	5 375	293/1600 EF

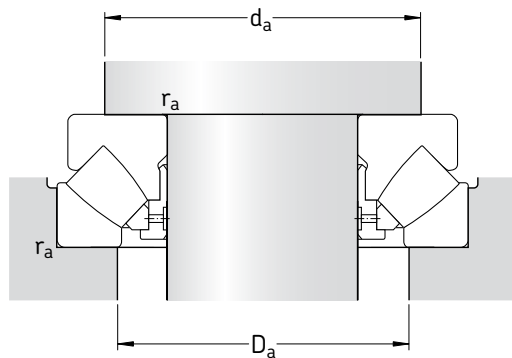

Dimensions								Abutment and fillet dimensions		
d	d_1	D_1	B	B_1	C	$r_{1,2}$ min	s	d_a min	D_a max	r_a max
mm								mm		
600	760	688	39	117	60	5	321	700	735	4
	840	720	65	174	89	7,5	340	755	810	6
	940	769	99	249	128	12	349	815	900	10
630	810	723	50	127	62	6	338	740	780	5
	880	761	68	183	92	9,5	359	795	860	8
	995	815	107	270	137	12	365	860	950	10
670	880	773	45	135	73	6	361	790	825	5
	1 045	864	110	280	141	15	387	905	1 000	12
710	985	855	74	205	103	9,5	404	890	960	8
	1 110	917	117	298	149	15	415	965	1 070	12
750	950	858	50	144	74	6	409	880	925	5
	1 086	910	76	216	109	9,5	415	935	1 000	8
	1 170	964	121	305	153	15	436	1 015	1 120	12
800	1 010	911	52	149	77	7,5	434	935	980	6
	1 146	965	77	222	111	9,5	440	995	1 060	8
	1 250	1 034	123	324	165	15	462	1 080	1 185	12
850	1 060	967	47	154	82	7,5	455	980	1 030	6
	1 315	1 077	142	342	172	15	507	1 160	1 270	12
900	1 394	1 137	147	360	186	15	518	1 215	1 320	12
950	1 185	1 081	58	174	88	7,5	507	1 095	1 155	6
	1 470	1 209	153	377	191	15	546	1 275	1 400	12
1 000	1 531	1 270	155	389	190	15	599	1 350	1 490	12
1 060	1 325	1 211	66	199	100	9,5	566	1 225	1 290	8
	1 615	1 349	192	412	207	15	610	1 410	1 555	12
1 180	1 450	1 331	83	199	101	9,5	625	1 345	1 410	8
1 250	1 685	1 474	148	319	161	12	698	1 540	1 640	10
1 600	2 130	1 885	166	395	195	19	894	1 955	2 090	15



Engineering products

Hybrid bearings	895
INSOCOAT® bearings.....	911
Bearings and bearing units for high temperatures.....	921
NoWear® bearings	943
Bearings and bearing units with Solid Oil	949





Hybrid bearings

Hybrid bearings	896
SKF hybrid deep groove ball bearings	897
Sealed and greased-for-life bearings	897
Open design bearings.....	898
Other SKF hybrid bearings	898
Hybrid high-precision bearings	898
Hybrid ball and roller bearings, hybrid bearing units	898
Hybrid bearings with special steel rings and coatings.....	898
Bearing data – general	899
Dimensions, tolerances, internal clearance	899
Misalignment.....	899
Cages.....	900
Minimum load.....	900
Axial preloading	900
Axial load carrying capacity.....	900
Equivalent dynamic bearing load.....	901
Equivalent static bearing load.....	901
Speed capability.....	901
Silicon nitride properties.....	901
Electrical properties	901
Supplementary designations.....	902
Selection of bearing size	903
Lubrication	903
Product tables	904
Sealed and greased-for-life hybrid deep groove ball bearings.....	904
Hybrid deep groove ball bearings	908

Hybrid bearings

Hybrid bearings have rings of bearing steel and rolling elements of bearing grade silicon nitride (Si_3N_4). In addition to being excellent electric insulators, hybrid bearings have a higher speed capability and will provide longer service life than all-steel bearings in most applications.

The very good electrical insulating property is one of the essential features of the silicon nitride. This protects the rings from electric current damage and thus increases bearing service life.

The density of silicon nitride is only 40 % of the density of bearing steel. Thus the rolling elements weigh less and have lower inertia. This means less cage stresses during rapid starts and stops and also significantly lower friction at high speeds as explained in the section “Friction” on **page 102**. Lower friction means cooler running and longer lubricant service life. Hybrid bearings are thus suitable for high rotational speeds.

Under insufficient lubrication conditions there is no smearing between silicon nitride and steel. This enables hybrid bearings to last much longer in applications operating under severe dynamic conditions or lubrication conditions with low operating viscosity ($\kappa < 1$). For hybrid bearings it is common to apply $\kappa = 1$ for running conditions with $\kappa < 1$ to estimate life under such conditions. Hybrid bearings may perform well, when lubricated with ultra thin film forming media, such as refrigerants, enabling oil-free designs but care needs to be taken in design and material selection. In such cases it is recommended to consult the SKF application engineering service before deciding upon design and ordering.

Silicon nitride has a higher hardness and higher modulus of elasticity than steel, resulting in increased bearing stiffness and longer bearing service life in contaminated environments.

Silicon nitride rolling elements have a lower thermal expansion than steel rolling elements of similar size. This means less sensitivity to temperature gradients within the bearing and more accurate preload control. When designing bearing arrangements for very low temperature and as to estimate reductions in bearing clearance of hybrid bearings, please contact the SKF application engineering service.

Fig. 1

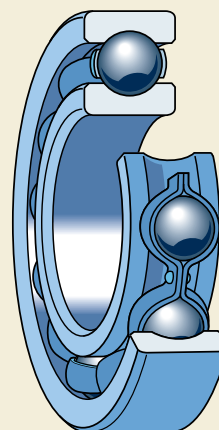

SKF hybrid deep groove ball bearings

The SKF standard range of hybrid bearings essentially comprises hybrid single row deep groove ball bearings (→ **fig. 1**). The reason for it is clear: deep groove ball bearings are the most widely used bearing type, especially in electric motors, and are very useful for simple designs utilizing greased-for-life bearings. Deep raceway grooves and the close conformity between the raceways and the balls enable the accommodation of radial loads as well as of axial loads in both directions.

SKF hybrid deep groove ball bearings are available from 5 up to 110 mm bore diameter. They meet most application needs. Larger bearings can also be manufactured by SKF on request.

Bearings up to 45 mm bore diameter, for example, are most suitable for electrical motors in the power range of 0,15 up to 15 kW as well as generators, power tools and high-speed drives.

There is a wide application field for hybrid deep groove ball bearings, consequently SKF produces

- sealed and greased-for-life bearings
- open design bearings.

Sealed and greased-for-life bearings

Sealed and greased-for-life SKF hybrid deep groove ball bearings (→ **fig. 2**) are protected on both sides, either by

- a low-friction seal of the RSL design (**a**) fitted to bearings with an outside diameter up to 25 mm, designation suffix 2RSL
- a low-friction seal of the RSL design (**b**) fitted to bearings with an outside diameter over 25 mm and up to and inclusive 52 mm, designation suffix 2RSL
- a low-friction seal of the RZ design (**c**) fitted to bearings with an outside diameter above 52 mm, designation suffix 2RZ
- a contact seal of the RS1 design (**d**), designation suffix 2RS1.

Details about the suitability of the different seals for various operating conditions can be found in the section “Deep groove ball bearings”, starting on **page 287**.

The seals are made of acrylonitrile-butadiene rubber (NBR) with sheet steel reinforcement. The permissible operating temperature range for these seals is -40 to $+100$ °C and up to $+120$ °C for brief periods.

Sealed bearings are filled as standard with a premium quality grease, synthetic ester oil based using polyurea thickener, bearing designation suffix WT. It has excellent lubrication properties in the temperature range from about $+70$ to $+120$ °C, offers extremely long life unattainable with other sealed and greased-for-life bearing designs and fits the needs of electrical

Fig. 2

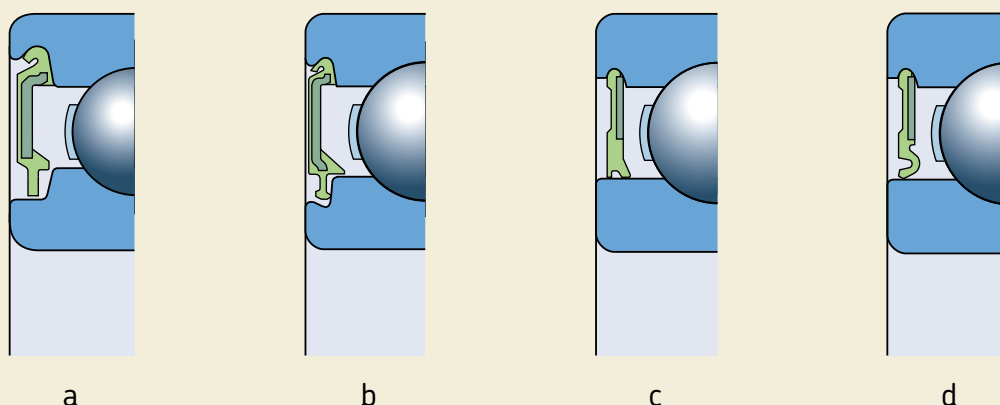

Hybrid bearings

machinery. The most important properties of the WT grease are listed in **table 1**.

Regarding the suitability for high temperatures, the permissible temperature ranges of the cage and seals have to be taken into consideration. For SKF hybrid bearings with seals of fluoro rubber, which withstand temperatures up to 180 °C please contact the SKF application engineering service.

Open design bearings

In addition to sealed and greased-for-life bearings larger SKF hybrid deep groove ball bearings are also available in open basic design without seals. If smaller open design bearings are required and the quantity is small, SKF recommends ordering sealed hybrid bearings and removing the seals, which can be done quite simply.

Other SKF hybrid bearings

Hybrid high-precision bearings

The SKF product range also includes a selection of

- hybrid high-precision angular contact ball bearings
- hybrid high-precision cylindrical roller bearings
- hybrid high-precision angular contact thrust ball bearings, single and double direction.

Detailed information about these hybrid bearings can be found in the SKF catalogue “High-precision bearings”.

In addition, hybrid single or double row angular contact ball bearings and hybrid four-point contact ball bearings can be manufactured to special order. In such cases the SKF application engineering service should be contacted for further information.

Hybrid ball and roller bearings, hybrid bearing units

SKF also designs and manufactures a variety of other hybrid bearings in standard sizes on special order for certain size ranges including

- angular contact ball bearings
- cylindrical roller bearings
- bearing units.

Such designs enable a combination of optimal performance, simplicity in handling and economy. For more information, please contact the SKF application engineering service.

Hybrid bearings with special steel rings and coatings

SKF hybrid bearings are made as standard of the same steel as the equivalent all-steel bearing. The standard stabilization temperatures are 120 °C for deep groove ball bearings and 150 °C for angular contact ball bearings. For continuous operation above these temperatures it is recommended to use bearings with rings that are dimensionally stabilized for use at higher operating temperatures e.g.

Table 1

Properties of WT grease	
Properties	WT grease
DIN 51825 code	K2P-40
Thickener	Polyurea (Di-urea)
Base oil type	Synthetic ester
NLGI consistency class	2–3
Temperature range, °C ¹⁾	–40 to +160
Base oil viscosity, mm ² /s at 40 °C	70
at 100 °C	9,4

¹⁾ For safe operating temperature, → section “Temperature range – the SKF traffic light concept”, starting on page 232

- up to +150 °C, suffix S0
- up to +200 °C, suffix S1.

Hybrid deep groove ball bearings stabilized to S0 or S1 etc. are normally not stocked.

On request hybrid bearings can be manufactured with through-hardened rings of stainless bearing steels with good corrosion, wear and oxidation resistance and good high temperature properties. Such bearings can operate at temperatures up to 300 °C.

For custom-made hybrid bearings with rings of special stainless steels for cryogenic temperatures or of high temperature tool steels please contact the SKF application engineering service.

The rings may be coated for corrosion protection e.g. with zinc chromate or thin dense chromium. Low friction coatings of molybdenum base can be applied for vacuum and gas applications.

Bearing data – general

Dimensions, tolerances, internal clearance

SKF hybrid deep groove ball bearings are standardized bearings and are manufactured as standard with

- boundary dimensions to ISO 15:1998
- Normal tolerances to ISO 492:2002
- C3 radial internal clearance to ISO 5753:1991 (→ **table 2**).

Misalignment

Hybrid deep groove ball bearings have only limited ability to accommodate misalignment. The permissible angular misalignment between inner and outer rings, which will not produce inadmissibly high additional stresses in the bearing, depends on

- the radial internal clearance of the bearing in operation
- the bearing size
- the forces and moments acting on the bearing.

Depending on the various influences of the factors, the permissible angular misalignment lies between 2 and 10 minutes of arc. Any misalignment will result in increased bearing noise and reduced bearing service life.

Table 2

Internal clearance			
Bearing bore diameter		Radial internal clearance	
d over	incl.	C3 min	max
mm		µm	
10	10	8	23
18	18	11	25
30	30	13	28
40	40	15	33
50	50	18	36
65	65	23	43
80	80	25	51
100	100	30	58
120	120	36	66

Hybrid bearings

Cages

Depending on the bearing size, SKF hybrid deep groove ball bearings are fitted with

- an injection moulded snap-type cage of glass fibre reinforced polyamide 6,6, ball centred, designation suffix TN9 (→ **fig. 3a**)
- a riveted cage of pressed steel, ball centred, no designation suffix (→ **fig. 3b**).

Hybrid bearings with a cage of glass fibre reinforced polyamide 6,6 can be operated at temperatures up to +120 °C.

Minimum load

In order to provide satisfactory operation, hybrid deep groove ball bearings, like the standard bearings, must always be subjected to a given minimum load. Please refer to the section "Minimum load" of standard deep groove ball bearings on **page 298**.

However, hybrid bearings are generally more resistant to skidding and smearing damages of raceways caused by too light loads. This makes hybrid bearings a good alternative for bearing arrangements subjected to variable load cycles that include light loads.

Axial preloading

In order to provide low noise and good high-speed operation it is normal to apply an axial preload to a bearing arrangement comprising two hybrid deep groove ball bearings. A particular simple method to apply the axial preload is by using spring washers, as described in the section "Preloading by springs", starting on **page 216**. The recommended axial preloads can be calculated as provided in this section. For additional information please refer to the section "Bearing preload", starting on **page 206**.

Axial load carrying capacity

If hybrid deep groove ball bearings are subjected to purely axial load, this axial load should generally not exceed the value of $0,5 C_0$. Small bearings (bore diameter up to approx. 12 mm) and bearings in the light Diameter Series 0 should not be subjected to an axial load greater than $0,25 C_0$. Excessive axial loads can lead to a considerable reduction in bearing service life.

Fig. 3

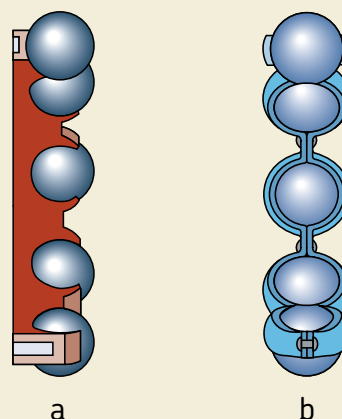

Equivalent dynamic bearing load

$$P = F_r \quad \text{when } F_a/F_r \leq e$$

$$P = 0,46 F_r + Y F_a \quad \text{when } F_a/F_r > e$$

The factors e and Y depend on the relationship $f_0 F_a/C_0$, where f_0 is a calculation factor (\rightarrow product tables), F_a the axial component of the load and C_0 the basic static load rating.

In addition, the factors are influenced by the magnitude of the radial internal clearance. For bearings with C3 internal clearance mounted with the usual fits as listed in **tables 2, 4** and **5** on **pages 169** to **171**, the values for e and Y are listed in **table 3** below.

Equivalent static bearing load

$$P_0 = 0,6 F_r + 0,5 F_a$$

If $P_0 < F_r$, $P_0 = F_r$ should be used.

Speed capability

Hybrid deep groove ball bearings fitted with a polymeric cage can be operated at speeds in excess of the ratings given for all-steel bearings. The limiting speeds listed in the product tables are valid for bearings with the standard cage, seal and grease according to the bearing designation. Hybrid bearings fitted with a cage of polyetheretherketone (PEEK) can be operated at higher speeds and temperatures. For more information please contact the SKF application engineering service.

The values for “Reference speed” shown with the sealed bearings are valid for open basic design bearings and demonstrate the speed capability of these bearings. For sealed bearings the values listed for “Limiting speed” should not be exceeded.

Hybrid bearings perform excellently under vibrating or oscillating conditions. It is therefore not usually necessary to apply special greases or preloads for these conditions.

Silicon nitride properties

The properties of the bearing grade silicon nitride (Si_3N_4) are presented in the section “Materials for rolling bearings”, starting on **page 138**.

Electrical properties

Hybrid bearings provide effective protection against electric arc damage to the grease and raceways caused by both AC and DC currents. The impedance for a hybrid bearing is high, even for very high frequencies, providing extremely good protection against high frequency current and peaks through the ball/raceway contacts. For small hybrid bearings equipped with a sheet steel reinforced contact seal of acrylonitrile-butadiene rubber (NBR), the voltage level when the first arcing occurs through the seal/bearing contact is beyond 2,5 kV DC. For additional information please contact the SKF application engineering service.

Table 3

Calculation factors for hybrid deep groove ball bearings with C3 radial internal clearance

$f_0 F_a/C_0$	e	Y
0,172	0,29	1,88
0,345	0,32	1,71
0,689	0,36	1,52
1,03	0,38	1,41
1,38	0,40	1,34
2,07	0,44	1,23
3,45	0,49	1,10
5,17	0,54	1,01
6,89	0,54	1,00

Intermediate values are obtained by linear interpolation

Hybrid bearings

Supplementary designations

The designation suffixes used to identify certain features of SKF hybrid deep groove ball bearings are explained in the following.

C3	Radial internal clearance greater than Normal
F1	Grease filling grade: 10–15 % of the free space in the bearing
HC5	Rolling elements of silicon nitride
2RS1	Sheet steel reinforced contact seal of acrylonitrile-butadiene rubber (NBR) on both sides of the bearing
2RSH2	Sheet steel reinforced contact seal of fluoro rubber (FKM) on both sides of the bearing
2RSL	Sheet steel reinforced low-friction seal of acrylonitrile-butadiene rubber (NBR) on both sides of the bearing
2RZ	Sheet steel reinforced low-friction seal of acrylonitrile-butadiene rubber (NBR) on both sides of the bearing
TNH	Injection moulded snap-type cage of polyetheretherketone (PEEK), ball centred
TN9	Injection moulded snap-type cage of glass fibre reinforced polyamide 6,6, ball centred
WT	Grease with polyurea thickener of consistency 2–3 to the NLGI Scale for a temperature range –40 to +160 °C (normal filling grade)

Selection of bearing size

When selecting the necessary bearing size of hybrid deep groove ball bearings please follow the procedure for all-steel bearings in the section “Selection of bearing size”, starting on **page 49**. Due to the higher modulus of elasticity of ceramic balls the static safety factor s_0 should be increased by

$$s_{0 \text{ hybrid}} = 1,1 s_{0 \text{ all-steel}}$$

The recommended values of s_0 for all-steel bearings can be found in **table 10** on **page 77**.

Lubrication

Most of the SKF hybrid deep groove ball bearings are sealed and greased-for-life. In the case of open bearings and grease lubrication SKF recommends the SKF grease LGHP 2 for electrical motors. For very high-speed applications at temperatures below +70 °C the use of either SKF grease LGLC 2 or SKF grease LGLT 2 is recommended. More about the SKF greases can be found in the section “Lubrication”, starting on **page 229**.

Applications requiring long service life at extremely high speeds have to be oil-lubricated. The two recommended lubrication methods in this case are

- oil jet lubrication
- oil-air lubrication.

Oil-air lubrication, e.g. by the VOGEL OLA oil + air systems (→ **fig. 4**), enables reliable lubrication to be achieved with extremely small quantities of oil, which lowers the operating temperatures, enables higher speeds and reduces oil emission to the environment.

For more information about the design of oil-air lubrication arrangements, please refer to the VOGEL publication 1-5012-3 “Oil + Air Systems”, or please visit www.vogelag.com.

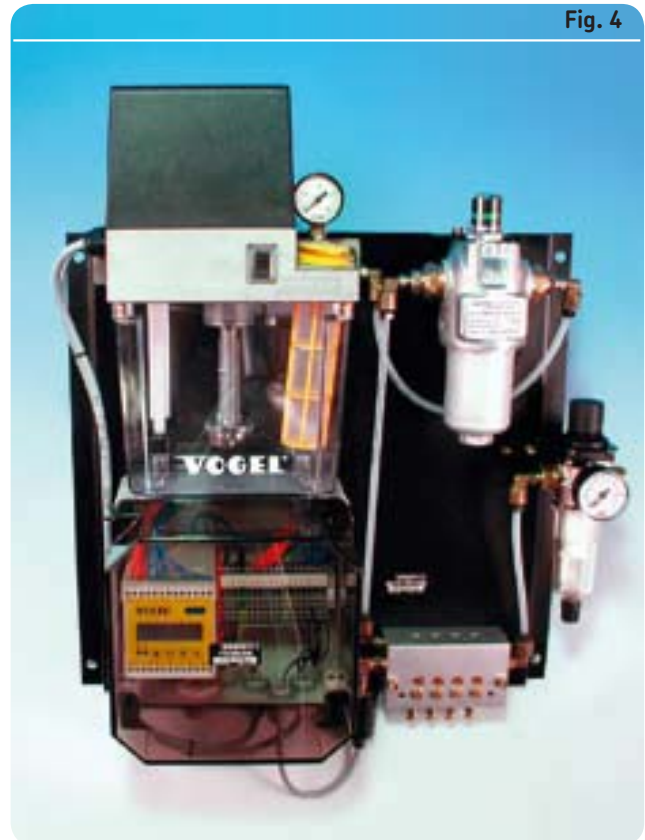
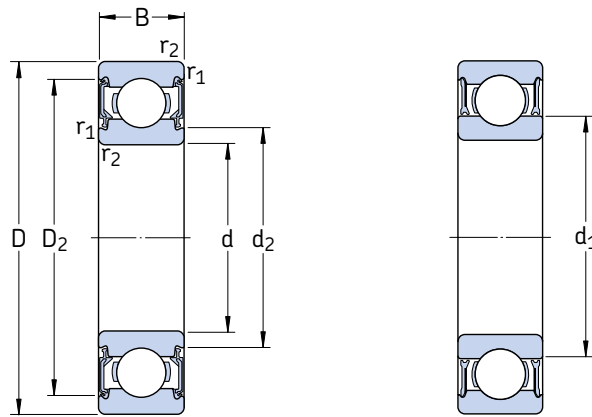

Fig. 4

**Sealed and greased-for-life
hybrid deep groove ball bearings**
d 5 – 45 mm



2RSL

2RZ

Principal dimensions			Basic load ratings		Fatigue load limit P_u	Speed ratings		Mass	Designation
d	D	B	dynamic C	static C_0		Reference speed	Limiting speed		
mm			kN		kN	r/min		kg	–
5	16	5	1,14	0,38	0,016	130 000	85 000	0,0050	625-2RZTN9/HC5C3WTF1
6	19	6	2,34	0,95	0,04	110 000	70 000	0,0080	626-2RSLTN9/HC5C3WTF1
7	19	6	2,34	0,95	0,04	110 000	70 000	0,0070	607-2RSLTN9/HC5C3WTF1
	22	7	3,45	1,37	0,057	95 000	63 000	0,012	627-2RSLTN9/HC5C3WTF1
8	22	7	3,45	1,37	0,057	95 000	63 000	0,012	608-2RSLTN9/HC5C3WTF1
10	26	8	4,75	1,96	0,083	85 000	56 000	0,018	6000-2RSLTN9/HC5C3WT
	30	9	5,4	2,36	0,1	75 000	50 000	0,032	6200-2RSLTN9/HC5C3WT
12	28	8	5,4	2,36	0,1	75 000	50 000	0,022	6001-2RSLTN9/HC5C3WT
	32	10	7,28	3,1	0,132	67 000	45 000	0,037	6201-2RSLTN9/HC5C3WT
15	32	9	5,85	2,85	0,12	63 000	43 000	0,030	6002-2RSLTN9/HC5C3WT
	35	11	8,06	3,75	0,16	60 000	40 000	0,044	6202-2RSLTN9/HC5C3WT
17	35	10	6,37	3,25	0,137	56 000	38 000	0,038	6003-2RSLTN9/HC5C3WT
	40	12	9,95	4,75	0,2	53 000	34 000	0,059	6203-2RSLTN9/HC5C3WT
20	42	12	9,95	5	0,212	48 000	32 000	0,062	6004-2RSLTN9/HC5C3WT
	47	14	13,5	6,55	0,28	45 000	30 000	0,097	6204-2RSLTN9/HC5C3WT
25	47	12	11,9	6,55	0,275	40 000	28 000	0,073	6005-2RSLTN9/HC5C3WT
	52	15	14,8	7,8	0,335	38 000	26 000	0,12	6205-2RSLTN9/HC5C3WT
30	55	13	13,8	8,3	0,355	34 000	24 000	0,11	6006-2RZTN9/HC5C3WT
	62	16	20,3	11,2	0,475	32 000	22 000	0,18	6206-2RZTN9/HC5C3WT
35	62	14	16,8	10,2	0,44	30 000	20 000	0,15	6007-2RZTN9/HC5C3WT
	72	17	27	15,3	0,655	28 000	18 000	0,26	6207-2RZTN9/HC5C3WT
40	68	15	17,8	11,6	0,49	28 000	18 000	0,19	6008-2RZTN9/HC5C3WT
	80	18	32,5	19	0,8	24 000	16 000	0,34	6208-2RZTN9/HC5C3WT
45	85	19	35,1	21,6	0,915	22 000	14 000	0,42	6209-2RZTN9/HC5C3WT
	100	25	55,3	31,5	1,34	20 000	4 500	0,77	6309-2RS1TN9/HC5C3WT

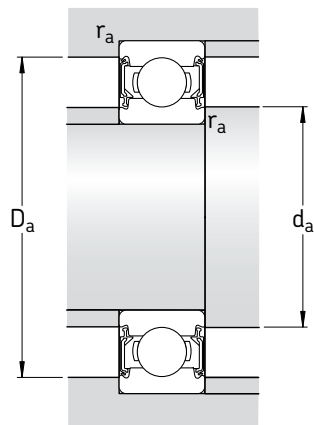

Dimensions					Abutment and fillet dimensions				Calculation factor
d	d_1	d_2	D_2	$r_{1,2}$ min	d_a min	d_a max	D_a max	r_a max	f_0
mm					mm				–
5	8,4	–	13,3	0,3	7,4	–	13,6	0,3	8,4
6	–	9,5	16,5	0,3	8,4	9,4	16,6	0,3	13
7	–	9,5	16,5	0,3	9	9,4	17	0,3	13
	–	10,6	19,2	0,3	9,4	10,5	19,6	0,3	12
8	–	10,6	19,2	0,3	10	10,5	20	0,3	12
10	–	13	22,6	0,3	12	12,5	24	0,3	12
	–	15,2	24,8	0,6	14,2	15	25,8	0,6	13
12	–	15,2	24,8	0,3	14	15	26	0,3	13
	–	16,6	27,4	0,6	16,2	16,5	27,8	0,6	12
15	–	18,7	28,2	0,3	17	18,5	30	0,3	14
	–	19,4	30,4	0,6	19,2	19,4	30,8	0,6	13
17	–	20,7	31,4	0,3	19	20,5	33	0,3	14
	–	22,2	35	0,6	21,2	22	35,8	0,6	13
20	–	24,9	37,2	0,6	23,2	24,5	38,8	0,6	14
	–	26,3	40,6	1	25,6	26	41,4	1	13
25	–	29,7	42,2	0,6	28,2	29,5	43,8	0,6	14
	–	31,8	46,3	1	30,6	31,5	46,4	1	14
30	38,2	–	49	1	34,6	–	50,4	1	15
	40,4	–	54,1	1	35,6	–	56,4	1	14
35	43,8	–	55,6	1	39,6	–	57,4	1	15
	46,9	–	62,7	1,1	42	–	65	1	14
40	49,3	–	61,1	1	44,6	–	63,4	1	15
	52,6	–	69,8	1,1	47	–	73	1	14
45	57,6	–	75,2	1,1	52	–	78	1	14
	62,2	–	86,7	1,5	54	–	91	1,5	13

**Sealed and greased-for-life
hybrid deep groove ball bearings**
d 50 – 75 mm

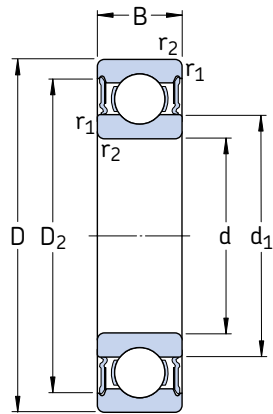

Principal dimensions			Basic load ratings		Fatigue load limit P_u	Speed ratings		Mass	Designation
d	D	B	dynamic C	static C_0		Reference speed	Limiting speed		
mm			kN		kN	r/min		kg	–
50	90	20	37,1	23,2	0,98	20 000	4 800	0,44	6210-2RS1/HC5C3WT
	110	27	65	38	1,6	18 000	4 300	0,92	6310-2RS1/HC5C3WT
55	100	21	46,2	29	1,25	19 000	4 300	0,59	6211-2RS1/HC5C3WT
	120	29	74,1	45	1,9	17 000	3 800	1,20	6311-2RS1/HC5C3WT
60	110	22	55,3	36	1,53	17 000	4 000	0,71	6212-2RS1/HC5C3WT
	130	31	85,2	52	2,2	15 000	3 400	1,50	6312-2RS1/HC5C3WT
65	120	23	58,5	40,5	1,73	16 000	3 600	0,92	6213-2RS1/HC5C3WT
	140	33	97,5	60	2,5	14 000	3 200	1,85	6313-2RS1/HC5C3WT
70	125	24	63,7	45	1,9	15 000	3 400	1,00	6214-2RS1/HC5C3WT
75	130	25	68,9	49	2,04	14 000	3 200	1,05	6215-2RS1/HC5C3WT

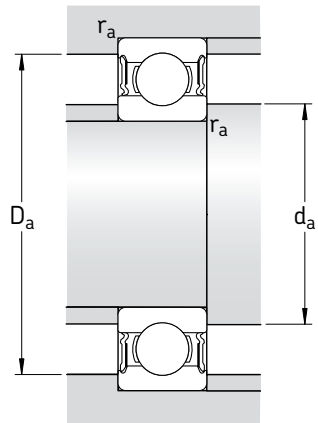

Dimensions			Abutment and fillet dimensions			Calculation factor	
d	d_1 ~	D_2 ~	$r_{1,2}$ min	d_a min	D_a max	r_a max	f_0
mm			mm			-	
50	62,5	81,6	1,1	57	83	1	14
	68,8	95,2	2	59	101	2	13
55	69,1	89,4	1,5	64	91	1,5	14
	75,3	104	2	66	109	2	13
60	75,5	98	1,5	69	101	1,5	14
	81,9	112	2,1	72	118	2	13
65	83,3	106	1,5	74	111	1,5	15
	88,4	121	2,1	77	128	2	13
70	87,1	111	1,5	79	116	1,5	15
75	92,1	117	1,5	84	121	1,5	15

Hybrid deep groove ball bearings
d 65 – 110 mm

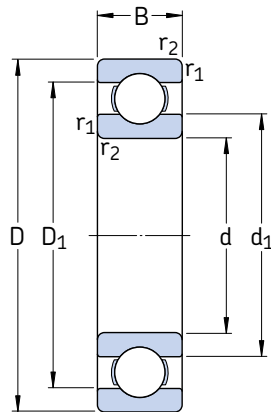

Principal dimensions			Basic load ratings		Fatigue load limit P_u	Speed ratings		Mass	Designation
d	D	B	dynamic C	static C_0		Reference speed	Limiting speed		
mm			kN		kN	r/min		kg	–
65	100	18	31,9	25	1,06	18 000	10 000	0,41	6013/HC5C3
	120	23	58,5	40,5	1,73	16 000	8 500	0,92	6213/HC5C3
70	110	20	39,7	31	1,32	16 000	9 000	0,57	6014/HC5C3
	125	24	63,7	45	1,9	15 000	8 500	0,99	6214/HC5C3
75	160	37	119	76,5	3	12 000	6 700	2,60	6315/HC5C3
80	170	39	130	86,5	3,25	12 000	6 300	2,80	6316/HC5C3
95	200	45	159	118	4,15	9 500	5 300	4,90	6319/HC5C3
110	240	50	203	180	5,7	8 000	4 500	8,15	6322/HC5C3T

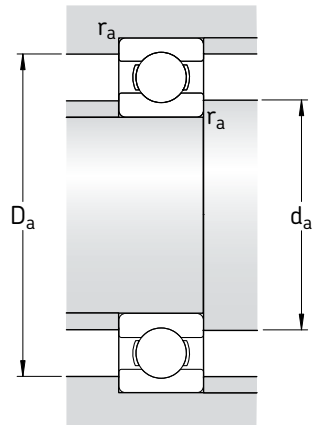

Dimensions				Abutment and fillet dimensions			Calculation factor
d	d_1 ~	D_1 ~	$r_{1,2}$ min	d_a min	D_a max	r_a max	f_0
mm				mm			-
65	76,3	91,5	1,1	71	94	1	16
	83,3	106	1,5	74	111	1,5	15
70	82,9	99,9	1,1	76	104	1	16
	87,1	111	1,5	79	116	1,5	15
75	101	138	2,1	87	148	2	13
80	108	147	2,1	92	158	2	13
95	121	172	3	109	186	2,5	13
110	149	205	3	124	226	2,5	13



INSOCOAT[®] bearings

INSOCOAT bearing designs	913
INSOCOAT bearings with coated outer ring	913
INSOCOAT bearings with coated inner ring.....	913
Other INSOCOAT bearings	913
Bearing data – general	914
Dimensions.....	914
Tolerances.....	914
Internal clearance.....	914
Cages.....	914
Minimum load.....	914
Axial load carrying capacity.....	914
Equivalent bearing loads.....	914
Electrical properties	914
Design of associated components	915
Mounting and maintenance	915
Additional information	915
Product tables	916
INSOCOAT deep groove ball bearings.....	916
INSOCOAT cylindrical roller bearings	918

INSOCOAT bearings

Rolling bearings in electric motors, generators or associated equipment are at risk from the passage of electric current, which can damage the surfaces of rolling elements and raceways in the bearing and degrade the grease rapidly. The risk of damage, so called electric erosion, increases greatly if a frequency converter controls the electrical machinery, which is becoming increasingly common. An additional risk for high frequency bearing currents occurs in the application due to the inherent stray capacitances within the electrical machinery.

To protect the bearings against electric current passage, SKF has developed INSOCOAT® bearings – electrically insulated rolling bearings (→ **fig. 1**). An INSOCOAT bearing is a very economical solution compared with other insulation methods to protect the bearing. By integrating the electrical insulation function into the bearing, SKF has been able to increase reliability and machine uptime by virtually eliminating electric erosion problems.

INSOCOAT bearings have a nominal 100 µm thick layer of aluminium oxide on the exterior surfaces of the outer or inner ring, that can withstand voltages up to 1 000 V DC. The SKF plasma spray coating technique provides an extremely coherent coating of uniform thickness, which is further treated to make it insensitive to moisture and humidity.

SKF INSOCOAT bearings are robust and should be handled in the same way as normal non-insulated bearings.



Fig. 1

INSOCOAT bearing designs

SKF INSOCOAT bearings are available from stock as

- single row deep groove ball bearings
- single row cylindrical roller bearings

in the most frequently used sizes and variants. The performance data as well as the dimensional and running accuracy of the INSOCOAT bearings are identical to those of standard non-insulated bearings.

The SKF standard range includes bearings either with coated outer ring or coated inner ring of open design. Deep groove ball bearings with Z shields or with RS1 contact seals can also be supplied by SKF. Before deciding upon design and ordering, please consult the SKF application engineering service.

INSOCOAT bearings with coated outer ring

Bearings with electrically insulating coating on the external surfaces of the outer ring are the most common INSOCOAT bearings. They are identified by the suffix VL0241.

For applications where smaller bearings are needed than listed in the product table on **page 916**, SKF recommends the use of hybrid deep groove ball bearings (→ **page 897**).

INSOCOAT bearings with coated inner ring

Bearings with electrically insulating coating on the external surfaces of the inner ring (→ **fig. 2**) provide enhanced protection against electric erosion due to the increased impedance because of the smaller coated surface area. They are identified by the suffix VL2071.

Other INSOCOAT bearings

If the standard range of INSOCOAT deep groove ball bearings and cylindrical roller bearings is inadequate please contact the SKF application engineering service for information about the complete manufacturing programme of INSOCOAT bearings. Other types and sizes of INSOCOAT bearings that are not listed in the standard range and INSOCOAT bearings with an aluminium-oxide layer up to 300 µm thickness on the bearing outer ring are available on request.



Bearing data – general

Dimensions

The boundary dimensions of INSOCOAT deep groove ball bearings as well as cylindrical roller bearings are in accordance with ISO 15:1998.

Tolerances

The INSOCOAT bearings are produced to Normal tolerances. Some deep groove ball bearings are also available with higher accuracy to tolerance class P5. The values of the tolerances conform to ISO 492:2002 and are shown in **tables 3 and 5** on **pages 125 and 127**.

The aluminium-oxide layer applied either to the external surfaces of the outer ring or the inner ring does not influence the accuracy.

Internal clearance

INSOCOAT deep groove ball bearings and cylindrical roller bearings are manufactured as standard with radial internal clearance shown within the bearing designation. The availability of bearings with clearance other than standard should be checked before ordering.

The clearance limits can be found for

- the deep groove ball bearings in **table 4** on **page 297**
- the cylindrical roller bearings in **table 1** on **page 513**.

The values are valid before mounting under zero measuring load.

Cages

Depending on the bearing type and size, INSOCOAT bearings are fitted as standard with one of the following cages

- an injection moulded window-type cage of glass fibre reinforced polyamide 6,6, ball centred, designation suffix P
- a riveted cage of pressed steel, ball centred, no designation suffix
- a two-piece machined brass cage, rolling element centred, designation suffix M.

For more detailed information on these cages please refer to the sections “Deep groove ball

bearings”, starting on **page 287**, and “Cylindrical roller bearings”, starting on **page 503**.

Minimum load

In order to provide satisfactory operation, INSOCOAT rolling bearings, like the non-insulated standard bearings, must always be subjected to a given minimum load. The recommendations for calculating the requisite minimum loads are identical to those of the standard non-insulated bearings and can be found for

- deep groove ball bearings on **page 298**
- cylindrical roller bearings on **page 517**.

Axial load carrying capacity

The axial load carrying capacity of INSOCOAT bearings is identical to that of the standard non-insulated bearings. Recommendations can be found for

- deep groove ball bearings on **page 299**
- cylindrical roller bearings on **page 518**.

Equivalent bearing loads

Recommendations for calculating the equivalent dynamic and static bearing loads of INSOCOAT bearings are identical to those of the corresponding standard bearings. They can be found for

- deep groove ball bearings on **page 299**
- cylindrical roller bearings on **page 519**.

Electrical properties

The INSOCOAT layer provides effective protection against AC and DC currents. The minimum ohmic resistance is 50 MΩ at 1 000 V DC. Tests at SKF have shown that electrical breakdown of the insulating layer occurs above 3 000 V DC.

Design of associated components

For insulation reasons it is recommended that for

- bearings with coated outer ring, type VL0241, the housing shoulder or spacer sleeve should not have a smaller diameter than the abutment dimension $D_{a\ min}$ (→ **fig. 3a**) listed in the product tables
- bearings with coated inner ring, type VL2071, the shaft shoulder or spacer sleeve should not have a larger diameter than the abutment dimension $d_{a\ max}$ (→ **fig. 3b**) listed in the product tables.

Mounting and maintenance

During mounting INSOCOAT bearings should be handled in the same way as standard bearings. Proper lubrication is important to utilize fully the service life of INSOCOAT bearings. The best method is frequent regreasing.

Additional information

For additional information concerning INSOCOAT bearings, please contact the SKF application engineering service.

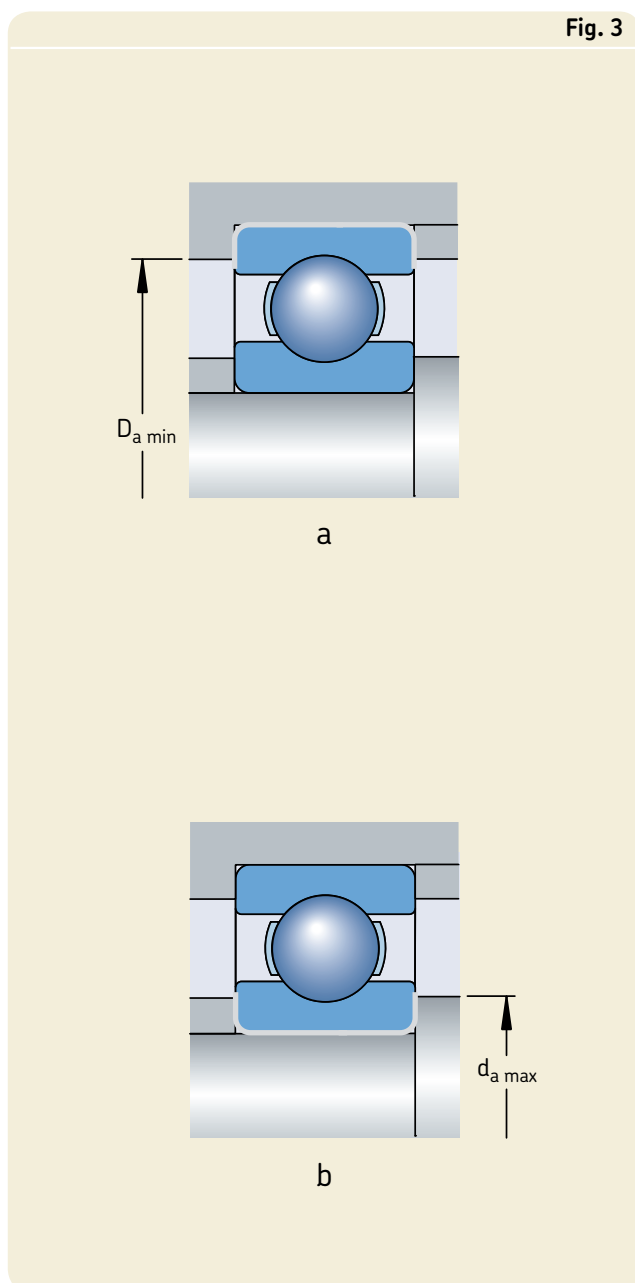

INSOCOAT deep groove ball bearings
d 70 – 150 mm

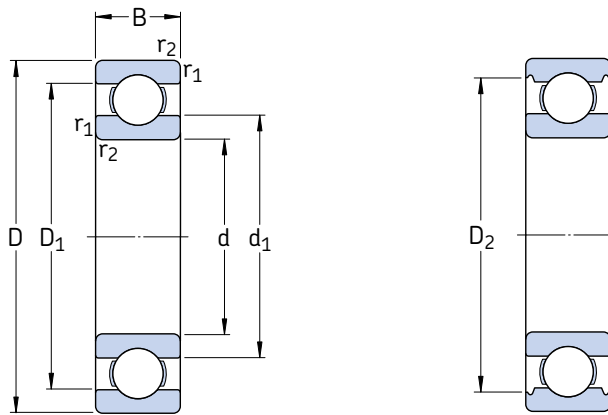

Principal dimensions			Basic load ratings		Fatigue load limit P_u	Speed ratings		Mass	Designation
d	D	B	dynamic C	static C_0		Reference speed	Limiting speed		
mm			kN		kN	r/min		kg	–
70	150	35	104	68	2,75	9 500	6 300	2,50	6314/C3VL0241
75	130 160	25 37	66,3 114	49 76,5	2,04 3	10 000 9 000	6 700 5 600	1,40 3,05	6215/C3VL0241 6315/C3VL0241
80	140 170	26 39	70,2 124	55 86,5	2,2 3,25	9 500 8 500	6 000 5 300	1,40 3,55	6216/C3VL0241 6316/C3VL0241
85	150 180	28 41	83,2 133	64 96,5	2,5 3,55	9 000 8 000	5 600 5 000	1,75 4,10	6217/C3VL0241 6317/C3VL0241
90	160 190	30 43	95,8 143	73,5 108	2,8 3,8	8 500 7 500	5 300 4 800	2,40 4,90	6218/C3VL0241 6318/C3VL0241
95	170 200	32 45	114 153	81,5 118	3 4,15	8 000 7 000	5 000 4 500	2,50 5,65	6219/C3VL0241 6319/C3VL0241
100	180 215	34 47	124 174	93 140	3,35 4,75	7 500 6 700	4 800 4 300	3,15 7,00	6220/C3VL0241 6320/C3VL0241
110	200 240	38 50	143 203	118 180	4 5,7	6 700 6 000	4 300 3 800	4,25 9,65	6222/C3VL0241 6322/C3VL0241
120	215 260	40 55	146 208	118 186	3,9 5,7	6 300 5 600	4 000 3 400	5,20 12,2	6224/C3VL0241 6324/C3VL2071
130	230 280	40 58	156 229	132 216	4,15 6,3	5 600 5 000	3 600 3 200	5,75 14,7	6226/C3VL2071 6326/C3VL2071
140	300	62	251	245	7,1	4 800	4 300	21,3	6328 M/C3VL2071
150	270 320	45 65	174 276	166 285	4,9 7,8	5 000 4 300	3 200 4 000	9,80 22,8	6230/C3VL2071 6330/C3VL2071

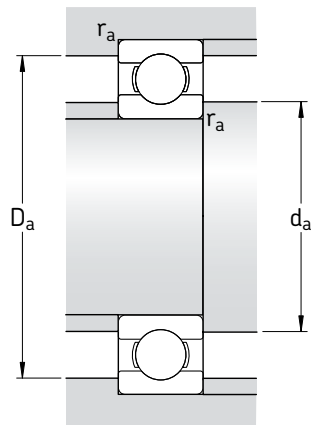

Dimensions					Abutment and fillet dimensions					Calculation factors	
d	d ₁ ~	D ₁ ~	D ₂ ~	r _{1,2} min	d _a min	d _a max	D _a min	D _a max	r _a max	k _r	f ₀
mm					mm					-	
70	95	126	132	2,1	82	-	136	138	2	0,03	13
75	92 101	114 134	118 141	1,5 2,1	84 87	- -	121 146	121 148	1,5 2	0,025 0,03	15 13
80	101 108	127 143	122 149	2 2,1	91 92	- -	128 154	129 158	2 2	0,025 0,03	15 13
85	106 115	130 152	134 158	2 3	96 99	- -	139 163	139 166	2 2,5	0,025 0,03	15 13
90	112 121	139 160	145 166	2 3	101 104	- -	149 171	149 176	2 2,5	0,025 0,03	15 13
95	118 127	146 169	151 174	2,1 3	107 109	- -	156 179	158 186	2 2,5	0,025 0,03	14 13
100	125 135	155 181	160 186	2,1 3	112 114	- -	165 191	168 201	2 2,5	0,025 0,03	14 13
110	138 149	173 201	179 207	2,1 3	122 124	- -	184 213	188 226	2 2,5	0,025 0,03	14 13
120	151 164	184 216	189 -	2,1 3	132 134	- 158	194 -	203 246	2 2,5	0,025 0,03	14 14
130	160 177	199 233	205 -	3 4	144 147	154 171	- -	216 263	2,5 3	0,025 0,03	15 14
140	190	250	-	4	157	185	-	283	3	0,03	14
150	190 206	229 265	- -	3 4	164 167	185 200	- -	256 303	2,5 3	0,025 0,03	15 14

INSOCOAT cylindrical roller bearings
d 75 – 120 mm

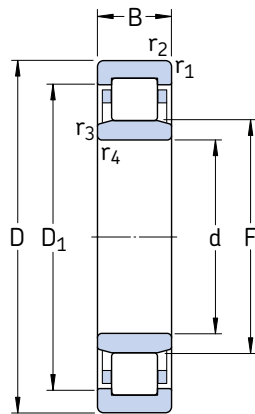

Principal dimensions			Basic load ratings		Fatigue load limit P_u	Speed ratings		Mass	Designation
d	D	B	dynamic C	static C_0		Reference speed	Limiting speed		
mm			kN		kN	r/min	kg	–	
75	160	37	280	265	33,5	4 500	5 300	3,30	* NU 315 ECP/VL0241
85	180	41	340	335	41,5	4 000	4 800	5,25	* NU 317 ECM/C3VL0241
90	160	30	208	220	27	4 500	5 000	2,75	* NU 218 ECM/C3VL0241
95	200	45	390	390	46,5	3 600	4 300	7,25	* NU 319 ECM/C3VL0241
110	240	50	530	540	61	3 000	3 400	12,0	* NU 322 ECM/C3VL0241
120	260	55	610	620	69,5	2 800	3 200	15,2	* NU 324 ECM/C3VL0241

* SKF Explorer bearing

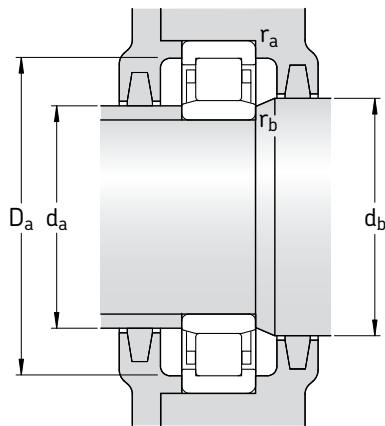

Dimensions						Abutment and fillet dimensions							Calculation factor
d	D_1 ~	F	$r_{1,2}$ min	$r_{3,4}$ min	$s^1)$	d_a min	d_a max	d_b min	D_a min	D_a max	r_a max	r_b max	k_r
mm						mm							–
75	136	95	2,1	2,1	1,8	87	92	97	141	148	2	2	0,15
85	153	108	3	3	2,3	99	105	111	158	166	2,5	2,5	0,15
90	139	107	2	2	1,8	101	104	110	144	149	2	2	0,15
95	170	121,5	3	3	2,9	109	118	124	175	186	2,5	2,5	0,15
110	201	143	3	3	3	124	139	146	207	226	2,5	2,5	0,15
120	219	154	3	3	3,7	134	150	157	225	246	2,5	2,5	0,15

¹⁾ Permissible axial displacement from the normal position of one bearing ring in relation to the other

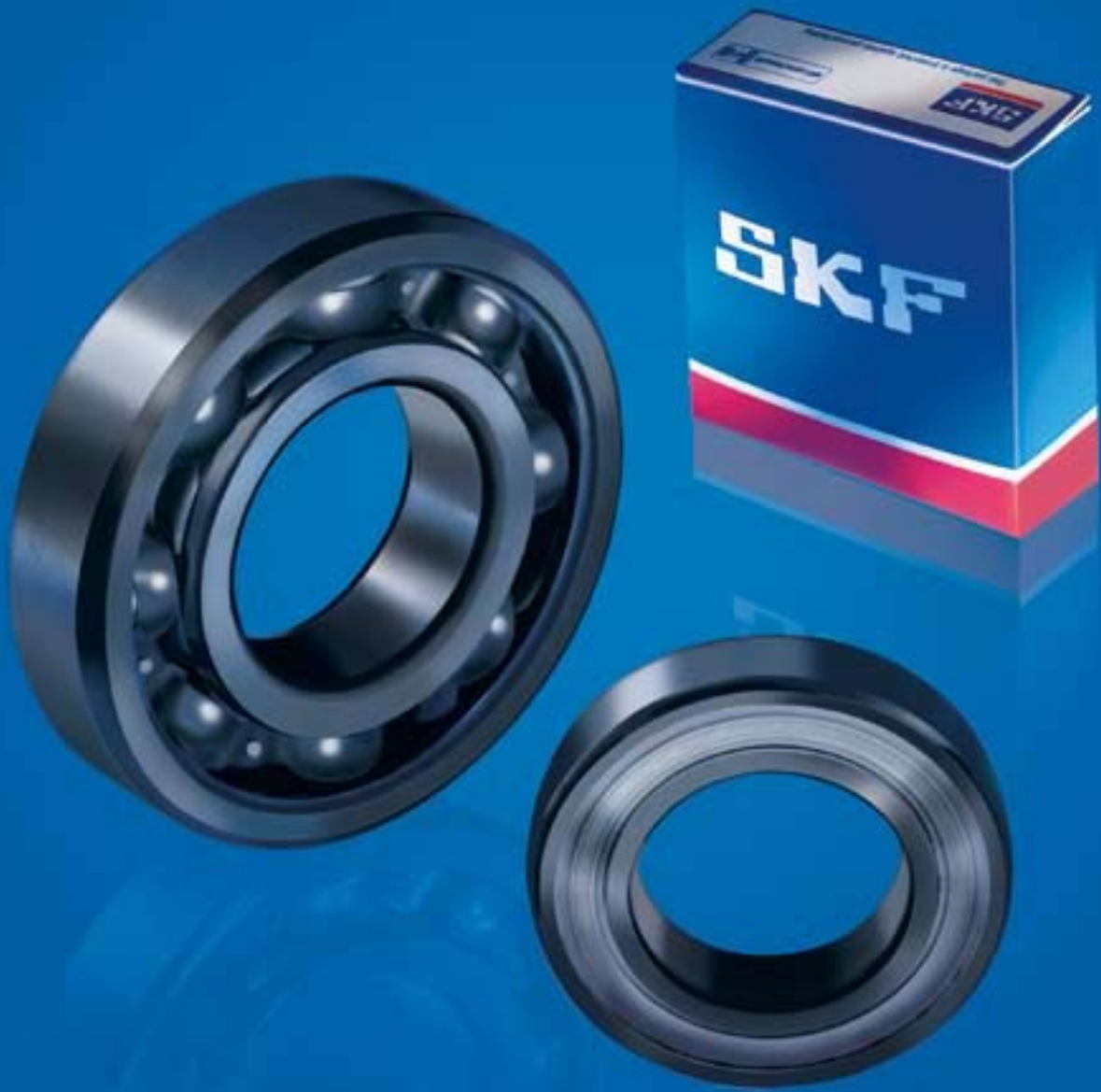

Bearings and bearing units for high temperatures

Deep groove ball bearing for high temperatures	923
VA201 design for the most common applications	923
2Z/VA201 design with protective shields.....	923
2Z/VA208 design for high demands.....	923
2Z/VA228 design for top requirements	923
2Z/VA216 design for aggressive environments	924
Y-bearings for high temperatures	924
Y-bearings of the VA201 and VA228 designs	924
Y-bearing units for high temperatures	925
Bearing data – general	926
Dimensions.....	926
Tolerances.....	926
Internal clearance.....	926
Misalignment.....	926
Speeds	927
Design of associated components	927
Selection of bearing size	928
Maintenance	929
Additional information	929
Product tables	930
Single row deep groove ball bearings for high temperatures	930
Y-bearings for high temperatures with grub screw locking for metric shafts.....	934
Y-bearings for high temperatures with grub screw locking for inch shafts.....	935
Y-bearing plummer (pillow) block units for high temperatures and metric shafts.....	936
Y-bearing plummer (pillow) block units for high temperatures and inch shafts.....	937
Y-bearing flanged units with square housing for high temperatures and metric shafts.....	938
Y-bearing flanged units with square housing for high temperatures and inch shafts.....	939
Y-bearing flanged units with oval housing for high temperatures and metric shafts	940
Y-bearing flanged units with oval housing for high temperatures and inch shafts	941

Bearings and bearing units for high temperatures

Fig. 1



For bearing arrangements, which have to operate at extreme temperatures in the range -150 to $+350$ °C, or which have to withstand very large temperature differences, e.g. in kiln trucks, furnaces or the conveyor systems of lacquering equipment, normal rolling bearings are unsuitable. SKF has therefore developed high-temperature

- deep groove ball bearings (→ **fig. 1**)
- Y-bearings (→ **fig. 2**)
- Y-bearing plummer block units (→ **fig. 3**)
- Y-bearing flanged units

to meet the widely differing engineering demands for

- reduced machine operating costs
- extended maintenance-free service life
- and high operational reliability

Fig. 2



in this wide temperature range, even in a severe environment. The bearings and units for high temperature belonging to the SKF standard assortment are described in the following and listed in the relevant product tables. To special order SKF can produce bearings for extreme low or high temperatures, which are engineered to meet specific needs. If such engineering products are required, the SKF application engineering service should be contacted.

Fig. 3



Deep groove ball bearings for high temperatures

SKF deep groove ball bearings for high as well as low temperatures correspond in design to the appropriate standard single row deep groove ball bearings. They have no filling slots and are able to accommodate moderate axial loads in addition to radial loads. The characteristic features of these bearings include large radial internal clearance and special cages. The large clearance is four times the C5 clearance and prevents the bearings from seizing even when they are rapidly cooled. All surfaces of the bearings and the shields are manganese phosphated. This provides protection against corrosion and improves running properties.

SKF deep groove ball bearings for high temperatures have a cylindrical bore and are available in five different designs as described in the following.

VA201 design for the most common applications

Bearings of the VA201 design (→ fig. 4a) are not sealed and have a pressed steel cage. They are lubricated with a polyalkylene glycol/graphite mixture which can be used at temperatures between -40 and $+250$ °C. At temperatures above $+200$ °C, dry lubrication pertains.

2Z/VA201 design with protective shields

The bearings of the 2Z/VA201 design (→ fig. 4b) are of the same design as the VA201 bearings but have protective shields on both sides to prevent the ingress of solid contaminants. Additionally, these bearings have twice the amount of the polyalkylene glycol/graphite mixture as the open VA201 design bearings.

Note

Bearings of the 2Z/VA201 design are not recommended for mainly non-rotating applications.

2Z/VA208 design for high demands

These bearings (→ fig. 4c) have a segmented cage of graphite and can be used at temperatures between -150 and $+350$ °C. The segments separate the balls and also provide the necessary lubrication. The bearings are fitted with two shields, which axially guide the cage segments and prevent the entry of solid contaminants. The minute quantities of graphite powder released by the cage during rotation provide adequate lubrication for the bearing.

An additional advantage of these bearings is that they are environmentally friendly. Even at maximum temperatures, no dangerous gases or vapours are emitted.

2Z/VA228 design for top requirements

The 2Z/VA228 design bearings (→ fig. 4d) are the “top-of-the-range” among SKF products

Fig. 4

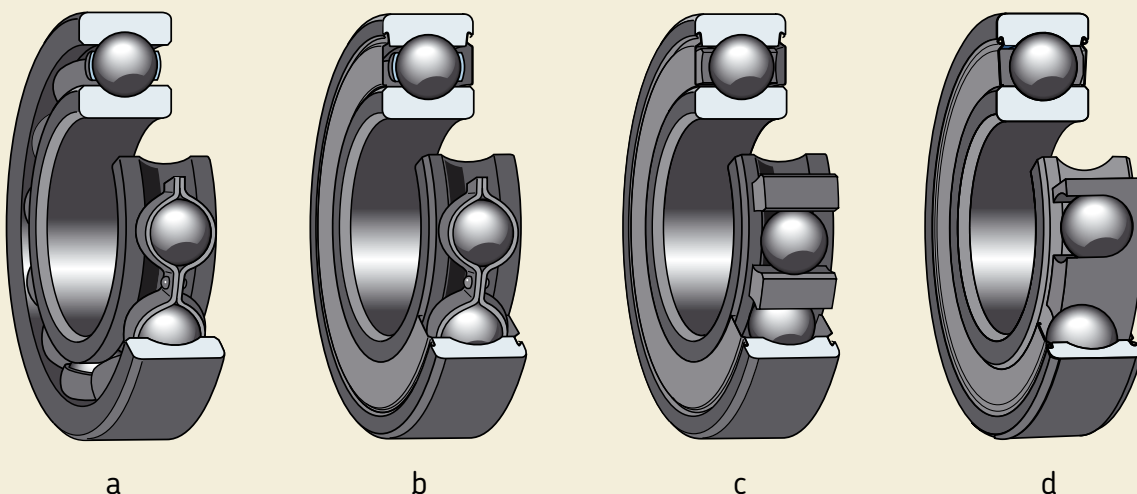

Bearings and bearing units for high temperatures

for high temperatures. They are fitted with a “coronet” cage of pure graphite, which opens up additional application areas for these high-temperature bearings. The coronet cage is a unique SKF development and permits operating speeds of up to 100 r/min.

In all other respects the bearings are the same as the VA208 bearings.

2Z/VA216 design for aggressive environments

For bearing arrangements where the environment is particularly aggressive, bearings of the 2Z/VA216 design are recommended. These bearings are charged with a creamy-white multi-purpose grease based on a fluorized polyether oil mixed with PTFE, for operating temperatures from -40 to $+230$ °C. Otherwise the bearings have the same design as 2Z/VA201.

For normal cases, the lubricant fill is between 25 and 35 % of the free space in the bearing. On request other filling grades can be supplied.

Y-bearings for high temperatures

SKFY-bearings for high temperatures correspond in design to the appropriate Y-bearings in the YAR 2-2FW series with grub screws. The characteristic features of these bearings for extreme temperatures include large radial internal clearance and special cages and shields. As for the high-temperature deep groove ball bearings all surfaces of the Y-bearings are manganese phosphated. This provides protection against corrosion and improves running properties.

SKFY-bearings for high as well as low temperatures are available in two different designs.

Y-bearings of the VA201 and VA228 designs

Y-bearings of the VA201 (→ fig. 5a) and the VA228 (→ fig. 5b) designs have the same features as the deep groove ball bearing designs having the same V-number identification, with the exception of the bearing clearance, which is only twice the C5 clearance. The Y-bearings are fitted with pressed steel shields and flingers on both sides, which protect the bearings from solid contaminants.

Fig. 5

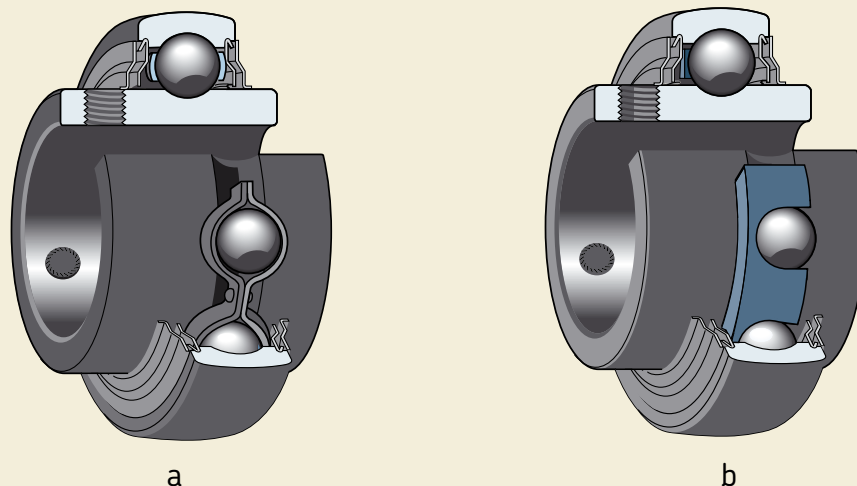

Fig. 6



Y-bearing units for high temperatures

Y-bearing units for high temperatures have a grey cast iron housing and are available in three different designs as

- plummer (pillow) block units (→ **fig. 6**)
- flanged units with square housing and four bolt holes (→ **fig. 7**)
- flanged units with oval housing and two bolt holes (→ **fig. 8**).

The Y-bearings incorporated are described above.

The cast housings of the units are interchangeable with those of the standard Y-bearing units except for a few sizes where some dimensions differ slightly. The housings are zinc coated and yellow chromated to provide better protection against corrosion.

The housings do not have a grease nipple as the incorporated bearings are lubricated for life. The housing bore is coated with a lubricating paste and the tolerances are such that alignment is maintained at all times and at all temperatures.

Fig. 7



Fig. 8



Bearing data – general

Dimensions

The boundary dimensions of

- the deep groove ball bearings are in accordance with ISO 15:1998
- the Y- bearings are in accordance with ISO 9628:1992
- the Y- bearing units are in accordance with ISO 3228:1993.

Tolerances

The deep groove ball bearings and the Y-bearings are produced to Normal tolerances in accordance with

- ISO 492:2002 (→ **table 5, page 125**) and
- ISO 9628:1992 (→ **table 1**), respectively.

However, because the bearings have been especially surface treated to protect against corrosion and improve running properties, there may be slight deviations from the standard tolerances. Any such deviations will have no influence on mounting or bearing operation.

The Y-bearings for inch shafts are made to the same tolerances as the corresponding basic bearing for metric shafts.

The tolerances for the height of the shaft axis above the support surface, dimension H_1 of the plummer block units are 0/–0,25 mm.

Internal clearance

SKF deep groove ball bearings for high temperatures are manufactured with four times the standard C5 clearance. The Y-bearings and the corresponding Y-bearing units have twice the standard C5 clearance according to ISO 5753:1991.

The clearance limits for the various bearings can be found in **table 2** and are valid before mounting under zero measuring load.

Misalignment

Because of their large internal clearance, the deep groove ball bearings for high temperatures can tolerate angular misalignments of the outer ring in relation to the inner ring of 20 to 30 minutes of arc. This applies only when the bearings rotate slowly as the rolling conditions in the bearing under such misalignments are unfavourable.

During mounting Y-bearing units are able to compensate for errors of alignment up to 5°.

Table 1

Tolerances of Y-bearings					
Nominal diameter d, D		Bore diameter Deviation high low		Outside diameter Deviation high low	
over	incl.				
mm		µm		µm	
18	30	+18	0	–	–
30	50	+21	0	0	-10
50	80	+24	0	0	-10
80	120	+28	0	0	-15

Table 2

Radial internal clearance					
Bore diameter d		Radial internal clearance			
over	incl.	Deep groove ball bearings		Y-bearings units	
		min	max	min	max
mm		µm		µm	
10	10	80	148	–	–
18	18	100	180	–	–
18	24	112	192	56	96
24	30	120	212	60	106
30	40	160	256	80	128
40	50	180	292	90	146
50	65	220	360	110	180
65	80	260	420	–	–
80	100	300	480	–	–
100	120	360	560	–	–

Speeds

SKF deep groove ball bearings as well as Y-bearings for high temperatures in the VA201, VA208 and VA228 design are developed for bearing arrangements where they rotate slowly, i.e. a few revolutions per minute. Experience has shown, however, that it is possible to run bearings for long periods at speeds up to 100 r/min without maintenance. It is recommended to contact the SKF application engineering service if the bearings are to be used at higher speeds.

Design of associated components

It is advisable to provide support to the shields of deep groove ball bearings of the 2Z/VA228 and 2Z/VA208 design because of the axial guidance they have to provide for the graphite cage (→ **fig. 9**). Therefore, it is recommended that the housing shoulder or the bore diameter of the spacer sleeve should have a smaller diameter than the outer ring shoulder diameter D_2 provided in the product table. If this is not possible a support washer with the appropriate housing bore diameter should be inserted between the bearing and housing shoulder or spacer sleeve.

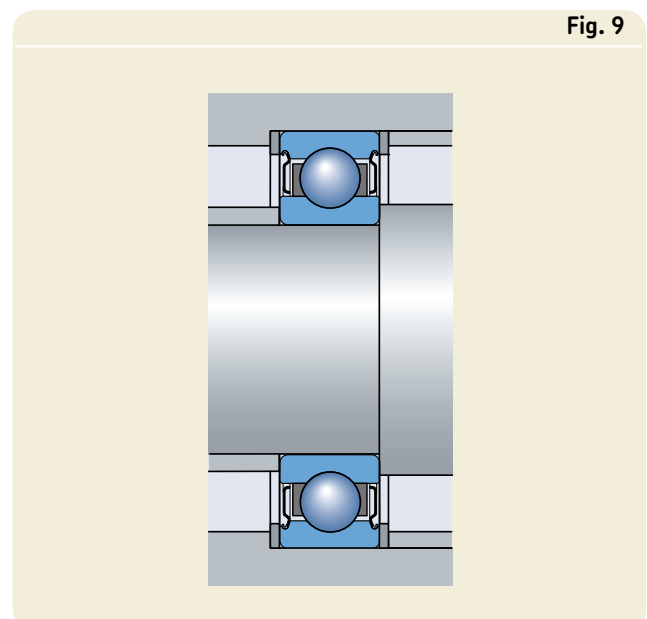

Selection of bearing size

The requisite size is determined based on the basic static load rating C_0 , as bearings and bearing units for high temperatures rotate at very slow speeds.

At high temperatures, the load carrying capacity of a bearing is reduced. This is taken into account by multiplying the basic static load rating C_0 by a temperature factor f_T .

The requisite basic static load rating can be determined using

$$C_{0 \text{ req}} = 2 P_0 / f_T$$

where

$C_{0 \text{ req}}$ = requisite basic static load rating, kN

P_0 = equivalent static bearing load, kN

f_T = temperature factor (→ **table 3**)

The equivalent static bearing load P_0 is obtained from

$$P_0 = 0,6 F_r + 0,5 F_a$$

where

F_r = actual radial bearing load, kN

F_a = actual axial bearing load, kN

When calculating P_0 the maximum load that can occur should be used and its radial and axial components inserted in the equation above. If $P_0 < F_r$, then $P_0 = F_r$ should be used.

Temperature factor f_T	
Operating temperature	Factor f_T
°C	–
150	1
200	0,95
250	0,9
300	0,8
350	0,64

For different loads and temperatures the requisite basic static load rating $C_{0 \text{ req}}$ is shown in **table 4**. Using the requisite basic static load rating calculated from the above, or taken from **table 4**, a suitable bearing or Y-bearing unit can be selected from the product tables.

The bearing or Y-bearing unit selected should have a C_0 value that is equal to or greater than the requisite value.

Bearing load P_0	Requisite basic static load rating $C_{0 \text{ req}}$ for operating temperatures up to				
	150 °C	200 °C	250 °C	300 °C	350 °C
kN	kN				
0,5	1	1,05	1,11	1,2	1,56
1	2	2,1	2,22	2,5	3,12
2	4	4,2	4,44	5	6,25
3	6	6,3	6,67	7,5	9,4
4	8	8,4	8,9	10	12,5
5	10	10,5	11,1	12,5	15,6
6	12	12,6	13,3	15	18,8
7	14	14,7	15,5	17,5	21,9
8	16	16,8	17,8	20	25
9	18	18,9	19,9	22,5	28,1
10	20	21	22,2	25	31,3
11	22	23,1	24,5	27,5	34,4
12	24	25,2	26,7	30	37,5
13	26	27,3	29	32,5	40,5
14	28	29,4	31,1	35	44
15	30	31,5	33,3	37,5	47
16	32	33,6	35	40	50
17	34	35,7	37,8	42,5	53
18	36	37,8	40	45	56
19	38	40	42	47,5	60
20	40	42	44,5	50	62,5
22	44	46	49	55	69
24	48	50,5	53	60	75
26	52	54,5	58	65	81
28	56	59	62	70	87,5
30	60	63	66,5	75	94
32	64	67	71	80	–
34	68	71,5	75,5	85	–
36	72	75,5	80	90	–
38	76	80	84,5	85	–
40	80	84	89	–	–
42	84	88,5	9,5	–	–
44	88	92,5	–	–	–

Maintenance

SKF bearings and Y-bearing units for high temperatures are lubricated for life and are therefore without any relubrication facility. The open deep groove ball bearings of the VA201 design however should be inspected after some six months of operation. It is sufficient to open the housing or in case of kiln trucks to withdraw the wheel with the bearing from the journal and to remove contaminants using bellows.

If there is no longer a film of dry lubricant on the raceways, indicated by a bright metallic shiny track, the bearing should be re-lubricated using the original black, high-temperature paste, which is a mixture of polyalkylene glycol and graphite.

Additional information

For additional information about

- selection of bearing type
- selection of bearing size
- arrangement design
- mounting and dismounting
- maintenance,

please ask for appropriate information material or contact the SKF application engineering service.

Single row deep groove ball bearings
for high temperatures
d 10 – 45 mm

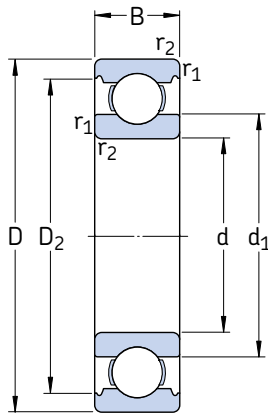

VA201

2Z/VA201

2Z/VA208

2Z/VA228

Dimensions						Basic static load rating C_0	Mass	Designation
d	D	B	d_1	D_2	$r_{1,2}$ min			
mm						kN	kg	–
10	35	11	17,5	28,7	0,6	3,4	0,053	6300-2Z/VA201
12	32	10	18,2	27,4	0,6	3,1	0,037	6201/VA201
	32	10	18,2	27,4	0,6	3,1	0,037	6201-2Z/VA201
	32	10	18,2	27,4	0,6	3,1	0,037	6201-2Z/VA228
15	35	11	21,5	30,4	0,6	3,75	0,045	6202/VA201
	35	11	21,5	30,4	0,6	3,75	0,045	6202-2Z/VA201
	35	11	21,5	30,4	0,6	3,75	0,043	6202-2Z/VA228
17	35	10	22,7	31,2	0,3	3,25	0,039	6003/VA201
	40	12	24,2	35	0,6	4,75	0,065	6203/VA201
	40	12	24,2	35	0,6	4,75	0,065	6203-2Z/VA201
	40	12	24,2	35	0,6	4,75	0,060	6203-2Z/VA228
20	42	12	27,2	37,2	0,6	5	0,068	6004-2Z/VA208
	47	14	28,5	40,6	1	6,55	0,11	6204/VA201
	47	14	28,5	40,6	1	6,55	0,11	6204-2Z/VA201
	47	14	28,5	40,6	1	6,55	0,10	6204-2Z/VA228
	52	15	30,3	44,8	1,1	7,8	0,13	6304/VA201
	52	15	30,3	44,8	1,1	7,8	0,13	6304-2Z/VA201
25	47	12	32	42,2	0,6	6,55	0,08	6005/VA201
	47	12	32	42,2	0,6	6,55	0,08	6005-2Z/VA201
	47	12	32	42,2	0,6	6,55	0,08	6005-2Z/VA208
	52	15	34	46,3	1	7,8	0,13	6205/VA201
	52	15	34	46,3	1	7,8	0,13	6205-2Z/VA201
	52	15	34	46,3	1	7,8	0,12	6205-2Z/VA228
	62	17	36,6	52,7	1,1	11,6	0,23	6305/VA201
	62	17	36,6	52,7	1,1	11,6	0,22	6305-2Z/VA228

Dimensions						Basic static load rating C_0	Mass	Designation	
d	D	B	d_1 ~	D_2 ~	$r_{1,2}$ min				
mm						kN	kg	–	
30	55	13	38,2	49	1	8,3	0,11	6006-2Z/VA208	
	62	16	40,3	54,1	1	11,2	0,20	6206/VA201	
	62	16	40,3	54,1	1	11,2	0,20	6206-2Z/VA201	
	62	16	40,3	54,1	1	11,2	0,19	6206-2Z/VA208	
	62	16	40,3	54,1	1	11,2	0,19	6206-2Z/VA228	
	72	19	44,6	61,9	1,1	16	0,35	6306/VA201	
	72	19	44,6	61,9	1,1	16	0,34	6306-2Z/VA208	
	72	19	44,6	61,9	1,1	16	0,34	6306-2Z/VA228	
	35	72	17	46,9	62,7	1,1	15,3	0,29	6207/VA201
		72	17	46,9	62,7	1,1	15,3	0,29	6207-2Z/VA201
72		17	46,9	62,7	1,1	15,3	0,28	6207-2Z/VA208	
72		17	46,9	62,7	1,1	15,3	0,28	6207-2Z/VA228	
80		21	49,5	69,2	1,5	19	0,46	6307/VA201	
80		21	49,5	69,2	1,5	19	0,44	6307-2Z/VA208	
40	68	15	49,2	61,1	1	11,6	0,17	6008-2Z/VA208	
	80	18	52,6	69,8	1,1	19	0,37	6208/VA201	
	80	18	52,6	69,8	1,1	19	0,37	6208-2Z/VA201	
	80	18	52,6	69,8	1,1	19	0,35	6208-2Z/VA208	
	80	18	52,6	69,8	1,1	19	0,35	6208-2Z/VA228	
	90	23	56,1	77,7	1,5	24	0,63	6308/VA201	
	90	23	56,1	77,7	1,5	24	0,63	6308-2Z/V201	
	90	23	56,1	77,7	1,5	24	0,61	6308-2Z/VA208	
	90	23	56,1	77,7	1,5	24	0,61	6308-2Z/VA228	
	45	85	19	57,6	75,2	1,1	21,6	0,41	6209/VA201
85		19	57,6	75,2	1,1	21,6	0,41	6209-2Z/VA201	
85		19	57,6	75,2	1,1	21,6	0,39	6209-2Z/VA208	
85		19	57,6	75,2	1,1	21,6	0,39	6209-2Z/VA228	
100		25	62,1	86,7	1,5	31,5	0,83	6309/VA201	
100		25	62,1	86,7	1,5	31,5	0,79	6309-2Z/VA208	

**Single row deep groove ball bearings
for high temperatures
d 50 – 120 mm**

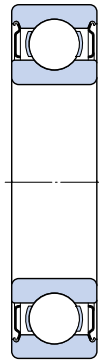
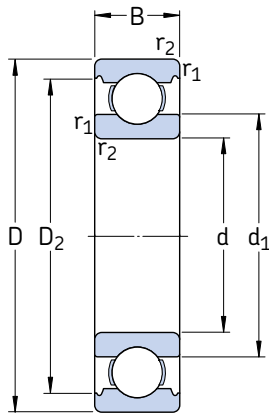

VA201

2Z/VA201

2Z/VA208

2Z/VA228

Dimensions						Basic static load rating C_0	Mass	Designation
d	D	B	d_1	D_2	$r_{1,2}$ min			
mm						kN	kg	–
50	90	20	62,5	81,7	1,1	23,2	0,46	6210/VA201
	90	20	62,5	81,7	1,1	23,2	0,46	6210-2Z/VA201
	90	20	62,5	81,7	1,1	23,2	0,45	6210-2Z/VA208
	90	20	62,5	81,7	1,1	23,2	0,45	6210-2Z/VA228
	110	27	68,7	95,2	2	38	1,05	6310/VA201
	110	27	68,7	95,2	2	38	1,05	6310-2Z/VA201
	110	27	68,7	95,2	2	38	1,04	6310-2Z/VA208
	110	27	68,7	95,2	2	38	1,04	6310-2Z/VA228
55	90	18	66,3	81,5	1,1	21,2	0,38	6011-2Z/VA208
	100	21	69	89,4	1,5	29	0,61	6211/VA201
	100	21	69	89,4	1,5	29	0,61	6211-2Z/VA201
	100	21	69	89,4	1,5	29	0,59	6211-2Z/VA208
	100	21	69	89,4	1,5	29	0,59	6211-2Z/VA228
	120	29	75,3	104	2	45	1,35	6311/VA201
120	29	75,3	104	2	45	1,33	6311-2Z/VA208	
60	110	22	75,5	97	1,5	36	0,78	6212/VA201
	110	22	75,5	97	1,5	36	0,78	6212-2Z/VA201
	110	22	75,5	97	1,5	36	0,74	6212-2Z/VA208
	110	22	75,5	97	1,5	36	0,74	6212-2Z/VA228
	130	31	81,8	113	2,1	52	1,70	6312/VA201
	130	31	81,8	113	2,1	52	1,60	6312-2Z/VA208
65	120	23	83,3	106	1,5	40,5	0,99	6213/VA201
	120	23	83,3	106	1,5	40,5	0,94	6213-2Z/VA208
	120	23	83,3	106	1,5	40,5	0,94	6213-2Z/VA228
	140	33	88,3	122	2,1	60	2,10	6313/VA201
	140	33	88,3	122	2,1	60	2,00	6313-2Z/VA208
70	125	24	87	111	1,5	45	1,05	6214/VA201
	125	24	87	111	1,5	45	1,00	6214-2Z/VA208
	150	35	94,9	130	2,1	68	2,50	6314/VA201
	150	35	94,9	130	2,1	68	2,70	6314-2Z/VA208

Dimensions						Basic static load rating C_0	Mass	Designation	
d	D	B	d_1 ~	D_2 ~	$r_{1,2}$ min				
mm						kN	kg	–	
75	130	25	92	117	1,5	49	1,20	6215/VA201	
	130	25	92	117	1,5	49	1,20	6215-2Z/VA201	
	130	25	92	117	1,5	49	1,15	6215-2Z/VA208	
	130	25	92	117	1,5	49	1,15	6215-2Z/VA228	
	160	37	101	139	2,1	76,5	3,00	6315/VA201	
	160	37	101	139	2,1	76,5	3,00	6315-2Z/VA208	
	80	140	26	101	127	2	55	1,35	6216-2Z/VA208
		170	39	108	147	2,1	86,5	3,55	6316-2Z/VA208
85	150	28	106	135	2	64	1,80	6217/VA201	
	150	28	106	135	2	64	1,70	6217-2Z/VA208	
90	160	30	112	143	2	73,5	2,15	6218-2Z/VA228	
95	170	32	118	152	2,1	81,5	2,60	6219/VA201	
	170	32	118	152	2,1	81,5	2,60	6219-2Z7VA201	
	170	32	118	152	2,1	81,5	2,45	6219-2Z/VA228	
100	150	24	115	139	1,5	54	1,10	6020-2Z/VA208	
	180	34	124	160	2,1	93	3,15	6220/VA201	
	180	34	124	160	2,1	93	3,00	6220-2Z/VA208	
	180	34	124	160	2,1	93	3,00	6220-2Z/VA228	
120	180	28	139	166	2	80	1,90	6024-2Z/VA208	

**Y-bearings for high temperatures
with grub screw locking for metric shafts
d 20 – 60 mm**

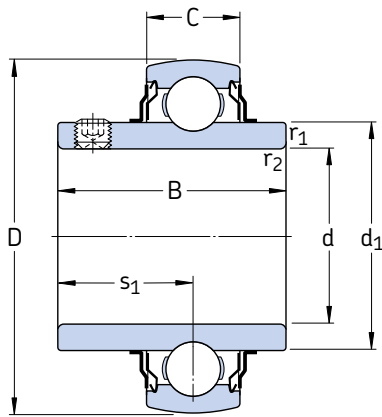

VA201

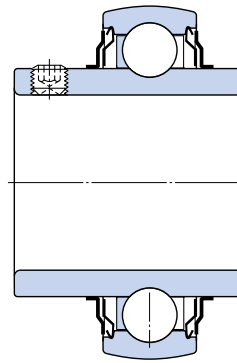

VA228

Dimensions							Basic static load rating C_0	Mass	Designations	
d	D	B	C	d_1	s_1	$r_{1,2}$ min			Bearing with pressed steel cage	one-piece "coronet" cage of graphite
mm							kN	kg	–	
20	47	31	14	28,2	18,3	0,6	6,55	0,14	YAR 204-2FW/VA201	YAR 204-2FW/VA228
25	52	34,1	15	33,7	19,8	0,6	7,8	0,17	YAR 205-2FW/VA201	YAR 205-2FW/VA228
30	62	38,1	18	39,7	22,2	0,6	11,2	0,28	YAR 206-2FW/VA201	YAR 206-2FW/VA228
35	72	42,9	19	46,1	25,4	1	15,3	0,41	YAR 207-2FW/VA201	YAR 207-2FW/VA228
40	80	49,2	21	51,8	30,2	1	19	0,55	YAR 208-2FW/VA201	YAR 208-2FW/VA228
45	85	49,2	22	56,8	30,2	1	21,6	0,60	YAR 209-2FW/VA201	YAR 209-2FW/VA228
50	90	51,6	22	62,5	32,6	1	23,2	0,69	YAR 210-2FW/VA201	YAR 210-2FW/VA228
55	100	55,6	25	69,1	33,4	1	29	0,94	YAR 211-2FW/VA201	YAR 211-2FW/VA228
60	110	65,1	26	75,6	39,7	1,5	36	1,30	YAR 212-2FW/VA201	YAR 212-2FW/VA228

**Y-bearings for high temperatures
with grub screw locking for inch shafts**
d 3/4 – 2 7/16 in

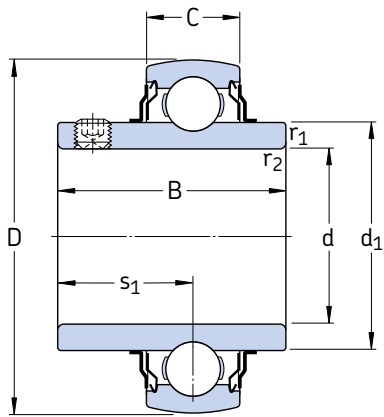

VA201

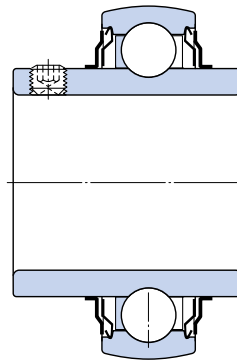

VA228

Dimensions							Basic static load rating C_0	Mass	Designations	
d	D	B	C	d_1	s_1	$r_{1,2}$ min			Bearing with pressed steel cage	one-piece "coronet" cage of graphite
in	mm						kN	kg	–	
3/4	47	31	14	28,2	18,3	0,6	6,55	0,14	YAR 204-012-2FW/VA201	YAR 204-012-2FW/VA228
1	52	34,1	15	33,7	19,8	0,6	7,8	0,17	YAR 205-100-2FW/VA201	YAR 205-100-2FW/VA228
1 3/16	62	38,1	18	39,7	22,2	0,6	11,2	0,27	YAR 206-103-2FW/VA201	YAR 206-103-2FW/VA228
1 1/4	72	42,9	19	46,1	25,4	1	15,3	0,46	YAR 207-104-2FW/VA201	YAR 207-104-2FW/VA228
1 7/16	72	42,9	19	46,1	25,4	1	15,3	0,38	YAR 207-107-2FW/VA201	YAR 207-107-2FW/VA228
1 1/2	80	49,2	21	51,8	30,2	1	19	0,59	YAR 208-108-2FW/VA201	YAR 208-108-2FW/VA228
1 11/16	85	49,2	22	56,8	30,2	1	21,6	0,66	YAR 209-111-2FW/VA201	YAR 209-111-2FW/VA228
1 3/4	85	49,2	22	56,8	30,2	1	21,6	0,62	YAR 209-112-2FW/VA201	YAR 209-112-2FW/VA228
1 15/16	90	51,6	22	62,5	32,6	1	23,2	0,71	YAR 210-115-2FW/VA201	YAR 210-115-2FW/VA228
2	100	55,6	25	69,1	33,4	1	29	0,94	YAR 211-200-2FW/VA201	YAR 211-200-2FW/VA228
2 3/16	100	55,6	25	69,1	33,4	1	29	0,92	YAR 211-203-2FW/VA201	YAR 211-203-2FW/VA228
2 7/16	110	65,1	26	75,6	39,7	1,5	36	1,30	YAR 212-207-2FW/VA201	YAR 212-207-2FW/VA228

**Y-bearing plummer (pillow) block units
for high temperatures and metric shafts
d 20 – 60 mm**

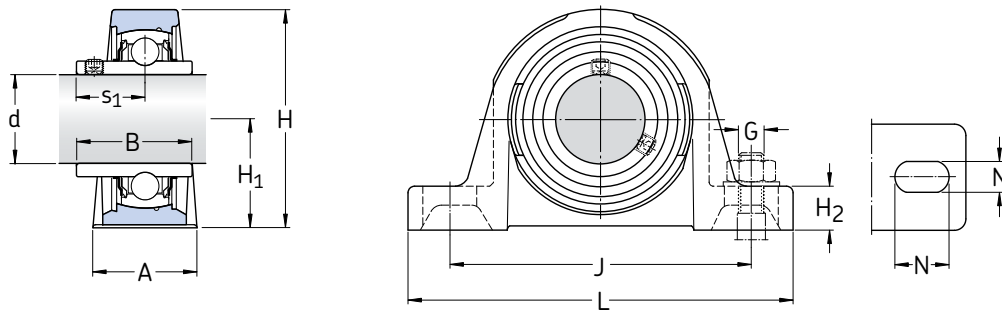

Dimensions													Basic static load rating C ₀	Mass	Designations	
d	A	B	H	H ₁	H ₂	J	L	N	N ₁	G	s ₁	Y-bearing unit with pressed steel cage			one-piece "coronet" cage of graphite	
mm													kN	kg	–	
20	32	31	64	33,3	14	97	127	20,5	11,5	10	18,3	6,55	0,57	SY 20 TF/VA201	SY 20 TF/VA228	
25	36	34,1	70	36,5	16	102	130	19,5	11,5	10	19,8	7,8	0,73	SY 25 TF/VA201	SY 25 TF/VA228	
30	40	38,1	82	42,9	16,5	117,5	152	23,5	14	12	22,2	11,2	1,10	SY 30 TF/VA201	SY 30 TF/VA228	
35	45	42,9	93	47,6	19	126	160	21	14	12	25,4	15,3	1,45	SY 35 TF/VA201	SY 35 TF/VA228	
40	48	49,2	99	49,2	19	135,5	175	24,5	14	12	30,2	19	1,80	SY 40 TF/VA201	SY 40 TF/VA228	
45	48	49,2	107	54	20,6	143,5	187	22,5	14	12	30,2	21,6	2,20	SY 45 TF/VA201	SY 45 TF/VA228	
50	54	51,6	114	57,2	22	157	203	26	18	16	32,6	23,2	2,70	SY 50 TF/VA201	SY 50 TF/VA228	
55	60	55,6	127	63,5	23,8	171,5	219	27,5	18	16	33,4	29	3,60	SY 55 TF/VA201	SY 55 TF/VA228	
60	60	65,1	139,7	69,9	26	190,5	240	29	18	16	39,7	36	4,45	SY 60 TF/VA201	SY 60 TF/VA228	

**Y-bearing plummer (pillow) block units
for high temperatures and inch shafts**
d $\frac{3}{4}$ – $2 \frac{7}{16}$ in

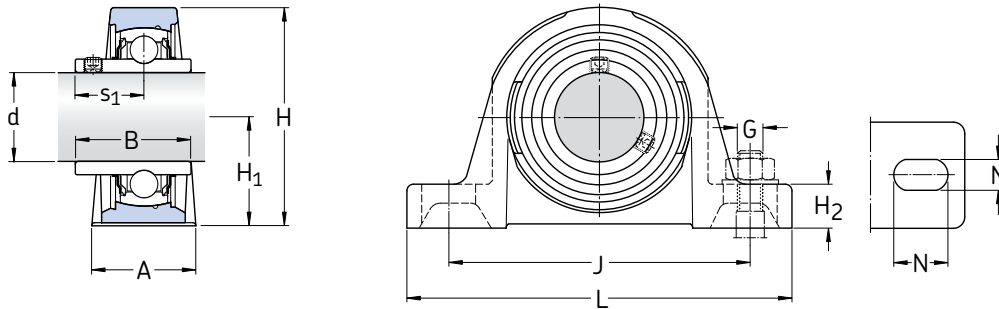

Dimensions											Basic static load rating C_0	Mass kg	Designations		
d	A	B	H	H_1	H_2	J	L	N	N_1	G			s_1	Y-bearing unit with pressed steel cage	one-piece "coronet" cage of graphite
in	mm										kN	kg	–		
$\frac{3}{4}$	32	31	64	33,3	14	97	127	20,5	11,5	10	18,3	6,55	0,57	SY 3/4 TF/VA201	SY 3/4 TF/VA228
1	36	34,1	70	36,5	16	102	130	19,5	11,5	10	19,8	7,8	0,73	SY 1. TF/VA201	SY 1. TF/VA228
1 $\frac{3}{16}$	40	38,1	82	42,9	17	117,5	152	23,5	14	12	22,2	11,2	1,10	SY 1.3/16 TF/VA201	SY 1.3/16 TF/VA228
1 $\frac{1}{4}$	45	42,9	93	47,6	19	126	160	21	14	12	25,4	15,3	1,45	SY 1.1/4 TF/VA201	SY 1.1/4 TF/VA228
1 $\frac{7}{16}$	45	42,9	93	47,6	19	126	160	21	14	12	25,4	15,3	1,45	SY 1.7/16 TF/VA201	SY 1.7/16 TF/VA228
1 $\frac{1}{2}$	48	49,2	99	49,2	19	135,5	175	24,5	14	12	30,2	19	1,80	SY 1.1/2 TF/VA201	SY 1.1/2 TF/VA228
1 $\frac{11}{16}$	48	49,2	107	54	20,6	143,5	187	22,5	14	12	30,2	21,6	2,2	SY 1.11/16 TF/VA201	SY 1.11/16 TF/VA228
1 $\frac{3}{4}$	48	49,2	107	54	20,6	143,5	187	22,5	14,5	12	30,2	21,6	2,20	SY 1.3/4 TF/VA201	SY 1.3/4 TF/VA228
1 $\frac{15}{16}$	54	51,6	114	57,2	22	157	203	26	18	16	32,6	23,2	2,70	SY 1.15/16 TF/VA201	SY 1.15/16 TF/VA228
2	60	55,6	127	63,5	23,8	171,5	219	27,5	18	16	33,4	29	3,60	SY 2. TF/VA201	SY 2. TF/VA228
2 $\frac{3}{16}$	60	55,6	127	63,5	23,8	171,5	219	27,5	18	16	33,4	29	3,55	SY 2.3/16 TF/VA201	SY 2.3/16 TF/VA228
2 $\frac{7}{16}$	60	65,1	139,7	69,9	26	190,5	240	29	18	16	39,7	36	4,45	SY 2.7/16 TF/VA201	SY 2.7/16 TF/VA228

**Y-bearing flanged units with square housing
for high temperatures and metric shafts
d 20 – 60 mm**

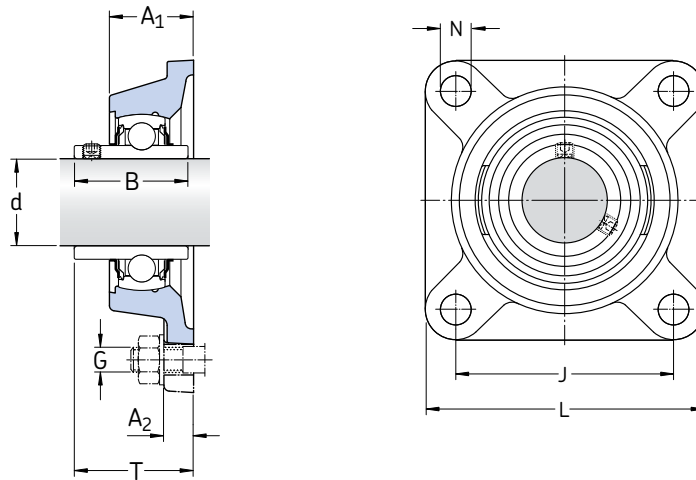

Dimensions									Basic static load rating C_0	Mass	Designations	
d	A_1	A_2	B	J	L	N	G	T			Y-bearing unit with pressed steel cage	one-piece "coronet" cage of graphite
mm									kN	kg	–	
20	29,5	11	31	63,5	86	11,1	10	37,3	6,55	0,60	FY 20 TF/VA201	FY 20 TF/VA228
25	30	12	34,1	70	95	12,7	10	38,8	7,8	0,77	FY 25 TF/VA201	FY 25 TF/VA228
30	32,5	13	38,1	82,5	108	12,7	10	42,2	11,2	1,10	FY 30 TF/VA201	FY 30 TF/VA228
35	34,5	13	42,9	92	118	14,3	12	46,4	15,3	1,40	FY 35 TF/VA201	FY 35 TF/VA228
40	38,5	14	49,2	101,5	130	14,3	12	54,2	19	1,90	FY 40 TF/VA201	FY 40 TF/VA228
45	39	14	49,2	105	137	15,9	14	54,2	21,6	2,10	FY 45 TF/VA201	FY 45 TF/VA228
50	43	15	51,6	111	143	15,9	14	60,6	23,2	2,50	FY 50 TF/VA201	FY 50 TF/VA228
55	47,5	16	55,6	130	162	19	16	64,4	29	3,60	FY 55 TF/VA201	FY 55 TF/VA228
60	52	17	65,1	143	175	19	16	73,7	36	4,60	FY 60 TF/VA201	FY 60 TF/VA228

**Y-bearing flanged units with square housing
for high temperatures and inch shafts**
d 3/4 – 2 7/16 in

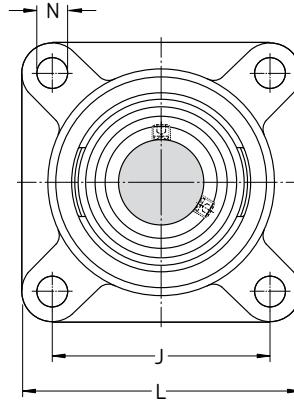
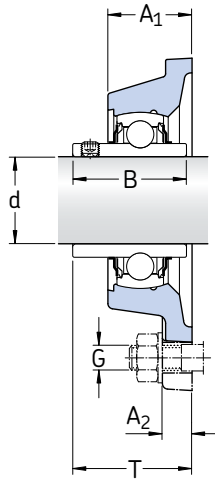

Dimensions									Basic static load rating C ₀	Mass	Designations Y-bearing unit with pressed steel cage	one-piece "coronet" cage of graphite
d	A ₁	A ₂	B	J	L	N	G	T				
in	mm								kN	kg	–	
3/4	29,5	11	31	63,5	86	11,1	10	37,3	6,55	0,60	FY 3/4 TF/VA201	FY 3/4 TF/VA228
1	30	12	34,1	70	95	12,7	10	38,8	7,8	0,77	FY 1. TF/VA201	FY 1. TF/VA228
1 3/16	32,5	13	38,1	82,5	108	12,7	10	42,2	11,2	1,10	FY 1.3/16 TF/VA201	FY 1.3/16 TF/VA228
1 1/4	34,5	13	42,9	92	118	14,3	12	46,4	15,3	1,40	FY 1.1/4 TF/VA201	FY 1.1/4 TF/VA228
1 7/16	34,5	13	42,9	92	118	14,3	12	46,4	15,3	1,40	FY 1.7/16 TF/VA201	FY 1.7/16 TF/VA228
1 1/2	38,5	14	49,2	101,5	130	14,3	12	54,2	19	1,90	FY 1.1/2 TF/VA201	FY 1.1/2 TF/VA228
1 11/16	39	14	49,2	105	137	15,9	14	54,2	21,6	2,10	FY 1.11/16 TF/VA201	FY 1.11/16 TF/VA228
1 3/4	39	14	49,2	105	137	15,9	14	54,2	21,6	2,10	FY 1.3/4 TF/VA201	FY 1.3/4 TF/VA228
1 15/16	43	15	51,6	111	143	15,9	14	60,6	23,2	2,50	FY 1.15/16 TF/VA201	FY 1.15/16 TF/VA228
2	47,5	16	55,6	130	162	19	16	64,4	29	3,75	FY 2. TF/VA201	FY 2. TF/VA228
2 3/16	47,5	16	55,6	130	162	19	16	64,4	29	3,70	FY 2.3/16 TF/VA201	FY 2.3/16 TF/VA228
2 7/16	52	17	65,1	143	175	19	16	73,7	36	4,50	FY 2.7/16 TF/VA201	FY 2.7/16 TF/VA228

**Y-bearing flanged units with oval housing
for high temperatures and metric shafts
d 20 – 55 mm**

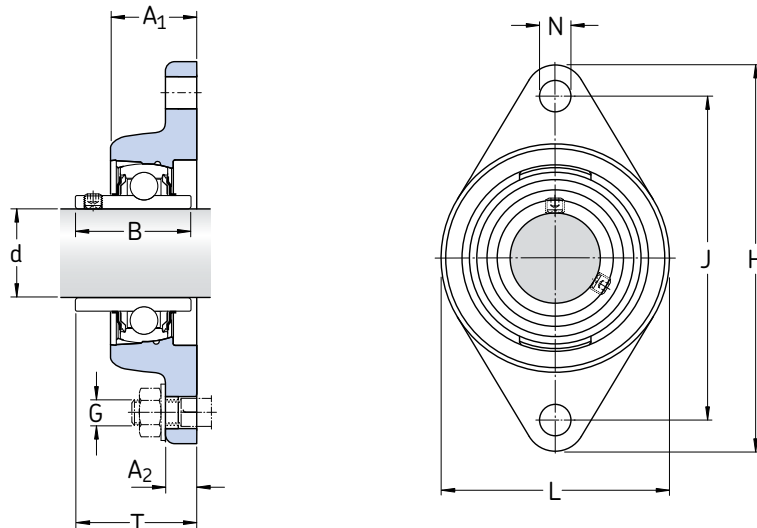

Dimensions										Basic static load rating C_0	Mass	Designations	
d	A_1	A_2	B	H	J	L	N	G	T			Y-bearing unit with pressed steel cage	one-piece "coronet" cage of graphite
mm										kN	kg	–	
20	24,6	11	31	112	89,7	60,3	11,1	10	32,6	6,55	0,50	FYT 20 TF/VA201	FYT 20 TF/VA228
25	30	12	34,1	124	98,9	70	12,7	10	38,8	7,8	0,63	FYT 25 TF/VA201	FYT 25 TF/VA228
30	32,5	13	38,1	141,5	116,7	83	12,7	10	42,2	11,2	0,93	FYT 30 TF/VA201	FYT 30 TF/VA228
35	34,5	13	42,9	156	130,2	96	14,3	12	46,4	15,3	1,25	FYT 35 TF/VA201	FYT 35 TF/VA228
40	38,5	14	49,2	171,5	143,7	102	14,3	12	54,2	19	1,65	FYT 40 TF/VA201	FYT 40 TF/VA228
45	39	14	49,2	178,5	148,5	111	15,9	14	54,2	21,6	1,80	FYT 45 TF/VA201	FYT 45 TF/VA228
50	43	15	51,6	189	157,2	116	15,9	14	60,6	23,2	2,15	FYT 50 TF/VA201	FYT 50 TF/VA228
55	47,6	20,6	55,6	215,9	184,2	127	19	16	62,8	29	3,30	FYT 55 TF/VA201	FYT 55 TF/VA228

**Y-bearing flanged units with oval housing
for high temperatures and inch shafts**
d $\frac{3}{4}$ – $2 \frac{3}{16}$ in

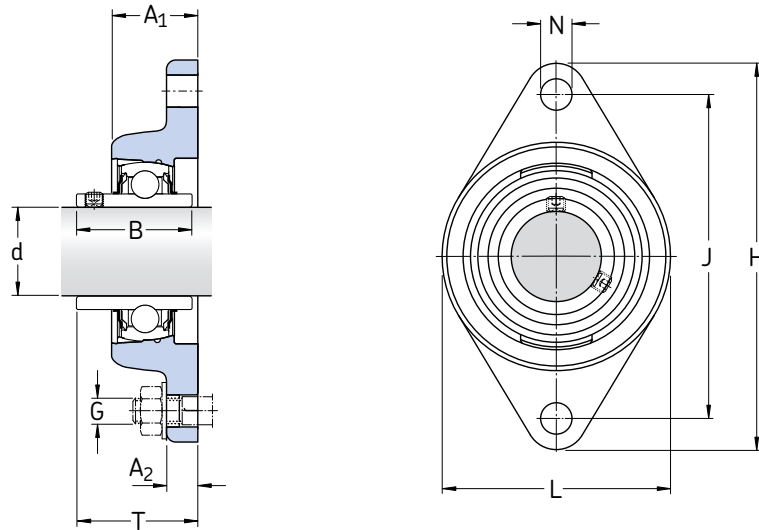

Dimensions										Basic static load rating C_0	Mass	Designations Y-bearing unit with pressed steel cage	one-piece "coronet" cage of graphite
d	A ₁	A ₂	B	H	J	L	N	G	T				
in	mm									kN	kg	–	
$\frac{3}{4}$	24,6	11	31	112	89,7	60,5	11,1	10	32,6	6,55	0,50	FYT $\frac{3}{4}$ TF/VA201	FYT $\frac{3}{4}$ TF/VA228
1	30	12	34,1	124	98,9	70	12,7	10	38,8	7,8	0,63	FYT 1. TF/VA201	FYT 1. TF/VA228
$1 \frac{3}{16}$	32,5	13	38,1	141,5	116,7	83	12,7	10	42,2	11,2	0,93	FYT $1.3/16$ TF/VA201	FYT $1.3/16$ TF/VA228
$1 \frac{1}{4}$	34,5	13	42,9	156	130,2	96	14,3	12	46,4	15,3	1,25	FYT $1.1/4$ TF/VA201	FYT $1.1/4$ TF/VA228
$1 \frac{7}{16}$	34,5	13	42,9	156	130,2	96	14,3	12	46,4	15,3	1,20	FYT $1.7/16$ TF/VA201	FYT $1.7/16$ TF/VA228
$1 \frac{1}{2}$	38,5	14	49,2	171,5	143,7	102	14,3	12	54,2	19	1,65	FYT $1.1/2$ TF/VA201	FYT $1.1/2$ TF/VA228
$1 \frac{11}{16}$	39	14	49,2	178,5	148,5	111	15,9	14	54,2	21,6	1,80	FYT $1.11/16$ TF/VA201	FYT $1.11/16$ TF/VA228
$1 \frac{3}{4}$	39	14	49,2	178,5	148,5	111	15,9	14	54,2	21,6	1,80	FYT $1.3/4$ TF/VA201	FYT $1.3/4$ TF/VA228
$1 \frac{15}{16}$	43	15	51,6	189	157,2	116	15,9	14	60,6	23,2	2,15	FYT $1.15/16$ TF/VA201	FYT $1.15/16$ TF/VA228
2	47,6	20,6	55,6	215,9	184,2	127	19	16	62,8	29	3,30	FYT 2. TF/VA201	FYT 2. TF/VA228
$2 \frac{3}{16}$	47,6	20,6	55,6	215,9	184,2	127	19	16	62,8	29	3,25	FYT $2.3/16$ TF/VA201	FYT $2.3/16$ TF/VA228



NoWear[®] bearings

NoWear bearings	944
NoWear bearings of L5DA execution	944
NoWear bearings of L7DA execution	944
Applications of NoWear bearings	946
NoWear service life improvement	946
Bearing data – general	946
Dimensions, tolerances, internal clearance	946
Load carrying capacity	946
NoWear coating material	947
NoWear bearing lubrication	947

NoWear bearings

In this day and age where productivity means higher speeds, higher operational temperatures and reduced maintenance, bearings are expected to exceed the bounds of former possibilities. New and advanced applications are setting higher demands on bearings, especially under extreme operating conditions, where there is the risk of smearing, boundary lubrication, sudden load variations, low loads or high operational temperatures.

To withstand these types of severe operating conditions SKF bearings can be furnished with a low friction ceramic coating on the contact surfaces inside the bearing. This coating, trademarked NoWear, was developed by SKF for rolling bearings and is covered by an SKF patent.

NoWear bearings

NoWear bearings make sense whenever bearings are failing prematurely due to severe operating conditions. NoWear bearings can withstand longer periods of insufficient lubrication, sudden variations in load and rapid speed changes, vibrations and oscillations.

NoWear bearings open up new possibilities to existing applications operating under severe conditions, without introducing major design changes and enable freedom in new designs. They have already been proven in a wide range of extreme applications, including paper machines, marine and offshore applications, fans, compressors, hydraulic pumps and motors.

Most SKF ball and roller bearings can be obtained in a NoWear execution as described below and shown in **table 1**. Other executions might be available on request.

NoWear bearings of L5DA execution

NoWear bearings of the L5DA execution are the most commonly used bearings. These NoWear bearings are equipped with coated rolling elements (→ **fig. 1**) and are recommended for applications where the bearing load is low to medium, or where vibrations and oscillations are present.

Fig. 1



Fig. 2



NoWear bearings of L7DA execution

NoWear bearings of the L7DA execution have the coating applied to the rolling elements and the inner ring raceway(s) (→ **fig. 2**). This execution is recommended for applications where abrasive wear resistance is crucial or load is heavy.

Table 1

NoWear bearing product range			
Bearing type Symbol	Range ¹⁾	Available bearing execution	
		Coated rolling elements	Coated rolling elements + inner ring raceway(s)
	Deep groove ball bearings – bore diameter range $d = 15 - 140$ mm	L5DA	L7DA
	Angular contact ball bearings – bore diameter range $d = 15 - 140$ mm	L5DA	L7DA
	Cylindrical roller bearings – bore diameter range $d = 15 - 220$ mm – bore diameter range d over 220 mm	L5DA L5DA	L7DA –
	Needle roller bearings – bore diameter range $d = 15 - 220$ mm – bore diameter range d over 220 mm	L5DA L5DA	L7DA –
	Spherical roller bearings – bore diameter range $d = 15 - 220$ mm – bore diameter range d over 220 mm	L5DA L5DA	L7DA –
	CARB toroidal roller bearings – bore diameter range $d = 15 - 220$ mm – bore diameter range d over 220 mm	L5DA L5DA	L7DA –
	Thrust ball bearings – bore diameter range $d = 15 - 110$ mm	L5DA	–
	Spherical roller thrust bearings – complete bore diameter range	L5DA	–

¹⁾ These ranges are general guidelines and may vary between dimension series. Please contact SKF for details

Applications of NoWear bearings

For highly demanding applications where NoWear bearings are to be used, normally several operating parameters must be considered and weighted against each other. As a result, NoWear coated bearings should be selected in close cooperation with the SKF application engineering service.

The following recommendations are intended to illustrate the types of application that can benefit from the NoWear executions.

When cylindrical roller, needle roller, spherical roller or toroidal roller bearings are subjected to low loads in combination with high speeds, L5DA NoWear bearings are recommended in cases where the calculated bearing life cannot be reached.

With the L5DA execution of the NoWear bearings extended relubrication intervals are possible without negatively influencing bearing service life. However, if relubrication intervals are maintained, operating speeds can be increased.

Bearings subjected to oscillations or external vibrations can fail prematurely due to insufficient lubrication. Under these conditions, SKF recommends the L5DA execution. However, in extreme cases, the L7DA execution may be preferred.

If operating conditions cause low operating viscosity ($\kappa < 1$) and no appropriate lubricants are available, NoWear bearings are an excellent way to extend bearing life and to achieve operational reliability. The L5DA execution of the NoWear bearings is normally recommended. However, for unusual lubrication conditions, for example when the bearings are to be lubricated by the process media, the more advanced L7DA execution should be used.

For additional information about the NoWear bearings please consult the SKF application engineering service.

NoWear service life improvement

NoWear bearings are suitable in situations where lubricating film is insufficient for undisturbed bearing operation, i.e. when κ is below 1. To calculate life of a NoWear bearing, the traditional bearing life calculation should be used but with $\kappa = 1$.

Improvement in service life by switching to NoWear under low load and high-speed conditions depends on the application, but experience shows a multifold improvement should be expected. However, calculating service life under these conditions is difficult.

For grease lubricated bearings running at speeds near or above bearing speed rating, or at high temperatures shortening grease life, selecting NoWear execution prolong relubrication intervals up to 15 times depending on application conditions.

When extension of service life would be desirable in applications with heavy loads and marginal lubrication, NoWear can be a solution. The NoWear coating cannot protect the bearing against spalling as a result of constant heavy loads. At heavy loads the maximum shear stresses are located below the coating within the bearing steel, which still has the properties of normal steel. For such applications, contact SKF.

Bearing data – general

Dimensions, tolerances, internal clearance

Dimensions, tolerances and internal clearance of NoWear bearings are the same as for standard bearings.

Load carrying capacity

The basic dynamic and static load ratings for NoWear bearings are the same as for standard bearings.

NoWear coating material

A physical vapour deposition process applies the low friction, ceramic coating. Bearing surfaces coated in this way have all the resilience of the underlying material, but with the hardness, low friction coefficient and wear resistance of the NoWear coating. During operation there will be some micro level transfer of the coating material to the counter surface. Such transfer plus the inertness of the material reduce friction and improve resistance against wear and smearing, even for bearings where only the rolling elements are coated.

The essential properties of the NoWear coating are listed in **table 2**.

NoWear bearing lubrication

As default, the same lubrication guidelines are valid for NoWear bearings as for standard bearings (→ section “Lubrication”, starting on **page 229**). However, NoWear bearings will operate with high reliability, even when adequate surface separation cannot be achieved ($\kappa < 1$), by preventing direct metal-to-metal contact between rolling elements and rings. It should be noted that it might be possible to reduce EP and AW additives in the lubricant with the NoWear coating, as the coating already acts as a powerful additive.

NoWear bearings are not intended for vacuum or other completely dry running applications.

Table 2

Properties of NoWear coating	
Properties	NoWear
Hardness	1 200 HV10
Coating thickness – depending on bearing size (µm)	1 ... 3
Coefficient of friction – dry sliding against steel	0,1 ... 0,2
Operating temperature range¹⁾ – NoWear coating	+350 °C

¹⁾ NoWear coating withstands temperatures up to +350 °C. However, most times the bearing steel is the limiting factor. Please contact the SKF application engineering service for more information



Bearings and bearing units with Solid Oil

Bearings and bearing units with Solid Oil	950
Features of Solid Oil	951
Bearing data – general	952
Dimensions, tolerances, internal clearance	952
Load carrying capacity	952
Minimum load.....	952
Limiting speeds	952
Oil properties	953

Bearings with Solid Oil

In most applications, ordinary greases and lubricating oils will provide satisfactory lubrication to the bearing giving it an acceptable service life. However, there may be cases where lack of accessibility means that relubrication is virtually impossible, or where very good contaminant exclusion is required. Solid Oil – the third choice of lubrication – may be the answer, as it provides “lubrication for life” and good sealing.

Solid Oil has been very beneficial in outdoor lifting equipment, cranes and traverses, and in vertical shaft arrangements or where bearing arrangements cannot be reached for relubrication.

Bearings and bearing units with Solid Oil

Most SKF ball and roller bearings as well as bearing units (→ **fig. 1**) can be supplied with Solid Oil and are identified by the designation suffix W64.

Bearings fitted with large-volume cages made of polyamide or machined brass are less suitable for Solid Oil. This also is the case with CARB toroidal roller bearings, which will lose their axial displacement properties when filled with Solid Oil.

Fig. 1



Features of Solid Oil

Solid Oil consists of a polymer matrix, which is saturated with lubricating oil.

The polymer material has a structure with millions of micro-pores, which hold the lubricating oil. The pores are so small that the oil is retained in the material by surface tension. Oil represents an average of 70 % by weight of the material.

The oil used as standard is very high quality synthetic oil, which meets the needs of most applications.

The oil-filled polymer material is moulded into the bearing. A very narrow gap will form around the rolling elements and raceways during the moulding process, enabling the bearing components to rotate freely. The oil, which seeps into the gap, provides good lubrication for the bearing right from the start. Solid Oil completely fills the internal space in a bearing and encapsulates the cage and rolling elements. Solid Oil uses the cage as a reinforcement element and rotates with it.

Solid Oil keeps the oil in position and brings more oil to the bearing than grease. A metallic surface sliding against Solid Oil is provided with an even and consistent oil film. A moderate increase in temperature causes oil to be pushed towards the surface of the polymer matrix, as the thermal expansion of the oil is greater than that of the polymer matrix. The viscosity of the oil also decreases with increasing temperature. When the bearing stops running, the polymer matrix reabsorbs excess oil.

In addition, Solid Oil is environmentally friendly and keeps contaminants out of the bearing, even without seals (→ **fig. 2**). However, for those applications where very good contamination exclusion is needed, the use of bearings with Solid Oil and integral contact seals is recommended. But in all cases maintenance will be unnecessary because no relubrication is needed.

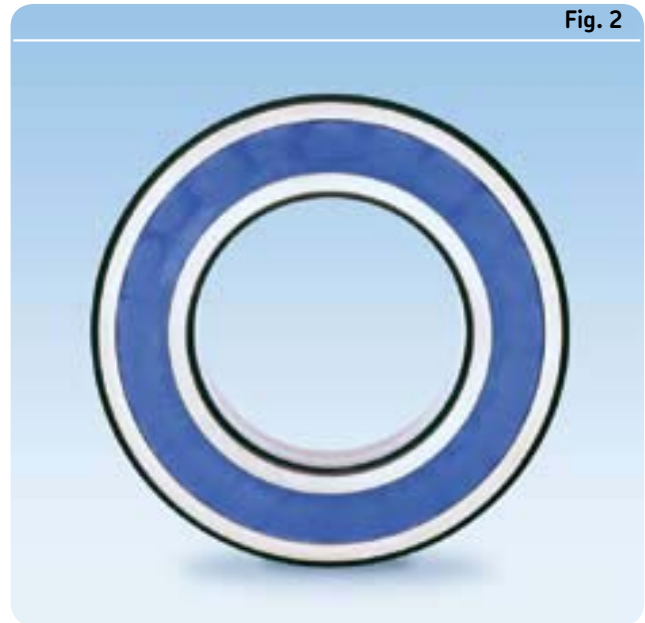

Bearing data – general

Dimensions, tolerances, internal clearance

Dimensions, tolerances and internal clearance of bearings or units with Solid Oil are the same as for the corresponding standard products.

Load carrying capacity

The basic dynamic and static load ratings for the Solid Oil bearings are the same as for the corresponding standard bearings.

Minimum load

In order to provide satisfactory operation, bearings or units with Solid Oil, like all bearings or units, must always be subjected to a given minimum load, which should be slightly higher than for the standard bearings or units. The recommendations for calculating the requisite minimum loads for the different standard bearing types are provided in the text preceding each table section.

Limiting speeds

An indication of the limiting speeds for bearings with Solid Oil is provided in **table 1** by the speed factor

$$A = n d_m$$

where

A = speed factor mm/min

n = rotational speed, r/min

d_m = bearing mean diameter
= 0,5 (d + D), mm

The speed limits indicated by the factor A apply to open (unsealed) bearings. For bearings with integral seals 80 % of the quoted values should be used.

It is important to remember that the higher the speed, the higher the operating temperature. It may therefore be necessary to limit the bearing speed for high temperature operation so that the temperature limit for the Solid Oil is not exceeded.

Generally, when bearings with Solid Oil are to operate under extreme conditions, it is advisable

Table 1

Limiting speeds	
Bearing type	Speed factor A
Deep groove ball bearings	
– single row	300 000
– double row	40 000
Angular contact ball bearings	
– with pressed steel cage	150 000
– with polyamide 6,6 cage	40 000
Self-aligning ball bearings	
– with pressed steel cage	150 000
– with polyamide 6,6 cage	40 000
Cylindrical roller bearings	
– with pressed steel cage	150 000
– with polyamide 6,6 cage	40 000
Taper roller bearings	45 000
Spherical roller bearings	
– E design	42 500
– CC design	85 000
Y-bearings, Y-bearing units	40 000

to contact the SKF application engineering service for advice and support.

Oil properties

The standard oil normally used for Solid Oil is a very high quality synthetic oil. Its important properties are listed in **table 2**.

Oils having other viscosities can also be used successfully, e.g. special oils for the food industry, heavily loaded or low temperature applications etc. Additives, such as rust inhibitors, can be added to Solid Oil to provide extra protection. Before deciding upon oil type and ordering, please consult the SKF application engineering service.

Table 2

Standard oil for Solid Oil	
Properties	Solid Oil
Kinematic viscosity at 40 °C at 100 °C	140 mm ² /s 19 mm ² /s
Permissible temperatures¹⁾ – for continuous operations – for intermittent operations – for start-up operations	+85 °C +95 °C –40 °C

¹⁾ Bearings with Solid Oil can be heated for mounting purposes up to +100 °C

Mechatronics

Sensor-Bearing Units.....	957
Steer-By-Wire Modules.....	967
Mast Height Control units.....	969
Other sensorized units	971





Sensor-Bearing Units

SKF Sensor-Bearing Units	958
SKF Explorer class deep groove ball bearings.....	959
SKF active sensor units	959
Unit data – general.....	960
Design	960
Dimensions.....	960
Bearing tolerances	961
Bearing internal clearance.....	961
Permissible speeds.....	961
Temperature range.....	961
Electrical interface data	961
Electro-magnetic compatibility	961
Selection of Sensor-Bearing size	962
Application of Sensor-Bearing units	962
Radial location	962
Axial location.....	962
Mounting.....	963
Lubrication and maintenance	963
Product table	964

Sensor-Bearing Units

Exact information on the motion status of rotating or axially travelling components is decisive in many fields of engineering. Exact motion control becomes all the more important with the increasing necessity of automation of all kinds of processes. In addition, the demand to design more light-weight and simpler constructions calls for integral system solutions (→ **fig. 1**), e.g. for sensor bearing units to record:

1. the number of revolutions.
2. the speed.
3. the direction of rotation.
4. the relative position/counting.
5. the acceleration or deceleration.

SKF Sensor-Bearing Units

SKF Sensor-Bearing Units (→ **fig. 2**) are mechatronic machine components covering the fields of both sensor and bearing engineering. They are virtually an ideal combination of a versatile ball bearing with a sensor unit shielded from external influences. The sensor body, impulse ring and bearing are mechanically attached to each other, forming an integral ready-to-mount unit.

The SKF designed and patented Sensor-Bearing Units are simple, robust and consist of

- an SKF Explorer class deep groove ball bearing and
- an SKF active sensor unit.

The SKF Sensor-Bearing Units are specially designed to perform as incremental encoders for motor and/or machine control. They are specially adapted to fit asynchronous motors, and provide compact and reliable encoding for their most demanding control. They are intended for applications with rotating inner ring and stationary outer ring. SKF Sensor-Bearing Units for applications with stationary inner ring and rotating outer ring, e.g. for the use in conveyor systems, can be manufactured on request, please contact the SKF application engineering service.

Fig. 1

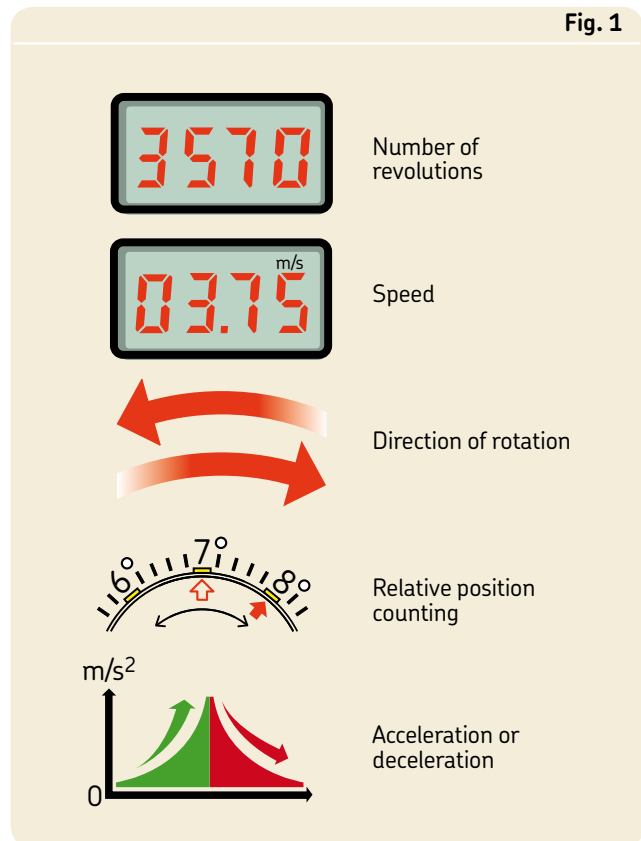
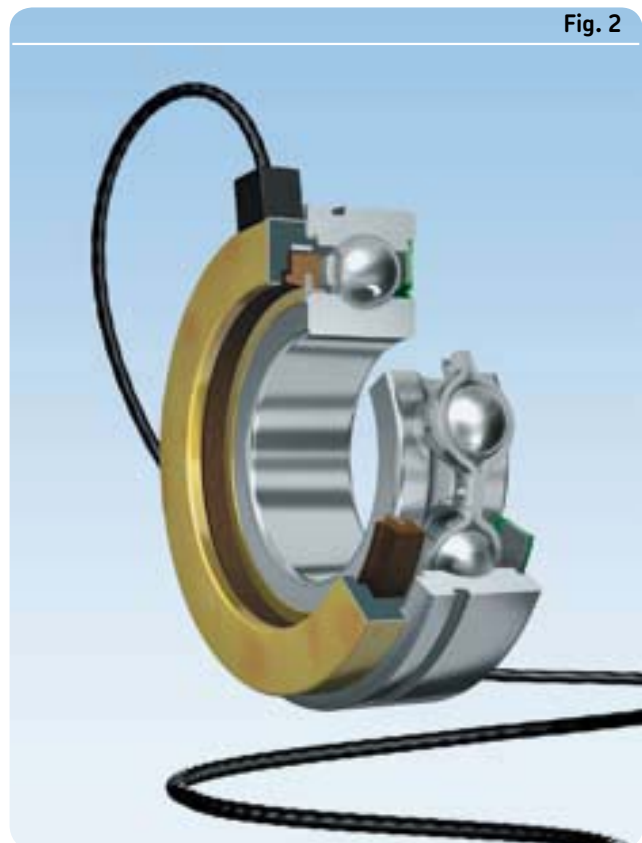

Fig. 2



SKF Explorer class deep groove ball bearings

The single row SKF Explorer deep groove ball bearings are suitable for high speeds and robust in operation. They can accommodate not only rather heavy radial loads, but also axial loads and serve as locating bearings guiding the shaft axially in both directions. Furthermore they are noted for their high manufacturing accuracy, their low noise and friction levels. The efficient sealing and the grease filling provide maintenance-free operation for life.

SKF active sensor units

The SKF Sensor-Bearing Unit incorporates an active sensor designed to be compact and robust, very close to an incremental encoder function. It provides accurate measuring down to zero speed. Its main components are the impulse ring, the sensor body with the sensors and the connecting cable.

The composite magnetized impulse ring is attached to the bearing inner ring. Depending on the bearing size, it is divided into a certain number of north and south poles. The number of pulses per revolution normally ranges between 32 and 80.

The sensor body is attached to the bearing outer ring by an SKF patented solution. The sensor body has two cells, enabling the direction of rotation to be determined. The two sensors are offset to each other in the sensor body. In a small integrated circuit they contain not only the Hall generator as an active element but also the electronics for signal amplification and conversion. The analogue sinusoidal signal generated by the Hall cell is amplified and converted into a square-wave signal by a Schmitt trigger (→ fig. 3). The leading signal determines the direction of rotation.

Furthermore two sensors provide double the number of pulses, e.g. 128 pulses per revolution compared with 64 for a standard bearing. When counting the rising and falling edges of the pulses a maximum accuracy of 256 pulses per revolution can be attained, which corresponds to a resolution of 1,4 angular degrees.

The sensor requires an external voltage supply. The signal output is fed via an open collector circuit.

Fig. 3

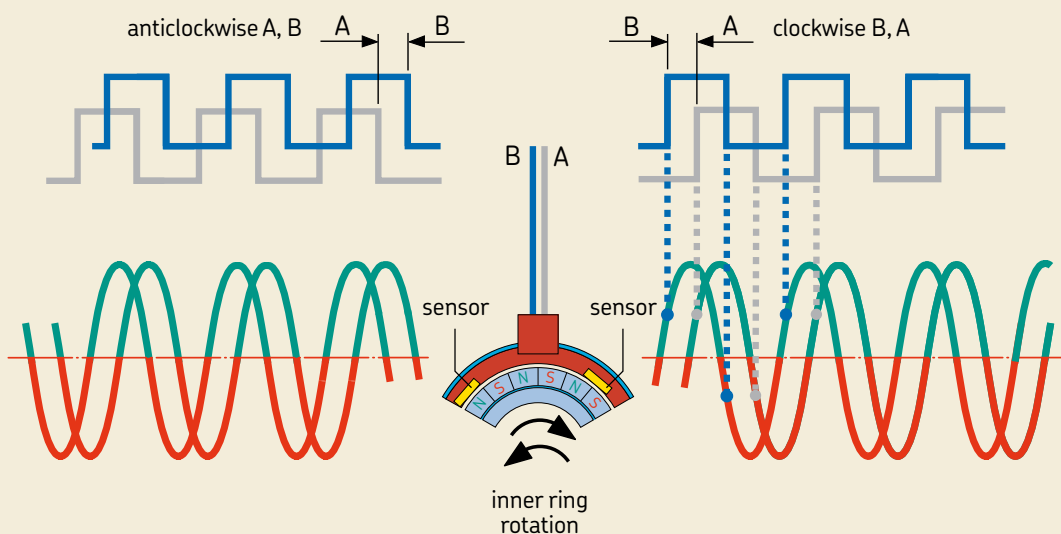

Unit data – general

Design

SKF Sensor-Bearing Units (→ **fig. 4**) consist of

- an SKF Explorer deep groove ball bearing with a RS1 contact seal and a snap ring groove in the outside surface of the outer ring (**a**)
- a magnetized impulse ring (**b**)
- a sensor body (**c**)
- a connecting cable (**d**).

At the side opposite to the seal, the impulse and sensor body form an effective labyrinth seal.

The impulse ring is a composite magnetized ring. The number of north and south poles (between 32 and 80) depends on the bearing size. The impulse ring is attached to the inner ring.

The sensor body protecting two embedded Hall cells is attached to the outer ring – a patented SKF solution. The multi-wire cable extends in the radial direction, connecting the SKF Sensor-Bearing Unit and the signal processing electronics and has a standard length of approximately 500 mm. To account for the different interface requirements between the Sensor-Bearing Unit and the customized electronic unit, SKF Sensor-Bearing Units (→ **fig. 5**) provide the choice of three versions:

- Version 1: Free cable end.
- Version 2: Plug connection AMP Superseal, AMP Nos. 282106-1 and 282404-1.
- Version 3: Plug connection AMP Mate-N-Lock, AMP Nos. 350779-1, 350811-1 and 350924-1.

Dimensions

SKF Sensor-Bearing Units are based on SKF Explorer class deep groove ball bearings in the 62 series, which dimensionally comply with ISO 15: 1998 as regards diameter. However, the unit is slightly wider due to the integral sensor.

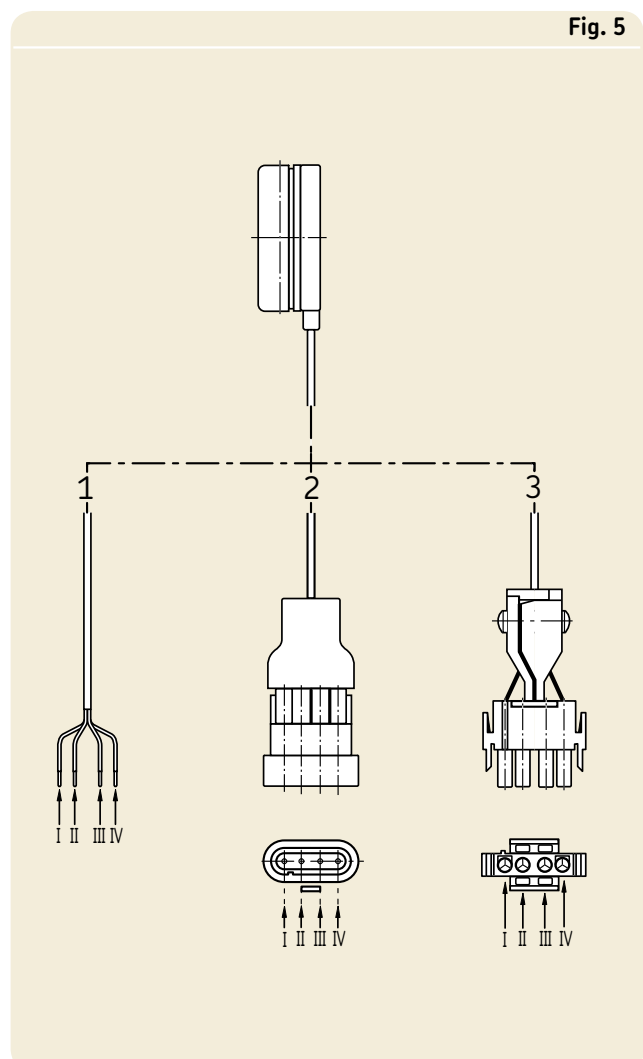
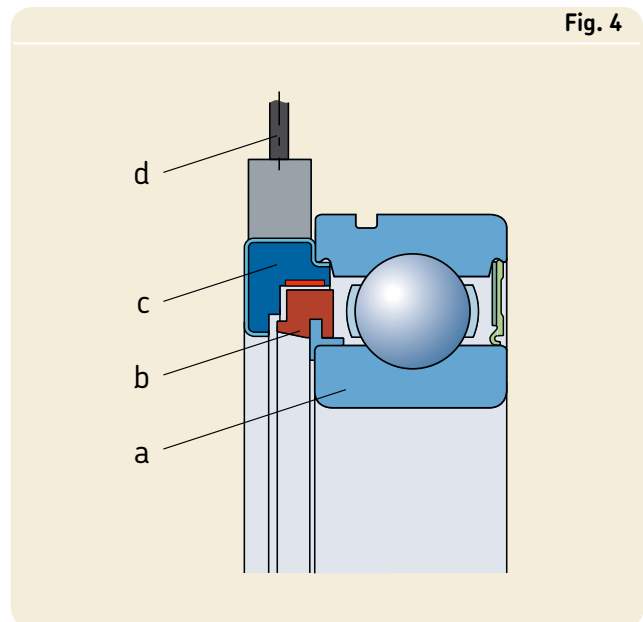

Bearing tolerances

The bearings used for SKF Sensor-Bearing Units are manufactured to P5 tolerances ($d \leq 25$ mm) or P6 tolerances ($d \geq 30$ mm) as standard, which conform to ISO 492:2002 and are listed in the **tables 7 and 8** on **pages 129 and 130**.

Bearing internal clearance

SKF Sensor-Bearing Units have C3 radial internal clearance as specified for deep groove ball bearings in ISO 5753:1991. The values are listed in the product table and are valid for unmounted units under zero measuring load.

Permissible speeds

SKF Sensor-Bearing units are designed to suit the limiting speed of the appropriate sealed bearing. If Sensor-Bearing Units are to be operated at higher speeds than indicated in the product table, please contact the SKF application engineering service.

Temperature range

SKF Sensor-Bearing Units can be used in the temperature range between -40 and $+120$ °C, as extensive long-term testing has proved. For temperatures constantly exceeding $+120$ °C and up to $+150$ °C, please contact the SKF application engineering service.

Electrical interface data

Active sensor operation requires a regulated supply voltage of 5 to 24 V. Signal output is effected via an open collector (\rightarrow **fig. 6**). Resistors inserted between the conductor connected to the voltage supply and the conductors for the output signals limit the output current to 20 mA (\rightarrow **table 1, page 962**). The signal output features are shown in **table 2, page 962**.

Electromagnetic compatibility

SKF Sensor-Bearing Units can be used in systems functioning under most arduous electromagnetic environment such as described in the European Standard EN 50082-2.

Fig. 6

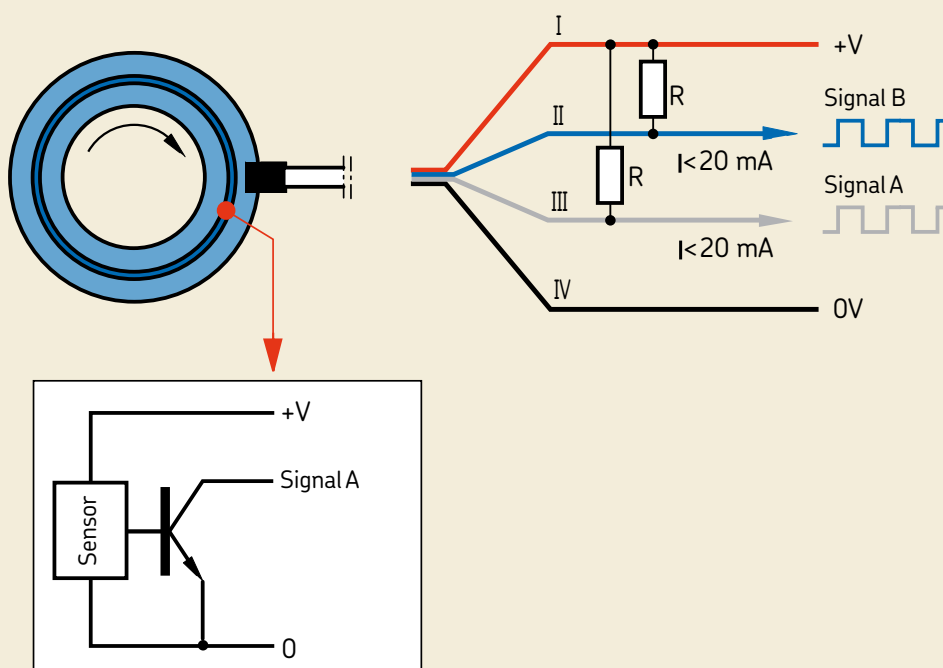

Table 1

Electrical parameters		
Voltage	Recommended resistor	
	R	P
V	Ω	W
5	270	0,25
9	470	0,25
12	680	0,25
24	1 500	0,5

Table 2

Signal output feature	
Feature	Technical data
Signal type	Digital square
Number of signals	2
Phase shift	90 degrees
Duty cycle	50 % of a period

Selection of Sensor-Bearing size

As far as the bearing function is concerned, the selection of the required size of the SKF Sensor-Bearing Unit is made by using the same factors and normal methods as for standard deep groove ball bearings (→ section “Selection of bearing size”, starting on **page 49**).

Application of Sensor-Bearing Units

Two bearings are normally required to support a shaft – a locating and a non-locating bearing. Since the SKF Sensor-Bearing Unit is mainly used as a locating bearing, the opposite shaft end may be supported by a non-locating bearing. If heavy axial loads act on the SKF Sensor-Bearing Unit in both directions, it should be mounted in such a way that the heavier axial load acts on the bearing outer ring side face opposite the sensor unit.

Radial location

In accordance with the general recommendations, the inner ring has a tight fit on the shaft and the outer ring a loose fit in the housing bore. The sensor unit connection cable emerging radially from the bearing determines the position of the outer ring relative to the housing. A sufficiently dimensioned cable duct must be provided in the housing or housing cover (→ **fig. 7**). It is recommended that the cable protruding from the sensor body be protected against excessive rotation by a radial notch in the housing, having a circumferential width of 9 to 15 mm.

Axial location

The inner ring with tight fit is normally located in the axial direction on both sides, e.g. by a shaft shoulder, a distance sleeve or a snap ring. The axial location of the outer ring depends on the bearing size.

For bearings up to and including 25 mm bore diameter the outer ring is located axially on the side opposite to the sensor unit by a shoulder in the housing bore:

- If the bearing is only subjected to light loads or not loaded at all in the opposite direction, a snap ring engaging a groove in the housing bore is sufficient for axial location on the sensor side (→ **fig. 7**).
- In case of heavier axial loads SKF recommends to locate the bearing with an end cover bolted to the housing via a snap ring in the groove of the outer ring.

Larger bearings should abut a housing shoulder with the side face opposite the sensor unit. At the outer ring side face with the sensor the bearing can be axially located either with

- a thin-walled slotted distance sleeve, which abuts the bearing on one side and a snap ring at the other (→ **fig. 8**) or
- an end cover bolted to the housing.

The abutment dimensions can be found in the product table. For detailed information please refer to the product brochure “SKF Sensor-Bearing Units – concentrate intelligence in your motion control” or contact the SKF application engineering service.

Mounting

During mounting SKF Sensor-Bearing Units must be handled with great care in order to avoid damage to the sensor unit and the connection cable. On request SKF can provide customized assistance in optimizing the process of mounting and connection; please contact the SKF application engineering service.

Lubrication and maintenance

SKF Sensor-Bearing Units are supplied as sealed ready-to-mount and ready-to-operate bearing units. They are filled with a polyurea grease for the entire bearing life and suitable for the temperature range of the sensor unit – between -40 and $+120$ °C. The grease fill is adapted to the bearing size. Thus SKF Sensor-Bearing Units are maintenance-free.

Fig. 7

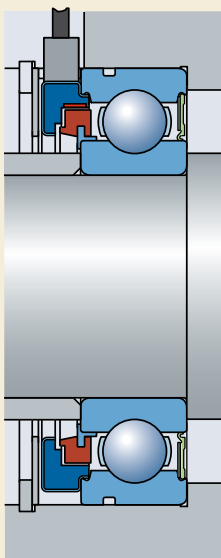
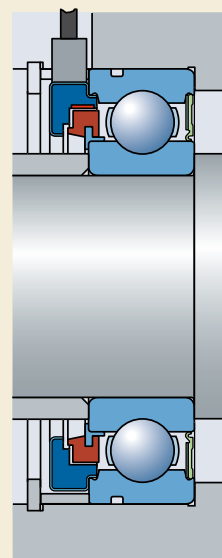
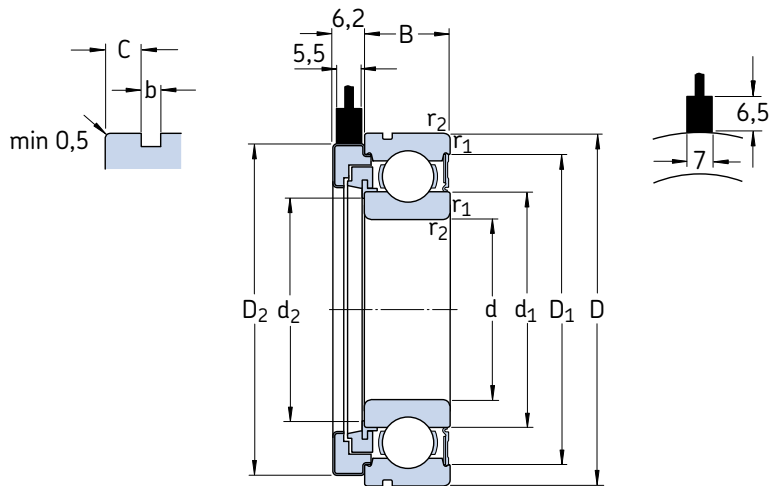

Fig. 8



Sensor-Bearing Units d 15 – 45 mm



Bearing Principal dimensions			Basic load ratings		Fatigue load limit P_u	Limiting speed	Sensor unit			Mass	Designation Unit with 500 mm long cable but without connector Version 1
d	D	B	dynamic C	static C_0			No. of pulses	Period accuracy	Phase shift		
mm			kN	kN	kN	r/min	–	%	degrees	kg	–
15	35	11	8,06	3,75	0,16	13 000	32	± 3	90 ± 30	0,060	BMB-6202/032S2/EA002A
20	47	14	13,5	6,55	0,28	10 000	48	± 3	90 ± 30	0,15	BMB-6204/048S2/EA002A
25	52	15	14,8	7,8	0,34	8 500	48	± 3	90 ± 30	0,18	BMB-6205/048S2/EA002A
30	62	16	20,3	11,2	0,48	7 500	64	± 4	90 ± 45	0,22	BMB-6206/064S2/EA002A
40	80	18	32,5	19	0,8	5 600	80	± 5	90 ± 45	0,40	BMB-6208/080S2/EB002A
45	85	19	35,1	21,6	0,92	5 000	80	± 5	90 ± 45	0,44	BMB-6209/080S2/EB002A

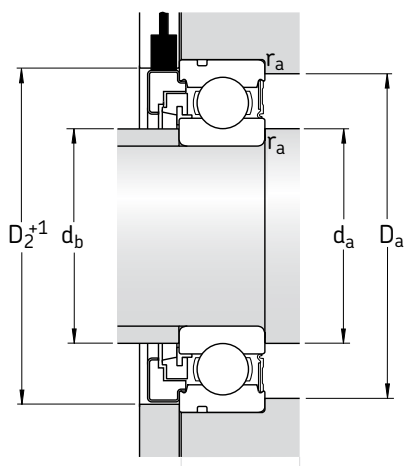

Bore diameter of end cover
 $\geq D_2 + 1 \text{ mm}$

Dimensions								Abutment and fillet dimensions					Radial internal clearance	
d	d ₁	d ₂	D ₁	D ₂	b	C	r _{1,2} min	d _a min	d _b min	d _b max	D _a max	r _a max	min	max
mm								mm					μm	
15	21,5	19,5	30,4	34,4	1,35	2,06	0,6	19	19	19,4	31	0,6	11	25
20	28,5	26,4	40,6	46,4	1,35	2,06	1	25	25	26,3	42	1	13	28
25	34	31,8	46,3	51,4	1,35	2,46	1	30	30	31,5	47	1	13	28
30	40,3	37,8	54,1	58	1,9	3,28	1	35	35	37,5	57	1	13	28
40	52,6	48	69,8	75	1,9	3,28	1,1	46,5	46,5	47,5	73,5	1	15	33
45	57,6	53	75,2	78,8	1,9	3,28	1,1	51,5	51,5	52,5	78,5	1	18	36



SKF

8X-AHE-5507-ED2

FRANCE

M5EE

Steer-By-Wire Modules

SKF Steer-By-Wire Modules are plug-and-play mechatronic components that combine intelligent sensing technology with operational functionality. The module provides an electronic signal that gives information on:

1. the speed and acceleration of steering.
2. the direction of steering.
3. the relative position of the steering wheel.

The plug and play module includes

- an SKF Explorer deep groove ball bearing
- an active sensor
- a steering shaft

which are compactly integrated into a strong steel housing. The exterior surfaces are galvanically coated for protection against corrosion for severe environments. The modules perform well in the temperature range from -40 to $+70$ °C. They are sealed for life and maintenance-free, thus relubrication and steering torque adjustments are never needed.

Active sensor design

The SKF Steer-By-Wire Module incorporates a compact, robust active sensor, which provides the incremental encoder function. Its main components are the magnetic impulse ring and four sensor cells embedded in a body with connecting cables.

The composite magnetized impulse ring, divided into a certain number of north and south poles, is linked to the rotating inner ring of the bearing. The sensor body is attached to the bearing outer ring and equipped with four Hall cells and the connecting cable. An analogue sinusoidal signal generated by the Hall cells is amplified and converted into a square-wave

signal by a Schmitt trigger. The leading signal determines the direction of rotation.

The digital output signals transmitted to the electronic processing control unit, equal to the number of pole pairs on the impulse ring, provide information about

- the shaft's angular position
- direction of rotation
- speed or acceleration of the rotating shaft.

The Steer-By-Wire module electronic output is redundant, containing an identical set of sensors that operate independently. If one set of sensors fails, the other set continues working.

The active sensor requires external voltage supply. The signal output is fed via an open collector circuit.

Designed for demanding applications

SKF Steer-By-Wire Modules are designed to reduce OEM costs while providing more flexibility in cabin design, enhancing operator comfort and ultimately productivity.

SKF Steer-By-Wire Modules can provide the manufacturers of off-road vehicles, including forklift trucks, agricultural, mining, construction and forestry equipment, watercraft or electric carts with more cost effective solutions.

For detailed information about the SKF Steer-By-Wire Modules please contact the SKF application engineering service.



Mast Height Control units

SKF Mast Height Control units (MHC) are plug and play mechatronic components that combine intelligent sensing technology with operational functionality. They are used e.g. in fork lift trucks for control of the height position of the fork unit. The MHC unit provides an electronic signal that gives information on:

1. the relative position of the mast.
2. the direction the mast is moving.
3. the speed and acceleration of the mast.

The MHC unit includes an SKF Explorer class deep groove ball bearing with active sensors integrated in either a pulley or cam roller arrangement. These units interface directly with the vehicle controller to provide useful information to the operator.

SKF MHC units are currently available in two designs:

- A spring-loaded cam arrangement, using spring force to press the sensorized bearing against the moving part of the mast. The mechanical interface of the cam roller unit, which can be customized to meet the OEM requirements, is directly driven by the moving counter surface.
- A pulley arrangement, driven either by a wire or belt that has been incorporated into the design of the mast height positioning system.

Active sensor design

The SKF cam control unit incorporates a compact, robust active sensor, which provides the incremental encoder function. Its main components are the magnetic impulse ring and sensor cells embedded in a body with connecting cables.

The digital output signal is equal to the number of pole pairs on the impulse ring. This is transmitted to the electronic processing control unit, and provides information about the length over which the unit has moved, speed and acceleration of the counter surface, for example that of a fork lift mast. This enables accurate mast height control, which is particularly important to those operations that demand speed and accuracy from the operator or the need of preprogrammed operating cycles. The MHC unit output signals may also be used for simple digital read-out systems or to trigger other safety systems.

Designed for demanding applications

The concept of the SKF Mast Height Control units primarily aims at increased operator efficiency. MHC also has applications well beyond fork lift trucks. They can be adapted to agricultural, forestry, mining and construction equipment and a variety of other applications.

Additional designs of MHC units can be developed based on specific requirements. For detailed information about the SKF cam control units please contact the SKF application engineering service.



Other sensorized units

The SKF range of sensorized units is not limited to deep groove ball bearings and the units described on the previous pages. In the course of the development, the sensor concept was implemented many years ago with other bearing types as well.

Several SKF publications are available with detailed information on these sensorized bearing units and can be supplied by request.

Sensorized units for road vehicles

Pioneering developments in engineering often start in vehicle construction. For reasons of both weight reduction and safety, more and more vehicles are being equipped with speed sensing devices. The optimum wheel speed sensor solution is however unique for each individual application. Depending on requirements the sensor can be either non-integrated or integrated to improve reliability, save weight and ease assembly. The sensor may also be either of

- the passive type, which is capable of providing signals down to a speed of a few km/h sufficient for ABS or of
- the active type, which can provide signals down to zero speed, necessary for systems such as traction control or navigation.

Whatever the solution, SKF can help to take advantage of these opportunities by offering a wide range of existing solutions for both car as well as truck hub units.

Sensorized bearing units for rail vehicles

Operating conditions in rail vehicles are especially arduous. The units must not only tolerate vibration, impact loads, heavy loads and

extreme temperatures, but must provide high operational reliability over great distances and with long maintenance intervals. The same is true for the integral sensors, which control the braking system, provide optimum frictional engagement of the driving wheels on starting-up and detect the direction of rotation.

The SKF sensorized tapered bearing units (TBU) for rail vehicles are compact, ready-to-mount and easy-to-install solutions, having a taper roller bearing as the basic bearing.

Apart from these bearing units with speed sensors, bearing units with temperature sensors are also available from SKF. They enable immediate and permanent monitoring of bearing temperature, detecting hot-running axle-boxes and bearing damage in operation.

Sensorized bearing units for traction motors

Sensorized bearing units with integral speed and temperature sensors for railway drive systems, the traction motor bearing units (TMBU), are another speciality from SKF. Two standard basic versions are available

- for the locating position, a deep groove ball bearing unit with a flanged outer ring for attachment to the motor shield
- for the non-locating position, a cylindrical roller bearing unit.

The SKF TMBU concept combines in one unit all the functions important for the bearing arrangement, also including the insulation, if required.



Bearing accessories

Adapter sleeves..... 975

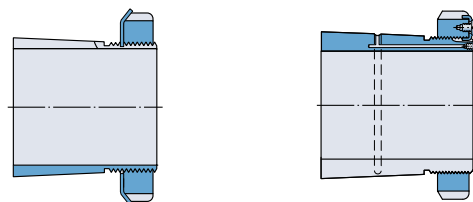

Withdrawal sleeves 995



Lock nuts 1007

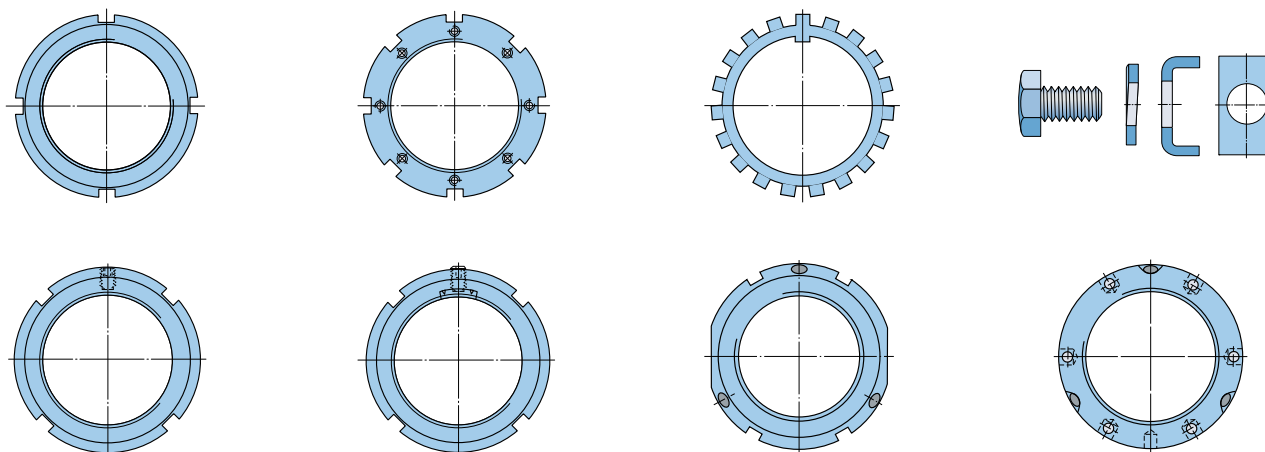



Adapter sleeves

Designs	976
Basic design.....	976
Designs for oil injection	977
Designs for CARB toroidal roller bearings	978
Design for sealed bearings	978
Product data – general.....	979
Dimensions.....	979
Tolerances.....	979
Thread	979
Shaft tolerances.....	979
Product tables	980
Adapter sleeves for metric shafts	980
Adapter sleeves for inch shafts	988

Designs

Adapter sleeves are the most commonly used components for locating bearings with a tapered bore onto a cylindrical seating as they can be used on smooth or stepped shafts (→ **fig. 1**). They are easy to mount and require no additional location on the shaft.

When adapter sleeves are used on smooth shafts, the bearing can be located at any position on the shaft. When used on stepped shafts, together with a stepped ring, bearings can be accurately positioned axially and bearing dismounting is also facilitated.

Basic design

SKF adapter sleeves are supplied complete with lock nut and locking device (→ **fig. 2**). Smaller sizes use a lock nut with a locking washer (**a**), larger sizes use a nut with locking clip (**b**). The sleeves are slotted and have an external taper of 1:12. Up to size 40, the sleeves are phosphated. Larger sizes are untreated and protected by a solventless rust inhibitor.

SKF supplies adapter sleeves for metric and inch shafts. This catalogue contains metric adapter sleeves that fit both metric and inch shafting. For other inch adapter sleeves, please refer to the SKF catalogue “Bearing accessories” or to the “SKF Interactive Engineering Catalogue” on CD-ROM or online at www.skf.com.

Fig. 1

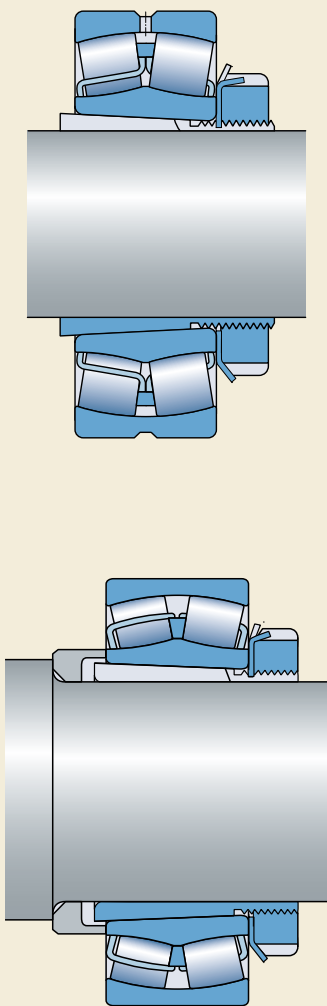
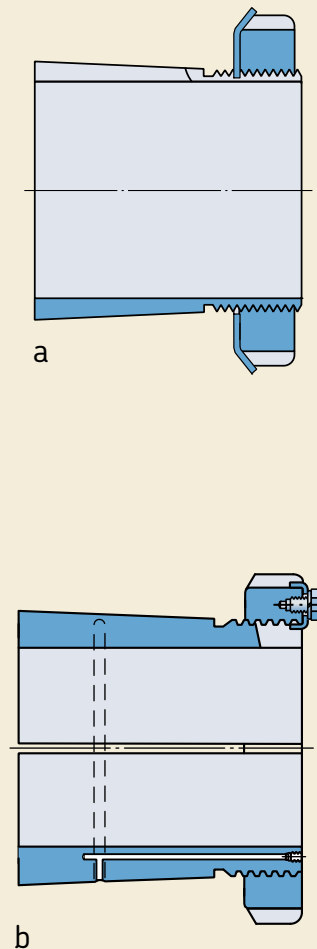

Fig. 2



Designs for oil injection

To enable the oil injection method to be used to ease mounting and dismounting, SKF adapter sleeves having a bore diameter of 140 mm up to 200 mm can be supplied to special order already prepared for oil injection (→ **fig. 3**). This feature is standard for sleeves having a bore diameter of 200 mm and above. These adapter sleeves (**a**) have an oil duct at the threaded side and an oil distributor groove on the outside surface. If oil is injected through this duct and groove, an oil film is formed between the mating surfaces of the bearing and sleeve and the force required to mount the bearing is reduced considerably. Details of the thread for attaching the oil supply lead to the duct as well as of appropriate hydraulic nuts can be found in the product tables.

In addition to these standard sleeves which are designated OH .. H and shown in the product tables, SKF produces sleeves to three other designs which differ in the number and arrangement of the oil ducts and distributor grooves, as described below.

OH design (b)

The oil supply duct is at the side opposite to the threaded section and there is a distributor groove in the outside surface.

OH .. B design (c)

The oil supply duct (or ducts) is at the side opposite to the threaded section and there are distributor grooves in the bore as well as the outside surface. Sleeves up to and including size 40 have one supply duct, larger sleeves have two.

OH .. HB design (d)

These sleeves have an oil supply duct (or ducts) at the threaded side of the sleeve and distributor grooves in the bore as well as the outside surface. Sleeves up to and including size 40 have one supply duct, larger sleeves have two.

The equipment required for the oil injection method is also supplied by SKF. The use of hydraulic nuts can considerably facilitate mounting and dismounting (→ section "Maintenance and lubrication products", starting on **page 1069**).

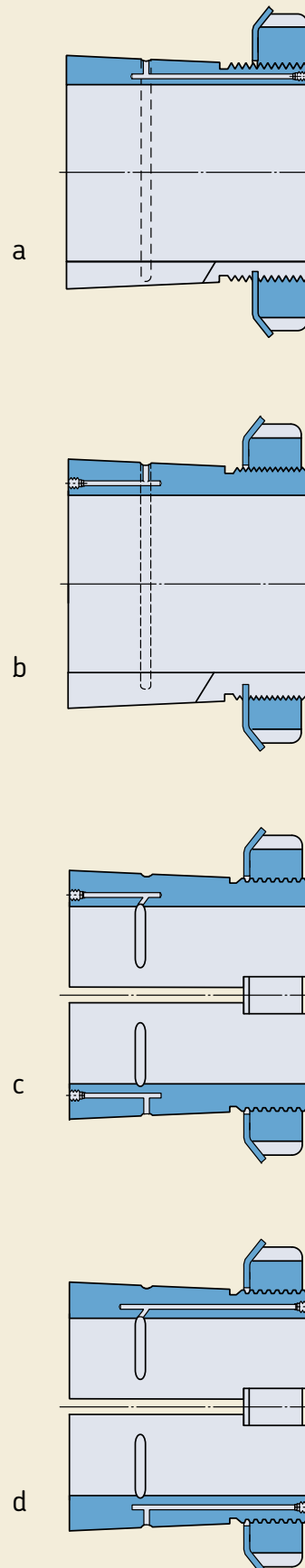

Adapter sleeves

Designs for CARB toroidal roller bearings

Where appropriate, modified adapter sleeves of the E, L and TL designs (→ **fig. 4**) are available for CARB bearings, to prevent the locking device from chafing the cage:

- With E-design sleeves, the standard KM lock nut and MB locking washer are replaced by a KMFE lock nut (**a**), and the standard HM 30 lock nut is replaced by an HME lock nut with a recessed outside diameter (**b**).
- L-design sleeves (**c**) differ from the standard design in that the standard KM lock nut and MB locking washer have been replaced by a KML lock nut and MBL locking washer; these have a lower sectional height.
- With the TL-design sleeve (**d**), the standard HM .. T lock nut and MB locking washer have been replaced by the corresponding HM 30 lock nut and MS 30 locking clip; these have a lower sectional height.

Design for sealed bearings

When using sealed bearings on adapter sleeves, make sure that the lock nut or locking washer will not damage the seal. Sleeves in the E, C, L or TL designs are suitable for sealed bearings. The locking washer used with the H 3 .. C series adapter sleeve has a protrusion on the side directed towards the bearing (→ **fig. 5**).

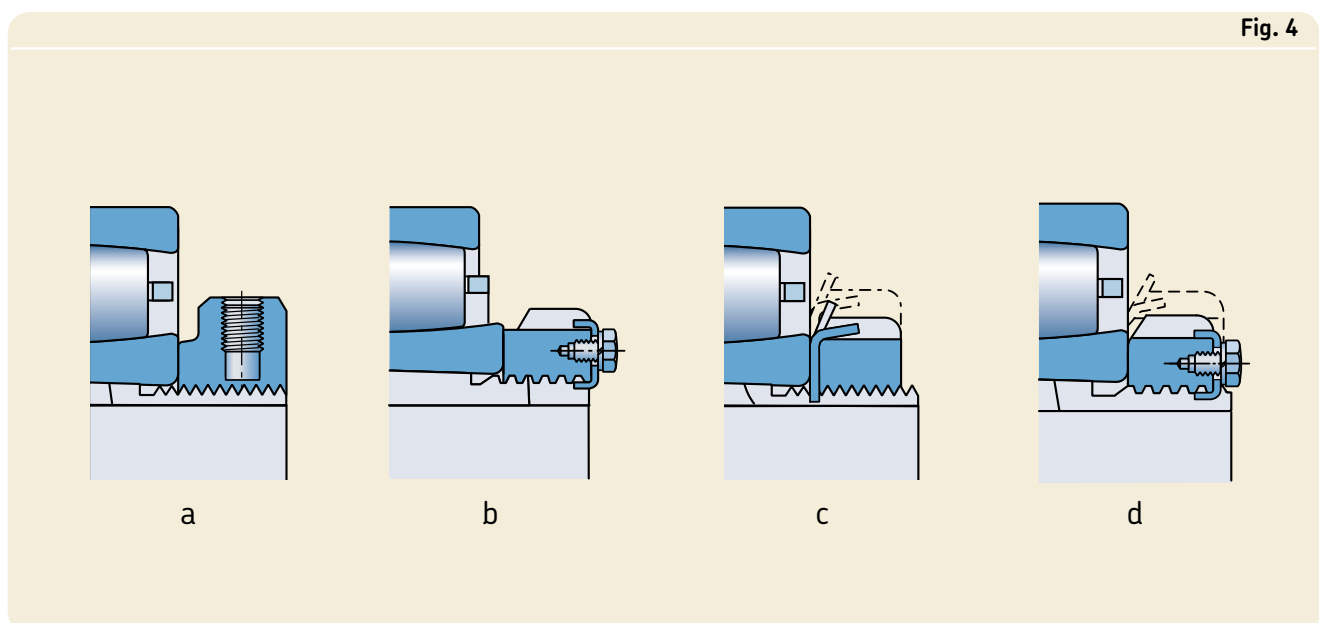

Product data – general

Dimensions

The dimensions of SKF adapter sleeves are in accordance with ISO 2982-1:1995; except the bore diameter of sleeves for inch shafts.

Tolerances

The bore diameter of SKF adapter sleeves is to tolerance JS9, the width to h15.

Thread

SKF adapter sleeves up to size 40 have metric threads with 6g tolerances, according to ISO 965-3:1998. Larger adapter sleeves have metric trapezoidal threads with 7e tolerances, according to ISO 2903:1993.

Shaft tolerances

As the name implies, adapter sleeves adapt themselves to the shaft diameter, so that wider diameter tolerances can be permitted than for the seating of a bearing with a cylindrical bore. However, the form tolerances must be kept within narrow limits as the accuracy of form directly affects the running accuracy of the bearing. Generally, shafts should be to an h9 tolerance but the cylindricity should be to IT5/2 according to ISO 1101:2004.

Fig. 5

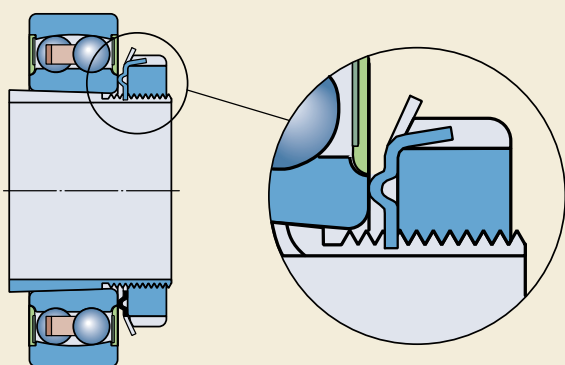

Adapter sleeves for metric shafts

d_1 17 – 75 mm

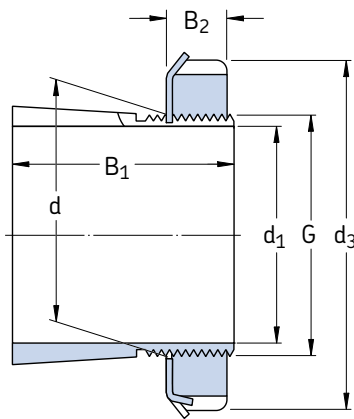

H

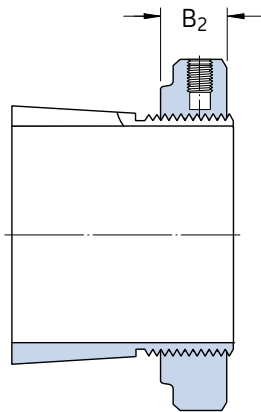

H..E

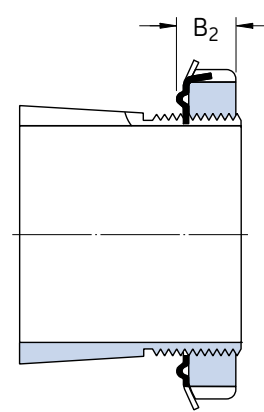

H..C

Dimensions						Mass	Designations	Appertaining lock nut	locking device	Appropriate hydraulic nut
d_1	d	d_3	B_1	B_2	G					
mm						kg	–			
17	20	32	24	7	M 20x1	0,036	H 204	KM 4	MB 4	–
	20	32	28	7	M 20x1	0,040	H 304	KM 4	MB 4	–
	20	32	28	9,5	M 20x1	0,047	H 304 E	KMFE 4	–	–
20	25	38	26	8	M 25x1,5	0,064	H 205	KM 5	MB 5	–
	25	38	29	8	M 25x1,5	0,071	H 305	KM 5	MB 5	–
	25	38	29	9	M 25x1,5	0,071	H 305 C	KM 5	MB 5 C	–
	25	38	29	10,5	M 25x1,5	0,076	H 305 E	KMFE 5	–	–
	25	38	35	8	M 25x1,5	0,085	H 2305	KM 5	MB 5	–
25	30	45	27	8	M 30x1,5	0,086	H 206	KM 6	MB 6	–
	30	45	31	8	M 30x1,5	0,095	H 306	KM 6	MB 6	–
	30	45	31	9	M 30x1,5	0,095	H 306 C	KM 6	MB 6 C	–
	30	45	31	10,5	M 30x1,5	0,11	H 306 E	KMFE 6	–	–
	30	45	38	8	M 30x1,5	0,11	H 2306	KM 6	MB 6	–
30	35	52	29	9	M 35x1,5	0,12	H 207	KM 7	MB 7	–
	35	52	35	9	M 35x1,5	0,14	H 307	KM 7	MB 7	–
	35	52	35	10	M 35x1,5	0,14	H 307 C	KM 7	MB 7 C	–
	35	52	35	11,5	M 35x1,5	0,15	H 307 E	KMFE 7	–	–
	35	52	43	9	M 35x1,5	0,16	H 2307	KM 7	MB 7	–
35	40	58	31	10	M 40x1,5	0,16	H 208	KM 8	MB 8	–
	40	58	36	10	M 40x1,5	0,17	H 308	KM 8	MB 8	–
	40	58	36	11	M 40x1,5	0,17	H 308 C	KM 8	MB 8 C	–
	40	58	36	13	M 40x1,5	0,19	H 308 E	KMFE 8	–	–
	40	58	46	10	M 40x1,5	0,22	H 2308	KM 8	MB 8	–
40	45	65	33	11	M 45x1,5	0,21	H 209	KM 9	MB 9	–
	45	65	39	11	M 45x1,5	0,23	H 309	KM 9	MB 9	–
	45	65	39	12	M 45x1,5	0,23	H 309 C	KM 9	MB 9 C	–
	45	65	39	13	M 45x1,5	0,24	H 309 E	KMFE 9	–	–
	45	65	50	11	M 45x1,5	0,27	H 2309	KM 9	MB 9	–
45	50	70	35	12	M 50x1,5	0,24	H 210	KM 10	MB 10	HMV 10 E
	50	70	42	12	M 50x1,5	0,27	H 310	KM 10	MB 10	HMV 10 E
	50	70	42	13	M 50x1,5	0,27	H 310 C	KM 10	MB 10 C	HMV 10 E
	50	70	42	14	M 50x1,5	0,30	H 310 E	KMFE 10	–	HMV 10 E
	50	70	55	12	M 50x1,5	0,34	H 2310	KM 10	MB 10	HMV 10 E

Dimensions						Mass	Designations	Appertaining lock nut	locking device	Appropriate hydraulic nut
d ₁	d	d ₃	B ₁	B ₂	G		Adapter sleeve with nut and locking device			
mm						kg	–			
50	55	75	37	12,5	M 55x2	0,28	H 211	KM 11	MB 11	HMV 11 E
	55	75	45	12,5	M 55x2	0,32	H 311	KM 11	MB 11	HMV 11 E
	55	75	45	13	M 55x2	0,32	H 311 C	KM 11	MB 11 C	HMV 11 E
	55	75	45	14	M 55x2	0,34	H 311 E	KMFE 11	–	HMV 11 E
	55	75	59	12,5	M 55x2	0,39	H 2311	KM 11	MB 11	HMV 11 E
55	60	80	38	12,5	M 60x2	0,31	H 212	KM 12	MB 12	HMV 12 E
	60	80	47	12,5	M 60x2	0,36	H 312	KM 12	MB 12	HMV 12 E
	60	80	47	14	M 60x2	0,40	H 312 E	KMFE 12	–	HMV 12 E
	60	80	62	12,5	M 60x2	0,45	H 2312	KM 12	MB 12	HMV 12 E
60	65	85	40	13,5	M 65x2	0,36	H 213	KM 13	MB 13	HMV 13 E
	65	85	50	13,5	M 65x2	0,42	H 313	KM 13	MB 13	HMV 13 E
	65	85	50	14,5	M 65x2	0,42	H 313 C	KM 13	MB 13 C	HMV 13 E
	65	85	50	15	M 65x2	0,43	H 313 E	KMFE 13	–	HMV 13 E
	65	85	65	13,5	M 65x2	0,52	H 2313	KM 13	MB 13	HMV 13 E
	70	92	52	13,5	M 70x2	0,67	H 314	KM 14	MB 14	HMV 14 E
65	70	92	52	15	M 70x2	0,67	H 314 E	KMFE 14	–	HMV 14 E
	70	92	68	13,5	M 70x2	0,88	H 2314	KM 14	MB 14	HMV 14 E
	75	98	43	14,5	M 75x2	0,66	H 215	KM 15	MB 15	HMV 15 E
70	75	98	55	14,5	M 75x2	0,78	H 315	KM 15	MB 15	HMV 15 E
	75	98	55	16	M 75x2	0,80	H 315 E	KMFE 15	–	HMV 15 E
	75	98	73	14,5	M 75x2	1,10	H 2315	KM 15	MB 15	HMV 15 E
	80	105	46	17	M 80x2	0,81	H 216	KM 16	MB 16	HMV 16 E
75	80	105	59	17	M 80x2	0,95	H 316	KM 16	MB 16	HMV 16 E
	80	105	59	18	M 80x2	1,01	H 316 E	KMFE 16	–	HMV 16 E
	80	105	78	17	M 80x2	1,20	H 2316	KM 16	MB 16	HMV 16 E
	85	110	50	18	M 85x2	0,94	H 217	KM 17	MB 17	HMV 17 E
70	85	110	63	18	M 85x2	1,10	H 317	KM 17	MB 17	HMV 17 E
	85	110	63	19	M 85x2	1,17	H 317 E	KMFE 17	–	HMV 17 E
	85	110	82	18	M 85x2	1,35	H 2317	KM 17	MB 17	HMV 17 E

Adapter sleeves for metric shafts

d_1 80 – 180 mm

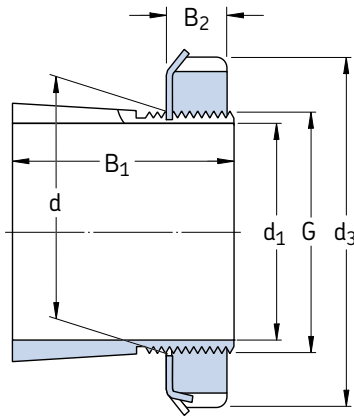

H, H..L

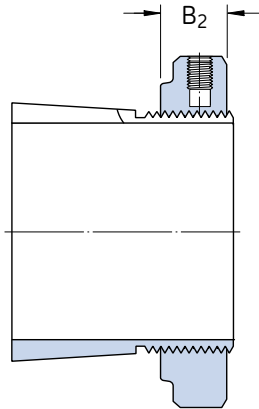

H..E

Dimensions						Mass	Designations Adapter sleeve with nut and locking device	Appertaining lock nut	locking device	Appropriate hydraulic nut
d_1	d	d_3	B_1	B_2	G					
mm						kg	–			
80	90	120	52	18	M 90x2	1,10	H 218	KM 18	MB 18	HMV 18 E
	90	120	65	18	M 90x2	1,30	H 318	KM 18	MB 18	HMV 18 E
	90	120	65	19	M 90x2	1,43	H 318 E	KMFE 18	–	HMV 18 E
	90	120	86	18	M 90x2	1,60	H 2318	KM 18	MB 18	HMV 18 E
85	95	125	55	19	M 95x2	1,25	H 219	KM 19	MB 19	HMV 19 E
	95	125	68	19	M 95x2	1,40	H 319	KM 19	MB 19	HMV 19 E
	95	125	68	20	M 95x2	1,41	H 319 E	KMFE 19	–	HMV 19 E
	95	125	90	19	M 95x2	1,80	H 2319	KM 19	MB 19	HMV 19 E
90	100	130	58	20	M 100x2	1,40	H 220	KM 20	MB 20	HMV 20 E
	100	130	71	20	M 100x2	1,60	H 320	KM 20	MB 20	HMV 20 E
	100	130	71	21	M 100x2	1,72	H 320 E	KMFE 20	–	HMV 20 E
	100	130	76	20	M 100x2	1,80	H 3120	KM 20	MB 20	HMV 20 E
	100	130	97	20	M 100x2	2,00	H 2320	KM 20	MB 20	HMV 20 E
100	110	145	63	21	M 110x2	1,80	H 222	KM 22	MB 22	HMV 22 E
	110	145	77	21	M 110x2	2,04	H 322	KM 22	MB 22	HMV 22 E
	110	145	77	21,5	M 110x2	2,11	H 322 E	KMFE 22	–	HMV 22 E
	110	145	81	21	M 110x2	2,10	H 3122	KM 22	MB 22	HMV 22 E
	110	145	105	21	M 110x2	2,75	H 2322	KM 22	MB 22	HMV 22 E
110	120	145	72	22	M 120x2	1,80	H 3024	KML 24	MBL 24	HMV 24 E
	120	155	72	26	M 120x2	1,87	H 3024 E	KMFE 24	–	HMV 24 E
	120	155	88	22	M 120x2	2,50	H 3124	KM 24	MB 24	HMV 24 E
	120	145	88	22	M 120x2	2,50	H 3124 L	KML 24	MBL 24	HMV 24 E
	120	155	112	22	M 120x2	3,00	H 2324	KM 24	MB 24	HMV 24 E
	120	145	112	22	M 120x2	3,12	H 2324 L	KML 24	MBL 24	HMV 24 E
115	130	155	80	23	M 130x2	2,80	H 3026	KML 26	MBL 26	HMV 26 E
	130	165	92	23	M 130x2	3,45	H 3126	KM 26	MB 26	HMV 26 E
	130	155	92	23	M 130x2	3,65	H 3126 L	KML 26	MBL 26	HMV 26 E
	130	165	121	23	M 130x2	4,45	H 2326	KM 26	MB 26	HMV 26 E
125	140	165	82	24	M 140x2	3,05	H 3028	KML 28	MBL 28	HMV 28 E
	140	180	97	24	M 140x2	4,10	H 3128	KM 28	MB 28	HMV 28 E
	140	165	97	24	M 140x2	3,62	H 3128 L	KML 28	MBL 28	HMV 28 E
	140	180	131	24	M 140x2	5,40	H 2328	KM 28	MB 28	HMV 28 E

Dimensions						Mass	Designations	Appertaining lock nut	locking device	Appropriate hydraulic nut
d ₁	d	d ₃	B ₁	B ₂	G		Adapter sleeve with nut and locking device			
mm						kg	–			
135	150	180	87	26	M 150×2	3,75	H 3030	KML 30	MBL 30	HMV 30 E
	150	195	111	26	M 150×2	5,25	H 3130	KM 30	MB 30	HMV 30 E
	150	180	111	26	M 150×2	4,70	H 3130 L	KML 30	MBL 30	HMV 30 E
	150	195	139	26	M 150×2	6,40	H 2330	KM 30	MB 30	HMV 30 E
140	160	190	93	27,5	M 160×3	5,10	H 3032	KML 32	MBL 32	HMV 32 E
	160	210	119	27,5	M 160×3	7,25	H 3132	KM 32	MB 32	HMV 32 E
	160	190	119	27,5	M 160×3	6,40	H 3132 L	KML 32	MBL 32	HMV 32 E
	160	210	147	27,5	M 160×3	8,80	H 2332	KM 32	MB 32	HMV 32 E
	160	190	147	27,5	M 160×3	7,95	H 2332 L	KML 32	MBL 32	HMV 32 E
150	170	200	101	28,5	M 170×3	5,80	H 3034	KML 34	MBL 34	HMV 34 E
	170	220	122	28,5	M 170×3	8,10	H 3134	KM 34	MB 34	HMV 34 E
	170	200	122	28,5	M 170×3	7,15	H 3134 L	KML 34	MBL 34	HMV 34 E
	170	220	154	28,5	M 170×3	9,90	H 2334	KM 34	MB 34	HMV 34 E
160	180	210	87	29,5	M 180×3	5,70	H 3936	KML 36	MBL 36	HMV 36 E
	180	210	109	29,5	M 180×3	6,70	H 3036	KML 36	MBL 36	HMV 36 E
	180	230	131	29,5	M 180×3	9,15	H 3136	KM 36	MB 36	HMV 36 E
	180	210	131	29,5	M 180×3	8,15	H 3136 L	KML 36	MBL 36	HMV 36 E
	180	230	161	30	M 180×3	11,0	H 2336	KM 36	MB 36	HMV 36 E
170	190	220	89	30,5	M 190×3	6,20	H 3938	KML 38	MBL 38	HMV 38 E
	190	220	112	30,5	M 190×3	7,25	H 3038	KML 38	MBL 38	HMV 38 E
	190	240	141	30,5	M 190×3	10,5	H 3138	KM 38	MB 38	HMV 38 E
	190	240	169	30,5	M 190×3	12,0	H 2338	KM 38	MB 38	HMV 38 E
180	200	240	98	31,5	M 200×3	7,90	H 3940	KML 40	MBL 40	HMV 40 E
	200	240	120	31,5	M 200×3	8,90	H 3040	KML 40	MBL 40	HMV 40 E
	200	250	150	31,5	M 200×3	12,0	H 3140	KM 40	MB 40	HMV 40 E
	200	250	176	31,5	M 200×3	13,5	H 2340	KM 40	MB 40	HMV 40 E

Adapter sleeves for metric shafts

d_1 200 – 450 mm

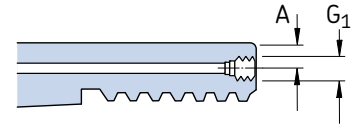
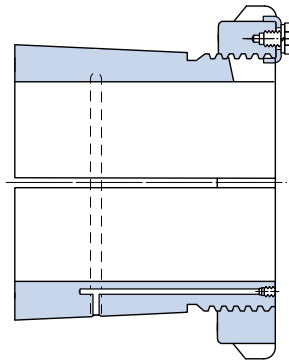
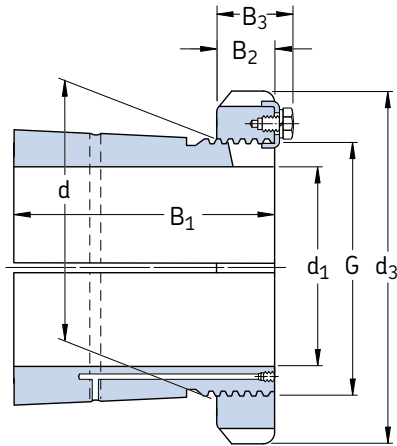

OH .. H, OH .. HTL

OH .. HE

Dimensions										Mass	Designations	Appertaining lock nut	locking device	Appropriate hydraulic nut
d_1	d	d_3	B_1	B_2	B_3	G		G_1	A	Adapter sleeve with nut and locking device				
mm										kg	–			
200	220	260	96	30	41	Tr 220x4	M 6	4,2	7,95	OH 3944 H	HM 3044	MS 3044	HMV 44 E	
	220	260	126	30	41	Tr 220x4	M 6	4,2	9,90	OH 3044 H	HM 3044	MS 3044	HMV 44 E	
	220	280	161	35	–	Tr 220x4	M 6	4,2	15,0	OH 3144 H	HM 44 T	MB 44	HMV 44 E	
	220	260	161	30	41	Tr 220x4	M 6	4,2	14,3	OH 3144 HTL	HM 3044	MS 3044	HMV 44 E	
	220	280	186	35	–	Tr 220x4	M 6	4,2	17,0	OH 2344 H	HM 44 T	MB 44	HMV 44 E	
220	240	290	101	34	46	Tr 240x4	M 6	4,2	11,0	OH 3948 H	HM 3048	MS 3052-48	HMV 48 E	
	240	290	133	34	46	Tr 240x4	M 6	4,2	12,0	OH 3048 H	HM 3048	MS 3052-48	HMV 48 E	
	240	300	172	37	–	Tr 240x4	M 6	4,2	16,5	OH 3148 H	HM 48 T	MB 48	HMV 48 E	
	240	290	172	34	46	Tr 240x4	M 6	4,2	15,1	OH 3148 HTL	HM 3048	MS 3052-48	HMV 48 E	
	240	300	199	37	–	Tr 240x4	M 6	4,2	19,0	OH 2348 H	HM 48 T	MB 48	HMV 48 E	
240	260	310	116	34	46	Tr 260x4	M 6	4,2	11,7	OH 3952 H	HM 3052	MS 3052-48	HMV 52 E	
	260	310	145	34	46	Tr 260x4	M 6	4,2	13,5	OH 3052 H	HM 3052	MS 3052-48	HMV 52 E	
	260	330	190	39	–	Tr 260x4	M 6	4,2	21,0	OH 3152 H	HM 52 T	MB 52	HMV 52 E	
	260	310	190	34	46	Tr 260x4	M 6	4,2	17,7	OH 3152 HTL	HM 3052	MS 3052-48	HMV 52 E	
	260	330	211	39	–	Tr 260x4	M 6	4,2	23,0	OH 2352 H	HM 52 T	MB 52	HMV 52 E	
260	280	330	121	38	50	Tr 280x4	M 6	4,2	15,3	OH 3956 H	HM 3056	MS 3056	HMV 56 E	
	280	330	152	38	50	Tr 280x4	M 6	4,2	16,0	OH 3056 H	HM 3056	MS 3056	HMV 56 E	
	280	350	195	41	–	Tr 280x4	M 6	4,2	23,0	OH 3156 H	HM 56 T	MB 56	HMV 56 E	
	280	330	195	38	50	Tr 280x4	M 6	4,2	19,3	OH 3156 HTL	HM 3056	MS 3056	HMV 56 E	
	280	350	224	41	–	Tr 280x4	M 6	4,2	27,0	OH 2356 H	HM 56 T	MB 56	HMV 56 E	
280	300	360	140	42	54	Tr 300x4	M 6	4,2	20,0	OH 3960 H	HM 3060	MS 3060	HMV 60 E	
	300	360	168	42	54	Tr 300x4	M 6	4,2	20,5	OH 3060 H	HM 3060	MS 3060	HMV 60 E	
	300	380	208	40	53	Tr 300x4	M 6	4,2	29,0	OH 3160 H	HM 3160	MS 3160	HMV 60 E	
	300	380	240	40	53	Tr 300x4	M 6	4,2	32,0	OH 3260 H	HM 3160	MS 3160	HMV 60 E	
300	320	380	140	42	55	Tr 320x5	M 6	4	21,5	OH 3964 H	HM 3064	MS 3068-64	HMV 64 E	
	320	380	171	42	55	Tr 320x5	M 6	4	22,0	OH 3064 H	HM 3064	MS 3068-64	HMV 64 E	
	320	400	226	42	56	Tr 320x5	M 6	4	32,0	OH 3164 H	HM 3164	MS 3164	HMV 64 E	
	320	400	258	42	56	Tr 320x5	M 6	4	35,0	OH 3264 H	HM 3164	MS 3164	HMV 64 E	
320	340	400	144	45	58	Tr 340x5	M 6	4	24,5	OH 3968 H	HM 3068	MS 3068-64	HMV 68 E	
	340	400	187	45	58	Tr 340x5	M 6	4	27,0	OH 3068 H	HM 3068	MS 3068-64	HMV 68 E	
	340	440	254	55	72	Tr 340x5	M 6	4	50,0	OH 3168 H	HM 3168	MS 3172-68	HMV 68 E	
	340	440	288	55	72	Tr 340x5	M 6	4	51,5	OH 3268 H	HM 3168	MS 3172-68	HMV 68 E	

For OH .. HE sleeves not listed in the table, please contact SKF

Dimensions									Mass	Designations			
d ₁	d	d ₃	B ₁	B ₂	B ₃	G	G ₁	A		Adapter sleeve with nut and locking device	Appertaining lock nut	locking device	Appropriate hydraulic nut
mm									kg	-			
340	360	420	144	45	58	Tr 360x5	M 6	4	25,2	OH 3972 H	HM 3072	MS 3072	HMV 72 E
	360	420	144	45	58	Tr 360x5	M 6	4	25,2	OH 3972 HE	HME 3072	MS 3072	HMV 72 E
	360	420	188	45	58	Tr 360x5	M 6	4	29,0	OH 3072 H	HM 3072	MS 3072	HMV 72 E
	360	460	259	58	75	Tr 360x5	M 6	4	56,0	OH 3172 H	HM 3172	MS 3172-68	HMV 72 E
	360	460	299	58	75	Tr 360x5	M 6	4	60,5	OH 3272 H	HM 3172	MS 3172-68	HMV 72 E
360	380	450	164	48	62	Tr 380x5	M 6	4	31,5	OH 3976 H	HM 3076	MS 3080-76	HMV 76 E
	380	450	193	48	62	Tr 380x5	M 6	4	35,5	OH 3076 H	HM 3076	MS 3080-76	HMV 76 E
	380	490	264	60	77	Tr 380x5	M 6	4	61,5	OH 3176 H	HM 3176	MS 3176	HMV 76 E
	380	490	310	60	77	Tr 380x5	M 6	4	69,5	OH 3276 H	HM 3176	MS 3176	HMV 76 E
380	400	470	168	52	66	Tr 400x5	M 6	4	35,0	OH 3980 H	HM 3080	MS 3080-76	HMV 80 E
	400	470	210	52	66	Tr 400x5	M 6	4	40,0	OH 3080 H	HM 3080	MS 3080-76	HMV 80 E
	400	520	272	62	82	Tr 400x5	M 6	4	73,0	OH 3180 H	HM 3180	MS 3184-80	HMV 80 E
	400	520	328	62	82	Tr 400x5	M 6	4	87,0	OH 3280 H	HM 3180	MS 3184-80	HMV 80 E
400	420	490	168	52	66	Tr 420x5	M 6	4	36,0	OH 3984 H	HM 3084	MS 3084	HMV 84 E
	420	490	168	52	66	Tr 420x5	M 6	4	36,0	OH 3984 HE	HME 3084	MS 3084	HMV 84 E
	420	490	212	52	66	Tr 420x5	M 6	4	47,0	OH 3084 H	HM 3084	MS 3084	HMV 84 E
	420	540	304	70	90	Tr 420x5	M 6	4	80,0	OH 3184 H	HM 3184	MS 3184-80	HMV 84 E
	420	540	352	70	90	Tr 420x5	M 6	4	96,0	OH 3284 H	HM 3184	MS 3184-80	HMV 84 E
410	440	520	189	60	77	Tr 440x5	M 8	6,5	58,0	OH 3988 H	HM 3088	MS 3092-88	HMV 88 E
	440	520	228	60	77	Tr 440x5	M 8	6,5	65,0	OH 3088 H	HM 3088	MS 3092-88	HMV 88 E
	440	560	307	70	90	Tr 440x5	M 8	6,5	95,0	OH 3188 H	HM 3188	MS 3192-88	HMV 88 E
	440	560	361	70	90	Tr 440x5	M 8	6,5	117	OH 3288 H	HM 3188	MS 3192-88	HMV 88 E
430	460	540	189	60	77	Tr 460x5	M 8	6,5	60,0	OH 3992 H	HM 3092	MS 3092-88	HMV 92 E
	460	540	234	60	77	Tr 460x5	M 8	6,5	71,0	OH 3092 H	HM 3092	MS 3092-88	HMV 92 E
	460	580	326	75	95	Tr 460x5	M 8	6,5	119	OH 3192 H	HM 3192	MS 3192-88	HMV 92 E
	460	580	382	75	95	Tr 460x5	M 8	6,5	134	OH 3292 H	HM 3192	MS 3192-88	HMV 92 E
450	480	560	200	60	77	Tr 480x5	M 8	6,5	66,0	OH 3996 H	HM 3096	MS 30/500-96	HMV 96 E
	480	560	200	60	77	Tr 480x5	M 8	6,5	66,0	OH 3996 HE	HME 3096	MS 30/500-96	HMV 96 E
	480	560	237	60	77	Tr 480x5	M 8	6,5	75,0	OH 3096 H	HM 3096	MS 30/500-96	HMV 96 E
	480	620	335	75	95	Tr 480x5	M 8	6,5	135	OH 3196 H	HM 3196	MS 3196	HMV 96 E
	480	620	397	75	95	Tr 480x5	M 8	6,5	153	OH 3296 H	HM 3196	MS 3196	HMV 96 E

For OH .. HE sleeves not listed in the table, please contact SKF

Adapter sleeves for metric shafts

d_1 470 – 1 000 mm

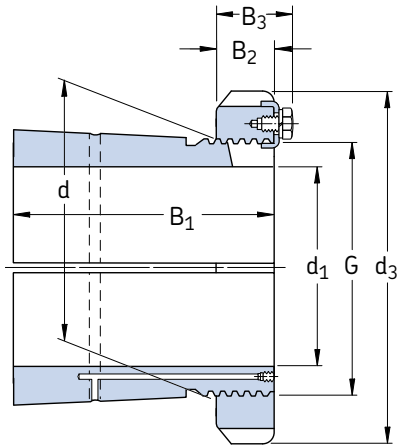

OH .. H

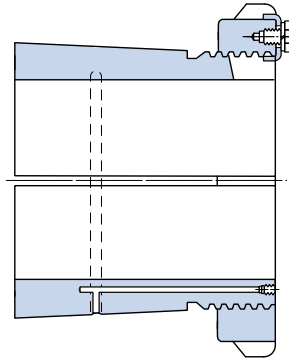

OH .. HE

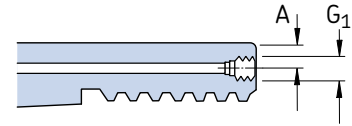

Dimensions										Mass	Designations	Appertaining lock nut		Appropriate hydraulic nut
d_1	d	d_3	B_1	B_2	B_3	G	G_1	A		Adapter sleeve with nut and locking device	lock nut	locking device		
mm										kg	–			
470	500	580	208	68	85	Tr 500×5	M 8	6,5	74,3	OH 39/500 H	HM 30/500	MS 30/500-96	HMV 100 E	
	500	580	208	68	85	Tr 500×5	M 8	6,5	74,3	OH 39/500 HE	HME 30/500	MS 30/500-96	HMV 100 E	
	500	580	247	68	85	Tr 500×5	M 8	6,5	82,0	OH 30/500 H	HM 30/500	MS 30/500-96	HMV 100 E	
	500	630	356	80	100	Tr 500×5	M 8	6,5	145	OH 31/500 H	HM 31/500	MS 31/500	HMV 100 E	
	500	630	428	80	100	Tr 500×5	M 8	6	170	OH 32/500 H	HM 31/500	MS 31/500	HMV 100 E	
500	530	630	216	68	90	Tr 530×6	M 8	6	87,9	OH 39/530 H	HM 30/530	MS 30/600-530	HMV 106 E	
	530	630	216	68	90	Tr 530×6	M 8	6	87,9	OH 39/530 HE	HME 30/530	MS 30/600-530	HMV 106 E	
	530	630	265	68	90	Tr 530×6	M 8	6	105	OH 30/530 H	HM 30/530	MS 30/600-530	HMV 106 E	
	530	670	364	80	105	Tr 530×6	M 8	6	161	OH 31/530 H	HM 31/530	MS 31/530	HMV 106 E	
	530	670	447	80	105	Tr 530×6	M 8	6	192	OH 32/530 H	HM 31/530	MS 31/530	HMV 106 E	
530	560	650	227	75	97	Tr 560×6	M 8	6	95,0	OH 39/560 H	HM 30/560	MS 30/560	HMV 112 E	
	560	650	227	75	97	Tr 560×6	M 8	6	95,0	OH 39/560 HE	HME 30/560	MS 30/560	HMV 112 E	
	560	650	282	75	97	Tr 560×6	M 8	6	112	OH 30/560 H	HM 30/560	MS 30/560	HMV 112 E	
	560	710	377	85	110	Tr 560×6	M 8	6	185	OH 31/560 H	HM 31/560	MS 31/600-560	HMV 112 E	
	560	710	462	85	110	Tr 560×6	M 8	6	219	OH 32/560 H	HM 31/560	MS 31/600-560	HMV 112 E	
560	600	700	239	75	97	Tr 600×6	G 1/8	8	127	OH 39/600 H	HM 30/600	MS 30/600-530	HMV 120 E	
	600	700	239	75	97	Tr 600×6	G 1/8	8	127	OH 39/600 HE	HME 30/600	MS 30/600-530	HMV 120 E	
	600	700	289	75	97	Tr 600×6	G 1/8	8	147	OH 30/600 H	HM 30/600	MS 30/600-530	HMV 120 E	
	600	750	399	85	110	Tr 600×6	G 1/8	8	234	OH 31/600 H	HM 31/600	MS 31/600-560	HMV 120 E	
	600	750	487	85	110	Tr 600×6	G 1/8	8	278	OH 32/600 H	HM 31/600	MS 31/600-560	HMV 120 E	
600	630	730	254	75	97	Tr 630×6	M 8	6	124	OH 39/630 H	HM 30/630	MS 30/630	HMV 126 E	
	630	730	254	75	97	Tr 630×6	M 8	6	124	OH 39/630 HE	HME 30/630	MS 30/630	HMV 126 E	
	630	730	301	75	97	Tr 630×6	M 8	6	138	OH 30/630 H	HM 30/630	MS 30/630	HMV 126 E	
	630	800	424	95	120	Tr 630×6	M 8	6	254	OH 31/630 H	HM 31/630	MS 31/630	HMV 126 E	
630	670	780	264	80	102	Tr 670×6	G 1/8	8	162	OH 39/670 H	HM 30/670	MS 30/670	HMV 134 E	
	670	780	324	80	102	Tr 670×6	G 1/8	8	190	OH 30/670 H	HM 30/670	MS 30/670	HMV 134 E	
	670	850	456	106	131	Tr 670×6	G 1/8	8	340	OH 31/670 H	HM 31/670	MS 31/670	HMV 134 E	
	670	850	558	106	131	Tr 670×6	G 1/8	8	401	OH 32/670 H	HM 31/670	MS 31/670	HMV 134 E	
670	710	830	286	90	112	Tr 710×7	G 1/8	8	183	OH 39/710 H	HM 30/710	MS 30/710	HMV 142 E	
	710	830	286	90	112	Tr 710×7	G 1/8	8	183	OH 39/710 HE	HME 30/710	MS 30/710	HMV 142 E	
	710	830	342	90	112	Tr 710×7	G 1/8	8	228	OH 30/710 H	HM 30/710	MS 30/710	HMV 142 E	
	710	900	467	106	135	Tr 710×7	G 1/8	8	392	OH 31/710 H	HM 31/710	MS 31/710	HMV 142 E	
	710	900	572	106	135	Tr 710×7	G 1/8	8	459	OH 32/710 H	HM 31/710	MS 31/710	HMV 142 E	

For OH .. HE sleeves not listed in the table, please contact SKF

Dimensions										Mass	Designations Adapter sleeve with nut and locking device	Appertaining lock nut	locking device	Appropriate hydraulic nut
d ₁	d	d ₃	B ₁	B ₂	B ₃	G	G ₁	A						
mm										kg	–			
710	750	870	291	90	112	Tr 750×7	G 1/8	8	211	OH 39/750 H	HM 30/750	MS 30/800-750	HMV 150 E	
	750	870	291	90	112	Tr 750×7	G 1/8	8	211	OH 39/750 HE	HME 30/750	MS 30/800-750	HMV 150 E	
	750	870	356	90	112	Tr 750×7	G 1/8	8	246	OH 30/750 H	HM 30/750	MS 30/800-750	HMV 150 E	
	750	950	493	112	141	Tr 750×7	G 1/8	8	451	OH 31/750 H	HM 31/750	MS 31/800-750	HMV 150 E	
	750	950	603	112	141	Tr 750×7	G 1/8	8	526	OH 32/750 H	HM 31/750	MS 31/800-750	HMV 150 E	
750	800	920	303	90	112	Tr 800×7	G 1/8	10	259	OH 39/800 H	HM 30/800	MS 30/800-750	HMV 160 E	
	800	920	303	90	112	Tr 800×7	G 1/8	10	259	OH 39/800 HE	HME 30/800	MS 30/800-750	HMV 160 E	
	800	920	366	90	112	Tr 800×7	G 1/8	10	302	OH 30/800 H	HM 30/800	MS 30/800-750	HMV 160 E	
	800	1 000	505	112	141	Tr 800×7	G 1/8	10	535	OH 31/800 H	HM 31/800	MS 31/800-750	HMV 160 E	
800	850	980	308	90	115	Tr 850×7	G 1/8	10	288	OH 39/850 H	HM 30/850	MS 30/900-850	HMV 170 E	
	850	980	308	90	115	Tr 850×7	G 1/8	10	288	OH 39/850 HE	HME 30/850	MS 30/900-850	HMV 170 E	
	850	980	380	90	115	Tr 850×7	G 1/8	10	341	OH 30/850 H	HM 30/850	MS 30/900-850	HMV 170 E	
	850	1 060	536	118	147	Tr 850×7	G 1/8	10	616	OH 31/850 H	HM 31/850	MS 31/850	HMV 170 E	
850	900	1 030	326	100	125	Tr 900×7	G 1/8	10	330	OH 39/900 H	HM 30/900	MS 30/900-850	HMV 180 E	
	900	1 030	326	100	125	Tr 900×7	G 1/8	10	330	OH 39/900 HE	HME 30/900	MS 30/900-850	HMV 180 E	
	900	1 030	400	100	125	Tr 900×7	G 1/8	10	387	OH 30/900 H	HM 30/900	MS 30/900-850	HMV 180 E	
	900	1 120	557	125	154	Tr 900×7	G 1/8	10	677	OH 31/900 H	HM 31/900	MS 31/850	HMV 180 E	
900	950	1 080	344	100	125	Tr 950×8	G 1/8	10	363	OH 39/950 H	HM 30/950	MS 30/950	HMV 190 E	
	950	1 080	420	100	125	Tr 950×8	G 1/8	10	424	OH 30/950 H	HM 30/950	MS 30/950	HMV 190 E	
	950	1 170	583	125	154	Tr 950×8	G 1/8	10	738	OH 31/950 H	HM 31/950	MS 31/950	HMV 190 E	
950	1 000	1 140	358	100	125	Tr 1000×8	G 1/8	10	407	OH 39/1000 H	HM 30/1000	MS 30/1000	HMV 200 E	
	1 000	1 140	430	100	125	Tr 1000×8	G 1/8	10	470	OH 30/1000 H	HM 30/1000	MS 30/1000	HMV 200 E	
	1 000	1 240	609	100	154	Tr 1000×8	G 1/8	10	842	OH 31/1000 H	HM 31/1000	MS 31/1000	HMV 200 E	
1 000	1 060	1 200	372	100	125	Tr 1060×8	G 1/8	12	490	OH 39/1060 H	HM 30/1060	MS 30/1000	HMV 212 E	
	1 060	1 200	447	100	125	Tr 1060×8	G 1/8	12	571	OH 30/1060 H	HM 30/1060	MS 30/1000	HMV 212 E	
	1 060	1 300	622	125	154	Tr 1060×8	G 1/8	12	984	OH 31/1060 H	HM 31/1060	MS 31/1000	HMV 212 E	

For OH .. HE sleeves not listed in the table, please contact SKF

Adapter sleeves for inch shafts

d_1 3/4 – 2 3/16 in

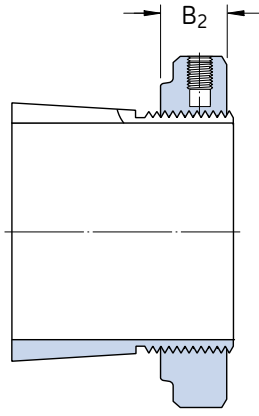
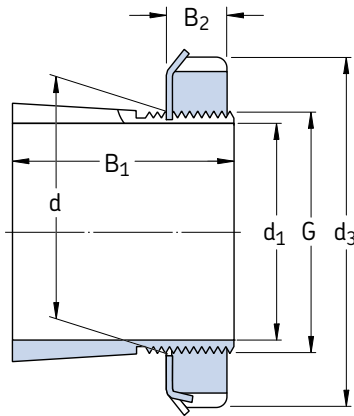

HA, HE, HS

HA .. E, HE .. E, HS .. E

Dimensions							Mass	Designations	Appertaining lock nut locking device	
d_1	d	d_3	B_1	B_2	G		Adapter sleeve with nut and locking device			
in	mm						kg	–		
3/4	19,050	25	38	26	8	M 25×1,5	0,070	HE 205	KM 5	MB 5
		25	38	29	8	M 25×1,5	0,080	HE 305	KM 5	MB 5
		25	38	29	10,5	M 25×1,5	0,088	HE 305 E	KMFE 5	–
		25	38	35	8	M 25×1,5	0,090	HE 2305	KM 5	MB 5
7/8	22,225	30	45	27	8	M 30×1,5	0,11	HS 206	KM 6	MB 6
		30	45	31	8	M 30×1,5	0,12	HS 306	KM 6	MB 6
15/16	23,813	30	45	27	8	M 30×1,5	0,10	HA 206	KM 6	MB 6
		30	45	31	8	M 30×1,5	0,12	HA 306	KM 6	MB 6
		30	45	31	10,5	M 30×1,5	0,13	HA 306 E	KMFE 6	–
		30	45	38	8	M 30×1,5	0,13	HA 2306	KM 6	MB 6
1	25,400	30	45	27	8	M 30×1,5	0,080	HE 206	KM 6	MB 6
		30	45	31	8	M 30×1,5	0,10	HE 306	KM 6	MB 6
		30	45	31	10,5	M 30×1,5	0,11	HE 306 E	KMFE 6	–
		30	45	38	8	M 30×1,5	0,11	HE 2306	KM 6	MB 6
1 1/8	28,575	35	52	29	9	M 35×1,5	0,14	HS 207	KM 7	MB 7
		35	52	35	9	M 35×1,5	0,16	HS 307	KM 7	MB 7
		35	52	35	11,5	M 35×1,5	0,17	HS 307 E	KMFE 7	–
1 3/16	30,163	35	52	29	9	M 35×1,5	0,12	HA 207	KM 7	MB 7
		35	52	35	9	M 35×1,5	0,14	HA 307	KM 7	MB 7
		35	52	35	11,5	M 35×1,5	0,15	HA 307 E	KMFE 7	–
		35	52	43	9	M 35×1,5	0,16	HA 2307	KM 7	MB 7
1 1/4	31,750	40	58	31	10	M 40×1,5	0,19	HE 208	KM 8	MB 8
		40	58	36	10	M 40×1,5	0,22	HE 308	KM 8	MB 8
		40	58	36	13	M 40×1,5	0,19	HE 308 E	KMFE 8	–
		40	58	46	10	M 40×1,5	0,28	HE 2308	KM 8	MB 8
1 3/8	34,925	40	58	31	10	M 40×1,5	0,16	HS 208	KM 8	MB 8
		40	58	36	10	M 40×1,5	0,17	HS 308	KM 8	MB 8
1 7/16	36,512	45	65	33	11	M 45×1,5	0,26	HA 209	KM 9	MB 9
		45	65	39	11	M 45×1,5	0,29	HA 309	KM 9	MB 9
		45	65	39	13	M 45×1,5	0,31	HA 309 E	KMFE 9	–
		45	65	50	11	M 45×1,5	0,35	HA 2309	KM 9	MB 9

Dimensions							Mass	Designations Adapter sleeve with nut and locking device	Appertaining lock nut	locking device	Appropriate hydraulic nut
d ₁	d	d ₃	B ₁	B ₂	G						
in	mm						kg	–			
1 1/2	38,100	45	65	33	11	M 45×1,5	0,20	HE 209	KM 9	MB 9	–
		45	65	39	11	M 45×1,5	0,24	HE 309	KM 9	MB 9	–
		45	65	39	13	M 45×1,5	0,26	HE 309 E	KMFE 9	–	–
		45	65	50	11	M 45×1,5	0,31	HE 2309	KM 9	MB 9	–
1 5/8	41,275	50	70	35	12	M 50×1,5	0,31	HS 210	KM 10	MB 10	HMV 10 E
		50	70	42	12	M 50×1,5	0,36	HS 310	KM 10	MB 10	HMV 10 E
		50	70	55	12	M 50×1,5	0,40	HS 2310	KM 10	MB 10	HMV 10 E
1 11/16	42,863	50	70	35	12	M 50×1,5	0,28	HA 210	KM 10	MB 10	HMV 10 E
		50	70	42	12	M 50×1,5	0,32	HA 310	KM 10	MB 10	HMV 10 E
		50	70	42	14	M 50×1,5	0,32	HA 310 E	KMFE 10	–	HMV 10 E
		50	70	55	12	M 50×1,5	0,40	HA 2310	KM 10	MB 10	HMV 10 E
1 3/4	44,450	50	70	35	12	M 50×1,5	0,26	HE 210	KM 10	MB 10	HMV 10 E
		50	70	42	12	M 50×1,5	0,29	HE 310	KM 10	MB 10	HMV 10 E
		50	70	42	14	M 50×1,5	0,29	HE 310 E	KMFE 10	–	HMV 10 E
		50	70	55	12	M 50×1,5	0,36	HE 2310	KM 10	MB 10	HMV 10 E
1 7/8	47,625	55	75	37	12,5	M 55×2	0,33	HS 211	KM 11	MB 11	HMV 11 E
		55	75	45	12,5	M 55×2	0,38	HS 311	KM 11	MB 11	HMV 11 E
1 15/16	49,213	55	75	37	12,5	M 55×2	0,30	HA 211	KM 11	MB 11	HMV 11 E
		55	75	45	12,5	M 55×2	0,34	HA 311	KM 11	MB 11	HMV 11 E
		55	75	45	14	M 55×2	0,35	HA 311 E	KMFE 11	–	HMV 11 E
		55	75	59	12,5	M 55×2	0,42	HA 2311	KM 11	MB 11	HMV 11 E
2	50,800	55	75	37	12,5	W 55×1/19	0,26	HE 211 B	HM 11	MB 11	–
		55	75	45	12,5	W 55×1/19	0,29	HE 311 B	HM 11	MB 11	–
		55	75	45	14	W 55×1/19	0,30	HE 311 BE	KMFE 11 B	–	–
		55	75	59	12,5	W 55×1/19	0,36	HE 2311 B	HM 11	MB 11	–
2 1/8	53,975	60	80	38	12,5	M 60×2	0,35	HS 212	KM 12	MB 12	HMV 12 E
		60	80	47	12,5	M 60×2	0,40	HS 312	KM 12	MB 12	HMV 12 E
		60	80	47	14	M 60×2	0,41	HS 312 E	KMFE 12	–	HMV 12 E
		60	80	62	12,5	M 60×2	0,49	HS 2312	KM 12	MB 12	HMV 12 E
2 3/16	55,563	65	85	40	13,5	M 65×2	0,49	HA 213	KM 13	MB 13	HMV 13 E
		65	85	50	13,5	M 65×2	0,58	HA 313	KM 13	MB 13	HMV 13 E
		65	85	50	15	M 65×2	0,59	HA 313 E	KMFE 13	–	HMV 13 E
		65	85	65	13,5	M 65×2	0,75	HA 2313	KM 13	MB 13	HMV 13 E

Adapter sleeves for inch shafts

d_1 2 1/4 – 4 3/16 in

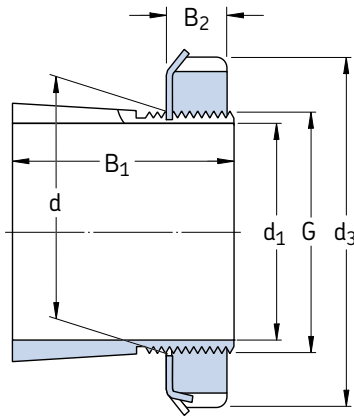

HA, HE, HS

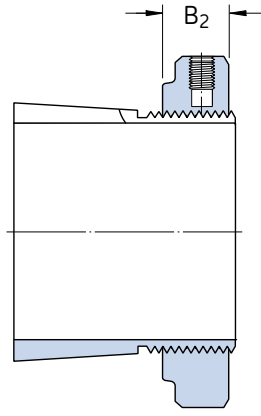

HA .. E, HE .. E

Dimensions							Mass	Designations Adapter sleeve with nut and locking device	Appertaining lock nut	locking device	Appropriate hydraulic nut
d_1	d	d_3	B_1	B_2	G						
in	mm					kg	–				
2 1/4	57,150	65	85	40	13,5	M 65x2	0,44	HE 213	KM 13	MB 13	HMV 13 E
		65	85	50	13,5	M 65x2	0,52	HE 313	KM 13	MB 13	HMV 13 E
		65	85	50	15	M 65x2	0,53	HE 313 E	KMFE 13	–	HMV 13 E
		65	85	65	13,5	M 65x2	0,65	HE 2313	KM 13	MB 13	HMV 13 E
2 3/8	60,325	65	85	40	13,5	M 65x2	0,44	HS 213	KM 13	MB 13	HMV 13 E
		65	85	50	13,5	M 65x2	0,71	HS 313	KM 13	MB 13	HMV 13 E
		65	85	65	13,5	M 65x2	0,80	HS 2313	KM 13	MB 13	HMV 13 E
2 7/16	61,913	75	98	43	14,5	M 75x2	0,75	HA 215	KM 15	MB 15	HMV 15 E
		75	98	55	14,5	M 75x2	0,91	HA 315	KM 15	MB 15	HMV 15 E
		75	98	55	16	M 75x2	0,93	HA 315 E	KMFE 15	–	HMV 15 E
		75	98	73	14,5	M 75x2	1,15	HA 2315	KM 15	MB 15	HMV 15 E
2 1/2	63,500	75	98	43	14,5	M 75x2	0,70	HE 215	KM 15	MB 15	HMV 15 E
		75	98	55	14,5	M 75x2	0,85	HE 315	KM 15	MB 15	HMV 15 E
		75	98	55	16	M 75x2	0,87	HE 315 E	KMFE 15	–	HMV 15 E
		75	98	73	14,5	M 75x2	1,09	HE 2315	KM 15	MB 15	HMV 15 E
2 5/8	66,675	75	98	43	14,5	M 75x2	0,70	HS 215	KM 15	MB 15	HMV 15 E
		75	98	55	14,5	M 75x2	0,71	HS 315	KM 15	MB 15	HMV 15 E
		75	98	73	14,5	M 75x2	0,90	HS 2315	KM 15	MB 15	HMV 15 E
2 11/16	68,263	80	105	46	17	M 80x2	0,87	HA 216	KM 16	MB 16	HMV 16 E
		80	105	59	17	M 80x2	1,05	HA 316	KM 16	MB 16	HMV 16 E
		80	105	59	18	M 80x2	1,06	HA 316 E	KMFE 16	–	HMV 16 E
		80	105	78	17	M 80x2	1,30	HA 2316	KM 16	MB 16	HMV 16 E
2 3/4	69,850	80	105	46	17	M 80x2	0,81	HE 216	KM 16	MB 16	HMV 16 E
		80	105	59	17	M 80x2	0,97	HE 316	KM 16	MB 16	HMV 16 E
		80	105	59	18	M 80x2	0,98	HE 316 E	KMFE 16	–	HMV 16 E
		80	105	78	17	M 80x2	1,20	HE 2316	KM 16	MB 16	HMV 16 E
2 15/16	74,613	85	110	50	18	M 85x2	0,94	HA 217	KM 17	MB 17	HMV 17 E
		85	110	63	18	M 85x2	1,10	HA 317	KM 17	MB 17	HMV 17 E
		85	110	63	19	M 85x2	1,19	HA 317 E	KMFE 17	–	HMV 17 E
		85	110	82	18	M 85x2	1,40	HA 2317	KM 17	MB 17	HMV 17 E
3	76,200	85	110	50	18	M 85x2	0,87	HE 217	KM 17	MB 17	HMV 17 E
		85	110	63	18	M 85x2	1,00	HE 317	KM 17	MB 17	HMV 17 E
		85	110	63	19	M 85x2	0,99	HE 317 E	KMFE 17	–	HMV 17 E
		85	110	82	18	M 85x2	1,30	HE 2317	KM 17	MB 17	HMV 17 E

Dimensions						Mass	Designations	Appertaining lock nut	locking device	Appropriate hydraulic nut	
d ₁	d	d ₃	B ₁	B ₂	G		Adapter sleeve with nut and locking device				
in	mm					kg	–				
3 3/16	80,963	90	120	52	18	M 90×2	1,05	HA 218	KM 18	MB 18	HMV 18 E
		90	120	65	18	M 90×2	1,25	HA 318	KM 18	MB 18	HMV 18 E
		90	120	65	19	M 90×2	1,26	HA 318 E	KMFE 18	–	HMV 18 E
		90	120	86	18	M 90×2	1,50	HA 2318	KM 18	MB 18	HMV 18 E
3 1/4	82,550	90	120	52	18	M 90×2	0,97	HE 218	KM 18	MB 18	HMV 18 E
		90	120	65	18	M 90×2	1,10	HE 318	KM 18	MB 18	HMV 18 E
		90	120	65	19	M 90×2	1,11	HE 318 E	KMFE 18	–	HMV 18 E
		90	120	86	18	M 90×2	1,40	HE 2318	KM 18	MB 18	HMV 18 E
		95	125	55	19	M 95×2	1,35	HE 219	KM 19	MB 19	HMV 19 E
		95	125	68	19	M 95×2	1,60	HE 319	KM 19	MB 19	HMV 19 E
		95	125	68	20	M 95×2	1,61	HE 319 E	KMFE 19	–	HMV 19 E
		95	125	90	19	M 95×2	2,00	HE 2319	KM 19	MB 19	HMV 19 E
3 7/16	87,313	100	130	58	20	M 100×2	1,55	HA 220	KM 20	MB 20	HMV 20 E
		100	130	71	20	M 100×2	1,80	HA 320	KM 20	MB 20	HMV 20 E
		100	130	71	21	M 100×2	1,75	HA 320 E	KMFE 20	–	HMV 20 E
		100	130	97	20	M 100×2	2,35	HA 2320	KM 20	MB 20	HMV 20 E
3 1/2	88,900	100	130	58	20	M 100×2	1,45	HE 220	KM 20	MB 20	HMV 20 E
		100	130	71	20	M 100×2	1,75	HE 320	KM 20	MB 20	HMV 20 E
		100	130	71	21	M 100×2	1,70	HE 320 E	KMFE 20	–	HMV 20 E
		100	130	76	20	M 100×2	1,80	HE 3120	KM 20	MB 20	HMV 20 E
		100	130	97	20	M 100×2	2,20	HE 2320	KM 20	MB 20	HMV 20 E
4	101,600	110	145	63	21	M 110×2	1,65	HE 222	KM 22	MB 22	HMV 22 E
		110	145	77	21	M 110×2	1,90	HE 322	KM 22	MB 22	HMV 22 E
		110	145	77	21,5	M 110×2	1,85	HE 322 E	KMFE 22	–	HMV 22 E
		110	145	81	21	M 110×2	2,25	HE 3122	KM 22	MB 22	HMV 22 E
		110	145	105	21	M 110×2	2,40	HE 2322	KM 22	MB 22	HMV 22 E
4 3/16	106,363	120	145	72	22	M 120×2	2,25	HA 3024	KML 24	MBL 24	HMV 24 E
		120	155	72	26	M 120×2	2,32	HA 3024 E	KMFE 24	–	HMV 24 E
		120	155	88	22	M 120×2	2,90	HA 3124	KM 24	MB 24	HMV 24 E
		120	145	88	22	M 120×2	2,60	HA 3124 L	KML 24	MBL 24	HMV 24 E
		120	155	112	22	M 120×2	3,60	HA 2324	KM 24	MB 24	HMV 24 E
		120	145	112	22	M 120×2	3,30	HA 2324 L	KML 24	MBL 24	HMV 24 E

Adapter sleeves for inch shafts

d_1 4 1/4 – 7 3/16 in

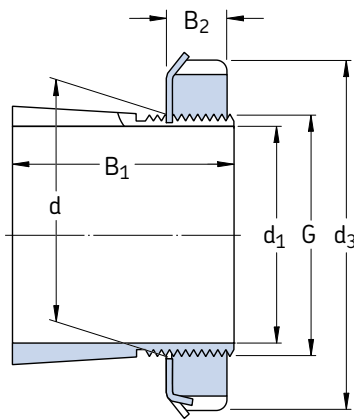

HA, HA .. L, HE, HE .. L

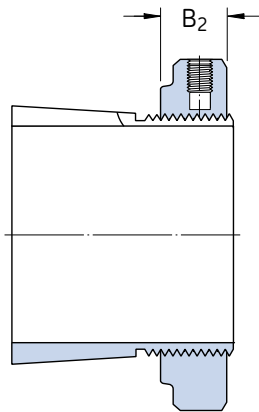

HA .. E, HE .. E

Dimensions						Mass	Designations Adapter sleeve with nut and locking device	Appertaining lock nut	locking device	Appropriate hydraulic nut	
d_1	d	d_3	B_1	B_2	G						
in	mm					kg	–				
4 1/4	107,950	120	145	72	22	M 120x2	2,00	HE 3024	KML 24	MBL 24	HMV 24 E
		120	155	72	26	M 120x2	2,70	HE 3024 E	KMFE 24	–	HMV 24 E
		120	155	88	22	M 120x2	2,80	HE 3124	KM 24	MB 24	HMV 24 E
		120	155	112	22	M 120x2	3,35	HE 2324	KM 24	MB 24	HMV 24 E
		120	145	112	22	M 120x2	3,05	HE 2324 L	KML 24	MBL 24	HMV 24 E
4 7/16	112,713	130	155	80	23	M 130x2	3,05	HA 3026	KML 26	MBL 26	HMV 26 E
		130	165	92	23	M 130x2	3,75	HA 3126	KM 26	MB 26	HMV 26 E
		130	155	92	23	M 130x2	3,55	HA 3126 L	KML 26	MBL 26	HMV 26 E
		130	165	92	28	M 130x2	3,77	HA 3126 E	KMFE 26	–	HMV 26 E
		130	165	121	23	M 130x2	4,74	HA 2326	KM 26	MB 26	HMV 26 E
4 1/2	114,300	130	155	80	23	M 130x2	2,90	HE 3026	KML 26	MBL 26	HMV 26 E
		130	165	92	23	M 130x2	3,60	HE 3126	KM 26	MB 26	HMV 26 E
		130	155	92	23	M 130x2	3,40	HE 3126 L	KML 26	MBL 26	HMV 26 E
		130	165	121	23	M 130x2	4,55	HE 2326	KM 26	MB 26	HMV 26 E
4 5/16	125,413	140	165	82	24	M 140x2	3,00	HA 3028	KML 28	MBL 28	HMV 28 E
		140	180	97	24	M 140x2	4,10	HA 3128	KM 28	MB 28	HMV 28 E
		140	165	97	24	M 140x2	4,60	HA 3128 L	KML 28	MBL 28	HMV 28 E
		140	180	131	24	M 140x2	5,30	HA 2328	KM 28	MB 28	HMV 28 E
5	127,000	140	165	82	24	M 140x2	2,80	HE 3028	KML 28	MBL 28	HMV 28 E
		140	180	97	24	M 140x2	3,80	HE 3128	KM 28	MB 28	HMV 28 E
		140	165	97	24	M 140x2	3,30	HE 3128 L	KML 28	MBL 28	HMV 28 E
		140	180	131	24	M 140x2	5,00	HE 2328	KM 28	MB 28	HMV 28 E
5 3/16	131,763	150	180	87	26	M 150x2	4,20	HA 3030	KML 30	MBL 30	HMV 30 E
		150	195	111	26	M 150x2	5,80	HA 3130	KM 30	MB 30	HMV 30 E
		150	180	111	26	M 150x2	5,30	HA 3130 L	KML 30	MBL 30	HMV 30 E
		150	195	139	26	M 150x2	7,10	HA 2330	KM 30	MB 30	HMV 30 E
5 1/4	133,350	150	180	87	26	M 150x2	4,00	HE 3030	KML 30	MBL 30	HMV 30 E
		150	195	111	26	M 150x2	5,50	HE 3130	KM 30	MB 30	HMV 30 E
		150	180	111	26	M 150x2	5,00	HE 3130 L	KML 30	MBL 30	HMV 30 E
		150	195	139	26	M 150x2	6,80	HE 2330	KM 30	MB 30	HMV 30 E
5 7/16	138,113	160	190	93	27,5	M 160x3	5,40	HA 3032	KML 32	MBL 32	HMV 32 E
		160	210	119	27,5	M 160x3	7,55	HA 3132	KM 32	MB 32	HMV 32 E
		160	210	147	27,5	M 160x3	9,40	HA 2332	KM 32	MB 32	HMV 32 E
		160	190	147	27,5	M 160x3	8,55	HA 2332 L	KML 32	MBL 32	HMV 32 E

Dimensions							Mass	Designations	Appertaining lock nut locking device		Appropriate hydraulic nut
d ₁	d	d ₃	B ₁	B ₂	G		Adapter sleeve with nut and locking device				
in	mm						kg	–			
5 1/2	139,700	160	190	93	27,5	M 160×3	5,10	HE 3032	KML 32	MBL 32	HMV 32 E
		160	210	119	27,5	M 160×3	7,30	HE 3132	KM 32	MB 32	HMV 32 E
		160	190	119	27,5	M 160×3	6,45	HE 3132 L	KML 32	MBL 32	HMV 32 E
		160	210	147	27,5	M 160×3	8,80	HE 2332	KM 32	MB 32	HMV 32 E
		160	190	147	27,5	M 160×3	7,95	HE 2332 L	KML 32	MBL 32	HMV 32 E
5 15/16	150,813	170	200	101	28,5	M 170×3	5,70	HA 3034	KML 34	MBL 34	HMV 34 E
		170	220	122	28,5	M 170×3	7,80	HA 3134	KM 34	MB 34	HMV 34 E
		170	200	122	28,5	M 170×3	6,80	HA 3134 L	KML 34	MBL 34	HMV 34 E
		170	220	154	28,5	M 170×3	9,60	HA 2334	KM 34	MB 34	HMV 34 E
6	152,400	170	200	101	28,5	M 170×3	5,40	HE 3034	KML 34	MBL 34	HMV 34 E
		170	220	122	28,5	M 170×3	7,55	HE 3134	KM 34	MB 34	HMV 34 E
		170	200	122	28,5	M 170×3	6,60	HE 3134 L	KML 34	MBL 34	HMV 34 E
		170	220	154	28,5	M 170×3	9,20	HE 2334	KM 34	MB 34	HMV 34 E
6 7/16	163,513	180	210	109	29,5	M 180×3	6,00	HA 3036	KML 36	MBL 36	HMV 36 E
		180	230	131	29,5	M 180×3	8,15	HA 3136	KM 36	MB 36	HMV 36 E
		180	210	131	29,5	M 180×3	7,20	HA 3136 L	KML 36	MBL 36	HMV 36 E
		180	230	161	29,5	M 180×3	9,90	HA 2336	KM 36	MB 36	HMV 36 E
6 1/2	165,100	180	210	109	29,5	M 180×3	5,55	HE 3036	KML 36	MBL 36	HMV 36 E
		180	230	131	29,5	M 180×3	7,80	HE 3136	KM 36	MB 36	HMV 36 E
		180	210	131	29,5	M 180×3	6,85	HE 3136 L	KML 36	MBL 36	HMV 36 E
		180	230	161	29,5	M 180×3	9,35	HE 2336	KM 36	MB 36	HMV 36 E
6 3/4	171,450	190	220	112	30,5	M 190×3	7,20	HE 3038	KML 38	MBL 38	HMV 38 E
		190	240	141	30,5	M 190×3	10,2	HE 3138	KM 38	MB 38	HMV 38 E
		190	240	169	30,5	M 190×3	11,7	HE 2338	KM 38	MB 38	HMV 38 E
6 15/16	176,213	190	220	112	30,5	M 190×3	5,80	HA 3038	KML 38	MBL 38	HMV 38 E
		190	240	141	30,5	M 190×3	8,50	HA 3138	KM 38	MB 38	HMV 38 E
		190	240	169	30,5	M 190×3	10,0	HA 2338	KM 38	MB 38	HMV 38 E
7	177,800	200	240	120	31,5	M 200×3	9,35	HE 3040	KML 40	MBL 40	HMV 40 E
		200	250	150	31,5	M 200×3	12,3	HE 3140	KM 40	MB 40	HMV 40 E
		200	250	176	31,5	M 200×3	14,2	HE 2340	KM 40	MB 40	HMV 40 E
7 3/16	182,563	200	240	120	31,5	M 200×3	8,25	HA 3040	KML 40	MBL 40	HMV 40 E
		200	250	150	31,5	M 200×3	11,2	HA 3140	KM 40	MB 40	HMV 40 E
		200	250	176	31,5	M 200×3	12,6	HA 2340	KM 40	MB 40	HMV 40 E



Withdrawal sleeves

Designs	996
Basic design.....	996
Design for oil injection.....	996
Product data – general.....	997
Dimensions.....	997
Tolerances.....	997
Thread	997
Shaft tolerances.....	997
Product table	998

Designs

Withdrawal sleeves can be used to mount bearings with a tapered bore on cylindrical seatings of stepped shafts (→ **fig. 1**). The sleeve is pressed into the bore of the bearing that abuts a shaft shoulder or similar fixed component. The sleeve is located on the shaft by a nut or an end plate. Lock nuts or end plates are not supplied with the withdrawal sleeves. KM or HM lock nuts (→ **page 1010**) and respective locking washers are suitable but must be ordered separately.

To secure the bearing to the shaft, press the withdrawal sleeve into the bearing bore. To do this, particularly where larger bearings are concerned, considerable force is required to overcome the friction between the mating surfaces of the bearing and sleeve and of the sleeve and shaft. Mounting and dismounting of bearings on withdrawal sleeves can be facilitated considerably by using a hydraulic nut (→ **fig. 2**).

Basic design

SKF withdrawal sleeves (→ **fig. 3**) are coated with a solventless rust inhibitor. They are slotted and have an external taper of 1:12 except for those in the A(O)H 240 and A(O)H 241 series which have an external taper of 1:30 and are intended for use with wide bearings in the 40 and 41 Dimension Series.

The nuts required for dismounting the withdrawal sleeve are not supplied with the sleeve and must be ordered separately. Appropriate sizes are listed in the product table. Appropriate hydraulic nuts for dismounting are listed there as well.

Design for oil injection

To enable the oil injection method to be used for mounting and dismounting, SKF withdrawal sleeves with bore diameters of 200 mm and above are produced as standard with oil supply ducts and distributor grooves (→ **fig. 4**). These AOH sleeves have two oil supply ducts at the threaded side as well as oil distributor grooves in the circumferential and axial directions, both in the outside surface and the sleeve bore. If oil is injected through these ducts and grooves, an oil film is formed between the mating surfaces of the bearing and sleeve and between the shaft and sleeve, and the force required to mount the bearing is considerably reduced. Details of the thread for attaching the oil supply lead to the ducts as well as of appropriate hydraulic nuts can be found in the product table.

The equipment required for the oil injection method is also supplied by SKF (→ section “Maintenance and lubrication products”, starting on **page 1069**).

Fig. 1

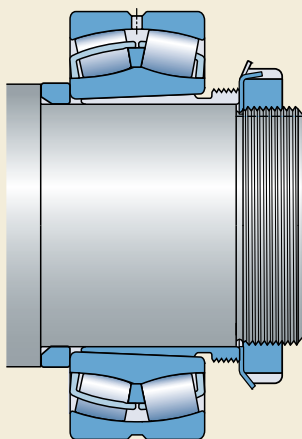
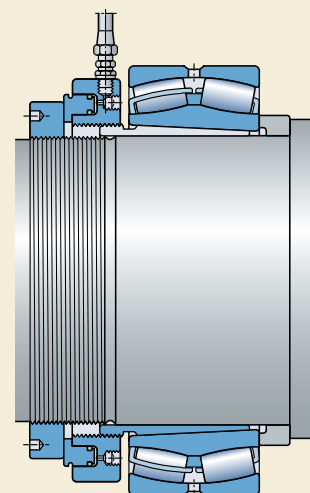

Fig. 2



Product data – general

Dimensions

The dimensions of SKF withdrawal sleeves are in accordance with ISO 2982-1:1995.

Tolerances

The bore diameter of SKF withdrawal sleeves is to tolerance JS9, the width to h13.

Thread

SKF withdrawal sleeves up to size 38 have metric threads with 6g tolerances according to ISO 965-3:1998. Larger withdrawal sleeves have metric trapezoidal threads with 7e tolerance according to ISO 2903:1993.

If standard nuts are not used, the threads of nuts for withdrawal sleeves up to size 38 should correspond to tolerance 5H according to ISO 965-3:1998. The threads of nuts for larger withdrawal sleeves should correspond to tolerance 7H according to ISO 2903:1993.

Shaft tolerances

As withdrawal sleeves adapt themselves to the shaft diameter, wider diameter tolerances can be permitted than for the seating of a bearing with a cylindrical bore. However, the form tolerances must be kept within narrow limits as the accuracy of form directly affects the running accuracy of the bearing. Generally, shafts should be machined to an h9 tolerance but the cylindricity should be to IT5/2 according to ISO 1101:2004.

Fig. 3

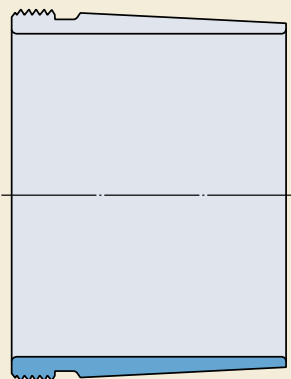
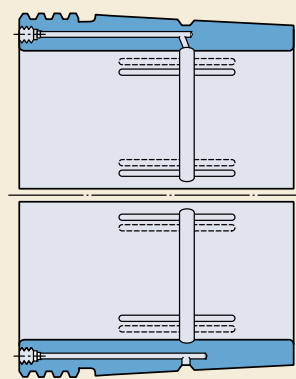
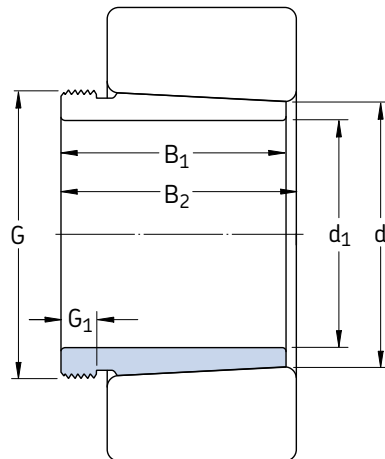

Fig. 4



Withdrawal sleeves

d_1 35 – 145 mm



Dimensions						Mass	Designations	Appropriate nut for dismounting	hydraulic nut
d_1	d	B_1	$B_2^{1)}$	G	G_1		Withdrawal sleeve		
mm						kg	–		
35	40	29	32	M 45×1,5	6	0,09	AH 308	KM 9	–
	40	40	43	M 45×1,5	7	0,13	AH 2308	KM 9	–
40	45	31	34	M 50×1,5	6	0,12	AH 309	KM 10	HMV 10 E
	45	44	47	M 50×1,5	7	0,16	AH 2309	KM 10	HMV 10 E
45	50	35	38	M 55×2	7	0,13	AHX 310	KM 11	HMV 11 E
	50	50	53	M 55×2	9	0,19	AHX 2310	KM 11	HMV 11 E
50	55	37	40	M 60×2	7	0,16	AHX 311	KM 12	HMV 12 E
	55	54	57	M 60×2	10	0,26	AHX 2311	KM 12	HMV 12 E
55	60	40	43	M 65×2	8	0,19	AHX 312	KM 13	HMV 13 E
	60	58	61	M 65×2	11	0,30	AHX 2312	KM 13	HMV 13 E
60	65	42	45	M 70×2	8	0,22	AH 313 G	KM 14	HMV 14 E
	65	61	64	M 70×2	12	0,36	AH 2313 G	KM 14	HMV 14 E
65	70	43	47	M 75×2	8	0,24	AH 314 G	KM 15	HMV 15 E
	70	64	68	M 75×2	12	0,42	AHX 2314 G	KM 15	HMV 15 E
70	75	45	49	M 80×2	8	0,29	AH 315 G	KM 16	HMV 16 E
	75	68	72	M 80×2	12	0,48	AHX 2315 G	KM 16	HMV 16 E
75	80	48	52	M 90×2	8	0,37	AH 316	KM 18	HMV 18 E
	80	71	75	M 90×2	12	0,57	AHX 2316	KM 18	HMV 18 E
80	85	52	56	M 95×2	9	0,43	AHX 317	KM 19	HMV 19 E
	85	74	78	M 95×2	13	0,65	AHX 2317	KM 19	HMV 19 E
85	90	53	57	M 100×2	9	0,46	AHX 318	KM 20	HMV 20 E
	90	63	67	M 100×2	10	0,57	AHX 3218	KM 20	HMV 20 E
	90	79	83	M 100×2	14	0,76	AHX 2318	KM 20	HMV 20 E
90	95	57	61	M 105×2	10	0,54	AHX 319	KM 21	HMV 21 E
	95	85	89	M 105×2	16	0,90	AHX 2319	KM 21	HMV 21 E
95	100	59	63	M 110×2	10	0,58	AHX 320	KM 22	HMV 22 E
	100	64	68	M 110×2	11	0,66	AHX 3120	KM 22	HMV 22 E
	100	73	77	M 110×2	11	0,76	AHX 3220	KM 22	HMV 22 E
	100	90	94	M 110×2	16	1,00	AHX 2320	KM 22	HMV 22 E

¹⁾ Width before the sleeve is driven into the bearing bore

Dimensions						Mass	Designations	Appropriate nut for dismounting	hydraulic nut
d ₁	d	B ₁	B ₂ ¹⁾	G	G ₁		Withdrawal sleeve		
mm						kg	–		
105	110	63	67	M 120×2	12	0,77	AHX 322	KM 24	HMV 24 E
	110	68	72	M 120×2	11	0,76	AHX 3122	KM 24	HMV 24 E
	110	82	86	M 120×2	11	1,00	AHX 3222 G	KM 24	HMV 24 E
	110	98	102	M 120×2	16	1,30	AHX 2322 G	KM 24	HMV 24 E
	110	82	91	M 115×2	13	0,71	AH 24122	KM 23	HMV 23 E
	115	120	60	64	M 130×2	13	0,73	AHX 3024	KM 26
120		75	79	M 130×2	12	0,94	AHX 3124	KM 26	HMV 26 E
120		90	94	M 130×2	13	1,30	AHX 3224 G	KM 26	HMV 26 E
120		105	109	M 130×2	17	1,55	AHX 2324 G	KM 26	HMV 26 E
120		73	82	M 125×2	13	0,70	AH 24024	KM 25	HMV 25 E
120		93	102	M 130×2	13	1,00	AH 24124	KM 26	HMV 26 E
125	130	67	71	M 140×2	14	0,91	AHX 3026	KM 28	HMV 28 E
	130	78	82	M 140×2	12	1,10	AHX 3126	KM 28	HMV 28 E
	130	98	102	M 140×2	15	1,50	AHX 3226 G	KM 28	HMV 28 E
	130	115	119	M 140×2	19	1,85	AHX 2326 G	KM 28	HMV 28 E
	130	83	93	M 135×2	14	0,90	AH 24026	KM 27	HMV 27 E
	130	94	104	M 140×2	14	1,15	AH 24126	KM 28	HMV 28 E
135	140	68	73	M 150×2	14	1,00	AHX 3028	KM 30	HMV 30 E
	140	83	88	M 150×2	14	1,30	AHX 3128	KM 30	HMV 30 E
	140	104	109	M 150×2	15	1,75	AHX 3228 G	KM 30	HMV 30 E
	140	125	130	M 150×2	20	2,25	AHX 2328 G	KM 30	HMV 30 E
	140	83	93	M 145×2	14	0,95	AH 24028	KM 29	HMV 29 E
	140	99	109	M 150×2	14	1,30	AH 24128	KM 30	HMV 30 E
145	150	72	77	M 160×3	15	1,15	AHX 3030	KM 32	HMV 32 E
	150	96	101	M 160×3	15	1,70	AHX 3130 G	KM 32	HMV 32 E
	150	114	119	M 160×3	17	2,10	AHX 3230 G	KM 32	HMV 32 E
	150	135	140	M 160×3	24	2,75	AHX 2330 G	KM 32	HMV 32 E
	150	90	101	M 155×3	15	1,05	AH 24030	KM 31	HMV 31 E
	150	115	126	M 160×3	15	1,55	AH 24130	KM 32	HMV 32 E

¹⁾ Width before the sleeve is driven into the bearing bore

Withdrawal sleeves

d_1 150 – 280 mm

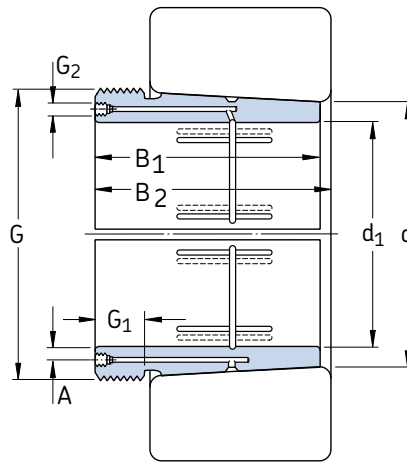
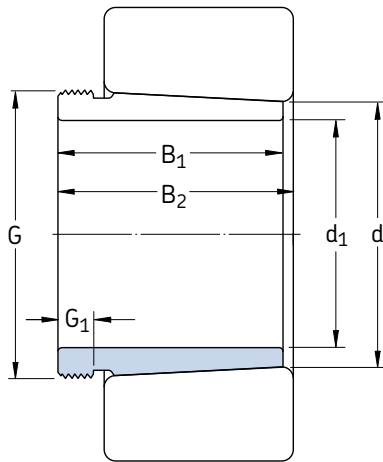

Dimensions						Mass	Designations Withdrawal sleeve	Appropriate nut for dismounting	hydraulic nut	
d_1	d	B_1	$B_2^{1)}$	G	G_1					
mm						kg	–			
150	160	77	82	M 170×3	16	2,00	AH 3032	KM 34	HMV 34 E	
	160	103	108	M 170×3	16	3,00	AH 3132 G	KM 34	HMV 34 E	
	160	124	130	M 170×3	20	3,70	AH 3232 G	KM 34	HMV 34 E	
	160	140	146	M 170×3	24	4,35	AH 2332 G	KM 34	HMV 34 E	
	160	95	106	M 170×3	15	2,30	AH 24032	KM 34	HMV 34 E	
	160	124	135	M 170×3	15	3,00	AH 24132	KM 34	HMV 34 E	
160	170	85	90	M 180×3	17	2,45	AH 3034	KM 36	HMV 36 E	
	170	104	109	M 180×3	16	3,20	AH 3134 G	KM 36	HMV 36 E	
	170	134	140	M 180×3	24	4,35	AH 3234 G	KM 36	HMV 36 E	
	170	146	152	M 180×3	24	4,85	AH 2334 G	KM 36	HMV 36 E	
	170	106	117	M 180×3	16	2,70	AH 24034	KM 36	HMV 36 E	
	170	125	136	M 180×3	16	3,25	AH 24134	KM 36	HMV 36 E	
170	180	92	98	M 190×3	17	2,80	AH 3036	KM 38	HMV 38 E	
	180	105	110	M 190×3	17	3,40	AH 2236 G	KM 38	HMV 38 E	
	180	116	122	M 190×3	19	3,90	AH 3136 G	KM 38	HMV 38 E	
	180	140	146	M 190×3	24	4,85	AH 3236 G	KM 38	HMV 38 E	
	180	154	160	M 190×3	26	5,50	AH 2336 G	KM 38	HMV 38 E	
	180	116	127	M 190×3	16	3,20	AH 24036	KM 38	HMV 38 E	
180	180	134	145	M 190×3	16	3,75	AH 24136	KM 38	HMV 38 E	
	190	96	102	M 200×3	18	3,30	AH 3038 G	KM 40	HMV 40 E	
	190	112	117	M 200×3	18	3,90	AH 2238 G	KM 40	HMV 40 E	
	190	125	131	M 200×3	20	4,50	AH 3138 G	KM 40	HMV 40 E	
	190	145	152	M 200×3	25	5,40	AH 3238 G	KM 40	HMV 40 E	
	190	160	167	M 200×3	26	6,10	AH 2338 G	KM 40	HMV 40 E	
180	190	118	131	M 200×3	18	3,55	AH 24038	KM 40	HMV 40 E	
	190	146	159	M 200×3	18	4,45	AH 24138	KM 40	HMV 40 E	
	190	200	102	108	Tr 210×4	19	3,70	AH 3040 G	HM 42 T	HMV 42 E
		200	134	140	Tr 220×4	21	5,65	AH 3140	HM 3044	HMV 44 E
		200	153	160	Tr 220×4	25	6,60	AH 3240	HM 3044	HMV 44 E
		200	170	177	Tr 220×4	30	7,60	AH 2340	HM 3044	HMV 44 E
200	127	140	Tr 210×4	18	4,00	AH 24040	HM 42 T	HMV 42 E		
200	158	171	Tr 210×4	18	5,05	AH 24140	HM 42 T	HMV 42 E		

¹⁾Width before the sleeve is driven into the bearing bore

Dimensions								Mass	Designations	Appropriate nut for dismounting	hydraulic nut	
d ₁	d	B ₁	B ₂ ¹⁾	G	G ₁	G ₂	A		Withdrawal sleeve			
mm								kg	–			
200	220	111	117	Tr 230x4	20	G 1/8	6,5	7,30	AOH 3044 G	HM 46 T	HMV 46 E	
	220	145	151	Tr 240x4	23	G 1/4	9	9,30	AOH 3144	HM 3048	HMV 48 E	
	220	181	189	Tr 240x4	30	G 1/4	9	13,5	AOH 2344	HM 3048	HMV 48 E	
	220	138	152	Tr 230x4	20	G 1/8	6,5	7,45	AOH 24044	HM 46 T	HMV 46 E	
	220	170	184	Tr 230x4	20	G 1/8	6,5	10,0	AOH 24144	HM 46 T	HMV 46 E	
	220	116	123	Tr 260x4	21	G 1/4	9	7,95	AOH 3048	HM 3052	HMV 52 E	
220	240	154	161	Tr 260x4	25	G 1/4	9	12,0	AOH 3148	HM 3052	HMV 52 E	
	240	189	197	Tr 260x4	30	G 1/4	9	14,0	AOH 2348	HM 3052	HMV 52 E	
	240	138	153	Tr 250x4	20	G 1/8	6,5	8,05	AOH 24048	HM 50 T	HMV 50 E	
	240	180	195	Tr 260x4	20	G 1/4	9	11,5	AOH 24148	HM 3052	HMV 52 E	
	240	128	135	Tr 280x4	23	G 1/4	9	9,60	AOH 3052	HM 3056	HMV 56 E	
	240	155	161	Tr 280x4	23	G 1/4	9	13,5	AOH 2252 G	HM 3056	HMV 56 E	
240	260	172	179	Tr 280x4	26	G 1/4	9	15,5	AOH 3152 G	HM 3056	HMV 56 E	
	260	205	213	Tr 280x4	30	G 1/4	9	19,0	AOH 2352 G	HM 3056	HMV 56 E	
	260	162	178	Tr 280x4	22	G 1/8	6,5	12,5	AOH 24052 G	HM 3056	HMV 56 E	
	260	202	218	Tr 280x4	22	G 1/4	9	14,0	AOH 24152	HM 3056	HMV 56 E	
	260	131	139	Tr 300x4	24	G 1/4	9	11,0	AOH 3056	HM 3060	HMV 60 E	
	260	155	163	Tr 300x4	24	G 1/4	9	15,0	AOH 2256 G	HM 3160	HMV 60 E	
260	280	175	183	Tr 300x4	28	G 1/4	9	17,0	AOH 3156 G	HM 3160	HMV 60 E	
	280	212	220	Tr 300x4	30	G 1/4	9	21,5	AOH 2356 G	HM 3160	HMV 60 E	
	280	162	179	Tr 300x4	22	G 1/8	6,5	13,5	AOH 24056 G	HM 3160	HMV 60 E	
	280	202	219	Tr 300x4	22	G 1/4	9	15,0	AOH 24156	HM 3160	HMV 60 E	
	280	145	153	Tr 320x5	26	G 1/4	9	13,0	AOH 3060	HM 3064	HMV 64 E	
	280	170	178	Tr 320x5	26	G 1/4	9	18,0	AOH 2260 G	HM 3164	HMV 64 E	
280	300	192	200	Tr 320x5	30	G 1/4	9	20,5	AOH 3160 G	HM 3164	HMV 64 E	
	300	228	236	Tr 320x5	34	G 1/4	9	23,5	AOH 2360 G	HM 3164	HMV 64 E	
	300	184	202	Tr 320x5	24	G 1/8	6,5	17,0	AOH 24060 G	HM 3164	HMV 64 E	
	300	224	242	Tr 320x5	24	G 1/4	9	18,5	AOH 24160	HM 3164	HMV 64 E	

¹⁾Width before the sleeve is driven into the bearing bore

Withdrawal sleeves d₁ 300 – 500 mm

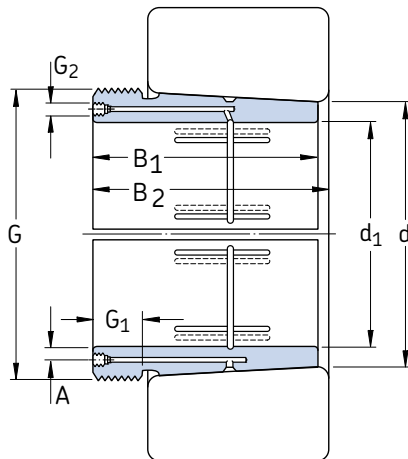

Dimensions								Mass	Designations Withdrawal sleeve	Appropriate nut for dismounting	hydraulic nut
d ₁	d	B ₁	B ₂ ¹⁾	G	G ₁	G ₂	A				
mm								kg	–		
300	320	149	157	Tr 340x5	27	G 1/4	9	16,5	AOH 3064 G	HM 3068	HMV 68 E
	320	180	190	Tr 340x5	27	G 1/4	9	20,0	AOH 2264 G	HM 3168	HMV 68 E
	320	209	217	Tr 340x5	31	G 1/4	9	24,5	AOH 3164 G	HM 3168	HMV 68 E
	320	246	254	Tr 340x5	36	G 1/4	9	27,5	AOH 3264 G	HM 3168	HMV 68 E
	320	184	202	Tr 340x5	24	G 1/8	6,5	18,0	AOH 24064 G	HM 3168	HMV 68 E
	320	242	260	Tr 340x5	24	G 1/4	9	20,5	AOH 24164	HM 3168	HMV 68 E
320	340	162	171	Tr 360x5	28	G 1/4	9	19,0	AOH 3068 G	HM 3072	HMV 72 E
	340	225	234	Tr 360x5	33	G 1/4	9	28,5	AOH 3168 G	HM 3172	HMV 72 E
	340	264	273	Tr 360x5	38	G 1/4	9	32,0	AOH 3268 G	HM 3172	HMV 72 E
	340	206	225	Tr 360x5	26	G 1/4	9	18,0	AOH 24068	HM 3172	HMV 72 E
	340	269	288	Tr 360x5	26	G 1/4	9	25,5	AOH 24168	HM 3172	HMV 72 E
	340	360	167	176	Tr 380x5	30	G 1/4	9	21,0	AOH 3072 G	HM 3076
360		229	238	Tr 380x5	35	G 1/4	9	30,5	AOH 3172 G	HM 3176	HMV 76 E
360		274	283	Tr 380x5	40	G 1/4	9	35,5	AOH 3272 G	HM 3176	HMV 76 E
360		206	226	Tr 380x5	26	G 1/4	9	20,0	AOH 24072	HM 3176	HMV 76 E
360		269	289	Tr 380x5	26	G 1/4	9	26,0	AOH 24172	HM 3176	HMV 76 E
360		380	170	180	Tr 400x5	31	G 1/4	9	22,5	AOH 3076 G	HM 3080
	380	232	242	Tr 400x5	36	G 1/4	9	33,0	AOH 3176 G	HM 3180	HMV 80 E
	380	284	294	Tr 400x5	42	G 1/4	9	42,0	AOH 3276 G	HM 3180	HMV 80 E
	380	208	228	Tr 400x5	28	G 1/4	9	23,5	AOH 24076	HM 3180	HMV 80 E
	380	271	291	Tr 400x5	28	G 1/4	9	31,0	AOH 24176	HM 3180	HMV 80 E
	380	400	183	193	Tr 420x5	33	G 1/4	9	26,0	AOH 3080 G	HM 3080
400		240	250	Tr 420x5	38	G 1/4	9	36,0	AOH 3180 G	HM 3184	HMV 84 E
400		302	312	Tr 420x5	44	G 1/4	9	48,0	AOH 3280 G	HM 3184	HMV 84 E
400		228	248	Tr 420x5	28	G 1/4	9	27,0	AOH 24080	HM 3184	HMV 84 E
400		278	298	Tr 420x5	28	G 1/4	9	35,0	AOH 24180	HM 3184	HMV 84 E

¹⁾ Width before the sleeve is driven into the bearing bore

Dimensions								Mass	Designations	Appropriate nut for dismounting	hydraulic nut	
d ₁	d	B ₁	B ₂ ¹⁾	G	G ₁	G ₂	A		Withdrawal sleeve			
mm								kg	–			
400	420	186	196	Tr 440x5	34	G 1/4	9	28,0	AOH 3084 G	HM 3088	HMV 88 E	
	420	266	276	Tr 440x5	40	G 1/4	9	43,0	AOH 3184 G	HM 3188	HMV 88 E	
	420	321	331	Tr 440x5	46	G 1/4	9	54,5	AOH 3284 G	HM 3188	HMV 88 E	
	420	230	252	Tr 440x5	30	G 1/4	9	29,0	AOH 24084	HM 3188	HMV 88 E	
	420	310	332	Tr 440x5	30	G 1/4	9	39,0	AOH 24184	HM 3188	HMV 88 E	
	420	440	194	205	Tr 460x5	35	G 1/4	9	31,0	AOHX 3088 G	HM 3092	HMV 92 E
	440	270	281	Tr 460x5	42	G 1/4	9	46,0	AOHX 3188 G	HM 3192	HMV 92 E	
	440	330	341	Tr 460x5	48	G 1/4	9	64,5	AOHX 3288 G	HM 3192	HMV 92 E	
	440	242	264	Tr 460x5	30	G 1/4	9	32,0	AOH 24088	HM 3192	HMV 92 E	
	440	310	332	Tr 460x5	30	G 1/4	9	45,5	AOH 24188	HM 3192	HMV 92 E	
440	460	202	213	Tr 480x5	37	G 1/4	9	34,0	AOHX 3092 G	HM 3096	HMV 96 E	
	460	285	296	Tr 480x5	43	G 1/4	9	51,5	AOHX 3192 G	HM 3196	HMV 96 E	
	460	349	360	Tr 480x5	50	G 1/4	9	80,0	AOHX 3292 G	HM 3196	HMV 96 E	
	460	250	273	Tr 480x5	32	G 1/4	9	34,5	AOH 24092	HM 3196	HMV 96 E	
	460	332	355	Tr 480x5	32	G 1/4	9	50,0	AOH 24192	HM 3196	HMV 96 E	
460	480	205	217	Tr 500x5	38	G 1/4	9	34,0	AOHX 3096 G	HM 30/500	HMV 100 E	
	480	295	307	Tr 500x5	45	G 1/4	9	63,0	AOHX 3196 G	HM 31/500	HMV 100 E	
	480	364	376	Tr 500x5	52	G 1/4	9	81,0	AOHX 3296 G	HM 31/500	HMV 100 E	
	480	250	273	Tr 500x5	32	G 1/4	9	36,5	AOH 24096	HM 31/500	HMV 100 E	
	480	340	363	Tr 500x5	32	G 1/4	9	51,5	AOH 24196	HM 31/500	HMV 100 E	
	480	500	209	221	Tr 530x6	40	G 1/4	9	41,0	AOHX 30/500 G	HM 30/530	HMV 106 E
	500	313	325	Tr 530x6	47	G 1/4	9	66,5	AOHX 31/500 G	HM 31/530	HMV 106 E	
	500	393	405	Tr 530x6	54	G 1/4	9	89,5	AOHX 32/500 G	HM 31/530	HMV 106 E	
	500	253	276	Tr 530x6	35	G 1/4	9	43,0	AOH 240/500	HM 31/530	HMV 106 E	
	500	360	383	Tr 530x6	35	G 1/4	9	63,0	AOH 241/500	HM 31/530	HMV 106 E	
500	530	230	242	Tr 560x6	45	G 1/4	10	63,5	AOH 30/530	HM 30/560	HMV 112 E	
	530	325	337	Tr 560x6	53	G 1/4	10	93,5	AOH 31/530	HM 31/560	HMV 112 E	
	530	412	424	Tr 560x6	57	G 1/4	10	142	AOH 32/530 G	HM 31/560	HMV 112 E	
	530	285	309	Tr 560x6	35	G 1/4	9	64,5	AOH 240/530 G	HM 31/560	HMV 112 E	
	530	370	394	Tr 560x6	35	G 1/4	9	92,0	AOH 241/530 G	HM 31/560	HMV 112 E	

¹⁾ Width before the sleeve is driven into the bearing bore

Withdrawal sleeves

d_1 530 – 1 000 mm

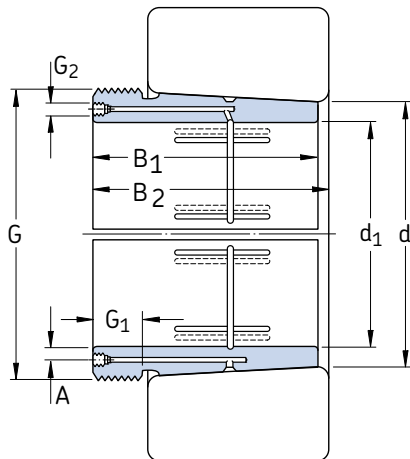

Dimensions								Mass	Designations Withdrawal sleeve	Appropriate nut for dismounting	hydraulic nut
d_1	d	B_1	$B_2^{1)}$	G	G_1	G_2	A				
mm								kg	–		
530	560	240	252	Tr 600×6	45	G 1/4	11	73,5	A0HX 30/560	HM 30/600	HMV 120 E
	560	335	347	Tr 600×6	55	G 1/4	11	107	A0H 31/560	HM 31/600	HMV 120 E
	560	422	434	Tr 600×6	57	G 1/4	11	143	A0HX 32/560	HM 31/600	HMV 120 E
	560	296	320	Tr 600×6	38	G 1/4	9	71,0	A0H 240/560 G	HM 31/600	HMV 120 E
	560	393	417	Tr 600×6	38	G 1/4	9	107	A0H 241/560 G	HM 31/600	HMV 120 E
	570	600	245	259	Tr 630×6	45	G 1/4	11	77,0	A0HX 30/600	HM 30/630
	600	355	369	Tr 630×6	55	G 1/4	11	120	A0HX 31/600	HM 31/630	HMV 126 E
	600	445	459	Tr 630×6	57	G 1/4	11	159	A0HX 32/600 G	HM 31/630	HMV 126 E
	600	310	336	Tr 630×6	38	G 1/4	9	108	A0HX 240/600	HM 31/630	HMV 126 E
	600	413	439	Tr 630×6	38	G 1/4	9	120	A0HX 241/600	HM 31/630	HMV 126 E
600	630	258	272	Tr 670×6	46	G 1/4	11	88,5	A0H 30/630	HM 30/670	HMV 134 E
	630	375	389	Tr 670×6	60	G 1/4	11	139	A0H 31/630	HM 31/670	HMV 134 E
	630	475	489	Tr 670×6	63	G 1/4	11	188	A0H 32/630 G	HM 31/670	HMV 134 E
	630	330	356	Tr 670×6	40	G 1/4	9	101	A0H 240/630 G	HM 31/670	HMV 134 E
	630	440	466	Tr 670×6	40	G 1/4	9	139	A0H 241/630 G	HM 31/670	HMV 134 E
	630	670	280	294	Tr 710×7	50	G 1/4	12	125	A0H 30/670	HM 30/710
670		395	409	Tr 710×7	59	G 1/4	12	189	A0HX 31/670	HM 31/710	HMV 142 E
670		500	514	Tr 710×7	62	G 1/4	12	252	A0H 32/670 G	HM 31/710	HMV 142 E
670		348	374	Tr 710×7	40	G 1/4	12	140	A0H 240/670 G	HM 31/710	HMV 142 E
670		452	478	Tr 710×7	40	G 1/4	12	180	A0H 241/670	HM 31/710	HMV 142 E
670		710	286	302	Tr 750×7	50	G 1/4	15	138	A0HX 30/710	HM 30/750
	710	405	421	Tr 750×7	60	G 1/4	15	207	A0HX 31/710	HM 31/750	HMV 150 E
	710	515	531	Tr 750×7	65	G 1/4	15	278	A0H 32/710 G	HM 31/750	HMV 150 E
	710	360	386	Tr 750×7	45	G 1/4	12	155	A0H 240/710 G	HM 31/750	HMV 150 E
	710	483	509	Tr 750×7	45	G 1/4	12	205	A0H 241/710	HM 31/750	HMV 150 E
	710	750	300	316	Tr 800×7	50	G 1/4	15	145	A0H 30/750	HM 30/800
750		425	441	Tr 800×7	60	G 1/4	15	238	A0H 31/750	HM 31/800	HMV 160 E
750		540	556	Tr 800×7	65	G 1/4	15	320	A0H 32/750	HM 31/800	HMV 160 E
750		380	408	Tr 800×7	45	G 1/4	12	178	A0H 240/750 G	HM 31/800	HMV 160 E
750		520	548	Tr 800×7	45	G 1/4	12	240	A0H 241/750 G	HM 31/800	HMV 160 E

¹⁾ Width before the sleeve is driven into the bearing bore

Dimensions								Mass	Designations	Appropriate nut for dismounting	hydraulic nut	
d ₁	d	B ₁	B ₂ ¹⁾	G	G ₁	G ₂	A		Withdrawal sleeve			
mm								kg	–			
750	800	308	326	Tr 850×7	50	G 1/4	15	204	AOH 30/800	HM 30/850	HMV 170 E	
	800	438	456	Tr 850×7	63	G 1/4	15	305	AOH 31/800	HM 31/850	HMV 170 E	
	800	550	568	Tr 850×7	67	G 1/4	15	401	AOH 32/800	HM 31/850	HMV 170 E	
	800	395	423	Tr 850×7	50	G 1/4	15	237	AOH 240/800 G	HM 31/850	HMV 170 E	
	800	525	553	Tr 850×7	50	G 1/4	15	318	AOH 241/800 G	HM 31/850	HMV 170 E	
	800	850	325	343	Tr 900×7	53	G 1/4	15	230	AOH 30/850	HM 30/900	HMV 180 E
850		462	480	Tr 900×7	62	G 1/4	15	345	AOH 31/850	HM 31/900	HMV 180 E	
850		585	603	Tr 900×7	70	G 1/4	15	461	AOH 32/850	HM 31/900	HMV 180 E	
850		415	445	Tr 900×7	50	G 1/4	15	265	AOH 240/850 G	HM 31/900	HMV 180 E	
850		560	600	Tr 900×7	60	G 1/4	15	368	AOH 241/850	HM 31/900	HMV 180 E	
850		900	335	355	Tr 950×8	55	G 1/4	15	250	AOH 30/900	HM 30/950	HMV 190 E
	900	475	495	Tr 950×8	63	G 1/4	15	379	AOH 31/900	HM 31/950	HMV 190 E	
	900	585	605	Tr 950×8	70	G 1/4	15	489	AOH 32/900	HM 31/950	HMV 190 E	
	900	430	475	Tr 950×8	55	G 1/4	15	296	AOH 240/900	HM 31/950	HMV 190 E	
	900	575	620	Tr 950×8	60	G 1/4	15	402	AOH 241/900	HM 31/950	HMV 190 E	
	900	950	355	375	Tr 1000×8	55	G 1/4	15	285	AOH 30/950	HM 30/1000	HMV 200 E
950		500	520	Tr 1000×8	62	G 1/4	15	426	AOH 31/950	HM 31/1000	HMV 200 E	
950		600	620	Tr 1000×8	70	G 1/4	15	533	AOH 32/950	HM 31/1000	HMV 200 E	
950		467	512	Tr 1000×8	55	G 1/4	15	340	AOH 240/950	HM 31/1000	HMV 200 E	
950		605	650	Tr 1000×8	60	G 1/4	15	449	AOH 241/950	HM 31/1000	HMV 200 E	
950		1 000	365	387	Tr 1060×8	57	G 1/4	15	318	AOH 30/1000	HM 30/1060	HMV 212 E
	1 000	525	547	Tr 1060×8	63	G 1/4	15	485	AOH 31/1000	HM 31/1060	HMV 212 E	
	1 000	630	652	Tr 1060×8	70	G 1/4	15	608	AOH 32/1000	HM 31/1060	HMV 212 E	
	1 000	469	519	Tr 1060×8	57	G 1/4	15	369	AOH 240/1000	HM 31/1060	HMV 212 E	
	1 000	645	695	Tr 1060×8	65	G 1/4	15	519	AOH 241/1000	HM 31/1060	HMV 212 E	
	1 000	1 060	385	407	Tr 1120×8	60	G 1/4	15	406	AOH 30/1060	HM 30/1120	HMV 224 E
1 060		540	562	Tr 1120×8	65	G 1/4	15	599	AOH 31/1060	HM 30/1120	HMV 224 E	
1 060		498	548	Tr 1120×8	60	G 1/4	15	479	AOH 240/1060	HM 30/1120	HMV 224 E	
1 060		665	715	Tr 1120×8	65	G 1/4	15	652	AOH 241/1060	HM 30/1120	HMV 224 E	

¹⁾ Width before the sleeve is driven into the bearing bore

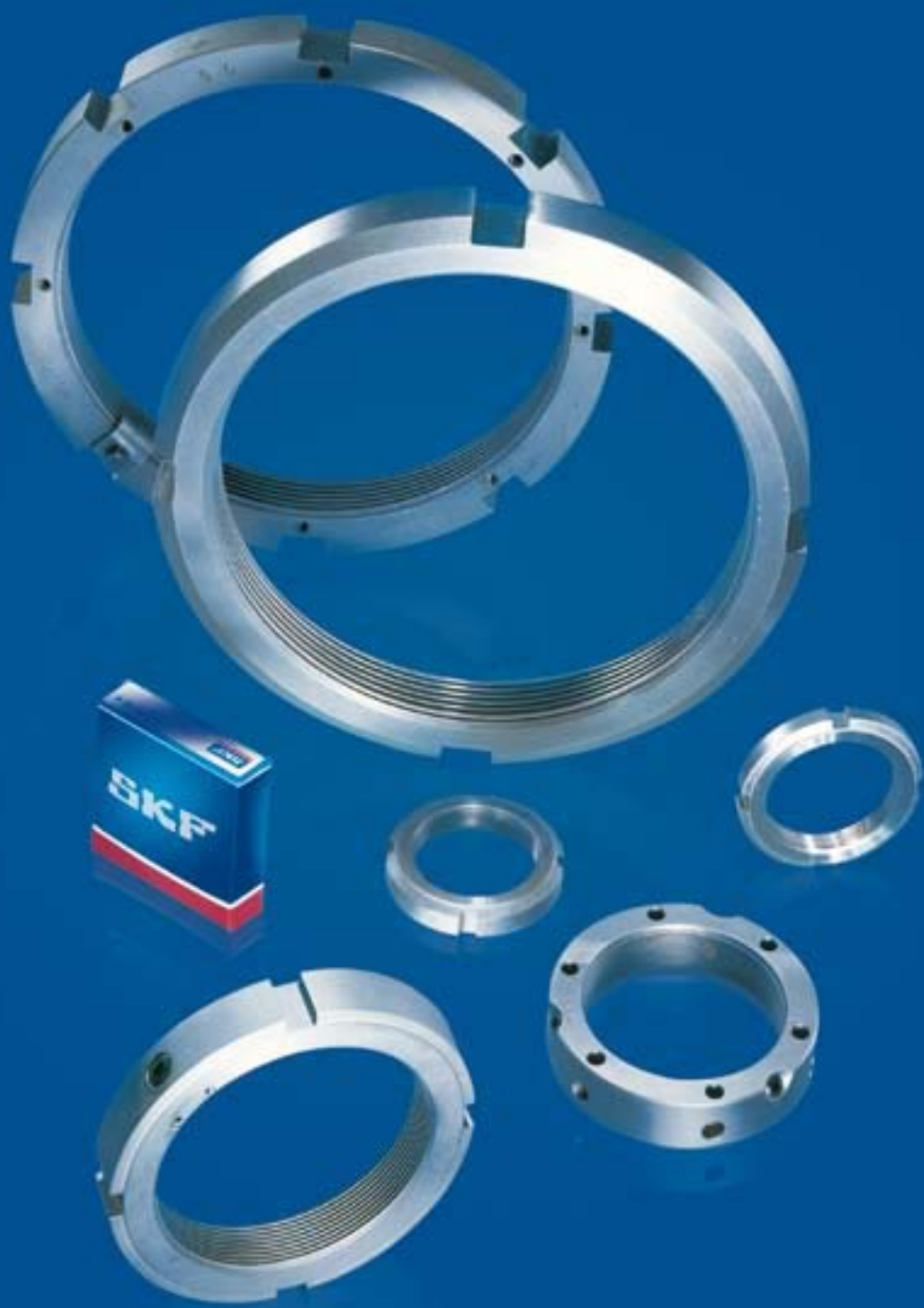

Lock nuts

Lock nuts with locking washer or clip	1010
Lock nuts with integral locking device	1020
Lock nuts with locking screw	1022
Precision lock nuts with locking pins	1024
Product tables	1012
KM(L) lock nuts with locking washer	1012
HM(E) lock nuts with locking clip	1014
MB(L) locking washers	1016
MS locking clips	1018
KMK lock nuts with integral locking device.....	1021
KMFE lock nuts with locking screw.....	1023
KMT precision lock nuts with locking pins	1026
KMTA precision lock nuts with locking pins	1028

Lock nuts

SKF supplies lock nuts in a wide range of sizes; they are also referred to as shaft or withdrawal nuts, depending on their use. They are used to locate bearings and other components onto a shaft as well as to facilitate mounting bearings on tapered journals and dismounting bearings from withdrawal sleeves. SKF lock nuts offer five different ways of locking on the shaft, as described below.

Locking washer

Locking washers are simple, stable and reliable fastening elements. The washer engages a keyway in the shaft and locks the nut in position if one of the tabs is bent over into one of the slots around the circumference of the nut. Locking washers are used with lock nuts in the KM and KML series (→ **fig. 1**).

Locking clip

Locking clips are attached to the nut using a bolt to engage a slot in the nut and a keyway in the shaft. This locking device is used with lock nuts in the HM 30 and 31 series (→ **fig. 2**).

Locking screw

A small part of the nut thread is pressed into the shaft thread by a locking screw to prevent the nut from turning. Neither additional locking washer nor a keyway in the shaft is required. Lock nuts with locking screw (→ **fig. 3**) are designated KMFE.

Fig. 1

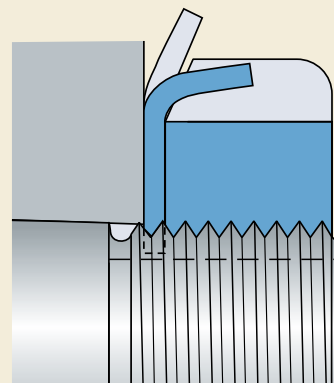

Fig. 2

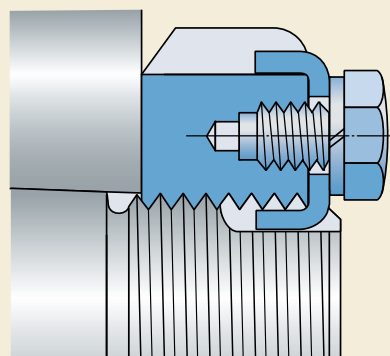
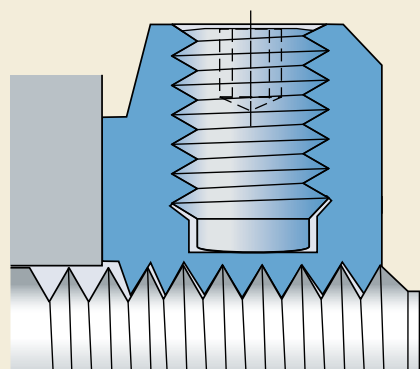

Fig. 3



Locking device

A steel insert, an integral part of the nut thread, can be pressed against the shaft thread by a grub screw to prevent the nut from turning. Neither additional locking washer nor keyway in the shaft is required. Lock nuts with this kind of locking device (→ **fig. 4**) are designated KMK.

Locking pins

Three locking pins are equally spaced around the circumference of the nut. The pins are arranged at the same angle as the thread flanks and can be pressed into the shaft thread by grub screws. The pins not only lock the nut but also accurately locate it at right angles to the shaft. No keyway in the shaft is required. Locking pins are used with the precision lock nuts in the KMT and KMTA series (→ **fig. 5**).

Fig. 4

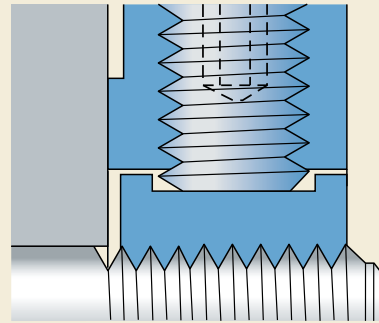
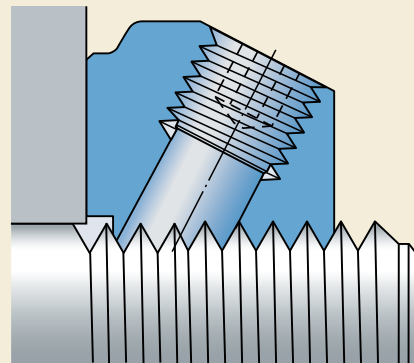

Fig. 5



Lock nuts with locking washer or clip

SKF lock nuts with a locking washer or clip have four or eight equally spaced slots respectively, around the outside diameter (→ **fig.6**) to take a hook or impact spanner. The designations of the appropriate spanners are provided in the product tables.

The nut and the locking device must be ordered separately. The appropriate locking washer or clip is shown in the product tables.

Besides metric lock nuts shown in this catalogue, inch lock nuts with an American National Form NS Class 3 or an ACME Class 3G General Purpose thread can be supplied too. Details are contained in the SKF catalogue “Bearing accessories” or in the “SKF Interactive Engineering Catalogue” on CD-ROM or online at www.skf.com.

KM(L) lock nuts with locking washer

Lock nuts in the KM and KML series are available for metric ISO threads up to and including 200 mm and are locked with an MB(L) washer (→ **fig. 7**) or with the stronger MB .. A design.

HM(E) lock nuts with locking clip

Lock nuts in the HM(E) 30 and HM 31 series with metric trapezoidal threads are locked by an MS locking clip consisting of the clip, a hexagon headed bolt to EN ISO 4017:2000 and a spring locking washer to DIN 128 (→ **fig. 8**).

Fig. 6

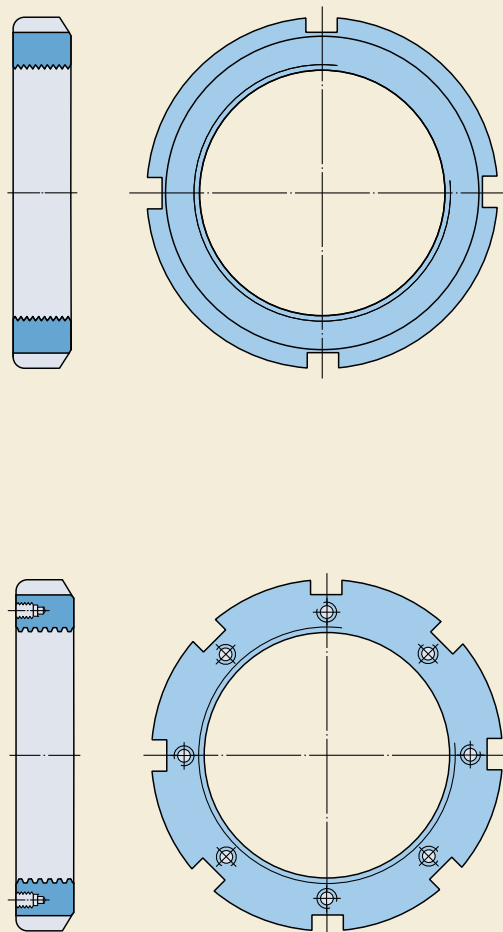
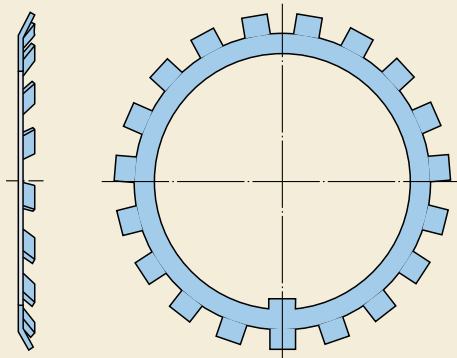

Fig. 7



Dimensions

The dimensions and the thread of the nuts are in accordance with ISO 2982-2:2001. The dimensions of the locking washers and locking clips also follow this standard.

Tolerances

The metric ISO thread of KM and KML lock nuts is machined to tolerance 5H according to ISO 965-3:1998, and the metric trapezoidal thread of HM lock nuts to tolerance 7H, ISO 2903:1993.

The maximum runout between the thread and the locating face is between 0,04 and 0,06 mm depending on the size of the lock nut.

Fig. 8

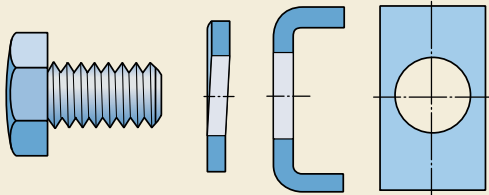

Materials

SKF lock nuts up to and including size HM 3160 and HM 3064 respectively are made of spheroidal graphite cast iron. The larger nuts are made of steel. SKF lock nuts are protected by a solventless rust inhibitor. The locking washers and locking clips are made of deep drawn steel strip.

Mating shaft threads

SKF recommends that the mating thread on the shaft be made to 6g according to ISO 965-3:1998 for the smaller nuts and to tolerance 7e according to ISO 2903:1993 for those with a trapezoidal thread.

KM(L) lock nuts with locking washer
M 10×0,75 – M 200×3

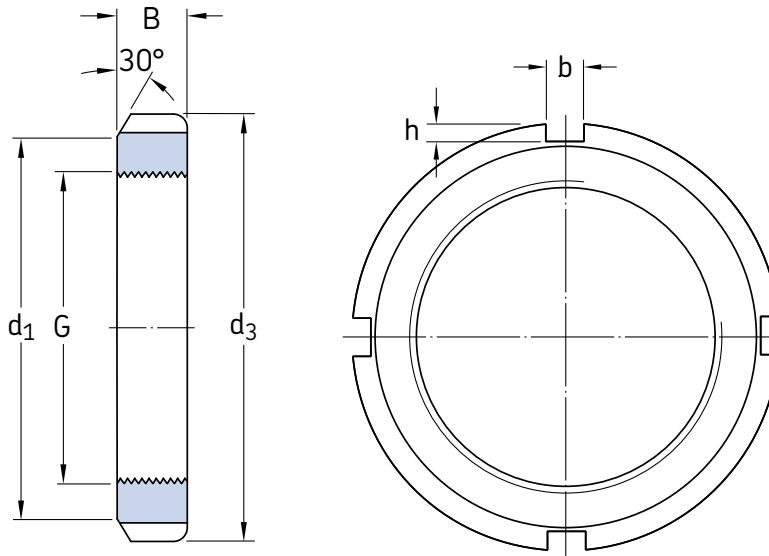

Dimensions						Axial load carrying capacity static	Mass	Designations		
G	d ₁	d ₃	B	b	h			Lock nut	Appropriate locking washer	spanner
mm						kN	kg	–		
M 10×0,75	13,5	18	4	3	2	9,8	0,004	KM 0	MB 0	–
M 12×1	17	22	4	3	2	11,8	0,006	KM 1	MB 1	HN 1
M 15×1	21	25	5	4	2	14,6	0,009	KM 2	MB 2	HN 2
M 17×1	24	28	5	4	2	19,6	0,012	KM 3	MB 3	HN 3
M 20×1	26	32	6	4	2	24	0,025	KM 4	MB 4	HN 4
M 25×1,5	32	38	7	5	2	31,5	0,028	KM 5	MB 5	HN 5
M 30×1,5	38	45	7	5	2	36,5	0,039	KM 6	MB 6	HN 6
M 35×1,5	44	52	8	5	2	50	0,059	KM 7	MB 7	HN 7
M 40×1,5	50	58	9	6	2,5	62	0,078	KM 8	MB 8	HN 8
M 45×1,5	56	65	10	6	2,5	78	0,11	KM 9	MB 9	HN 9
M 50×1,5	61	70	11	6	2,5	91,5	0,14	KM 10	MB 10	HN 10
M 55×2	67	75	11	7	3	91,5	0,15	KM 11	MB 11	HN 11
M 60×2	73	80	11	7	3	95	0,16	KM 12	MB 12	HN 12
M 65×2	79	85	12	7	3	108	0,19	KM 13	MB 13	HN 13
M 70×2	85	92	12	8	3,5	118	0,23	KM 14	MB 14	HN 14
M 75×2	90	98	13	8	3,5	134	0,27	KM 15	MB 15	HN 15
M 80×2	95	105	15	8	3,5	173	0,36	KM 16	MB 16	HN 16
M 85×2	102	110	16	8	3,5	190	0,41	KM 17	MB 17	HN 17
M 90×2	108	120	16	10	4	216	0,51	KM 18	MB 18	HN 18
M 95×2	113	125	17	10	4	236	0,55	KM 19	MB 19	HN 19
M 100×2	120	130	18	10	4	255	0,64	KM 20	MB 20	HN 20

Dimensions						Axial load carrying capacity static	Mass	Designations		
G	d ₁	d ₃	B	b	h			Lock nut	Appropriate locking washer	spanner
mm						kN	kg	–		
M 105×2	126	140	18	12	5	290	0,79	KM 21	MB 21	HN 21
M 110×2	133	145	19	12	5	310	0,87	KM 22	MB 22	HN 22
M 115×2	137	150	19	12	5	315	0,91	KM 23	MB 23	TMFN 23-30
M 120×2	135	145	20	12	5	265	0,69	KML 24 KM 24	MBL 24	TMFN 23-30
	138	155	20	12	5	340	0,97		MB 24	TMFN 23-30
M 125×2	148	160	21	12	5	360	1,09	KM 25	MB 25	TMFN 23-30
M 130×2	145	155	21	12	5	285	0,80	KML 26 KM 26	MBL 26	TMFN 23-30
	149	165	21	12	5	365	1,09		MB 26	TMFN 23-30
M 135×2	160	175	22	14	6	430	1,39	KM 27	MB 27	TMFN 23-30
M 140×2	155	165	22	12	5	305	0,92	KML 28 KM 28	MBL 28	TMFN 23-30
	160	180	22	14	6	430	1,40		MB 28	TMFN 23-30
M 145×2	171	190	24	14	6	520	1,80	KM 29	MB 29	TMFN 23-30
M 150×2	170	180	24	14	5	390	1,25	KML 30 KM 30	MBL 30	TMFN 23-30
	171	195	24	14	6	530	1,88		MB 30	TMFN 23-30
M 155×3	182	200	25	16	7	540	2,09	KM 31	MB 31	TMFN 30-40
M 160×3	180	190	25	14	5	405	1,39	KML 32 KM 32	MBL 32	TMFN 23-30
	182	210	25	16	7	585	2,29		MB 32	TMFN 30-40
M 165×3	193	210	26	16	7	570	2,31	KM 33	MB 33	TMFN 30-40
M 170×3	190	200	26	16	5	430	1,56	KML 34 KM 34	MBL 34	TMFN 30-40
	193	220	26	16	7	620	2,34		MB 34	TMFN 30-40
M 180×3	200	210	27	16	5	450	1,78	KML 36 KM 36	MBL 36	TMFN 30-40
	203	230	27	18	8	670	2,78		MB 36	TMFN 30-40
M 190×3	210	220	28	16	5	475	1,84	KML 38 KM 38	MBL 38	TMFN 30-40
	214	240	28	18	8	695	3,05		MB 38	TMFN 30-40
M 200×3	222	240	29	18	8	625	2,61	KML 40 KM 40	MBL 40	TMFN 30-40
	226	250	29	18	8	735	3,37		MB 40	TMFN 30-40

HM(E) lock nuts with locking clip
Tr 220×4 – Tr 950×8

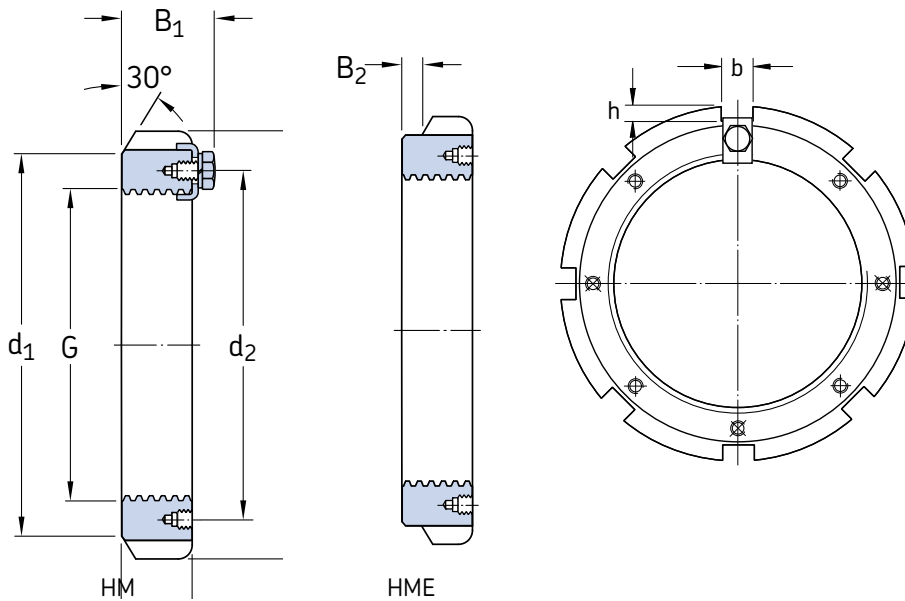

Dimensions									Mass	Designations		
G	d ₁	d ₂	d ₃	B	B ₁	B ₂	b	h		Lock nut without locking clip	Appropriate locking clip	spanner
mm									kg	–		
Tr 220×4	242	229	260	30	41	–	20	9	2,75	HM 3044	MS 3044	TMFN 40-52
Tr 240×4	270	253	290	34	46	–	20	10	4,50	HM 3048	MS 3052-48	TMFN 40-52
	270	253	290	34	46	5	20	10	4,50	HME 3048	MS 3052-48	TMFN 40-52
Tr 260×4	290	273	310	34	46	–	20	10	4,80	HM 3052	MS 3052-48	TMFN 40-52
Tr 280×4	310	293	330	38	50	–	24	10	5,75	HM 3056	MS 3056	TMFN 52-64
Tr 300×4	336	316	360	42	54	–	24	12	8,35	HM 3060	MS 3060	TMFN 52-64
	340	326	380	40	53	–	24	12	11,5	HM 3160	MS 3160	TMFN 52-64
Tr 320×5	356	336	380	42	55	–	24	12	9,00	HM 3064	MS 3068-64	TMFN 52-64
	360	346	400	42	56	–	24	12	13,0	HM 3164	MS 3164	TMFN 52-64
Tr 340×5	376	356	400	45	58	–	24	12	11,0	HM 3068	MS 3068-64	TMFN 52-64
	400	373	440	55	72	–	28	15	24,0	HM 3168	MS 3172-68	TMFN 64-80
Tr 360×5	394	375	420	45	58	–	28	13	11,5	HM 3072	MS 3072	TMFN 64-80
	420	393	460	58	75	–	28	15	26,5	HM 3172	MS 3172-68	TMFN 64-80
Tr 380×5	422	399	450	48	62	–	28	14	15,0	HM 3076	MS 3080-76	TMFN 64-80
	440	415	490	60	77	–	32	18	32,0	HM 3176	MS 3176	TMFN 64-80
Tr 400×5	442	419	470	52	66	–	28	14	17,0	HM 3080	MS 3080-76	TMFN 64-80
	460	440	520	62	82	–	32	18	38,0	HM 3180	MS 3184-80	TMFN 64-80
Tr 420×5	462	439	490	52	66	–	32	14	18,5	HM 3084	MS 3084	TMFN 64-80
	462	439	490	52	66	5	32	14	18,5	HME 3084	MS 3084	TMFN 64-80
	490	460	540	70	90	–	32	18	45,0	HM 3184	MS 3184-80	TMFN 80-500
Tr 440×5	490	463	520	60	77	–	32	15	26,0	HM 3088	MS 3092-88	TMFN 64-80
	510	478	560	70	90	–	36	20	46,5	HM 3188	MS 3192-88	TMFN 80-500
Tr 460×5	510	483	540	60	77	–	32	15	27,0	HM 3092	MS 3092-88	TMFN 80-500
	540	498	580	75	95	–	36	20	50,5	HM 3192	MS 3192-88	TMFN 80-500
Tr 480×5	530	503	560	60	77	–	36	15	28,0	HM 3096	MS 30/500-96	TMFN 80-500
	560	528	620	75	95	–	36	20	62,0	HM 3196	MS 3196	TMFN 80-500

For HME lock nuts not listed in the table, please contact SKF

Dimensions									Mass	Designations Lock nut without locking clip	Appropriate locking clip	spanner
G	d ₁	d ₂	d ₃	B	B ₁	B ₂	b	h				
mm									kg	–		
Tr 500×5	550	523	580	68	85	–	36	15	33,5	HM 30/500	MS 30/500-96	TMFN 80-500
	550	523	580	68	85	8	36	15	33,5	HME 30/500	MS 30/500-96	TMFN 80-500
	580	540	630	80	100	–	40	23	63,5	HM 31/500	MS 31/500	TMFN 80-500
Tr 530×6	590	558	630	68	90	–	40	20	42,5	HM 30/530	MS 30/600-530	TMFN 500-600
	610	575	670	80	105	–	40	23	71,5	HM 31/530	MS 31/530	TMFN 500-600
Tr 560×6	610	583	650	75	97	–	40	20	44,5	HM 30/560	MS 30/560	TMFN 500-600
	610	583	650	75	97	12	40	20	44,5	HME 30/560	MS 30/560	TMFN 500-600
	650	608	710	85	110	–	45	25	86,5	HM 31/560	MS 31/600-560	TMFN 500-600
Tr 600×6	660	628	700	75	97	–	40	20	52,5	HM 30/600	MS 30/600-530	TMFN 500-600
	660	628	700	75	97	12	40	20	52,5	HME 30/600	MS 30/600-530	TMFN 500-600
	690	648	750	85	110	–	45	25	91,5	HM 31/600	MS 31/600-560	TMFN 500-600
Tr 630×6	690	658	730	75	97	–	45	20	55,0	HM 30/630	MS 30/630	TMFN 500-600
	730	685	800	95	120	–	50	28	125	HM 31/630	MS 31/630	TMFN 600-750
Tr 670×6	740	703	780	80	102	–	45	20	68,5	HM 30/670	MS 30/670	TMFN 600-750
	775	730	850	106	131	–	50	28	155	HM 31/670	MS 31/670	TMFN 600-750
Tr 710×7	780	742	830	90	112	–	50	25	91,5	HM 30/710	MS 30/710	TMFN 600-750
	780	742	830	90	112	12	50	25	91,5	HME 30/710	MS 30/710	TMFN 600-750
	825	772	900	106	133	–	55	30	162	HM 31/710	MS 31/710	TMFN 600-750
Tr 750×7	820	782	870	90	112	–	55	25	94,0	HM 30/750	MS 30/800-750	TMFN 600-750
	820	782	870	90	112	12	55	25	94,0	HME 30/750	MS 30/800-750	TMFN 600-750
	875	813	950	112	139	–	60	34	190	HM 31/750	MS 31/800-750	TMFN 600-750
Tr 800×7	870	832	920	90	112	–	55	25	99,5	HM 30/800	MS 30/800-750	TMFN 600-750
	925	863	1000	112	139	–	60	34	202	HM 31/800	MS 31/800-750	–
Tr 850×7	925	887	980	90	115	–	60	25	115	HM 30/850	MS 30/900-850	–
	925	887	980	90	115	12	60	25	110	HME 30/850	MS 30/900-850	–
	975	914	1060	118	145	–	70	38	234	HM 31/850	MS 31/850	–
Tr 900×7	975	937	1030	100	125	–	60	25	131	HM 30/900	MS 30/900-850	–
	1030	969	1120	125	154	–	70	38	280	HM 31/900	MS 31/900	–
Tr 950×8	1025	985	1080	100	125	–	60	25	139	HM 30/950	MS 30/950	–

For HME lock nuts not listed in the table, please contact SKF

MB(L) locking washers
d 10 – 200 mm

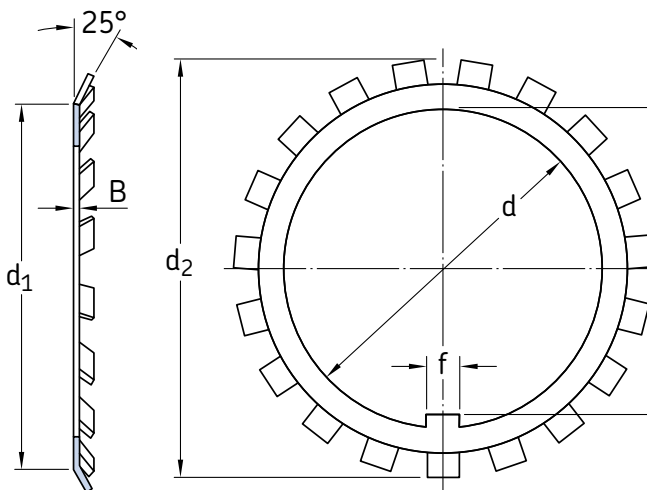

Dimensions						Mass	Designation	Dimensions						Mass	Designation
d	d ₁	d ₂	B	f	M			d	d ₁	d ₂	B	f	M		
mm						kg	–	mm						kg	–
10	13,5	21	1	3	8,5	0,001	MB 0	70	85	98	1,5	8	66,5	0,032	MB 14
									85	98	2,5	8	66,5	0,053	MB 14 A
12	17	25	1	3	10,5	0,002	MB 1	75	90	104	1,5	8	71,5	0,035	MB 15
	17	25	1,2	3	10,5	0,002	MB 1 A		90	104	2,5	8	71,5	0,058	MB 15 A
15	21	28	1	4	13,5	0,003	MB 2	80	95	112	1,75	10	76,5	0,046	MB 16
	21	28	1,2	4	13,5	0,003	MB 2 A		95	112	2,5	10	76,5	0,066	MB 16 A
17	24	32	1	4	15,5	0,003	MB 3	85	102	119	1,75	10	81,5	0,053	MB 17
	24	32	1,2	4	15,5	0,003	MB 3 A		102	119	2,5	10	81,5	0,076	MB 17 A
20	26	36	1	4	18,5	0,004	MB 4	90	108	126	1,75	10	86,5	0,061	MB 18
	26	36	1,2	4	18,5	0,005	MB 4 A		108	126	2,5	10	86,5	0,087	MB 18 A
25	32	42	1,25	5	23	0,006	MB 5	95	113	133	1,75	10	91,5	0,066	MB 19
	32	42	1,8	5	23	0,009	MB 5 A		113	133	2,5	10	91,5	0,094	MB 19 A
30	38	49	1,25	5	27,5	0,008	MB 6	100	120	142	1,75	12	96,5	0,077	MB 20
	38	49	1,8	5	27,5	0,011	MB 6 A		120	142	2,5	12	96,5	0,11	MB 20 A
35	44	57	1,25	6	32,5	0,011	MB 7	105	126	145	1,75	12	100,5	0,083	MB 21
	44	57	1,8	6	32,5	0,016	MB 7 A								
40	50	62	1,25	6	37,5	0,013	MB 8	110	133	154	1,75	12	105,5	0,091	MB 22
	50	62	1,8	6	37,5	0,018	MB 8 A								
45	56	69	1,25	6	42,5	0,015	MB 9	115	137	159	2	12	110,5	0,11	MB 23
	56	69	1,8	6	42,5	0,021	MB 9 A								
50	61	74	1,25	6	47,5	0,016	MB 10	120	135	152	2	14	115	0,07	MBL 24
	61	74	2,3	6	47,5	0,023	MB 10 A		138	164	2	14	115	0,11	MB 24
55	67	81	1,5	8	52,5	0,022	MB 11	125	148	170	2	14	120	0,12	MB 25
	67	81	2,5	8	52,5	0,037	MB 11 A								
60	73	86	1,5	8	57,5	0,024	MB 12	130	145	161	2	14	125	0,08	MBL 26
	73	86	2,5	8	57,5	0,040	MB 12 A		149	175	2	14	125	0,12	MB 26
65	79	92	1,5	8	62,5	0,030	MB 13	135	160	185	2	14	130	0,14	MB 27
	79	92	2,5	8	62,5	0,050	MB 13 A								
								140	155	172	2	16	135	0,09	MBL 28
									160	192	2	16	135	0,14	MB 28

Dimensions						Mass	Designation
d	d ₁	d ₂	B	f	M		
mm						kg	–
145	172	202	2	16	140	0,17	MB 29
150	170	189	2	16	145	0,10	MBL 30
	171	205	2	16	145	0,18	MB 30
155	182	212	2,5	16	147,5	0,20	MB 31
160	180	199	2,5	18	154	0,14	MBL 32
	182	217	2,5	18	154	0,22	MB 32
165	193	222	2,5	18	157,5	0,24	MB 33
170	190	211	2,5	18	164	0,15	MBL 34
	193	232	2,5	18	164	0,24	MB 34
180	200	222	2,5	20	174	0,16	MBL 36
	203	242	2,5	20	174	0,26	MB 36
190	210	232	2,5	20	184	0,17	MBL 38
	214	252	2,5	20	184	0,26	MB 38
200	222	245	2,5	20	194	0,22	MBL 40
	226	262	2,5	20	194	0,28	MB 40

MS locking clips
B 20 – 70 mm

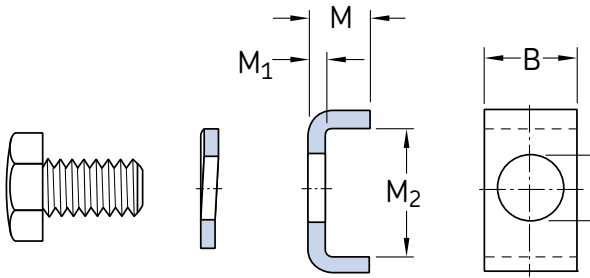

Dimensions					Mass	Designations Locking clip	Appertaining hexagon headed bolt	spring washer to DIN 128
B	M	M ₁	M ₂	M ₃				
mm					kg	–		
20	12	4	13,5	7	0,022	MS 3044	M 6×12	A 6
	12	4	17,5	9	0,024	MS 3052-48	M 8×16	A 8
24	12	4	17,5	9	0,030	MS 3056	M 8×16	A 8
	12	4	20,5	9	0,033	MS 3060	M 8×16	A 8
	15	5	21	9	0,046	MS 3068-64	M 8×16	A 8
28	15	5	20	9	0,051	MS 3072	M 8×16	A 8
	15	5	24	12	0,055	MS 3080-76	M 10×20	A 10
32	15	5	24	12	0,063	MS 3084	M 10×20	A 10
	15	5	28	14	0,067	MS 3092-88	M 12×25	A 12
36	15	5	28	14	0,076	MS 30/500-96	M 12×25	A 12
40	21	7	29	18	0,15	MS 30/560	M 16×30	A 16
	21	7	34	18	0,14	MS 30/600-530	M 16×30	A 16
45	21	7	34	18	0,17	MS 30/630	M 16×30	A 16
	21	7	39	18	0,19	MS 30/670	M 16×30	A 16
50	21	7	39	18	0,21	MS 30/710	M 16×30	A 16
55	21	7	39	18	0,23	MS 30/800-750	M 16×30	A 16
60	21	7	44	22	0,26	MS 30/900-850	M 20×40	A 20
	21	7	46	22	0,26	MS 30/950	M 20×40	A 20
	21	7	51	22	0,28	MS 30/1000	M 20×40	A 20
24	12	4	30,5	12	0,040	MS 3160	M 10×20	A 10
	15	5	31	12	0,055	MS 3164	M 10×20	A 10
28	15	5	38	14	0,069	MS 3172-68	M 12×25	A 12
32	15	5	40	14	0,083	MS 3176	M 12×25	A 12
	15	5	45	18	0,089	MS 3184-80	M 16×30	A 16
36	15	5	43	18	0,097	MS 3192-88	M 16×30	A 16
	15	5	53	18	0,11	MS 3196	M 16×30	A 16
40	15	5	45	18	0,11	MS 31/500	M 16×30	A 16
	21	7	51	22	0,19	MS 31/530	M 20×40	A 20

Dimensions					Mass	Designations Locking clip	Appertaining hexagon headed bolt	spring washer to DIN 128
B	M	M ₁	M ₂	M ₃				
mm					kg	–		
45	21	7	54	22	0,22	MS 31/600-560	M 20×40	A 20
50	21	7	61	22	0,27	MS 31/630	M 20×40	A 20
	21	7	66	22	0,28	MS 31/670	M 20×40	A 20
55	21	7	69	26	0,32	MS 31/710	M 24×50	A 24
60	21	7	70	26	0,35	MS 31/800-750	M 24×50	A 24
70	21	7	71	26	0,41	MS 31/850	M 24×50	A 24
	21	7	76	26	0,41	MS 31/900	M 24×50	A 24
	21	7	78	26	0,42	MS 31/950	M 24×50	A 24
	21	7	88	26	0,50	MS 31/1000	M 24×50	A 24

Lock nuts with integral locking device

These lock nuts of the KMK design (→ **fig. 9**) have an integral locking device, which takes the form of a pressure plate, the surface of which has a threaded profile. The pressure plate is pressed against the shaft thread by a grub screw, thus locking the nut in position.

Mounting and dismounting are simple and the axial location effective and reliable. Neither additional locking washer nor keyway in the shaft is required. The KMK nuts can be re-used.

The KMK nuts have slots in the outside diameter so that they can be tightened using a hook spanner. A hexagonal wrench is needed to tighten the grub screw. Appropriate sizes of spanner and key are provided in the product table. Tighten the grub screw, until the recommended tightening torque quoted in the product table is obtained.

Dimensions

The dimensions and the thread of the KMK nuts are in accordance with ISO 2982-2:2001, except for the width. The grub screw corresponds to ISO 4026:1993, material class 45H.

Tolerances

The metric ISO thread is machined to tolerance 5H according to ISO 965-3:1998.

Material

SKF lock nuts in the KMK series are made of steel and are phosphated and protected by a solventless rust inhibitor.

Mating shaft threads

SKF recommends that the mating thread on the shaft to be made to 6g according to ISO 965-3:1998.

Fig. 9

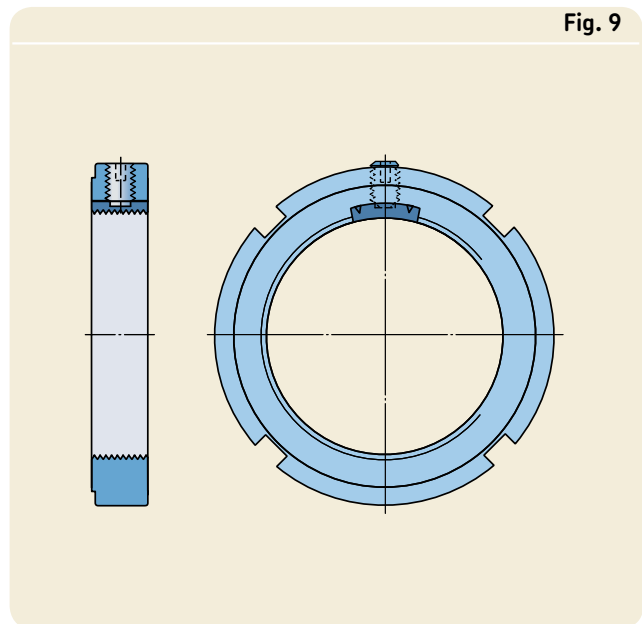

KMK lock nuts with integral locking device
M 10×0,75 – M 100×2

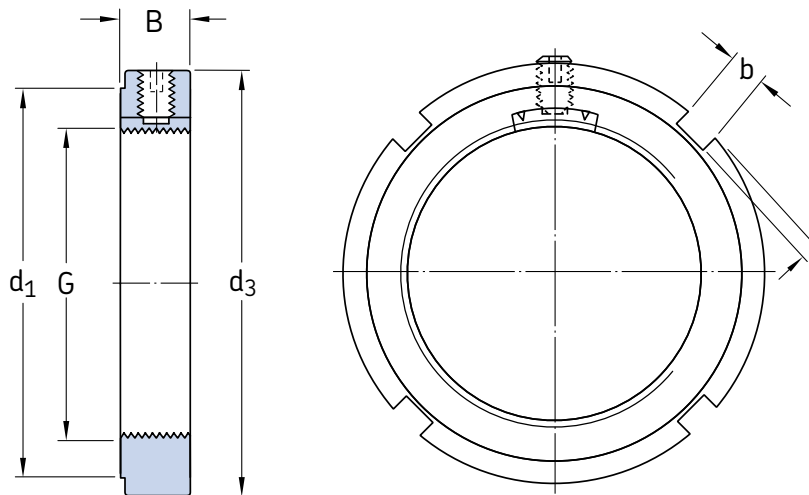

Dimensions						Axial load carrying capacity static	Loosening torque	Mass	Designations Lock nut	Appropriate spanner	Grub screw	
G	d ₁	d ₃	B	b	h						Size	Recomm. tightening torque
mm						kN	Nm	kg	–	–	Nm	
M 10×0,75	16	20	9	3	2	9,8	6	0,016	KMK 0	–	M 5	4
M 12×1	18	22	9	3	2	11,8	9	0,018	KMK 1	HN 1	M 5	4
M 15×1	21	25	9	4	2	14,6	12	0,021	KMK 2	HN 2	M 5	4
M 17×1	24	28	9	4	2	19,6	13	0,027	KMK 3	HN 3	M 5	4
M 20×1	28	32	9	4	2	24	16	0,030	KMK 4	HN 4	M 5	4
M 25×1,5	34	38	9	5	2	31,5	29	0,030	KMK 5	HN 5	M 5	4
M 30×1,5	41	45	9	5	2	36,5	35	0,060	KMK 6	HN 6	M 5	4
M 35×1,5	48	52	9	5	2	50	40	0,070	KMK 7	HN 7	M 5	4
M 40×1,5	53	58	11	6	2,5	62	67	0,11	KMK 8	HN 8	M 6	8
M 45×1,5	60	65	11	6	2,5	78	76	0,14	KMK 9	HN 9	M 6	8
M 50×1,5	65	70	13	6	2,5	91,5	84	0,18	KMK 10	HN 10	M 6	8
M 55×2	69	75	13	7	3	91,5	172	0,19	KMK 11	HN 11	M 8	18
M 60×2	74	80	13	7	3	95	188	0,20	KMK 12	HN 12	M 8	18
M 65×2	79	85	14	7	3	108	203	0,24	KMK 13	HN 13	M 8	18
M 70×2	85	92	14	8	3,5	118	219	0,28	KMK 14	HN 14	M 8	18
M 75×2	91	98	14	8	3,5	134	235	0,33	KMK 15	HN 15	M 8	18
M 80×2	98	105	18	8	3,5	173	378	0,45	KMK 16	HN 16	M 8	18
M 85×2	103	110	18	8	3,5	190	401	0,52	KMK 17	HN 17	M 10	35
M 90×2	112	120	18	10	4	216	425	0,65	KMK 18	HN 18	M 10	35
M 95×2	117	125	20	10	4	236	448	0,76	KMK 19	HN 19	M 10	35
M 100×2	122	130	20	10	4	255	472	0,80	KMK 20	HN 20	M 10	35

Lock nuts with locking screw

Lock nuts with locking screw (→ **fig. 10**) are designated KMFE. The locking screw presses a small part of the nut thread onto the shaft thread and prevents the nut from turning.

Mounting and dismounting are simple and the axial location effective and reliable. Neither additional locking washers nor keyway in the shaft are required. The KMFE nuts can be re-used.

The KMFE nuts have slots in the outside diameter so that they can be tightened using a hook or impact spanner. A hexagonal wrench is needed to tighten the grub screw. Appropriate sizes of the spanner are provided in the product table. Tighten the grub screw, until the recommended tightening torque quoted in the product table is obtained.

Dimensions

The dimensions and the thread of KMFE nuts are in accordance with ISO 2982-2:1995, except for the width. The grub screw correspond to ISO 4026:1993, material class 45H.

Tolerances

The metric ISO thread is machined to tolerance 5H according to ISO 965-3:1998.

Material

SKF lock nuts in the KMFE series are made of steel and are protected by a solventless rust inhibitor.

Mating shaft threads

SKF recommends that the mating thread on the shaft be made to 6g according to ISO 965-3:1998.

Fig. 10

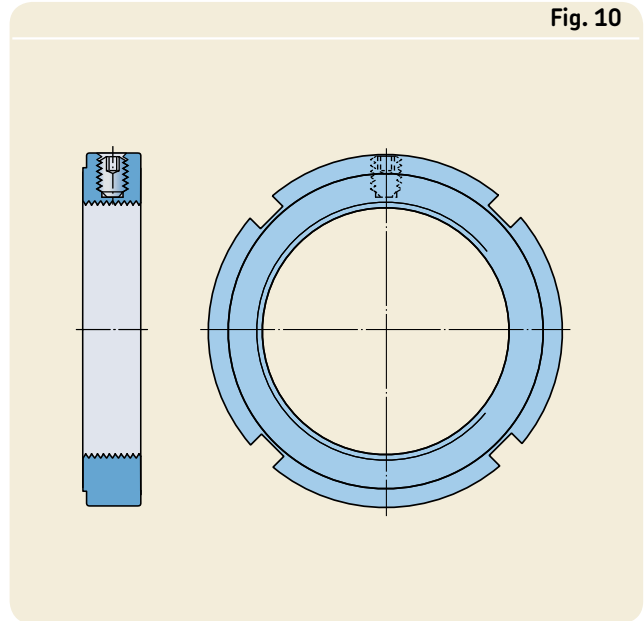

**KMFE lock nuts with locking screw
M 20×1 – M 130×2**

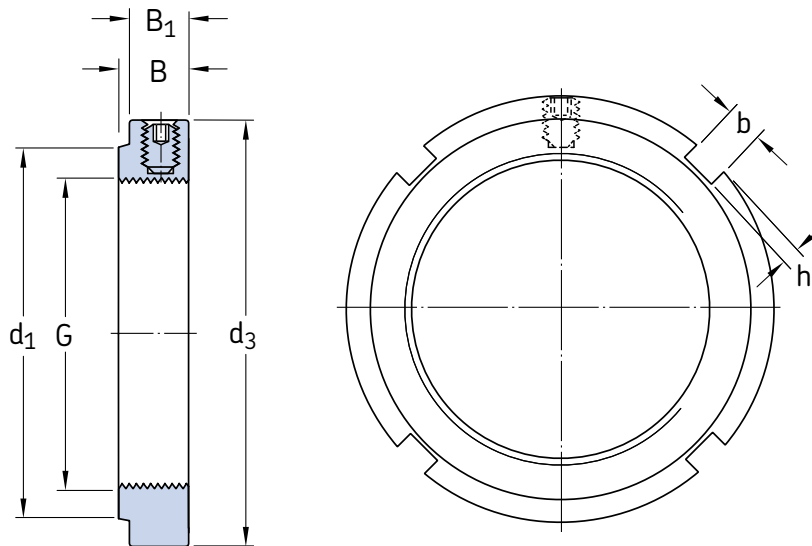

Dimensions							Axial load carrying capacity static	Loos- ening torque	Mass kg	Designations		Grub screw	
G	d ₁	d ₃	B	B ₁	b	h				Lock nut	Appro- priate spanner	Size	Recomm. tightening torque
mm							kN	Nm	kg	–	–	Nm	
M 20×1	26	32	9,5	8,5	4	2	24	28	0,031	KMFE 4	HN 4	M 5	4
M 25×1,5	31	38	10,5	8,5	5	2	31,5	35	0,042	KMFE 5	HN 5	M 5	4
M 30×1,5	36	45	10,5	8,5	5	2	36,5	42	0,058	KMFE 6	HN 6	M 5	4
M 35×1,5	42,5	52	11,5	8,5	5	2	50	49	0,080	KMFE 7	HN 7	M 5	4
M 40×1,5	47	58	13	10	6	2,5	62	80	0,11	KMFE 8	HN 8	M 6	8
M 45×1,5	53	65	13	10	6	2,5	78	94	0,14	KMFE 9	HN 9	M 6	8
M 50×1,5	57,5	70	14	11	6	2,5	91,5	100	0,16	KMFE 10	HN 10	M 6	8
M 55×2	64	75	14	11	7	3	91,5	110	0,18	KMFE 11	HN 11	M 6	8
M 60×2	69	80	14	11	7	3	95	120	0,19	KMFE 12	HN 12	M 6	8
M 65×2	76	85	15	12	7	3	108	130	0,23	KMFE 13	HN 13	M 6	8
M 70×2	79	92	15	12	8	3,5	118	140	0,26	KMFE 14	HN 14	M 6	8
M 75×2	85	98	16	13	8	3,5	134	150	0,32	KMFE 15	HN 15	M 6	8
M 80×2	91,5	105	18	15	8	3,5	173	300	0,42	KMFE 16	HN 16	M 8	18
M 85×2	98	110	19	15	8	3,5	190	315	0,46	KMFE 17	HN 17	M 8	18
M 90×2	102	120	19	15	10	4	216	335	0,58	KMFE 18	HN 18	M 8	18
M 95×2	110	125	20	16	10	4	236	355	0,66	KMFE 19	HN 19	M 8	18
M 100×2	112	130	21	17	10	4	255	370	0,71	KMFE 20	HN 20	M 8	18
M 105×2	112	140	21	17	12	5	290	390	0,85	KMFE 21	HN 21	M 8	18
M 110×2	122	145	21,5	17,5	12	5	310	410	0,93	KMFE 22	HN 22	M 8	18
M 115×2	126	150	25	20	12	5	315	645	1,11	KMFE 23	TMFN 23-30	M 10	35
M 120×2	130	155	26	20	12	5	340	675	1,16	KMFE 24	TMFN 23-30	M 10	35
M 125×2	136	160	27	21	12	5	360	700	1,26	KMFE 25	TMFN 23-30	M 10	35
M 130×2	141	165	28	21	12	5	365	730	1,33	KMFE 26	TMFN 23-30	M 10	35

Precision lock nuts with locking pins

SKF precision lock nuts were originally developed for use with precision bearings and their dimensions were chosen accordingly.

Precision lock nuts have three locking pins equally spaced around the circumference. These pins are pressed against the shaft by grub screws and prevent the nut from turning. The locking pins and grub screws are arranged at the same angle to the shaft as that of the thread flanks. The ends of the pins are machined with the nut thread and as a result also have a threaded profile. As the locking pins are not deformed, the nuts retain their high precision irrespective of the frequency with which they are mounted and dismantled. Additional locking washers or keyways in the shaft are not needed.

SKF precision lock nuts are available in two designs:

- KMT lock nuts (→ **fig. 11**) are designed as slotted nuts and the smaller sizes up to and including size 15 are also produced with two diametrically opposed flats to take spanners. They are intended for applications where high precision, simple assembly and reliable locking are required.

- KMTA lock nuts (→ **fig. 12**) have a different external shape from that of KMT nuts and in part a different thread pitch. They have a cylindrical outside surface and are primarily intended for applications where space is limited. As the outside surface is cylindrical the nut can also be used to form part of a gap-type seal. Holes around the circumference and in one side face facilitate mounting.

Precision lock nuts are adjustable. The three equally spaced locking pins enable the nut to be accurately positioned at right angles to the shaft or they can be used to adjust for inaccuracies or deviations of other components which are to be located on the shaft.

Dimensions

The KMT and KMTA nuts have a metric ISO thread according to ISO 965-3:1998.

Tolerances

The metric ISO thread is machined to tolerance 5H according to ISO 965-3:1998. The maximum runout between the thread and the locating face is 0,005 mm for nuts up to and including size 26.

Fig. 11

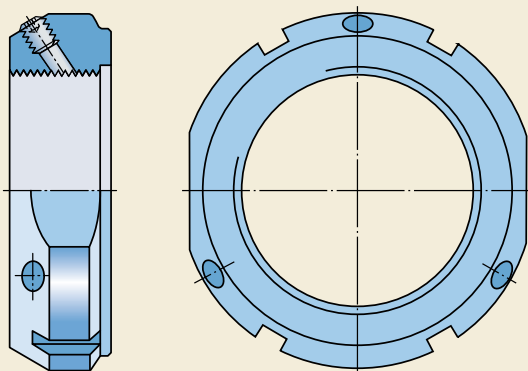
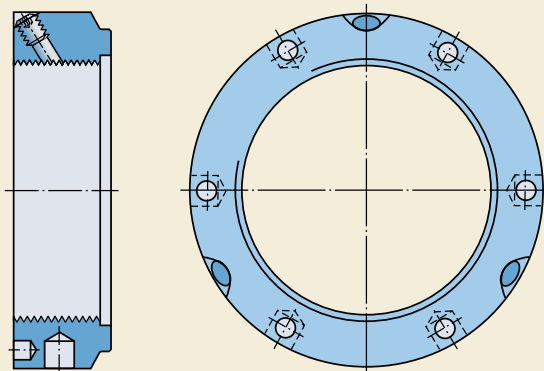

Fig. 12



Material

SKF lock nuts in the KMT and KMTA series are made of high-strength steel and are phosphated and protected by a solventless rust inhibitor.

Mating shaft threads

SKF recommends that the mating thread on the shaft be made to 6g according to ISO 965-3:1998.

Mounting

KMT lock nuts have slots around the circumference with two diametrically opposed flats on all nuts up to and including size 15. Various types of spanners can be used depending on the nut size, including hook and impact spanners. Appropriate sizes of spanners are provided in the product table.

KMTA lock nuts can be tightened using a pin wrench with a stud to engage one of the holes in the circumference. Alternatively a pin-type face spanner or a tommy bar can be used. Appropriate spanners according to DIN 1810:1979 are provided in the product table.

To lock the KMT and KMTA nuts, the grub screws should first be gently tightened until the thread of the locking pin engages the shaft thread. The grub screws should then be firmly tightened until the recommended tightening torque quoted in the product tables is obtained.

If it is necessary to correct for any misalignment between the abutment surfaces of the nut and adjacent component, the grub screw at the position of greatest deviation should first be loosened and the other two screws should be tightened to an equal degree. The loosened screw should then be retightened. If this correction for the misalignment is found to be inadequate, the procedure should be repeated until the desired accuracy has been achieved. This can be checked using a dial gauge.

Dismounting

When dismantling KMT and KMTA lock nuts the locking pins may still firmly engage the shaft thread even after the grub screws have been loosened. Light blows with a rubber hammer to the nut in the vicinity of the grub screws will serve to loosen the pins. The nuts can then be unscrewed easily from the shaft thread.

KMT precision lock nuts with locking pins M 10×0,75 – M 200×3

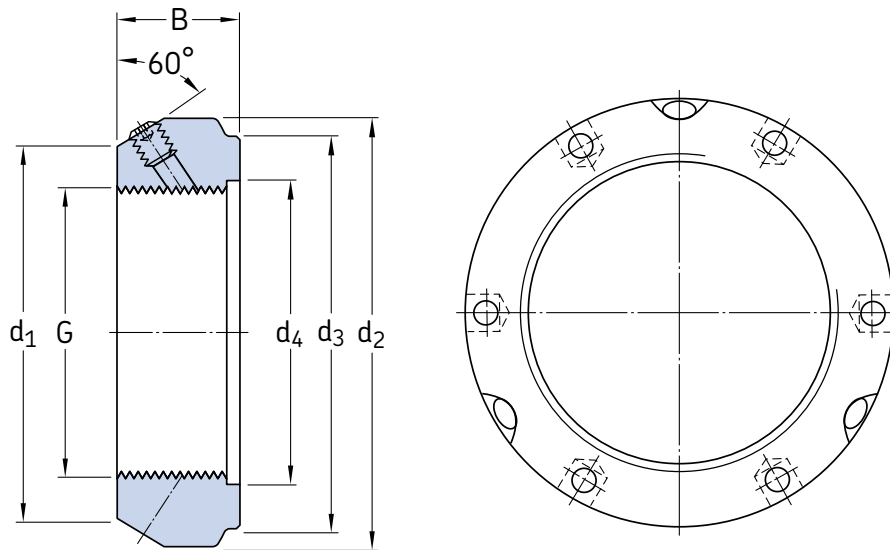

Dimensions										Axial load carrying capacity static	Loos- ening torque	Mass	Designations		Grub screws	
G	d ₁	d ₂	d ₃	d ₄	B	b	h	M	Lock nut				Appropriate spanner	Size	Recomm. tightening torque	
mm										kN	Nm	kg	–	–	Nm	
M 10×0,75	21	28	23	11	14	4	2	24	35	15	0,045	KMT 0	HN 2/3	M 5	4,5	
M 12×1	23	30	25	13	14	4	2	27	40	18	0,050	KMT 1	HN 3	M 5	4,5	
M 15×1	26	33	28	16	16	4	2	30	60	20	0,075	KMT 2	HN 4	M 5	4,5	
M 17×1	29	37	33	18	18	5	2	34	80	25	0,10	KMT 3	HN 4	M 6	8	
M 20×1	32	40	35	21	18	5	2	36	90	35	0,11	KMT 4	HN 5	M 6	8	
M 25×1,5	36	44	39	26	20	5	2	41	130	45	0,13	KMT 5	HN 5	M 6	8	
M 30×1,5	41	49	44	32	20	5	2	46	160	55	0,16	KMT 6	HN 6	M 6	8	
M 35×1,5	46	54	49	38	22	5	2	50	190	65	0,19	KMT 7	HN 7	M 6	8	
M 40×1,5	54	65	59	42	22	6	2,5	60	210	80	0,30	KMT 8	HN 8/9	M 8	18	
M 45×1,5	60	70	64	48	22	6	2,5	65	240	95	0,33	KMT 9	HN 9/10	M 8	18	
M 50×1,5	64	75	68	52	25	7	3	70	300	115	0,40	KMT 10	HN 10/11	M 8	18	
M 55×2	74	85	78	58	25	7	3	80	340	225	0,54	KMT 11	HN 12/13	M 8	18	
M 60×2	78	90	82	62	26	8	3,5	85	380	245	0,61	KMT 12	HN 13	M 8	18	
M 65×2	83	95	87	68	28	8	3,5	90	460	265	0,71	KMT 13	HN 14	M 8	18	
M 70×2	88	100	92	72	28	8	3,5	95	490	285	0,75	KMT 14	HN 15	M 8	18	
M 75×2	93	105	97	77	28	8	3,5	100	520	305	0,80	KMT 15	HN 15/16	M 8	18	
M 80×2	98	110	100	83	32	8	3,5	–	620	325	0,90	KMT 16	HN 16/17	M 8	18	
M 85×2	107	120	110	88	32	10	4	–	650	660	1,15	KMT 17	HN 17/18	M 10	35	
M 90×2	112	125	115	93	32	10	4	–	680	720	1,20	KMT 18	HN 18/19	M 10	35	
M 95×2	117	130	120	98	32	10	4	–	710	780	1,25	KMT 19	HN 19/20	M 10	35	
M 100×2	122	135	125	103	32	10	4	–	740	840	1,30	KMT 20	HN 20	M 10	35	

Dimensions								Axial load carrying capacity static	Loos- ening torque	Mass	Designations		Grub screws	
G	d ₁	d ₂	d ₃	d ₄	B	b	h				Lock nut	Appropriate spanner	Size	Recomm. tightening torque
mm								kN	Nm	kg	–	–	Nm	
M 110×2	132	145	134	112	32	10	4	800	960	1,45	KMT 22	HN 22	M 10	35
M 120×2	142	155	144	122	32	10	4	860	1 080	1,60	KMT 24	TMFN 23-30	M 10	35
M 130×2	152	165	154	132	32	12	5	920	1 200	1,70	KMT 26	TMFN 23-30	M 10	35
M 140×2	162	175	164	142	32	14	6	980	1 320	1,80	KMT 28	TMFN 23-30	M 10	35
M 150×2	172	185	174	152	32	14	6	1 040	1 440	1,95	KMT 30	TMFN 23-30	M 10	35
M 160×3	182	195	184	162	32	14	6	1 100	1 600	2,10	KMT 32	TMFN 30-40	M 10	35
M 170×3	192	205	192	172	32	14	6	1 160	1 750	2,20	KMT 34	TMFN 30-40	M 10	35
M 180×3	202	215	204	182	32	16	7	1 220	1 900	2,30	KMT 36	TMFN 30-40	M 10	35
M 190×3	212	225	214	192	32	16	7	1 280	2 050	2,40	KMT 38	TMFN 30-40	M 10	35
M 200×3	222	235	224	202	32	18	8	1 340	2 300	2,50	KMT 40	TMFN 30-40	M 10	35

KMTA precision lock nuts with locking pins
M 25×1,5 – M 200×3

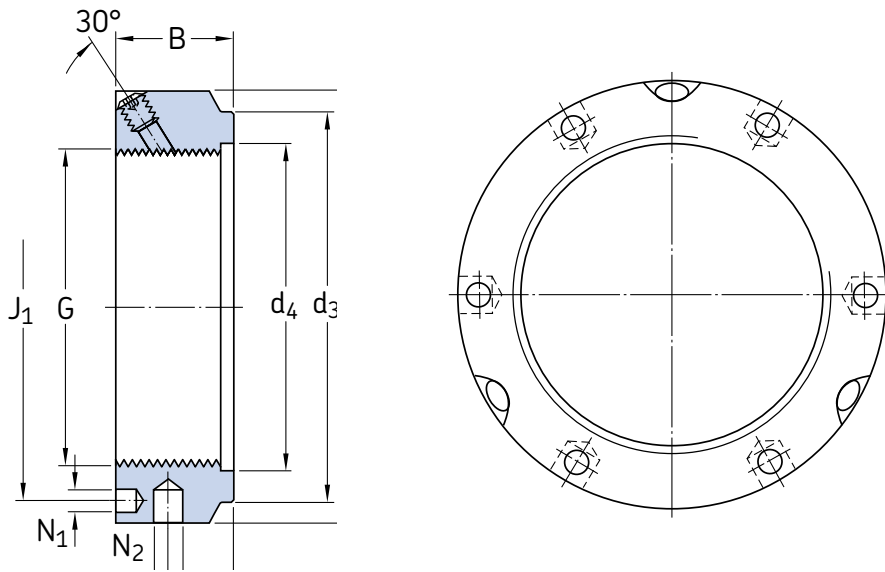

Dimensions									Axial load carrying capacity static	Loosening torque	Mass	Designations Lock nut	Appropriate spanner	Grub screws	
G	d ₂	d ₃	d ₄	B	J ₁	J ₂	N ₁	N ₂						Size	Recomm. tightening torque
mm									kN	Nm	kg	–	–	Nm	
M 25×1,5	42	35	26	20	32,5	11	4,3	4	130	45	0,13	KMTA 5	B 40-42	M 6	8
M 30×1,5	48	40	32	20	40,5	11	4,3	5	160	55	0,16	KMTA 6	B 45-50	M 6	8
M 35×1,5	53	47	38	20	45,5	11	4,3	5	190	65	0,19	KMTA 7	B 52-55	M 6	8
M 40×1,5	58	52	42	22	50,5	12	4,3	5	210	80	0,23	KMTA 8	B 58-62	M 6	8
M 45×1,5	68	58	48	22	58	12	4,3	6	240	95	0,33	KMTA 9	B 68-75	M 6	8
M 50×1,5	70	63	52	24	61,5	13	4,3	6	300	115	0,34	KMTA 10	B 68-75	M 6	8
M 55×1,5	75	70	58	24	66,5	13	4,3	6	340	135	0,37	KMTA 11	B 68-75	M 6	8
M 60×1,5	84	75	62	24	74,5	13	5,3	6	380	150	0,49	KMTA 12	B 80-90	M 8	18
M 65×1,5	88	80	68	25	78,5	13	5,3	6	460	170	0,52	KMTA 13	B 80-90	M 8	18
M 70×1,5	95	86	72	26	85	14	5,3	8	490	285	0,62	KMTA 14	B 95-100	M 8	18
M 75×1,5	100	91	77	26	88	13	6,4	8	520	305	0,66	KMTA 15	B 95-100	M 8	18
M 80×2	110	97	83	30	95	16	6,4	8	620	325	1,00	KMTA 16	B 110-115	M 8	18
M 85×2	115	102	88	32	100	17	6,4	8	650	660	1,15	KMTA 17	B 110-115	M 10	35
M 90×2	120	110	93	32	108	17	6,4	8	680	720	1,20	KMTA 18	B 120-130	M 10	35
M 95×2	125	114	98	32	113	17	6,4	8	710	780	1,25	KMTA 19	B 120-130	M 10	35
M 100×2	130	120	103	32	118	17	6,4	8	740	840	1,30	KMTA 20	B 120-130	M 10	35
M 110×2	140	132	112	32	128	17	6,4	8	800	960	1,45	KMTA 22	B 135-145	M 10	35
M 120×2	155	142	122	32	140	17	6,4	8	860	1 080	1,85	KMTA 24	B 155-165	M 10	35
M 130×3	165	156	132	32	153	17	6,4	8	920	1 200	2,00	KMTA 26	B 155-165	M 10	35
M 140×3	180	166	142	32	165	17	6,4	10	980	1 320	2,45	KMTA 28	B 180-195	M 10	35
M 150×3	190	180	152	32	175	17	6,4	10	1 040	1 440	2,60	KMTA 30	B 180-195	M 10	35

Dimensions										Axial load carrying capacity static	Loos- ening torque	Mass	Designations		Grub screws	
G	d ₂	d ₃	d ₄	B	J ₁	J ₂	N ₁	N ₂	Lock nut				Appropriate spanner	Size	Recomm. tightening torque	
mm										kN	Nm	kg	–	–	Nm	
M 160×3	205	190	162	32	185	17	8,4	10	1 100	1 600	3,15	KMTA 32	B 205-220	M 10	35	
M 170×3	215	205	172	32	195	17	8,4	10	1 160	1 750	3,30	KMTA 34	B 205-220	M 10	35	
M 180×3	230	215	182	32	210	17	8,4	10	1 220	1 900	3,90	KMTA 36	B 230-245	M 10	35	
M 190×3	240	225	192	32	224	17	8,4	10	1 280	2 050	4,10	KMTA 38	B 230-245	M 10	35	
M 200×3	245	237	202	32	229	17	8,4	10	1 340	2 200	3,85	KMTA 40	B 230-245	M 10	35	



Bearing housings

SNL plumber block housings, 2, 3, 5 and 6 series	1033
Other bearing housings	1058
Large SNL plumber block housings	1058
SONL plumber block housings	1059
SDG plumber block housings	1060
SAF pillow (plummer) block housings	1061
SDAF pillow (plummer) block housings.....	1062
SBD plumber block housings	1063
TVN plumber block housings	1064
TN plumber block housings	1065
I-1200(00) flanged housings	1065
7225(00) flanged housings	1066
THD take-up housings.....	1067



Bearing housings

Bearing housings together with appropriate SKF bearings constitute economic, interchangeable bearing units that meet the demand for designs that are easy to maintain.

As a leading supplier of rolling bearings, SKF also produces bearing housings in a wide range of designs and sizes that are based on experience collected in all industrial areas. Among others, SKF bearing housings have the following advantages

- large assortment of design and sizes
- high quality of design and manufacture
- worldwide availability.

Plummer (pillow) block housings in the SNL 2, 3, 5 and 6 series are the most common housings and are shown in this catalogue with technical details. They have additional advantages

- short delivery times
- long term supply stability
- no minimum order quantities
- simplified ordering and stocking.

Other bearing housings in the SKF standard range, include

- split plummer (pillow) block housings
- one-piece plummer block housings
- flanged housings
- take-up housings.

They are only presented with their main design features. Publications with detailed information are noted and will be supplied on request.

The SKF manufacturing programme also includes special housings for particular applications, such as

- conveyors and drums
- roller beds and converters
- tube mills and rotary furnaces
- paper machines
- windmills
- pinions of open gears
- large electrical machines
- rudder post bearing arrangements
- ships' shafting support bearing arrangements.

For detailed information on these housings, please ask the SKF application engineering service and provide application details.

Besides bearing housings, SKF also supplies complete ready-to-mount bearing units, consisting of housing, bearing, and appropriate seals. These units are presented in the section "Bearing units" on **page 1115**.

SNL plummer block housings, 2, 3, 5 and 6 series

Design features	1034
Building block system.....	1034
Reinforced base.....	1034
Attachment.....	1034
Heat conduction.....	1034
Relubrication facility.....	1034
Caps and bases individually marked.....	1035
Mounting aid.....	1035
Indications for holes to accommodate other components.....	1035
Types of arrangement	1035
Bearings in the non-locating position.....	1035
Bearings in the locating position.....	1035
Seals	1036
Special design features	1036
Housing data – general	1037
Dimensions.....	1037
Tolerances.....	1037
Materials.....	1037
Corrosion protection.....	1037
Load carrying ability.....	1037
Lubrication	1037
How to order	1037
Example.....	1037
Product tables	1038
SNL plummer block housings for bearings on adapter sleeve.....	1038
SNL plummer block housings for bearings with cylindrical bore.....	1048

Design features

SNL plummer block housings (→ **fig. 1**) are the most popular of the wide range of SKF housings. Because of their versatility it is seldom necessary to resort to tailored housings for specific applications. The main design features are listed below. Further information on SNL plummer block housings can be obtained from

- the product brochure “SNL plummer block housings solve the housing problems”
- the “SKF Interactive Engineering Catalogue” on CD-ROM or online at www.skf.com.

Building block system

The basis of the SNL plummer block housing system consists of a number of housings of the same design but in different sizes. By combining these housings with different standard seals (→ **fig. 2**) a wide variety of housing variants, all belonging to the standard range, can be supplied. SNL plummer blocks can accommodate shaft diameters ranging from 20 to 160 mm.

Reinforced base

The housing base is reinforced with ribs and extra material surrounding the holes for the attachment bolts in order to improve seating on the base plate. The attachment bolts can be preloaded to give better location and do not deform the housing base or housing bore.

Attachment

SNL housings have two attachment bolt holes in the base as standard. Housings of size 511-609 and larger are also available with four cast attachment bolt holes as standard, designated FSNL. These larger housings are also available without attachment bolt holes, but only made of ductile cast iron (blank base, designated SSNLD).

Also the smaller housings below size 511-609 can be used for four bolt mounting. Cast indications show where to drill the additional holes.

Heat conduction

The extra ribs in the housing base provide additional surface area between the base and base plate to improve heat flow away from the bearing.

Relubrication facility

The housing caps of SNL housings are equipped with two drilled and tapped holes for grease nipples, which are closed by metallic plugs. One grease nipple is supplied as standard.

Cast indications mark three additional grease nipple locations for relubrication of the bearing or the seals.

Fig. 1

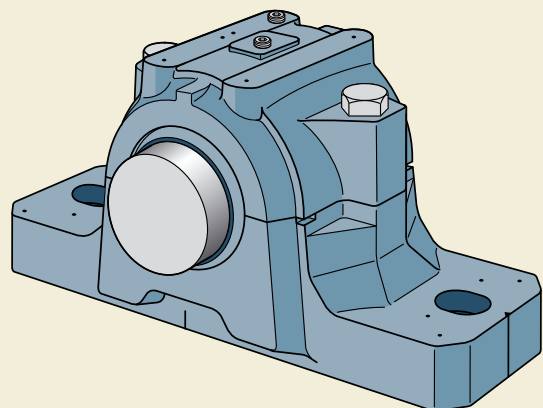
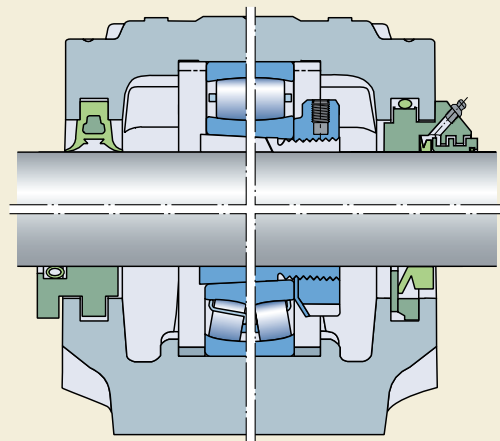

Fig. 2



Caps and bases individually marked

The housing base and cap are matched during manufacture and are not interchangeable. To prevent mixing, the same consecutive number is marked on the cap and base of each individual housing.

Mounting aid

To simplify mounting and make alignment more accurate, cast indications in the end faces of the housing base indicate the housing bore axis and the vertical axis.

Indications for holes to accommodate other components

Cast indications mark the positions where holes can be drilled for dowel pins, sensors for condition monitoring, or additional grease nipples.

Types of arrangement

Not only can different bearing types be incorporated in SNL plummer block housings, but they can also be arranged in different ways

- bearings with a tapered bore on an adapter sleeve on a smooth shaft (→ **fig. 3**) – SNL housings, 5 and 6 series (→ table starting on **page 1038**)
- bearings with a cylindrical bore on stepped shafts (→ **fig. 4**) – SNL housings, 2 and 3 series (→ table starting on **page 1048**).

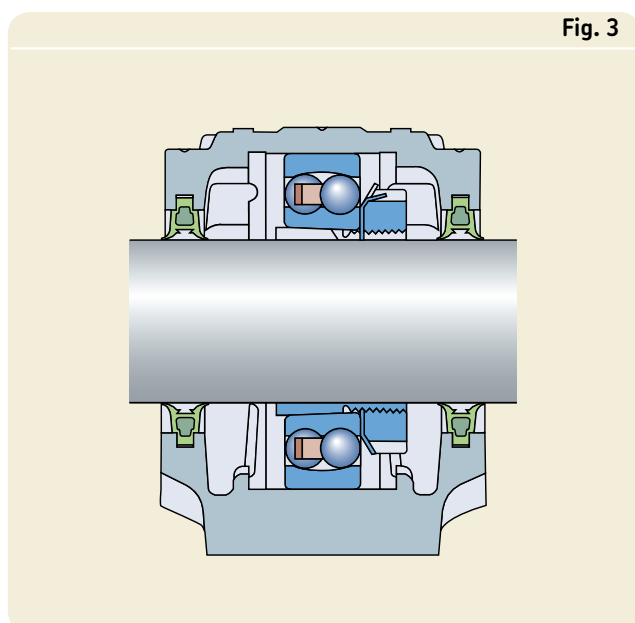

Bearings in the non-locating position

The bearing seatings in the housings are sufficiently wide to enable axial displacement of the bearing.

CARB bearings, which compensate axial displacement within the bearing, must always be secured in the housing bore with locating rings. In addition, please follow the recommendations in the section “Axial displacement” in the chapter “CARB toroidal roller bearings” (→ **page 787**).

Bearings in the locating position

For bearings in the locating position two locating rings of the same width have to be inserted on each side of the bearing. This means, locating bearings are placed in the middle of the housing seating.

The locating rings are identified by the prefix FRB followed by the size (width/outside diameter) in millimetres uncoded, e.g. FRB 11.5/100. Appropriate locating rings are listed together with the bearings in the product tables.

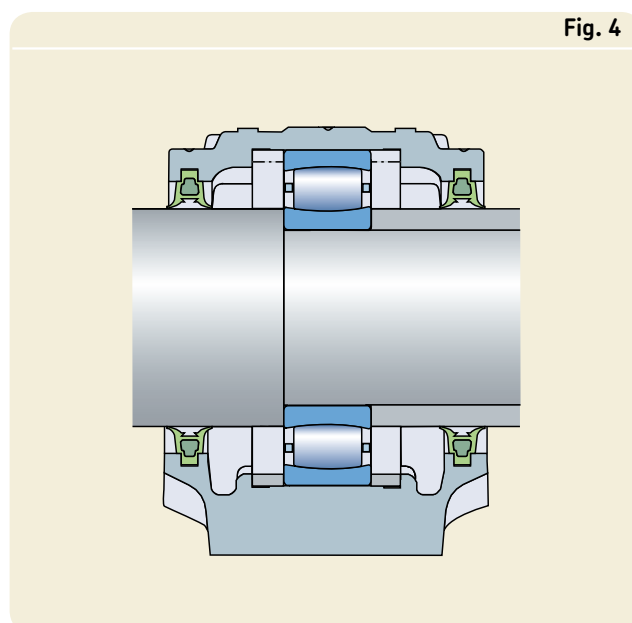

Seals

The following standard seals (→ **fig. 5**) are available for SNL plummer block housings

- double-lip seals TSN .. G design (**a**) for peripheral speeds up to 8 m/s and operating temperatures from -40 to $+100$ °C
- four-lip seals TSN .. L design (**b**) for peripheral speeds up to 13 m/s and operating temperatures from -40 to $+100$ °C
- V-ring seals TSN .. A design (**c**) for peripheral speeds up to 7 m/s, under special conditions up to 12 m/s and operating temperatures from -40 to $+100$ °C
- labyrinth seals TSN .. S design (**d**) for unlimited peripheral speeds and operating temperatures from -50 to $+200$ °C
- taconite heavy-duty seals with radial labyrinth TSN .. ND design (**e**) for peripheral speeds up to 12 m/s and operating temperatures from -40 to $+100$ °C.

All seals are fully interchangeable because no modifications to the housing are required.

For housings mounted on the end of a shaft, end covers in the ASNH series are available (**f**).

Special design features

On request SNL plummer block housings can be supplied with special design features deviating from the standard. The essential features are listed below. They are indicated by designation suffixes.

- V** Housing with grease escape hole
- T** Drilled and tapped hole 1/4-28 UNF on one side of the housing cap with grease nipple AH 1/4-28 SAE-LT for relubrication of seals
- TD** Drilled and tapped hole 1/4-28 UNF on both sides of the housing cap with two grease nipples AH 1/4-28 SAE-LT for relubrication of seals
- SN** Housing with drilled and tapped hole for sensor
- K7** Seating in the housing machined to tolerance K7

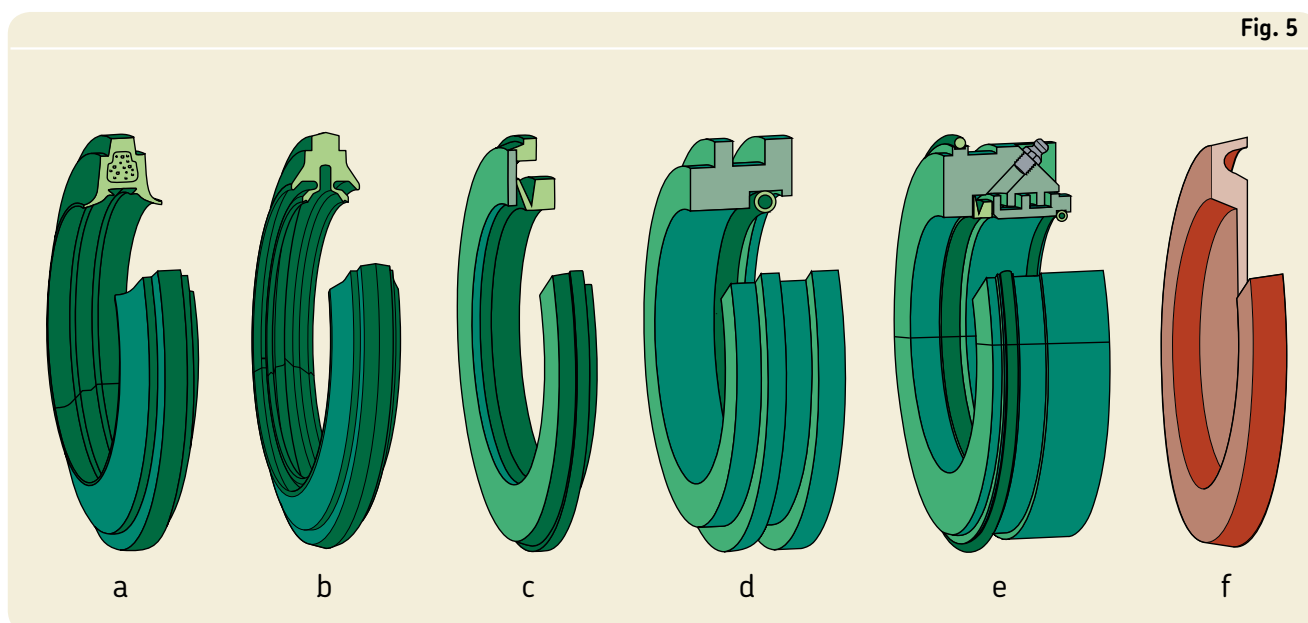

Fig. 5

Housing data – general

Dimensions

The boundary dimensions of an SNL plummer block housing conform to ISO 113:1999. The housings are dimensionally interchangeable with earlier SN, SNA, and SNH housings.

Tolerances

The tolerance limits for the centre height H_1 (of the housing bore above the support surface) are to js11. The bearing seating in the housing is machined to tolerance G7 as standard.

Materials

SNL plummer block housings are made of grey cast iron. For applications where the strength of grey cast iron is inadequate, dimensionally equivalent housings made of spheroidal graphite cast iron can be supplied. These housings are only available with four cast attachment bolt holes (series FSNLD) or without any holes in the base (series SSNLD).

Corrosion protection

SNL plummer block housings are painted as standard in accordance with ISO 12944-2: 1998, environmental Class C2. Black colour: RAL 9005. Blank surfaces are protected by a solventless rust inhibitor.

Load carrying ability

SNL plummer block housings are intended for loads acting vertically towards the base plate (support). In this case, loads are limited only by the load limits of the bearing. If loads acting in other directions occur, check that the magnitude of the load is permissible for the housing, the bolts joining the housing cap and base, and for the attachment bolts.

Lubrication

SNL plummer block housings with standard seals are designed for grease lubrication. For oil lubrication, modified SNL housings are available. These housings are supplied only together with the seals specially developed for oil lubrication.

How to order

The housing, seals, end cover and locating rings must be ordered individually. Bearings and any necessary sleeves must also be ordered individually.

Example

Two plummer block housings with four-lip seals are required for 22212 EK spherical roller bearings on H 312 adapter sleeves. One housing should be for the non-locating bearing position at the end of a shaft, and the other housing for the locating bearing position and a through shaft. The following items must be ordered

- 2 SNL 512-610 plummer block housings
- 2 TSN 512 L four-lip seal packs (each pack contains two seals)
- 1 ASNH 512-610 end cover
- 2 FRB 10/110 locating rings and
- 2 22212 EK bearings
- 2 H 312 sleeves

**SNL plummer block housings
for bearings on adapter sleeve**
d_a 20 – 35 mm

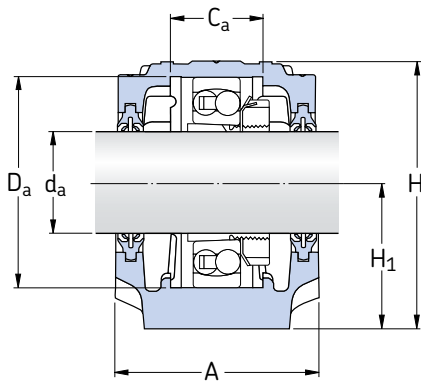

Four-lip seals
L design

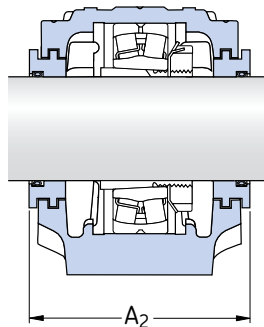

Labyrinth seals
S design

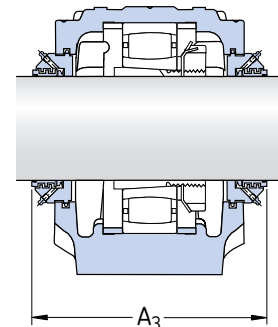

Taconite seals
ND design

Shaft d _a	Housing Dimensions											Mass kg	Designations Housing complete with two seals	Components Housing only	Seals	End cover
	A	A ₁	H	H ₁	H ₂	J	L	N	N ₁	G	mm					
20	67	46	74	40	19	130	165	20	15	12	1,45	SNL 505 TG SNL 505 TA SNL 505 TS SNL 505 TND	SNL 505 SNL 505 SNL 505 SNL 505	TSN 505 G TSN 505 A TSN 505 S TSN 505 ND	ASNH 505 ASNH 505 ASNH 505 ASNH 505	
	77	52	89	50	22	150	185	20	15	12	2,00	SNL 605 TG SNL 605 TA SNL 605 TS SNL 605 TND	SNL 506-605 SNL 506-605 SNL 506-605 SNL 506-605	TSN 605 G TSN 605 A TSN 605 S TSN 605 ND	ASNH 506-605 ASNH 506-605 ASNH 506-605 ASNH 506-605	
25	77	52	89	50	22	150	185	20	15	12	2,00	SNL 506 TG SNL 506 TA SNL 506 TS SNL 506 TND	SNL 506-605 SNL 506-605 SNL 506-605 SNL 506-605	TSN 506 G TSN 506 A TSN 506 S TSN 506 ND	ASNH 506-605 ASNH 506-605 ASNH 506-605 ASNH 506-605	
	82	52	93	50	22	150	185	20	15	12	2,20	SNL 606 TG SNL 606 TA SNL 606 TS SNL 606 TND	SNL 507-606 SNL 507-606 SNL 507-606 SNL 507-606	TSN 606 G TSN 606 A TSN 606 S TSN 606 ND	ASNH 507-606 ASNH 507-606 ASNH 507-606 ASNH 507-606	
30	82	52	93	50	22	150	185	20	15	12	2,20	SNL 507 TL SNL 507 TA SNL 507 TS SNL 507 TND	SNL 507-606 SNL 507-606 SNL 507-606 SNL 507-606	TSN 507 L TSN 507 A TSN 507 S TSN 507 ND	ASNH 507-606 ASNH 507-606 ASNH 507-606 ASNH 507-606	
	85	60	108	60	25	170	205	20	15	12	2,90	SNL 607 TG SNL 607 TA SNL 607 TS SNL 607 TND	SNL 508-607 SNL 508-607 SNL 508-607 SNL 508-607	TSN 607 G TSN 607 A TSN 607 S TSN 607 ND	ASNH 508-607 ASNH 508-607 ASNH 508-607 ASNH 508-607	
35	85	60	108	60	25	170	205	20	15	12	2,90	SNL 508 TL SNL 508 TA SNL 508 TS SNL 508 TND	SNL 508-607 SNL 508-607 SNL 508-607 SNL 508-607	TSN 508 L TSN 508 A TSN 508 S TSN 508 ND	ASNH 508-607 ASNH 508-607 ASNH 508-607 ASNH 508-607	
	90	60	113	60	25	170	205	20	15	12	3,20	SNL 608 TG SNL 608 TA SNL 608 TS SNL 608 TND	SNL 510-608 SNL 510-608 SNL 510-608 SNL 510-608	TSN 608 G TSN 608 A TSN 608 S TSN 608 ND	ASNH 510-608 ASNH 510-608 ASNH 510-608 ASNH 510-608	

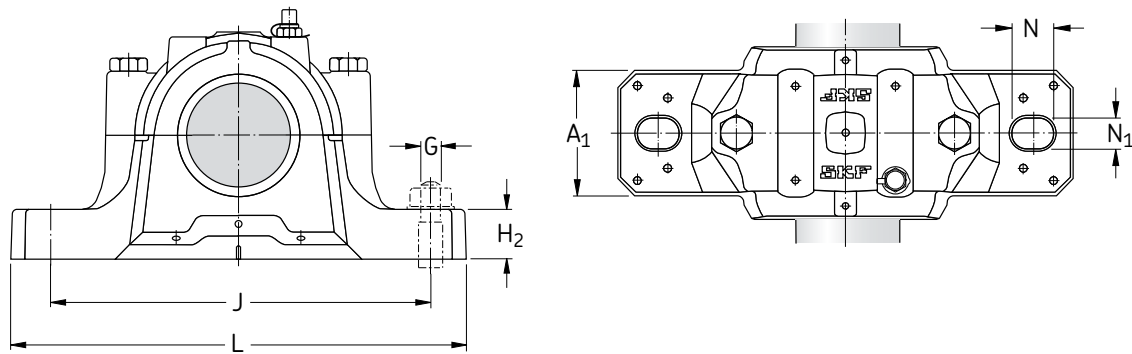

Shaft d_a	Bearing seating		Width across seal		Appropriate bearings and associated components					
	C_a	D_a	A_2	A_3	Self-aligning ball bearing	Adapter sleeve	Locating rings 2 per housing	Self-aligning ball bearing Spherical roller bearing CARB bearing	Adapter sleeve	Locating rings 2 per housing
mm	mm	mm	mm	mm	—					
20	25	52	80	125	1205 EK —	H 205 —	FRB 5/52 —	2205 EK 22205 EK C 2205 K	H 305 H 305 H 305 E	FRB 3.5/52 FRB 3.5/52 FRB 3.5/52
	32	62	89	135	1305 EK —	H 305 —	FRB 7.5/62 —	2305 EK —	H 2305 —	FRB 4/62 —
25	32	62	89	135	1206 EK —	H 206 —	FRB 8/62 —	2206 EK 22206 EK C 2206 K	H 306 H 306 H 306 E	FRB 6/62 FRB 6/62 FRB 6/62
	34	72	94	140	1306 EK 21306 CCK	H 306 H 306	FRB 7.5/72 FRB 7.5/72	2306 K —	H 2306 —	FRB 3.5/72 —
30	34	72	94	145	1207 EK —	H 207 —	FRB 8.5/72 —	2207 EK 22207 EK C 2207 K	H 307 H 307 H 307 E	FRB 5.5/72 FRB 5.5/72 FRB 5.5/72
	39	80	97	145	1307 EK 21307 CCK	H 307 H 307	FRB 9/80 FRB 9/80	2307 EK —	H 2307 —	FRB 4/80 —
35	39	80	97	150	1208 EK —	H 208 —	FRB 10.5/80 —	2208 EK 22208 EK C 2208 K	H 308 H 308 H 308 E	FRB 8/80 FRB 8/80 FRB 8/80
	41	90	102	150	1308 EK 21308 CCK	H 308 H 308	FRB 9/90 FRB 9/90	2308 EK 22308 EK	H 2308 H 2308	FRB 4/90 FRB 4/90

**SNL plummer block housings
for bearings on adapter sleeve**
d_a 40 – 55 mm

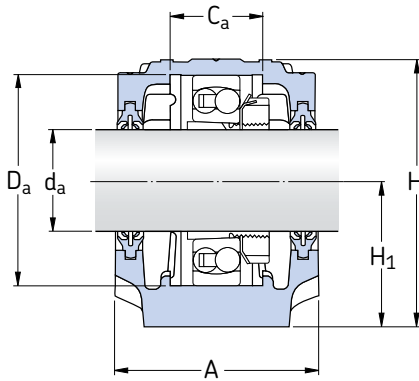

Four-lip seals
L design

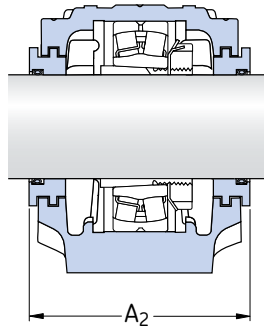

Labyrinth seals
S design

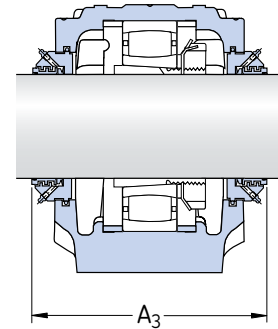

Taconite seals
ND design

Shaft d _a	Housing Dimensions											Mass kg	Designations Housing complete with two seals	Components Housing only	Seals	End cover
	A	A ₁	H	H ₁	H ₂	J	L	N	N ₁	G	mm					
40	85	60	109	60	25	170	205	20	15	12	2,90	SNL 509 TL SNL 509 TA SNL 509 TS SNL 509 TND	SNL 509 SNL 509 SNL 509 SNL 509	TSN 509 L TSN 509 A TSN 509 S TSN 509 ND	ASNH 509 ASNH 509 ASNH 509 ASNH 509	
	95	70	128	70	28	210	255	24	18	16	4,40	SNL 609 TG SNL 609 TA SNL 609 TS SNL 609 TND	SNL 511-609 SNL 511-609 SNL 511-609 SNL 511-609	TSN 609 G TSN 609 A TSN 609 S TSN 609 ND	ASNH 511-609 ASNH 511-609 ASNH 511-609 ASNH 511-609	
45	90	60	113	60	25	170	205	20	15	12	3,20	SNL 510 TL SNL 510 TA SNL 510 TS SNL 510 TND	SNL 510-608 SNL 510-608 SNL 510-608 SNL 510-608	TSN 510 L TSN 510 A TSN 510 S TSN 510 ND	ASNH 510-608 ASNH 510-608 ASNH 510-608 ASNH 510-608	
	105	70	134	70	30	210	255	24	18	16	5,10	SNL 610 TG SNL 610 TA SNL 610 TS SNL 610 TND	SNL 512-610 SNL 512-610 SNL 512-610 SNL 512-610	TSN 610 G TSN 610 A TSN 610 S TSN 610 ND	ASNH 512-610 ASNH 512-610 ASNH 512-610 ASNH 512-610	
50	95	70	128	70	28	210	255	24	18	16	4,40	SNL 511 TL SNL 511 TA SNL 511 TS SNL 511 TND	SNL 511-609 SNL 511-609 SNL 511-609 SNL 511-609	TSN 511 L TSN 511 A TSN 511 S TSN 511 ND	ASNH 511-609 ASNH 511-609 ASNH 511-609 ASNH 511-609	
	110	80	150	80	30	230	275	24	18	16	6,50	SNL 611 TG SNL 611 TA SNL 611 TS SNL 611 TND	SNL 513-611 SNL 513-611 SNL 513-611 SNL 513-611	TSN 611 G TSN 611 A TSN 611 S TSN 611 ND	ASNH 513-611 ASNH 513-611 ASNH 513-611 ASNH 513-611	
55	105	70	134	70	30	210	255	24	18	16	5,10	SNL 512 TL SNL 512 TA SNL 512 TS SNL 512 TND	SNL 512-610 SNL 512-610 SNL 512-610 SNL 512-610	TSN 512 L TSN 512 A TSN 512 S TSN 512 ND	ASNH 512-610 ASNH 512-610 ASNH 512-610 ASNH 512-610	
	115	80	156	80	30	230	280	24	18	16	7,00	SNL 612 TG SNL 612 TA SNL 612 TS SNL 612 TND	SNL 515-612 SNL 515-612 SNL 515-612 SNL 515-612	TSN 612 G TSN 612 A TSN 612 S TSN 612 ND	ASNH 515-612 ASNH 515-612 ASNH 515-612 ASNH 515-612	

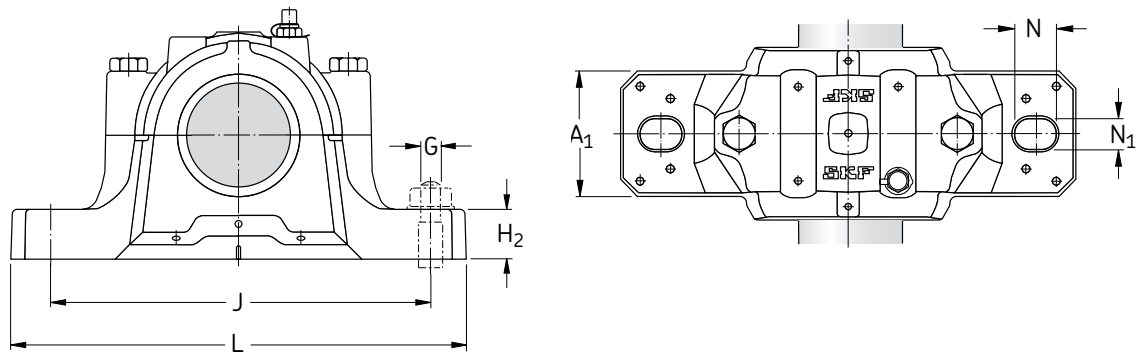

Shaft d_a	Bearing seating		Width across seal		Appropriate bearings and associated components					
	C_a	D_a	A_2	A_3	Self-aligning ball bearing	Adapter sleeve	Locating rings 2 per housing	Self-aligning ball bearing	Adapter sleeve	Locating rings 2 per housing
mm	mm	mm	mm	mm	mm	mm	mm	mm	mm	mm
40	30	85	97	150	1209 EK	H 209	FRB 5.5/85	2209 EK	H 309	FRB 3.5/85
					–	–	–	22209 EK	H 309	FRB 3.5/85
								C 2209 K	H 309 E	FRB 3.5/85
	44	100	107	155	1309 EK	H 309	FRB 9.5/100	2309 EK	H 2309	FRB 4/100
					21309 EK	H 309	FRB 9.5/100	22309 EK	H 2309	FRB 4/100
								–	–	–
45	41	90	102	155	1210 EK	H 210	FRB 10.5/90	2210 EK	H 310	FRB 9/90
					–	–	–	22210 EK	H 310	FRB 9/90
								C 2210 K	H 310 E	FRB 9/90
	48	110	117	165	1310 EK	H 310	FRB 10.5/110	2310 K	H 2310	FRB 4/110
					21310 EK	H 310	FRB 10.5/110	22310 EK	H 2310	FRB 4/110
								–	–	–
50	44	100	107	165	1211 EK	H 211	FRB 11.5/100	2211 EK	H 311	FRB 9.5/100
					–	–	–	22211 EK	H 311	FRB 9.5/100
								C 2211 K	H 311 E	FRB 9.5/100
	51	120	122	170	1311 EK	H 311	FRB 11/120	2311 K	H 2311	FRB 4/120
					21311 EK	H 311	FRB 11/120	22311 EK	H 2311	FRB 4/120
								–	–	–
55	48	110	117	175	1212 EK	H 212	FRB 13/110	2212 EK	H 312	FRB 10/110
					–	–	–	22212 EK	H 312	FRB 10/110
								C 2212 K	H 312 E	FRB 10/110
	56	130	127	175	1312EK	H 312	FRB 12.5/130	2312 K	H 2312	FRB 5/130
					21312 EK	H 312	FRB 12.5/130	22312 EK	H 2312	FRB 5/130
								–	–	–

**SNL plummer block housings
for bearings on adapter sleeve**
d_a 60 – 75 mm

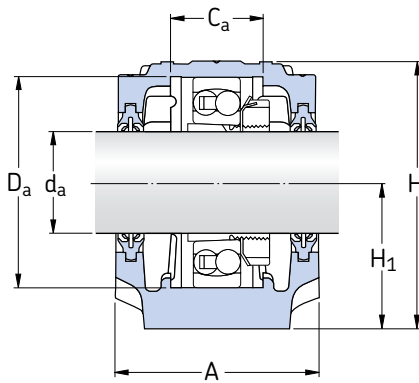

Four-lip seals
L design

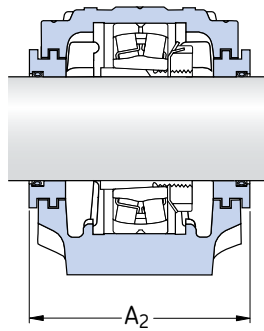

Labyrinth seals
S design

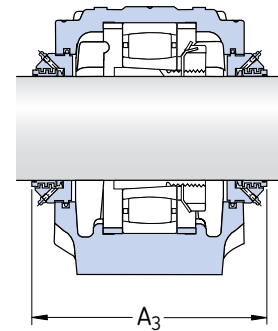

Taconite seals
ND design

Shaft d _a	Housing Dimensions										Mass kg	Designations Housing complete with two seals	Components Housing only	Seals	End cover
	A	A ₁	H	H ₁	H ₂	J	L	N	N ₁	G					
mm	mm														
60	110	80	150	80	30	230	275	24	18	16	6,50	SNL 513 TL SNL 513 TA SNL 513 TS SNL 513 TND	SNL 513-611 SNL 513-611 SNL 513-611 SNL 513-611	TSN 513 L TSN 513 A TSN 513 S TSN 513 ND	ASNH 513-611 ASNH 513-611 ASNH 513-611 ASNH 513-611
	120	90	177	95	32	260	315	28	22	20	9,50	SNL 613 TG SNL 613 TA SNL 613 TS SNL 613 TND	SNL 516-613 SNL 516-613 SNL 516-613 SNL 516-613	TSN 613 G TSN 613 A TSN 613 S TSN 613 ND	ASNH 516-613 ASNH 516-613 ASNH 516-613 ASNH 516-613
65	115	80	156	80	30	230	280	24	18	16	7,00	SNL 515 TL SNL 515 TA SNL 515 TS SNL 515 TND	SNL 515-612 SNL 515-612 SNL 515-612 SNL 515-612	TSN 515 L TSN 515 A TSN 515 S TSN 515 ND	ASNH 515-612 ASNH 515-612 ASNH 515-612 ASNH 515-612
	140	100	194	100	35	290	345	28	22	20	12,5	SNL 615 TG SNL 615 TA SNL 615 TS SNL 615 TND	SNL 518-615 SNL 518-615 SNL 518-615 SNL 518-615	TSN 615 G TSN 615 A TSN 615 S TSN 615 ND	ASNH 518-615 ASNH 518-615 ASNH 518-615 ASNH 518-615
70	120	90	177	95	32	260	315	28	22	20	9,50	SNL 516 TL SNL 516 TA SNL 516 TS SNL 516 TND	SNL 516-613 SNL 516-613 SNL 516-613 SNL 516-613	TSN 516 L TSN 516 A TSN 516 S TSN 516 ND	ASNH 516-613 ASNH 516-613 ASNH 516-613 ASNH 516-613
	145	100	212	112	35	290	345	28	22	20	13,7	SNL 616 TG SNL 616 TA SNL 616 TS SNL 616 TND	SNL 519-616 SNL 519-616 SNL 519-616 SNL 519-616	TSN 616 G TSN 616 A TSN 616 S TSN 616 ND	ASNH 519-616 ASNH 519-616 ASNH 519-616 ASNH 519-616
75	125	90	183	95	32	260	320	28	22	20	10,0	SNL 517 TL SNL 517 TA SNL 517 TS SNL 517 TND	SNL 517 SNL 517 SNL 517 SNL 517	TSN 517 L TSN 517 A TSN 517 S TSN 517 ND	ASNH 517 ASNH 517 ASNH 517 ASNH 517
	160	110	218	112	40	320	380	32	26	24	17,6	SNL 617 TG SNL 617 TA SNL 617 TS SNL 617 TND	SNL 520-617 SNL 520-617 SNL 520-617 SNL 520-617	TSN 617 G TSN 617 A TSN 617 S TSN 617 ND	ASNH 520-617 ASNH 520-617 ASNH 520-617 ASNH 520-617

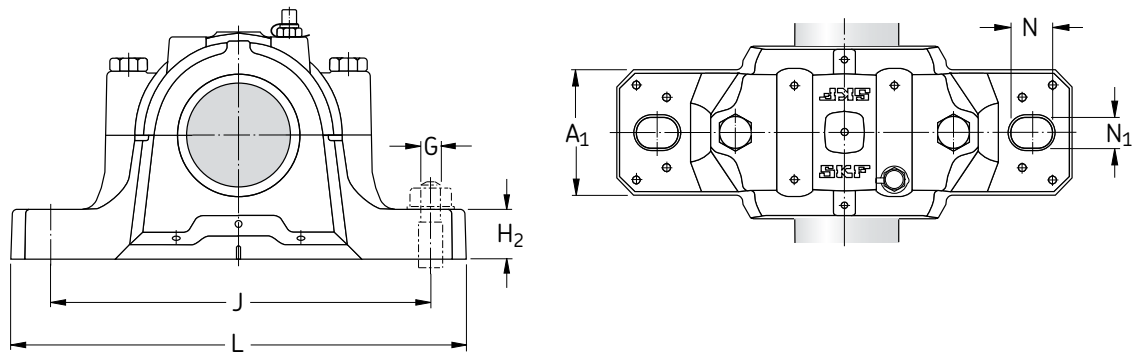

Shaft d_a	Bearing seating		Width across seal		Appropriate bearings and associated components						
	C_a	D_a	A_2	A_3	Self-aligning ball bearing	Adapter sleeve	Locating rings 2 per housing	Self-aligning ball bearing Spherical roller bearing CARB bearing	Adapter sleeve	Locating rings 2 per housing	
mm	mm	mm	mm			—					
60	51	120	122	180	1213 EK	H 213	FRB 14/120	2213 EK 22213 EK C 2213 K	H 313	FRB 10/120	
					—	—	—		H 313	FRB 10/120	
	58	140	138	180	1313 EK 21313 EK	H 313	FRB 12.5/140	2313 K 22313 EK	H 2313	FRB 5/140	
						H 313	FRB 12.5/140	—	H 2313	FRB 5/140	
						—	—	—	—	—	
65	56	130	127	175	1215 K	H 215	FRB 15.5/130	2215 EK 22215 EK C 2215 K	H 315	FRB 12.5/130	
					—	—	—		H 315 E	FRB 12.5/130	
	65	160	158	200	1315 K 21315 EK	H 315	FRB 14/160	2315 K 22315 EK C 2315 K	H 2315	FRB 5/160	
						H 315	FRB 14/160		H 2315	FRB 5/160	
						—	—	—	H 2315	FRB 5/160	
70	58	140	138	205	1216 K	H 216	FRB 16/140	2216 EK 22216 EK C 2216 K	H 316	FRB 12.5/140	
					—	—	—		H 316	FRB 12.5/140	
	68	170	163	205	1316 K 21316 EK	H 316	FRB 14.5/170	2316 K 22316 EK C 2316 K	H 2316	FRB 5/170	
						H 316	FRB 14.5/170		H 2316	FRB 5/170	
						—	—	—	H 2316	FRB 5/170	
75	61	150	143	210	1217 K	H 217	FRB 16.5/150	2217 K 22217 EK C 2217 K	H 317	FRB 12.5/150	
					—	—	—		H 317	FRB 12.5/150	
	70	180	178	220	1317 K 21317 EK	H 317	FRB 14.5/180	2317 K 22317 EK C 2317 K	H 2317	FRB 5/180	
						H 317	FRB 14.5/180		H 2317	FRB 5/180	
						—	—	—	H 2317	FRB 5/180	

**SNL plummer block housings
for bearings on adapter sleeve**
d_a 80 – 115 mm

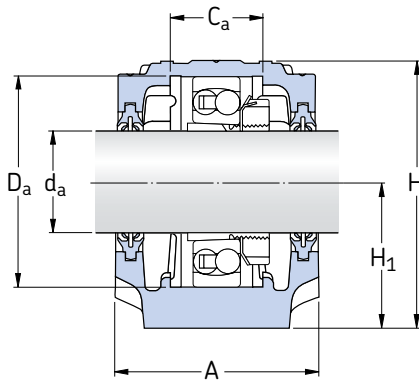

Four-lip seals
L design

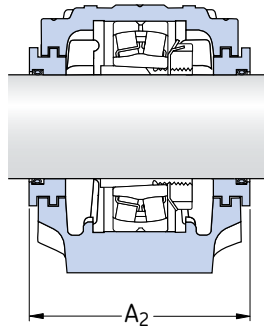

Labyrinth seals
S design

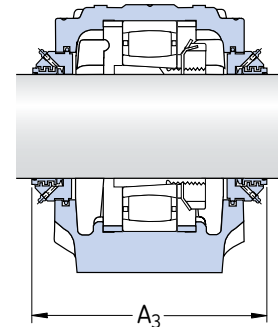

Taconite seals
ND design

Shaft d _a	Housing Dimensions										Mass kg	Designations Housing complete with two seals	Components Housing only	Seals	End cover
	A	A ₁	H	H ₁	H ₂	J	L	N	N ₁	G					
mm	mm														
80	140	100	194	100	35	290	345	28	22	20	12,5	SNL 518 TL	SNL 518-615	TSN 518 L	ASNH 518-615
												SNL 518 TA	SNL 518-615	TSN 518 A	ASNH 518-615
												SNL 518 TS	SNL 518-615	TSN 518 S	ASNH 518-615
												SNL 518 TND	SNL 518-615	TSN 518 ND	ASNH 518-615
85	145	100	212	112	35	290	345	28	22	20	13,7	SNL 519 TL	SNL 519-616	TSN 519 L	ASNH 519-616
												SNL 519 TA	SNL 519-616	TSN 519 A	ASNH 519-616
												SNL 519 TS	SNL 519-616	TSN 519 S	ASNH 519-616
												SNL 519 TND	SNL 519-616	TSN 519 ND	ASNH 519-616
	175	120	242	125	45	350	410	32	26	24	22,0	SNL 619 TG	SNL 522-619	TSN 619 G	ASNH 522-619
												SNL 619 TA	SNL 522-619	TSN 619 A	ASNH 522-619
												SNL 619 TS	SNL 522-619	TSN 619 S	ASNH 522-619
												SNL 619 TND	SNL 522-619	TSN 619 ND	ASNH 522-619
90	160	110	218	112	40	320	380	32	26	24	17,6	SNL 520 TL	SNL 520-617	TSN 520 L	ASNH 520-617
												SNL 520 TA	SNL 520-617	TSN 520 A	ASNH 520-617
												SNL 520 TS	SNL 520-617	TSN 520 S	ASNH 520-617
												SNL 520 TND	SNL 520-617	TSN 520 ND	ASNH 520-617
	185	120	271	140	45	350	410	32	26	24	26,2	SNL 620 TG	SNL 524-620	TSN 620 G	ASNH 524-620
												SNL 620 TA	SNL 524-620	TSN 620 A	ASNH 524-620
												SNL 620 TS	SNL 524-620	TSN 620 S	ASNH 524-620
												SNL 620 TND	SNL 524-620	TSN 620 ND	ASNH 524-620
100	175	120	242	125	45	350	410	32	26	24	22,0	SNL 522 TL	SNL 522-619	TSN 522 L	ASNH 522-619
												SNL 522 TA	SNL 522-619	TSN 522 A	ASNH 522-619
												SNL 522 TS	SNL 522-619	TSN 522 S	ASNH 522-619
												SNL 522 TND	SNL 522-619	TSN 522 ND	ASNH 522-619
110	185	120	271	140	45	350	410	32	26	24	26,2	SNL 524 TG	SNL 524-620	TSN 524 G	ASNH 524-620
												SNL 524 TA	SNL 524-620	TSN 524 A	ASNH 524-620
												SNL 524 TS	SNL 524-620	TSN 524 S	ASNH 524-620
												SNL 524 TND	SNL 524-620	TSN 524 ND	ASNH 524-620
115	190	130	290	150	50	380	445	35	28	24	33,0	SNL 526 TG	SNL 526	TSN 526 G	ASNH 526
												SNL 526 TA	SNL 526	TSN 526 A	ASNH 526
												SNL 526 TS	SNL 526	TSN 526 S	ASNH 526
												SNL 526 TND	SNL 526	TSN 526 ND	ASNH 526

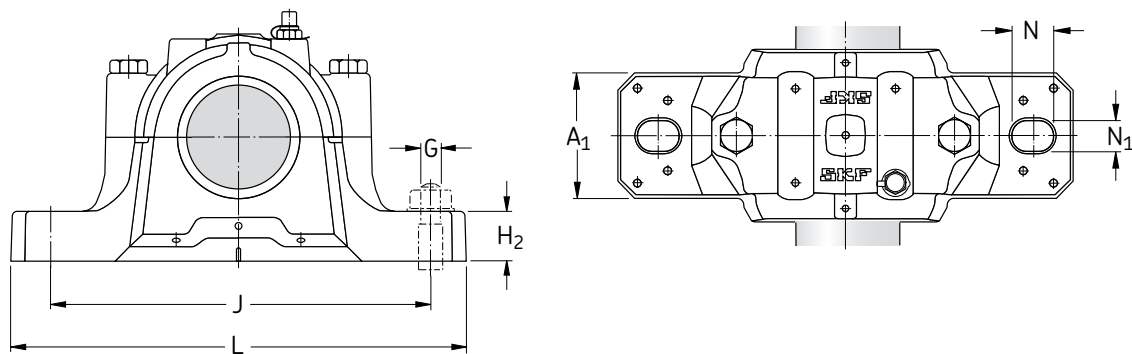

Shaft d_a	Bearing seating		Width across seal		Appropriate bearings and associated components					
	C_a	D_a	A_2	A_3	Self-aligning ball bearing	Adapter sleeve	Locating rings 2 per housing	Self-aligning ball bearing Spherical roller bearing CARB bearing	Adapter sleeve	Locating rings 2 per housing
mm	mm	mm	mm	mm	—					
80	65	160	158	225	1218 K	H 218	FRB 17.5/160	2218 K	H 318	FRB 12.5/160
					22218 EK	H 318	FRB 12.5/160	23218 CCK/W33 C 2218 K	H 2318 H 318 E	FRB 6.25/160 FRB 12.5/160
85	68	170	163	220	1219 K	H 219	FRB 18/170	2219 K	H 319	FRB 12.5/170
					—	—	—	22219 EK	H 319	FRB 12.5/170
80	200	191	235	1319 K	H 319	FRB 17.5/200	2319 K	H 2319	FRB 6.5/200	
				21319 EK	H 319	FRB 17.5/200	22319 EK	H 2319	FRB 6.5/200	
90	70	180	178	230	1220 K	H 220	FRB 18/180	2220 K	H 320	FRB 12/180
					22220 EK	H 320	FRB 12/180	23220 CCK/W33 C 2220 K	H 2320 H 320 E	FRB 4.85/180 FRB 12/180
86	215	199	240	1320 K	H 320	FRB 19.5/215	2320 K	H 2320	FRB 6.5/215	
				21320 EK	H 320	FRB 19.5/215	22320 EK C 2320 K	H 2320 H 2320	FRB 6.5/215 FRB 6.5/215	
100	80	200	191	250	1222 K	H 222	FRB 21/200	2222 K	H 322	FRB 13.5/200
					22222 EK	H 322	FRB 13.5/200	23222 CCK/W33 C 2222 K	H 2322 H 322 E	FRB 5.1/200 FRB 13.5/200
110	86	215	199	260	1224 K	H 3024	FRB 22/215	—	—	—
					22224 EK	H 3124	FRB 14/215	23224 CCK/W33 C 3224 K	H 2324 H 2324 L	FRB 5/215 FRB 5/215
115	90	230	208	265	—	—	—	—	—	—
					22226 EK	H 3126	FRB 13/230	23226 CCK/W33 C 2226 K	H 2326 H 3126 L	FRB 5/230 FRB 13/230

**SNL plummer block housings
for bearings on adapter sleeve
d_a 125 – 140 mm**

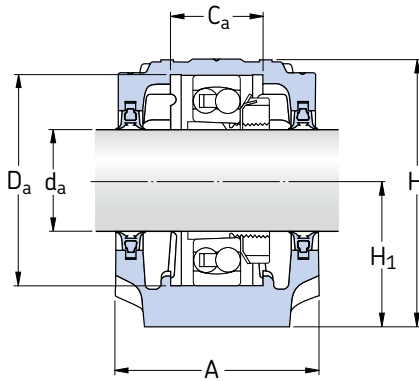

Double-lip seals
G design

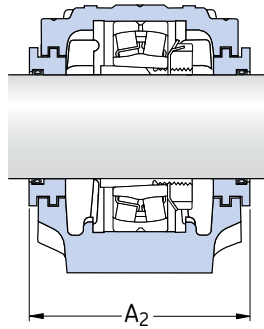

Labyrinth seals
S design

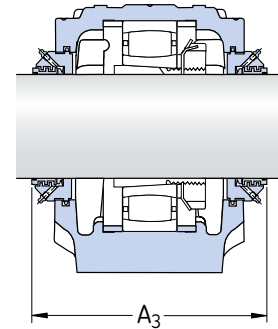

Taconite seals
ND design

Shaft d _a	Housing Dimensions										Mass kg	Designations Housing complete with two seals	Components		End cover
	A	A ₁	H	H ₁	H ₂	J	L	N	N ₁	G			Housing only	Seals	
mm	mm										kg	–			
125	205	150	302	150	50	420	500	42	35	30	40,0	SNL 528 TG	SNL 528	TSN 528 G	ASNH 528
												SNL 528 TA	SNL 528	TSN 528 A	ASNH 528
												SNL 528 TS	SNL 528	TSN 528 S	ASNH 528
												SNL 528 TND	SNL 528	TSN 528 ND	ASNH 528
135	220	160	323	160	60	450	530	42	35	30	49,0	SNL 530 TG	SNL 530	TSN 530 G	ASNH 530
												SNL 530 TA	SNL 530	TSN 530 A	ASNH 530
												SNL 530 TS	SNL 530	TSN 530 S	ASNH 530
												SNL 530 TND	SNL 530	TSN 530 ND	ASNH 530
140	235	160	344	170	60	470	550	42	35	30	55,0	SNL 532 TG	SNL 532	TSN 532 G	ASNH 532
												SNL 532 TA	SNL 532	TSN 532 A	ASNH 532
												SNL 532 TS	SNL 532	TSN 532 S	ASNH 532
												SNL 532 TND	SNL 532	TSN 532 ND	ASNH 532

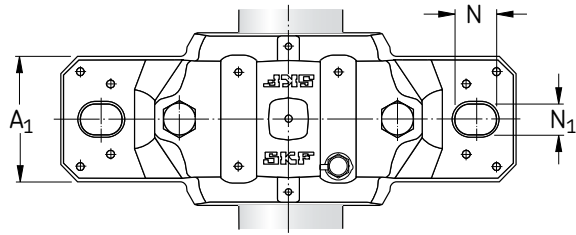
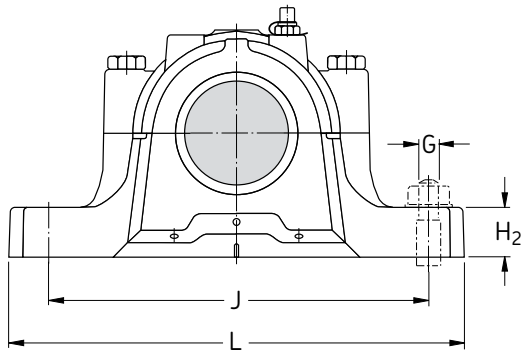

Shaft d_a	Bearing seating		Width across seal		Appropriate bearings and associated components						
	C_a	D_a	A_2	A_3	Spherical roller bearing	Adapter sleeve	Locating rings 2 per housing	Spherical roller bearing CARB bearing	Adapter sleeve	Locating rings 2 per housing	
mm	mm	mm	mm	mm	—						
125	98	250	223	285	22228 CCK/W33	H 3128	FRB 15/250	23228 CCK/W33 C 2228 K	H 2328 H 3128 L	FRB 5/250 FRB 15/250	
135	106	270	241	295	22230 CCK/W33	H 3130	FRB 16.5/270	23230 CCK/W33 C 2230 K	H 2330 H 3130 L	FRB 5/270 FRB 16.5/270	
140	114	290	254	315	22232 CCK/W33	H 3132	FRB 17/290	23232 CCK/W33 C 3232 K	H 2332 H 2332 L	FRB 5/290 FRB 5/290	

**SNL plummer block housings
for bearings with cylindrical bore
d_a 25 – 40 mm**

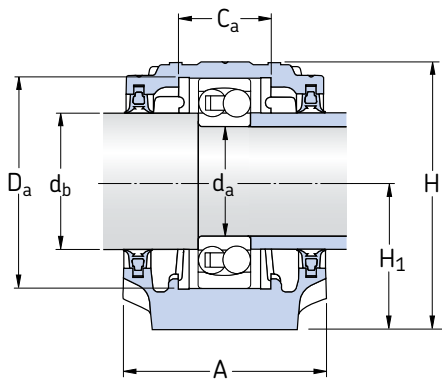

Double-lip seals
G design

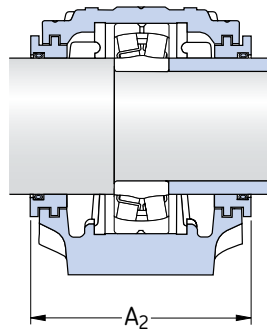

Labyrinth seals
S design

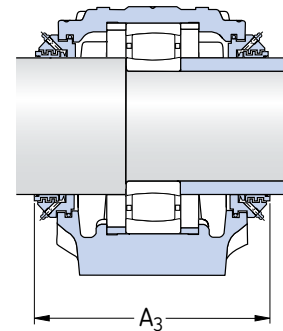

Taconite seals
ND design

Shaft d _a	Housing Dimensions										Mass kg	Designations Housing complete with two seals	Components Housing only	Seals	End cover
	A	A ₁	H	H ₁	H ₂	J	L	N	N ₁	G					
mm	mm										kg	–			
25	67	46	74	40	19	130	165	20	15	12	1,40	SNL 205 TG SNL 205 TS SNL 205 TND	SNL 205 SNL 205 SNL 205	TSN 205 G TSN 205 S TSN 205 ND	ASNH 506-605 ASNH 506-605 ASNH 506-605
	77	52	89	50	22	150	185	20	15	12	1,90	SNL 305 TG SNL 305 TA SNL 305 TS SNL 305 TND	SNL 206-305 SNL 206-305 SNL 206-305 SNL 206-305	TSN 305 G TSN 305 A TSN 305 S TSN 305 ND	ASNH 507-606 ASNH 507-606 ASNH 507-606 ASNH 507-606
30	77	52	89	50	22	150	185	20	15	12	1,90	SNL 206 TG SNL 206 TA SNL 206 TS SNL 206 TND	SNL 206-305 SNL 206-305 SNL 206-305 SNL 206-305	TSN 206 G TSN 206 A TSN 206 S TSN 206 ND	ASNH 507-606 ASNH 507-606 ASNH 507-606 ASNH 507-606
	82	52	93	50	22	150	185	20	15	12	2,20	SNL 306 TG SNL 306 TA SNL 306 TS SNL 306 TND	SNL 507-606 SNL 507-606 SNL 507-606 SNL 507-606	TSN 306 G TSN 306 A TSN 306 S TSN 306 ND	ASNH 507-606 ASNH 507-606 ASNH 507-606 ASNH 507-606
35	82	52	93	50	22	150	185	20	15	12	2,10	SNL 207 TG SNL 207 TA SNL 207 TS SNL 207 TND	SNL 207 SNL 207 SNL 207 SNL 207	TSN 207 G TSN 207 A TSN 207 S TSN 207 ND	ASNH 509 ASNH 509 ASNH 509 ASNH 509
	85	60	108	60	25	170	205	20	15	12	2,75	SNL 307 TG SNL 307 TA SNL 307 TS SNL 307 TND	SNL 208-307 SNL 208-307 SNL 208-307 SNL 208-307	TSN 307 G TSN 307 A TSN 307 S TSN 307 ND	ASNH 510-608 ASNH 510-608 ASNH 510-608 ASNH 510-608
40	85	60	108	60	25	170	205	20	15	12	2,75	SNL 208 TG SNL 208 TA SNL 208 TS SNL 208 TND	SNL 208-307 SNL 208-307 SNL 208-307 SNL 208-307	TSN 208 G TSN 208 A TSN 208 S TSN 208 ND	ASNH 510-608 ASNH 510-608 ASNH 510-608 ASNH 510-608
	90	60	113	60	25	170	205	20	15	12	3,20	SNL 308 TG SNL 308 TA SNL 308 TS SNL 308 TND	SNL 510-608 SNL 510-608 SNL 510-608 SNL 510-608	TSN 308 G TSN 308 A TSN 308 S TSN 308 ND	ASNH 510-608 ASNH 510-608 ASNH 510-608 ASNH 510-608

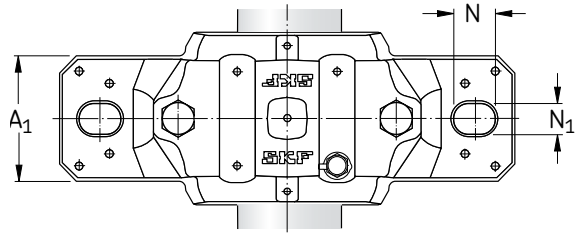
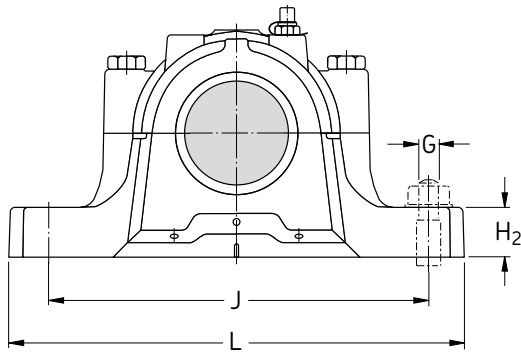

Shaft		Bearing seating		Width across seal		Appropriate bearings and locating rings			
d_a	d_b	C_a	D_a	A_2	A_3	Self-aligning ball bearing Spherical roller bearing	Locating rings 2 per housing	Self-aligning ball bearing Spherical roller bearing CARB bearing	Locating rings 2 per housing
mm		mm		mm		–			
25	30	25	52	90	140	1205 E –	FRB 5/52 –	2205 E 22205 E C 2205	FRB 3.5/52 FRB 3.5/52 FRB 3.5/52
	30	32	62	89	140	1305 E 21305 CC	FRB 7.5/62 FRB 7.5/62	2305 – –	FRB 4/62 – –
30	35	32	62	89	150	1206 E –	FRB 8/62 –	2206 E 22206 E C 2206	FRB 6/62 FRB 6/62 FRB 6/62
	35	34	72	94	155	1306 E 21306 CC	FRB 7.5/72 FRB 7.5/72	2306 – –	FRB 3.5/72 – –
35	45	34	72	96	160	1207 E –	FRB 8.5/72 –	2207 E 22207 E C 2207	FRB 5.5/72 FRB 5.5/72 FRB 5.5/72
	45	39	80	99	145	1307 E 21307 CC	FRB 9/80 FRB 9/80	2307 E – –	FRB 4/80 – –
40	50	39	80	99	160	1208 E –	FRB 10.5/80 –	2208 E 22208 E C 2208	FRB 8/80 FRB 8/80 FRB 8/80
	50	41	90	102	167	1308 E 21308 E	FRB 9/90 FRB 9/90	2308 E 22308 E –	FRB 4/90 FRB 4/90 –

**SNL plummer block housings
for bearings with cylindrical bore**
 d_a 45 – 60 mm

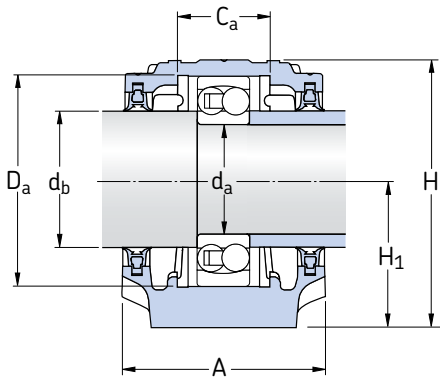

Double-lip seals
G design

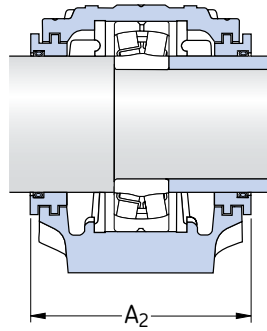

Labyrinth seals
S design

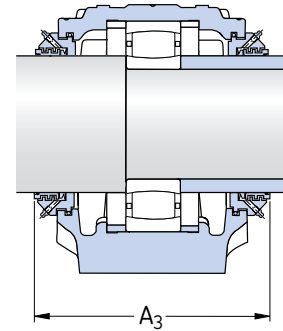

Taconite seals
ND design

d_a	Shaft Housing Dimensions											Mass	Designations Housing complete with two seals	Components Housing only	Seals	End cover
	A	A ₁	H	H ₁	H ₂	J	L	N	N ₁	G						
mm	mm											kg	–			
45	85	60	109	60	25	170	205	20	15	12	2,75	SNL 209 TG SNL 209 TA SNL 209 TS SNL 209 TND	SNL 209 SNL 209 SNL 209 SNL 209	TSN 209 G TSN 209 A TSN 209 S TSN 209 ND	ASNH 511-609 ASNH 511-609 ASNH 511-609 ASNH 511-609	
	95	70	128	70	28	210	255	24	18	16	4,40	SNL 309 TG SNL 309 TA SNL 309 TS SNL 309 TND	SNL 511-609 SNL 511-609 SNL 511-609 SNL 511-609	TSN 309 G TSN 309 A TSN 309 S TSN 309 ND	ASNH 511-609 ASNH 511-609 ASNH 511-609 ASNH 511-609	
50	90	60	113	60	25	170	205	20	15	12	3,00	SNL 210 TG SNL 210 TA SNL 210 TS SNL 210 TND	SNL 210 SNL 210 SNL 210 SNL 210	TSN 210 G TSN 210 A TSN 210 S TSN 210 ND	ASNH 512-610 ASNH 512-610 ASNH 512-610 ASNH 512-610	
	105	70	134	70	30	210	255	24	18	16	5,10	SNL 310 TG SNL 310 TA SNL 310 TS SNL 310 TND	SNL 512-610 SNL 512-610 SNL 512-610 SNL 512-610	TSN 310 G TSN 310 A TSN 310 S TSN 310 ND	ASNH 512-610 ASNH 512-610 ASNH 512-610 ASNH 512-610	
55	95	70	128	70	28	210	255	24	18	16	4,20	SNL 211 TG SNL 211 TA SNL 211 TS SNL 211 TND	SNL 211 SNL 211 SNL 211 SNL 211	TSN 211 G TSN 211 A TSN 211 S TSN 211 ND	ASNH 513-611 ASNH 513-611 ASNH 513-611 ASNH 513-611	
	110	80	150	80	30	230	275	24	18	16	6,50	SNL 311 TG SNL 311 TA SNL 311 TS SNL 311 TND	SNL 513-611 SNL 513-611 SNL 513-611 SNL 513-611	TSN 311 G TSN 311 A TSN 311 S TSN 311 ND	ASNH 513-611 ASNH 513-611 ASNH 513-611 ASNH 513-611	
60	105	70	134	70	30	210	255	24	18	16	4,75	SNL 212 TG SNL 212 TA SNL 212 TS SNL 212 TND	SNL 212 SNL 212 SNL 212 SNL 212	TSN 212 G TSN 212 A TSN 212 S TSN 212 ND	ASNH 515-612 ASNH 515-612 ASNH 515-612 ASNH 515-612	
	115	80	156	80	30	230	280	24	18	16	7,00	SNL 312 TG SNL 312 TA SNL 312 TS SNL 312 TND	SNL 515-612 SNL 515-612 SNL 515-612 SNL 515-612	TSN 312 G TSN 312 A TSN 312 S TSN 312 ND	ASNH 515-612 ASNH 515-612 ASNH 515-612 ASNH 515-612	

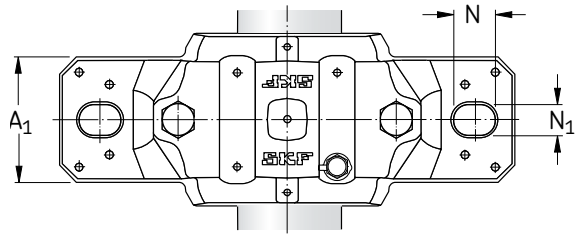
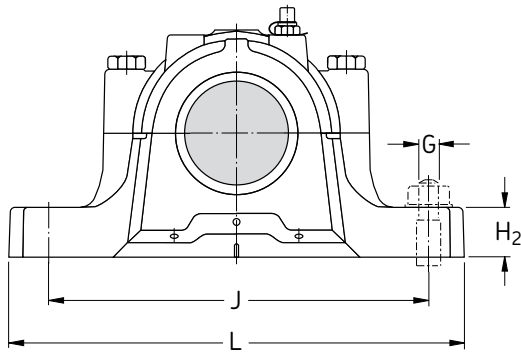

Shaft		Bearing seating		Width across seal		Appropriate bearings and locating rings			
d_a	d_b	C_a	D_a	A_2	A_3	Self-aligning ball bearing Spherical roller bearing	Locating rings 2 per housing	Self-aligning ball bearing Spherical roller bearing CARB bearing	Locating rings 2 per housing
mm		mm		mm		—			
45	55	30	85	97	160	1209 E —	FRB 5.5/85 —	2209 E 22209 E C 2209	FRB 3.5/85 FRB 3.5/85 FRB 3.5/85
	55	44	100	107	172	1309 E 21309 E	FRB 9.5/100 FRB 9.5/100	2309 E 22309 E —	FRB 4/100 FRB 4/100 —
50	60	41	90	102	165	1210 E —	FRB 10.5/90 —	2210 E 22210 E C 2210	FRB 9/90 FRB 9/90 FRB 9/90
	60	48	110	117	180	1310 E 21310 E	FRB 10.5/110 FRB 10.5/110	2310 22310 E —	FRB 4/110 FRB 4/110 —
55	65	44	100	107	170	1211 E —	FRB 11.5/100 —	2211 E 22211 E C 2211	FRB 9.5/100 FRB 9.5/100 FRB 9.5/100
	65	51	120	122	185	1311 E 21311 E	FRB 11/120 FRB 11/120	2311 22311 E —	FRB 4/120 FRB 4/120 —
60	70	48	110	117	185	1212 E —	FRB 13/110 —	2212 E 22212 E C 2212	FRB 10/110 FRB 10/110 FRB 10/110
	70	56	130	127	197	1312 21312 E	FRB 12.5/130 FRB 12.5/130	2312 22312 E —	FRB 5/130 FRB 5/130 —

**SNL plummer block housings
for bearings with cylindrical bore
d_a 65 – 80 mm**

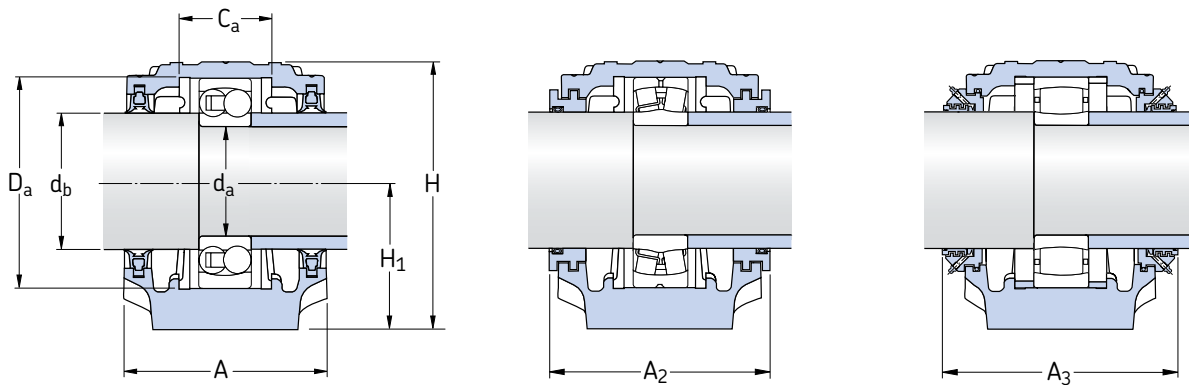

Double-lip seals
G design

Labyrinth seals
S design

Taconite seals
ND design

Shaft d _a	Housing Dimensions										Mass kg	Designations Housing complete with two seals	Components Housing only	Seals	End cover
	A	A ₁	H	H ₁	H ₂	J	L	N	N ₁	G					
mm	mm										kg	–			
65	110	80	149	80	30	230	275	24	18	16	6,10	SNL 213 TG SNL 213 TA SNL 213 TS SNL 213 TND	SNL 213 SNL 213 SNL 213 SNL 213	TSN 213 G TSN 213 A TSN 213 S TSN 213 ND	ASNH 516-613 ASNH 516-613 ASNH 516-613 ASNH 516-613
	120	90	177	95	32	260	315	28	22	20	9,50	SNL 313 TG SNL 313 TA SNL 313 TS SNL 313 TND	SNL 516-613 SNL 516-613 SNL 516-613 SNL 516-613	TSN 313 G TSN 313 A TSN 313 S TSN 313 ND	ASNH 516-613 ASNH 516-613 ASNH 516-613 ASNH 516-613
70	125	90	183	95	32	260	320	28	22	20	10,0	SNL 314 TG SNL 314 TA SNL 314 TS SNL 314 TND	SNL 517 SNL 517 SNL 517 SNL 517	TSN 314 G TSN 314 A TSN 314 S TSN 314 ND	ASNH 517 ASNH 517 ASNH 517 ASNH 517
75	115	80	155	80	30	230	280	24	18	16	6,60	SNL 215 TG SNL 215 TA SNL 215 TS SNL 215 TND	SNL 215 SNL 215 SNL 215 SNL 215	TSN 215 G TSN 215 A TSN 215 S TSN 215 ND	ASNH 518-615 ASNH 518-615 ASNH 518-615 ASNH 518-615
	140	100	194	100	35	290	345	28	22	20	12,5	SNL 315 TG SNL 315 TA SNL 315 TS SNL 315 TND	SNL 518-615 SNL 518-615 SNL 518-615 SNL 518-615	TSN 315 G TSN 315 A TSN 315 S TSN 315 ND	ASNH 518-615 ASNH 518-615 ASNH 518-615 ASNH 518-615
80	120	90	177	95	32	260	315	28	22	20	9,00	SNL 216 TG SNL 216 TA SNL 216 TS SNL 216 TND	SNL 216 SNL 216 SNL 216 SNL 216	TSN 216 G TSN 216 A TSN 216 S TSN 216 ND	ASNH 216 ASNH 216 ASNH 216 ASNH 216
	145	100	212	112	35	290	345	28	22	20	13,7	SNL 316 TG SNL 316 TA SNL 316 TS SNL 316 TND	SNL 519-616 SNL 519-616 SNL 519-616 SNL 519-616	TSN 316 G TSN 316 A TSN 316 S TSN 316 ND	ASNH 519-616 ASNH 519-616 ASNH 519-616 ASNH 519-616

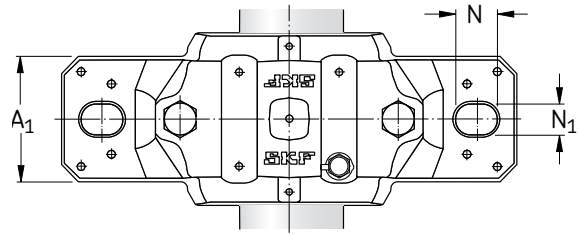
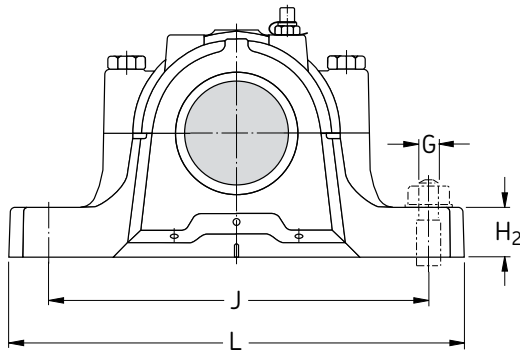

Shaft		Bearing seating		Width across seal		Appropriate bearings and locating rings			
d_a	d_b	C_a	D_a	A_2	A_3	Self-aligning ball bearing Spherical roller bearing	Locating rings 2 per housing	Self-aligning ball bearing Spherical roller bearing CARB bearing	Locating rings 2 per housing
mm		mm		mm		–			
65	75	51	120	128	190	1213 E –	FRB 14/120 –	2213 E 22213 E C 2213	FRB 10/120 FRB 10/120 FRB 10/120
	75	58	140	138	200	1313 E 21313 E	FRB 12.5/140 FRB 12.5/140	2313 22313 E –	FRB 5/140 FRB 5/140 –
70	80	61	150	143	205	1314 21314 E	FRB 13/150 FRB 13/150	2314 22314 E C 2314	FRB 5/150 FRB 5/150 FRB 5/150
	75	85	56	130	133	195	1215 –	FRB 15.5/130 –	2215 E 22215 E C 2215
85		65	160	158	220	1315 21315 E	FRB 14/160 FRB 14/160	2315 22315 E C 2315	FRB 5/160 FRB 5/160 FRB 5/160
80	90	58	140	138	200	1216 –	FRB 16/140 –	2216 E 22216 E C 2216	FRB 12.5/140 FRB 12.5/140 FRB 12.5/140
	90	68	170	163	218	1316 21316 E	FRB 14.5/170 FRB 14.5/170	2316 22316 E C 2316	FRB 5/170 FRB 5/170 FRB 5/170

**SNL plummer block housings
for bearings with cylindrical bore**
d_a 85 – 120 mm

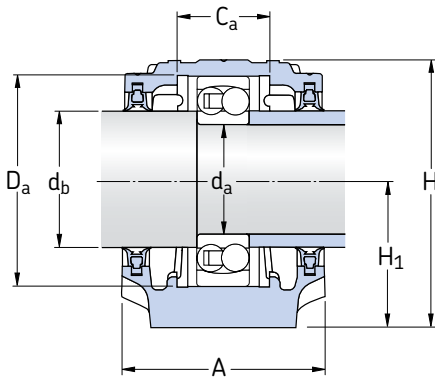

Double-lip seals
G design

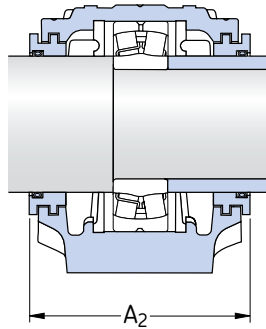

Labyrinth seals
S design

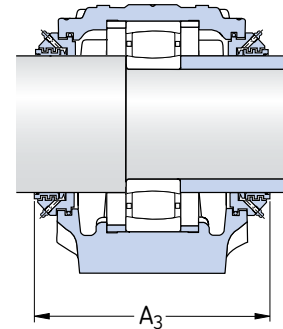

Taconite seals
ND design

Shaft d _a	Housing Dimensions										Mass kg	Designations Housing complete with two seals	Components Housing only	Seals	End cover
	A	A ₁	H	H ₁	H ₂	J	L	N	N ₁	G					
mm	mm										kg	–			
85	125	90	183	95	32	260	320	28	22	20	9,50	SNL 217 TG SNL 217 TA SNL 217 TS SNL 217 TND	SNL 217 SNL 217 SNL 217 SNL 217	TSN 217 G TSN 217 A TSN 217 S TSN 217 ND	ASNH 217 ASNH 217 ASNH 217 ASNH 217
	160	110	218	112	40	320	380	32	26	24	17,6	SNL 317 TG SNL 317 TA SNL 317 TS SNL 317 TND	SNL 520-617 SNL 520-617 SNL 520-617 SNL 520-617	TSN 317 G TSN 317 A TSN 317 S TSN 317 ND	ASNH 520-617 ASNH 520-617 ASNH 520-617 ASNH 520-617
90	140	100	194	100	35	290	345	28	22	20	11,8	SNL 218 TG SNL 218 TA SNL 218 TS SNL 218 TND	SNL 218 SNL 218 SNL 218 SNL 218	TSN 218 G TSN 218 A TSN 218 S TSN 218 ND	ASNH 218 ASNH 218 ASNH 218 ASNH 218
95	175	120	242	125	45	350	410	32	26	24	22,0	SNL 319 TA SNL 319 TS SNL 319 TND	SNL 522-619 SNL 522-619 SNL 522-619	TSN 319 A TSN 319 S TSN 319 ND	ASNH 522-619 ASNH 522-619 ASNH 522-619
100	160	110	218	112	40	320	380	32	26	24	17,6	SNL 220 TG SNL 220 TA SNL 220 TS SNL 220 TND	SNL 520-617 SNL 520-617 SNL 520-617 SNL 520-617	TSN 220 G TSN 220 A TSN 220 S TSN 220 ND	ASNH 520-617 ASNH 520-617 ASNH 520-617 ASNH 520-617
	185	120	271	140	45	350	410	32	26	24	26,2	SNL 320 TA SNL 320 TS SNL 320 TND	SNL 524-620 SNL 524-620 SNL 524-620	TSN 320 A TSN 320 S TSN 320 ND	ASNH 524-620 ASNH 524-620 ASNH 524-620
110	175	120	242	125	45	350	410	32	26	24	22,0	SNL 222 TG SNL 222 TA SNL 222 TS SNL 222 TND	SNL 522-619 SNL 522-619 SNL 522-619 SNL 522-619	TSN 222 G TSN 222 A TSN 222 S TSN 222 ND	ASNH 522-619 ASNH 522-619 ASNH 522-619 ASNH 522-619
120	185	120	271	140	45	350	410	32	26	24	26,2	SNL 224 TG SNL 224 TA SNL 224 TS SNL 224 TND	SNL 524-620 SNL 524-620 SNL 524-620 SNL 524-620	TSN 224 G TSN 224 A TSN 224 S TSN 224 ND	ASNH 524-620 ASNH 524-620 ASNH 524-620 ASNH 524-620

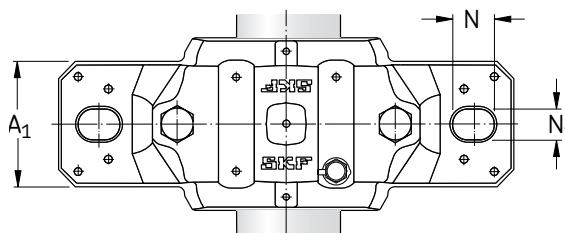
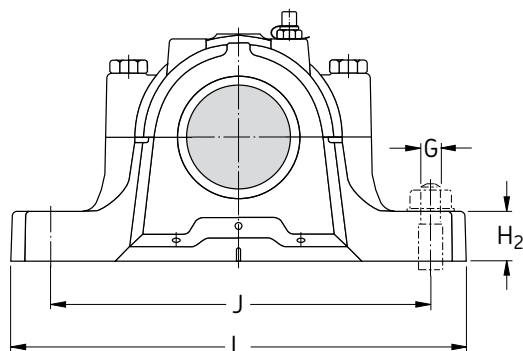

Shaft		Bearing seating		Width across seal		Appropriate bearings and locating rings			
d_a	d_b	C_a	D_a	A_2	A_3	Self-aligning ball bearing Spherical roller bearing	Locating rings 2 per housing	Self-aligning ball bearing Spherical roller bearing CARB bearing	Locating rings 2 per housing
mm		mm		mm		–			
85	95	61	150	143	205	1217 –	FRB 16.5/150 –	2217 22217 E C 2217	FRB 12.5/150 FRB 12.5/150 FRB 12.5/150
	95	70	180	178	238	1317 21317 E	FRB 14.5/180 FRB 14.5/180	2317 22317 E C 2317	FRB 5/180 FRB 5/180 FRB 5/180
90	100	65	160	158	220	1218 22218 E	FRB 17.5/160 FRB 12.5/160	2218 23218 CC/W33 C 2218	FRB 12.5/160 FRB 6.25/160 FRB 12.5/160
95	110	80	200	191	253	1319 21319 E	FRB 17.5/200 FRB 17.5/200	2319 22319 E –	FRB 6.5/200 FRB 6.5/200 –
100	115	70	180	178	245	1220 22220 E	FRB 18/180 FRB 12/180	2220 23220 CC/W33 C 2220	FRB 12/180 FRB 4.85/180 FRB 12/180
	115	86	215	199	260	1320 21320 E	FRB 19.5/215 FRB 19.5/215	2320 22320 E C 2320	FRB 6.5/215 FRB 6.5/215 FRB 6.5/215
110	125	80	200	191	255	1222 22222 E	FRB 21/200 FRB 13.5/200	2222 23222 CC/W33 C 2222	FRB 13.5/200 FRB 5.1/200 FRB 13.5/200
120	135	86	215	199	270	1224 22224 E	FRB 22/215 FRB 14/215	– 23224 CC/W33 C 3224	– FRB 5/215 FRB 5/215

**SNL plummer block housings
for bearings with cylindrical bore
 d_a 130 – 160 mm**

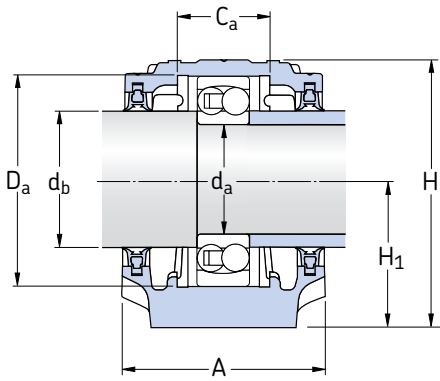

Double-lip seals
G design

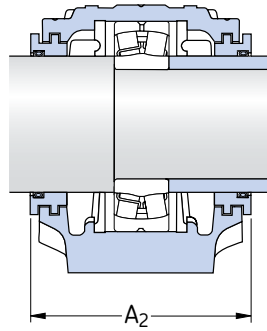

Labyrinth seals
S design

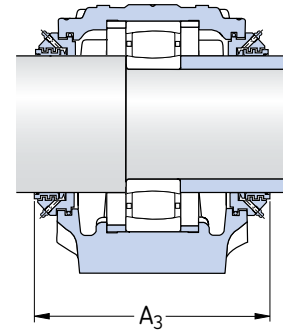

Taconite seals
ND design

Shaft d_a	Housing Dimensions											Mass kg	Designations Housing complete with two seals	Components Housing only	Seals	End cover
	A	A_1	H	H_1	H_2	J	L	N	N_1	G						
mm	mm															
130	190	130	290	150	50	380	445	35	28	24	33,0	SNL 226 TG	SNL 526	TSN 226 G	ASNH 526	
												SNL 226 TA	SNL 526	TSN 226 A	ASNH 526	
												SNL 226 TS	SNL 526	TSN 226 S	ASNH 526	
												SNL 226 TND	SNL 526	TSN 226 ND	ASNH 526	
140	205	150	302	150	50	420	500	42	35	30	40,0	SNL 228 TG	SNL 528	TSN 228 G	ASNH 528	
												SNL 228 TA	SNL 528	TSN 228 A	ASNH 528	
												SNL 228 TS	SNL 528	TSN 228 S	ASNH 528	
												SNL 228 TND	SNL 528	TSN 228 ND	ASNH 528	
150	220	160	323	160	60	450	530	42	35	30	49,0	SNL 230 TG	SNL 530	TSN 230 G	ASNH 530	
												SNL 230 TA	SNL 530	TSN 230 A	ASNH 530	
												SNL 230 TS	SNL 530	TSN 230 S	ASNH 530	
												SNL 230 TND	SNL 530	TSN 230 ND	ASNH 530	
160	235	160	344	170	60	470	550	42	35	30	55,0	SNL 232 TG	SNL 532	TSN 232 G	ASNH 532	
												SNL 232 TA	SNL 532	TSN 232 A	ASNH 532	
												SNL 232 TS	SNL 532	TSN 232 S	ASNH 532	
												SNL 232 TND	SNL 532	TSN 232 ND	ASNH 532	

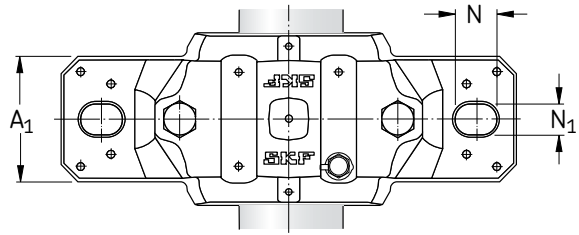
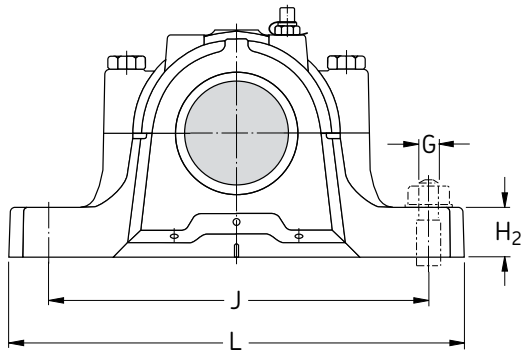

Shaft		Bearing seating		Width across seal		Appropriate bearings and locating rings			
d_a	d_b	C_a	D_a	A_2	A_3	Self-aligning ball bearing Spherical roller bearing	Locating rings 2 per housing	Spherical roller bearing CARB bearing	Locating rings 2 per housing
mm		mm		mm		–			
130	145	90	230	208	275	1226 22226 E	FRB 22/230 FRB 13/230	23226 CC/W33 C 2226	FRB 5/230 FRB 13/230
140	155	98	250	223	290	– 22228 CC/W33	– FRB 15/250	23228 CC/W33 C 2228	FRB 5/250 FRB 15/250
150	165	106	270	241	310	– 22230 CC/W33	– FRB 16.5/270	23230 CC/W33 C 2230	FRB 5/270 FRB 16.5/270
160	175	114	290	254	325	– 22232 CC/W33	– FRB 17/290	23232 CC/W33 C 3232	FRB 5/290 FRB 5/290

Large SNL plummer block housings

The large SNL plummer block housings (→ **fig. 1**) incorporate all the wide experience gained by SKF with the smaller SNL housings (→ **page 1033**) and extend the range to bigger shafts. These housings represent a further development of the SD housings.

Large SNL plummer block housings are intended to take

- spherical roller bearings in the 230, 231 and 232 series
- CARB toroidal roller bearings in the C 30, C 31 and C 32 series

as standard, but can be used for bearings in the 22, 23 and 40 Dimension Series too. Please contact the SKF application engineering service for further information.

The large SNL housings are designed for bearing arrangement types

- bearing on adapter sleeve and smooth shafts with 115 to 500 mm as well as 5 ¹⁵/₁₆ to 19 1/2 inch diameter
- bearing on stepped shafts and cylindrical seatings with 130 to 530 mm diameter.

Seals

- Labyrinth seals
- Taconite heavy-duty seals
- Oil seals

Lubrication

- Grease lubrication
- Oil lubrication

Materials

- Grey cast iron
- Spheroidal graphite cast iron

Further information

Further information can be found in the product brochure “SNL 30 and SNL 31 plummer block housings solve the housing problems” or the “SKF Interactive Engineering Catalogue” on CD-ROM or online at www.skf.com.

Fig. 1

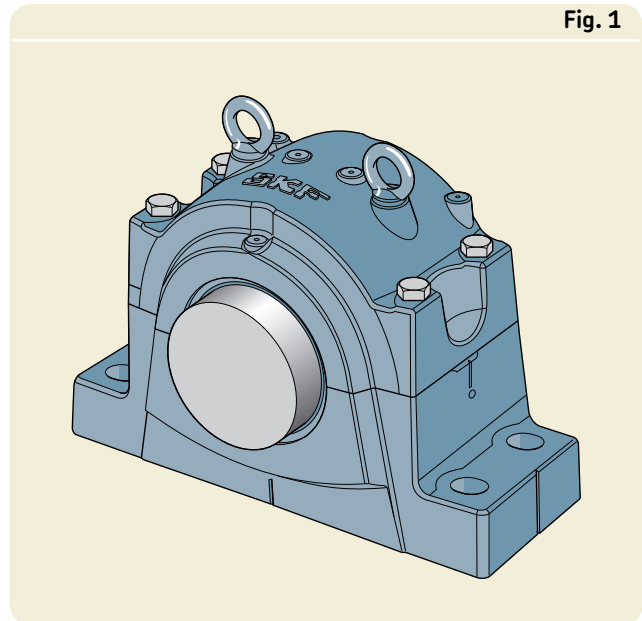

SONL plummer block housings

SONL plummer block housings (→ **fig. 2**) are specifically designed for oil lubrication and are particularly suitable for bearing arrangements, where speed and operating temperatures are high. These housings represent a further development of the earlier SOFN housings with which they are dimensionally interchangeable and which they replace.

The split SONL plummer block housings are intended for

- spherical roller bearings in the 222 series
- CARB toroidal roller bearings in the C 22 series.

They are designed for bearing arrangement types

- bearing on adapter sleeve and smooth shafts with 75 to 220 mm diameter
- bearing on stepped or smooth shafts and cylindrical seatings with 85 to 240 mm diameter.

The earlier SOFN plummer block housings for bearings in the 23 Dimension Series are not replaced by SONL housings but will still be available on request for replacement purposes.

Seals

- Labyrinth seals

Lubrication

- Oil lubrication with pick-up ring
- Circulating oil lubrication

Materials

- Grey cast iron
- Spheroidal graphite cast iron

Further information

Further information can be found in the product brochure “SONL plummer block housings – designed for oil lubrication” or the “SKF Interactive Engineering Catalogue” on CD-ROM or online at www.skf.com.

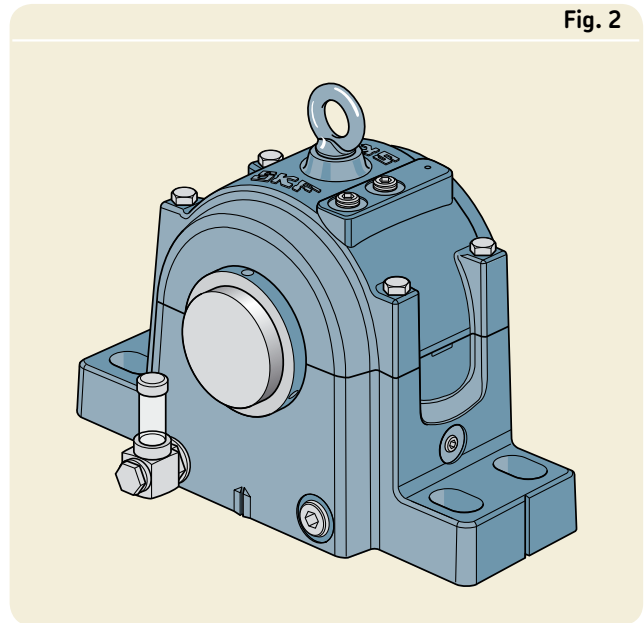

Other bearing housings

SDG plummer block housings

SDG plummer block housings (→ **fig. 3**) have been developed for large bearing arrangements. These split housings can be used for

- spherical roller bearings and CARB bearings in several dimension series.

The housings are designed for bearing arrangement types

- bearing on adapter sleeve and smooth shafts with 125 to 530 mm diameter
- bearing on adapter sleeve and stepped shafts with cylindrical seatings with 125 to 530 mm diameter
- bearing on withdrawal sleeve and stepped shafts with cylindrical seatings with 135 to 600 mm diameter
- bearing on stepped shafts and cylindrical seatings with 140 to 710 mm diameter.

Seals

- Felt seals
- Felt seals with additional V-ring
- Labyrinth seals with inner felt seal

Lubrication

- Grease lubrication

Materials

- Grey cast iron
- Spheroidal graphite cast iron
- Cast steel

Further information

Further information can be found in the SKF catalogue “Bearing housings” or the “SKF Interactive Engineering Catalogue” on CD-ROM or online at www.skf.com.

Fig. 3

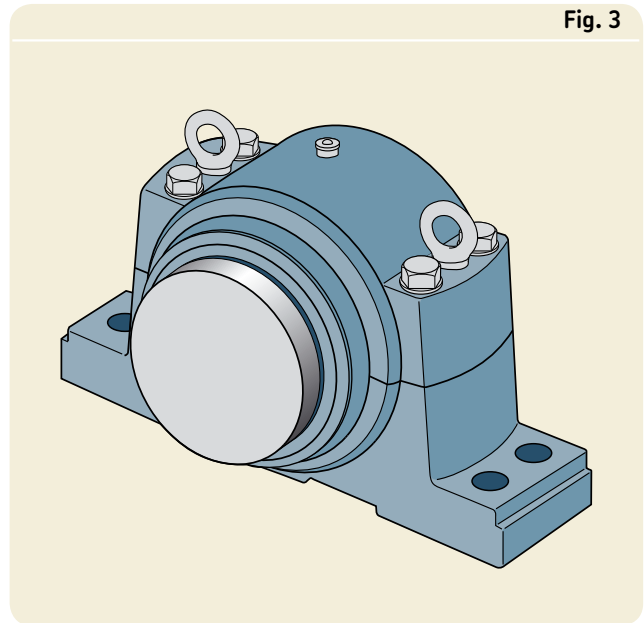

SAF pillow (plummer) block housings

SAF pillow (plummer) block housings (→ **fig. 4**) were specifically designed for shafts with inch dimensions. The split housings can be used for

- self-aligning ball bearings in the 12 and 13 series
- spherical roller bearings in the 222, 223, and 230 series
- CARB bearings in the C 22, C 23 and C 30 series.

The housings are designed for bearing arrangement types

- bearing on adapter sleeve and smooth shafts with $1 \frac{3}{16}$ to $10 \frac{7}{16}$ inch diameter
- bearing on stepped inch shafts and metric cylindrical seatings with 40 to 220 mm diameter.

Seals

- Labyrinth seals
- Labyrinth seals with inner radial shaft seal
- Radial shaft seals
- Taconite heavy-duty seals

Lubrication

- Grease lubrication
- Oil lubrication

Materials

- Grey cast iron
- Spheroidal graphite cast iron
- Cast steel

Further information

Further information can be found in the SKF catalogue “Product Guide” or the “SKF Interactive Engineering Catalogue” on CD-ROM or online at www.skf.com.

Fig. 4

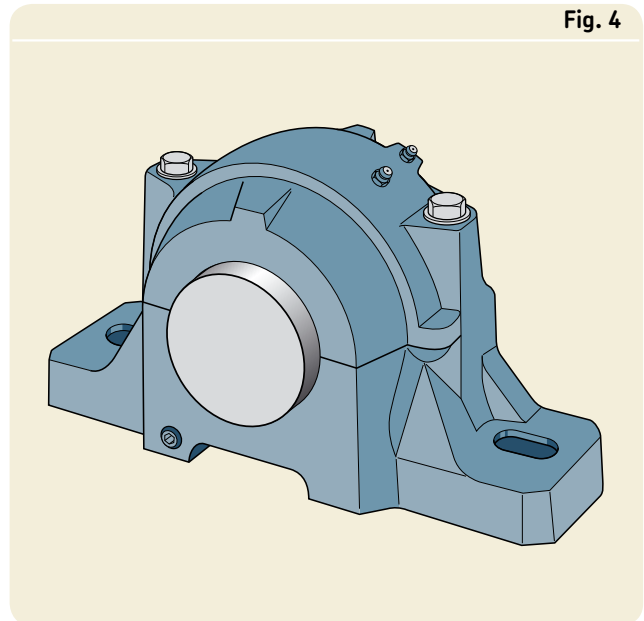

Other bearing housings

SDAF pillow (plummer) block housings

SDAF pillow (plummer) block housings (→ **fig. 5**) were specifically designed for applications with inch shafts where heavy thrust loads and/or shock loads require a housing of exceptionally sturdy construction. The split housings can be used for

- spherical roller bearings in the 222 and 223 series
- CARB bearings in the C 22 and C 23 series.

The housings are designed for bearing arrangement types

- bearing on adapter sleeve and smooth shafts with $2 \frac{15}{16}$ to $7 \frac{15}{16}$ inch diameter
- bearing on stepped inch shafts and metric cylindrical seatings with 85 to 220 mm diameter.

Seals

- Labyrinth seals
- Labyrinth seals with inner radial shaft seal
- Radial shaft seals
- Taconite heavy-duty seals

Lubrication

- Grease lubrication
- Oil lubrication

Materials

- Grey cast iron
- Cast steel

Further information

Further information can be found in the SKF catalogue “Product Guide” or the “SKF Interactive Engineering Catalogue” on CD-ROM or online at www.skf.com.

Fig. 5

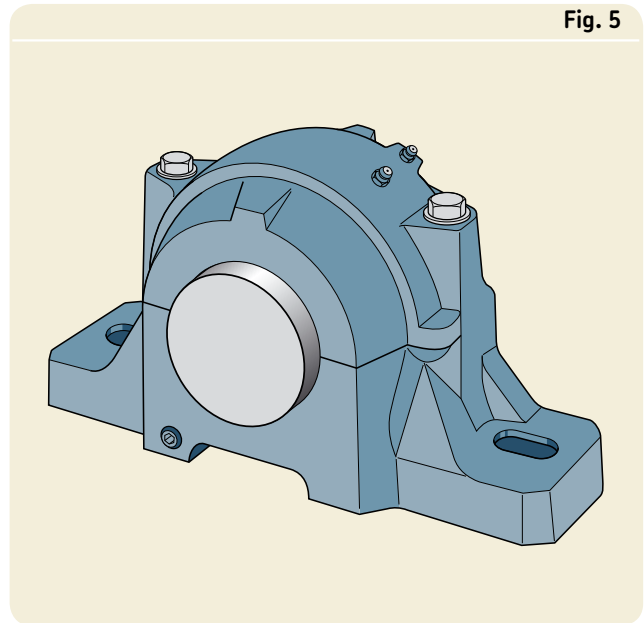

SBD plummer block housings

One-piece SBD plummer block housings (→ **fig. 6**) are able to accommodate heavy loads not only acting towards the support surface, but also in other directions. They can be used for

- spherical roller bearings in the 230, 231, 222 and 232 series
- CARB bearings in the C 30, C 31, C 22 and C 32 series.

The housings are designed for bearing arrangement types

- bearing on adapter sleeve and smooth shafts with 90 to 400 mm diameter
- bearing on adapter sleeve and stepped shafts with cylindrical seatings with 90 to 400 mm diameter
- bearing on stepped shafts and cylindrical seatings with 100 to 420 mm diameter.

Seals

- Labyrinth seals

Lubrication

- Grease lubrication

Materials

- Cast steel
- Grey cast iron
- Spheroidal graphite cast iron

Further information

Further information can be found in the SKF catalogue “Bearing housings” or the “SKF Interactive Engineering Catalogue” on CD-ROM or online at www.skf.com.

Fig. 6

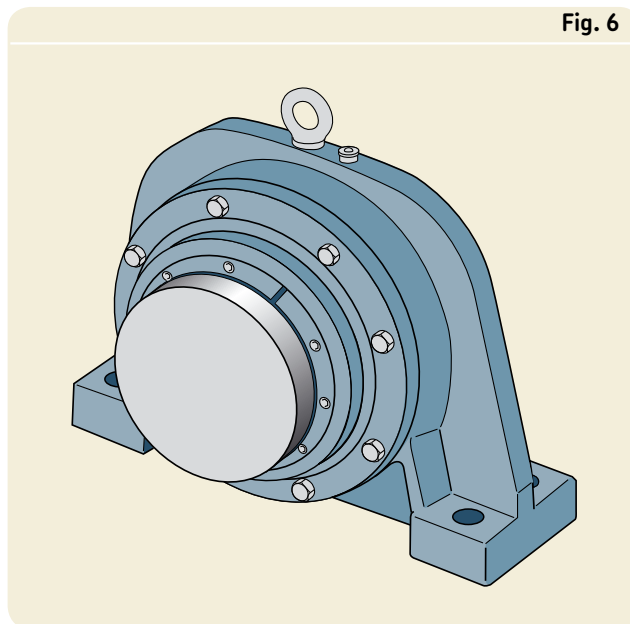

Other bearing housings

TVN plummer block housings

One-piece TVN housings (→ **fig. 7**) were originally designed for use on light rail-bound trucks but may be used instead of plummer block housings. The one-piece design is stiffer than a horizontally split design. They accommodate

- self-aligning ball bearings in the 12 and 13 series
- spherical roller bearings in the 213 series.

The housings are designed for bearing arrangement type

- bearing on stepped shafts and cylindrical seatings with 20 to 75 mm diameter.

Seals

- Felt seals

Lubrication

- Grease lubrication

Material

- Grey cast iron

Further information

Further information can be found in the SKF catalogue “Bearing housings” or the “SKF Interactive Engineering Catalogue” on CD-ROM or online at www.skf.com.

Fig. 7

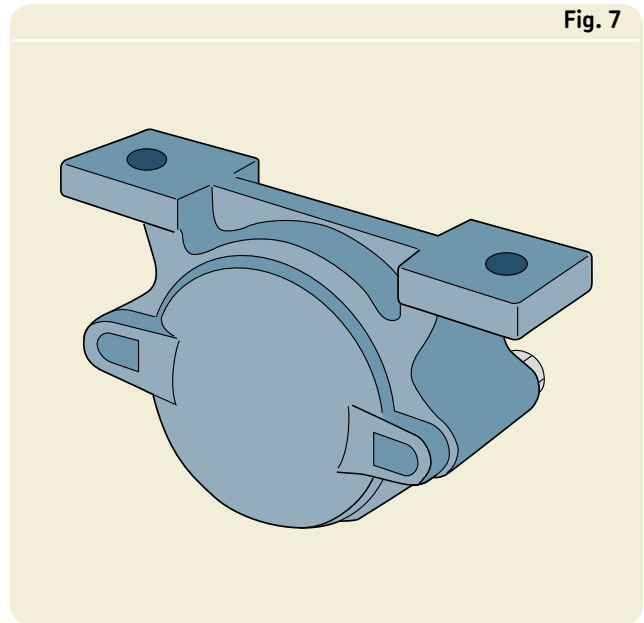

TN plummer block housings

One-piece TN housings (→ **fig. 8**) are normally used for less demanding applications. They accommodate self-aligning ball bearings with extended inner ring in the 112 series for shaft diameters from 20 to 60 mm.

Seals

- Felt seals

Lubrication

- Grease lubrication

Material

- Grey cast iron

Further information

Further information can be found in the SKF catalogue “Bearing housings” or the “SKF Interactive Engineering Catalogue” on CD-ROM or online at www.skf.com.

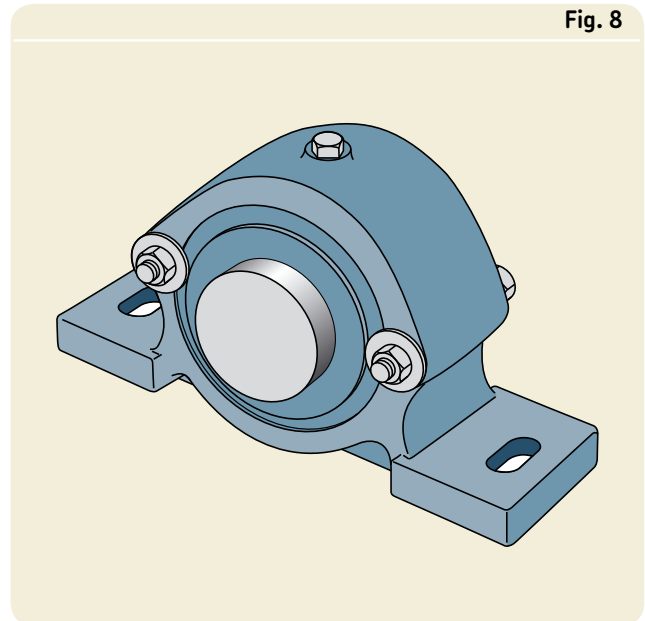

I-1200(00) flanged housings

Flanged housings in the I-1200(00) series (→ **fig. 9**) are normally used for less demanding applications. They accommodate self-aligning ball bearings with extended inner ring in the 112 series for shaft diameters from 20 to 60 mm.

Seals

- Felt seals

Lubrication

- Grease lubrication

Material

- Grey cast iron

Further information

Further information can be found in the SKF catalogue “Bearing housings” or the “SKF Interactive Engineering Catalogue” on CD-ROM or online at www.skf.com.

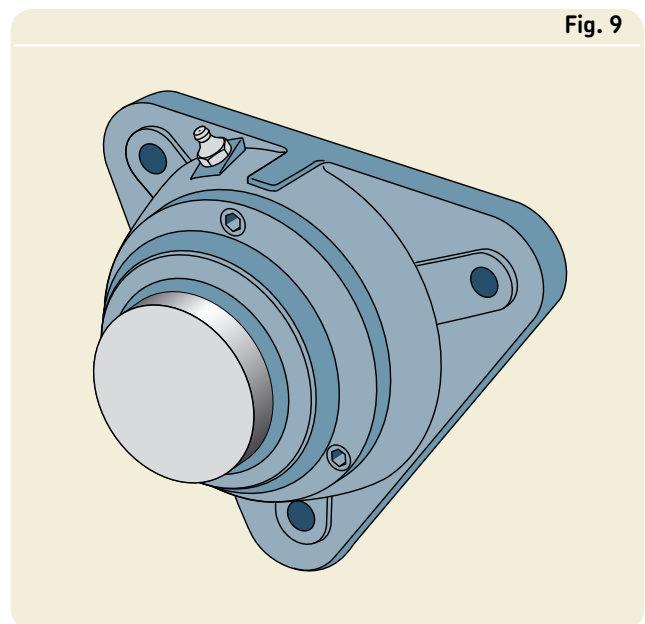

Other bearing housings

7225(00) flanged housings

Flanged housings in the 7225(00) series are produced in two designs depending on size (→ **fig. 10**). The smaller sizes have a triangular form (**a**) and the larger sizes have a square form (**b**). They can be used for

- self-aligning ball bearings in the 12 and 22 series
- spherical roller bearings in the 222 series
- CARB bearings in the C 22 series.

The housings are designed for bearing arrangement type

- bearing on adapter sleeve and smooth shafts with 20 to 100 mm diameter.

Seals

- Felt seals

Lubrication

- Grease lubrication

Material

- Grey cast iron

Further information

Further information can be found in the SKF catalogue “Bearing housings” or the “SKF Interactive Engineering Catalogue” on CD-ROM or online at www.skf.com.

Fig. 10

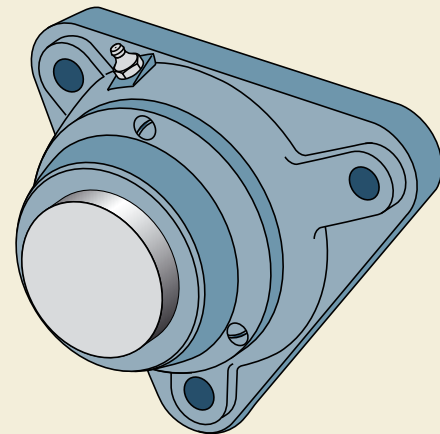

a

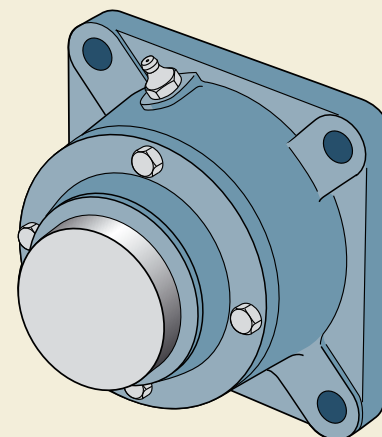

b

THD take-up housings

THD take-up housings (→ **fig. 11**) are specially designed for belt conveyors. They can be used for

- spherical roller bearings in the 230, 231, 232 and 222 series
- CARB bearings in the C 30, C 31, C 32 and C 22 series.

The housings are designed for bearing arrangement type

- bearing on adapter sleeve and smooth shafts with 50 to 400 mm diameter.

Seals

- Labyrinth seals

Lubrication

- Grease lubrication

Materials

- Cast steel
- Grey cast iron
- Spheroidal graphite cast iron

Further information

Further information can be found in the SKF catalogue “Bearing housings” or the “SKF Interactive Engineering Catalogue” on CD-ROM or online at www.skf.com.

Fig. 11

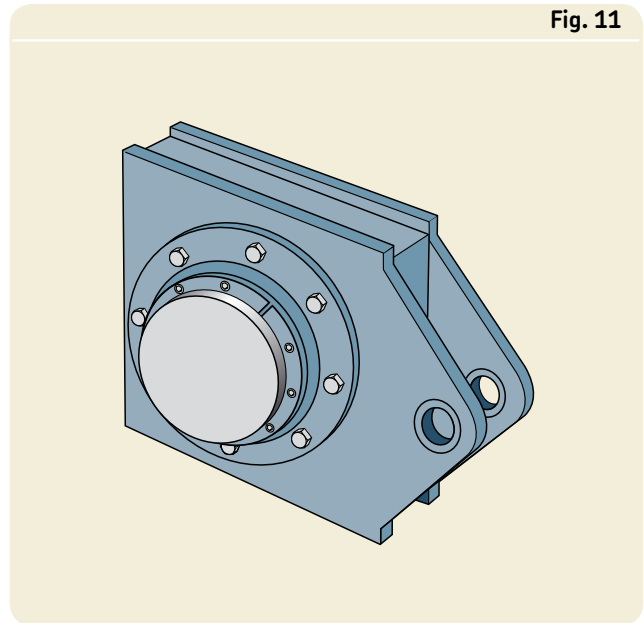



Maintenance and lubrication products

Mechanical tools	1070
Hook and impact spanners	1070
Lock nut spanners and axial lock nut sockets	1070
Bearing fitting tools.....	1070
Jaw pullers.....	1071
Strong back pullers	1071
Internal and blind pullers	1071
Bearing heaters	1072
Induction heaters	1072
Portable induction heater	1072
Hot plate	1073
Heating devices to remove inner rings.....	1073
Gloves.....	1073
Hydraulic tools.....	1074
Hydraulic nuts.....	1074
Hydraulic pumps and oil injectors.....	1075
Hydraulic accessories	1075
Instruments.....	1076
Tachometer	1076
Thermometers	1076
Electronic stethoscope	1076
Oil check monitor.....	1077
Alignment instruments and shims	1077
Lubricants and lubricators	1078
Greases	1078
Grease guns and pumps	1078
Grease meter	1078
SYSTEM 24® single point automatic lubricator	1079
SYSTEM MultiPoint automatic lubricator.....	1079
Oil leveller	1079



Maintenance and lubrication products

SKF develops and markets maintenance tools, lubricants and lubricators to optimize mounting, dismantling and lubrication of bearings. The product assortment includes mechanical tools, heaters, oil injection equipment, instruments, lubricants and lubricators (→ the catalogue “SKF Maintenance and Lubrication Products” or online at www.mapro.skf.com).

Mechanical tools

Mechanical tools are used mainly for mounting and dismantling small and medium-sized bearings. The SKF range comprises tools for the installation and removal of bearings and locking devices. The range also contains bearing handling tools for safe and rapid lifting and positioning of bearings weighing up to 500 kg.

Hook and impact spanners

SKF hook spanners have the exact radius to suit the appropriate lock nut. This enables safe and efficient tightening and minimizes the risk of damage to both the nut and shaft.

Impact spanners are made of spheroidal graphite cast iron and have a special impact face to transmit a maximum torque to the nut. Each spanner can be used with several nut sizes.

Lock nut spanners and axial lock nut sockets

To mount SKF self-aligning ball bearings on adapter sleeves in housings, a special bearing lock nut spanner set TMHN 7 is available. Using these spanners, the appropriate tightening angle is easy to achieve and this enables consistently accurate bearing mounting.

Axial lock nut sockets are especially useful if there is insufficient space around the lock nut. They have drive connections suitable for use with power tools or torque wrenches.

Bearing fitting tools

SKF bearing fitting tools enable small bearings to be cold mounted on a shaft. They can also be used to mount bushings, seals and pulleys. The kits consist of impact rings and sleeves and a dead blow hammer.



Jaw pullers

SKF jaw pullers enable a wide range of bearings to be dismantled. One of the puller series, designated TMMA, which design is unique to SKF, incorporates a spring enabling easy opening and closing of the arms, while a special safety solution helps to prevent dangerous overload. A range of hydraulic spindles and rams are also available for increased puller forces. The SKF jaw puller range contains pullers with withdrawal forces up to 500 kN.

Strong back pullers

SKF strong back pullers are supplied as kits with all necessary accessories to cover the most difficult pulling operations. Strong back pullers consist of either a two or three-piece separable yoke, which when placed behind the bearing makes a “strong back”. The pulling force can be applied using a mechanical spindle, a hydraulic spindle or a hydraulic ram.

Internal and blind pullers

To dismantle a wide range of deep groove ball bearings from blind housing bores quickly and easily, SKF has developed blind housing puller kits. These pullers have hinged arms with specially machined ends so that they fit into the bearing raceway(s), enabling the bearing to be extracted from the housing.

Puller kits for removing bearings from housings, using an internal pull, consist of a number of adjustable collets that can be expanded to fit on the rear side of the bearing bore. A slide hammer arrangement allows large forces to be applied to the bearing in order to remove it.



Bearing heaters

A fast and very efficient way to heat a bearing for mounting is to use an induction heater. These heaters, which only heat metallic components, control bearing temperature safely and accurately, to minimize the risk of bearing damage caused by excessive heat.

Induction heaters

SKF pioneered the use of induction heaters for bearing applications. SKF TIH induction heaters cover a wide range of bearing types and sizes. The smaller heaters are recommended for bearings weighing up to 80 kg while the largest floor model can be used for bearings up to 700 kg.

Large heaters are also suitable for heating smaller bearings, as a power reduction feature is incorporated. SKF induction heaters can be controlled by means of time or temperature. In addition, they feature a bearing heating mode to help prevent damage to bearings through overheating. At the end of each heating cycle, the bearings are automatically demagnetized.

Portable induction heater

The portable SKF induction heater heats bearings and other components with a bore diameter up to 100 mm and a maximum weight of 5 kg. It uses a patented method of heating based on high frequency induction for optimized efficiency. This truly portable unit weighs just 4,5 kg and is supplied with a heating clamp, temperature probe, power cable and a carrying case.



Hot plate

The SKF electric hot plate heats small bearings and other machinery components. It is suitable for bearings with an outside diameter up to approximately 170 mm or with a weight up to 4 kg. A lid for retaining the heat also prevents dirt from entering the bearing.

Heating devices to remove inner rings

A range of special heating devices for removing cylindrical roller bearing inner rings from shafts is available from SKF. Aluminium heating rings are designed for dismantling inner rings of small and medium-size cylindrical roller bearings.

Adjustable induction heaters are also available for frequent dismantling of various sizes of cylindrical roller bearing inner rings. Two sizes are available covering raceway diameters from 80 to 170 mm. Non-adjustable induction heaters are designed to suit a particular bearing and application. They are normally used to dismount inner rings of multi-row cylindrical roller bearings.

Gloves

SKF heat resistant gloves are specially designed for the handling of heated bearings and other machine components.

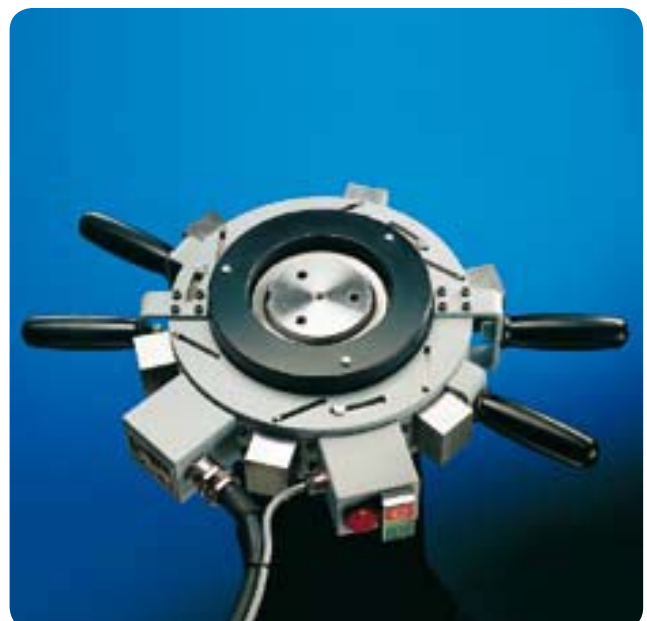

Hydraulic tools

A variety of hydraulic tools is available to mount and dismount bearings in a safe and controlled manner. The SKF oil injection method enables easy working while the SKF Drive-up Method provides accurate results.

Hydraulic nuts

HMV .. E type hydraulic nuts enable mounting and dismounting of bearings with a tapered bore of 50 mm and above. When compared with mechanical methods, they considerably reduce the time and effort needed to install or remove a bearing. SKF HMV .. E nuts are available with metric or imperial threads or with a plain bore.

SKF HMV .. E nuts, when used in conjunction with SKF pumps fitted with a digital pressure gauge and a dial indicator, enable the full advantages of the SKF Drive-up Method to be realized.



Hydraulic pumps and oil injectors

SKF hand-operated hydraulic pumps can develop pressures up to 150 MPa. They can be supplied with a highly accurate pressure gauge, which enables the SKF Drive-up Method to be employed. All pumps are contained in a sturdy carrying case complete with a hose, quick connection coupling, nipple and mounting fluid.

Oil Injectors can supply oil pressures up to 400 MPa. The SKF range comprises single injectors as well as a number of kits, which contain an injector and a selection of the most common accessories such as an adapter block, high-pressure pipes and nipples.

For large bearings and applications requiring a larger volume of oil, several air-driven portable pumps and injectors providing pressures up to 300 MPa are available.

Hydraulic accessories

To facilitate connections between hydraulic tools and most applications, SKF offers a wide range of accessories including pressure gauges, high pressure pipes, connection nipples and mounting and dismantling fluids.



Instruments

To realize maximum bearing life, it is important to determine the operating condition of machinery and their bearings. With the SKF measuring instrument range, critical environmental conditions can be analysed to achieve optimum bearing performance.

Tachometer

Optical measurement is a safe and reliable technique to determine rotational speed. Using non-contact instruments is often essential to meet industrial safety regulations. SKF provides a highly accurate optical tachometer. A range of accessories enables linear and direct contact rotational speeds to be measured.



Thermometers

The temperature of a bearing or bearing housing is a quick and easy indication of the running conditions of the bearing. SKF provides a range of contact and non-contact thermometers from the indispensable ThermoPen up to a highly accurate, advanced dual channel, wide range thermometer. A comprehensive range of temperature probes for a variety of applications is also available.



Electronic stethoscope

The noise of a machine can help indicate troublesome parts such as damaged bearings, valve chatter, tappet noise, piston slap and gear and pump noise. The SKF electronic stethoscope is a hand-held instrument that picks up the noise or vibration from a machine via a probe and helps the user locate the source of the noise.



Oil check monitor

The SKF oil check monitor determines oil condition by analysing the contamination levels and electro-chemical changes in both mineral and synthetic based oils. It was developed originally for engine oils but is suitable for gear and lubrication oils. It can also help to detect water, anti-freeze or metallic particles in an oil sample.

Alignment instruments and shims

SKF has developed laser alignment tools to make the machinery alignment process faster, easier and more reliable. Using the latest laser technology, the SKF shaft alignment tool measures both the parallel and angular alignment of shafts to be connected.

SKF's belt alignment tool aligns the grooves in a pulley rather than the pulley face, facilitating accurate and simultaneous adjustment of belt tension and pulley alignment.

A comprehensive range of pre-cut machinery shims in both metric and inch dimensions is available.



Lubricants and lubricators

The value and importance of using the right lubricant is explained in the section “Lubrication”, starting on **page 229**. The formulation of all SKF bearing greases is based on extensive research, grease performance testing and field experience.

SKF developed many of the internationally accepted bearing-related grease testing parameters. For correct lubricant application, a range of lubrication equipment is available from SKF.

Greases

SKF offers a range of high quality lubricating greases to suit many bearing applications and conditions. The greases have been developed specifically to meet the needs of rolling bearings and their application conditions.

A guide to select the most suitable SKF grease can be found in **table 2** on **pages 246** and **247**. The table also contains the important properties.

Grease guns and pumps

The SKF range also includes grease guns, manual and air-driven grease pumps and grease filler pumps. Grease filler pumps are used to fill grease guns and grease packers from standard SKF grease drums.

Grease meter

The SKF grease meter can accurately measure the volume of grease pumped into a bearing. A wide range of accessories is available.



SYSTEM 24® single point automatic lubricator

SYSTEM 24 is a single point automatic lubricator, pre-filled with SKF grease or oil. Compared with traditional manual re-lubrication techniques, SYSTEM 24 provides a more accurate control of the quantity of lubricant supplied. It can be set to continuously supply the correct amount of quality lubricant over a given time period, up to a maximum of one year.

SYSTEM MultiPoint automatic lubricator

SKF SYSTEM MultiPoint is a microprocessor controlled automatic lubricator. Grease can be supplied to up to eight points, using standard SKF grease cartridges. The cartridges make sure that only clean fresh grease is used. SYSTEM MultiPoint lubricator has been tested and approved for use with all SKF bearing greases.

Oil leveller

The SKF oil levellers are designed for automatic adjustment of the optimal oil level in oil bath lubricated applications. They effectively overcome the problem of adjusting the correct oil level during operation or due to leakage rather than just during standstill.





Other SKF products

Other ball bearings.....	1083
Large deep groove ball bearings with filling slots.....	1083
Fixed section ball bearings.....	1083
Multi-row ball bearings.....	1084
Large-size angular contact thrust ball bearings.....	1084
Bearings for inline skates and skateboards	1084
Other roller bearings	1085
Needle roller and cage assemblies	1085
Drawn cup needle roller bearings.....	1085
Drawn cup universal joint bearings	1085
Needle roller bearings.....	1086
Alignment needle roller bearings	1086
Needle roller thrust bearings.....	1086
Combined needle roller bearings.....	1087
Track runner bearings	1088
Double row cylindrical roller bearings.....	1089
Multi-row cylindrical roller bearings	1089
Double row taper roller bearings.....	1089
Four-row taper roller bearings.....	1090
Taper roller thrust bearings	1090
Split cylindrical roller bearings	1091
Split spherical roller bearings	1091
Split CARB® toroidal roller bearings	1091
Backing bearings for cluster mills.....	1092
Indexing roller units for continuous furnaces of sintering plants	1092
Crossed taper roller bearings.....	1092
Slewing bearings.....	1093
Single row slewing ball bearings	1093
Single row slewing roller bearings	1093
Double row slewing bearings.....	1094
Triple row slewing bearings	1094
Other slewing bearings	1094
Specials for special applications	1095
Products for railway vehicles	1095
Products for automotive applications.....	1096
Vehicle replacement parts	1097
High-precision bearings for machine tools.....	1098
Magnetic bearings.....	1099



Products for the pulp and paper industry	1100
Products for the printing industry	1101
Products for aerospace applications.....	1102
Seals.....	1103
Centralized lubrication systems	1104
SKF system solutions.....	1107
SKF Copperhead.....	1107
BoMo bogie monitoring system.....	1107
SKF WindCon solution for wind turbines.....	1107
SKF Smart Chock Unit.....	1108
SKF ConRo system for continuous casters.....	1108
SKF bearing carrier	1108
Spindle units.....	1109
Linear motion products	1111
Linear guidance systems.....	1111
High efficiency ball screws	1111
High efficiency roller screws	1111
Linear actuators	1112
Positioning systems.....	1112
Plain bearings.....	1113
Spherical plain bearings and rod ends	1113
Bushings	1114
Special solutions.....	1114
Bearing units	1115
Y-bearing units.....	1115
SKF ConCentra ball and roller bearing units	1116
Collar mounted roller bearing units.....	1117
Two-bearing units.....	1117
Support and thrust roller assemblies.....	1117
Hydrostatic shoe bearings	1118
Auto-balancing.....	1118
Fastening systems, rolling elements	1119
Shaft couplings.....	1119
Supergrip bolts.....	1119
Bushings	1120
SKF ConCentra bushings.....	1120
Rolling elements.....	1120

Other ball bearings

Large deep groove ball bearings with filling slots

These are special SKF deep groove ball bearings for heavily loaded bearing arrangements where there are slewing movements, e.g. the support bearing arrangement of converter drives. The bearings may be of the full complement type or they may contain separator rings or spacers to separate the balls.

Additional information can be found in the “SKF Interactive Engineering Catalogue”.

Fixed section ball bearings

Fixed section ball bearings are part of the SKF thin section bearing assortment. As the name suggests, thin section bearings have very thin rings and very low cross section. They are further characterized by low weight, low friction and high stiffness. Fixed section ball bearings are inch dimension bearings that have a constant cross section within a particular series irrespective of the bearing size.

SKF fixed section bearings are available as either open or sealed

- deep groove ball bearings
- angular contact ball bearings
- four-point contact ball bearings

in up to eight different cross sections.

Additional information can be found in the SKF product brochure “Fixed section bearings”.

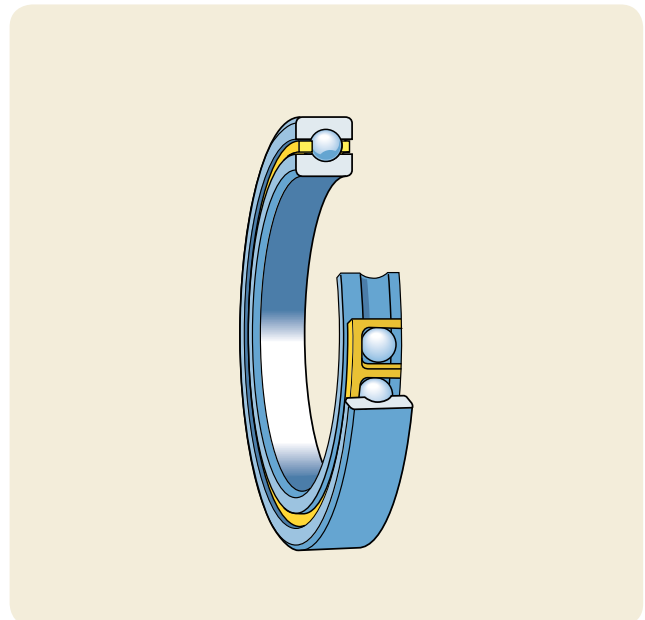
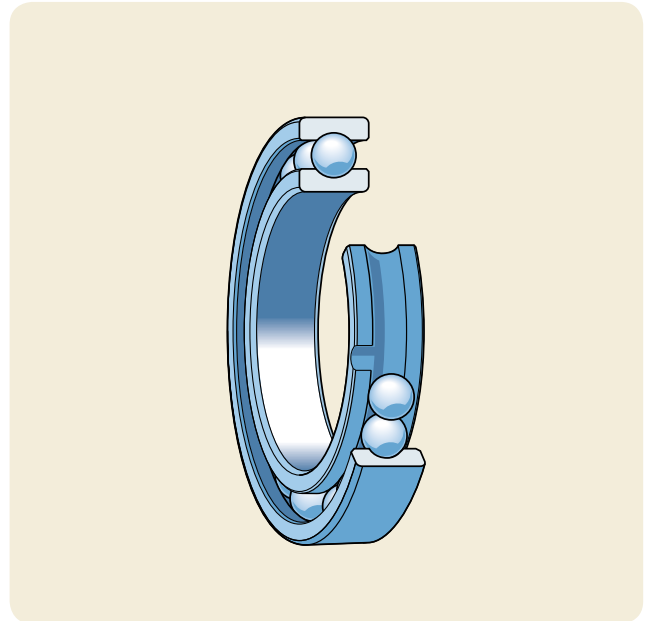

Other SKF products

Multi-row ball bearings

Multi-row ball bearings have several rows of balls held and guided in a machined brass cage. The inner and outer ring raceways have a cylindrical form so that axial displacement of the shaft relative to the housing can be accommodated within the bearing in both directions. A convex sphered outside diameter on the outer ring enables the bearing to compensate for initial misalignment.

Multi-row ball bearings are specially designed to support the axially oscillating doctor rolls of paper machine dryer sections. They are available from SKF in two designs.

Additional information can be found in the “SKF Interactive Engineering Catalogue”.

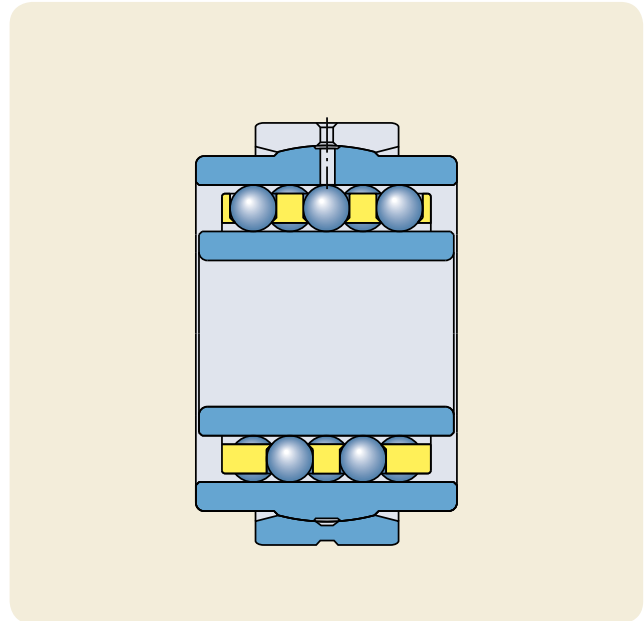

Large-size angular contact thrust ball bearings

Large-size SKF angular contact thrust ball bearings were originally designed to support the rotary tables of drilling rigs but are also suitable for other applications where high load carrying capacity, high axial stiffness and low frictional moment are important. In contrast to conventional thrust ball bearings, angular contact thrust ball bearings can accommodate radial loads in addition to axial loads and are able to operate at high speeds. They are available as single direction or double direction thrust bearings.

Additional information can be found in the “SKF Interactive Engineering Catalogue”.

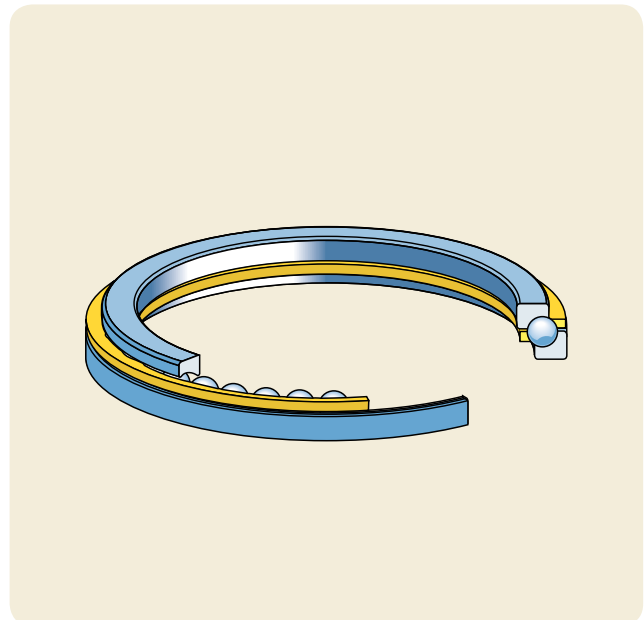

Bearings for inline skates and skateboards

SKF has been involved in skate bearings since the early days of quads (roller skates), skateboards and inline skates. So many bearing executions were designed by SKF, that today there is a full range of state-of-the-art bearings, adapted to each skating style and need.

For more information, please visit www.skfsport.com.

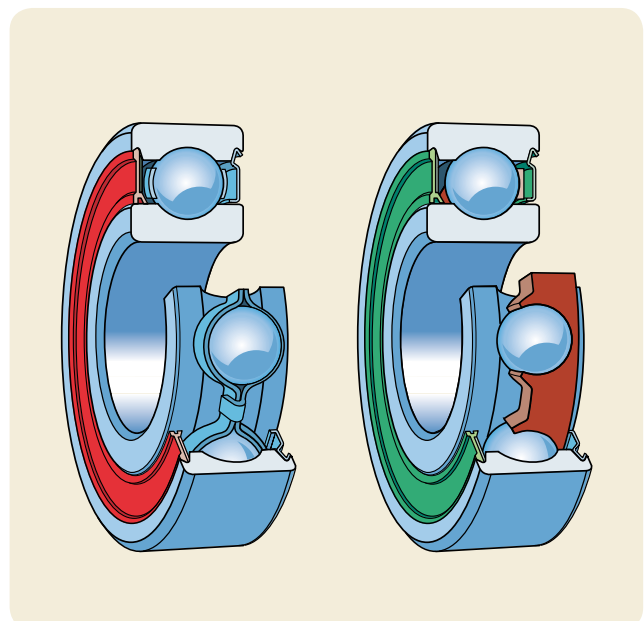

Other roller bearings

Needle roller and cage assemblies

Needle roller and cage assemblies are ready-to-mount, self-contained bearing arrangement components. They enable bearing arrangements having high load carrying capacity and stiffness and require a minimum of radial space if the shaft and housing bore can serve as raceways and have the same hardness and surface finish as bearing rings.

SKF needle roller and cage assemblies are available in single row and double row designs. They are characterized by their simple and rugged design, accurate guidance of the needle rollers in the cage pockets, and good running properties.

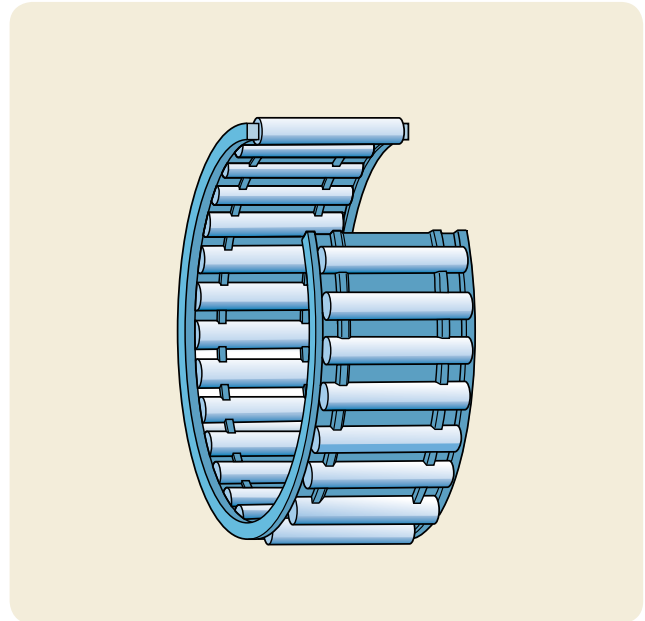

Drawn cup needle roller bearings

Drawn cup needle roller bearings have a deep drawn thin-walled outer ring and are characterized by very low sectional height and high load carrying capacity. They are generally used when the housing bore cannot be used as a raceway. They are used directly on the shaft, but can also be combined with an inner ring.

SKF drawn cup needle roller bearings are available with either an open or closed end; with or without integral seals.

Additional information can be found in the SKF catalogue "Needle roller bearings" or in the "SKF Interactive Engineering Catalogue".

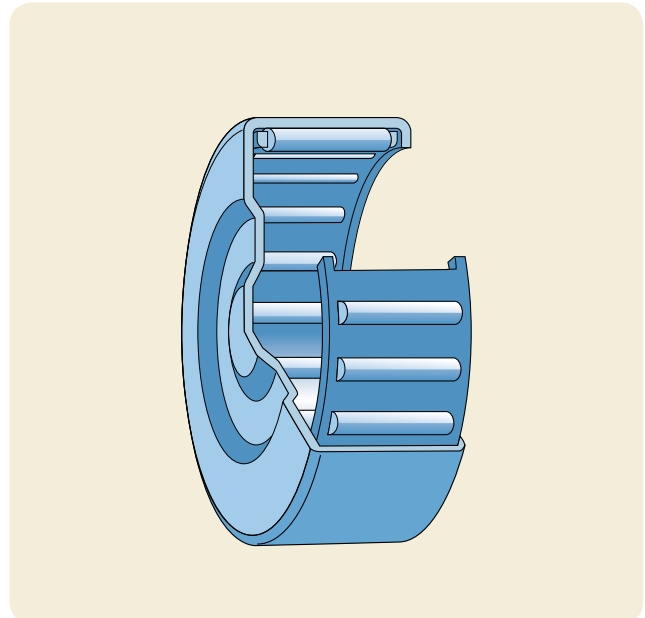

Drawn cup universal joint bearings

Special drawn cup needle roller bearings with a closed end are available for the universal joints of commercial vehicle propeller shafts. The thin-walled, case hardened drawn cup enables the use of relatively large diameter rollers to provide high load carrying capacity while still permitting compact bearing arrangements.

SKF universal joint bearings are available in several designs and sizes in the inside diameter range from 20 to 48 mm.

Further information will be supplied on request.

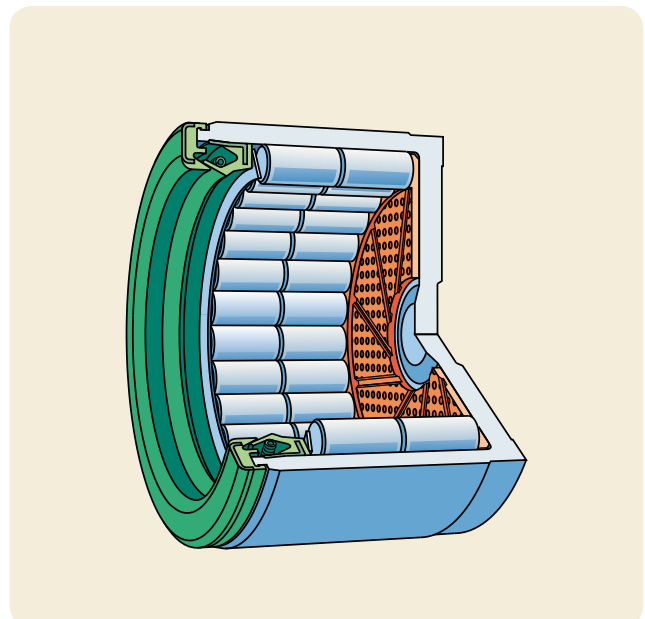

Other SKF products

Needle roller bearings

Needle roller bearings with carbon chromium steel rings have a low sectional height and a very high load carrying capacity for their size. They may be used with or without an inner ring, depending on the application.

SKF needle roller bearings are available in several designs and many sizes. The majority of these are bearings with integral internal outer ring flanges. Also included in the range are bearings without these flanges and sealed bearings.

Alignment needle roller bearings

Alignment needle roller bearings have an outer ring with a convex sphered outside surface. A plastic seating ring with a concave sphered inside surface and encased in a drawn sheet steel sleeve is fitted over the outer ring, thus enabling the bearing to align.

Alignment needle roller bearings are therefore insensitive to initial misalignment of the shaft relative to the housing. SKF alignment needle roller bearings can be supplied with or without an inner ring.

Needle roller thrust bearings

Needle roller thrust bearings can support heavy axial loads, are virtually insensitive to shock loads and provide stiff bearing arrangements, which require a minimum of axial space. They are single direction bearings and can accommodate axial loads acting in one direction.

SKF needle roller thrust bearings are available as needle roller and cage thrust assemblies, which can be combined with washers of various designs. Because of all the possible combinations, all the bearing components can be ordered separately.

Additional information can be found in the SKF catalogue “Needle roller bearings” or in the “SKF Interactive Engineering Catalogue”.

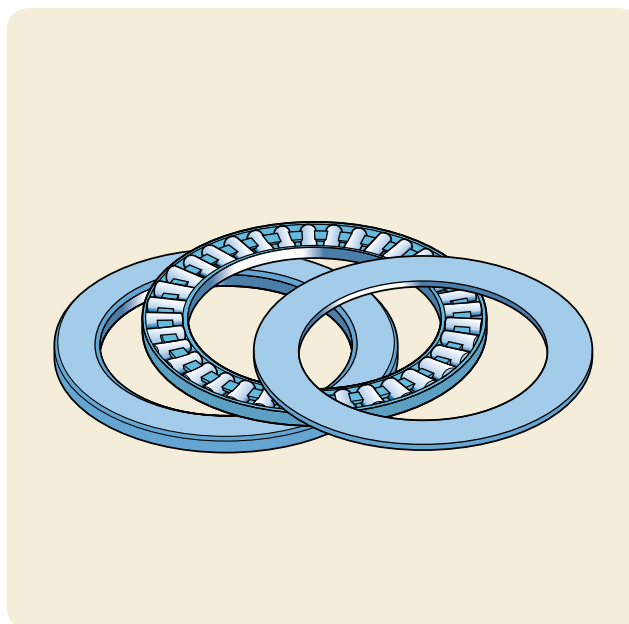
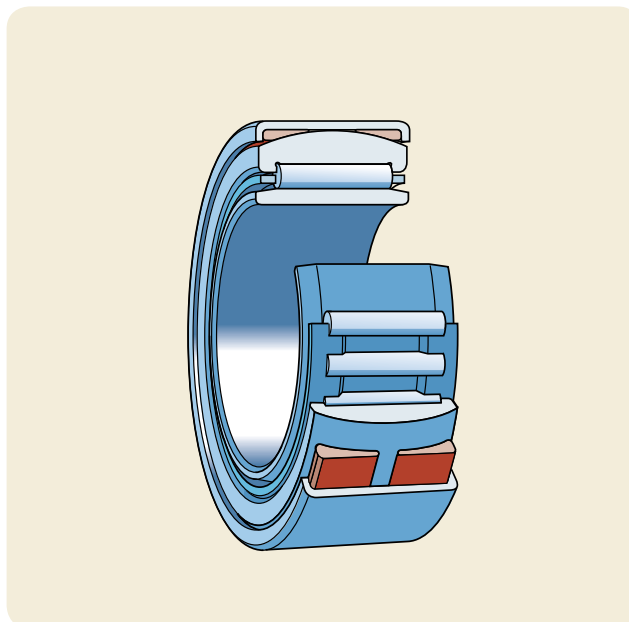
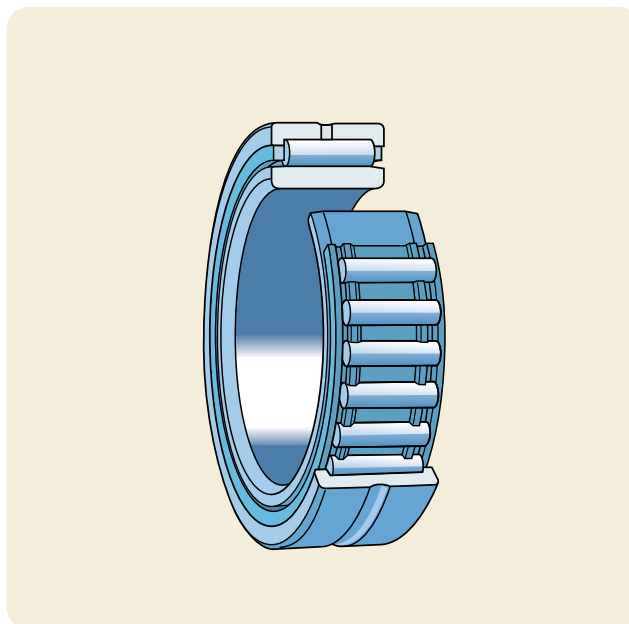

Combined needle roller bearings

Combined needle roller bearings consist of a radial needle roller bearing combined with a thrust bearing and are consequently able to accommodate both radial and axial loads in one or both directions. They provide the means to produce locating bearing arrangements in a minimum of radial space. They are particularly suited for applications where the axial loads are too heavy, speeds too high, or lubrication inadequate for simple thrust washers to be used or where other types of locating bearings occupy too much space.

SKF combined needle roller bearings are available as

- needle roller/angular contact ball bearings
- needle roller/thrust ball bearings
- needle roller/cylindrical roller thrust bearings.

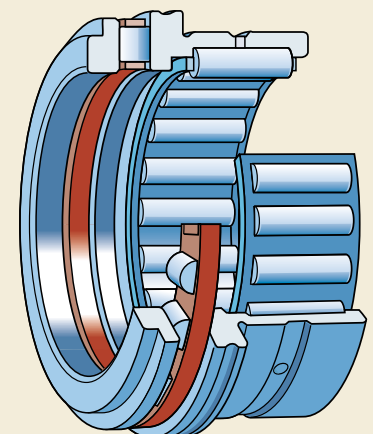
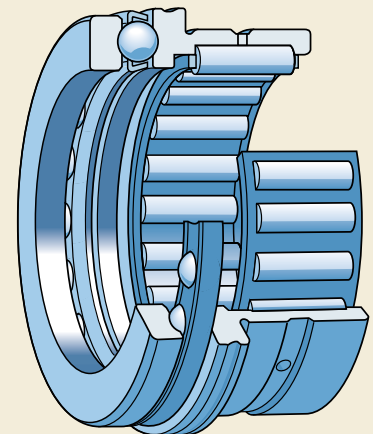
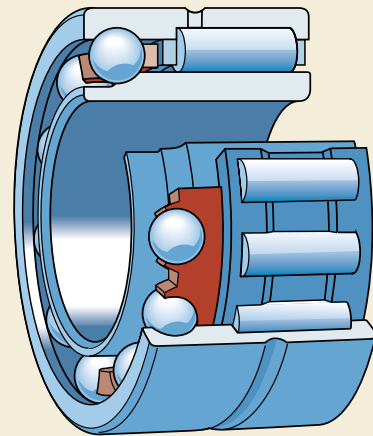

Additional information can be found in the SKF catalogue “Needle roller bearings” or in the “SKF Interactive Engineering Catalogue”.

Other SKF products

Track runner bearings

Track runner bearings are rolling bearings with a particularly thick-walled outer ring that can accommodate heavy loads as well as shock loads. Track runner bearings are ready-to-mount units and used for all types of cam drives, conveyor systems etc.

The SKF standard range includes the cam rollers shown in the sections

- “Deep groove ball bearings”
(→ **page 399**)
- “Angular contact ball bearings”
(→ **page 463**)
- support rollers and cam followers mentioned below.

Support rollers

SKF support rollers are basically needle or cylindrical roller bearings. The outside surface of the outer ring is crowned to reduce edge stresses if the roller runs in a tilted or inclined position. They are available in several designs.

Sealed support rollers are filled with grease and are ready-to-mount and ready-to-use units.

Cam followers

SKF cam followers are essentially needle or cylindrical roller bearings, which have a solid stud instead of the inner ring. The stud is threaded so that the cam follower can be easily attached to appropriate machine components. Cam followers are filled with appropriate grease and are ready-to-mount and ready-to-use units.

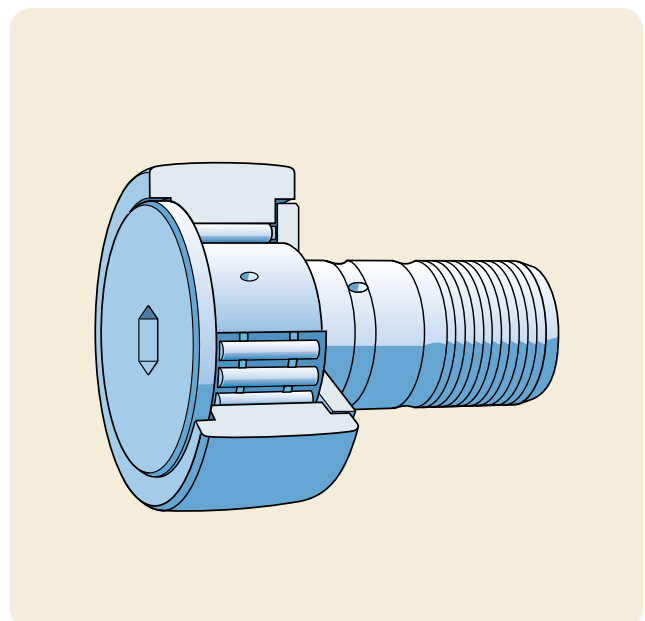
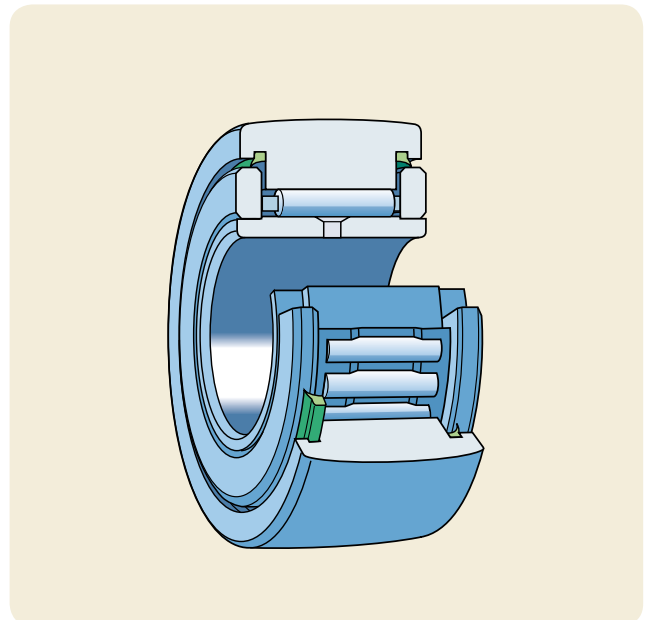
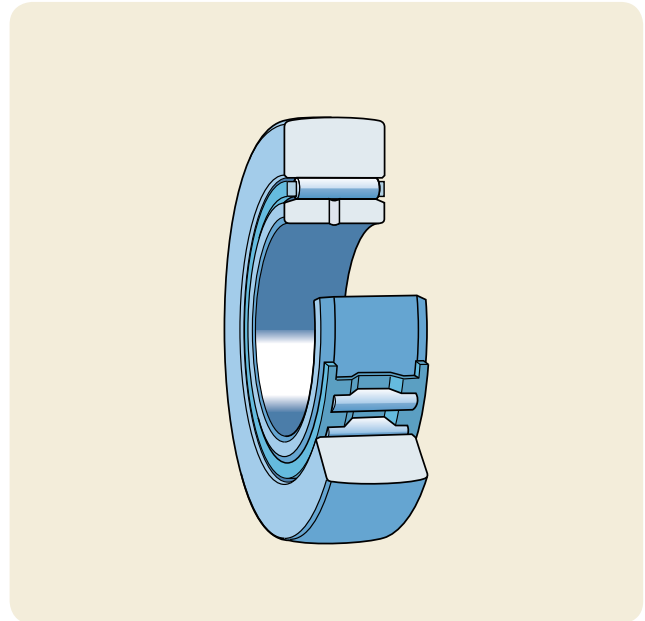

Additional information can be found in the SKF catalogue “Needle roller bearings” or in the “SKF Interactive Engineering Catalogue”.

Double row cylindrical roller bearings

Double row cylindrical roller bearings have a low cross section, high load carrying capacity and high stiffness. They are used primarily in machine tools, rolling mill stands, plastic calenders, grinding mills and also large gearboxes.

SKF double row cylindrical roller bearings are produced with a cylindrical or tapered bore and are available in various designs.

Multi-row cylindrical roller bearings

Four-row and six-row cylindrical roller bearings are used almost exclusively for the roll necks of rolling mill stands, calenders and roller presses. They are of separable design to considerably simplify bearing mounting, maintenance and inspection.

SKF four-row cylindrical roller bearings have a cylindrical bore and some sizes are also available with a tapered bore or as sealed bearings, with a seal on one or both sides of the bearing.

Double row taper roller bearings

Double row taper roller bearings provide a stiff bearing arrangement under heavy load. They can accommodate combined radial and axial loads and locate a shaft axially in both directions with a given axial clearance or preload.

SKF double row taper roller bearings are produced in

- the TDO configuration with a one-piece outer ring and roller sets arranged back-to-back
- the TDI configuration with a one-piece inner ring and roller sets arranged face-to-face.

SKF bearings in the TDI configuration have a cylindrical bore and some sizes are also available with a tapered bore or with seals on both sides of the bearing.

Additional information can be found in the “SKF Interactive Engineering Catalogue”.

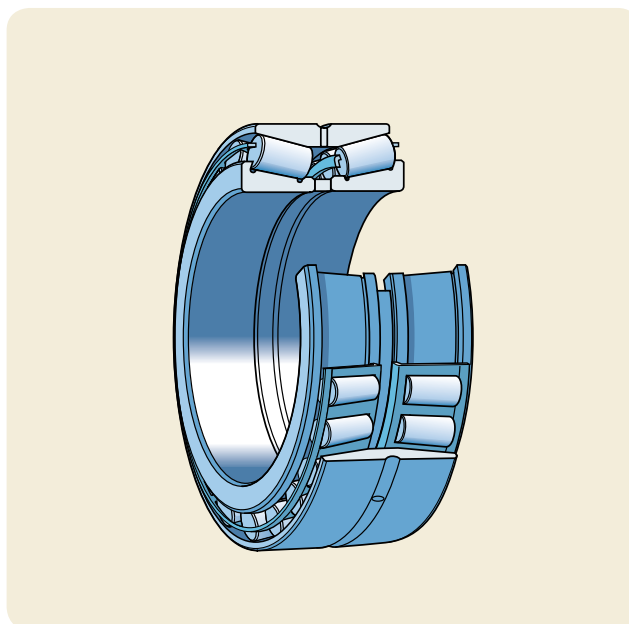
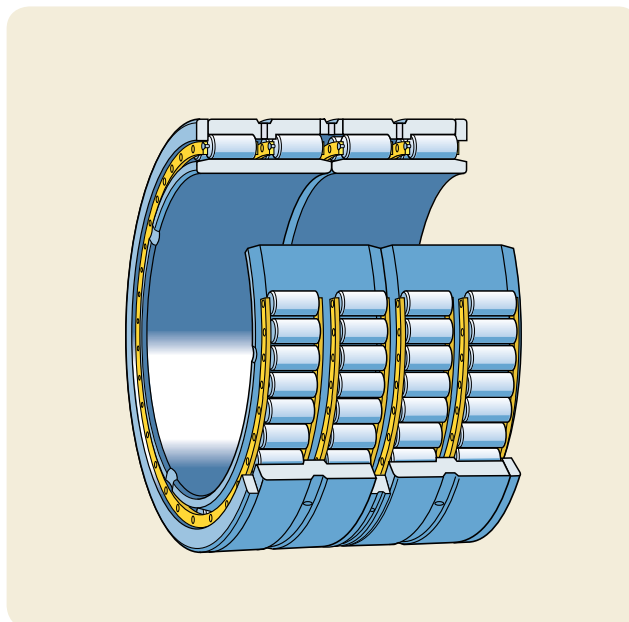
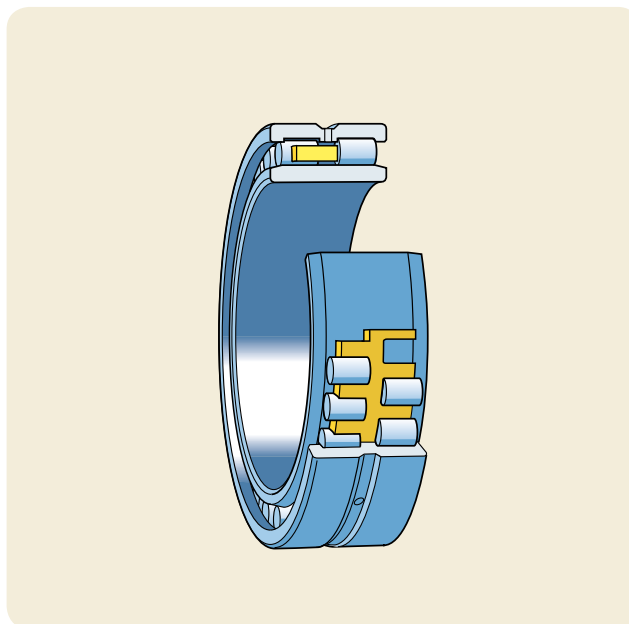

Other SKF products

Four-row taper roller bearings

Four-row taper roller bearings are used for rolling mill bearing arrangements where rolling speeds are moderate. Because of their special attributes they are produced in several different designs and sizes.

The extensive SKF range of four-row taper roller bearings includes conventional designs with intermediate rings between the outer and/or inner rings, as well as new and modified designs. SKF four-row taper roller bearings are produced in

- the TQI configuration with two pairs of roller sets arranged back-to-back
- the TQO configuration with two pairs of roller sets arranged face-to-face.

Available with either a cylindrical or tapered bore, many sizes are also available with seals on one or both sides of the bearing.

Taper roller thrust bearings

Taper roller thrust bearings enable axially compact bearing arrangements that can accommodate very heavy axial loads. These stiff bearing arrangements are insensitive to shock loads.

SKF produces taper roller thrust bearings as

- caged or full complement single direction bearings, e.g. for kingpin bearing arrangements in commercial vehicles
- double direction bearings for rolling mill applications
- screw-down bearings for the screw spindles in rolling mill applications.

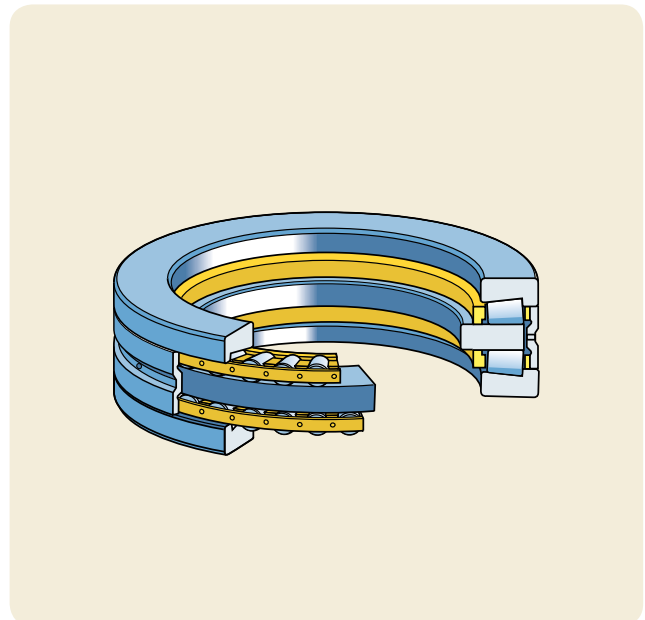
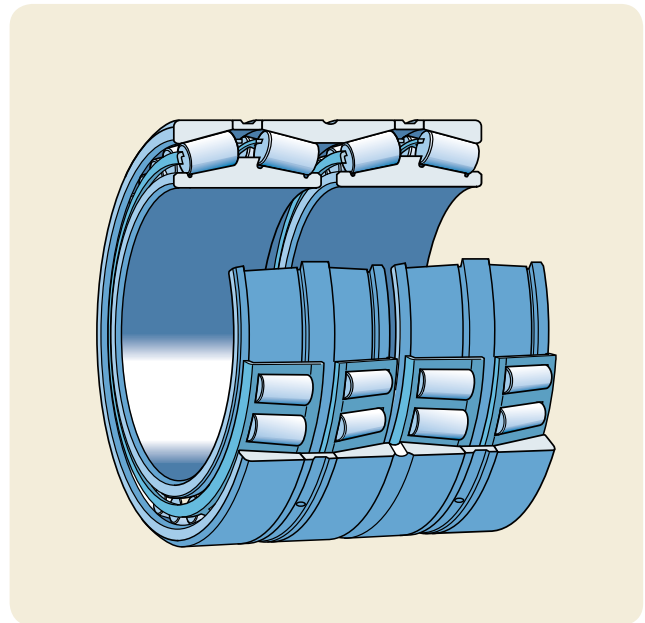

Additional information can be found in the “SKF Interactive Engineering Catalogue”.

Split cylindrical roller bearings

Split cylindrical roller bearings are used primarily for bearing arrangements, that are difficult to access or for crank shafts and other applications where the maintenance or replacement of non-split bearings would require considerable time and effort and would cause long, expensive or even unacceptable machine downtime.

SKF produces single row and double row split cylindrical roller bearings to order. The designs of the bearings are tailored to the application.

Additional information can be found in the “SKF Interactive Engineering Catalogue”.

Split spherical roller bearings

Split spherical roller bearings are used primarily for bearing positions that are difficult to access such as crank shafts, or long shafts where several support positions are required. They are also used in applications where non-split bearings would require considerable time and effort for replacement causing unacceptably long machine downtime.

SKF split spherical roller bearings are produced to order in several designs. The designs are tailored to the particular application and, for cost reasons, they are generally based on available bearings of standard design.

Additional information can be found in the “SKF Interactive Engineering Catalogue”.

Split CARB® toroidal roller bearings

Split CARB bearings are available as completely split units, which are sealed and water-cooled for bearing arrangements in continuous casters. They are a technically, well-proven solution for high quality requirements and maintenance-free operation.

Additional information can be found in the SKF brochure “Split bearing units for continuous casting plants”.

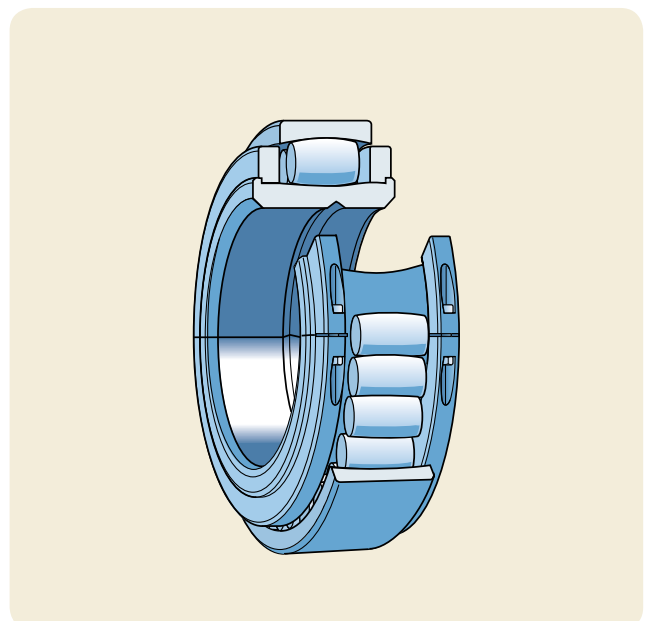
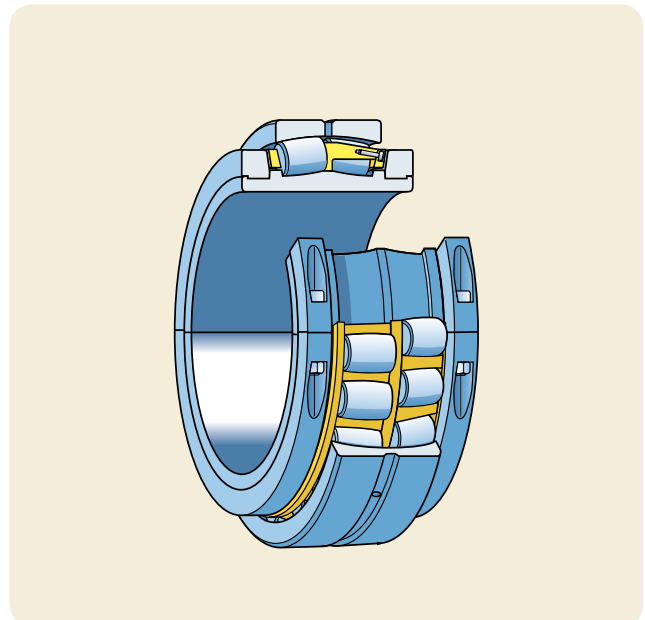
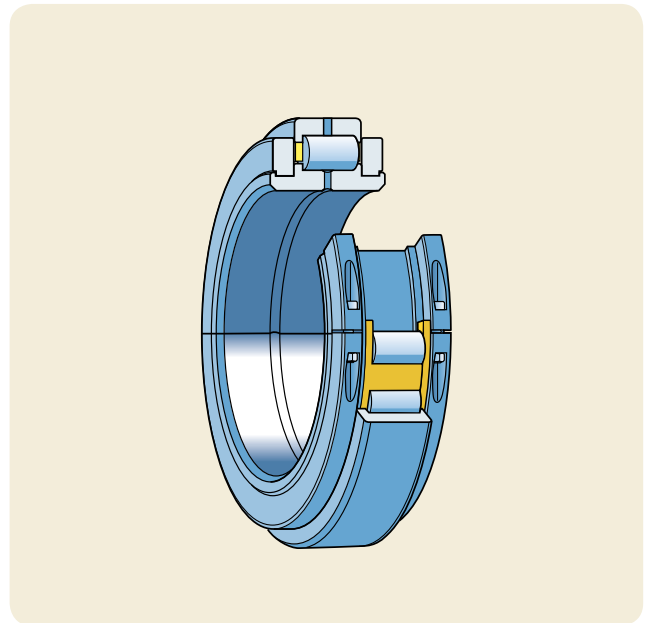

Other SKF products

Backing bearings for cluster mills

SKF backing bearings are generally based on double or multi-row cylindrical roller bearings. Single row needle roller bearing and double row taper roller bearing designs are also available. The logarithmic contact profile between the rollers and raceways of an SKF backing bearing for cluster mills provides excellent stress distribution under all load conditions, even when the bearing is misaligned under load. An optimized finish on all contact surfaces maximizes the effects of the lubricant.

For cluster mill bearings SKF also has bearing repair and rework facilities to return a used bearing to a “like-new” condition. If required, all the components of a backing bearing can be reworked.

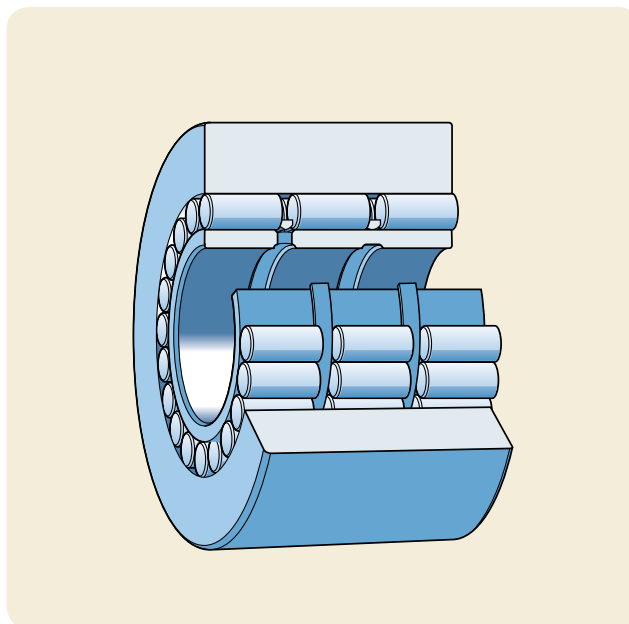

Indexing roller units for continuous furnaces of sintering plants

SKF indexing roller units were originally developed for use on the continuous furnaces of sintering and pelletising plants. These ready-to-mount units are also suitable for applications where there are very heavy loads and the direction of rotation is frequently reversed, or where rotational speeds are low.

Additional information can be found in the “SKF Interactive Engineering Catalogue”.

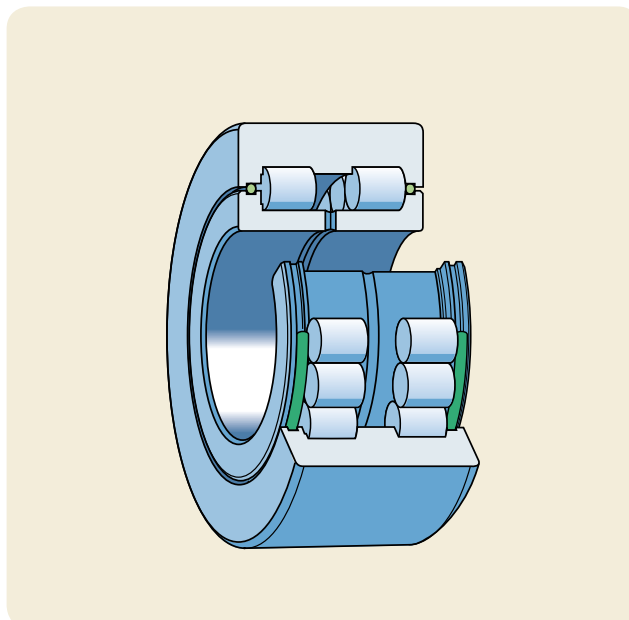

Crossed taper roller bearings

Crossed taper roller bearings are particularly compact double direction taper roller thrust bearings and are mainly used in tables of machining centres, milling and drilling machines as well as radar antennae and welding robots.

SKF crossed taper roller bearings consist of an outer ring and a two-piece inner ring. Tapered rollers are arranged between the rings, with every second roller placed at approximately right angles to the adjacent roller. Plastic discs separate the rollers. Because of their special internal geometry the power loss at the roller end contacts is minimal and heat generation is low.

Further information will be supplied on request.



Slewing bearings

Slewing bearings are ball or cylindrical roller bearings that can accommodate axial, radial and moment loads acting either singly or in combination and in any direction. They are not mounted on a shaft or in a housing; the rings, which are simply bolted on the seating surface are available in one of three executions

- without gears
- with an internal gear
- with an external gear.

Slewing bearings can perform both oscillating (slewing) movements as well as rotating movements.

The outside diameter range of SKF slewing bearings with a one-piece ring is from 400 to 7 200 mm. Even larger bearings are produced with outside diameters up to 14 000 mm, but these have segmented rings. Some of the smaller sizes, up to approximately 2 000 mm outside diameter are standard production.

Further information will be supplied on request.

Single row slewing ball bearings

SKF single row slewing ball bearings are four-point contact ball bearings. The balls are inserted through a filling slot which is plugged afterwards. The bearings are sealed, have no preload and are intended for applications where demands regarding accuracy are moderate.

Single row slewing roller bearings

SKF single row slewing roller bearings are crossed cylindrical roller bearings. Every second roller is at right angles to its neighbouring roller. The rollers are inserted through a filling slot which is plugged afterwards. The bearings are under preload and have integral lip seals.

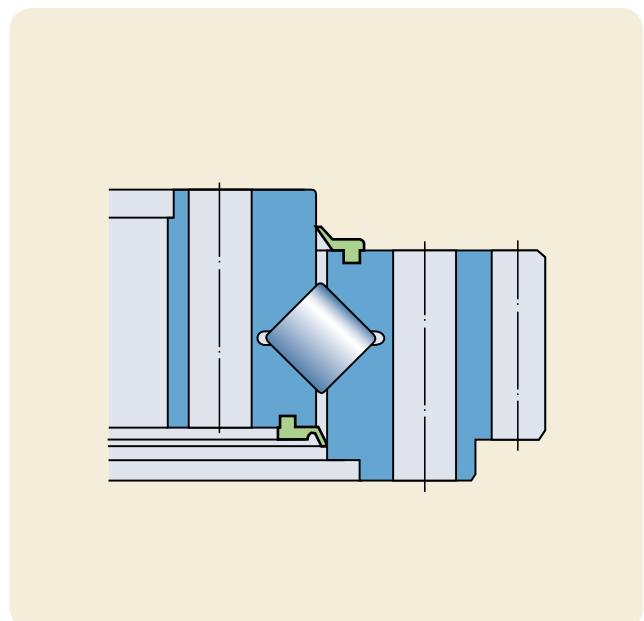
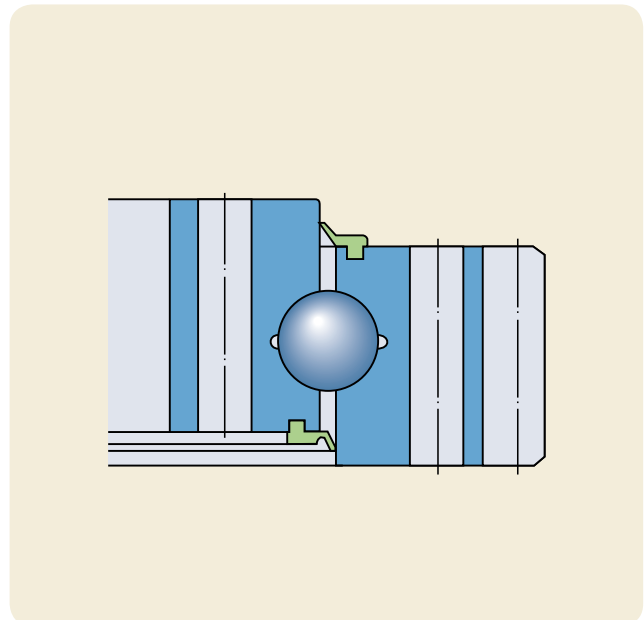
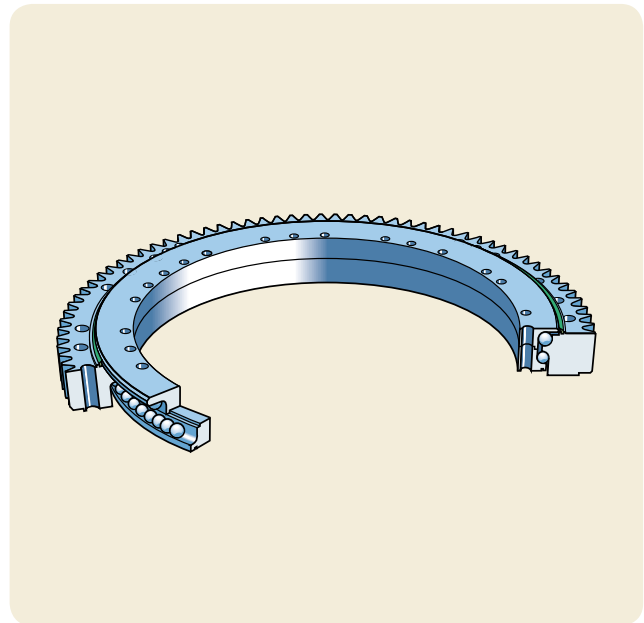

Other SKF products

Double row slewing bearings

These slewing rings are angular contact cylindrical roller bearings. The rollers are inserted through filling slots in one of the rings; the slots are plugged afterwards. Plastic separators provide optimum roller guidance. The bearings are normally preloaded and are fitted with integral lip seals.

Triple row slewing bearings

Triple row slewing bearings are combined radial and thrust cylindrical roller bearings for very heavy loads with one one-piece and one two-piece ring. The bearings are not under preload and have integral lip seals. These bearings place high demands on the seating surfaces.

Other slewing bearings

In addition to the standard designs outlined above, SKF also produces several other designs, for a multitude of applications, to order. These include

- slewing bearings as combined cylindrical roller/ball bearings
- slewing bearings as double row angular contact ball bearings
- dry sliding slewing bearings
- slewing bearings with integral drive.

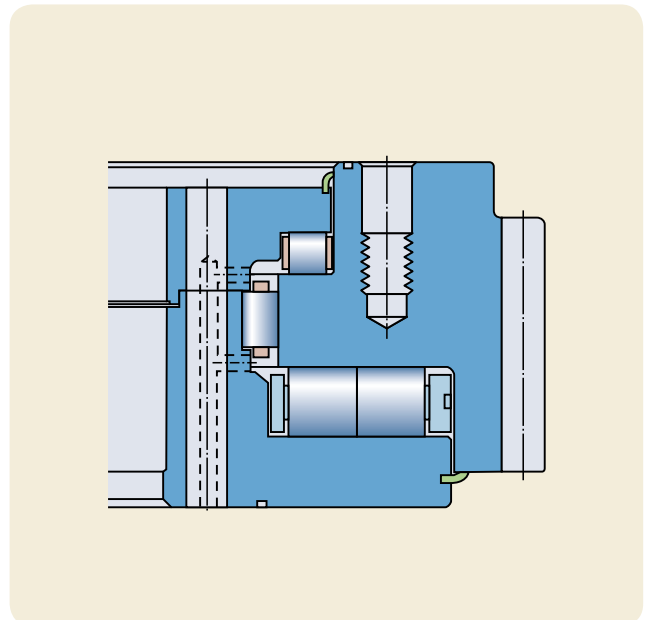
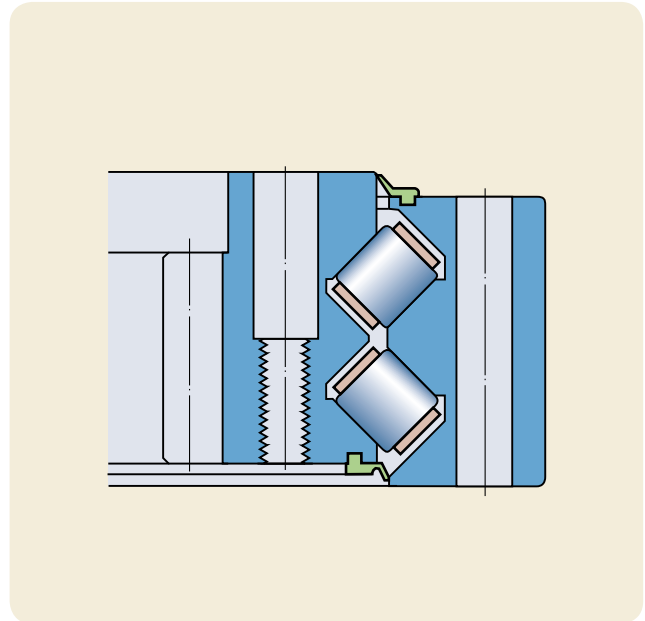

Specials for special applications

Products for railway vehicles

Bearings are used for a wide variety of purposes in all kinds of railway vehicles. They are key components in axleboxes and drive systems such as traction motors and suspension units. Other applications include gearboxes, shock absorbers, tilting mechanisms, doors etc. The latest development involves sensors to detect speed, direction of rotation, bearing condition and bogie stability. These are now becoming standard equipment for several modern train designs. Some product examples are

- compact tapered roller bearing units with metric or inch dimensions
- axleboxes designed for overall economy, reliability and comfort
- axlebridges for low floor tramcars supporting the two independent wheels fitted with tapered bearing units.

For more information, please visit www.railways.skf.com.



Other SKF products

Products for automotive applications

SKF supplies a wide variety of standard and special bearings, including sensorized bearings as well as ready-to-mount bearing units, to the automotive industry for different car and truck applications. The range includes

- car hub units
- truck hub units
- belt tensioner units
- water pump spindles
- clutch release bearings
- drive shaft (propeller) and intermediate shaft support bearings
- drive shaft (propeller shaft) centring bearings
- suspension bearings
- free wheels (sprag clutches).



Vehicle replacement parts

A comprehensive range of vehicle kits is also available for replacement purposes for a wide selection of cars and trucks. These kits contain everything the mechanic needs to do the complete job which includes not only the requisite bearings, but the appropriate accessories such as seals, nuts, retaining rings etc. The range of kits includes

- hub bearing kits for cars
- hub bearing kits for trucks
- synchronous drive and belt tensioner kits
- clutch release bearings kits for cars
- clutch release bearing kits for trucks
- water pump kits
- suspension bearing kits.

For more information about automotive aftermarket products, please visit www.vsm.skf.com.



Other SKF products

High-precision bearings for machine tools

SKF manufactures a wide range of high-precision bearings, that are intended for use in machine tool applications and other applications where accuracy and high speed capabilities are important. SKF precision bearings are available in several ISO Dimension Series and in a wide range of sizes. The product range includes traditional all-steel bearings as well as hybrid bearings. For more information, please refer to the SKF catalogue "High-precision bearings".

Single row angular contact ball bearings

SKF high-precision all-steel and hybrid angular contact ball bearings are available as normal as well as high-speed bearings in three ISO Dimension Series with two different contact angles each.

Cylindrical roller bearings

SKF offers both single row and double row cylindrical roller bearings as all-steel or hybrid bearings. They feature low cross-sectional height, high load carrying capacity and high speed capability.

Double direction angular contact thrust ball bearings

SKF offers three series of high-precision angular contact thrust ball bearings with different contact angles as all-steel or hybrid bearings. They are specially suited to applications demanding accuracy and rigidity of machine tool work spindles.



Single direction angular contact thrust ball bearings

SKF single direction angular contact thrust ball bearings are designed for use in precision ball screws. They provide high load ratings and speed capability, superior axial rigidity and extreme running accuracy. They can be ordered as single bearings, universally matchable bearings and as matched sets. They are also available as ready-to-mount cartridge units.

Magnetic bearings

Magnetic bearings are used in a variety of applications e.g. turbomolecular pumps, compressors, turbo generators, semiconductor equipment and high speed machine tools. They levitate the shaft by inducing a controlled magnetic field. This means that the shaft is rotating without contact. The system senses the shaft position and adjusts the force in real time keeping the shaft at the required position.

Some of the benefits of magnetic bearings are

- no contamination from wear
- lubrication-free
- operate in severe environments e.g. extreme high and low temperatures, ultra-high vacuum or submerged applications
- minimal vibration transferred to housing
- precision control and elimination of shaft runout caused by unbalance
- built-in condition monitoring of rotor dynamics of vibration and forces.

SKF offers a full range of magnetic bearing products like

- magnetic bearings
- digital controllers
- DC brushless motors
- hyperspin spindles
- engineered shaft solutions.

For more information, please visit www.revolve.com.



Other SKF products

Products for the pulp and paper industry

SKF meets the demands of the pulp and paper industry by offering customized solutions, both in the area of products and services, for example

- self-aligning bearing systems using a spherical roller bearing as the locating bearing and a CARB toroidal roller bearing at the non-locating position, which accommodate axial expansion and deflections, decrease vibrations and increase service life
- a standard range of housings, designed for high flow circulating oil lubrication, with maintenance-free sealing arrangements
- condition monitoring equipment to virtually eliminate unplanned downtime.

The SKF handbook “Rolling bearings in paper machines” provides information on bearing selection and how to maximize bearing service life. The handbook is available on request.

Triple ring roller bearings

Triple ring roller bearings are used almost exclusively in paper machines for the support of variable crowned press rolls at the drive side. SKF produces three different inner/outer bearing combinations

- cylindrical/spherical roller bearing
- spherical/cylindrical roller bearing
- spherical/spherical roller bearing.

Additional information can be found in the SKF catalogue “Large bearings”.

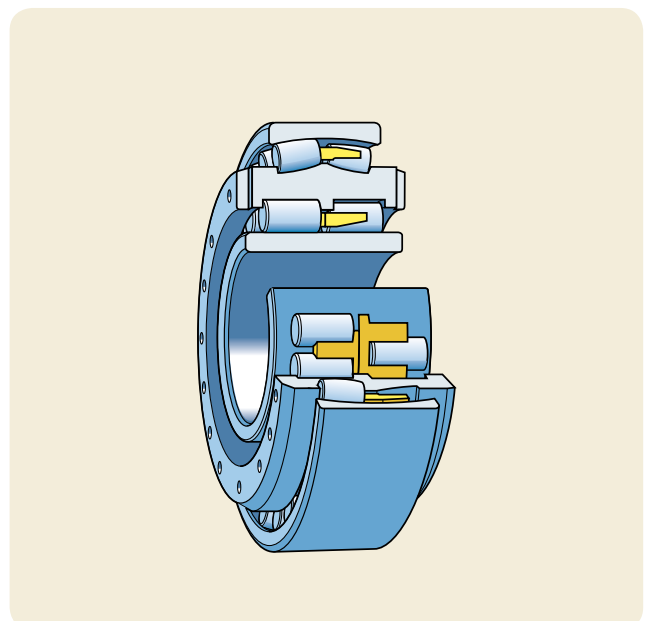

Bearings for the printing industry

For many years SKF has been the partner to the printing industry through continuous innovation and development of customized products and solutions to increase productivity, improve printing quality and to support the need for maximum machine reliability. Examples of SKF specials for printing machines include

- the PCU – a Printing Cylinder Unit, that facilitates print on/off in printing presses required during printing operation
- the SKF PANLOC – a bearing unit, that permits the axial displacement of the shaft in both directions without generating internal axial forces and enables clearance or preload to be adjusted
- the Recommended Product Range – an application-oriented bearing selection from the comprehensive SKF range. To choose a bearing from this recommended product range means short delivery times, worldwide availability and no minimum order quantities.

In addition SKF offers a complete assortment of linear motion products, complete service solutions as well as maintenance-free concepts, mechatronics and measuring instruments for printing machine manufacturers and operators.

For more information, please visit www.printing.skf.com.



Other SKF products

Products for aerospace applications

Aeroengine products

The aeroengine product range includes main shaft and gearbox bearings for helicopters and jet engines. Bearing types include ball bearings and spherical, cylindrical and taper roller bearings. The SKF aerospace specialists MRC Bearings, SKF Avio and SKF Aeroengine UK also offer bearing refurbishment services to airlines and aircraft engine overhaul facilities, which restore used aeroengine bearings to like-new condition. In addition to aeroengine products and services, MRC also manufactures specialty aerospace quality steel and ceramic rolling elements that are used in highly engineered industrial and aerospace applications. The MRC Specialty Bearings business unit manufactures high performance custom designed bearings for technically and environmentally demanding applications.

For more information, please visit www.mrcbearings.com.

Flight control components and assemblies

SKF Airframe, comprising SKF Aerospace France and SKF (U.K.) Ltd, Aerospace Division, is the European leader in design and manufacture of flight control components and assemblies. SKF Airframe's state-of-the-art facilities are equipped with the latest technology for R&D, testing, production, quality and information technology. Three product ranges are offered

- metallic and composite rods and struts for structural and flight control applications
- ball, roller and spherical plain bearings for landing gear, flight controls, wings and engine links
- a wide range of mechatronic products including position and force transducer units, linear and rotary actuators, for cockpit, flight control and utilities actuation.

For more information, please visit www.skf-aerospace.fr.

Aero sealing products

SKF Aerospace, Sealing Solutions (located in the USA) offers enhanced high-performance shaft seals and wear sleeves of various designs and materials used in aerospace applications worldwide.



Seals

Seals represent an important part of the SKF business. The SKF range consists of seals in contact with stationary or sliding surfaces and covers virtually all application requirements. Not just simple sealing arrangements, but a wide range of seals for demanding industrial applications. From design concepts to high volume production, from original equipment to aftermarket, SKF can provide sealing solutions to its customers.

Detailed information can be found in the catalogues "Industrial seals" and "Hydraulic seals". The standard range of dynamic SKF seals for rotating machine components is also listed in the "SKF Interactive Engineering Catalogue".

For additional information, please visit www.sealpool.com and www.chicago-rawhide.com.

Seals for rotating machine components

- Radial shaft seals
- Mechanical seals
- V-ring seals
- Axial clamp seals
- Wear sleeves for shaft repairs

Seals for reciprocating components

- Hydraulic piston seals
- Hydraulic rod seals
- Wiper seals
- Guide rings and guide strips

Seals for stationary surfaces

- O-rings
- Back-up rings

PTFE seals for different purposes

- Piston and rod seals
- Wiper seals
- Guide strips
- Radial shaft seals
- PTFE encapsulated O-rings



Centralized lubrication systems

Components, assemblies and complete systems for the lubrication technology are also part of the SKF business. The competent SKF company for these products is the Willy Vogel AG, the world leader in the field of centralized lubrication systems for machines and industrial, commercial or rail bound vehicles. The product range of lubrication and circulating oil systems essentially includes the following products briefly described.

Detailed information can be found in the Vogel brochure "Overview of Products for Industry: Centralized lubrication and minimal quantity lubrication for machinery and systems". For additional information please visit the website www.vogelag.com.

Generally there are two types of centralized lubrication systems: total-loss lubrication systems and circulating lubrication systems.

Total-loss centralized lubrication systems

Centralized lubrication systems feed a small and always fresh amount of lubricant to each lubrication point at requisite intervals, in line with a predetermined need. The residual lubricant that escapes from the lubrication point at some time is disposed of (in case of industrial applications) or is lost (in case of commercial or rail bound vehicles).

Depending on the operating conditions total-loss centralized lubrication systems can be designed as

- single-line systems
- dual-line systems
- multi-line systems

equipped with components individually needed. The applicable lubricants range from oils with a viscosity of 2 to 16 000 mm²/s and fluid greases with an NLGI consistency class of 0, 00 and 000 to consistent greases with an NLGI consistency class of 1, 2 and 3.



Circulating oil lubrication systems

In circulating oil lubrication systems the oil is supplied to the lubrication points with the aid of pumps. After passing the lubrication point the lubricant returns to a tank or sump where it is filtered before being returned to the lubrication points. Generally a larger quantity of oil is supplied to the lubrication points than actually needed.

For circulating oil lubrication systems a variety of components are available enabling tailor made solutions for all types of industrial applications. A continuous flow of oil produced by a pump and then divided up is required for machines or installations that use large amounts of oil for lubricating and cooling purposes.

The lubricant for the lubrication points is apportioned by progressive feeders, flow limiters, flow controllers and/or flow meters.

Multi-circuit circulating oil systems

Vogel multi-circuit circulating oil supply systems are custom-designed and suitable for all types of hydrostatic shoe bearing arrangements that carry large rotating drums. They are modern systems, use state-of-the-art components and enable stable pressure at each individual bearing point.

Chain lubrication systems

Vogel chain lubrication systems are customized, fully automatic systems for lubrication of drive or conveyor chains in all types of industrial applications. They enable environmental friendly systems that deliver precisely metered quantities of lubricant while the machine is in operation.



Other SKF products

Oil+air lubrication systems

Modern oil+air lubrication systems are mainly used to supply extremely small amounts of oil to bearing arrangements, e.g. in spindles of machine tools or in linear guidance systems. They deliver a precise metered quantity of lubricant to each bearing to improve the operating reliability and reduce the consumption.

Splash and spray systems

These systems are manufactured on demand and custom-made to fulfil the needs of a specific application. They are typically used in customized handling equipment, for example, to spray lubricants onto conveyor belts or to spray billets and stampings with oil.

Minimal quantity lubrication systems

Minimal quantity lubrication is the clean alternative to wet machining and an optimal way to supplement dry machining. It can be used to optimize machining processes like milling, rolling, high speed cutting, drilling, boring or tapping, for example. The oil or emulsion supplied to the working surface gets lost and no residue is left. These minimal quantity lubrication systems, which carry the trademark LubriLean[®], provide considerable technology advantages. In addition, these systems can be used to reduce costs and increase productivity.



SKF system solutions

SKF Copperhead

SKF Copperhead is a system solution for vibrating screens, crushers, mills, conveyors and other mineral processing equipment. It enables fault detection monitoring of the equipment, including the bearing arrangements using vibration and temperature sensors. The SKF Copperhead system comprises the appropriate spherical roller bearings and CARB toroidal roller bearings (both of the SKF Explorer performance class), sensors and monitoring units. The system extends equipment service life and reduces costly unplanned downtime. Either manual, periodic or continuous monitoring is available.



BoMo bogie monitoring system

The bogie monitoring system for railways (BoMo) enables continuous condition monitoring for bogies of railway vehicles as well as data collection of essential operating parameters such as speed, direction of rotation, temperature and vibration. This system solution, developed by SKF and Sécheron, improves safety and reduces life cycle costs.



SKF WindCon solution for wind turbines

SKF WindCon is a tailored monitoring system for wind turbines, especially for offshore wind parks. The system enables continuous data collection of all operational parameters including tower and blade vibration.

The system consists of a monitoring unit in the nacelle and the SKF knowledge based Pro-Con software program that collects and analyses data to detect changes in the wind turbine's key performance parameters.



Other SKF products

SKF Smart Chock Unit

The SKF system solution “Smart Chock Unit” provides reliable online monitoring of rolling mill bearing arrangements. In addition to the intelligent software, the system includes appropriate sensors and wires. The SKF Smart Chock Unit enables rolling mill operators to

- continuously monitor the condition of roll neck bearings
- change from preventive to predictive maintenance
- reduce downtime
- improve quality of rolled material.



SKF ConRo system for continuous casters

Typical operating conditions in continuous casters include heavy loads, very low speeds, elevated temperatures and huge amounts of cooling water. The SKF ConRo system is a maintenance-free roll unit designed for just these types of severe operating conditions. ConRo enables the operators of continuous casters to reduce the total costs and improve productivity.



SKF bearing carrier

This SKF solution was designed for weight sensitive applications such as automotive gearboxes, where it is difficult to accommodate the occurring loads in light-alloy housings. The SKF bearing carrier unit consists of a rigid sheet steel carrier and the appropriate integrated rolling bearings. The tailored bearing unit safely accommodates the occurring loads and distributes them to a large housing surface. Another advantage is quick and low-cost assembly.



Spindle units

With design and production facilities in Germany, Italy, Japan and North America, SKF is a worldwide supplier of a complete range of spindles – from externally driven and motor integrated spindles with rolling bearings to high performance gas and magnetic bearing spindles. SKF knowledge in bearing technology, sensors and electronics is the base to satisfy specific requirements for precision machining and processing. And it enables SKF to develop tailor-made spindle units together with the customer.

SKF machining centre spindles

Machining centre spindles are designed for milling, tapping and drilling operations. High stiffness, accuracy and low operating temperature are important operational requirements for these applications. SKF offers motor integrated spindles for speeds up to 30 000 r/min as well as belt driven spindles for machining centre applications.

SKF high-speed milling spindles

SKF high-speed milling spindles are used in applications, where high cutting rates are the norm or where fine surface finishing is required. They are also widely used when cutting advanced geometries which requires a well balanced spindle with good thermal stability. SKF offers state-of-the-art technology with a system of sensors, automatic clamping and cooling through the shaft for speeds up to 60 000 r/min.

SKF turning spindles

The SKF turning spindles are designed to withstand high cutting forces and to provide high productivity while running accuracy enables good surface quality. The thermally stable spindles are robust and provide a space saving design. SKF offers motor integrated spindles for speeds up to 10 000 r/min and belt driven ones up to 16 000 r/min.



Other SKF products

SKF grinding spindles

Like the spindles in SKF bearing manufacturing plants, high frequency grinding spindles are designed for high operating speeds and high precision. The standard range has a simple and robust design. Speeds range from 10 000 to 180 000 r/min. In addition to the catalogue product range, SKF produces a wide range of spindle solutions, such as coolant-through or to accommodate automatic tool change.

SKF magnetic bearing spindles

SKF is currently working on magnetic bearing spindle technology. The features of magnetic bearing spindles are the advanced digital control and real time information diagnostics, which offer improved cutting finish and process optimization.

Hyperspin, a magnetically levitated spindle, provides a total shaft solution complete with a digital control system, integral motor and motor drive.

SKF Spindle Service

The SKF Spindle Service supports customers worldwide with spindle repair centres in Europe, North America and Japan. The services offered include spindle reconditioning, from bearing replacement to shaft and nose restorations, performance upgrades and analysis. SKF can also provide complete monitoring services as well as preventative maintenance services for machine tool spindles.



Linear motion products

Linear guidance systems

- Linear ball bearings with recirculating range ball tracks which provide low friction movement and the possibility of unlimited stroke.
- Speedi-Roll, the cam roller type rail guide system suitable for applications with long strokes and/or high speeds.
- Profile rail guides with high load carrying capacity, high stiffness and unlimited stroke.
- Precision rail guides with limited strokes for high stiffness and position accuracy.



High efficiency ball screws

In all types of ball screws, the load is transmitted from the screw shaft to the nut through the recirculating balls; several recirculating systems are available. To improve positioning accuracy, backlash can be reduced or eliminated.

High efficiency roller screws

Two non-competing designs cover requirements beyond ball screw limitations. Load transferred from the nut to the screw shaft through a number of threaded grooved rollers; the resulting large number of contact points provide a much higher load carrying capacity and a much longer life than ball screws of similar size.



Other SKF products

Linear actuators

Linear actuators are designed for a variety of applications. Each actuator is maintenance-free and is equipped with either a sliding screw or a ball screw. Limit switches, encoders or potentiometers are also available.

Positioning systems

Positioning systems provide compact and economical solutions for guided and driven applications. They may be designed to meet special requirements.

For more information, please visit www.linearmotion.skf.com.

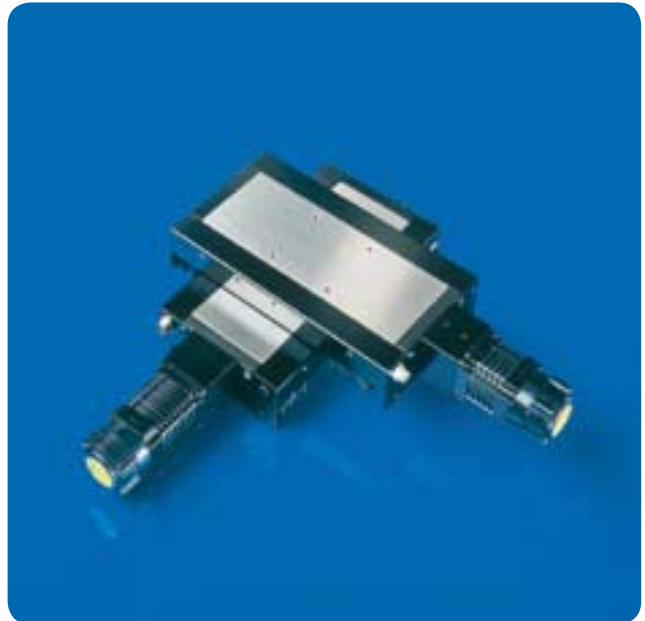

Plain bearings

Spherical plain bearings and rod ends

Spherical plain bearings, which are designed for slow movement applications, can accommodate misalignment and oscillating movements. They have a very high load carrying capacity and are ready to mount. Spherical plain bearings are available with various sliding combinations: steel on steel, which requires lubrication, or the maintenance-free combinations steel on sinter bronze composite, PTFE fabric or PTFE composite. SKF offers a very comprehensive range:

- Radial spherical plain bearings in metric or inch dimensions, with seals and/or an extended inner ring.
- Angular contact spherical plain bearings for combined radial and axial loads.
- Spherical plain thrust bearings for thrust loads and in combination with a radial spherical plain bearing for heavy duty arrangements.
- Rod ends with integral spherical plain bearings with male or female threads or with cylindrical or rectangular section welding shank.

For detailed information, please refer to the catalogue “SKF spherical plain bearings and rod ends” or the “SKF Interactive Engineering Catalogue”. The SKF Interactive Engineering Catalogue supports the selection of products through calculation facilities.



Other SKF products

Bushings

SKF offers the world's widest assortment of stock bushings. The range is suitable for rotating, oscillating and linear movements. Cylindrical and flanged bushings, thrust washers and strips are available. Different materials serve different requirements.

- Solid bronze, the traditional robust material.
- Sintered bronze with oil impregnation for high sliding velocities.
- Wrapped bronze with lubrication pocket for contaminated environments.
- PTFE composite for long service life due to low friction.
- POM composite for low maintenance under tough conditions.
- Stainless backed composite, maintenance-free in corrosive environments.
- PTFE polyamide, cost effective and maintenance-free.
- Filament Wound for extreme conditions.

For detailed information, please refer to the brochure "SKF bushings", containing comprehensive selection guidance or the "SKF Interactive Engineering Catalogue".

Special solutions

Together with customers, SKF develops special solutions incorporating plain bearings especially for road and rail vehicles and the aircraft industry. For more information, please visit www.skf-aerospace.fr or www.ampep.co.uk.



Bearing units

Y-bearing units

Standard SKF ball bearing units are referred to as Y-bearing units. Y-bearing units are ready-to-mount units which can accommodate initial misalignment. The unit consists of a single row deep groove ball bearing with convex sphered outside diameter (Y-bearing) and a Y-bearing housing, which has a correspondingly sphered but concave bore. Bearings and housings can be ordered separately. SKF Y-bearing units are available as

- Y-bearing plummer (pillow) block units
- Y-bearing flanged units
- Y-bearing take-up units.

A variety of designs is available with different housing materials like

- composite material
- grey cast iron
- sheet steel

and there is a choice of locking method on the shaft like

- grub screw locking
- eccentric collar locking
- adapter sleeve locking.

For detailed information about SKF Y-bearing units, please refer to the SKF catalogue “Y-bearings and Y-bearing units” or the “SKF Interactive Engineering Catalogue”.



Other SKF products

SKF ConCentra ball and roller bearing units

SKF ConCentra bearing units use the SKF concentric locking technique. With a patented multi-tapered sleeve a concentric interference fit with the shaft is achieved. The units are easy to mount and dismount with a hexagonal key. The true concentric mounting enables bearing arrangements to operate at higher speeds with less vibration resulting in quieter running and longer service life.

SKF ConCentra ball bearing units

SKF ConCentra ball bearing units use Y-bearing housings together with a deep groove ball bearing based on SKF bearings in the 62 series. They can be supplied for metric or inch shafts from 25 to 60 mm or 1 to 2 1/16 inch respectively. The units use a low friction contact seal protected by an additional flinger.

For detailed information about SKF ConCentra ball bearing units, please refer to the product brochure “SKF ConCentra ball bearing units – true concentric locking, for fast and reliable mounting”.

SKF ConCentra roller bearing units

SKF ConCentra roller bearing units are based on SKF Explorer spherical roller bearings in the 222 series. The units are available for metric or inch shafts from 35 to 75 mm or 1 7/16 to 4 inch respectively. The units are available with either contact or labyrinth seals. As standard, all plummer block units are available in a locating and a non-locating version.

For detailed information about SKF ConCentra roller bearing units, please refer to the product brochure “SKF ConCentra roller bearing units – true concentric locking, for fast and reliable mounting”.

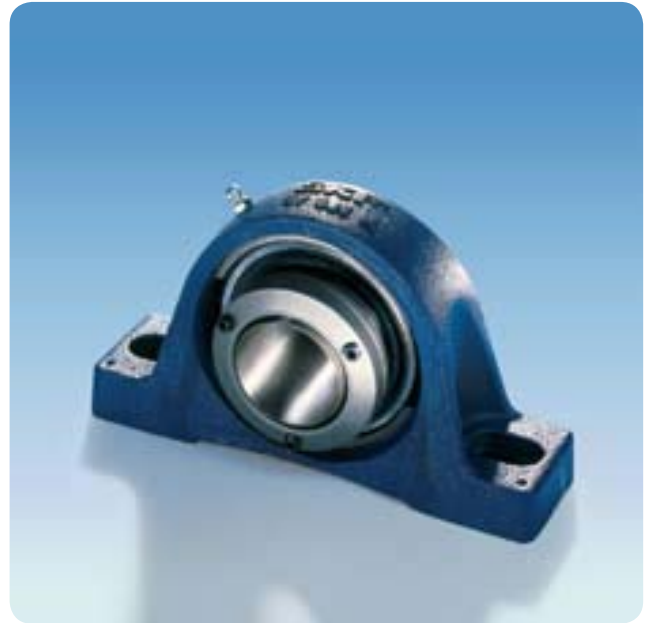

Collar mounted roller bearing units

SKF collar mounted roller bearing units are ready-to-mount bearing units, which are greased and sealed, and are able to compensate for misalignment of the shaft with respect to the housing. They consist of a bearing housing and an SKF Explorer spherical roller bearing based on the 222 series. The bearing can be secured to the shaft with a locking collar with grub (set) screws.

SKF collar mounted roller bearing units are available as

- plummer (pillow) block bearing units
- flanged bearing units
- take-up bearing units.

More information can be found in the “SKF Interactive Engineering Catalogue”.

Two-bearing units

SKF two-bearing units were originally designed for use on fan shafts with an overhung impeller. However, they are being used in other applications, e.g. centrifugal pumps, circular saws and grinding spindles. Two-bearing units offer a more compact design, improved running accuracy, quiet operation, and easy installation.

Several series with different bearing arrangements are available to meet different application requirements.

More information can be found in the “SKF Interactive Engineering Catalogue”.

Support and thrust roller assemblies

Many rotary drums or tubes have girth rings. The radial guidance is provided by support rollers and the axial guidance by thrust rollers. SKF supplies complete ready-to-mount support and thrust roller assemblies. They are well-proven units and the incorporated roller bearings offer high operational reliability coupled with minimum maintenance requirements. The assemblies can be selected from two standard ranges, one for support rollers and one for thrust rollers.



Other SKF products

Hydrostatic shoe bearings

Developments in various industrial sectors have led to the use of increasingly large bearings to carry increasingly heavy loads. Examples of these applications include the drums used to grind ore and cement and the debarking drums used in pulp production. The drums have in some cases reached a size where conventional rolling bearings or bearing units cannot be used. SKF developed the hydrostatic shoe bearing for just this type of application. It is a plain bearing, complete with auxiliary hydraulic equipment that supports the drum via girth rings around its circumference. In addition to having very high load carrying capacity these bearings have the following advantages

- no limit to bearing size
- friction is negligible
- virtually no wear
- bearing life is almost unlimited
- the sliding surfaces are self-aligning
- demands on accuracy of form of the trunnion or runner to be supported are moderate.

The SKF range comprises hydrostatic shoe bearings for horizontal as well as vertical bearing arrangements and also includes combined hydrostatic bearings with integral axial guidance.

For more information please contact the SKF application engineering service.

Auto-balancing

Imbalance is the standard cause of vibration in rotating equipment. It often varies with time and is difficult to correct. The DynaSpin™ auto-balancer is a unique solution that continually counteracts imbalance in rotating machinery. The freely moving balls, with the dynamic power of natural forces, automatically shift their position creating a balance that remains constant, regardless of the unbalance variations. The action dampens the vibration of the machine significantly.

For more information about the DynaSpin auto-balancer, please visit www.dynaspin.skf.com.



Fastening systems, rolling elements

Shaft couplings

SKF oil injection shaft couplings of type OKC and OKF join two shaft ends rigidly to each other. They are widely used in heavy torque applications where power has to be reliably transmitted. Applications range from joining the propeller shafts on a ship to connecting shafts in rolling mill drives.

SKF oil injection couplings are available as cylindrical or flanged couplings for diameters ranging from 100 to 1 000 mm. For more information, please ask for the publication “OK oil injection couplings from SKF” or visit www.couplings.skf.com.

Supergrip bolts

SKF Supergrip bolts, based on the SKF oil injection principle, are compared with traditional bolt systems easier to install and remove and therefore offer important technical as well as economic benefits. They are typically used in applications where rotating flanged joints are subjected to heavy torque loads and downtime is particularly expensive, e.g. a ship’s propeller shafts, steering equipment, steam turbines or rolling mills.

SKF Supergrip bolts are available for hole diameters starting from 40 mm.

For more information, please ask for publication “The SKF Supergrip Bolt for Rotating Flanges” or visit www.couplings.skf.com.



Other SKF products

Bushings

Solid bushings for fully concentric locking of friction hub joints virtually eliminate the common problem with eccentricity in shaft joints. Robust mechanical locating devices for high torque transmission in slewing applications or belt and chain drives. The SHT design contains a slot for mounting in hubs. The SHR design is closed for welding.

For further information, please visit www.skftransmission.com.

SKF ConCentra bushings

Extremely low section height bushings for fully concentric locking of friction hub joints virtually eliminate the common problem with eccentricity in shaft joints. The SHL design is a light-weight locating device for moderate torque transmission e.g. in fans or slewing appliances.

Rolling elements

SKF also supplies loose rolling elements that include balls, as well as cylindrical and needle rollers. Using loose rolling elements it is possible to produce economic full complement bearing arrangements for very heavy loads and low speeds or oscillatory movement, provided the other associated components can take the form of raceways having the same hardness and quality as bearing rings.

The rolling elements are made of carbon chromium bearing steel or silicone nitride. Additional information will be supplied on request.

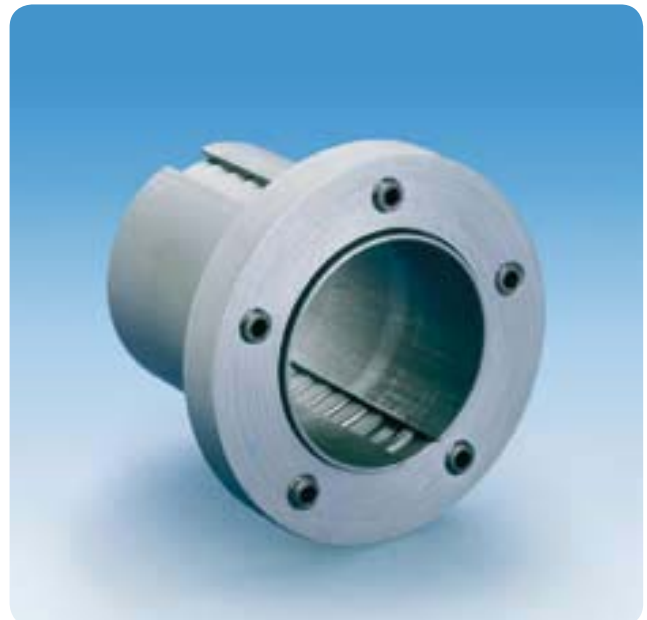

Product index

Series or type designation	Product	Page
02800	Single row inch taper roller bearing	642
03000	Single row inch taper roller bearing	640
07000	Single row inch taper roller bearing	642
09000	Single row inch taper roller bearing	640
10	Self-aligning ball bearing	484
11000	Single row inch taper roller bearing	648
112	Self-aligning ball bearing with extended inner ring	494
11500	Single row inch taper roller bearing	640
12	Self-aligning ball bearing	484
13	Self-aligning ball bearing	484
130	Self-aligning ball bearing	490
1300	Single row inch taper roller bearing	640
139	Self-aligning ball bearing	490
14000	Single row inch taper roller bearing	644
15000	Single row inch taper roller bearing	642
15500	Single row inch taper roller bearing	642
160	Single row deep groove ball bearing	304
160-Z	Single row deep groove ball bearing with one shield	330
160-2Z	Single row deep groove ball bearing with shields	330
16000	Single row inch taper roller bearing	646
161	Single row deep groove ball bearing	302
161-2RS1	Single row deep groove ball bearing with seals	328
161-2Z	Single row deep groove ball bearing with shields	328
18500	Single row inch taper roller bearing	648
18600	Single row inch taper roller bearing	652
18700	Single row inch taper roller bearing	652
1900	Single row inch taper roller bearing	642
2	Single row deep groove ball bearing with filling slots	366
2 NR	Single row deep groove ball bearing with filling slots	370
2-Z	Single row deep groove ball bearing with filling slots and one shield	366
2-2Z	Single row deep groove ball bearing with filling slots and shields	366
2-ZNR	Single row deep groove ball bearing with filling slots, snap ring and one shield	370
2-2ZNR	Single row deep groove ball bearing with filling slots, snap ring and shields	370
213	Spherical roller bearing	716
22	Self-aligning ball bearing	484
22-2RS1	Self-aligning ball bearing with seals	492
222	Spherical roller bearing	716
223	Spherical roller bearing	716
223/VA405	Spherical roller bearing for vibrating applications	744
223/VA406	Spherical roller bearing for vibrating applications	744
23	Self-aligning ball bearing	484
23-2RS1	Self-aligning ball bearing with seals	492
230	Spherical roller bearing	718
230-2CS	Spherical roller bearing with seals	742
230-2CS2	Spherical roller bearing with seals	742
231	Spherical roller bearing	718
231-2CS2	Spherical roller bearing with seals	740
232	Spherical roller bearing	718
232-2CS	Spherical roller bearing with seals	740
23600	Single row inch taper roller bearing	644
238	Spherical roller bearing	726
239	Spherical roller bearing	722
239-2CS	Spherical roller bearing with seals	742
240	Spherical roller bearing	718

Product index

Series or type designation	Product	Page
240-2CS2	Spherical roller bearing with seals	740
241	Spherical roller bearing	718
241-2CS	Spherical roller bearing with seals	742
241-2CS2	Spherical roller bearing with seals	742
243000	Single row inch taper roller bearing	666
24700	Single row inch taper roller bearing	648
248	Spherical roller bearing	730
249	Spherical roller bearing	734
25500	Single row inch taper roller bearing	648
25800	Single row inch taper roller bearing	644
2700	Single row inch taper roller bearing	646
28600	Single row inch taper roller bearing	652
292	Spherical roller thrust bearing	884
293	Spherical roller thrust bearing	884
294	Spherical roller thrust bearing	884
29600	Single row inch taper roller bearing	656
3	Single row deep groove ball bearing with filling slots	366
3 NR	Single row deep groove ball bearing with filling slots	370
3-Z	Single row deep groove ball bearing with filling slots and one shield	366
3-ZZ	Single row deep groove ball bearing with filling slots and shields	366
3-ZNR	Single row deep groove ball bearing with filling slots, snap ring and one shield	370
3-ZZNR	Single row deep groove ball bearing with filling slots, snap ring and shields	370
302	Single row taper roller bearing	618
302/DB	Single row taper roller bearing, paired back-to-back	688
302/DF	Single row taper roller bearing, paired face-to-face	680
302 R	Single row taper roller bearing with flanged outer ring	668
303	Single row taper roller bearing	618
303/DB	Single row taper roller bearing, paired back-to-back	688
303 R	Single row taper roller bearing with flanged outer ring	668
3057(00) C-2Z	Double row cam roller	466
3058(00) C-2Z	Double row cam roller	466
313	Single row taper roller bearing	618
313/DB	Single row taper roller bearing, paired back-to-back	688
313/DF	Single row taper roller bearing, paired face-to-face	680
313 X	Single row taper roller bearing	632
313 X/DB	Single row taper roller bearing, paired back-to-back	688
313 X/DF	Single row taper roller bearing, paired face-to-face	682
31500	Single row inch taper roller bearing	644
3194(00) DA-2LS	Full complement double row cylindrical roller bearing with seals	598
32 A	Double row angular contact ball bearing	442
32 A-2RS1	Double row angular contact ball bearing with seals	446
32 A-2Z	Double row angular contact ball bearing with shields	446
320 X	Single row taper roller bearing	618
320 X/DB	Single row taper roller bearing, paired back-to-back	688
320 X/DF	Single row taper roller bearing, paired face-to-face	680
320 XR	Single row taper roller bearing with flanged outer ring	668
322	Single row taper roller bearing	618
322 B	Single row taper roller bearing	618
322/DB	Single row taper roller bearing, paired back-to-back	688
322/DF	Single row taper roller bearing, paired face-to-face	680
323	Single row taper roller bearing	618
323 B	Single row taper roller bearing	620
323 BR	Single row taper roller bearing with flanged outer ring	668
329	Single row taper roller bearing	628
329/DB	Single row taper roller bearing, paired back-to-back	690
329/DF	Single row taper roller bearing, paired face-to-face	684
33 A	Double row angular contact ball bearing	442
33 A-2RS1	Double row angular contact ball bearing with seals	446
33 A-2Z	Double row angular contact ball bearing with shields	446
33 D	Double row angular contact ball bearing with split inner ring	442
33 DNR	Double row angular contact ball bearing with snap ring groove and snap ring	442
330	Single row taper roller bearing	622
330/DB	Single row taper roller bearing, paired back-to-back	688
330/DF	Single row taper roller bearing, paired face-to-face	680
33000	Single row inch taper roller bearing	656
331	Single row taper roller bearing	620
331/DF	Single row taper roller bearing, paired face-to-face	680
331 R	Single row taper roller bearing with flanged outer ring	668
332	Single row taper roller bearing	618
332/DF	Single row taper roller bearing, paired back-to-back	682
33800	Single row inch taper roller bearing	654
3400	Single row inch taper roller bearing	646
3500	Single row inch taper roller bearing	648

Series or type designation	Product	Page
355	Single row inch taper roller bearing	652
3612(00) R	Single row cam roller	402
365	Single row inch taper roller bearing	652
36900	Single row inch taper roller bearing	660
3700	Single row inch taper roller bearing	652
37000	Single row inch taper roller bearing	660
385	Single row inch taper roller bearing	654
38800	Single row inch taper roller bearing	664
3900	Single row inch taper roller bearing	656
39500	Single row inch taper roller bearing	654
415	Single row inch taper roller bearing	646
42 A	Double row deep groove ball bearing	394
42600	Single row inch taper roller bearing	658
43 A	Double row deep groove ball bearing	394
4500	Single row inch taper roller bearing	652
455	Single row inch taper roller bearing	654
47400	Single row inch taper roller bearing	656
475	Single row inch taper roller bearing	656
47600	Single row inch taper roller bearing	658
47800	Single row inch taper roller bearing	658
48200	Single row inch taper roller bearing	660
511	Single direction thrust ball bearing	842
512	Single direction thrust ball bearing	842
513	Single direction thrust ball bearing	842
514	Single direction thrust ball bearing	842
522	Double direction thrust ball bearing	856
523	Double direction thrust ball bearing	856
524	Double direction thrust ball bearing	856
525	Single row inch taper roller bearing	648
53000	Single row inch taper roller bearing	650
532	Single direction thrust ball bearing	852
533	Single direction thrust ball bearing	852
534	Single direction thrust ball bearing	852
535	Single row inch taper roller bearing	650
542	Double direction thrust ball bearing	860
543	Double direction thrust ball bearing	860
544	Double direction thrust ball bearing	860
544000	Single row inch taper roller bearing	662
565	Single row inch taper roller bearing	656
575	Single row inch taper roller bearing	658
595	Single row inch taper roller bearing	658
60	Single row deep groove ball bearing	302
60 N	Single row deep groove ball bearing with snap ring groove	350
60 NR	Single row deep groove ball bearing with snap ring groove and snap ring	350
60-RSH	Single row deep groove ball bearing with seal	324
60-RSL	Single row deep groove ball bearing with seal	324
60-RS1	Single row deep groove ball bearing with seal	334
60-Z	Single row deep groove ball bearing with shield	324
60-ZNR	Single row deep groove ball bearing with shield, snap ring groove and snap ring	356
60-2RSH	Single row deep groove ball bearing with seals	324
60-2RSL	Single row deep groove ball bearing with seals	324
60-2RSL/HC5	Single row hybrid deep groove ball bearing with seals	904
60-2RS1	Single row deep groove ball bearing with seals	334
60-2RS1/HC5	Single row hybrid deep groove ball bearing with seals	906
60-2RZ	Single row deep groove ball bearing with seals	334
60-2RZ/HC5	Single row hybrid deep groove ball bearing with seals	904
60-2Z	Single row deep groove ball bearing with shields	324
60-2ZNR	Single row deep groove ball bearing with shields, snap ring groove and snap ring	356
60-2Z/VA201	Single row deep groove ball bearing for high temperatures with shields	930
60-2Z/VA208	Single row deep groove ball bearing for high temperatures with shields	930
60/HC5	Single row hybrid deep groove ball bearing	908
60/VA201	Single row deep groove ball bearing for high temperatures	930
618	Single row deep groove ball bearing	302
618-2RZ	Single row deep groove ball bearing with seals	330
618-2RS1	Single row deep groove ball bearing with seals	328
618-2Z	Single row deep groove ball bearing with shields	328
619	Single row deep groove ball bearing	302
619-2RZ	Single row deep groove ball bearing with seals	330
619-2RS1	Single row deep groove ball bearing with seals	326
619-2Z	Single row deep groove ball bearing with shields	324
62	Single row deep groove ball bearing	302

Product index

Series or type designation	Product	Page
62 N	Single row deep groove ball bearing with snap ring groove	350
62 NR	Single row deep groove ball bearing with snap ring groove and snap ring	350
62-RSH	Single row deep groove ball bearing with seal	324
62-RSL	Single row deep groove ball bearing with seal	324
62-RS1	Single row deep groove ball bearing with seal	334
62-Z	Single row deep groove ball bearing with shield	324
62-ZNR	Single row deep groove ball bearing with shield, snap ring groove and snap ring	356
62-2RSH	Single row deep groove ball bearing with seals	324
62-2RSL	Single row deep groove ball bearing with seals	324
62-2RSL/HC5	Single row hybrid deep groove ball bearing with seals	904
62-2RS1	Single row deep groove ball bearing with seals	334
62-2RS1/HC5	Single row hybrid deep groove ball bearing with seals	906
62-2RZ	Single row deep groove ball bearing with seals	334
62-2RZ/HC5	Single row hybrid deep groove ball bearing with seals	904
62-2Z	Single row deep groove ball bearing with shields	324
62-2ZNR	Single row deep groove ball bearing with shields, snap ring groove and snap ring	356
62-2Z/VA201	Single row deep groove ball bearing for high temperatures with shields	930
62-2Z/VA208	Single row deep groove ball bearing for high temperatures with shields	930
62-2Z/VA228	Single row deep groove ball bearing for high temperatures with shields	930
62/HC5	Single row hybrid deep groove ball bearing	908
62/VA201	Single row deep groove ball bearing for high temperatures	930
62/VL0241	INSOCOAT single row deep groove ball bearing	916
622-2RS1	Single row deep groove ball bearing with seals	328
623-2RS1	Single row deep groove ball bearing with seals	328
628-2Z	Single row deep groove ball bearing with shields	324
63	Single row deep groove ball bearing	302
63 N	Single row deep groove ball bearing with snap ring groove	350
63 NR	Single row deep groove ball bearing with snap ring groove and snap ring	350
63-RSH	Single row deep groove ball bearing with seal	328
63-RSL	Single row deep groove ball bearing with seal	328
63-RS1	Single row deep groove ball bearing with seal	324
63-Z	Single row deep groove ball bearing with shield	324
63-ZNR	Single row deep groove ball bearing with shield, snap ring groove and snap ring	356
63-2RSH	Single row deep groove ball bearing with seals	328
63-2RSL	Single row deep groove ball bearing with seals	328
63-2RS1	Single row deep groove ball bearing with seals	324
63-2RS1/HC5	Single row hybrid deep groove ball bearing with seals	904
63-2Z	Single row deep groove ball bearing with shields	324
63-2ZNR	Single row deep groove ball bearing with shields, snap ring groove and snap ring	356
63-2Z/VA201	Single row deep groove ball bearing for high temperatures with shields	930
63-2Z/VA208	Single row deep groove ball bearing for high temperatures with shields	930
63-2Z/VA228	Single row deep groove ball bearing for high temperatures with shields	930
63/HC5	Single row hybrid deep groove ball bearing	908
63/VA201	Single row deep groove ball bearing for high temperatures	930
63/VL0241	INSOCOAT single row deep groove ball bearing	916
63/VL2071	INSOCOAT single row deep groove ball bearing	916
630-2RS1	Single row deep groove ball bearing with seals	326
6300	Single row inch taper roller bearing	656
638-2Z	Single row deep groove ball bearing with shields	324
64	Single row deep groove ball bearing	304
64 N	Single row deep groove ball bearing with snap ring groove	350
64 NR	Single row deep groove ball bearing with snap ring groove and snap ring	350
64000	Single row inch taper roller bearing	660
649000	Single row inch taper roller bearing	666
65300	Single row inch taper roller bearing	652
655	Single row inch taper roller bearing	658
67300	Single row inch taper roller bearing	660
675	Single row inch taper roller bearing	658
67900	Single row inch taper roller bearing	662
68000	Single row inch taper roller bearing	660
72 B	Single row angular contact ball bearing	420
72000	Single row inch taper roller bearing	654
7225(00)	Flanged bearing housing	1066
73 B	Single row angular contact ball bearing	420
763000	Single row inch taper roller bearing	666
811	Cylindrical roller thrust bearing	870
812	Cylindrical roller thrust bearing	870
843000	Single row inch taper roller bearing	666
87000	Single row inch taper roller bearing	662
9200	Single row inch taper roller bearing	658
982	Single row deep groove ball bearing	304

Series or type designation	Product	Page
A 4000	Single row inch taper roller bearing	640
AH 3	Withdrawal sleeve	998
AH 23	Withdrawal sleeve	998
AH 30	Withdrawal sleeve	1000
AH 31	Withdrawal sleeve	1000
AH 32	Withdrawal sleeve	1000
AH 240	Withdrawal sleeve	999
AH 241	Withdrawal sleeve	999
AHX 3	Withdrawal sleeve	998
AHX 23	Withdrawal sleeve	998
AHX 30	Withdrawal sleeve	999
AHX 31	Withdrawal sleeve	998
AHX 32	Withdrawal sleeve	998
AOH 22	Withdrawal sleeve for oil injection	1001
AOH 23	Withdrawal sleeve for oil injection	1001
AOH 30	Withdrawal sleeve for oil injection	1001
AOH 31	Withdrawal sleeve for oil injection	1001
AOH 32	Withdrawal sleeve for oil injection	1001
AOH 240	Withdrawal sleeve for oil injection	1001
AOH 241	Withdrawal sleeve for oil injection	1001
AOHX 30	Withdrawal sleeve for oil injection	1003
AOHX 31	Withdrawal sleeve for oil injection	1003
AOHX 32	Withdrawal sleeve for oil injection	1003
ASNH 2	End cover for SNL plummer block housings	1052
ASNH 5	End cover for SNL plummer block housings	1038
BA	Single direction thrust ball bearing	842
BMB 62	Sensor-Bearing Unit	964
BSC-V	Full complement CARB toroidal roller bearing	802
BS2-22-2CS	Spherical roller bearing with seals	740
BS2-23-2CS	Spherical roller bearing with seals	740
C 22	CARB toroidal roller bearing	798
C 22 V	Full complement CARB toroidal roller bearing	798
C 23	CARB toroidal roller bearing	800
C 30	CARB toroidal roller bearing	802
C 30 V	Full complement CARB toroidal roller bearing	802
C 31	CARB toroidal roller bearing	802
C 31 V	Full complement CARB toroidal roller bearing	802
C 32	CARB toroidal roller bearing	802
C 39	CARB toroidal roller bearing	806
C 40	CARB toroidal roller bearing	798
C 40 V	Full complement CARB toroidal roller bearing	798
C 40-2CS5V	Sealed full complement CARB toroidal roller bearing	812
C 41	CARB toroidal roller bearing	808
C 41 V	Full complement CARB toroidal roller bearing	802
C 41-2CS5V	Sealed full complement CARB toroidal roller bearing	812
C 49 V	Full complement CARB toroidal roller bearing	798
C 50 V	Full complement CARB toroidal roller bearing	802
C 59 V	Full complement CARB toroidal roller bearing	798
C 59-2CS5V	Sealed full complement CARB toroidal roller bearing	812
C 60 V	Full complement CARB toroidal roller bearing	798
C 69 V	Full complement CARB toroidal roller bearing	798
C 69-2CS5V	Sealed full complement CARB toroidal roller bearing	812
FRB	Locating ring for bearing housings	1039
FY .. TF/VA201	Y- bearing flanged unit for high temperatures	938
FY .. TF/VA228	Y- bearing flanged unit for high temperatures	938
FYT .. TF/VA201	Y- bearing flanged unit for high temperatures	940
FYT .. TF/VA228	Y- bearing flanged unit for high temperatures	940
GS 811	Housing washer for cylindrical roller thrust bearings	871
GS 812	Housing washer for cylindrical roller thrust bearings	871
H 2	Adapter sleeve	980
H 3	Adapter sleeve	980
H 3 C	Adapter sleeve	980
H 3 E	Adapter sleeve	980
H 23	Adapter sleeve	980
H 30	Adapter sleeve	982
H 31	Adapter sleeve	982
H 39	Adapter sleeve	983
H 414200	Single row inch taper roller bearing	656
H 913800	Single row inch taper roller bearing	656

Product index

Series or type designation	Product	Page
HA 2	Adapter sleeve for inch shafts	988
HA 3	Adapter sleeve for inch shafts	988
HA 3 E	Adapter sleeve for inch shafts	988
HA 23	Adapter sleeve for inch shafts	988
HA 23 L	Adapter sleeve for inch shafts	991
HA 30	Adapter sleeve for inch shafts	991
HA 30 E	Adapter sleeve for inch shafts	991
HA 31	Adapter sleeve for inch shafts	991
HA 31 E	Adapter sleeve for inch shafts	992
HA 31 L	Adapter sleeve for inch shafts	991
HE 2	Adapter sleeve for inch shafts	988
HE 3	Adapter sleeve for inch shafts	988
HE 3 E	Adapter sleeve for inch shafts	988
HE 23	Adapter sleeve for inch shafts	988
HE 23 L	Adapter sleeve for inch shafts	992
HE 30	Adapter sleeve for inch shafts	992
HE 30 E	Adapter sleeve for inch shafts	992
HE 31	Adapter sleeve for inch shafts	991
HE 31 L	Adapter sleeve for inch shafts	992
HJ 2	Angle ring for cylindrical roller bearings	523
HJ 3	Angle ring for cylindrical roller bearings	523
HJ 4	Angle ring for cylindrical roller bearings	525
HJ 10	Angle ring for cylindrical roller bearings	535
HJ 22	Angle ring for cylindrical roller bearings	525
HJ 23	Angle ring for cylindrical roller bearings	525
HM 220100	Single row taper roller bearing	632
HM 231100	Single row inch taper roller bearing	660
HM 262700	Single row inch taper roller bearing	664
HM 266400	Single row inch taper roller bearing	664
HM 30	Lock nut	1014
HM 31	Lock nut	1014
HM 801300	Single row inch taper roller bearing	646
HM 803100	Single row inch taper roller bearing	648
HM 804800	Single row inch taper roller bearing	652
HM 807000	Single row inch taper roller bearing	650
HM 88500	Single row inch taper roller bearing	644
HM 88600	Single row inch taper roller bearing	644
HM 89400	Single row inch taper roller bearing	644
HM 903200	Single row inch taper roller bearing	650
HM 911200	Single row inch taper roller bearing	654
HME 30	Lock nut	1014
HS 2	Adapter sleeve for inch shafts	988
HS 3	Adapter sleeve for inch shafts	988
HS 3 E	Adapter sleeve for inch shafts	988
HS 23	Adapter sleeve for inch shafts	989
I-1200(00)	Flanged bearing housing for self-aligning ball bearings with extended inner ring	1065
ICOS-D1B	Deep groove ball bearing with radial shaft seal	348
JHM 720200	Single row taper roller bearing	632
JL 26700	Single row taper roller bearing	618
JL 69300	Single row taper roller bearing	620
JLM 104900	Single row taper roller bearing	622
JLM 508700	Single row taper roller bearing	624
JM 205100	Single row taper roller bearing	622
JM 511900	Single row taper roller bearing	626
JM 515600	Single row taper roller bearing	628
JM 714200	Single row taper roller bearing	628
JM 718100	Single row taper roller bearing	630
JM 738200	Single row taper roller bearing	636
K 811	Cylindrical roller and cage thrust assembly	871
K 812	Cylindrical roller and cage thrust assembly	871
KAM	Self-aligning ball bearing kit	472
KM	Lock nut	1012
KMFE	Lock nut	1023
KMK	Lock nut	1021
KML	Lock nut	1013
KMT	Lock nut	1026
KMTA	Lock nut	1028
L 183400	Single row inch taper roller bearing	662
L 327200	Single row inch taper roller bearing	660
L 357000	Single row inch taper roller bearing	664

Series or type designation	Product	Page
L 432300	Single row inch taper roller bearing	660
L 44600	Single row inch taper roller bearing	642
L 45400	Single row inch taper roller bearing	642
L 555200	Single row inch taper roller bearing	664
L 68100	Single row inch taper roller bearing	644
L 814700	Single row inch taper roller bearing	658
L 865500	Single row inch taper roller bearing	664
LL 483400	Single row inch taper roller bearing	666
LL 566800	Single row inch taper roller bearing	664
LL 639200	Single row inch taper roller bearing	662
LM 102900	Single row inch taper roller bearing	650
LM 104900	Single row inch taper roller bearing	652
LM 11700	Single row inch taper roller bearing	640
LM 11900	Single row inch taper roller bearing	640
LM 12700	Single row inch taper roller bearing	640
LM 241100	Single row inch taper roller bearing	662
LM 245800	Single row inch taper roller bearing	662
LM 283600	Single row inch taper roller bearing	666
LM 29700	Single row inch taper roller bearing	646
LM 300800	Single row inch taper roller bearing	646
LM 361600	Single row inch taper roller bearing	664
LM 377400	Single row inch taper roller bearing	666
LM 48500	Single row inch taper roller bearing	644
LM 501300	Single row inch taper roller bearing	648
LM 503300	Single row taper roller bearing	622
LM 567900	Single row inch taper roller bearing	664
LM 603000	Single row inch taper roller bearing	650
LM 67000	Single row inch taper roller bearing	644
LM 739700	Single row inch taper roller bearing	662
LM 742700	Single row inch taper roller bearing	662
LM 770900	Single row inch taper roller bearing	664
LM 772700	Single row inch taper roller bearing	664
LM 806600	Single row inch taper roller bearing	654
M 12600	Single row inch taper roller bearing	640
M 201000	Single row inch taper roller bearing	646
M 231600	Single row inch taper roller bearing	660
M 239400	Single row inch taper roller bearing	662
M 249700	Single row inch taper roller bearing	664
M 336900	Single row inch taper roller bearing	660
M 349500	Single row inch taper roller bearing	664
M 802000	Single row inch taper roller bearing	648
M 84500	Single row inch taper roller bearing	642
M 86600	Single row inch taper roller bearing	642
M 88000	Single row inch taper roller bearing	642
MB	Locking washer for lock nuts	1016
MBL	Locking washer for lock nuts	1016
MS 30	Locking clip for lock nuts	1014
MS 31	Locking clip for lock nuts	1014
N 2	Single row cylindrical roller bearing	522
N 3	Single row cylindrical roller bearing	522
NCF 18 V	Full complement single row cylindrical roller bearing	568
NCF 22 V	Full complement single row cylindrical roller bearing	566
NCF 28 V	Full complement single row cylindrical roller bearing	570
NCF 29 V	Full complement single row cylindrical roller bearing	564
NCF 30 V	Full complement single row cylindrical roller bearing	564
NJ 10	Single row cylindrical roller bearing	536
NJ 2	Single row cylindrical roller bearing	522
NJ 22	Single row cylindrical roller bearing	522
NJ 23	Single row cylindrical roller bearing	522
NJ 3	Single row cylindrical roller bearing	522
NJ 4	Single row cylindrical roller bearing	524
NJG 23 VH	Full complement single row cylindrical roller bearing	564
NNC 48 CV	Full complement double row cylindrical roller bearing	586
NNC 49 CV	Full complement double row cylindrical roller bearing	584
NNCF 48 CV	Full complement double row cylindrical roller bearing	586
NNCF 49 CV	Full complement double row cylindrical roller bearing	584
NNCF 50 CV	Full complement double row cylindrical roller bearing	584
NNCL 48 CV	Full complement double row cylindrical roller bearing	586
NNCL 49 CV	Full complement double row cylindrical roller bearing	584
NNF 50 ADA-2LSV	Full complement double row cylindrical roller bearing with seals	596
NU 10	Single row cylindrical roller bearing	522
NU 12	Single row cylindrical roller bearing	556

Product index

Series or type designation	Product	Page
NU 2	Single row cylindrical roller bearing	522
NU 2/VL0241	INSOCOAT single row cylindrical roller bearing	918
NU 20	Single row cylindrical roller bearing	556
NU 22	Single row cylindrical roller bearing	522
NU 23	Single row cylindrical roller bearing	522
NU 3	Single row cylindrical roller bearing	522
NU 3/VL0241	INSOCOAT single row cylindrical roller bearing	918
NU 4	Single row cylindrical roller bearing	524
NUP 2	Single row cylindrical roller bearing	522
NUP 22	Single row cylindrical roller bearing	522
NUP 23	Single row cylindrical roller bearing	522
NUP 3	Single row cylindrical roller bearing	522
OH 23 H	Adapter sleeve for oil injection	984
OH 30 H	Adapter sleeve for oil injection	984
OH 31 H	Adapter sleeve for oil injection	984
OH 31 HTL	Adapter sleeve for oil injection	984
OH 32 H	Adapter sleeve for oil injection	984
OH 39 H	Adapter sleeve for oil injection	984
OH 39 HE	Adapter sleeve for oil injection	985
QJ 2	Four-point contact ball bearing	456
QJ 3	Four-point contact ball bearing	456
SAF	Pillow (plummer) block housing for inch shafts	1061
SBD	Large plummer block housing	1063
SDAF	Pillow (plummer) block housing for inch shafts	1062
SDG	Large plummer block housing	1060
SNL 2	Plummer block housing for bearings with cylindrical bore	1048
SNL 3	Plummer block housing for bearings with cylindrical bore	1048
SNL 30	Large plummer block housing	1054
SNL 31	Large plummer block housing	1054
SNL 5	Plummer block housing for bearings on adapter sleeve	1038
SNL 6	Plummer block housing for bearings on adapter sleeve	1038
SONL	Plummer block housing for oil lubrication	1059
SP	Snap ring	350
SY .. TF/VA201	Y-bearing plummer block unit for high temperatures	936
SY .. TF/VA228	Y-bearing plummer block unit for high temperatures	936
THD	Take-up bearing housing	1067
TSN 2 A	V-ring seal for plummer block housings	1048
TSN 2 G	Double-lip seal for plummer block housings	1048
TSN 2 ND	Taconite-seal for plummer block housings	1048
TSN 2 S	Labyrinth seal for plummer block housings	1048
TSN 3 A	V-ring seal for plummer block housings	1048
TSN 3 G	Double-lip seal for plummer block housings	1048
TSN 3 ND	Taconite-seal for plummer block housings	1048
TSN 3 S	Labyrinth seal for plummer block housings	1048
TSN 5 A	V-ring seal for plummer block housings	1038
TSN 5 G	Double-lip seal for plummer block housings	1038
TSN 5 L	Four-lip seal for plummer block housings	1038
TSN 5 ND	Taconite-seal for plummer block housings	1038
TSN 5 S	Labyrinth seal for plummer block housings	1038
TSN 6 A	V-ring seal for plummer block housings	1038
TSN 6 G	Double-lip seal for plummer block housings	1038
TSN 6 ND	Taconite-seal for plummer block housings	1038
TSN 6 S	Labyrinth seal for plummer block housings	1038
TN	Plummer block housing for self-aligning ball bearings with extended inner ring	1065
TVN	Plummer block housing	1064
T2DC	Single row taper roller bearing	636
T2DD	Single row taper roller bearing	626
T2ED	Single row taper roller bearing	622
T2EE	Single row taper roller bearing	620
T3FE	Single row taper roller bearing	628
T4CB	Single row taper roller bearing	632
T4DB	Single row taper roller bearing	634
T4EB	Single row taper roller bearing	638
T4EE	Single row taper roller bearing	636
T7FC	Single row taper roller bearing	622
T7FC/DT	Single row taper roller bearing, paired in tandem	692
U 2	Seating ring for thrust ball bearings	852
U 3	Seating ring for thrust ball bearings	852
U 4	Seating ring for thrust ball bearings	852

Series or type designation	Product	Page
W 60	Stainless steel single row deep groove ball bearing	378
W 60-2RS1	Stainless steel single row deep groove ball bearing with seals	382
W 60-2Z	Stainless steel single row deep groove ball bearing with shields	382
W 617	Stainless steel single row deep groove ball bearing	378
W 618	Stainless steel single row deep groove ball bearing	378
W 618-2Z	Stainless steel single row deep groove ball bearing with shields	384
W 619	Stainless steel single row deep groove ball bearing	378
W 619-2RS1	Stainless steel single row deep groove ball bearing with seals	384
W 619-2Z	Stainless steel single row deep groove ball bearing with shields	382
W 62	Stainless steel single row deep groove ball bearing	378
W 62-2RS1	Stainless steel single row deep groove ball bearing with seals	382
W 62-2Z	Stainless steel single row deep groove ball bearing with shields	382
W 627-2Z	Stainless steel single row deep groove ball bearing with shields	382
W 628-2Z	Stainless steel single row deep groove ball bearing with shields	382
W 63	Stainless steel single row deep groove ball bearing	378
W 63-2RS1	Stainless steel single row deep groove ball bearing with seals	384
W 63-2Z	Stainless steel single row deep groove ball bearing with shields	382
W 637-2Z	Stainless steel single row deep groove ball bearing with shields	382
W 638-2Z	Stainless steel single row deep groove ball bearing with shields	382
W 639-2Z	Stainless steel single row deep groove ball bearing with shields	382
WS 811	Shaft washer for cylindrical roller thrust bearings	871
WS 812	Shaft washer for cylindrical roller thrust bearings	871
YAR-2FW/VA201	Y-bearing with grub screw locking for high temperatures	934
YAR-2FW/VA228	Y-bearing with grub screw locking for high temperatures	934

