



*Designed for Wastewater Professionals*  
*Fast Results. Ruggedly Reliable.*

# Product Catalog



Corporate Office:  
Mailing Address:  
321-914-0722

2412 Irwin St. #9 Melbourne, FL 32901  
870 N. Miramar Ave. Indialantic, FL 32903  
[www.kationx.com](http://www.kationx.com)



*Designed for Wastewater Professionals  
Fast Results. Ruggedly Reliable.*

# Table of Contents

About Kationx: .....	2
Product Map: .....	3
<b>Fog Control Products:</b>	
FOGMVR™ .....	4
ShrinkNFOG™ .....	5
PLMMRS HLPR™ .....	6
FOGBSTR™ Jetting Skid™ .....	7
FOGBSTR™ Jetting Rig™ .....	8
<b>ODOR, H2S, &amp; Corrosion Control Products:</b>	
ODR&FOG™ -- All in one collections cleaner.....	9
BoostR™ - Heavy duty reactive molecule scavenging/removal.	10
<b>Treatment Plant:</b>	
SETTApHY™ - Flocculant.....	11
LiquidSETTApHY – Pumpable floc in a 275 – Gal tote.....	12
SuperSETTApHY – Flocculant + odor control.....	13
<b>Retail / Consumer Products:</b>	
GasKat™ - Bathroom & toilet/head odor control.....	14
WypKLN-PRO™ - Non-toxic waterless hand degreaser for mechanics.....	15
Our Distributors.....	16



*Designed for Wastewater Professionals  
Fast Results. Ruggedly Reliable.*

## About KationX™ History

Since 2018, KationX products have consistently proven their **GREEN, BEST-VALUE** proposition. Our customers have (1) achieved compliance, (2) reduced or eliminated fines, and (3) “found money” inside their budgets by reducing both direct & indirect costs. Infrastructure lives longer while our customers work smarter, not harder. We reduce CAPEX across the board by delivering simplicity, safety, and good quality influent & effluent. KationX Corp is a Veteran owned & operated Small Business (CAGE 84p00).

### Product Design Concept

- ✓ **Green, Non-toxic**, solutions
- ✓ **Safety & Simplicity** are paramount
- ✓ **Non-reactive Chemistries**. No new molecules.
- ✓ **Minimal Environmental Impact**
- ✓ **Made in USA** using a **US-ONLY** Supply Chain.

### What we Know

- ✓ KationX Products are **Ruggedly Reliable. Perform on Demand.**
- ✓ Consistently deliver **Immediately Observable Results.**
- ✓ **Best Value** saving money, time, & other direct + indirect costs.
- ✓ **Simple & Easy to Use.** Intuitive & Safe.
- ✓ **Use enough** to get the results you want. Don't use too little.
- ✓ **Routine Use = Persistent Presence.** Initial problems recede.
- ✓ Over time, **Customers use less product** to maintain same results.
- ✓ **Durable. Long shelf lives.** Store Powders outdoors or on the truck.



*Designed for Wastewater Professionals  
Fast Results. Ruggedly Reliable.*

# Kationx Product Map

Sinks  
Toilets  
Kitchen  
Lines

Lift Stations (LS)  
Manholes  
Lines  
Master Lift Stations

**PLMMRS HLPR**

**FOGMVR:** FOG Mobilization.  
**ShrinkNFOG:** FOG elimination.  
**ODR&FOG:** All-in-one sewer treatment.  
**BoostR:** For serious gas & vapor control.  
**FOGBSTR Jetting Skid:** Collection System Cleaning.  
**FOGBSTR Jetting Rig:** Complex cleaning jobs.

Wastewater Collections Upstream

Downstream



Wastewater Treatment (& Package) Plants

**FOG Foam**

**Settling**

**Clarifier Polishing**

**Digester Settling**

**FOGMVR**  
**ShrinkNFOG**  
**SETTApHY**  
**FOGBSTR Jetting Rig**  
To mix products & jet.

**SETTApHY powder:** On-Demand Settling.  
**LiquidSETTApHY:** Automated Dosing.  
**SuperSETTApHY:** Odor Control.  
  
Reduce nutrient loading.  
Reduce chlorine usage.  
Compliant discharged effluent.  
Treatment plant odor control.



[www.kationx.com](http://www.kationx.com)



*Designed for Wastewater Professionals  
Fast Results. Ruggedly Reliable.*

# FOGMVR™

Cleans Collections Infrastructure  
Increases life span for equipment & facilities  
Cleaning & Vac-Truck jobs go faster.  
Solids become unstuck & free floating.  
No mopheads. Solids removal is easier!

## Features & Benefits:

- ✓ Emulsifies FOG (with jetted water).
- ✓ Ruggedly Reliable Results.
- ✓ Aggressive Jetting to form Slurry.
- ✓ Keeps Cleaning Downstream
- ✓ Safe, Simple & Easy to Use.
- ✓ Inexpensive.
- ✓ Non-Corrosive.
- ✓ Non-Toxic.
- ✓ Skin & Eye Safe.
- ✓ Unlimited Shelf life.
- ✓ 100% Active Ingredients.
- ✓ US-ONLY materials. Made in USA.



**FOGMVR™ 5 Gal. Bucket**  
**Kationx™ Product**  
**Weight: 25 lbs.**  
**Condition: New**  
**\$150.00 ea. Not including shipping**

Questions?  
Call 321-914-0722  
[Info@Kationx.com](mailto:Info@Kationx.com)



**NOTE:** FOGMVR can be used on leaked spills to consolidate escaped wastewater biosolids. Adding FOGMVR forms an Effective matrix that's easy to clean up (and FOGMVR won't kill the grass!)



*Designed for Wastewater Professionals  
Fast Results. Ruggedly Reliable.*

# ShrinkNFOG™

A powerful, all-natural, lift station cleaner that consumes (eats) & eliminates FOG.

## Benefits:

- ✓ Fast & Efficient.
- ✓ Simple & Easy to Use
- ✓ No site prep required.
- ✓ Best Results – Apply After Jetting
- ✓ Cleans Collections Infrastructure.
- ✓ Increases Infrastructure lifespan
- ✓ Smaller to No FOG Mats
- ✓ ZERO FOG = free-floating rags...
- ✓ Easier to Vac-out.
- ✓ US-ONLY Materials. Made in USA.



**ShrinkNFOG™ 2.5 Gal. Jug**

**Kationx™ Product**

**Weight: 20 lbs.**

**Condition: New**

**\$190.00 ea. Not including shipping**

**Questions?**

**Call 321-914-0722**

**[Info@Kationx.com](mailto:Info@Kationx.com)**



**ShrinkNFOG:** Expands by 48+ generations every 24 hrs. consumes/eliminates FOG.

**FOG:** Slurry creates massive surface area for bugs to attack & eat. 50% FOG reduction in just 2-3 days. Treat weekly or bi-weekly to achieve & maintain a **FOG-free** collection system.



*Designed for Wastewater Professionals  
Fast Results. Ruggedly Reliable.*

# PLMMRS HLPR™

The BEST VALUE, environmentally-friendly, solution for commercial plumbers, janitors, and property management firms. Designed to specifically tackle fats, oils, & grease (FOG). To clear line clogs, **PLMMRS HLPR™** is your first go-to tool. Use routinely to maintain clean & clear lines & drains.

## Users Include

- ✓ Plumbers.
- ✓ Janitorial Services.
- ✓ School Systems.
- ✓ Maintenance Techs.
- ✓ Zoo's & Animal Control Facilities.

## Benefits

- ✓ Fast results - get more done in a day.
- ✓ Clears FOG from drain lines.
- ✓ SAFE, Simple & Easy to Use
- ✓ Cafeteria Drain & Line Cleaning.
- ✓ Kid, Food, & Animal Safe. Non-toxic.
- ✓ 100% Active Ingredients. No fillers.
- ✓ Made in USA. US-ONLY materials.
- ✓ Unlimited shelf life.



**PLMMRS HLPR™ 5 Gal. Bucket**

**Kationx™ Product**

**Weight: 25 lbs.**

**Condition: New**

**\$190.00 ea. Not including shipping**

Questions?

Call 321-914-0722

[Info@Kationx.com](mailto:Info@Kationx.com)



www.kationx.com



# FOGBSTR JETTING SKID™

- ✓ Give Operators Jetting Capabilities. Anywhere. On-site, On-demand.
- ✓ Use your existing fleet – **any pick-up truck becomes a jetting unit.**
- ✓ Clean & Clear Problems (FOG Mats) when encountered.
- ✓ Minimize costs & outside resources.
- ✓ Maximize your team; Enhance capabilities.
- ✓ Simplify your day.

## FOGBSTR JETTING SKID

Kationx™ Product

Weight: 680 lbs. empty  
3190 lbs. full

Condition: New

\$22,500 ea. Not including shipping

Questions?

Call 321-914-0722

[Info@Kationx.com](mailto:Info@Kationx.com)

## Capabilities

Fits F-150 or larger beds

Conformable fit inside wheel wells

Ready to Work! Includes all equipment, tools, and accessories

Simple & Intuitive to Operate

200-gal fill = F-150 wt. capacity. Larger trucks can carry 300-gal load.

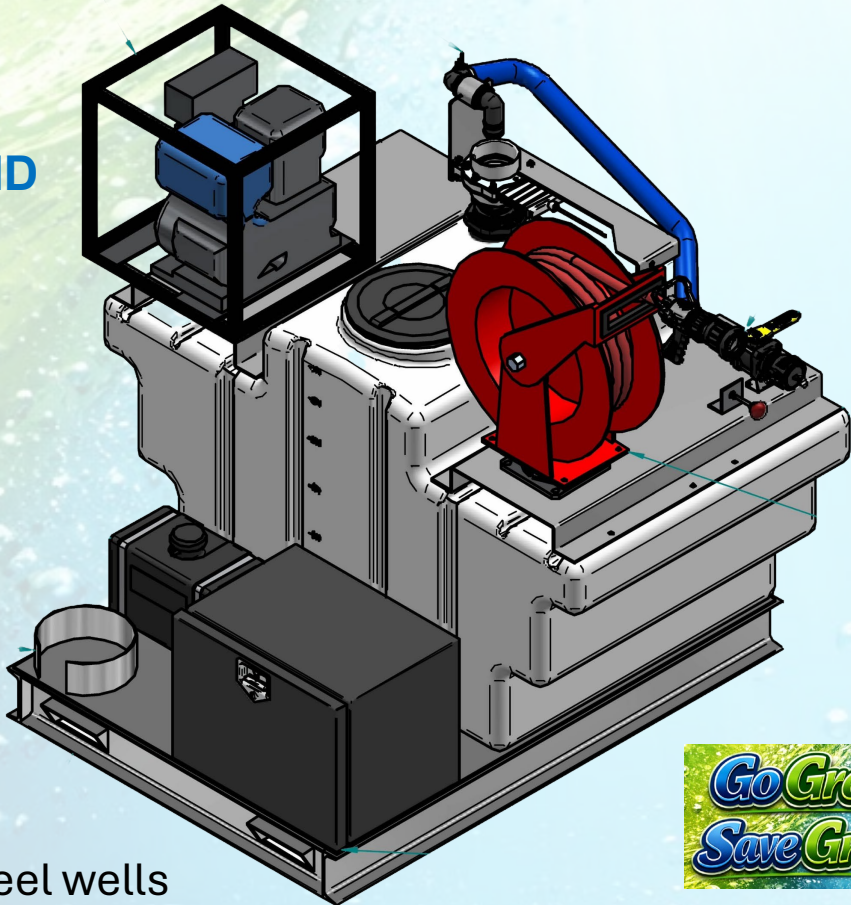

*Designed for Wastewater Professionals  
Fast Results. Ruggedly Reliable.*





Air Gap

325-Gallon Tank

Toolbox

2-Axels = Better Stability

Trash Pumps

Trailer

Heavy Duty Fenders

Hydrant Loading



## Kationx™ FOGBSTR Trailer

**FOGBSTR Trailer™**  
**Kationx™ Product**  
**325-gal tank w 2 pumps & tools**  
**Condition: New**  
**\$42,500** ea. Not including shipping  
**Job Ready – includes tools, hoses, & fittings**

Questions?  
 Call 321-914-0722  
[Info@Kationx.com](mailto:Info@Kationx.com)

- ✓ Enables jetting Kationx Product mixes
- ✓ Turn-key Ready-to-Work Package
- ✓ Jetting Pump + Recirculating Pump
- ✓ Dedicated Water Loading Line
- ✓ Rugged, 2-axle, Construction. Tows & Tracks Smoothly!
- ✓ Two Hatches assures continuous operations for large jobs.
- ✓ Non-skid Surfaces. Ergonomic.
- ✓ Perfect for Master Lift Station, Bar Screen, FOG Foam, & FOG Clog cleanouts.



*Designed for Wastewater Professionals*  
*Fast Results. Ruggedly Reliable.*



# ODR&FOG™

Our **premium**, all-in-one, **Best Value**, all-natural, environmentally friendly, non-toxic turn-key sewer treatment Product! Removes **H<sub>2</sub>S**, **VOCs** & **Odors**. Reduces corrosion. Improves Infrastructure longevity!



- ✓ Green, **non-toxic**, non-corrosive.
- ✓ All natural. No synthetics.
- ✓ 100% Active Ingredients. No diluents or fillers.
- ✓ Safe, Simple, & Easy to Handle.
- ✓ Ruggedly reliable, Consistent Results.
- ✓ WW Chemistry or Temp won't matter.
- ✓ Treats both AIR & WATER phases inside infrastructure
- ✓ Longer Lived Infrastructure
- ✓ Reduce COSTS, complexity, and risks.
- ✓ Improve operational performance
- ✓ Greener/Cleaner influent arrives at plant.
- ✓ Unlimited shelf life.
- ✓ Made in the USA.
- ✓ 100% Active ingredients.

## ODR&FOG™ 5 Gal. Bucket

**Kationx™ Product**

**Weight: 25 lbs.**

**Condition: New**

**\$190.00 ea. Not including shipping**

Questions?

Call 321-914-0722

[Info@Kationx.com](mailto:Info@Kationx.com)



*Designed for Wastewater Professionals*  
*Fast Results. Ruggedly Reliable.*





*Designed for Wastewater Professionals  
Fast Results. Ruggedly Reliable.*

# BoostR™

**BoostR** delivers **on-demand scavenging** to reduce & remove **H<sub>2</sub>S, VOCs, Odors** and other dangerous, corrosive, flammable, toxic, & aggressively reactive molecules from both AIR + Water phases inside sewer infrastructure. Becomes persistent with regular use.

## Benefits include:

- ✓ Removes **H<sub>2</sub>S, CO, VOCs, Odors**, other **reactive gases & vapors.**
- ✓ Corrosion control.
- ✓ On-demand performance. Works immediately
- ✓ Operator **SAFE!** Safe for micro-flora & -fauna.
- ✓ Simple & Easy to handle.
- ✓ Use for Confined Space Entry.
- ✓ Lowers costs! Saves time.
- ✓ Unlimited shelf life.
- ✓ 100% Active Ingredients
- ✓ **US-ONLY** materials. Made in USA.



## BoostR™ 5 Gal. Bucket

**Kationx™ Product**

**Weight: 25 lbs.**

**Condition: New**

**\$190.00 ea. Not including shipping**

**Need Help? Call 321-914-0722**

Hydrogen Sulfide: (**BoostR** removes this)  
Colorless gas; Rotten-egg smell. Irritates eyes/skin & respiratory tract. Poisonous! Inhalation causes headache, dizziness, nausea. High levels(>1000 ppm) can be instantly fatal –causes respiratory paralysis; Attacks nervous system. Cardiac effects may occur. Highly flammable & Explosion hazard.



# SETTApHY™



*Designed for Wastewater Professionals  
Fast Results. Ruggedly Reliable.*

A natural, non-toxic, non-corrosive, skin & eye safe, ruggedly reliable flocculant that delivers on-demand **biosolids & digester sludge settling** plus **clarifier polishing**. SETTApHY customers save significant costs while reducing complexity, risks, and plant upsets.

## Benefits.

- ✓ On-Demand Settling and Clarifier Polishing.
- ✓ Immediately observable results
- ✓ Safe, simple & easy to use. No additives.
- ✓ Effectively unlimited shelf life.
- ✓ No special handling. Store outdoors. Rugged.
- ✓ All natural ingredients. No Synthetics.
- ✓ Non-corrosive, non-toxic, non-flammable
- ✓ Made in USA with US-ONLY material



**SETTApHY™ 5 Gal. Bucket**  
**Kationx™ Product**  
**Weight: 25 lbs.**  
**Condition: New**  
**\$150.00 ea. Not including shipping**

Questions?  
 Call 321-914-0722  
[info@Kationx.com](mailto:info@Kationx.com)

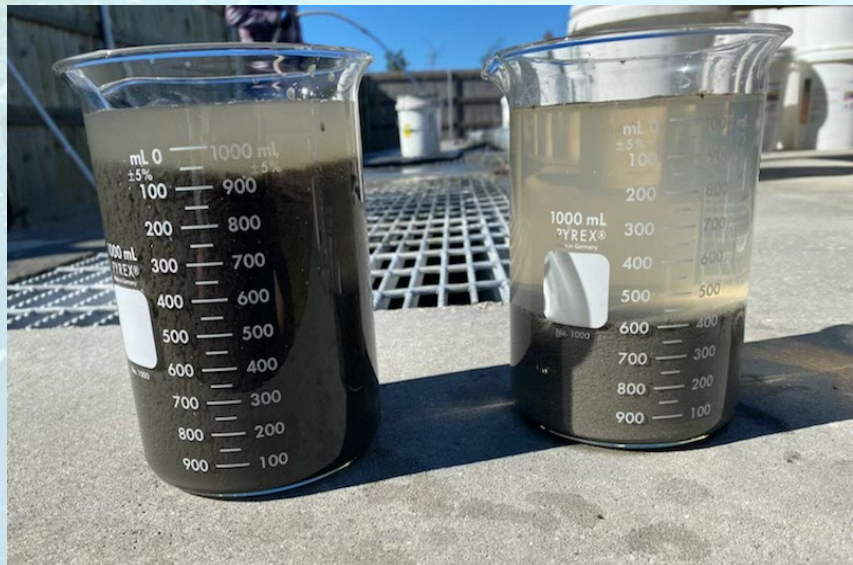

[www.kationx.com](http://www.kationx.com)

# Liquid SETTApHY™

Replaces liquid alum, ferric, & polymer products with a superior, natural, **liquid flocculant**. Perfect for automated dosing to settle biosolids & sludge plus midge control. Store outdoors, in sunlight...rugged with no effective shelf life. Non-toxic, non-corrosive, skin & eye safe. Best Value – hands down!

- ✓ Clean & Clear Supernatant.
- ✓ Clarifier Polishing.
- ✓ Sludge & Biosolids Settling.
- ✓ Improves Dewatering & Belt Pressing.
- ✓ Pumps like liquid coagulants & flocs.
- ✓ No process changes required at plant
- ✓ Easy Chem-Loc Fittings.
- ✓ 100% Active Ingredients
- ✓ Mix & Stir with Paddle before Using.
- ✓ Won't Age-out or Expire. Just Resuspend!
- ✓ Non-toxic. Non-corrosive. Skin & Eye Safe.
- ✓ Won't upset Plant or Harm Microecology.



## Reduce or eliminate :

- Expensive & Finicky Polymers
- Additives
- Mixing, Prep, Pump Maintenance.
- HAZMAT Disposal Costs
- Shelf-life Expiration

**WINTER USE:** Keep Liquid SETTApHY in suspended in emulsion to lower freezing point. In freezing temperatures mix every afternoon. To prevent an ice layer from Forming, store totes indoors.

**Liquid SETTApHY™ 275 Gal. Tote**  
**Kationx™ Product**

**Weight: 2700 lbs. Built-in Skid.**  
**Condition: New**

**\$1700.00 ea. Not including shipping**

Questions?

Call 321-914-0722

Info@Kationx.com



*Designed for Wastewater Professionals*  
*Fast Results. Ruggedly Reliable.*



[www.kationx.com](http://www.kationx.com)



# SuperSETTApHY™

Our premium, all-in-one, wastewater treatment plant treatment...  
Delivers ruggedly reliable, on-demand, performance by settling  
Biosolids & digester sludge and removing odors, reactive gases  
& vapors from aeration basins, clarifiers, digester, and package plants

## Achieves:

- ✓ Biosolids & Digester Settling.
- ✓ Clarifier Polishing
- ✓ **Odor & Corrosion Control.**
- ✓ Stable WWTF Microecology.

## Lowers/Removes:

- ✓ Odors.
- ✓ H<sub>2</sub>S & VOCs...
- ✓ Supernatant Nutrient Loading.
- ✓ Chlorine Usage.

## Benefits:

- ✓ Natural Flocculant.
- ✓ Eliminates Odors
- ✓ On-Demand Performance.
- ✓ Immediately Observable Results.
- ✓ Inexpensive. Lowers Costs.
- ✓ Non-Corrosive. Non-Flammable
- ✓ Non-Toxic
- ✓ No additives or Special Handling
- ✓ Won't affect pH or upset Plant
- ✓ Skin & Eye Safe. Operator Safe!
- ✓ Effectively Unlimited Shelf Life



**SuperSETTApHY™ 5 Gal. Bucket**  
**Kationx™ Product**  
**Weight: 25 lbs.**

**Condition: New**

**\$190.00 ea. Not including shipping**

**Questions?**

**Call 321-914-0722**

**[Info@Kationx.com](mailto:Info@Kationx.com)**



[www.kationx.com](http://www.kationx.com)



*Designed for Wastewater Professionals*  
*Fast Results. Ruggedly Reliable.*





*Designed for Wastewater Professionals  
Fast Results. Ruggedly Reliable.*

# GasKat™

## Bathroom, Latrine, & Toilet Odor Remover.

**Removes foul, noxious odors from Toilets, Latrines, RV & Boat Heads, Port-A Johns, Public-Use Bathrooms, Field Trenches, Outhouses, Mobile Homes, Barracks, & other high-use bathroom facilities. Regular, routine use will eliminate prevailing stink. Physically scavenges (removes) offending odor molecules. No fragrance. No synthetics. Non-toxic. Skin & Eye Safe!**

### Instructions:

**For toilets,** (1) shake the bottle to loosen powder. Then (2) hold about 4" over the opening or water surface. (3) Puff twice onto the water and (4) flush.

**For latrines,** 4-5 puffs into each opening or continue puffs until odor disappears. Repeat every 2-3 hours during latrine use.

- ✓ REMOVES odors.
- ✓ **Not a fragrance** (these just mask & add breathed chemicals!). NOTE: Other odor removers are **mostly water**.
- ✓ Works in both AIR + WATER phases inside the bowel, drains, & holding tanks.
- ✓ Also **Cleans Lines & Pipes**. Routine Use cleans entire system.
- ✓ **100% Active Ingredients**. No fillers or diluents!
- ✓ Designed for our Military by U.S. Military Veterans.



**GasKat™ 16 oz. Bottle**

**Kationx™ Product**

**12 Bottles per Case**

**\$23.99 ea. Not including shipping**

Questions?

Call 321-914-0722

[Info@Kationx.com](mailto:Info@Kationx.com)





*Designed for Wastewater Professionals  
Fast Results. Ruggedly Reliable.*

# WYPKLN-PRO™

**Non-toxic hand degreaser. Designed for professionals!**

## **New Product Launch – Spring '26**

- ✓ Designed for mechanics working in austere environments, downrange, in-field, on-site.
- ✓ Can be used without water; no sink needed.
- ✓ Non-toxic formulation. Inert. Not a HAZMAT.
- ✓ **All-natural formulation.** NO synthetics.
- ✓ Safe, Simple, & Easy to Use.
- ✓ **100% active Ingredients,** No diluents or fillers.

**WYPKLN-PRO** cuts through and removes grease, grime, oils, and tough industrial soils while remaining gentle on skin. Ideal for repeated daily use in tactical, remote, industrial, automotive, marine, wastewater, & other commercial MRO settings. **Just apply paste to hands; then rub** until grease, oil, and crud flakes off. No after-smell or fragrance. Reduces petroleum smells on hands.

### **Key Benefits include:**

- ✓ Removes grease, grime, oils, and heavy soils. Can use without a water rinse.
- ✓ Safe for skin. Non-irritating.
- ✓ Environmentally friendly and biodegradable.
- ✓ Trusted Kationx™ quality for profession use.
- ✓ Designed by Veterans for Veterans & Military Maintainers



**WYPKLN-Pro**  
**Kationx™ Product**

**Weight: 2.75 lbs.**

**Condition: New**

**\$.00 ea. Not including shipping**

Questions?

Call 321-914-0722

[Info@Kationx.com](mailto:Info@Kationx.com)



## Distributed By:



WATER &  
WASTEWATER  
SPECIALISTS



Distributed by



**ECO H2O**

RECYCLE REMEDIATE REUSE

*You can also buy our Retail Products at:*



Walmart



## Our Expertise

**Kationx™** green & clean technology is proving disruptive in its performance and best-value proposition.– a market dominated by HAZMATs. **Kationx** provides safe, simple, and easy to use products that FIX common wastewater problems. **Kationx** delivers a practical - yet out-of-the-box - set of products, skills, experience & insights that improve performance while reducing costs, complexity, and risks. Ever-growing **Kationx** continues to find new applications for its Green Tech taking us into new markets & industries.