

Hyundai Warehouse Equipment

Electric Pallet truck, Electric Stacker and Manual Hand Pallet Truck

MOVING YOU FURTHER

HYUNDAI CONSTRUCTION EQUIPMENT



■ photo may include optional equipment.

▲ HYUNDAI CONSTRUCTION EQUIPMENT

PLEASE CONTACT

55, bundang-ro, Bundang-gu, Seongnam-si, Gyeonggi-do, Korea
Flat No. 2, Plot No. 35 ,
Wellington Road, Beside Club View Hotel
Secunderabad, Telangana- 500009
Tel: +91 40 48511339 , Fax: +9140 40037280
Email : sales@rsgmhe.com , Web: www.rsgmhe.com



R S GLOBAL

Hyundai-MHE/ Forklifts Authorized Dealer

www.hyundai-ce.com

2017. 03 Rev. 2

HYUNDAI
CONSTRUCTION EQUIPMENT

Electric Pallet truck

15/18/20EP



■ photo may include optional equipment.

Standard Configurations

15EP

- Lifting Capacity : 1,500kg
- DC Brushless Drive Motor 0.9kW
- Lifting Motor : 0.8kW
- Drive Wheel : Φ 195x70mm
- Double Fork wheel : Φ 80x70mm
- Hourmeter, Battery Discharge Indicator (BDI) & lift cut off
- Overall Fork Width x Length : 550mm x 1,150mm
- Turtle mode switch
- Built-in Charger
- Curtis Tiller with Convenient Control buttons
- Emergency switch
- Belly switch

18EP

- Lifting Capacity : 1,800kg
- AC Drive Motor 1.2kW
- Lift motor 1.2kW
- Curtis controller
- Drive wheel : Φ 250x70mm
- Double Fork wheel : Φ 80x70mm
- Hourmeter, Battery Discharge Indicator (BDI) & lift cut off
- Overall Fork Width x Length : 550mm x 1,150mm
- Turtle mode switch
- Curtis Tiller with Convenient Control buttons
- Side Battery Removal
- Emergency switch
- Belly switch

20EP

- Lifting Capacity : 2,000kg
- AC Drive Motor 1.2kW
- Lift motor 1.2kW
- Curtis controller
- Drive wheel : Φ 250x70mm
- Double Fork wheel : Φ 82x98mm
- Hourmeter, Battery Discharge Indicator (BDI) & lift cut off
- Overall Fork Width x Length : 550mm x 1,150mm
- Turtle mode switch
- Curtis Tiller with Convenient Control buttons
- Side Battery Removal
- Emergency switch
- Belly switch

Advantages

SAFETY AND PRODUCTIVITY

- Advanced AC control system eliminates directional contactors, which brings minimal maintenance requirements. (18/20EP Only)
- Intelligent regenerative brake system: increase overall truck performance.
- Side-way battery with roll-out system. (18/20EP Only)
- Emergency switch.
- Turtle mode switch
- Proportional Travel speed control.
- Belly switch.

STRUCTURAL

- The motor structure is water-proof and dust-proof(IP 44)
- Spring-loaded castors improve lateral stability on uneven floors and enhance truck performance and service life.
- Welded type fork

SERVICEABILITY

- CANbus technology reduces wiring complexity.
- All pivot points have grease fitting and serviceable to reduce component-wearing

Tiller Head



Curtis Tiller with convenient control buttons (standard)



Germany Frei Tiller (option)

Dimension

15EP

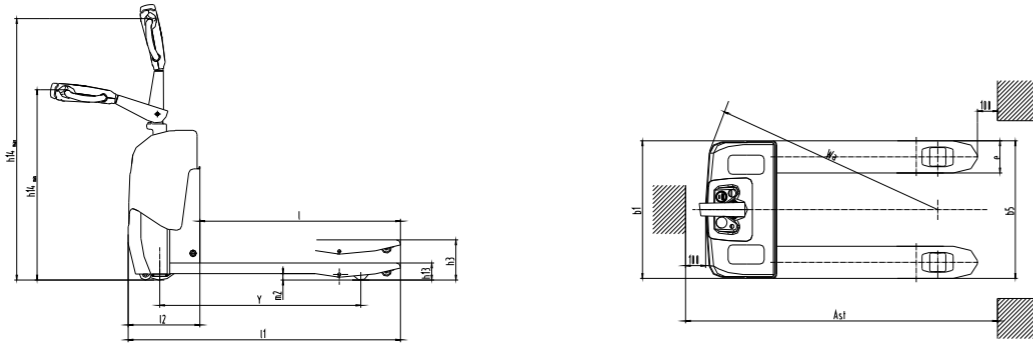

18/20EP

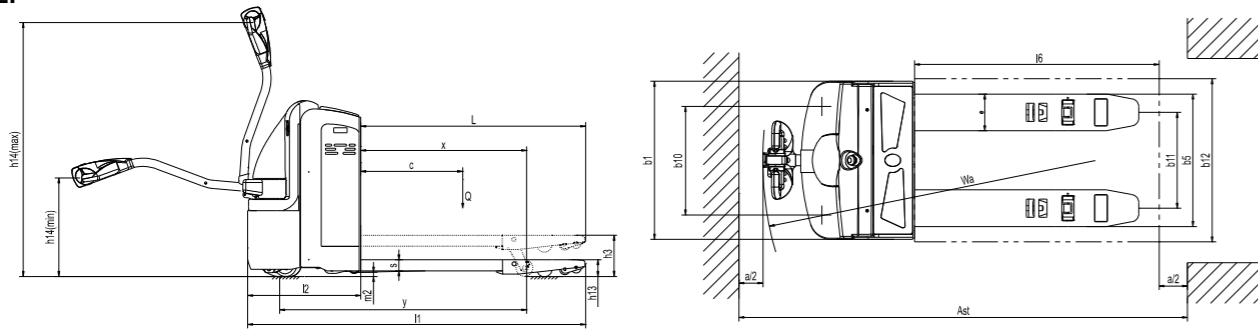

Option

15EP

- Load backrest 1220mm
- Fork length (mm)
900, 1000, 1220
- German Frei Tiller
- Single Fork Wheel (∅80x93mm)
- Overall Fork width x length : 685x1,150mm

(1,800, 2,400 : rated load capacity 1.5t)

- German Frei Tiller

20EP

- Single Fork Wheel (∅82x126mm)
- Battery (24V/210Ah)
- Battery (24V/240Ah)
- Integrated Charger (24V/20A)
- Separate Charger (24V/30A)
- Battery trolley
- Cold Storage Specifications -18°C
- Foot protection strip
- Key pad ignition
- Load backrest 1220mm
- Fork length(mm)
800, 900, 1,000, 1,220, 1,600, 1,800, 2,400mm
(1,800, 2,400 : rated load capacity 1.5t)
- German Frei Tiller
- Overall Fork width x length : 685x1,150mm

18EP

- Single Fork Wheel (∅82x98mm)
- Cold Storage Specifications -18°C
- Battery (24V/160Ah)
- Integrated Charger (24V/15A)
- Separate Charger (24V/15A)
- Battery trolley
- Foot protection strip
- Key pad ignition
- Load backrest 1220mm
- Fork length(mm)
800, 900, 1,000, 1,220, 1,600, 1,800, 2,400mm

Specifications (according to VDI 2198)

Characteristics						
1.1	Manufacturer(abbreviation)		Hyundai	Hyundai	Hyundai	
1.2	Model		15EP	18EP	20EP	
1.3	Drive type		electric	electric	electric	
1.4	Operator type		pedestrian	pedestrian	pedestrian	
1.5	Load capacity/rated load	Q	kg	1500	1800	2000
1.6	Load center distance	c	mm	600	600	600
1.8	Load distance	x	mm	886	856	865
1.9	Wheelbase	y	mm	1152	1200	1261
Weight						
2.1	Service weight(with battery)		kg	230	520	620
2.2	Axle load, front/rear, laden		kg	442/1288	720/1600	1170/1450
2.3	Axle load, front/rear, unladen		kg	200/30	420/100	470/150
Wheels/Chassis						
3.1	Tyres: solud rubber, superelastic, pneumatic, polyurethane			polyurethane	polyurethane	polyurethane
3.2	Tyre size, front			∅ 195x70	∅ 250x70	∅ 250x70
3.3	Tyre size, rear			∅ 80x 70	∅ 80x70	∅ 82x98
3.4	Additional wheels(dimensions)			∅ 60x35	∅ 114x60	∅ 127x57
3.5	Wheels number, front/rear (x = driven wheels)			1x2/4	1x+2/4	1x+2/4
3.6	Tread, front	b10	mm	195	476	510
3.7	Tread, rear	b11	mm	390	400	370
Dimension						
4.4	Lift height	h3	mm	105/115	120	120
4.9	Min. /Max. height of operation handle, in driving position	h14	mm	950/1310	780/1230	780/1230
4.15	Height, lowered	h13	mm	85/75	84	82
4.19	Overall length	l1	mm	1525	1651	1705
4.20	Length to fork face	l2	mm	373	500	555
4.21	Overall width of truck body	b1	mm	685	682	775
4.22	Fork dimension	s/e/l	mm	53/160/1150	54/150/1150	54/180/1150
4.25	Overall width of fork	b5	mm	550	550	550
4.32	Wheelbase ground distance	m2	mm	32/22	28	28
4.33	Aisle width, with pallet 1000x1200 crosswise	Ast	mm	1725	1863	2065
4.34	Aisle width, with pallet 800x1200 lengthwise	Ast	mm	1775	1913	2115
4.35	Turning radius	Wa	mm	1347	1367	1450
Performance Data						
5.1	Traveling speed, laden/unladen		km/h	5.8/6.0	5.8/6.0	5.8/6.0
5.2	Lifting speed, laden/unladen		m/s	0.035/0.045	0.06/0.11	0.039/0.056
5.3	Lowering speed, laden/unladen		m/s	0.08/0.037	0.12/0.13	0.064/0.050
5.7	Gradeability, laden/unladen		%	5/15	8/20	6/12
5.10	Traveling brake			electromagnetic brake	electromagnetic brake	electromagnetic brake
Motor						
6.1	Driving motor power		kW	0.9	1.2	1.2
6.2	Lifting motor power		kW	0.8	1.2	1.2
6.4	Battery voltage/rated capacity		V/Ah	24/80	24/160	24/210
6.5	Battery weight		kg	49	160	196

Electric Pallet truck(Rider Type)

20/25EPR



■ photo may include optional equipment.

Standard Configurations

20EPR

- Lifting Capacity : 2,000kg
- AC Drive Motor : 1.5kW
- Lift motor 1.2kW
- Curtis controller
- Drive wheel : 250x80mm
- Double Fork wheel : ϕ 82x98mm
- Hourmeter, battery discharge indicator (BDI) & lift cut off
- Overall Fork Width x Length : 550mm x 1,150mm
- Turtle mode switch
- Curtis Tiller with Convenient Control Buttons
- EPS(Electric Power Steering)
- With Platform
- Side Battery Removal

25EPR

- Lifting Capacity : 2,500kg
- AC Drive Motor : 1.5kW
- Lift motor 1.2kW
- Curtis controller
- Drive wheel : 250x80mm
- Double Fork wheel : ϕ 82x98mm
- Hourmeter, battery discharge indicator (BDI) & lift cut off
- Overall Fork Width x Length : 550mm x 1,150mm
- Turtle mode switch
- Curtis Tiller with Convenient Control Buttons
- EPS(Electric Power Steering)
- With Platform
- Side Battery Removal

Advantages

SAFETY AND PRODUCTIVITY

- Advanced AC control system eliminates directional contactors, which makes the minimal maintenance requirements.
- Intelligentized regenerative brake system: increase overall truck performance.
- Side-way battery with roll-out system.
- Belly switch.
- Emergency switch.
- Turtle mode switch
- Proportional Travel speed control.

STRUCTURAL

- The motor structure is water-proof and dust-proof(IP 44)
- Spring-loaded castors improve lateral stability on uneven floors and enhance truck performance and service life.
- Welded type fork.

SERVICEABILITY

- CANbus technology reduces wiring complexity.
- All pivot points have grease fitting and serviceable bushing, to reduce component-wearing.

Tiller Head



Curtis Tiller with convenient control buttons (standard)



Germany Frei Tiller (option)

Dimension

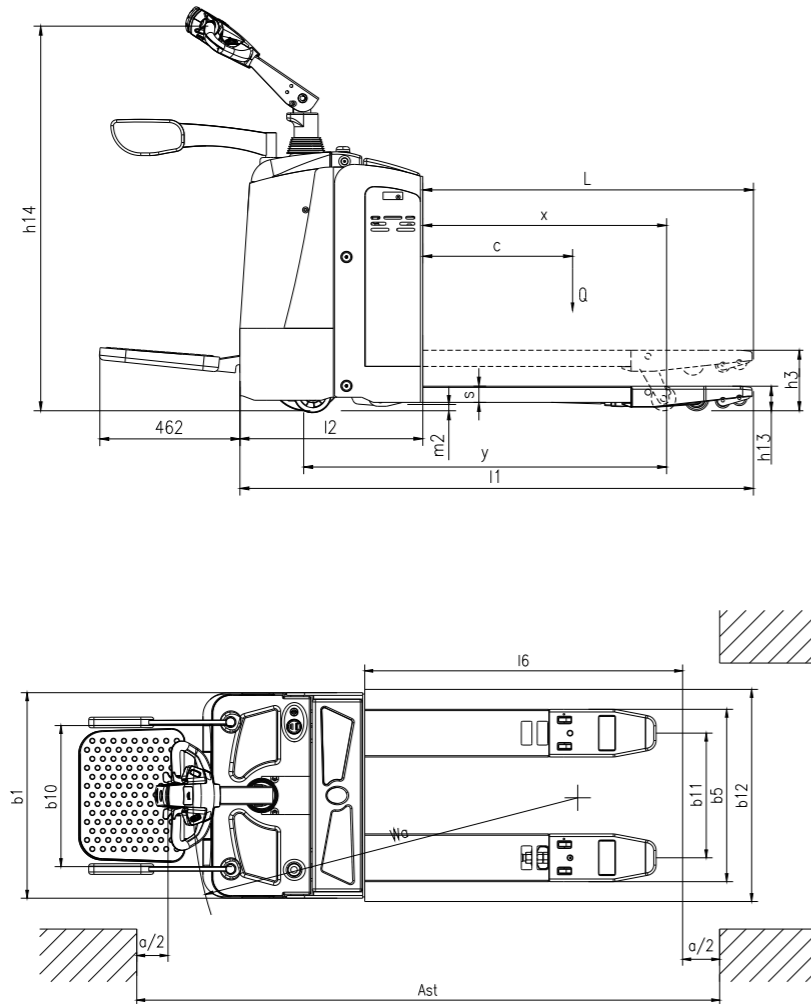

Option

- 7km/h of Drive Speed (1.2kW Drive motor)
- Single Fork Wheel : $\phi 82 \times 126\text{mm}$
- Battery (24V/210Ah - 20EPR)
- Battery (24V/240Ah - 20EPR, 25EPR)
- Battery (24V/400Ah - 20EPR, 25EPR)
- Enlarged Battery Compartment for 400Ah Battery
- Integrated charger (24V/20A)
- Separate charger (24V/30A)
- Separate charger (24V/50A for 400Ah Battery)
- Cold storage Specifications -18°C
- Key pad ignition
- German Frei Tiller
- Load backrest 1,220mm
- Without EPS
- Battery trolley
- Fork length(mm)
800, 900, 1,000, 1,220, 1,600, 1,800, 2,400
(1,800, 2,400 : rated load capacity 1.5t)
- Overall Fork width \times length : 685mm \times 1,150mm

Specifications (according to VDI 2198)

Characteristics					
1.1	Manufacturer(abbreviation)		Hyundai	Hyundai	
1.2	Model		20EPR	25EPR	
1.3	Drive type		Electric	Electric	
1.4	Operator type		standing	standing	
1.5	Load capacity/rated load	Q	kg	2000	2500
1.6	Load center distance	c	mm	600	600
1.8	Load distance	x	mm	865	865
1.9	Wheelbase	y	mm	1261	1261
Weight					
2.1	Service weight(with battery)		kg	710	750
2.2	Axle load, front/rear, laden		kg	1300/1410	1300/1410
2.3	Axle load, front/rear, unladen		kg	600/110	600/110
Wheels/Chassis					
3.1	Tyres: solid rubber, superelastic, pneumatic, polyurethane			polyurethane	polyurethane
3.2	Tyre size, front			$\phi 250 \times 80$	$\phi 250 \times 80$
3.3	Tyre size, rear			$\phi 82 \times 98$	$\phi 82 \times 98$
3.4	Additional wheels(dimensions)			$\phi 127 \times 57$	$\phi 127 \times 57$
3.5	Wheels number, front/rear (x = driven wheels)			1X+2/4	1X+2/4
3.6	Tread, front	b10	mm	490	490
3.7	Tread, rear	b11	mm	370	370
Dimension					
4.4	Lift height	h3	mm	120	120
4.9	Min. /Max. height of operation handle, in driving position	h14	mm	1150/1430	1150/1430
4.15	Height, lowered	h13	mm	82	82
4.19	Overall length	l1	mm	1760	1760
4.20	Length to fork face	l2	mm	610	610
4.21	Overall width of truck body	b1	mm	775	775
4.22	Fork dimension	s/e/l	mm	1150	1150
4.25	Overall width of fork	b5	mm	550	550
4.32	Wheelbase ground distance	m2	mm	28	28
4.33	Aisle width, with pallet 1000x1200 crosswise	Ast	mm	1960	1960
4.34	Aisle width, with pallet 800x1200 lengthwise	Ast	mm	2120	2120
4.35	Turning radius	Wa	mm	1600	1600
Performance Data					
5.1	Traveling speed, laden/unladen		km/h	6.1/9.0	6.1/9.0
5.2	Lifting speed, laden/unladen		m/s	0.039/0.056	0.039/0.056
5.3	Lowering speed, laden/unladen		m/s	0.064/0.05	0.064/0.05
5.7	Gradeability, laden/unladen		%	6/12	6/12
5.8	Max. gradeability, laden/unladen		%	8/20	6/20
5.10	Traveling brake			electromagnetic brake	electromagnetic brake
Motor					
6.1	Driving motor power		kW	1.5	1.5
6.2	Lifting motor power		kW	1.2	1.2
6.4	Battery voltage/rated capacity		kg	24/210	24/240
6.5	Battery weight		kg	210	240

Electric Pallet Truck with Double Pallet(Rider Type)

20EDPR



■ photo may include optional equipment.

Standard Configurations

20EDPR

- Lifting Capacity : 2,000kg
- AC Drive Motor 1.5kW
- Lift motor 2.2kW
- Curtis controller
- Drive wheel : Φ 250x80mm
- Double Fork wheel : Φ 80x70mm
- Triplex 2.5 m MFH Mast

- Turtle mode switch
- With Platform
- Hourmeter, battery discharge indicator (BDI) with lift cut off
- Overall Fork Width x Length : 570 x 1,150mm
- German Frei tiller
- Side Battery Removal
- EPS (Electric Power Steering)
- German Frei tiller with Convenient control Buttons
- Initial Lift (120mm)

Advantages

SAFETY AND PRODUCTIVITY

- Advanced AC control system eliminates directional contactors, which makes the minimal maintenance requirements.
- Intelligent regenerative brake system.
- Platform with sensor + suspension system.
- Emergency switch.
- Belly Switch.
- Multi function display with BDI(battery discharge indicator) and working hours.
- 20% max gradeability.
- Electric Power Steering system (EPS), makes truck steering very smoothly and light .

STRUCTURAL

- Hard steel rear cover, anti-collision, easy disassembly, provides convenient access to all component.
- Only 90mm lowered fork height.
- The motor structure is water-proof and dust-proof(IP 44).
- Side-way battery with roll-out system.

SERVICEABILITY

- Easy replacement and maintenance for the traction wheel.

Tiller Head

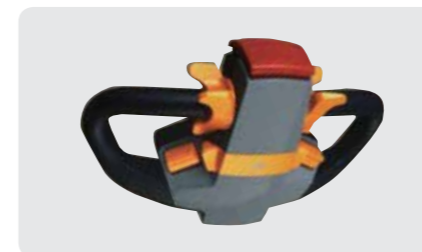

Germany Frei Tiller (Standard)
with convenient control buttons



Germany Frei Tiller (Option)

Dimension

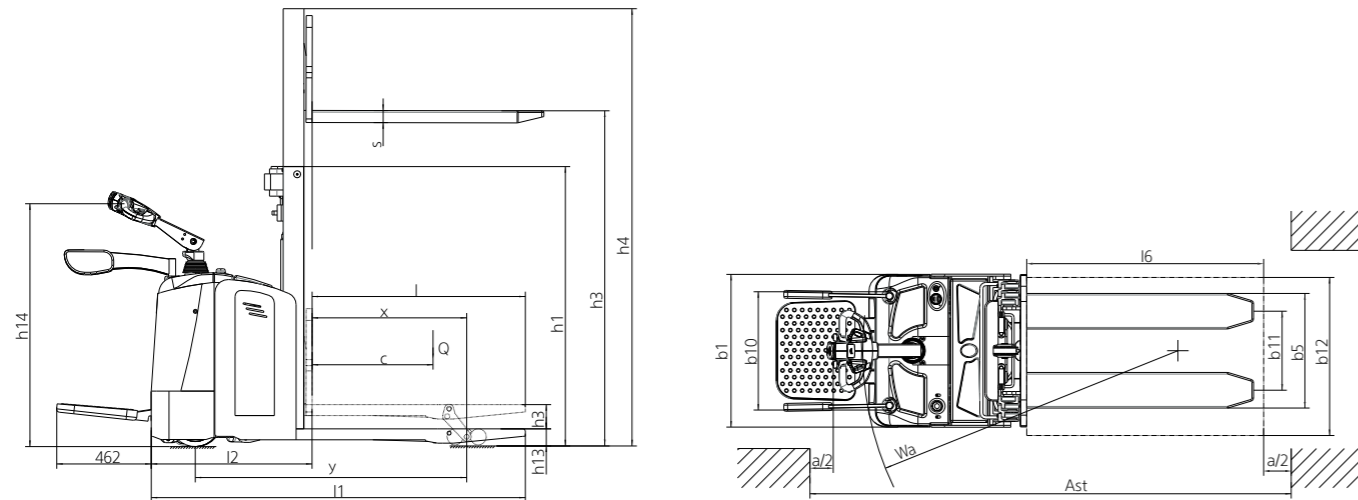

Option

- Battery (24V/240Ah)
- Separate Charger (24V/30A)
- Cold storage Specifications -18°C
- Key pad ignition
- Battery trolley
- Fork length(mm)
800, 900, 1,000, 1,220
- Mast : Triplex 1.6m, 2.0m MFH
- German Frei tiller (Normal)

Mast Specifications

Mast Ref.	Lift Height		Overall Height		Service Weight (kg)	Residual Capacity (kg)
	Max. (mm) h3	Free lift (mm) -	Lowered (mm) h1	Extended (mm) h4		
Triplex mast with free lift (1.6m MFH)	1.6	N/A	1082	2118	1130	2000
Triplex mast with free lift (2.0m MFH)	2	N/A	1212	2508	1130	2000
Triplex mast with free lift (2.5m MFH)	2.5	N/A	1382	3018	1130	2000

Lifting Capacity

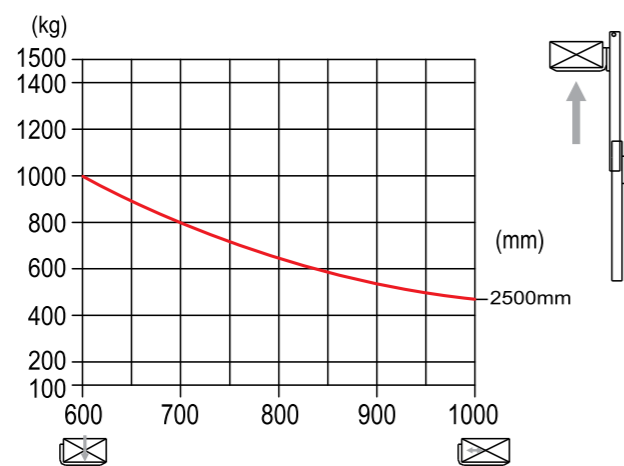

Specifications (according to VDI 2198)

Characteristics			
1.1	Manufacturer(abbreviation)		Hyundai
1.2	Model		20EDPR
1.3	Drive type		electric
1.4	Operator type		standing
1.5	Load capacity/rated load	Q	kg 2000
1.6	Load center distance	c	mm 600
1.8	Load distance	x	mm 767
1.9	Wheelbase	y	mm 1348
Weight			
2.1	Service weight(with battery)		See mast Specifications
2.2	Axle load, front/rear, laden		1090/2040
2.3	Axle load, front/rear, unladen		840/290
Wheels/Chassis			
3.1	Tyres: solid rubber, superelastic, pneumatic, polyurethane		polyurethane
3.2	Tyre size, front		Φ 250×80
3.3	Tyre size, rear		Φ 80×70
3.4	Additional wheel(dimension)		Φ 127×57
3.5	Wheels number, front/rear (x = driven wheels)		1X+2/4
3.6	Tread, front	b10	mm 490
3.7	Tread, rear	b11	mm 390
Dimension			
4.2	Height of mast, lowered	h1	mm See mast Specifications
4.4	Lift height	h3	mm See mast Specifications
4.5	Max. height of mast, extended	h4	mm See mast Specifications
4.7	Lifting height for leg	h5	mm 120
4.9	Min. /Max. height of operation handle, in driving position	h14	mm 1150/1430
4.15	Height, lowered	h13	mm 90
4.19	Overall length	l1	mm 1948
4.20	Length to fork face	l2	mm 798
4.21	Overall width of truck body	b1	mm 775
4.22	Fork dimension	s/e/l	mm 54×180×1150
4.25	Overall width of fork	b5	mm 570
4.32	Wheelbase ground distance	m2	mm 28
4.33	Aisle width, with pallet 1000x1200 crosswise	Ast	mm 2148
4.34	Aisle width, with pallet 800x1200 lengthwise	Ast	mm 2198
4.35	Turning radius	Wa	mm 1600
Performance Data			
5.1	Traveling speed, laden/unladen	km/h	7.8/9.0
5.2	Lifting speed, laden/unladen	m/s	0.11/0.19
5.3	Lowering speed, laden/unladen	m/s	0.16/0.11
5.7	Gradeability, laden/unladen	%	8/20
5.8	Max. gradeability, laden/unladen	%	8/20
5.10	Traveling brake		electromagnetic braking
Motor			
6.1	Driving motor power	kW	1.5
6.2	Lifting motor power	kW	2.2
6.4	Battery voltage/rated capacity	V/Ah	24/240
6.5	Battery weight	Kg	235

Electric Stacker

10/12/15ES



■ photo may include optional equipment.

Standard Configurations

10ES

- Lifting Capacity : 1,000kg
- AC Drive Motor 1.2kW / Lift motor 2.2kW
- Curtis controller
- Drive wheel : ϕ 250x70mm
- Double Fork wheel : ϕ 80x70mm
- Hourmeter, battery discharge indicator(BDI) & lift cut off
- Duplex 3.0m MFH Mast without free lift
- Overall Fork Width x Length : 570mm x 1,150mm
- Turtle mode switch
- Curtis Tiller with Convenient Control Buttons
- Side Battery Removal

12ES

- Lifting Capacity : 1,200kg
- AC Drive Motor 1.2kW / Lift motor 2.2kW
- Curtis controller
- Drive wheel : ϕ 250x70mm
- Double Fork wheel : ϕ 80x70mm
- Hourmeter, battery discharge indicator(BDI) & lift cut off
- Duplex 3.0m MFH Mast without free lift
- Overall Fork Width x Length : 570mm x 1,150mm
- Turtle mode switch
- Curtis Tiller with Convenient Control Buttons
- Side Battery Removal

15ES

- Lifting Capacity : 1,500kg
- AC Drive Motor 1.5kW / Lift motor 3.2kW
- Curtis controller
- Drive wheel : ϕ 250x70mm
- Double Fork wheel : ϕ 84x80mm
- Hourmeter, battery discharge indicator(BDI) & lift cut off
- Duplex 3.0m MFH Mast with free lift
- Overall Fork Width x Length : 570mm x 1,150mm
- Turtle mode switch
- German Frei Tiller with Convenient Control Buttons
- Proportional Lifting
- Automatic Drive speed reduction (lifting over 1.8m)
- Side Battery Removal

Advantages

SAFETY AND PRODUCTIVITY

- Advanced AC control system eliminates directional contactors, which brings minimal maintenance requirements.
- Intelligent regenerative brake system.
- Multi-function display with BDI and hour meter etc.
- Belly switch.
- Emergency switch.
- Proportional Travel speed control.
- Lift limit switch to shut off pump motor at the max. lifting height.
- Vertical drive motor has a small turning radius.
- The motor structure is water-proof and dust-proof(IP 44).

SERVICEABILITY

- CANbus technology reduces wiring complexity and increases reliability.
- Side-way battery with roll-out system.

Tiller Head



Curtis Tiller with convenient control buttons
(Standard for 10/12ES only)

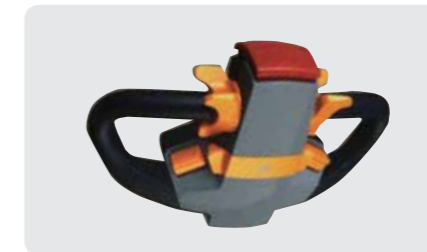

Germany Frei Tiller
with convenient control buttons
(Standard for 15ES only)



Normal Germany Frei Tiller (option)

Dimension

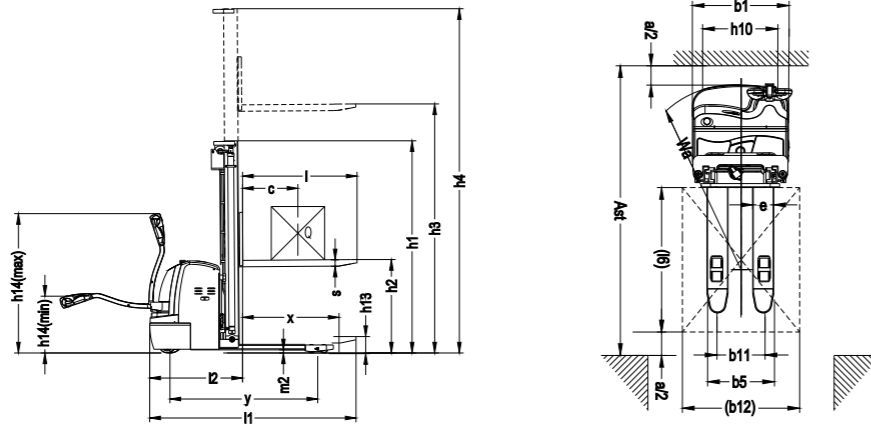

Lifting capacity

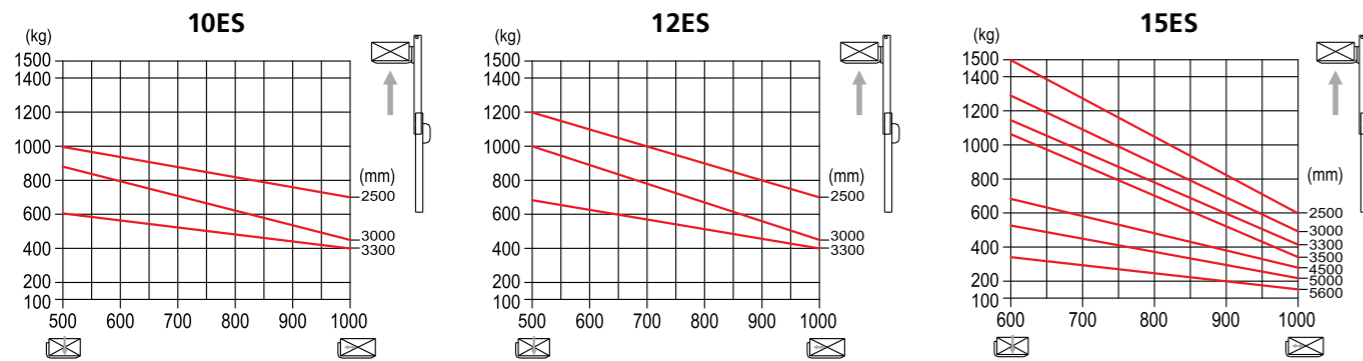

Option

- **Battery**
10/12 ES : (24V/120Ah)
15 ES : (24V/300Ah)
- **Integrated Charger (Built-In)**
10/12 ES : (24V/15A)
15 ES : (24V/40A)
- **Separate Charger**
10/12 ES : (24V/15A)
15 ES : (24V/40A)
- **Key pad ignition**
- **Battery trolley**
- **Fork length(mm)**
10/12/15 ES : 800, 900, 1,000, 1,200
- **Germal Feri Tiller (Nomal)**
- **Germal Feri Tiller with big button (including initial lifting button) (15ES)**
- **Cold Storage Specifications -18°C**
- **Initial Lift (15ES)**

Mast Specifications

Mast Ref.	Lift Height		Overall Height		Service Weight (kg)	Residual Capacity (kg)	
	Max. (mm) h3	Free lift (mm) -	Lowered (mm) h1	Extended (mm) h4			
10ES	Duplex 2.5m MFH Mast without free lift	2.5	N/A	1837	3087	730	1000
	Duplex 3.0m MFH Mast without free lift *	3.0	N/A	2087	3587	750	750
	Duplex 3.3m MFH Mast without free lift	3.3	N/A	2237	3887	770	550
12ES	Duplex 2.5m MFH Mast without free lift	2.5	N/A	1837	3087	750	1200
	Duplex 3.0m MFH Mast without free lift *	3.0	N/A	2087	3587	770	1000
	Duplex 3.3m MFH Mast without free lift	3.3	N/A	2237	3887	790	700
15ES	Duplex mast without free lift (2.5m MFH)	2.5	N/A	1735	2955	1040	1500
	Duplex mast without free lift (3.0m MFH)	3.0	N/A	1985	3455	1160	1300
	Duplex mast without free lift (3.3m MFH)	3.3	N/A	2135	3755	1180	1150
	Duplex mast without free lift (3.5m MFH)	3.5	N/A	2235	3955	1200	1100
	Duplex mast with free lift (2.5m MFH)	2.5	1300	1735	2955	1080	1500
	Duplex mast with free lift (3.0m MFH) *	3.0	1550	1985	3455	1200	1300
	Duplex mast with free lift (3.3m MFH)	3.3	1700	2135	3755	1220	1150
	Duplex mast with free lift (3.5m MFH)	3.5	1800	2235	3955	1240	1100
	Triflex mast with free lift (4.5m MFH)	4.5	1570	2050	5070	1405	700
	Triflex mast with free lift (5.0m MFH)	5.0	1740	2210	5550	1450	500
Triflex mast with free lift (5.6m MFH)	5.6	1940	2410	6150	1490	350	

* : Standard

Specifications (according to VDI 2198)

Characteristics			
1.1	Manufacturer(abbreviation)		Hyundai
1.2	Model		10ES 12ES 15ES
1.3	Drive type		electric
1.4	Operator type		pedestrian
1.5	Load capacity/rated load	Q kg	1000 1200 1500
1.6	Load center distance	c mm	500 500 600
1.8	Load distance	x mm	697 697 697
1.9	Wheelbase	y mm	1335 1335 1383
Weight			
2.1	Service weight(with battery)	kg	See mast Specifications
2.2	Axle load, front/rear, laden	kg	950/770 1060/870 1470/1310
2.3	Axle load, front/rear, unladen	kg	555/165 560/170 900/380
Wheels/Chassis			
3.1	Tyres: solid rubber, superelastic, pneumatic, polyurethane		polyurethane
3.2	Tyre size, front		Φ250×70 Φ250×70 Φ250×70
3.3	Tyre size, rear		Φ80×70 Φ80×70 Φ80×84
3.4	Additional wheel(dimension)		Φ150×60 Φ150×60 Φ150×60
3.5	Wheels number, front/rear (x = driven wheels)		1x+1/4 1x+1/4 1x+1/4
3.6	Tread, front	b10 mm	520 520 520
3.7	Tread, rear	b11 mm	400 400 390
Dimension			
4.2	Height of mast, lowered	h1 mm	See mast Specifications
4.3	Free lift height(optional)		See mast Specifications
4.4	Lift height	h3 mm	See mast Specifications
4.5	Max. height of mast, extended	h4 mm	See mast Specifications
4.9	Min./Max. height of operation handle, in driving position	h14 mm	670/1300 670/1300 670/1300
4.15	Height, lowered	h13 mm	90 90 90
4.19	Overall length	l1 mm	1942 1942 2028
4.20	Length to fork face	l2 mm	792 792 878
4.21	Overall width of truck body	b1 mm	820 820 820
4.22	Fork dimension	s/e/l mm	60/170(1150) 60/170(1150) 60/180(1150)
4.25	Overall width of fork	b5 mm	570 570 570
4.32	Wheelbase ground distance	m2 mm	28 28 31
4.33	Aisle width, with pallet 1000x1200 crosswise	Ast mm	2400 2400 2450
4.34	Aisle width, with pallet 800x1200 lengthwise	Ast mm	2370 2370 2420
4.35	Turning radius	Wa mm	1525 1525 1575
Performance Data			
5.1	Traveling speed, laden/unladen	km/h	5.8/6.0 5.8/6.0 5.8/6.0
5.2	Lifting speed, laden/unladen	m/s	0.11/0.19 0.11/0.19 0.15/0.28
5.3	Lowering speed, laden/unladen	m/s	0.16/0.11 0.16/0.11 0.41/0.27
5.8	Max. gradeability, laden/unladen	%	6/15 6/15 8/15
5.10	Traveling brake		electromagnetic brake
Motor			
6.1	Driving motor power	kW	1.2 1.2 1.5
6.2	Lifting motor power	kW	2.2 2.2 3.2
6.4	Battery voltage/rated capacity	V/Ah	24/120 24/120 24/300
6.5	Battery weight	kg	90 90 260



■ photo may include optional equipment.

Standard Configurations

12ESN

- Lifting Capacity : 1,200kg
- AC Drive Motor 1.2kW
- Lift motor : 2.2kW
- Curtis controller
- Drive wheel : ϕ 250x70mm
- Double Fork wheel : ϕ 80x70mm
- Hourmeter, battery discharge indicator (BDI) & lift cut off
- Single 1.95m MFH Mast
- Lowered Height : 2.33m
- Overall Fork Width x Length : 570mm x 1,150mm
- Turtle mode switch
- Curtis Tiller with Convenient Control Buttons
- Automatic drive speed reduction (lifting over 1.8m)
- Built-in Battery (24V/80Ah), Charger (24V/8A)
- Belly Switch
- Side Battery Removal

Advantages

SAFETY AND PRODUCTIVITY

- Advanced AC control system
- Intelligentized regenerative brake system.
- Multi-function display with BDI and hour meter etc.
- Belly switch.
- Emergency switch.
- Proportional Travel speed control.
- Lift limit switch to shut off pump motor at the max. lifting height.
- Vertical drive motor has a small turning radius.
- The motor structure is water-proof and dust-proof(IP 44).

SERVICEABILITY

- CANbus technology reduces wiring complexity and increase reliability.
- Side-way battery with roll-out system.

Tiller Head



Curtis Tiller with convenient control buttons (standard)



Germany Frei Tiller (option)

Dimension

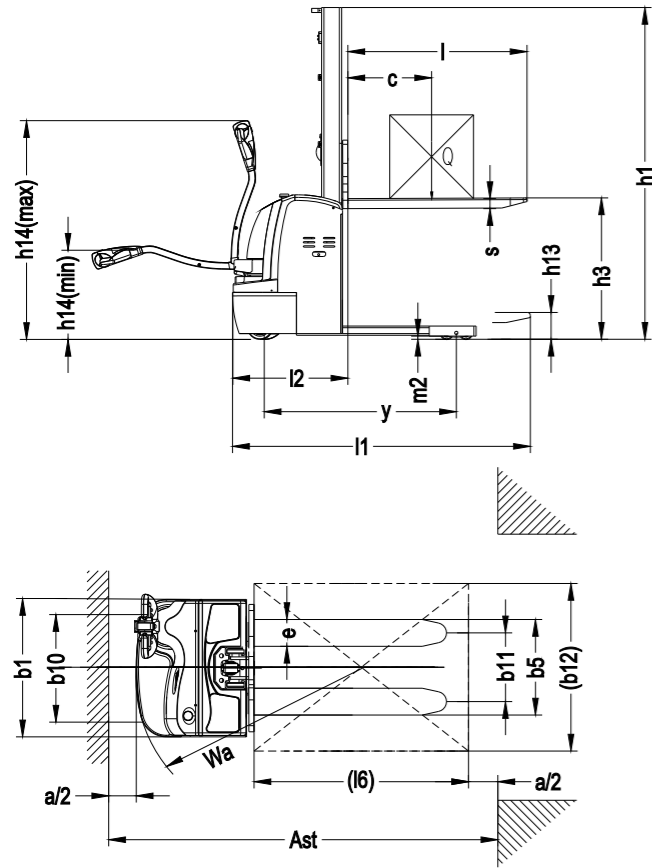

Lifting capacity

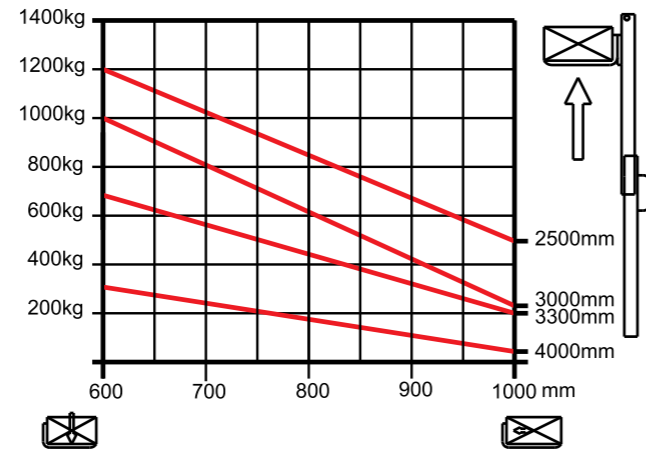

Option

- Single 1.6m MFH Mast
- Fork length(mm)
800, 900, 1,000, 1,200
- German Frei Tiller
- Cold Storage Specifications -18°C

Mast Specifications

Mast Ref.	Lift Height		Overall Height		Service Weight (kg)	Residual Capacity (kg)
	Max. (mm) h3	Free lift (mm) -	Lowered (mm) h1	Extended (mm) h4		
Single 1.6m MFH Mast	1.6	1.6	1980	2330	590	1200
Single 1.95m MFH Mast *	1.9	1.9	1980	2330	590	1200

* : Standard

Specifications (according to VDI 2198)

Characteristics			
1.1	Manufacturer(abbreviation)		Hyundai
1.2	Model		12ESN
1.3	Drive type		electric
1.4	Operator type		walking
1.5	Load capacity/rated load	Q	kg
1.6	Load center distance	c	mm
1.8	Load distance	x	mm
1.9	Wheelbase	y	mm
Weight			
2.1	Service weight(with battery)	kg	See mast Specifications
2.2	Axle load, front/rear, laden	kg	790/1000
2.3	Axle load, front/rear, unladen	kg	195/395
Wheels/Chassis			
3.1	Tyres: solid rubber, superelastic, pneumatic, polyurethane		polyurethane
3.2	Tyre size, front		φ 250×70
3.3	Tyre size, rear		φ 80×70
3.4	Additional wheel(dimension)		φ 150×60
3.5	Wheels number, front/rear (x = driven wheels)		1x+1/4
3.6	Tread, front	b10	mm
3.7	Tread, rear	b11	mm
Dimension			
4.2	Height of mast, lowered	h1	mm
4.4	Lift height	h3	mm
4.5	Max. height of mast, extended	h4	mm
4.9	Min. /Max. height of operation handle, in driving position	h14	mm
4.15	Height, lowered	h13	mm
4.19	Overall length	l1	mm
4.20	Length to fork face	l2	mm
4.21	Overall width of truck body	b1	mm
4.22	Fork dimension	s/e/l	mm
4.25	Overall width of fork	b5	mm
4.32	Wheelbase ground distance	m2	mm
4.33	Aisle width, with pallet 1000x1200 crosswise	Ast	mm
4.34	Aisle width, with pallet 800x1200 lengthwise	Ast	mm
4.35	Turning radius	Wa	mm
Performance Data			
5.1	Traveling speed, laden/unladen	km/h	5.8/6.0
5.2	Lifting speed, laden/unladen	m/s	0.11/0.19
5.3	Lowering speed, laden/unladen	m/s	0.16/0.11
5.8	Max. gradeability, laden/unladen	%	6/15
5.10	Traveling brake		electromagnetic brake
Motor			
6.1	Driving motor power	kW	1.2
6.2	Lifting motor power	kW	2.2
6.4	Battery voltage/rated capacity	V/Ah	24/80
6.5	Battery weight	kg	50

Electric Stacker(Rider Type)

15ESR



■ photo may include optional equipment.

Standard Configurations

15ESR

- Lifting Capacity : 1,500kg
- AC Drive Motor 1.5kW
- Lift motor 3.2kW
- Curtis controller
- Drive wheel : ϕ 250x80mm
- Double Fork wheel : ϕ 84x80mm
- Hourmeter, battery discharge indicator (BDI) & Limiter with lift cut off
- Duplex 3.0m MFH Mast with free lift

- Fork Width x Length : 570mm x 1,150mm
- Turtle mode switch
- German Frei tiller with convenient control buttons
- Proportional Lifting
- Automatic speed reduction (lifting over 1.8m)
- Belly switch
- EPS (Electric Power Steering)
- Side Battery Removal

Advantages

SAFETY AND PRODUCTIVITY

- Advanced AC control system eliminates directional contactors, which brings minimal maintenance requirements.
- Mast lowering damping cushion for low noise operation.
- Multi-function display with BDI and hour meter etc.
- Side way battery replacement.
- Auto deceleration function.
- Emergency switch.
- Turtle mode switch.
- Proportional Travel speed control.

OPTIMUM STRUCTURAL DESIGN

- Low barycenter ensures the stable operation.
- The motor structure is water-proof and dust-proof(IP 44).
- Mast and frame dividable and exchangeable.
- Full free lifting. (3M lift height truck can enter into a 2M door)

SERVICEABILITY

- Central positional electronic component simplifies debugging and maintaining.
- CANbus technology reduces wiring complexity and increase reliability.
- User of non-contact type switch in the mast

Tiller Head



Germany Frei Tiller with convenient control buttons (standard)



Germany Frei Tiller (option)

Dimension

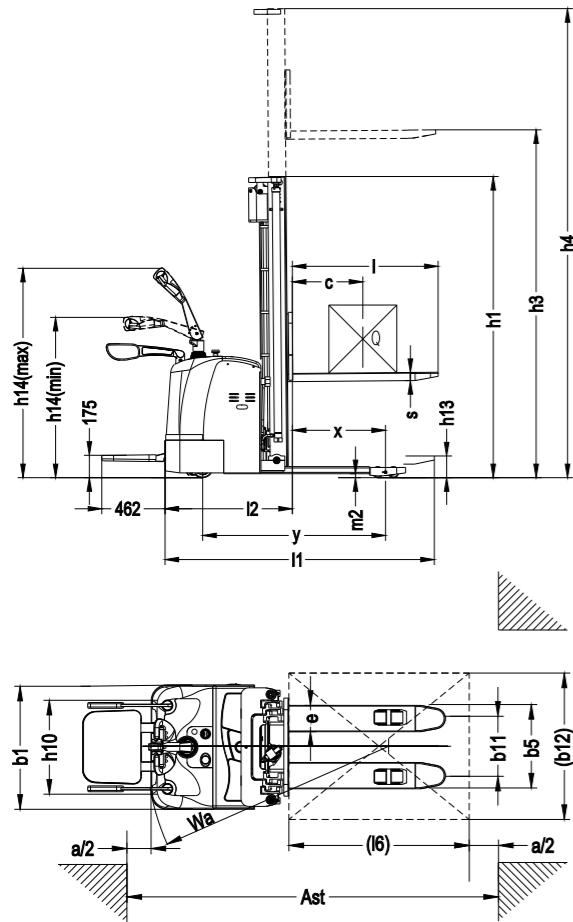

Option

- 6.7km/h of Drive Speed
- Battery : 24V/300Ah
- Integrated Charger (24V/40A)
- Separate Charger (24V/40A)
- Germany Frei Tiller (Normal)
- Germal Feri Tiller with big button (including initial lifting button)
- Cold storage Specifications -18°C
- Key pad ignition
- Load backrest 1220mm
- Battery trolley
- Initial lift
- Fork length(mm) 800, 900, 1,000, 1,200
- Without EPS

Lifting capacity

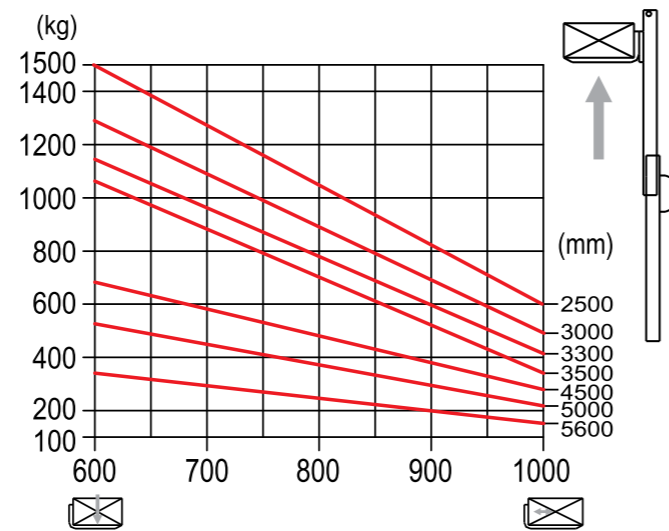

Mast Specifications

Mast Ref.	Lift Height		Overall Height		Service Weight (kg)	Residual Capacity (kg)
	Max. (mm) h3	Free lift (mm) -	Lowered (mm) h1	Extended (mm) h4		
Duplex mast without free lift (2.5m MFH)	2.5	N/A	1735	2955	1200	1500
Duplex mast without free lift (3.0m MFH)	3.0	N/A	1985	3455	1220	1300
Duplex mast without free lift (3.3m MFH)	3.3	N/A	2135	3755	1240	1150
Duplex mast without free lift (3.5m MFH)	3.5	N/A	2235	3955	1250	1100
Duplex mast with free lift (2.5m MFH)	2.5	1300	1735	2955	1240	1500
Duplex mast with free lift (3.0m MFH) *	3.0	1550	1985	3455	1265	1300
Duplex mast with free lift (3.3m MFH)	3.3	1700	2135	3755	1280	1150
Duplex mast with free lift (3.5m MFH)	3.5	1800	2235	3955	1290	1100
Triflex mast with free lift (4.5m MFH)	4.5	1570	2050	5070	1340	700
Triflex mast with free lift (5.0m MFH)	5.0	1740	2210	5550	1360	500
Triflex mast with free lift (5.6m MFH)	5.6	1940	2410	6150	1380	350

* : Standard

Specifications (according to VDI 2198)

Characteristics			
1.1	Manufacturer(abbreviation)		Hyundai
1.2	Model		15ESR
1.3	Drive type		electric
1.4	Operator type		standing
1.5	Load capacity/rated load	Q	kg 1500
1.6	Load center distance	c	mm 600
1.8	Load distance	x	mm 672
1.9	Wheelbase	y	mm 1378
Weight			
2.1	Service weight(with battery)	kg	See mast Specifications
2.2	Axle load, front/rear, laden	kg	1470/1310
2.3	Axle load, front/rear, unladen	kg	900/380
Wheels/Chassis			
3.1	Tyres: solid rubber, superelastic, pneumatic, polyurethane		polyurethane
3.2	Tyre size, front		φ 250×80
3.3	Tyre size, rear		φ 80×84
3.4	Additional wheel(dimension)		φ 150×60
3.5	Wheels number, front/rear (x = driven wheels)		1x+2/4
3.6	Tread, front	b10	mm 580
3.7	Tread, rear	b11	mm 390
Dimension			
4.2	Height of mast, lowered	h1	mm See mast Specifications
4.3	Free lift height(optional)		See mast Specifications
4.4	Lift height	h3	mm See mast Specifications
4.5	Max. height of mast, extended	h4	mm See mast Specifications
4.9	Min. /Max. height of operation handle, in driving position	h14	mm 1150/1450
4.15	Height, lowered	h13	mm 90
4.19	Overall length	l1	mm 2100
4.20	Length to fork face	l2	mm 950
4.21	Overall width of truck body	b1	mm 850
4.22	Fork dimension	s/e/l	mm 60/180/1150
4.25	Overall width of fork	b5	mm 570
4.32	Wheelbase ground distance	m2	mm 31
4.33	Aisle width, with pallet 1000x1200 crosswise	Ast	mm 2535
4.34	Aisle width, with pallet 800x1200 lengthwise	Ast	mm 2515
4.35	Turning radius	Wa	mm 1655
Performance Data			
5.1	Traveling speed, laden/unladen	km/h	7.8/8.5
5.2	Lifting speed, laden/unladen	m/s	0.15/0.28
5.3	Lowering speed, laden/unladen	m/s	0.41/0.27
5.8	Max. gradeability, laden/unladen	%	8/15
5.10	Traveling brake		electromagnetic brake
Motor			
6.1	Driving motor power	kW	1.5
6.2	Lifting motor power	kW	3.2
6.4	Battery voltage/rated capacity	V/Ah	24/300
6.5	Battery weight	kg	260

Manual Hand Pallet Truck

20HP/25HP/25HPW/30HP

Standard Configurations

- Polyurethane drive steering wheel
- Double Polyurethane Fork wheels
- Overall Fork Width x Length : 550mm x 1,150mm
- Weighing Scale (25HPW)
- Rubber Wrapped handgrip (25HP/25HPW)

Option

- Nylon drive wheel and double nylon fork wheel
- Rubber drive wheel and double Polyurethane Fork wheel
- Polyurethane drive wheel and single Polyurethane Fork wheel (20HP/25HP/25HPW)
- Nylon drive wheel and single nylon Fork wheel (20HP/25HP/25HPW)
- Extra long foot pedal release (25HP/25HPW/30HP)
- Quick lift (5 strokes to reach max.height) (25HP/25HPW)
- Fork length (mm) 800, 900, 1000, 1100
- Overall Fork width x Length : 685mm x 1,220mm



■ photo may include optional equipment.

Dimension & Specifications (according to VDI 2198)

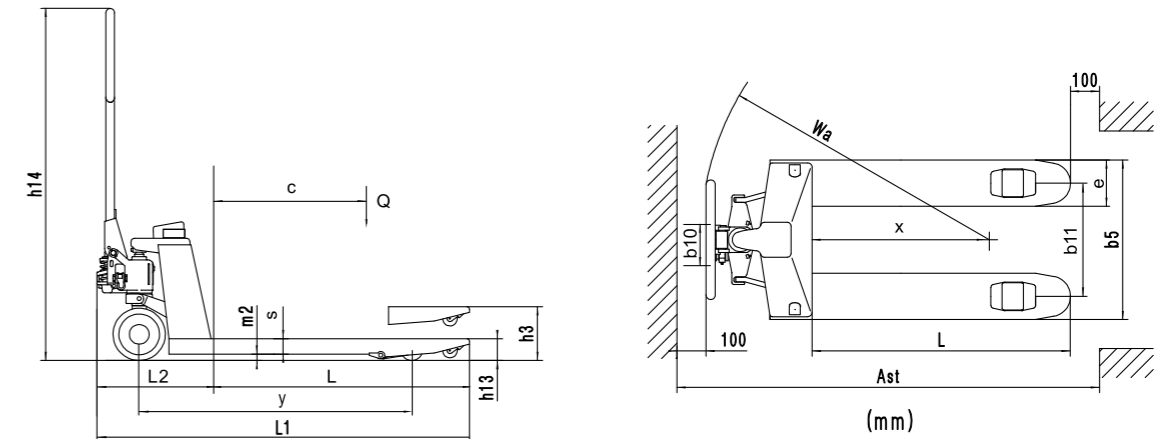

Characteristics			Hyundai	Hyundai	Hyundai	Hyundai
1.1	Manufacturer(abbreviation)		Hyundai	Hyundai	Hyundai	Hyundai
1.2	Model		20HP	25HP	30HP	25HPW
1.3	Drive type		manual	manual	manual	manual
1.4	Operator type		hand	hand	hand	hand
1.5	Load capacity/rated load	kg	2000	2500	3000	2500
1.6	Load center distance	c mm	22	32	40	40
1.8	Load distance	x mm	600	600	600	600
1.9	Wheelbase	y mm	1136	1153	1124	1124
Weight						
2.1	Service weight	kg	55	58	63	60
Wheels/Chassis						
3.1	Tyres: solid rubber, superelastic, pneumatic, polyurethane		polyurethane	polyurethane	polyurethane	polyurethane
3.2	Tyre size, front(Steering wheel)	mm	Φ 160	Φ 200	Φ 200	Φ 200
3.3	Tyre size, rear(Fork wheel single)	mm	Φ 70x80	Φ 80x93	-	Φ 80x93
	Tyre size, rear(Fork wheel tandem)	mm	Φ 70x60	Φ 80x70	Φ 80x70	Φ 80x70
3.5	Wheels number, front/rear (x = driven wheels)		2x+2/4	2x+2/4	2x+2/4	2x+2/4
3.6	Tread, front	b10 mm	108	111	120	120
3.7	Tread, rear	b11 mm	400/535	390/525	390/525	390/525
Dimension						
4.4	Max. Lift height	h3 mm	190	195	200	200
4.9	Min. /Max. height of operation handle, in driving position	h14 mm	1176.5	1224	1224	1224
4.15	Height, lowered	h13 mm	75	85	85	85
4.19	Overall length	l1 mm	1520	1543	1533	1533
4.20	Length to fork face	l2 mm	370	393.5	384	384
4.22	Fork dimension	s/e/l mm	53/150/1150	53/160/1150	45/160/1150	45/160/1150
4.25	Overall width of fork	b5 mm	550/685	550/685	550/685	550/685
4.32	Wheelbase ground distance	m2 mm	22	32	32	32
4.33	Aisle width, with pallet 1000x1200 crosswise	Ast mm	1720	1743	1733	1733
4.34	Aisle width, with pallet 800x1200 lengthwise	Ast mm	1770	1793	1783	1783
4.35	Turning radius	Wa mm	1265	1276	1266	1266